

GROUP 90

CIRCUIT DIAGRAMS

CONTENTS

HOW TO READ CIRCUIT DIAGRAMS	90-4	DOME LIGHT AND LUGGAGE COMPARTMENT LIGHT	90-66
JUNCTION BLOCK	90-10	TURN-SIGNAL LIGHT AND HAZARD WARNING LIGHT	90-70
JOINT CONNECTOR	90-12	STOPLIGHT	90-74
CENTRALIZED JUNCTION	90-18	BACKUP LIGHT	90-75
POWER DISTRIBUTION SYSTEM ..	90-24	HORN	90-76
STARTING SYSTEM <M/T>	90-30	METER AND GAUGE	90-78
STARTING SYSTEM <A/T>	90-31	BRAKE WARNING LIGHT, OIL PRESSURE WARNING LIGHT, FUEL WARNING LIGHT	90-82
IGNITION SYSTEM <M/T>	90-32	POWER WINDOWS	90-84
IGNITION SYSTEM <A/T>	90-33	CENTRAL DOOR LOCKING SYSTEM <VEHICLES WITHOUT KEYLESS ENTRY SYSTEM>	90-88
CHARGING SYSTEM <M/T>	90-34	CENTRAL DOOR LOCKING SYSTEM <VEHICLES WITH KEYLESS ENTRY SYSTEM>	90-92
CHARGING SYSTEM <A/T>	90-35	AIR CONDITIONING SYSTEM	90-100
MFI SYSTEM <M/T>	90-36	WINDSHIELD WIPER AND WASHER	90-104
MFI SYSTEM <A/T>	90-44	REAR WIPER AND WASHER	90-108
COOLING SYSTEM	90-51	REAR WINDOW DEFOGGER	90-111
INVECS-II 4A/T	90-52		
HEADLIGHT	90-58		
TAILLIGHT, POSITION LIGHT AND LICENSE PLATE LIGHT	90-62		

Continued on next page

REMOTE CONTROLLED MIRROR	90-112	ANTI-LOCK BRAKING SYSTEM (ABS)	
AUDIO SYSTEM	90-114	90-128
CLOCK	90-118	SUPPLEMENTAL RESTRAINT SYSTEM (SRS)	
CIGARETTE LIGHTER	90-119	<VEHICLES WITHOUT SIDE AIR BAG>	
AUTO-CRUISE CONTROL SYSTEM <M/T>		90-132
.....	90-120	SUPPLEMENTAL RESTRAINT SYSTEM (SRS)	
AUTO-CRUISE CONTROL SYSTEM <A/T>		<VEHICLES WITH SIDE AIR BAG>..	90-134
.....	90-124	LIGHTING MONITOR TONE ALARM	90-138
		KEY REMINDER TONE ALARM	90-140
		SEAT BELT TONE ALARM	90-142
		RHEOSTAT	90-144

NOTES

HOW TO READ CIRCUIT DIAGRAMS

M3030000100019

The circuit of each system from the fuse (or fusible link) to ground is shown. The power supply is shown at the top and the ground at the bottom to facilitate understanding of how the current flows.

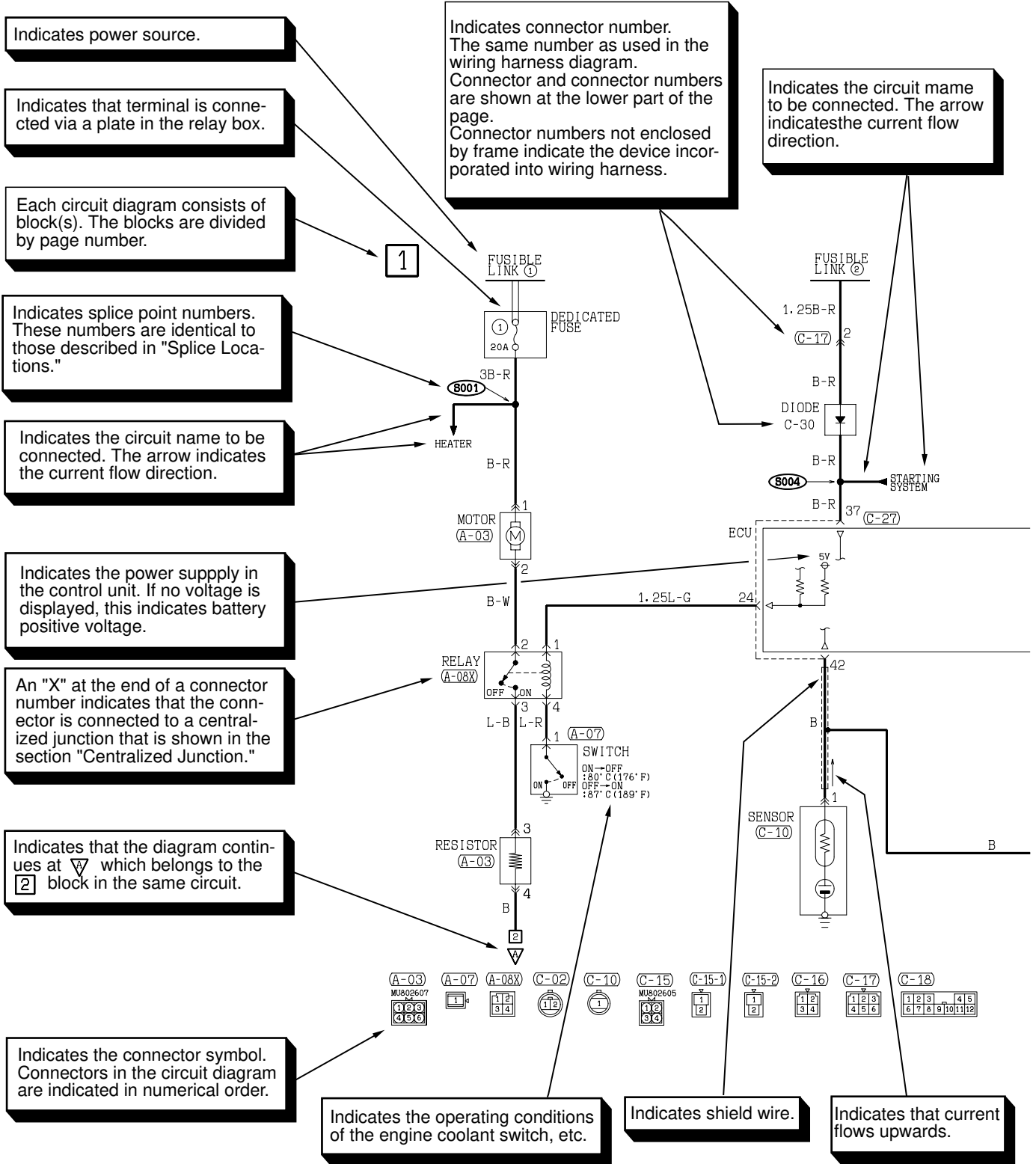

ACX02361AB

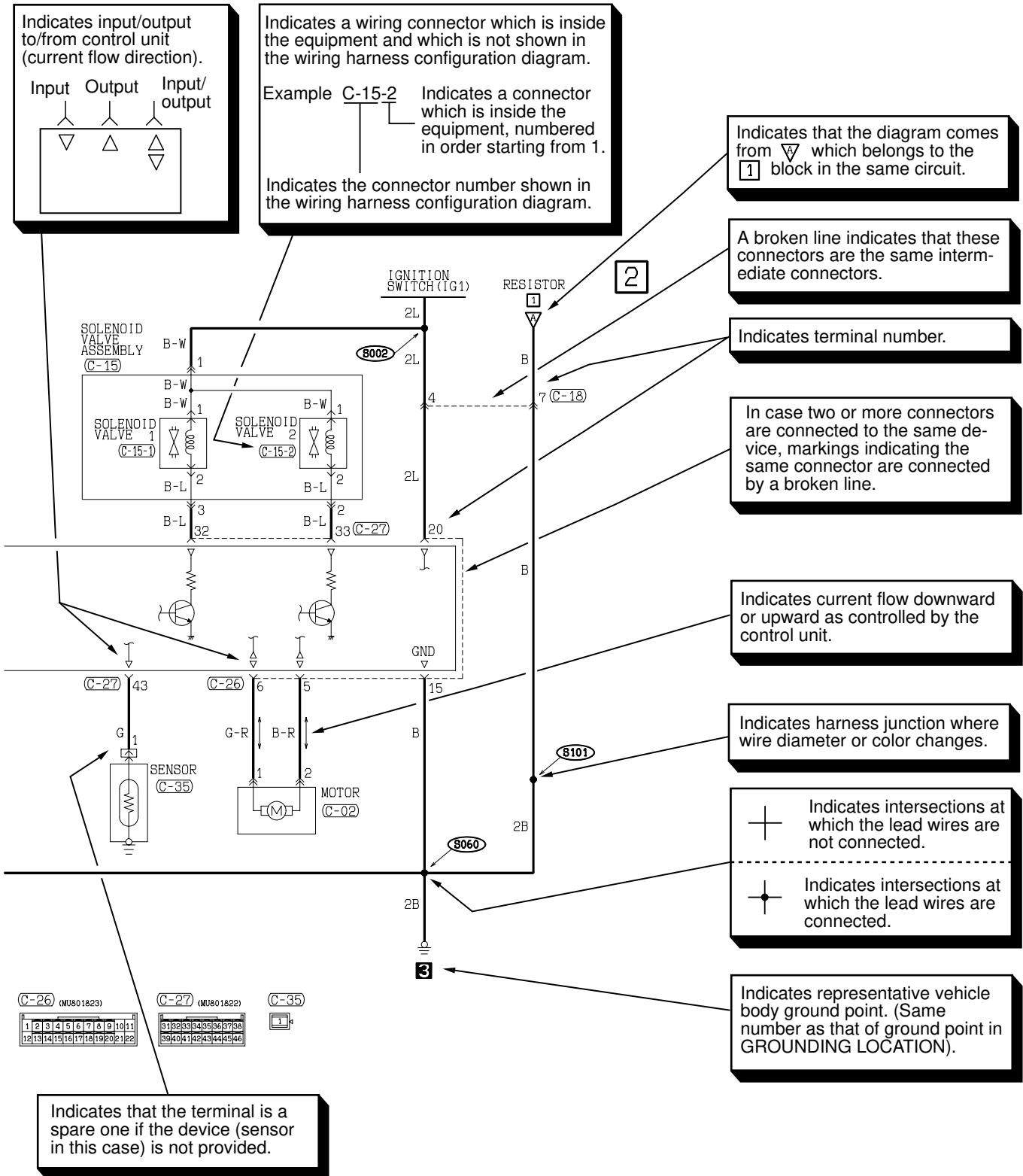



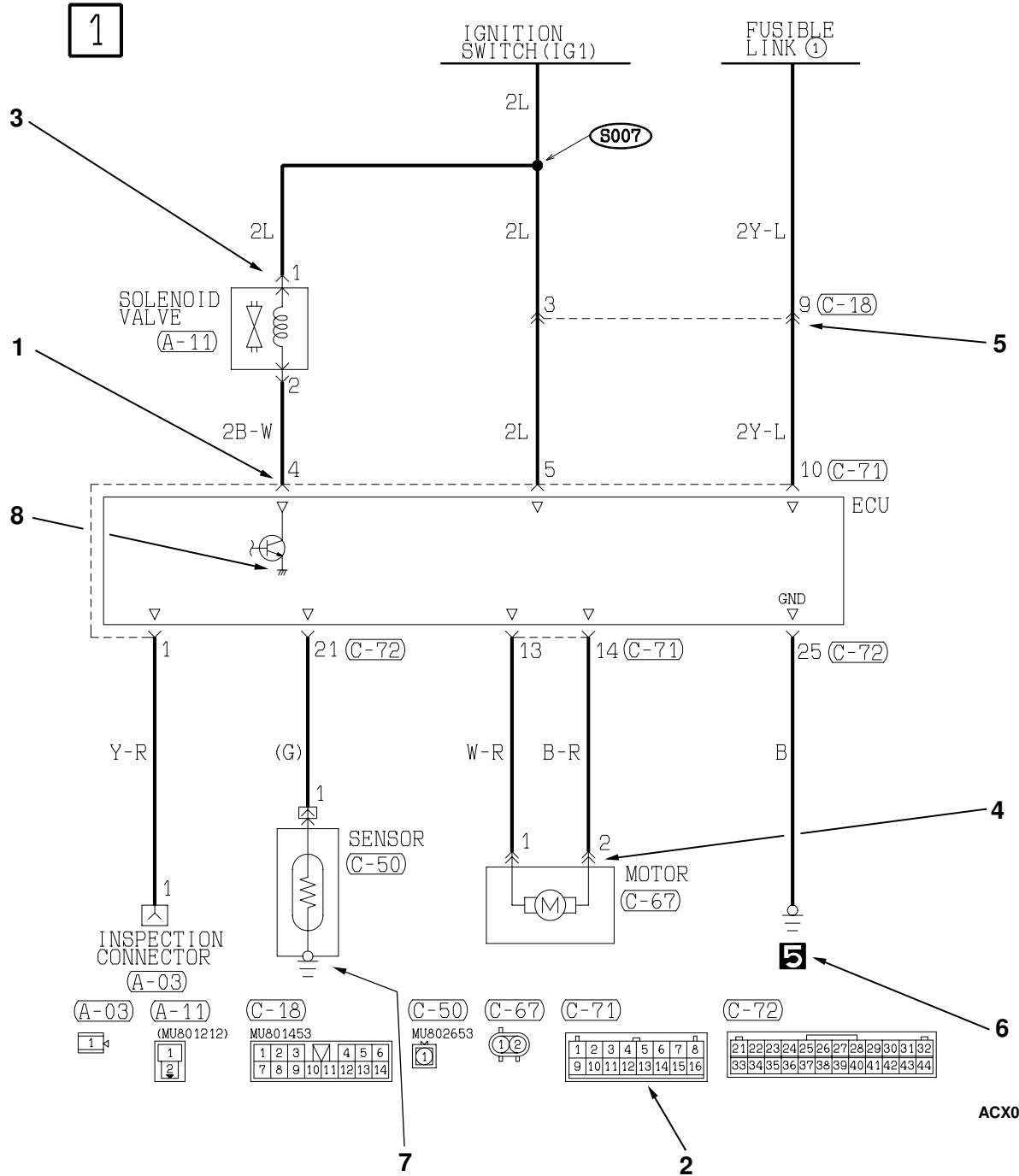



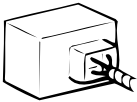
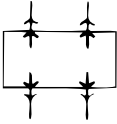
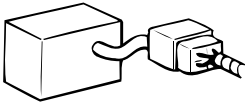
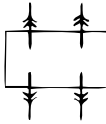
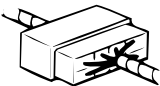

CONNECTOR/GROUNDING INDICATIONS





















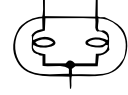

ACX02364AB

ITEM	NO.	CONNECTOR/ GROUNDING	SYMBOL	CONTENTS		
Connector and terminal marking	1	<p align="center">ACX01251 AB</p>	<p>Male terminal</p> <p align="center">ACX01252 AB</p> <p>Male connector</p> <p align="center">ACX01253 AB</p>	<p>The male and female terminals are indicated as shown. The connector with male terminal(s) is called as male connector and indicated by two connector contour lines, while the connector with female terminal(s) is called as female connector and indicated by single connector contour line.</p>		
		<p align="center">ACX01254 AB</p>	<p>Female terminal</p> <p align="center">ACX01255 AB</p> <p>Female connector</p> <p align="center">ACX01256 AB</p>			
		Connector symbol marking	2		<p>Device</p> <p align="center">ACX01257 AB</p>	<p align="center">ACX01253</p>
					<p>Intermediate connector</p> <p align="center">ACX01258 AB</p>	
<p>Spare connector, check connector</p> <p align="center">ACX01816 AB</p>	<p align="center">ACX01256</p>					

ITEM	NO.	CONNECTOR/ GROUNDING	SYMBOL	CONTENTS
Connector connection marking	3	Direct connection type  ACX01260 AB	 ACX01261	Connection between a device and the harness is either by direct insertion in the device (direct connection type) or by connection with a harness connector furnished on the device side furnished (harness connection type). The two types are indicated as illustrated.
	4	Harness connection type  ACX01262 AB	 ACX01263	
	5	Intermediate connector  ACX01264 AB	 ACX01265	
Ground markings	6	Body ground  ACX01273 AB	 ACX01274	Grounding is either by body ground, device ground or control unit interior ground. These are indicated as illustrated.
	7	Device ground  ACX01275 AB	 ACX01276	
	8	Ground in control unit  ACX01277 AB	 ACX01278	

SYMBOLS (EXCEPT CONNECTOR AND GROUNDING)

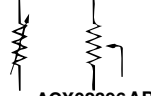
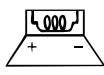
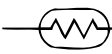
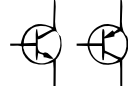
Devices appearing in circuit diagrams are indicated by the following symbols.

battery  ACX02377 AB	buzzer  ACX02378 AB	Capacitor  ACX02379 AB	electrolytic capacitor  ACX02380 AB	Variable capacitor  ACX02381 AB	Coil  ACX02382 AB
diode  ACX02383 AB	light emitting diode  ACX02384 AB	photo diode  ACX02385 AB	Zener diode  ACX02386 AB	dual bulb  ACX02387 AB	Single bulb  ACX02388 AB
Fuse  ACX02389 AB	Fusible link  ACX02390 AB	horn  ACX02391 AB	motor  ACX02392 AB	Pulse generator  ACX02393 AB	Piezoelectric device  ACX02394 AB
Resistor  ACX02395 AB	Variable resistor  ACX02396 AB	Speaker  ACX02397 AB	Thermistor  ACX02398 AB	Transistor  ACX02399 AB	photo transistor  ACX02400 AB

WIRE COLOR CODES

Wire color are identified by the following color codes.

CODE	WIRE COLOR	CODE	WIRE COLOR	CODE	WIRE COLOR	CODE	WIRE COLOR
B	Black	L	Blue	R	Red	Y	Yellow
BR	Brown	LG	Light green	SB	Sky blue	-	-
G	Green	O	Orange	V	Violet	-	-
GR	Gray	P	Pink	W	White	-	-

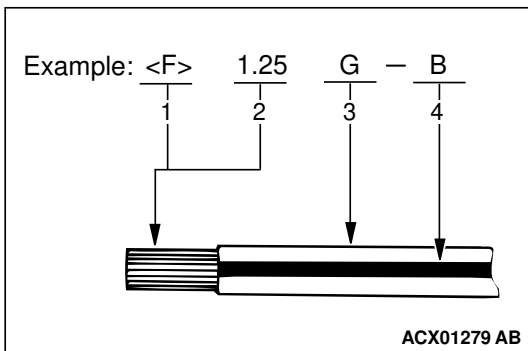

If a cable has two colors, the first of the two color code characters indicates the basic color (color of the cable coating) and the second indicates the marking color.

NO.	MEANING
1	<F>: Flexible wire
	<T>: Twisted wire
2	Wire size (mm ²)*
3	Basic color (color of the cable coating)
4	Marking color

NOTE:

*: No code indicates 0.5 mm² (0.0008 in²). Cable color code in parentheses indicates 0.3 mm² (0.0005 in²).

JUNCTION BLOCK

M3030000200027

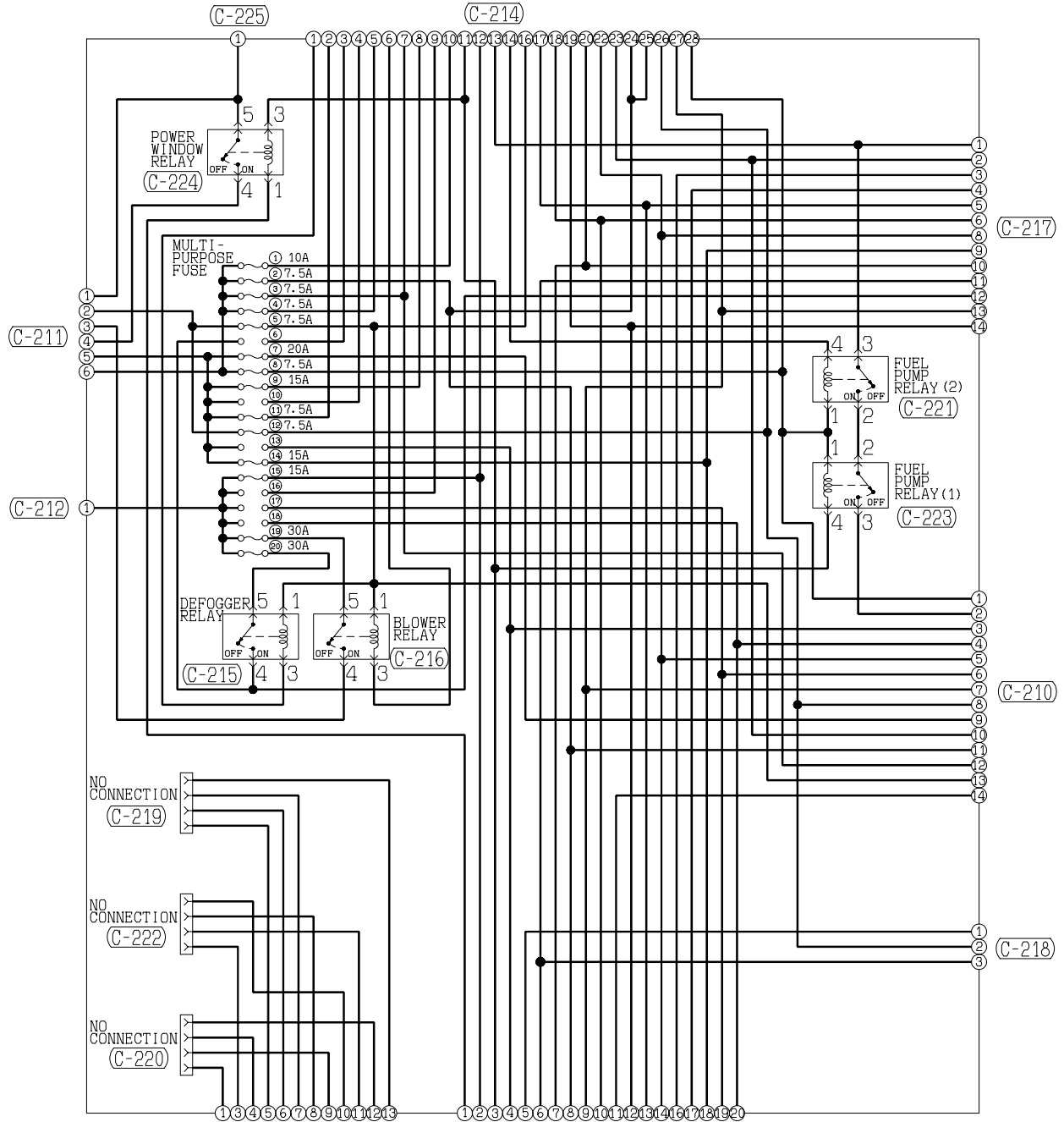

NOTE
CONNECTOR NUMBERS ARE KEYED TO THE CONFIGURATION
DIAGRAM (DASH PANEL) AND EACH CIRCUIT DIAGRAM.

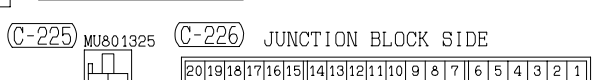
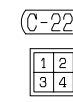
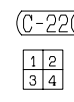
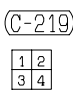
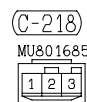
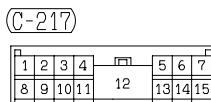
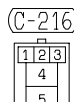
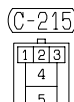
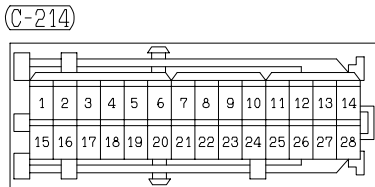
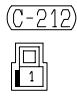
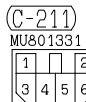
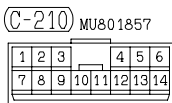
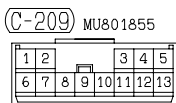

H2J00M00AA

FRONT SIDE

REAR SIDE

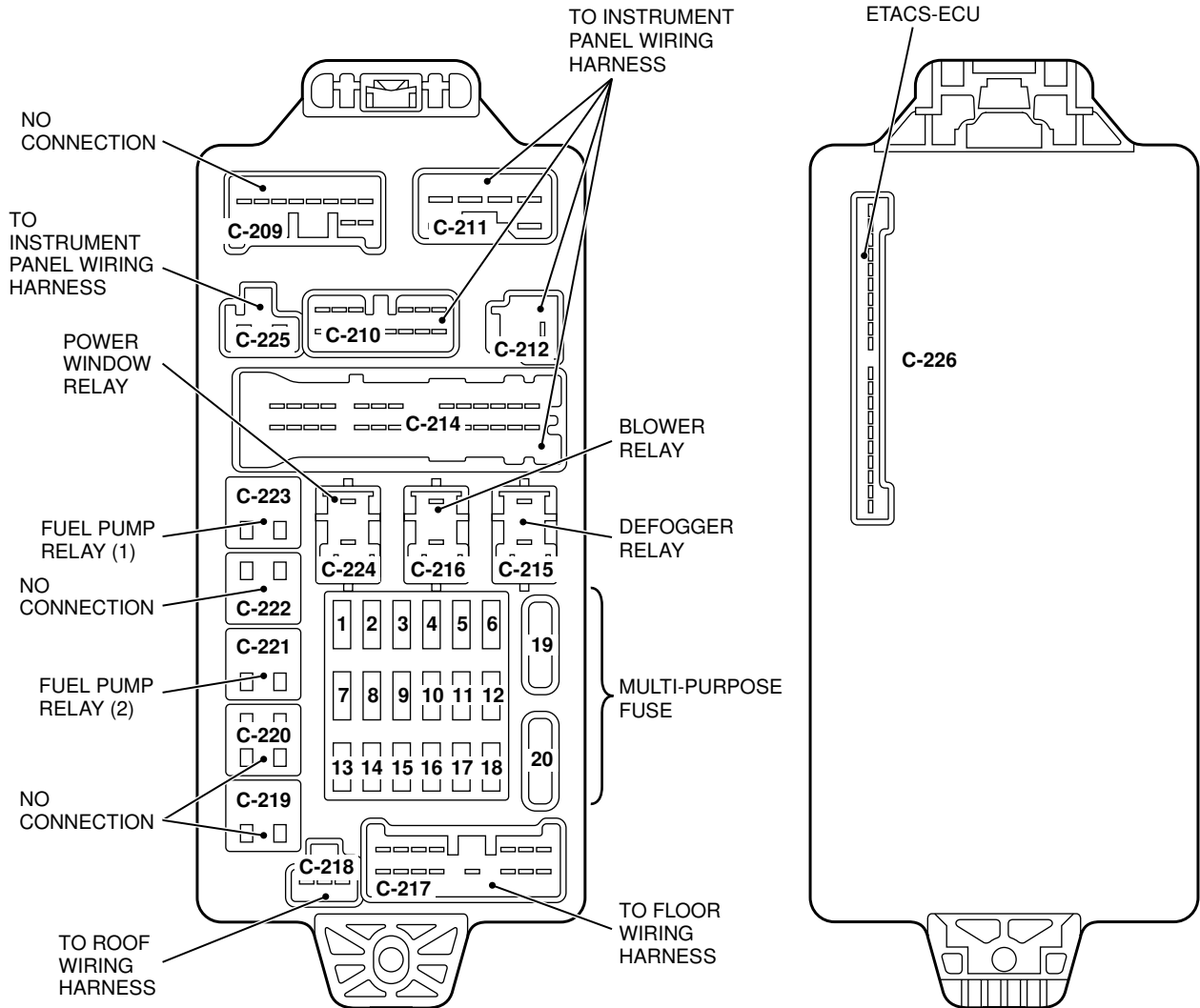

AC100233AB

JOINT CONNECTOR

M3030014200020

NOTE

IN THE ACTUAL VEHICLE, SOME OF THE JOINT CONNECTOR TERMINALS IN THE SAME BUS ARE USED, SO IN SOME CASES, THE TERMINALS INDICATED ON THE CIRCUIT DIAGRAMS DO NOT AGREE WITH THE ONES IN THE ACTUAL VEHICLE.

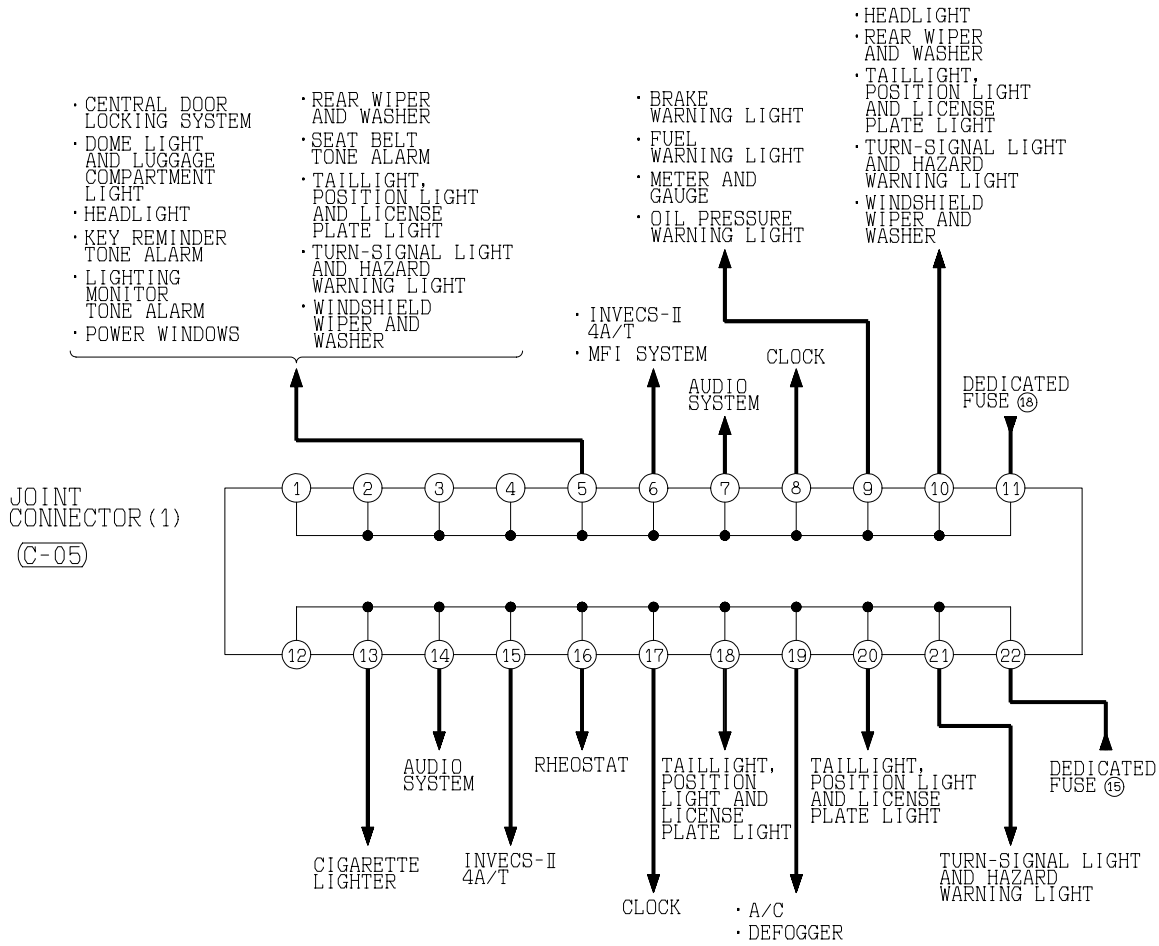

(C-05)

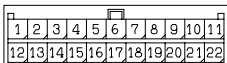

(C-101)

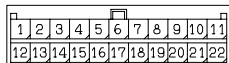

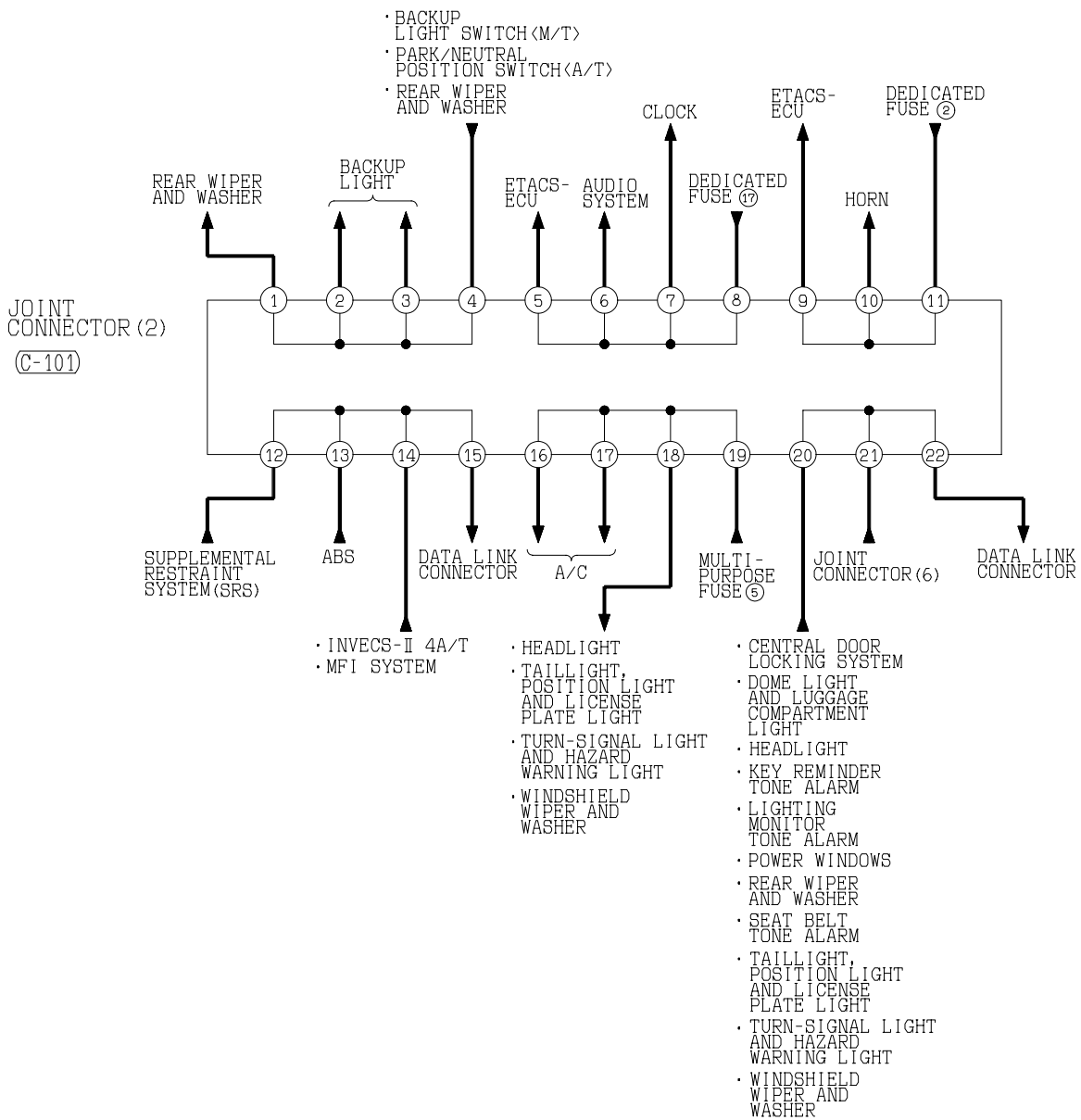

JOINT CONNECTOR (CONTINUED)

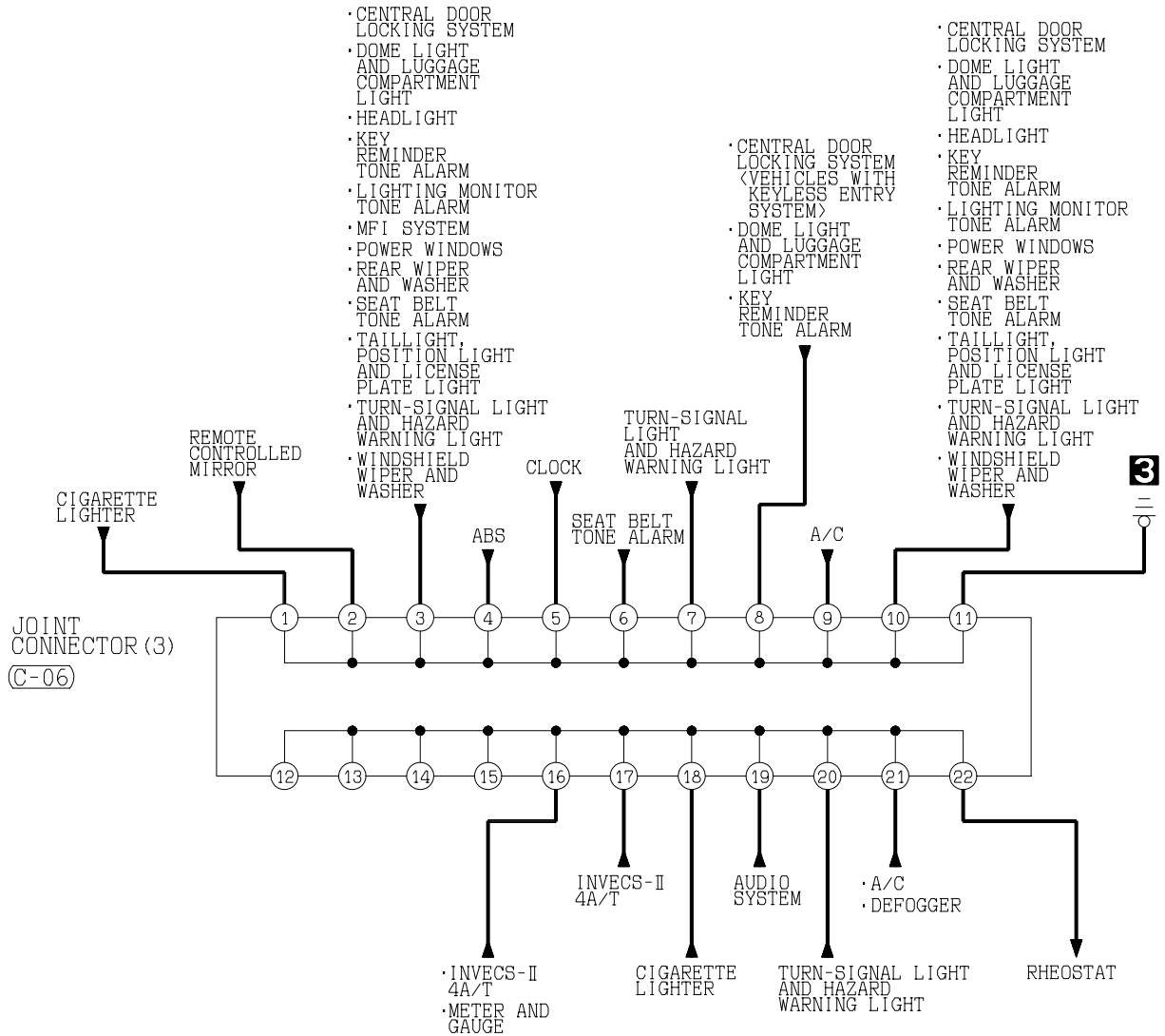

(C-06)

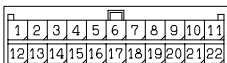

(C-21)

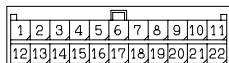

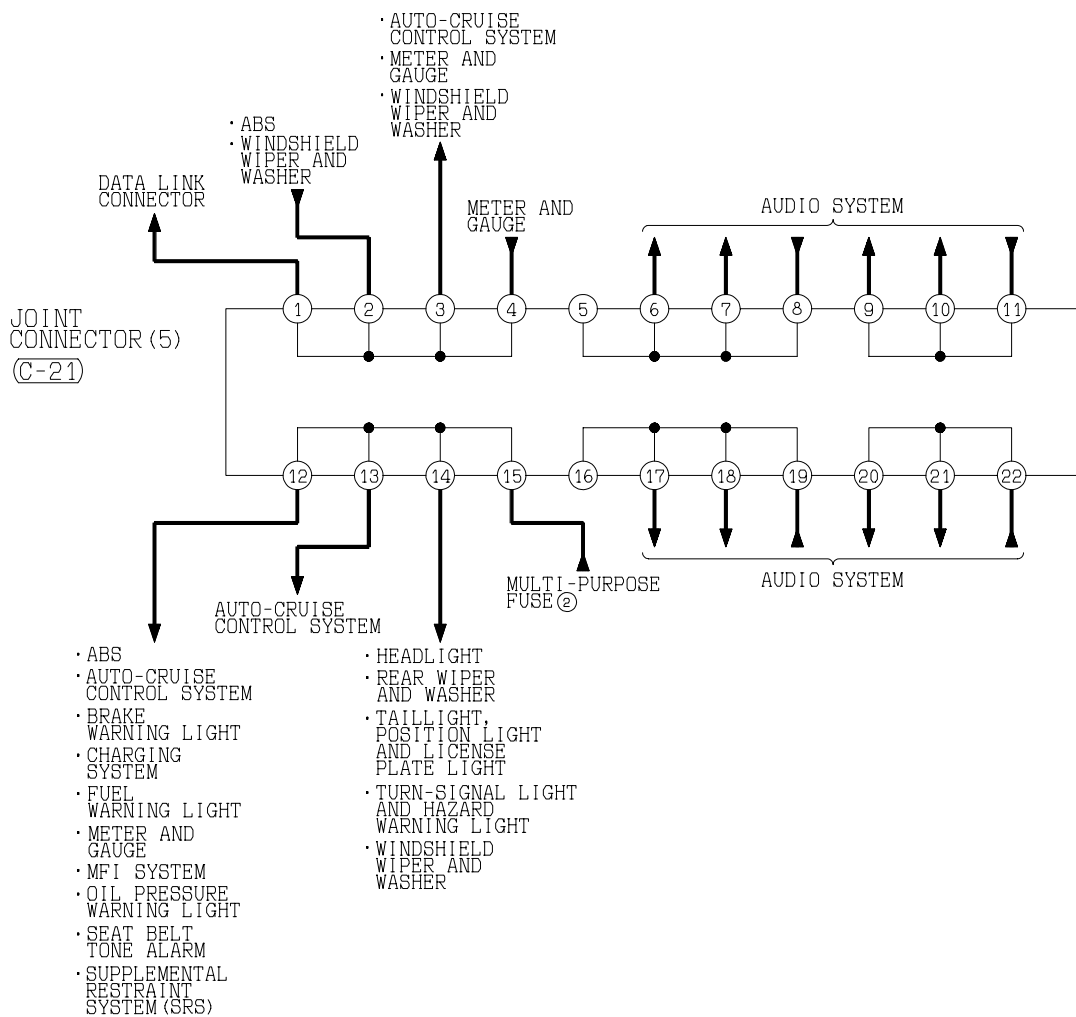

JOINT CONNECTOR (CONTINUED)

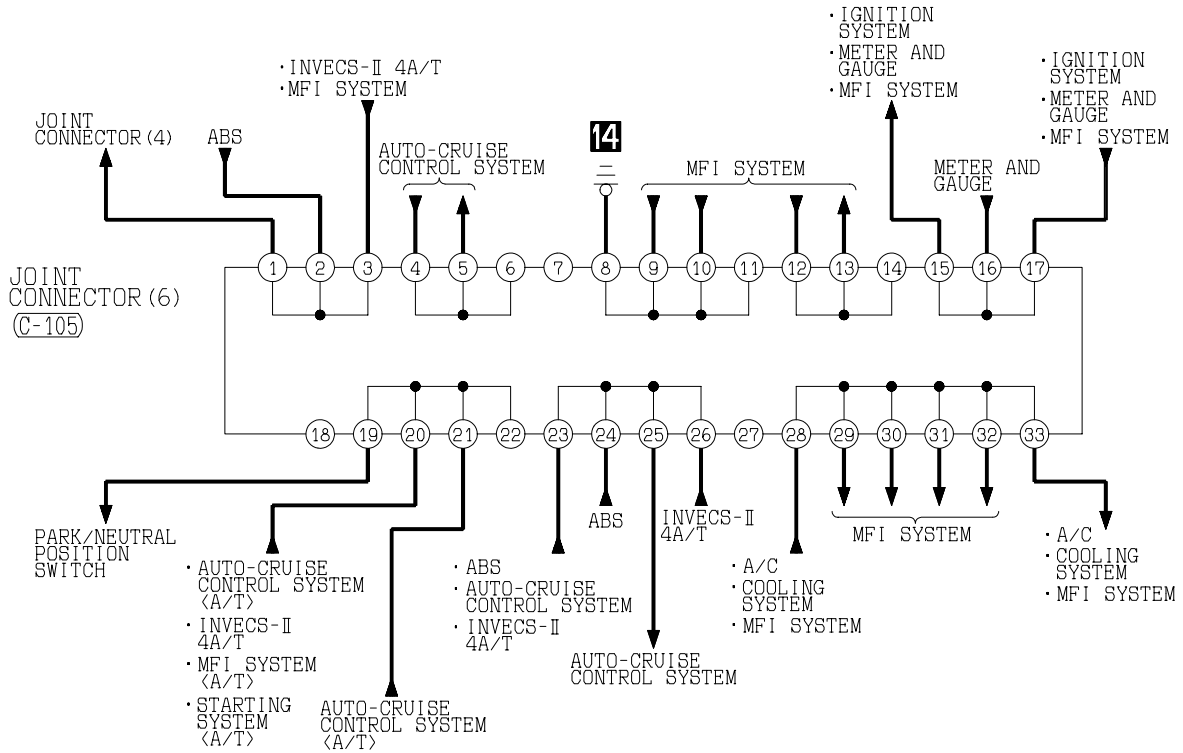

(C-105)

1	2	3	4	5	6	7	8	9	10	11
12	13	14	15	16	17	18	19	20	21	22
23	24	25	26	27	28	29	30	31	32	33

NOTES

CENTRALIZED JUNCTION

M3030000300024

FUSIBLE LINK

NO.	CIRCUIT	TYPE	HOUSING COLOR	RATED CAPACITY (A)
1	Multi-purpose fuses No.15, 16, 17, 18, 19, 20	Screwed type	Yellow	60
2	Air conditioning circuit and cooling circuit	Connector type	Red	50
3	ABS circuit	Connector type	Yellow	60
4	Ignition switch	Connector type	Green	40
5	Power windows circuit	Connector type	Pink	30
6	Battery, fusible links No.1, 2, 3, 4, 5, dedicated fuses No.1, 2, 3, 4, 5, 6, 7, 8, 9, 10, 18, starting system and front-ECU	Screwed type	-	100

(RELAY BOX IN ENGINE COMPARTMENT)

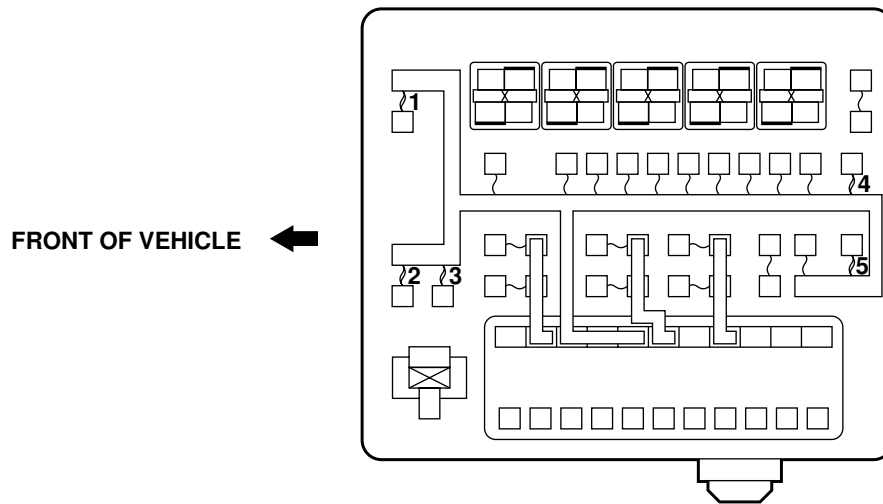

(CONNECTED DIRECTLY TO BATTERY POSITIVE (+) TERMINAL)

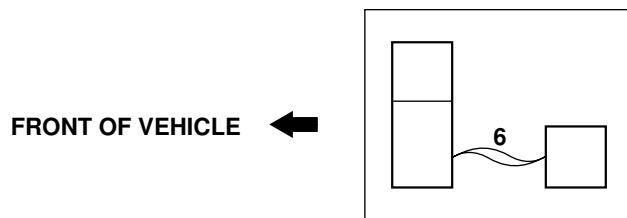

AC100234AB

DEDICATED FUSE

POWER SUPPLY CIRCUIT	NO.	RATED CAPACITY (A)	HOUSING COLOR	CIRCUIT
Battery/alternator (Fusible link No.6)	1	–	–	–
	2	10	Red	Horn relay
	3	20	Yellow	MFI relay
	4	10	Red	A/C compressor relay
	5	15	Blue	ABS-ECU, powertrain control module, high-mounted stop light and rear combination light
	6	–	–	–
	7	7.5	Brown	Alternator
	8	10	Red	ETACS-ECU
	9	20	Yellow	A/T control solenoid valve assembly and powertrain control module
	10	15	Blue	Fuel pump
Front-ECU (Headlight relay: High)	11	10	Red	Headlight and high-beam indicator light
	12	10	Red	Headlight
Front-ECU (Headlight relay: Low)	13	10	Red	Headlight
	14	10	Red	Headlight
Front-ECU (Taillight relay)	15	7.5	Brown	A/C-ECU, clock, combination meter, hazard warning switch, license plate light, position light, radio, CD player, rear combination light and taillight
	16	7.5	Brown	Combination meter, license plate light, position light, rear combination light and taillight
Ignition switch (ACC)	17	10	Red	Clock, ETACS-ECU and radio, CD player
Battery/alternator (Fusible link No.6)	18	10	Red	Clock, column switch, engine control module, ETACS-ECU, front-ECU, radio, CD player and powertrain control module
–	19	–	–	–
–	20	–	–	–
–	21	–	–	–
–	22	–	–	–
–	23	–	–	–

(RELAY BOX IN ENGINE COMPARTMENT)

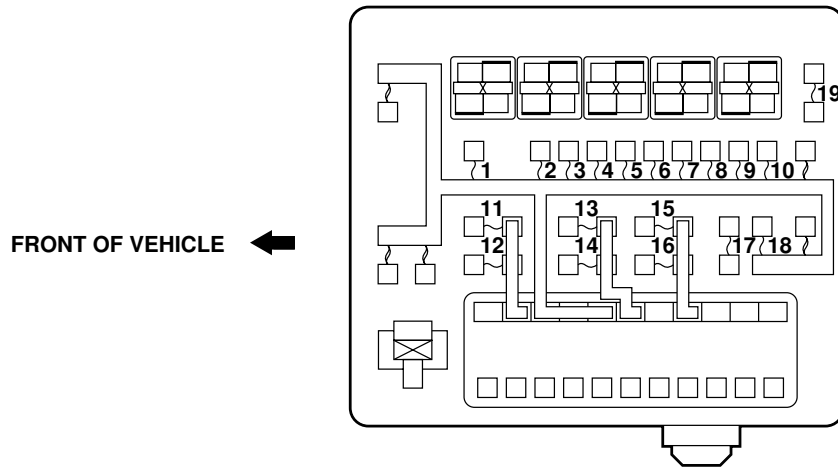

(IN JUNCTION BLOCK)

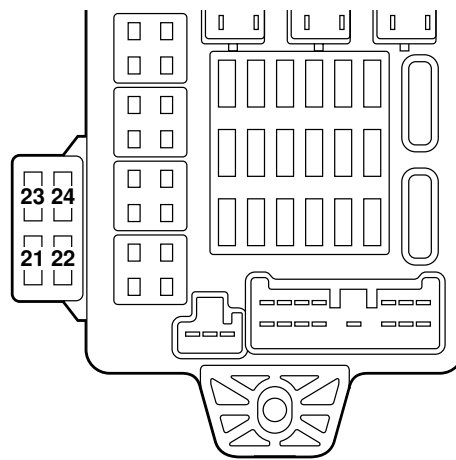

AC100235AB

MULTI-PURPOSE FUSE

POWER SUPPLY CIRCUIT		NO.	RATED CAPACITY (A)	HOUSING COLOR	LOAD CIRCUIT
Ignition switch	IG1	1	10	Red	Ignition coil
		2	7.5	Brown	Charging warning light, check engine warning light, column switch, combination meter, ETACS-ECU, SRS-ECU, vehicle speed sensor and auto-cruise control-ECU
		3	7.5	Brown	A/T control relay, combination meter, ETACS-ECU, input shaft speed sensor, output shaft speed sensor, powertrain control module, rear combination light, shift switch and SRS-ECU
		4	7.5	Brown	Auto-cruise control-ECU
	IG2	5	7.5	Brown	A/C compressor relay, A/C-ECU, blower relay, defogger relay, front-ECU and outside/inside air selection damper control motor
Fusible link No.20 (Defogger relay)		6	–	–	–
Ignition switch	ACC	7	20	Yellow	Front-ECU and windshield wiper motor
	IG1	8	7.5	Brown	Fuel pump relay (1), fuel pump relay (2), engine control module and powertrain control module
	ACC	9	15	Blue	Cigarette lighter
		10	–	–	–
		11	7.5	Brown	Remote control mirror switch
	IG2	12	7.5	Brown	ABS-ECU and ABS warning light relay
	ACC	13	–	–	–
		14	15	Blue	ETACS-ECU
Fusible link No.1 Battery/alternator		15	15	Blue	Diagnosis connector and ETACS-ECU
		16	–	–	–
		17	–	–	–
		18	–	–	–
		19	30	Green	Blower motor and resistor
		20	30	Green	Choke coil and defogger

(IN JUNCTION BLOCK)

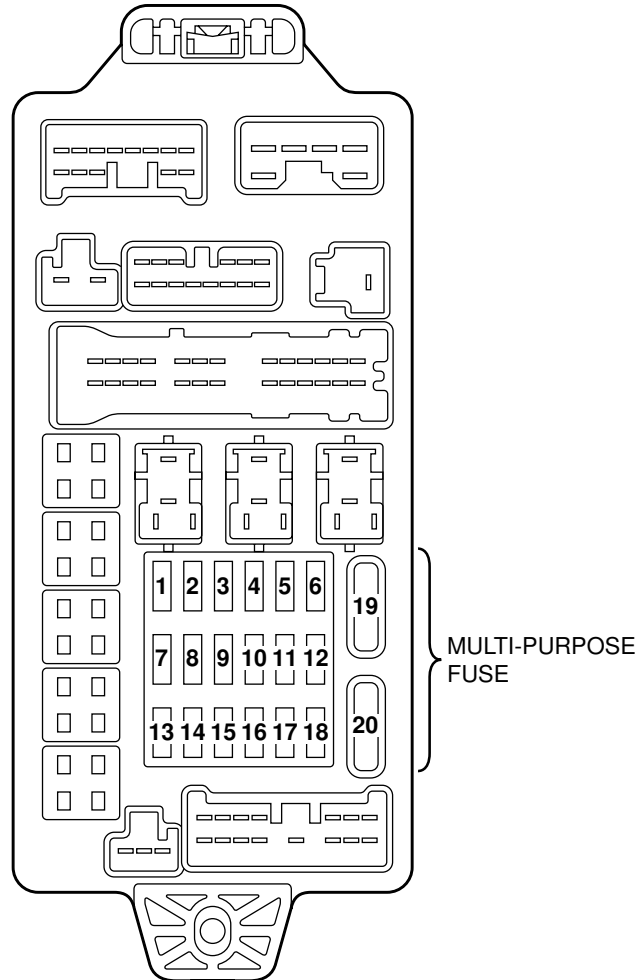

AC100236AB

CENTRALIZED RELAY

CONNECTOR NO.	NAME	CONNECTOR NO.	NAME
A-04X	–	B-06X	Engine speed detection connector
A-05X	Horn relay	B-07X	Starter relay <M/T>
A-06X	–	B-08X	–
A-07X	–	B-09X	–
A-08X	–	B-10X	–
A-09X	Fan control relay	B-11X	A/T control relay
A-10X	Front-ECU	B-12X	MFI relay
A-11X	Front-ECU	B-13X	A/C compressor relay

(RELAY BOX IN ENGINE COMPARTMENT)

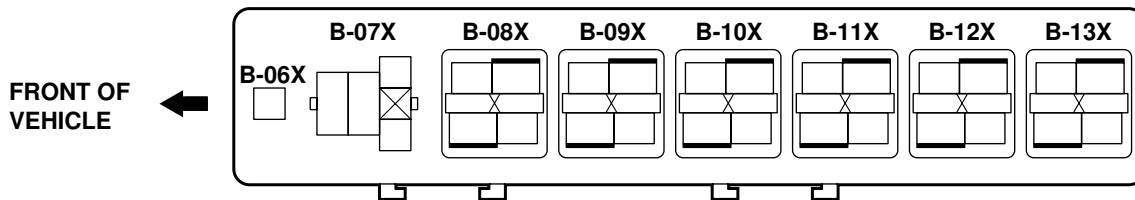
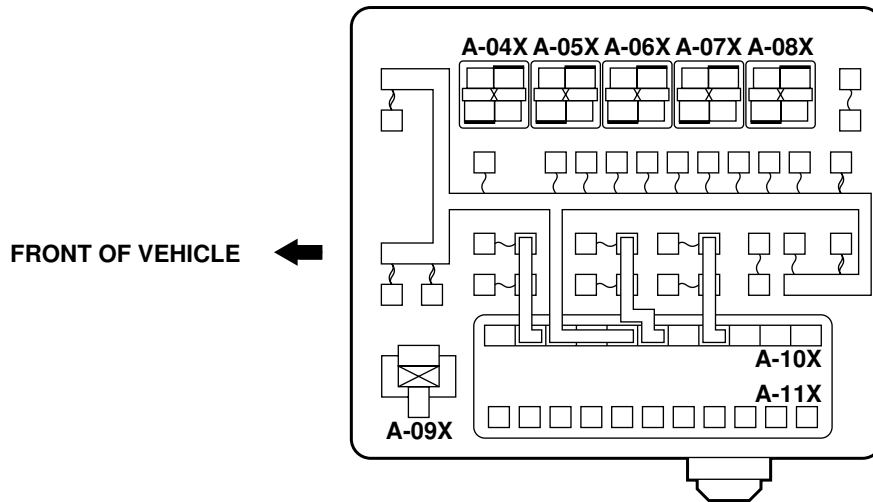

AC100237AB

POWER DISTRIBUTION SYSTEM

M3030000400043

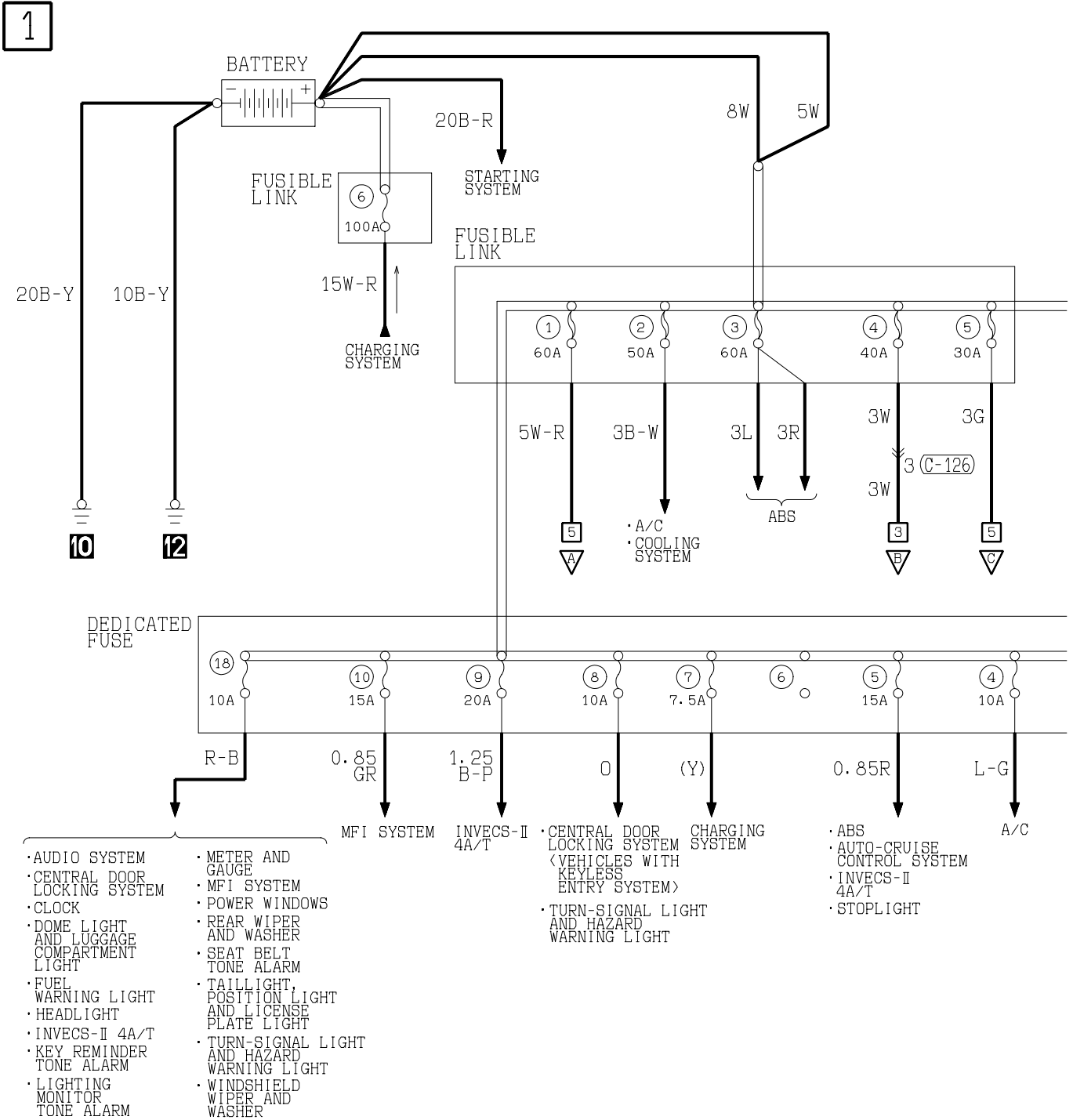

- (A-10X) [1][2][3][4][5][6][7][8][9][10][11]
- (C-126) [1][2][3]

H2J01M00AA

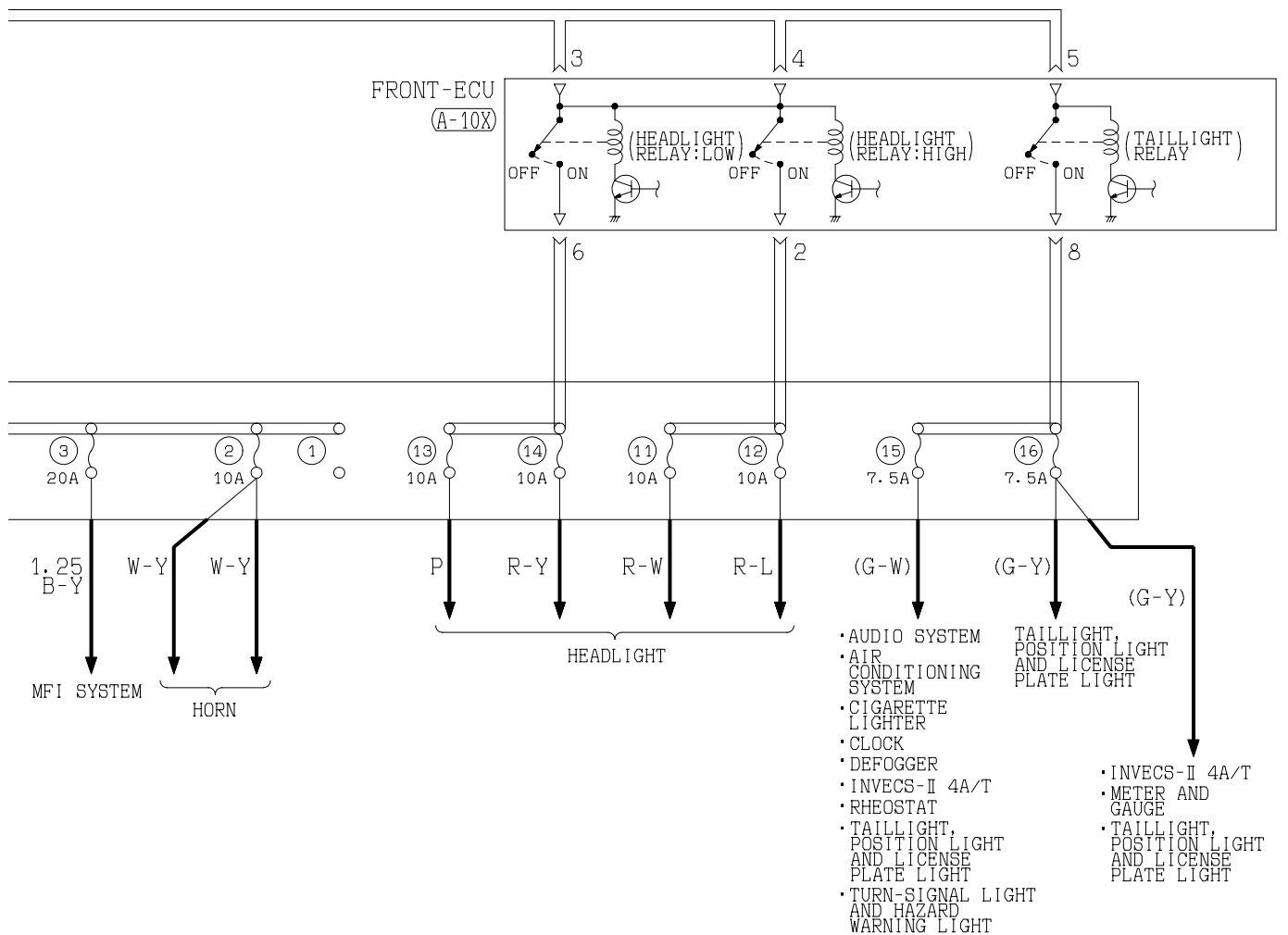

WIRE COLOR CODE

POWER DISTRIBUTION SYSTEM (CONTINUED)

3

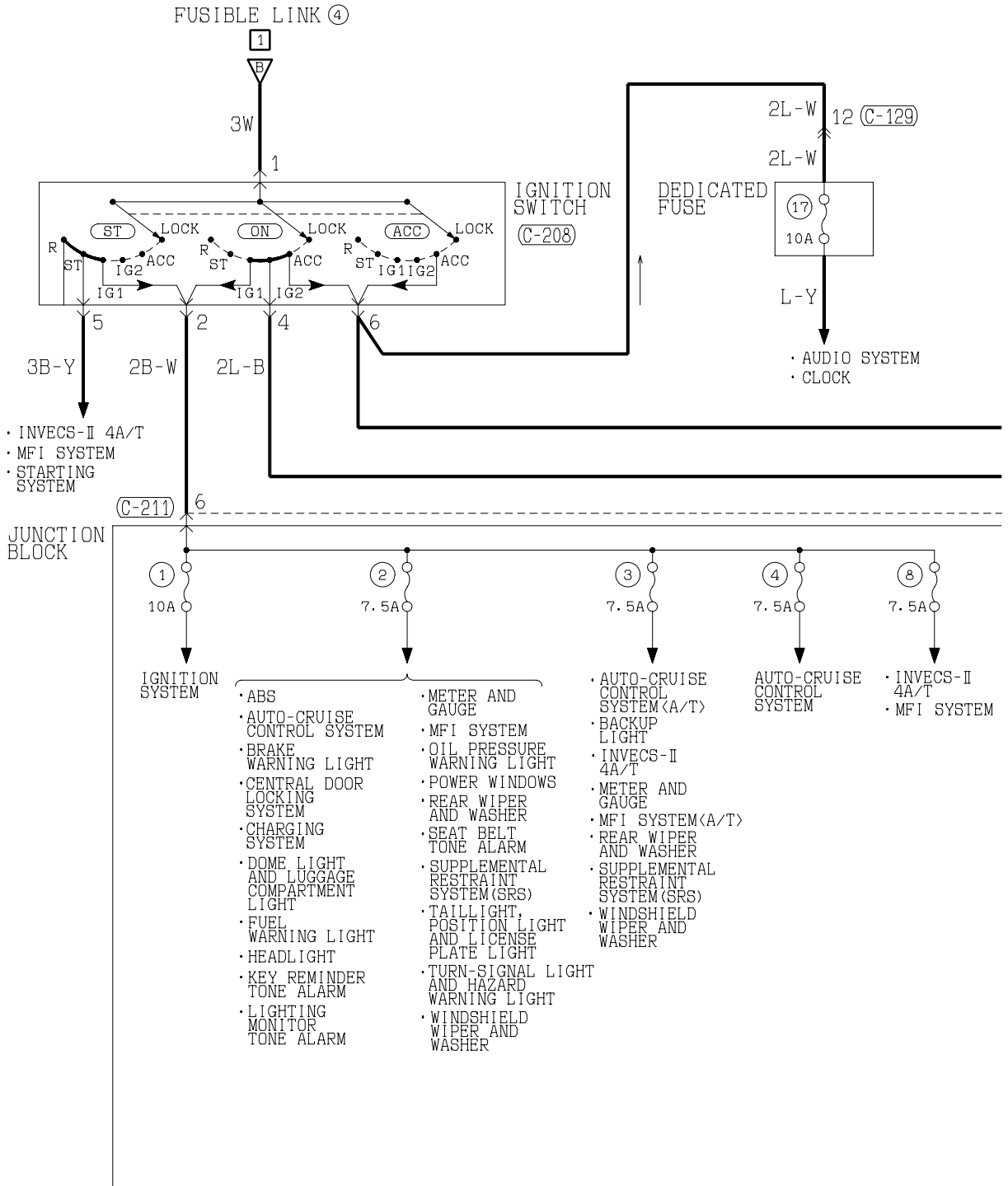

(C-129)

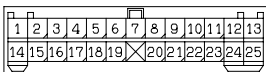

(C-208)



(C-211)

MU801331



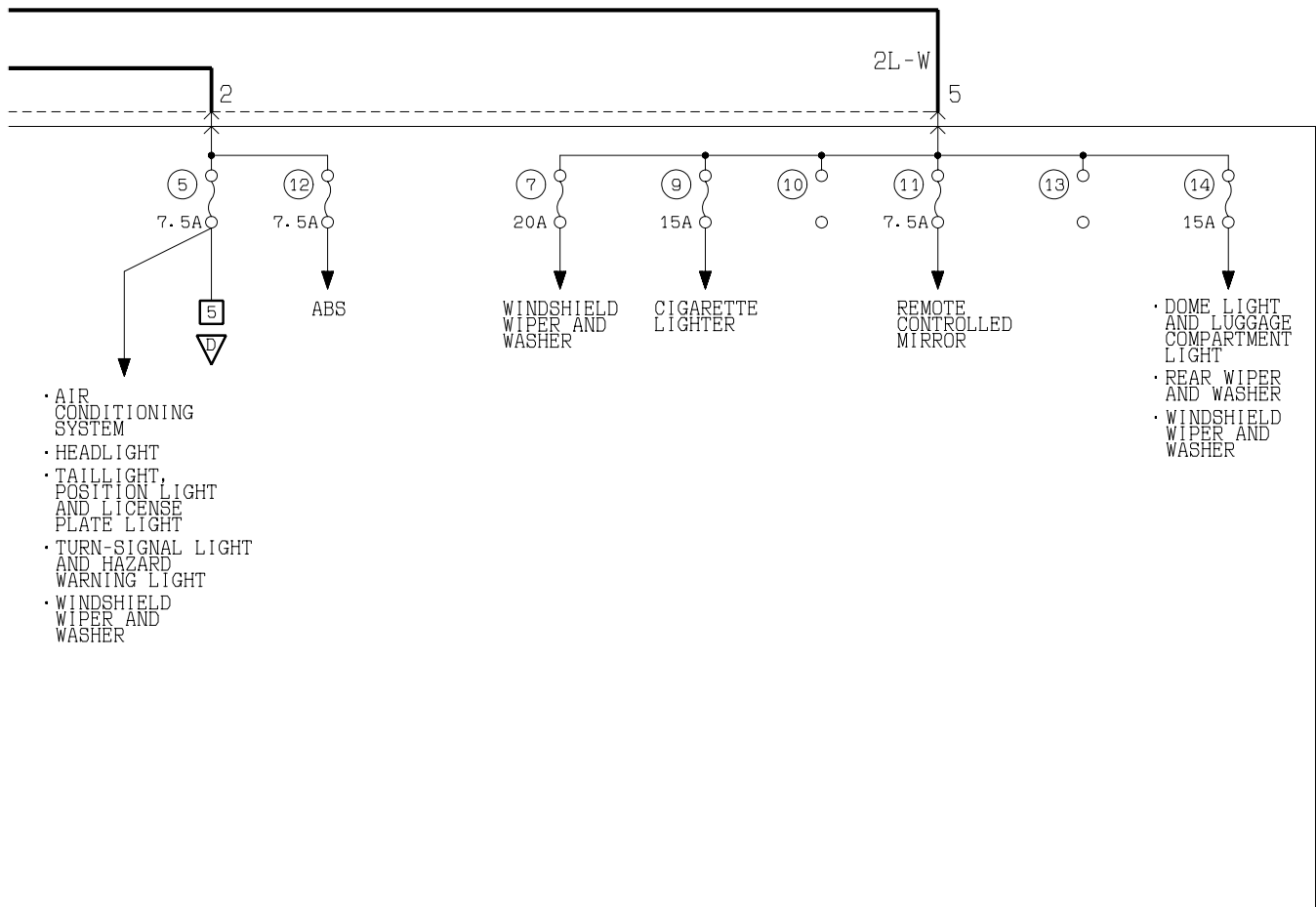

WIRE COLOR CODE
 B : BLACK LG : LIGHT GREEN G : GREEN L : BLUE W : WHITE Y : YELLOW SB : SKY BLUE
 BR : BROWN O : ORANGE GR : GRAY R : RED P : PINK V : VIOLET

POWER DISTRIBUTION SYSTEM (CONTINUED)

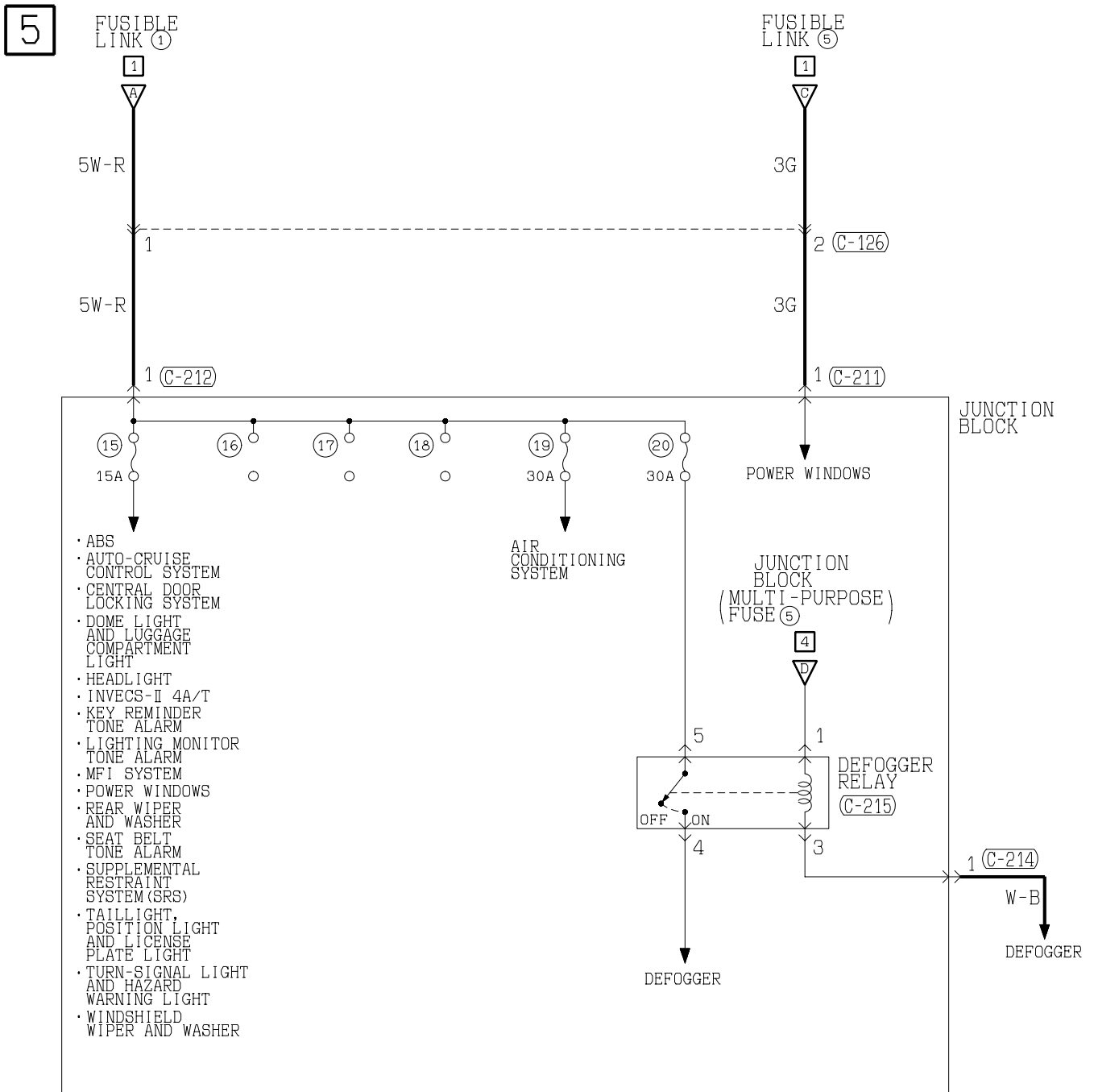

WIRE COLOR CODE
B : BLACK LG : LIGHT GREEN
BR : BROWN O : ORANGE

G : GREEN L : BLUE W : WHITE Y : YELLOW
GR : GRAY R : RED P : PINK V : VIOLET

SB : SKY BLUE

H2J01M00CA

NOTES

STARTING SYSTEM <M/T>

M3030000500040

1

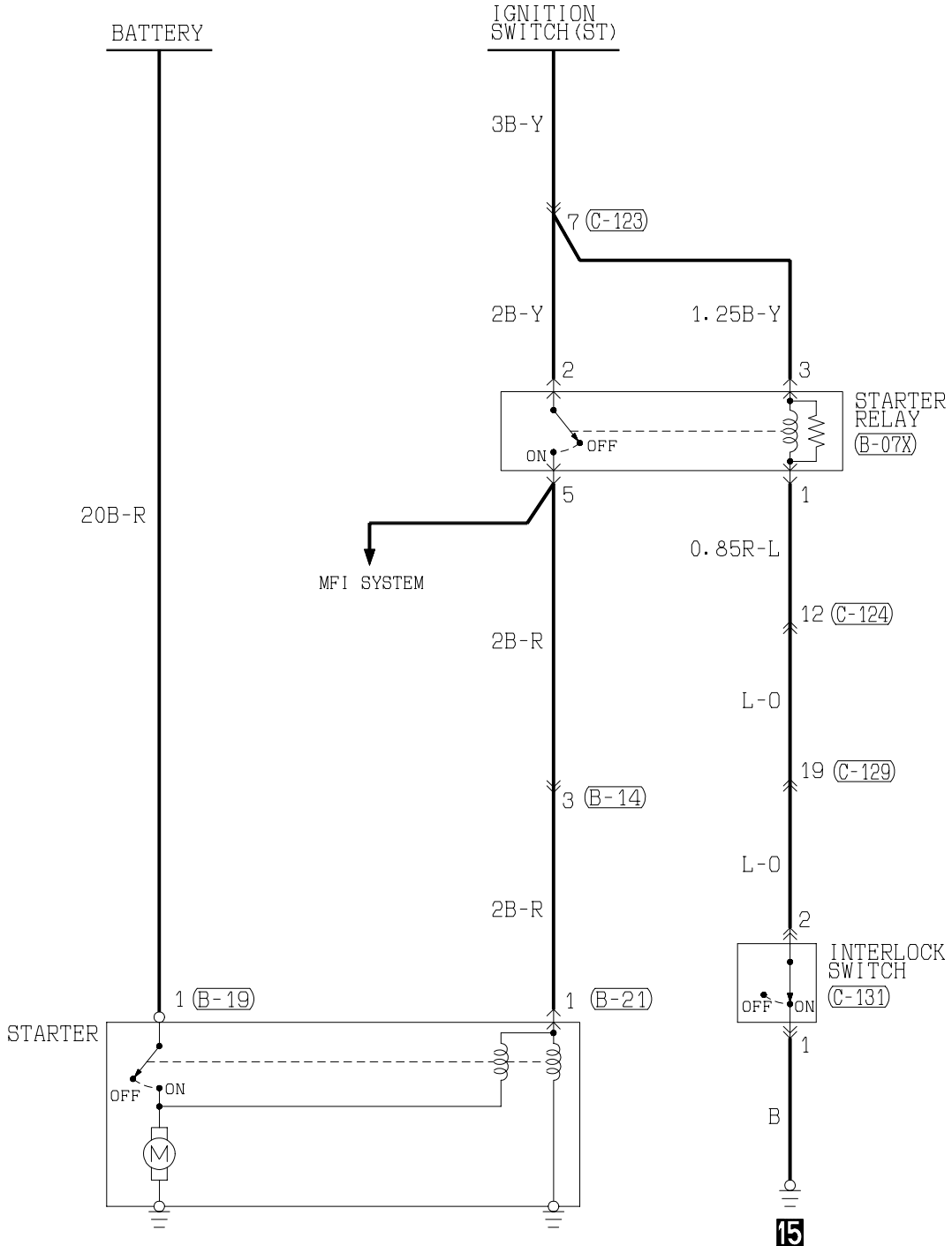

15

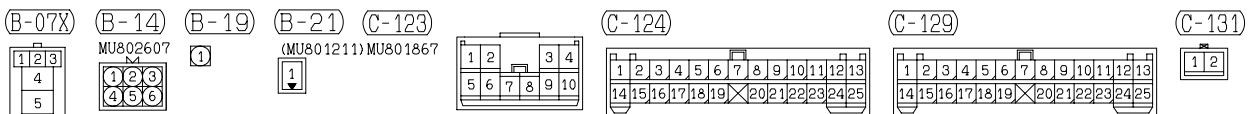

WIRE COLOR CODE
 B : BLACK LG : LIGHT GREEN G : GREEN L : BLUE W : WHITE Y : YELLOW SB : SKY BLUE
 BR : BROWN O : ORANGE GR : GRAY R : RED P : PINK V : VIOLET

H2J02M00AA

TSB Revision

STARTING SYSTEM <A/T>

M3030000500051

1

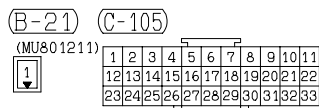
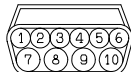
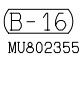
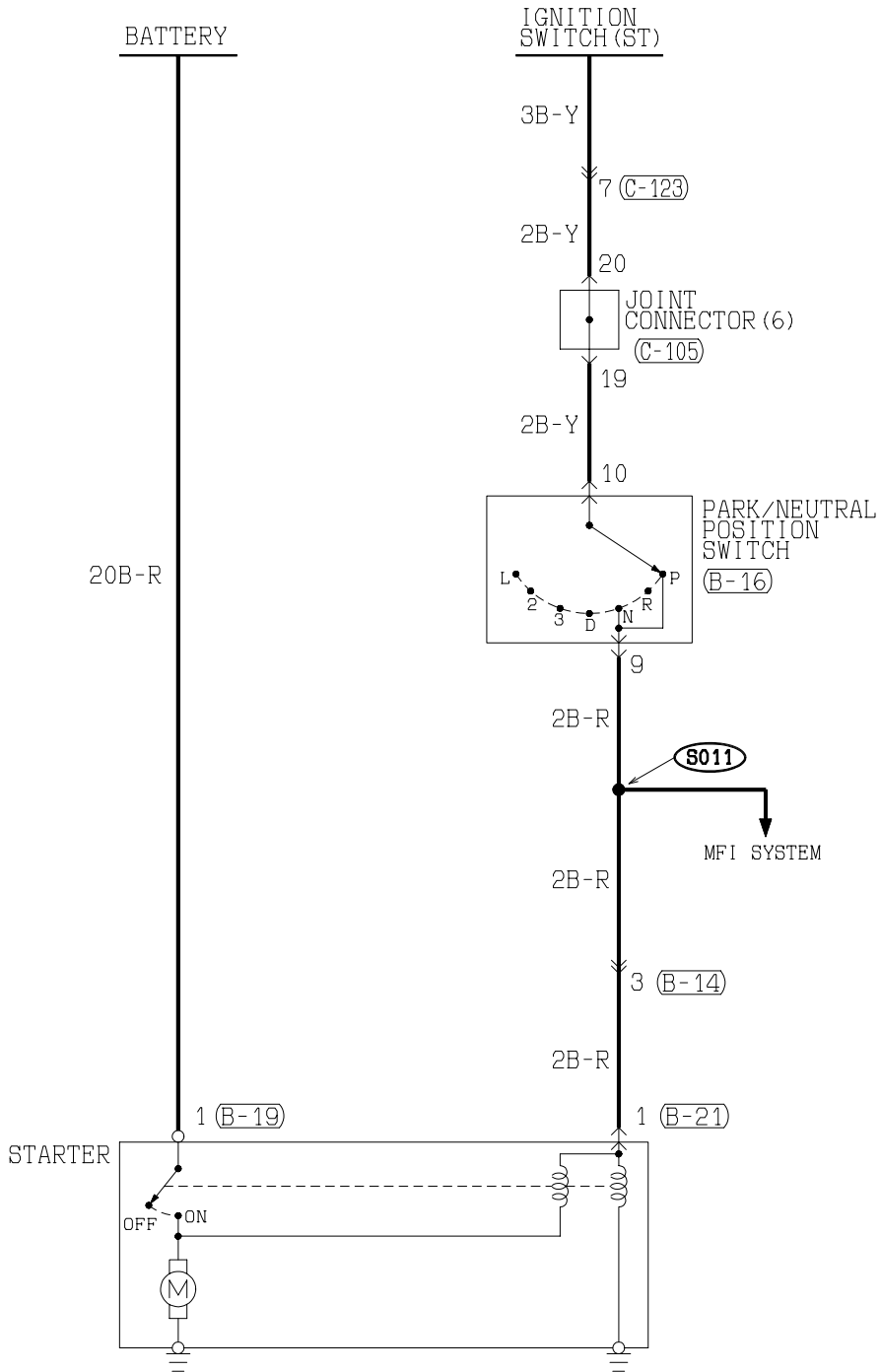

WIRE COLOR CODE
 B : BLACK LG : LIGHT GREEN G : GREEN L : BLUE W : WHITE Y : YELLOW SB : SKY BLUE
 BR : BROWN O : ORANGE GR : GRAY R : RED P : PINK V : VIOLET

H2J02M01AA

TSB Revision

IGNITION SYSTEM <M/T>

M3030000600081

1

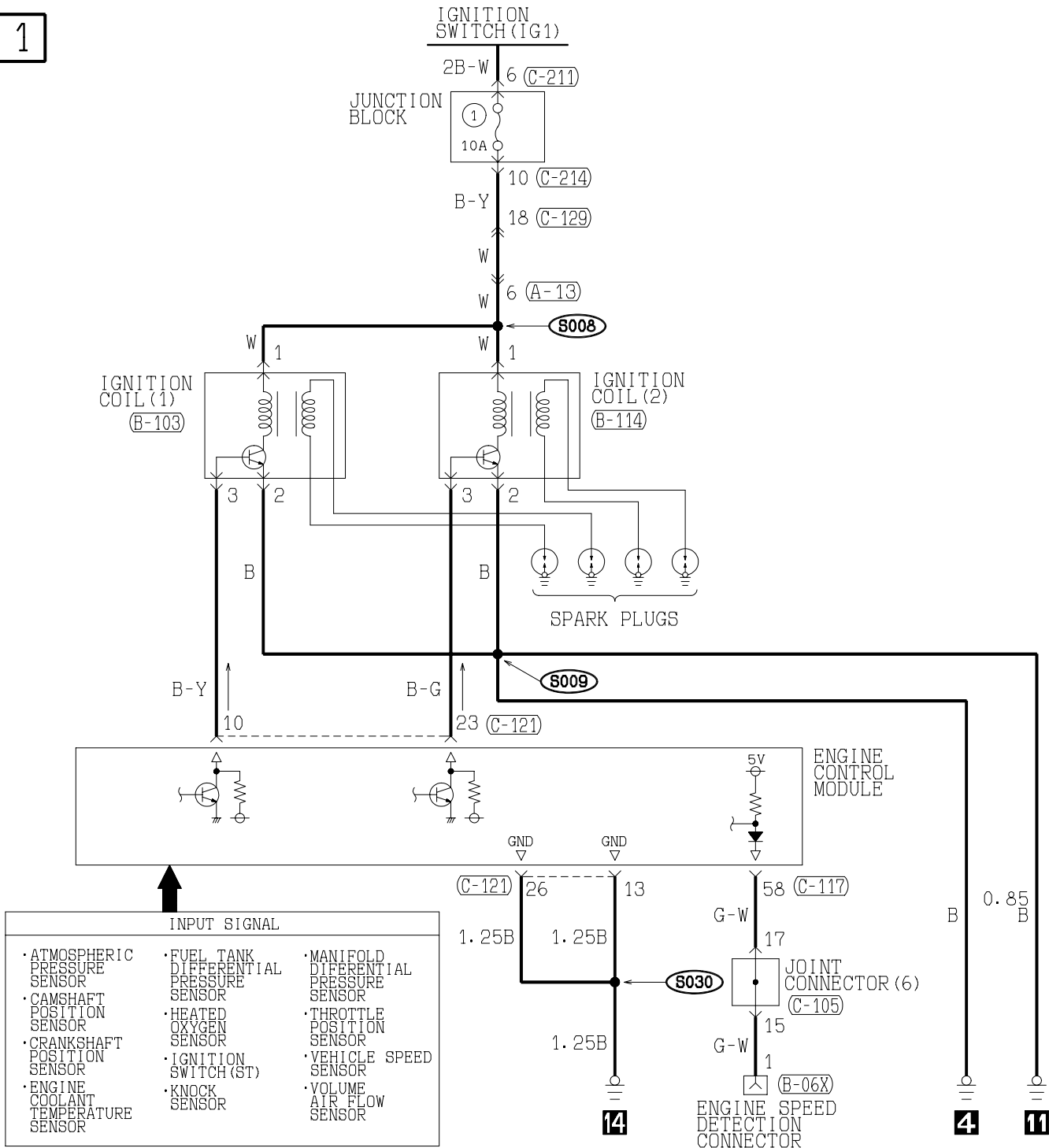

- INPUT SIGNAL**
- ATMOSPHERIC PRESSURE SENSOR
 - FUEL TANK DIFFERENTIAL PRESSURE SENSOR
 - MANIFOLD DIFFERENTIAL PRESSURE SENSOR
 - CAMSHAFT POSITION SENSOR
 - HEATED OXYGEN SENSOR
 - THROTTLE POSITION SENSOR
 - CRANKSHAFT POSITION SENSOR
 - IGNITION SWITCH (ST)
 - VEHICLE SPEED SENSOR
 - ENGINE COOLANT TEMPERATURE SENSOR
 - KNOCK SENSOR
 - VOLUME AIR FLOW SENSOR

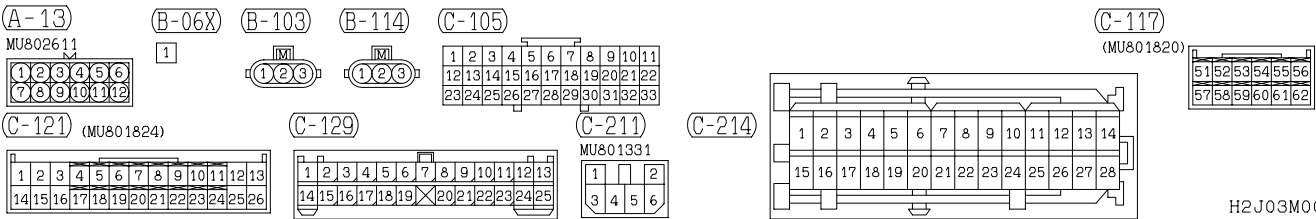

TSB Revision

H2J03M00AA

IGNITION SYSTEM <A/T>

M3030000600092

1

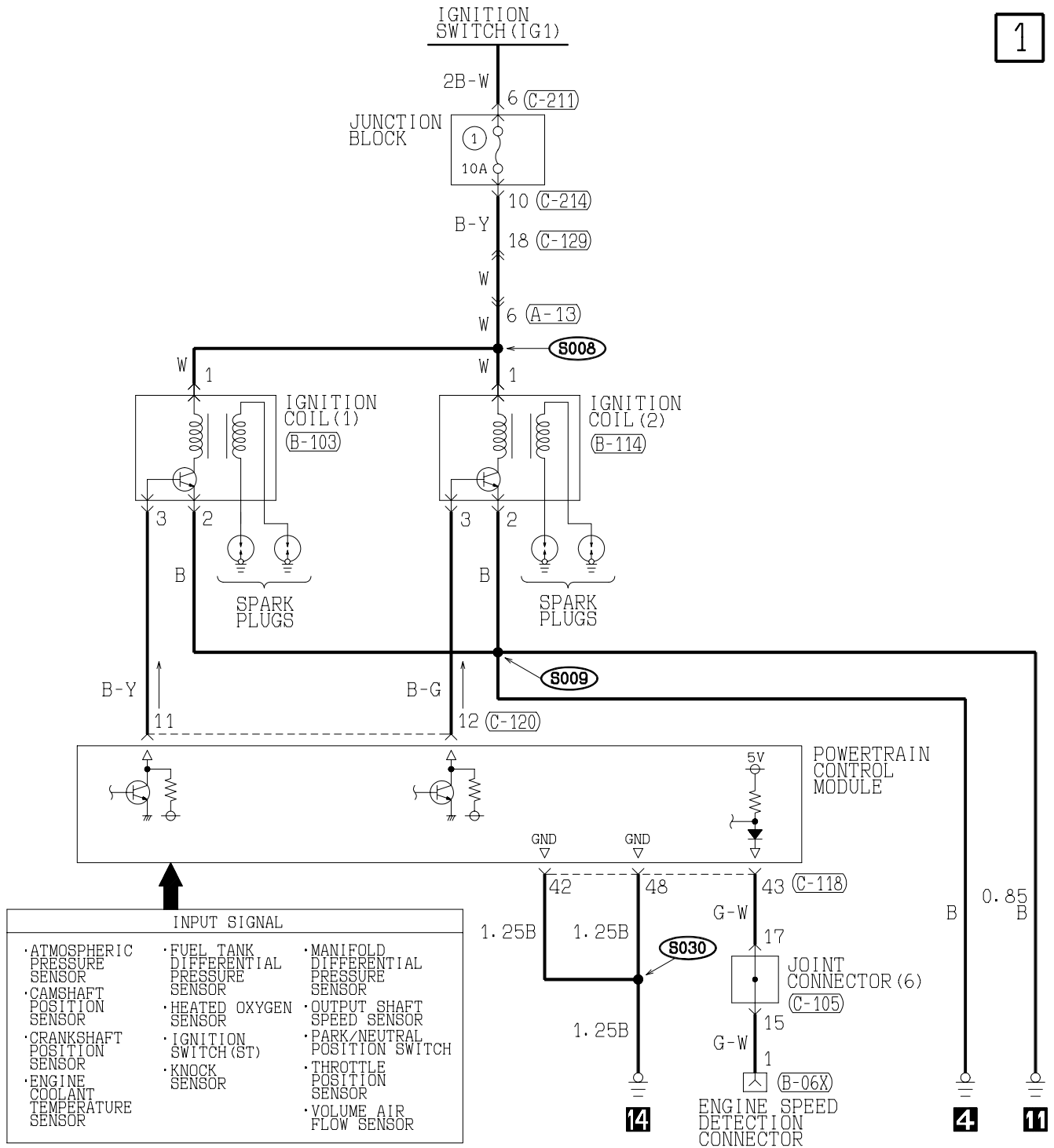

- INPUT SIGNAL**
- ATMOSPHERIC PRESSURE SENSOR
 - FUEL TANK DIFFERENTIAL PRESSURE SENSOR
 - CAMSHAFT POSITION SENSOR
 - CRANKSHAFT POSITION SENSOR
 - ENGINE COOLANT TEMPERATURE SENSOR
 - MANIFOLD DIFFERENTIAL PRESSURE SENSOR
 - HEATED OXYGEN SENSOR
 - IGNITION SWITCH (ST)
 - KNOCK SENSOR
 - OUTPUT SHAFT SPEED SENSOR
 - PARK/NEUTRAL POSITION SWITCH
 - THROTTLE POSITION SENSOR
 - VOLUME AIR FLOW SENSOR

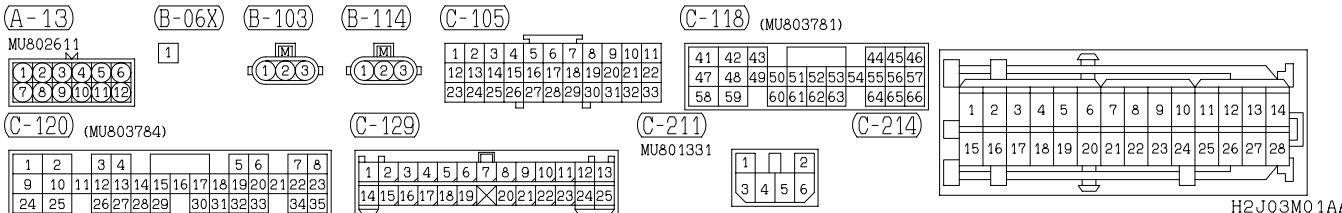

CHARGING SYSTEM <M/T>

M3030000700033

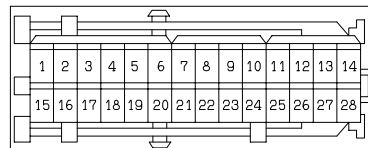
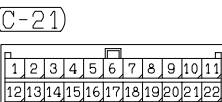
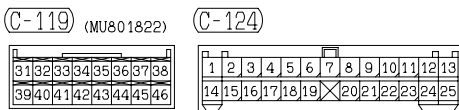
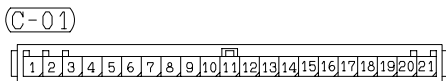
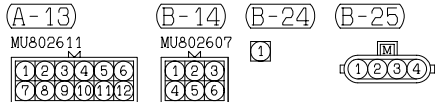
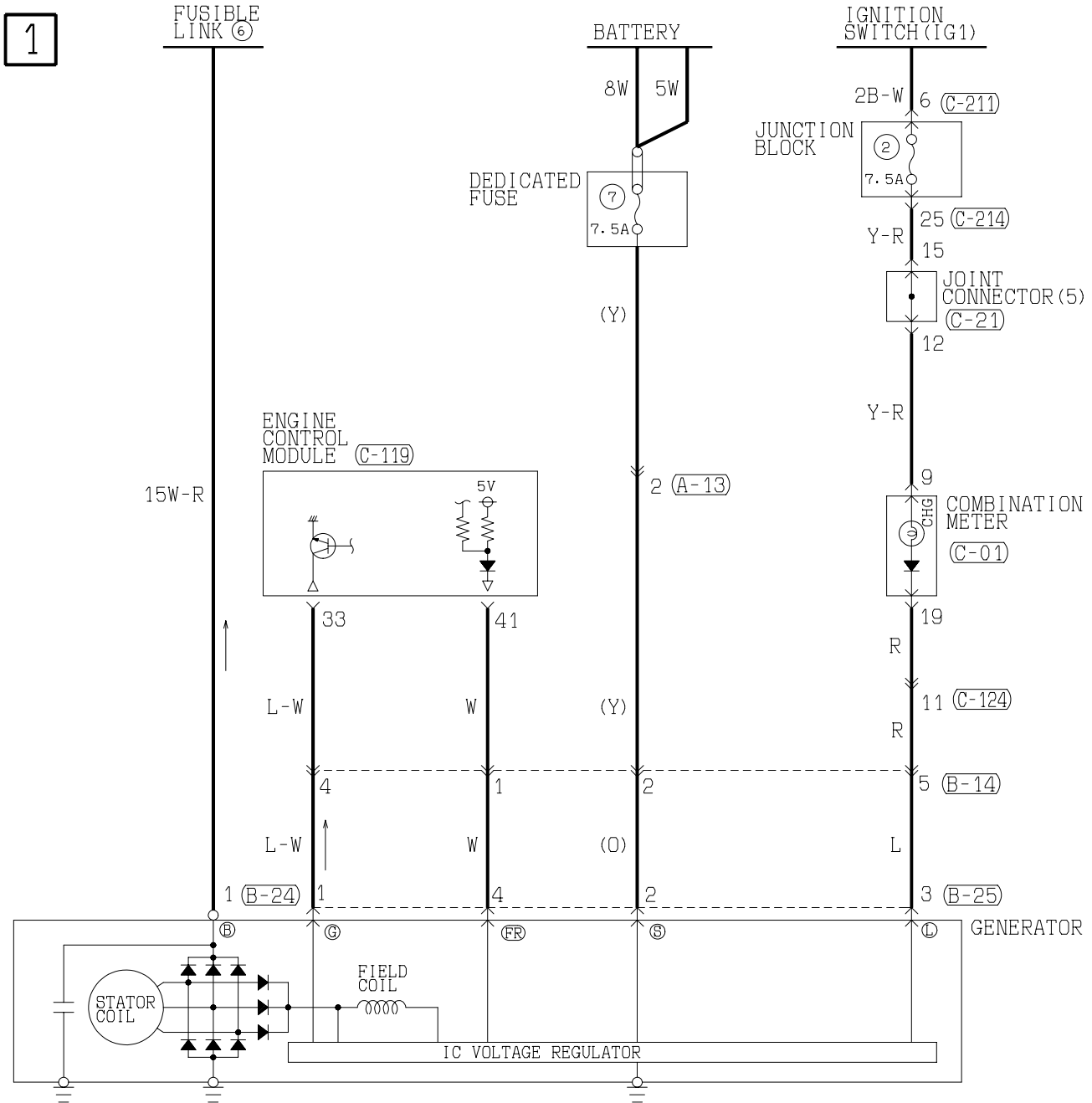

H2J04M00AA

CHARGING SYSTEM <A/T>

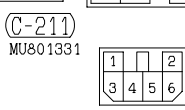
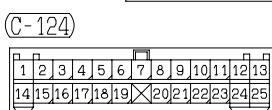
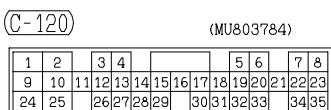
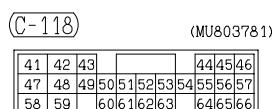
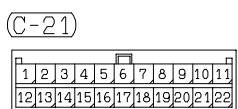
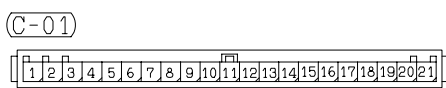
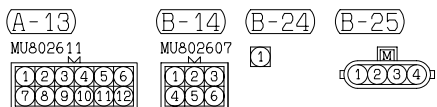
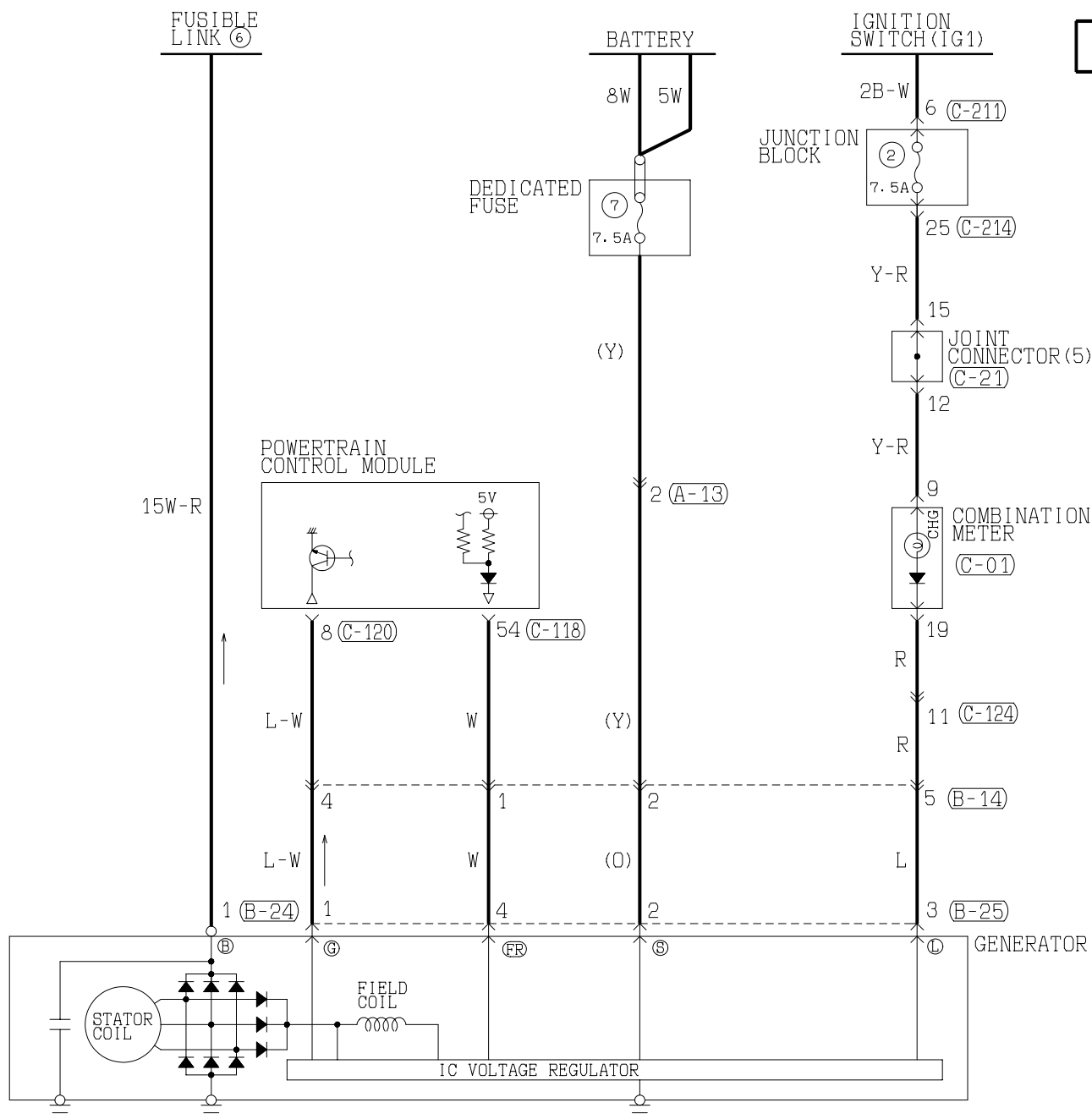

MFI SYSTEM <M/T>

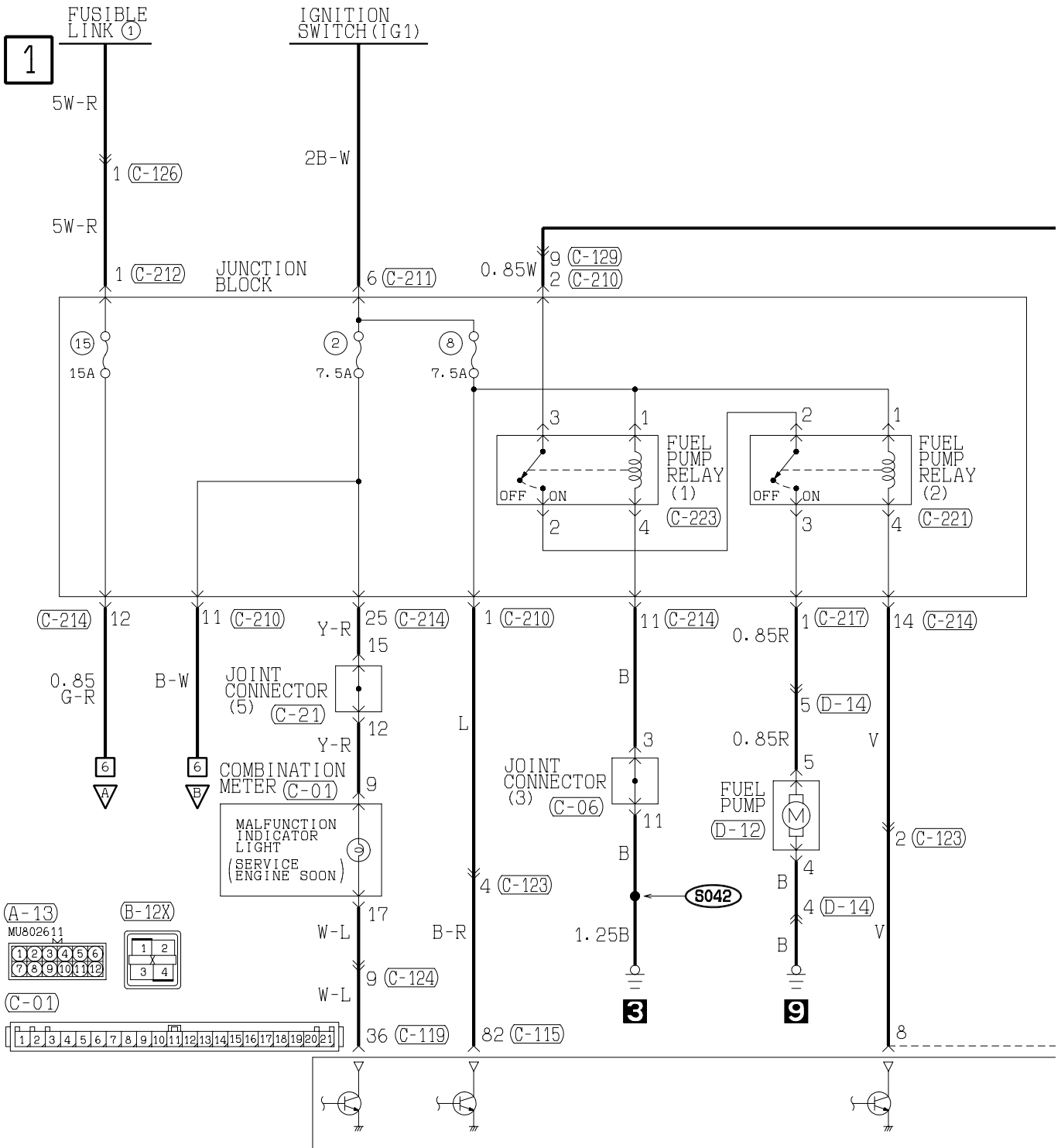

C-05

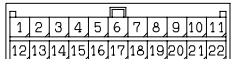

C-06

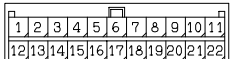

C-21



C-105

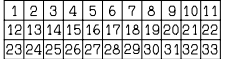

C-124

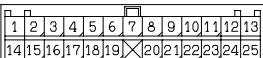

C-126



C-129

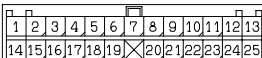

C-210

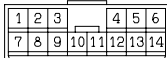

C-211

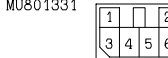

C-212



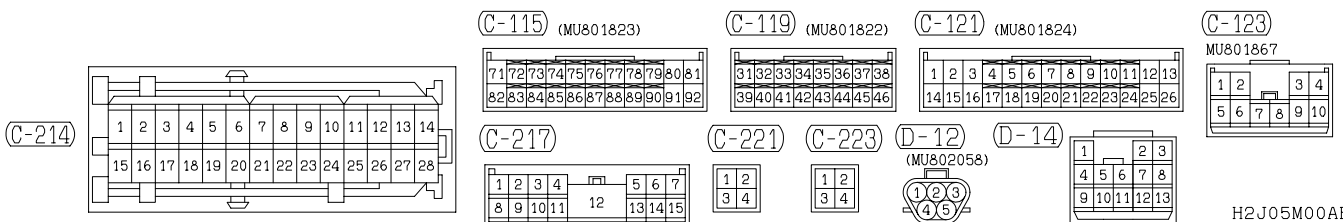
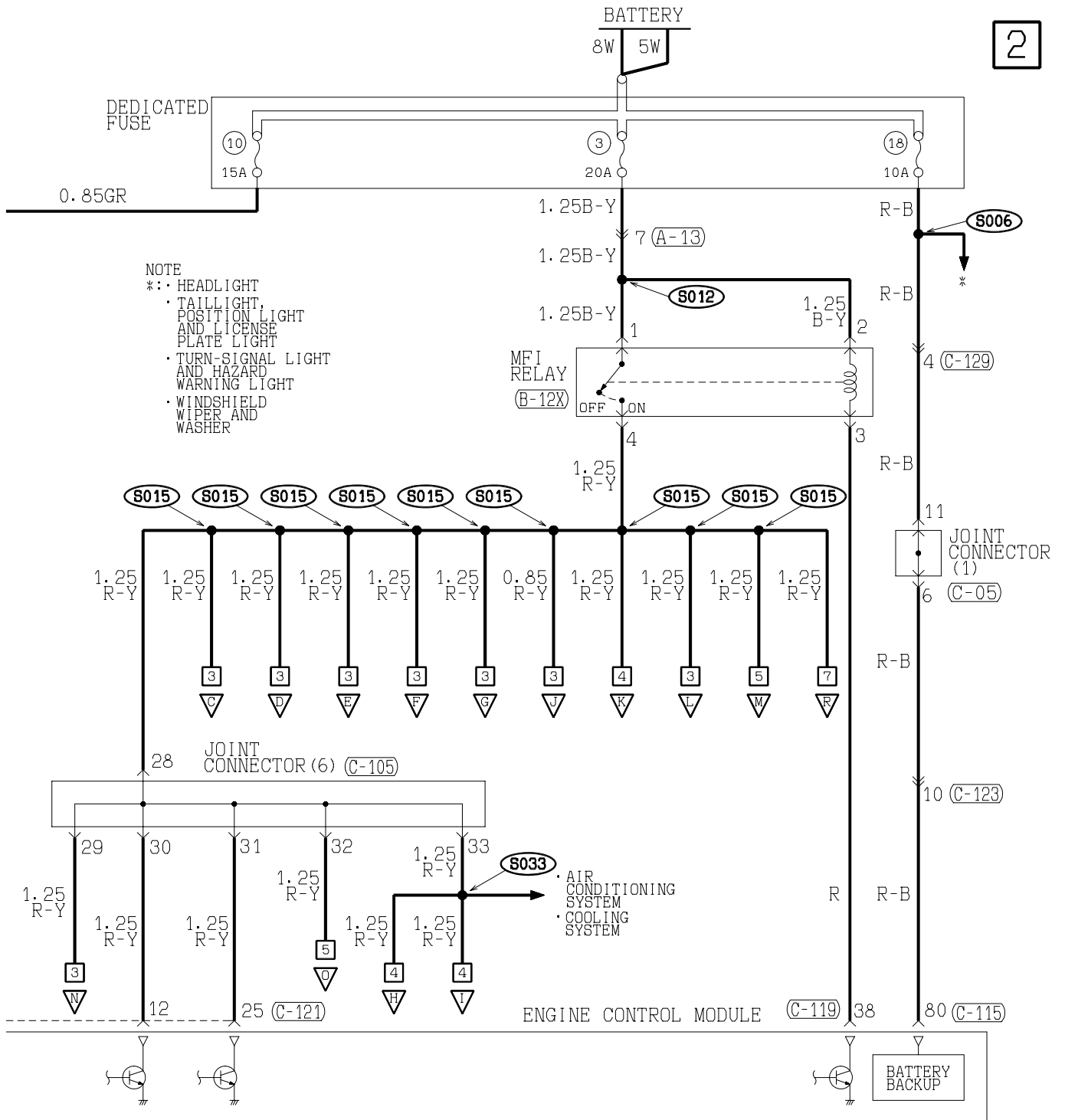

H2J05M00AB

MFI SYSTEM <M/T> (CONTINUED)

3

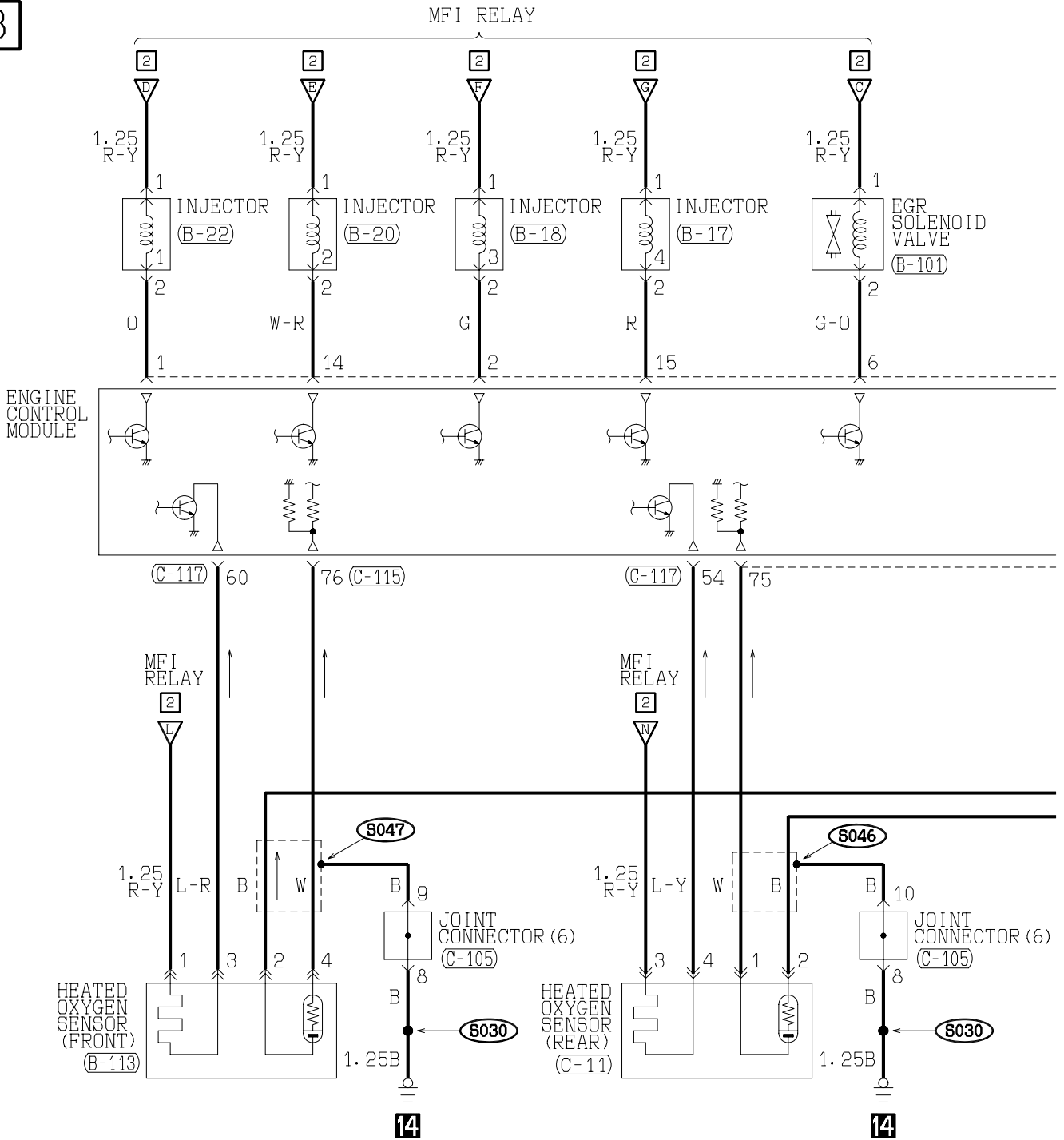

- B-03
(MU802078)
- B-17
- B-18
- B-20
- B-22
- B-101
- B-104
- B-106
MU802337
- B-107
(MU802406)
- B-113
MU802605
- B-117
- B-117-1
- C-11
MU801446

4

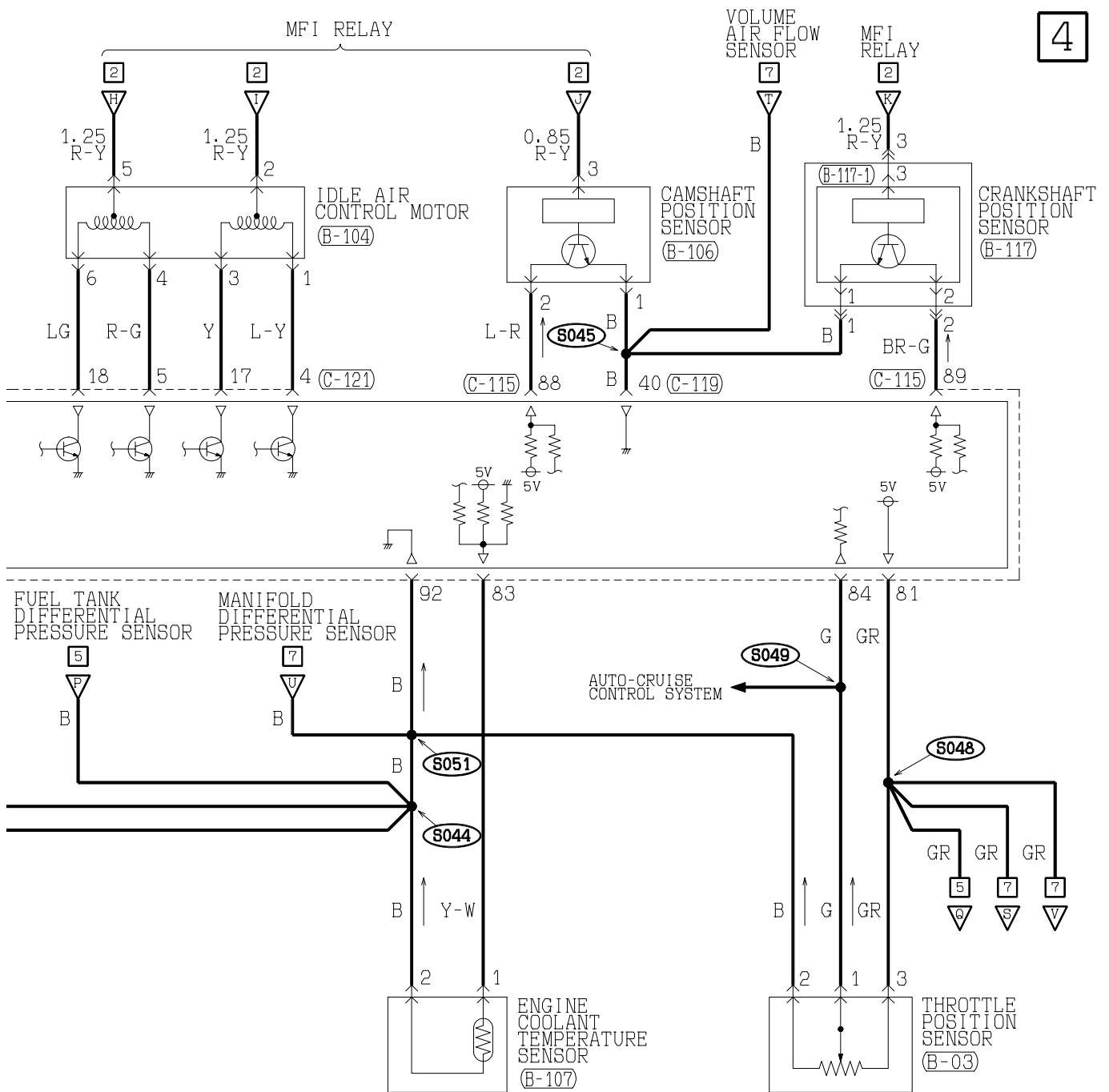

(C-105)

1	2	3	4	5	6	7	8	9	10	11
12	13	14	15	16	17	18	19	20	21	22
23	24	25	26	27	28	29	30	31	32	33

(C-115) (MU801823)

71	72	73	74	75	76	77	78	79	80	81
82	83	84	85	86	87	88	89	90	91	92

(C-117) (MU801820)

51	52	53	54	55	56
57	58	59	60	61	62

(C-119) (MU801822)

31	32	33	34	35	36	37	38
39	40	41	42	43	44	45	46

(C-121) (MU801824)

1	2	3	4	5	6	7	8	9	10	11	12	13
14	15	16	17	18	19	20	21	22	23	24	25	26

WIRE COLOR CODE
 B : BLACK LG : LIGHT GREEN G : GREEN L : BLUE W : WHITE Y : YELLOW SB : SKY BLUE
 BR : BROWN O : ORANGE GR : GRAY R : RED P : PINK V : VIOLET

H2J05M00BB

MFI SYSTEM <M/T> (CONTINUED)

5

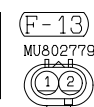
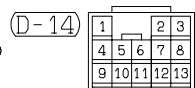
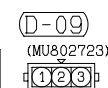
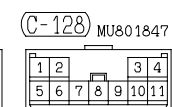
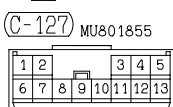
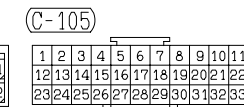
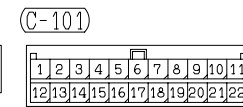
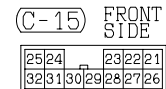
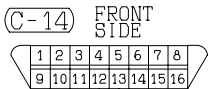
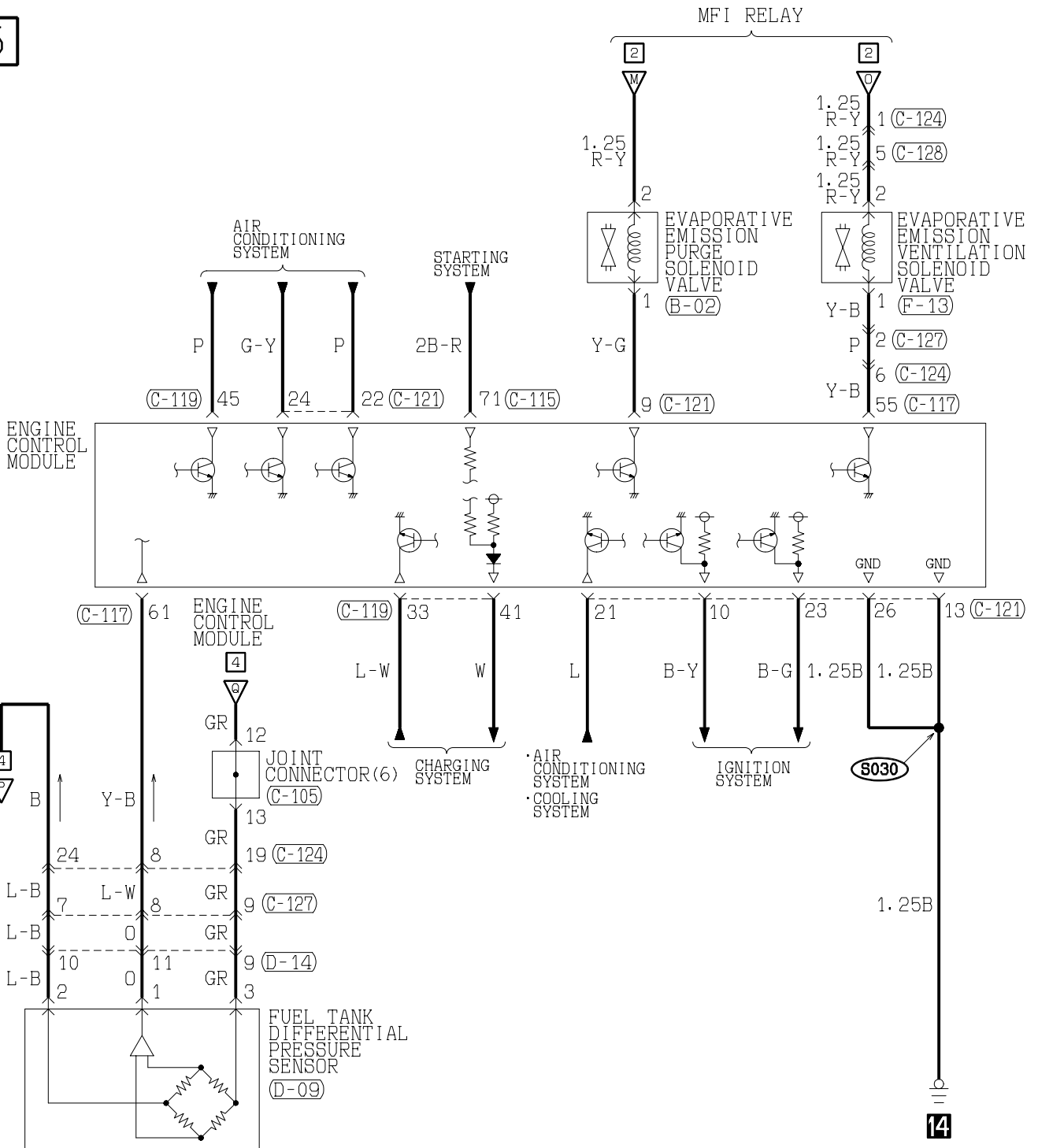

H2J05M00CA

TSB Revision

6

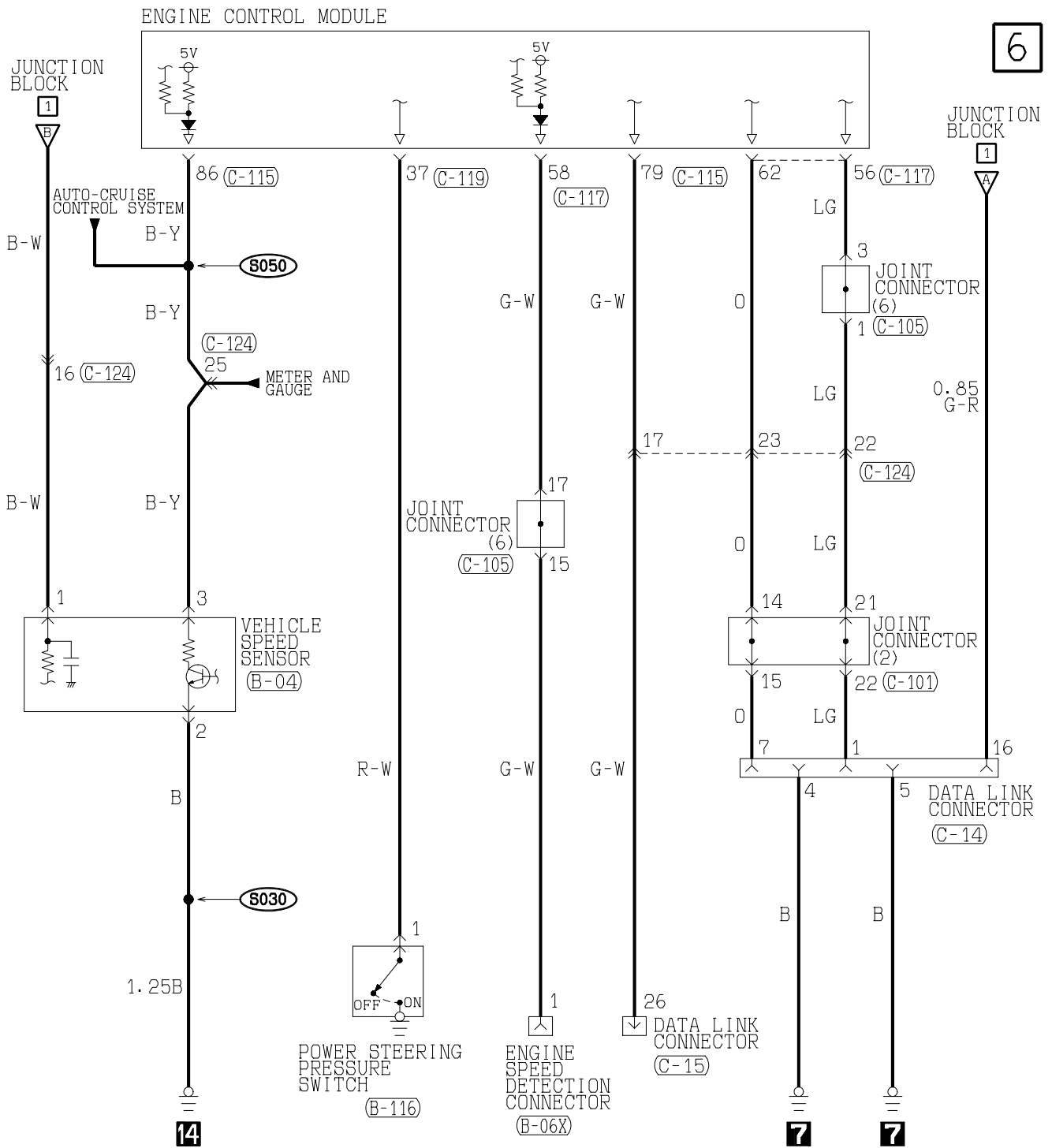

(C-115) (MU801823)

71	72	73	74	75	76	77	78	79	80	81
82	83	84	85	86	87	88	89	90	91	92

(C-117) (MU801820)

51	52	53	54	55	56
57	58	59	60	61	62

(C-119) (MU801822)

31	32	33	34	35	36	37	38
39	40	41	42	43	44	45	46

(C-121) (MU801824)

1	2	3	4	5	6	7	8	9	10	11	12	13
14	15	16	17	18	19	20	21	22	23	24	25	26

(C-124)

1	2	3	4	5	6	7	8	9	10	11	12	13
14	15	16	17	18	19	20	21	22	23	24	25	

WIRE COLOR CODE

B : BLACK LG : LIGHT GREEN G : GREEN L : BLUE W : WHITE Y : YELLOW SB : SKY BLUE
BR : BROWN O : ORANGE GR : GRAY R : RED P : PINK V : VIOLET

H2J05M00CB

MFI SYSTEM <M/T> (CONTINUED)

7

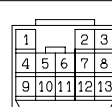
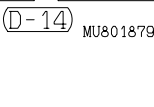
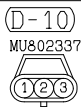
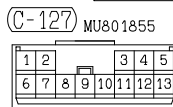
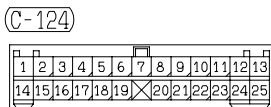
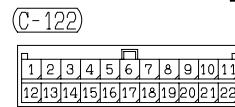
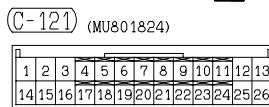
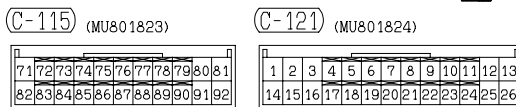
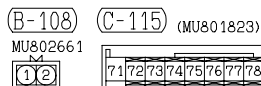
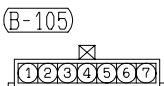
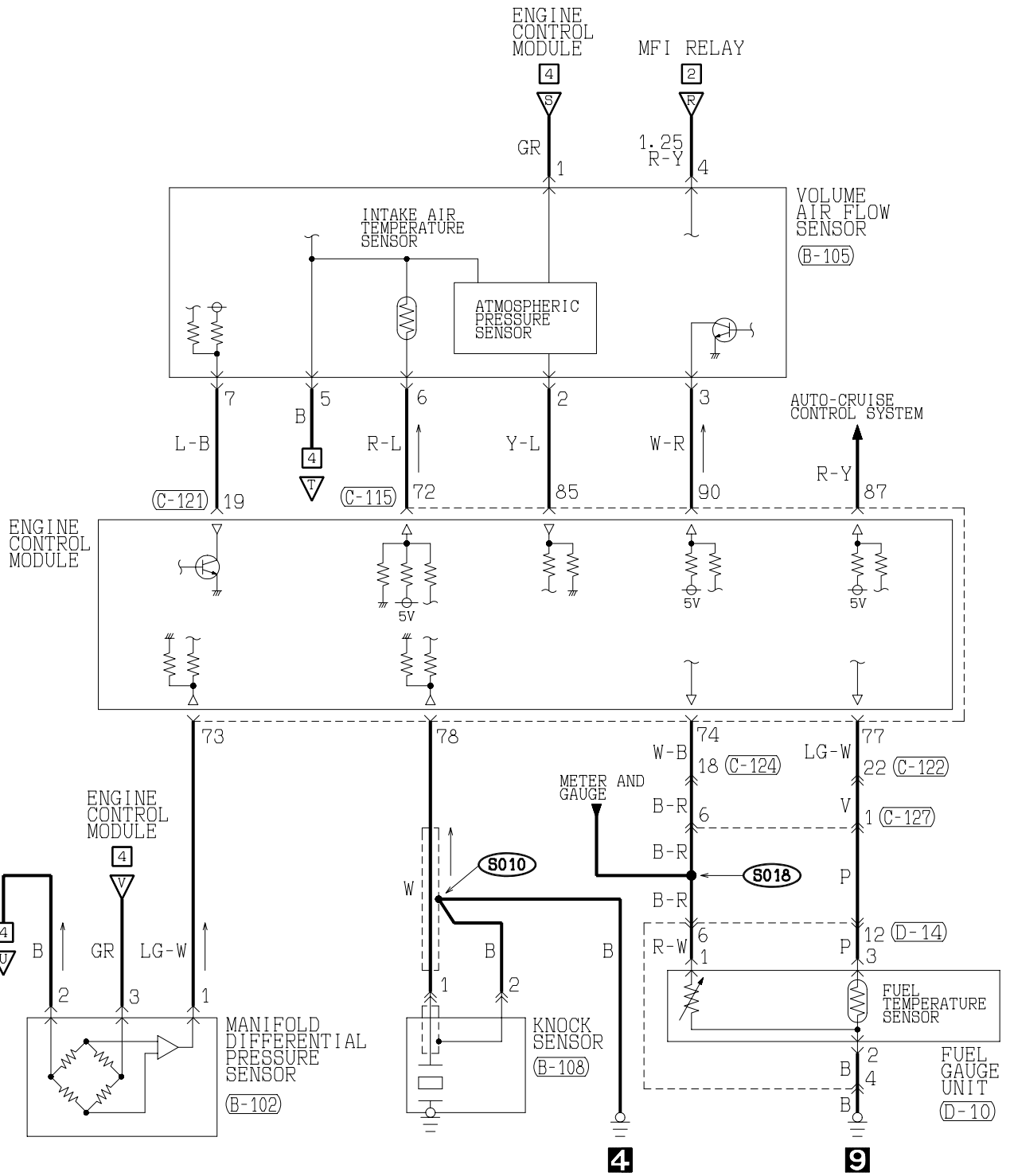

NOTES

MFI SYSTEM <A/T>

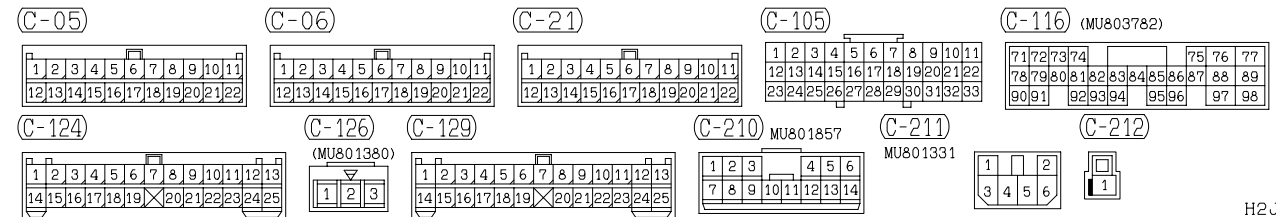
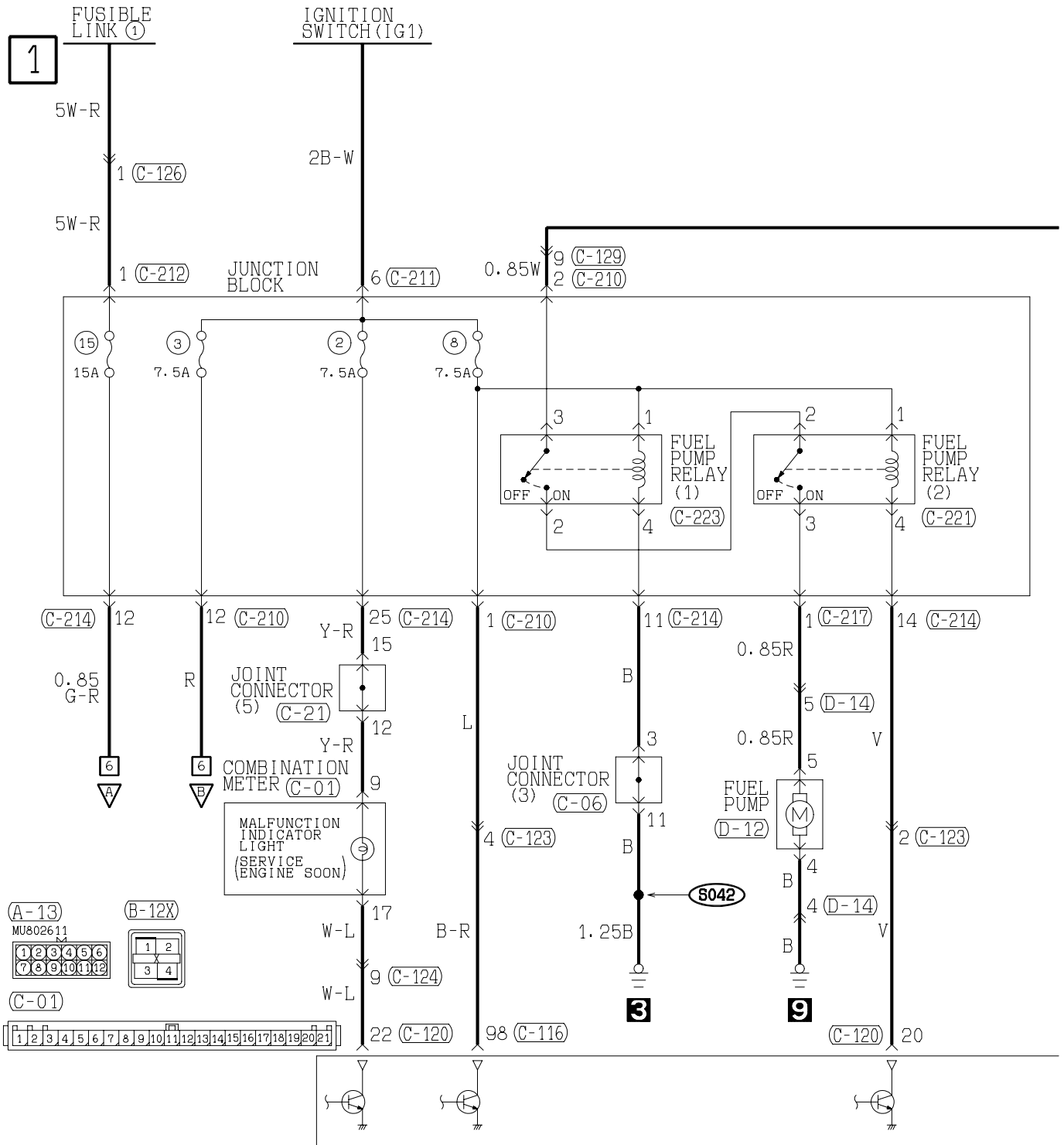

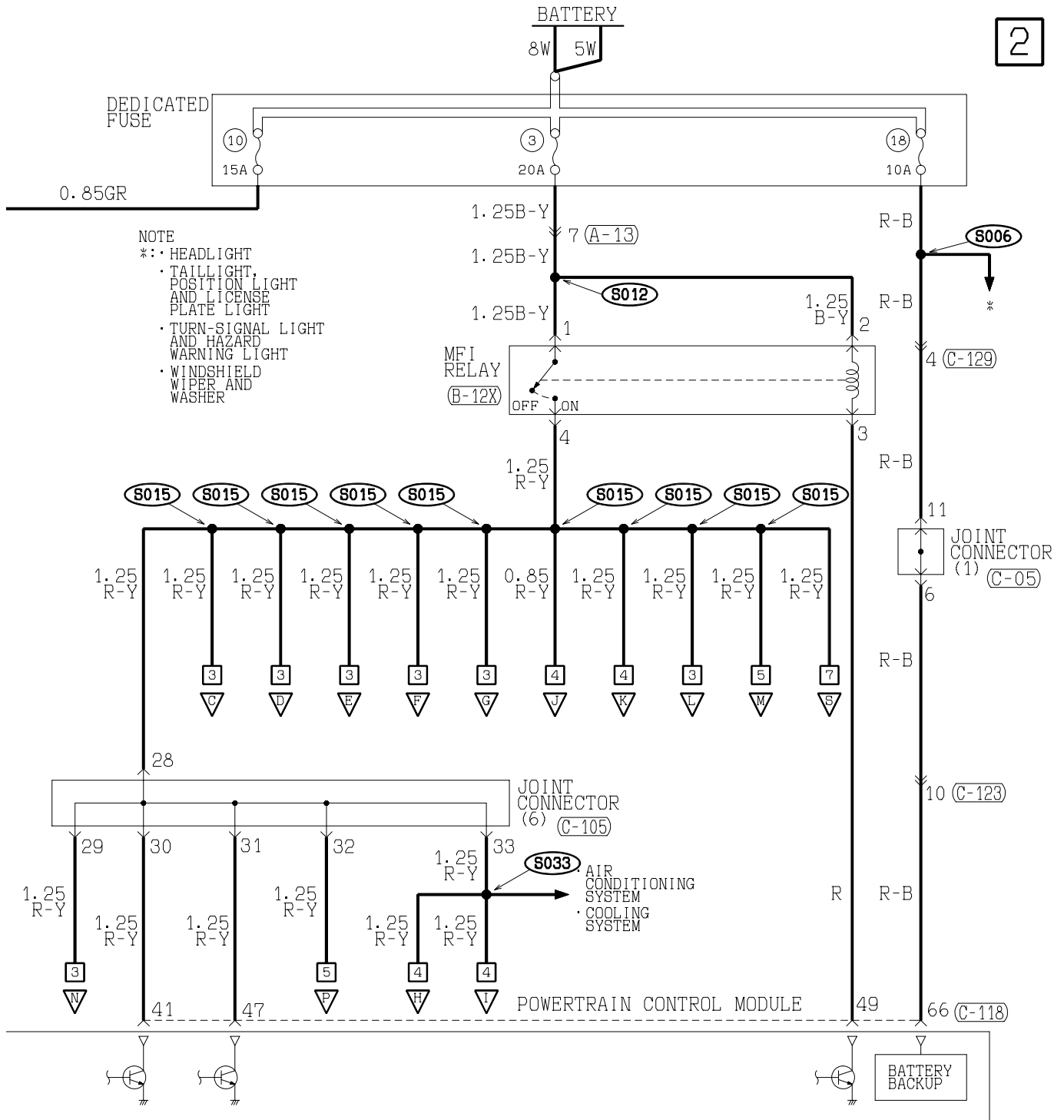

NOTE
* : HEADLIGHT
• TAILLIGHT,
POSITION LIGHT
AND LICENSE
PLATE LIGHT
• TURN-SIGNAL LIGHT
AND HAZARD
WARNING LIGHT
• WINDSHIELD
WIPER AND
WASHER

(C-118) (MU803781)

41	42	43		44	45	46
47	48	49	50	51	52	53
54	55	56	57	58	59	60
61	62	63	64	65	66	

(C-120) (MU803784)

1	2	3	4		5	6	7	8
9	10	11	12	13	14	15	16	17
18	19	20	21	22	23	24	25	26
27	28	29	30	31	32	33	34	35

(C-123)

MU801867

1	2	3	4
5	6	7	8
9	10	11	12
13	14	15	16

(C-214)

1	2	3	4	5	6	7	8	9	10	11	12	13	14
15	16	17	18	19	20	21	22	23	24	25	26	27	28

(C-217)

1	2	3	4		5	6	7
8	9	10	11	12	13	14	15

(C-221)

1	2
3	4

(C-223)

1	2
3	4

(D-12)

(MU802058)

1	2	3
4	5	6

(D-14)

1	2	3
4	5	6
7	8	9
10	11	12
13	14	15

MFI SYSTEM <A/T> (CONTINUED)

3

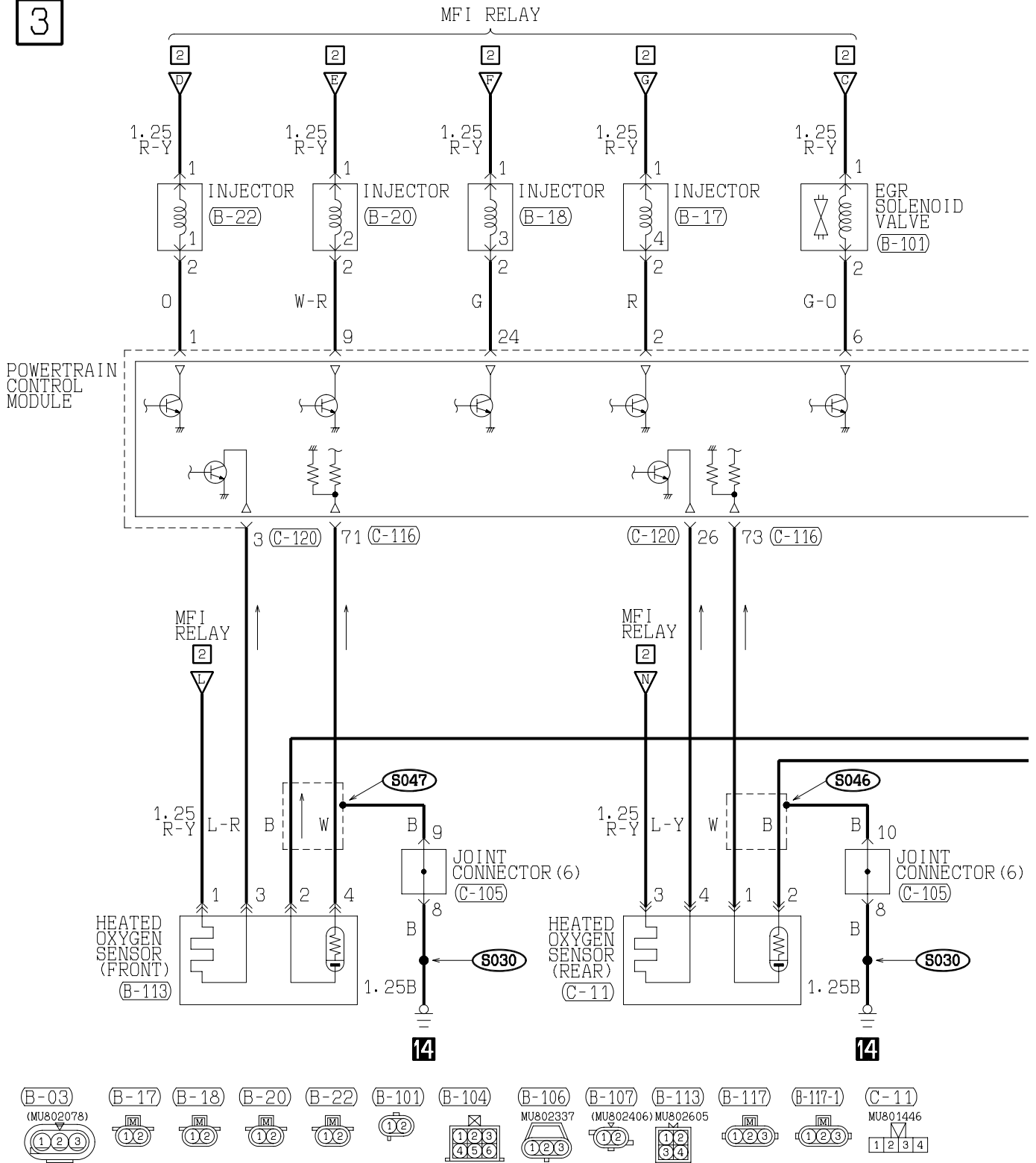

4

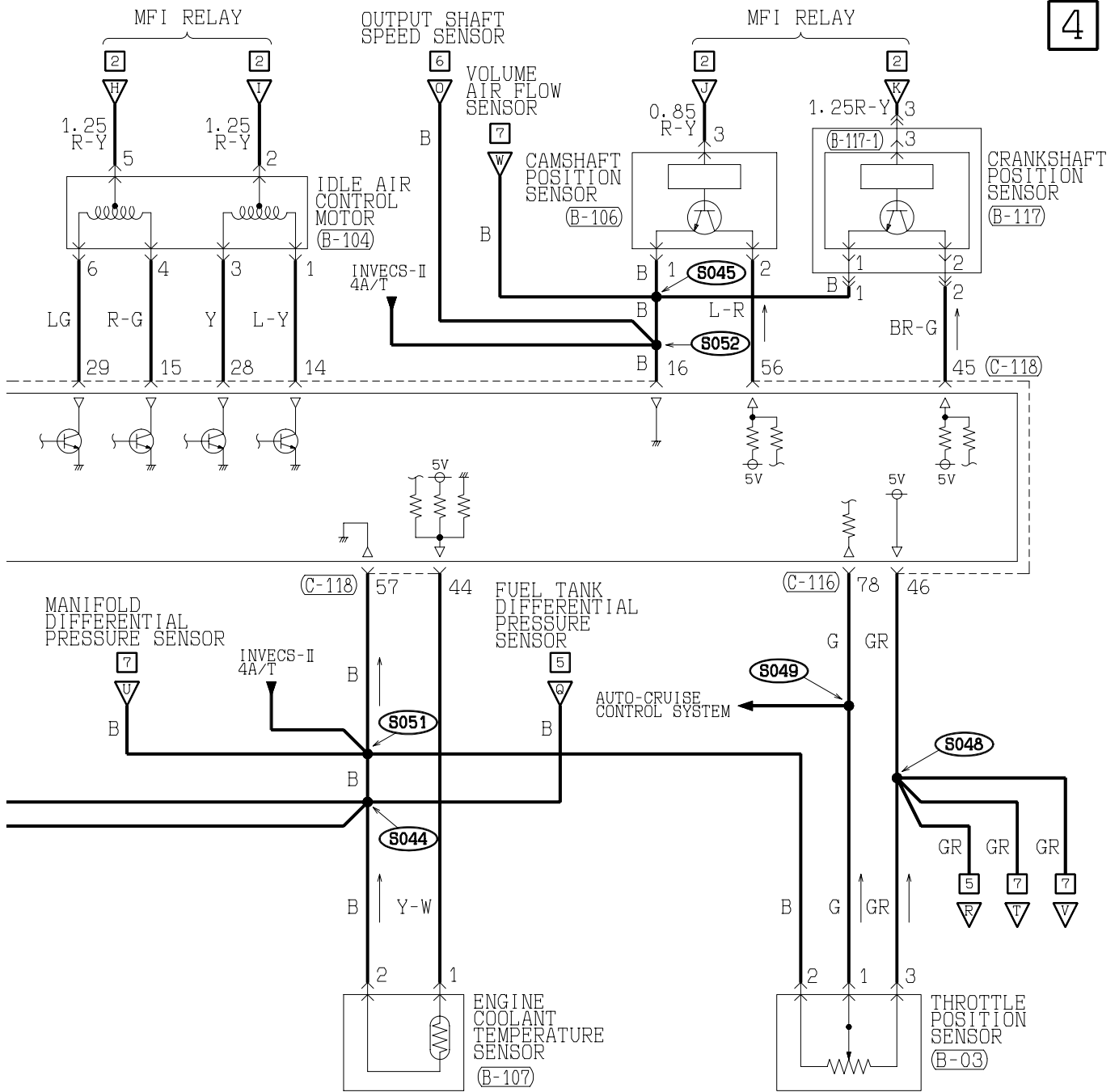

(C-105)

1	2	3	4	5	6	7	8	9	10	11
12	13	14	15	16	17	18	19	20	21	22
23	24	25	26	27	28	29	30	31	32	33

(C-116) (MU803782)

71	72	73	74	75	76	77					
78	79	80	81	82	83	84	85	86	87	88	89
90	91	92	93	94	95	96	97	98			

(C-118) (MU803781)

41	42	43	44	45	46					
47	48	49	50	51	52	53	54	55	56	57
58	59	60	61	62	63	64	65	66		

(C-120) (MU803784)

1	2	3	4	5	6	7	8							
9	10	11	12	13	14	15	16	17	18	19	20	21	22	23
24	25	26	27	28	29	30	31	32	33	34	35			

WIRE COLOR CODE
 B : BLACK LG : LIGHT GREEN G : GREEN L : BLUE W : WHITE Y : YELLOW SB : SKY BLUE
 BR : BROWN O : ORANGE GR : GRAY R : RED P : PINK V : VIOLET

H2J05M01BB

MFI SYSTEM <A/T> (CONTINUED)

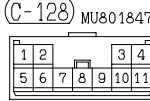
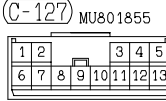
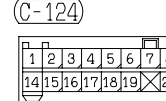
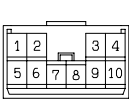
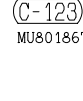
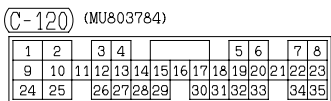
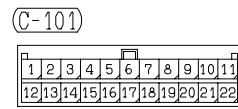
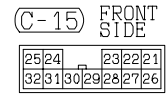
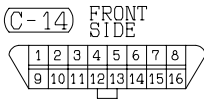
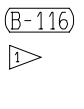
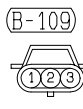
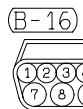
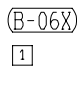
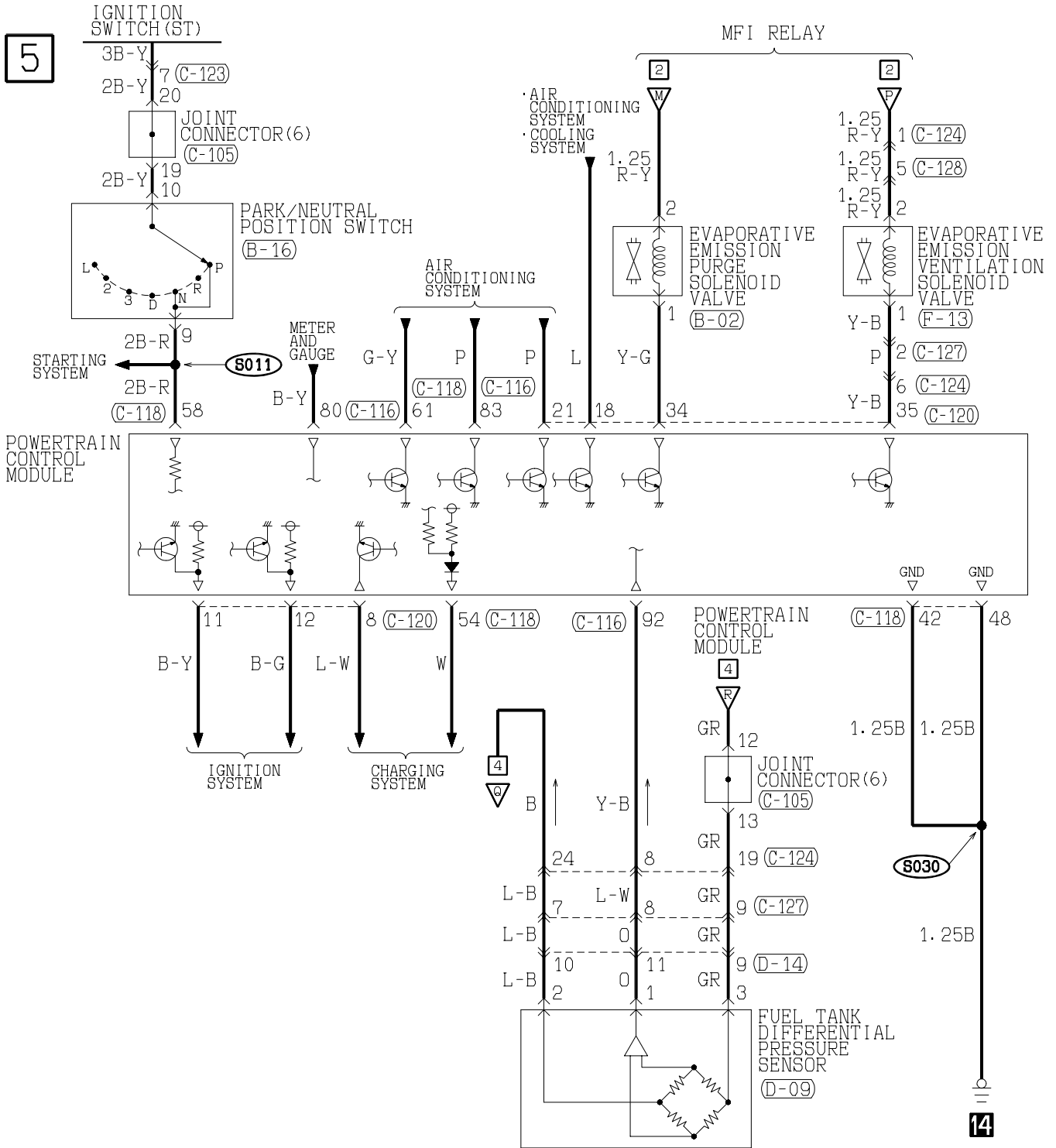

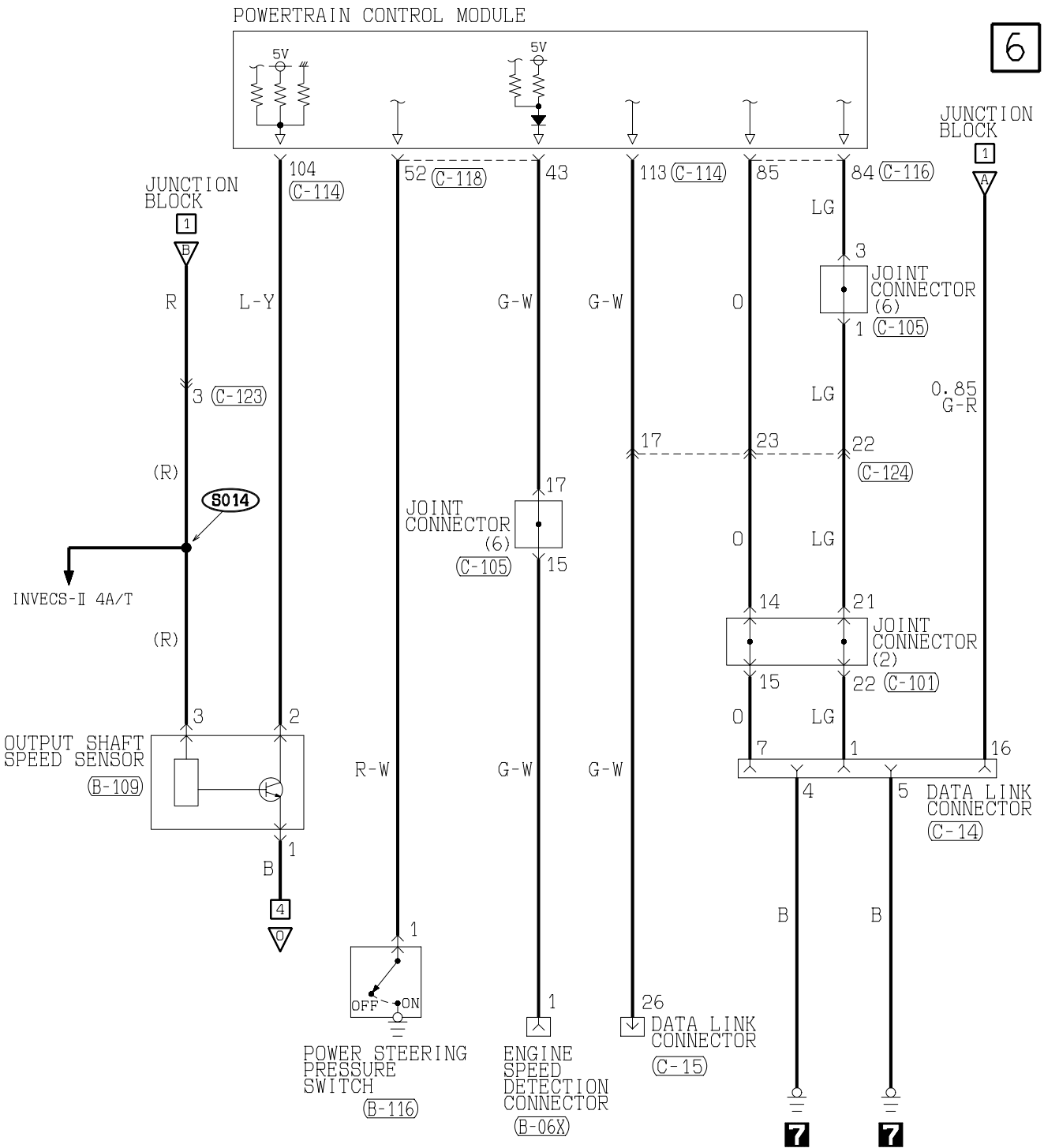

(C-105)

1	2	3	4	5	6	7	8	9	10	11
12	13	14	15	16	17	18	19	20	21	22
23	24	25	26	27	28	29	30	31	32	33

(C-114) (MU803783)

101	102	103	104	105	106	107
108	109	110	111	112	113	114
115	116	117	118	119	120	121
122	123	124	125	126	127	128
129	130					

(C-116) (MU803782)

71	72	73	74	75	76	77
78	79	80	81	82	83	84
85	86	87	88	89	90	91
92	93	94	95	96	97	98

(C-118) (MU803781)

41	42	43	44	45	46
47	48	49	50	51	52
53	54	55	56	57	58
59	60	61	62	63	64
65	66				

(D-09) (MU802723)

1	2	3
---	---	---

(D-14)

1	2	3
4	5	6
7	8	9
10	11	12
13		

(F-13) MU802779

1	2
---	---

WIRE COLOR CODE

B : BLACK LG : LIGHT GREEN G : GREEN L : BLUE

BR : BROWN O : ORANGE GR : GRAY R : RED

W : WHITE SB : SKY BLUE P : PINK Y : YELLOW

V : VIOLET

MFI SYSTEM <A/T> (CONTINUED)

7

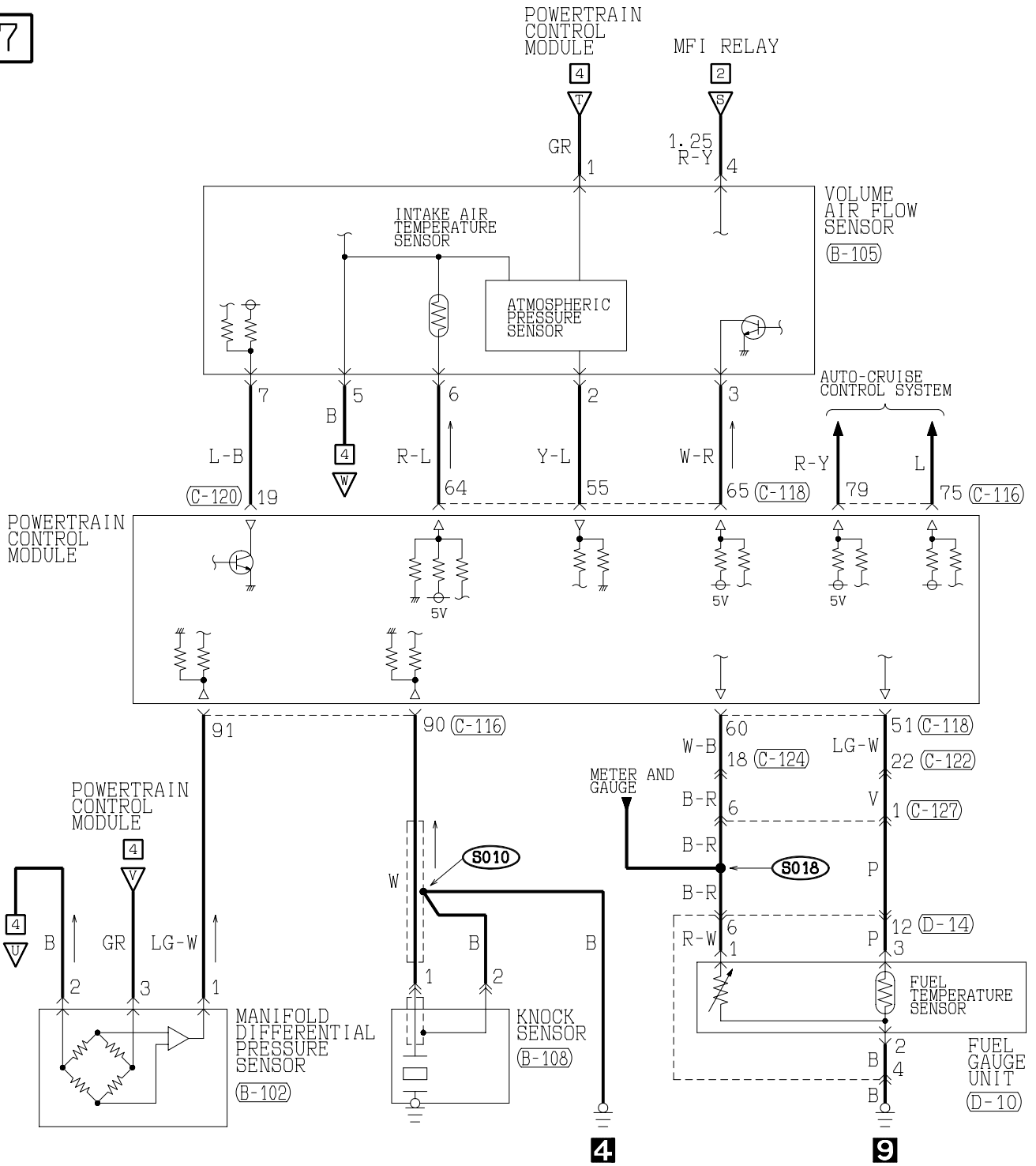

(B-102) (MU802723)	(B-105)	(B-108) MU802661	(C-116) (MU803782)	(C-118) (MU803781)	(C-120) (MU803784)
1 2 3	1 2 3 4 5 6 7	1 2	71 72 73 74 75 76 77 78 79 80 81 82 83 84 85 86 87 88 89 90 91 92 93 94 95 96 97 98	41 42 43 44 45 46 47 48 49 50 51 52 53 54 55 56 57 58 59 60 61 62 63 64 65 66	1 2 3 4 5 6 7 8 9 10 11 12 13 14 15 16 17 18 19 20 21 22 23 24 25 26 27 28 29 30 31 32 33 34 35
(C-122)	(C-124)	(C-127) MU801855	(D-10) MU802337	(D-14) MU801879	
1 2 3 4 5 6 7 8 9 10 11 12 13 14 15 16 17 18 19 20 21 22	1 2 3 4 5 6 7 8 9 10 11 12 13 14 15 16 17 18 19 20 21 22 23 24 25	1 2 3 4 5 6 7 8 9 10 11 12 13	1 2 3 4 5 6	1 2 3 4 5 6 7 8 9 10 11 12 13	

COOLING SYSTEM

M3030001000037

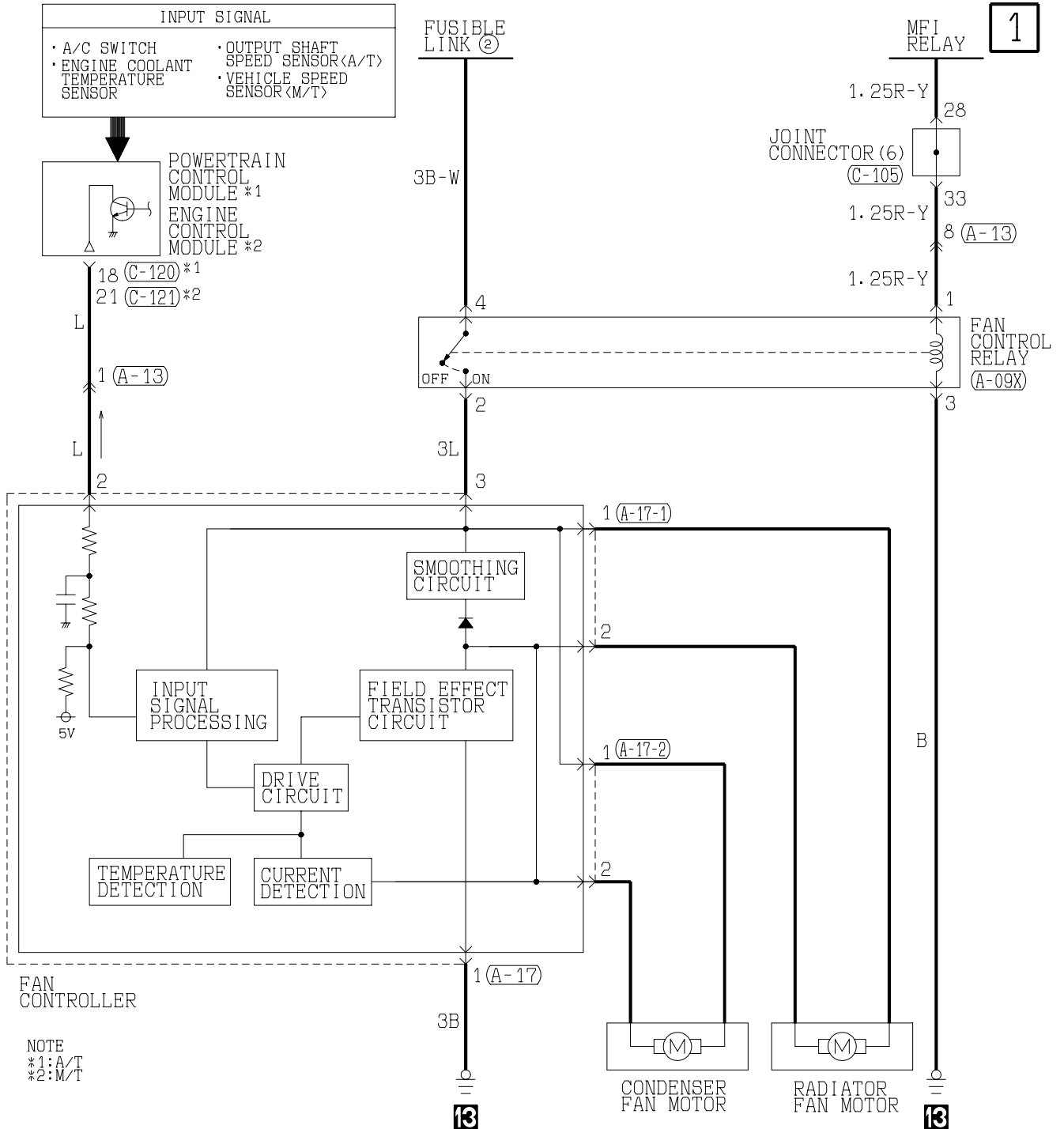

NOTE
*1: A/T
*2: M/T

(A-09X)	(A-13) MU802611	(A-17) (MU802322)	(A-17-1)	(A-17-2)	(C-105)	(C-120) (MU803784)
(C-121) (MU801824)	WIRE COLOR CODE B : BLACK LG : LIGHT GREEN G : GREEN L : BLUE BR : BROWN O : ORANGE GR : GRAY R : RED W : WHITE SB : SKY BLUE P : PINK Y : YELLOW V : VIOLET					

H2J06M00AA

INVECS-II 4A/T

1

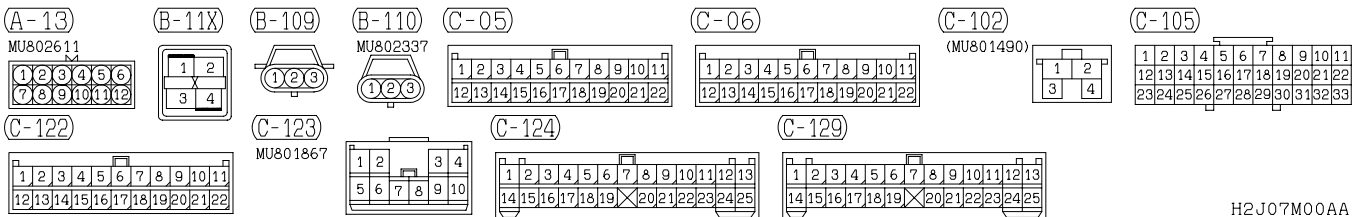
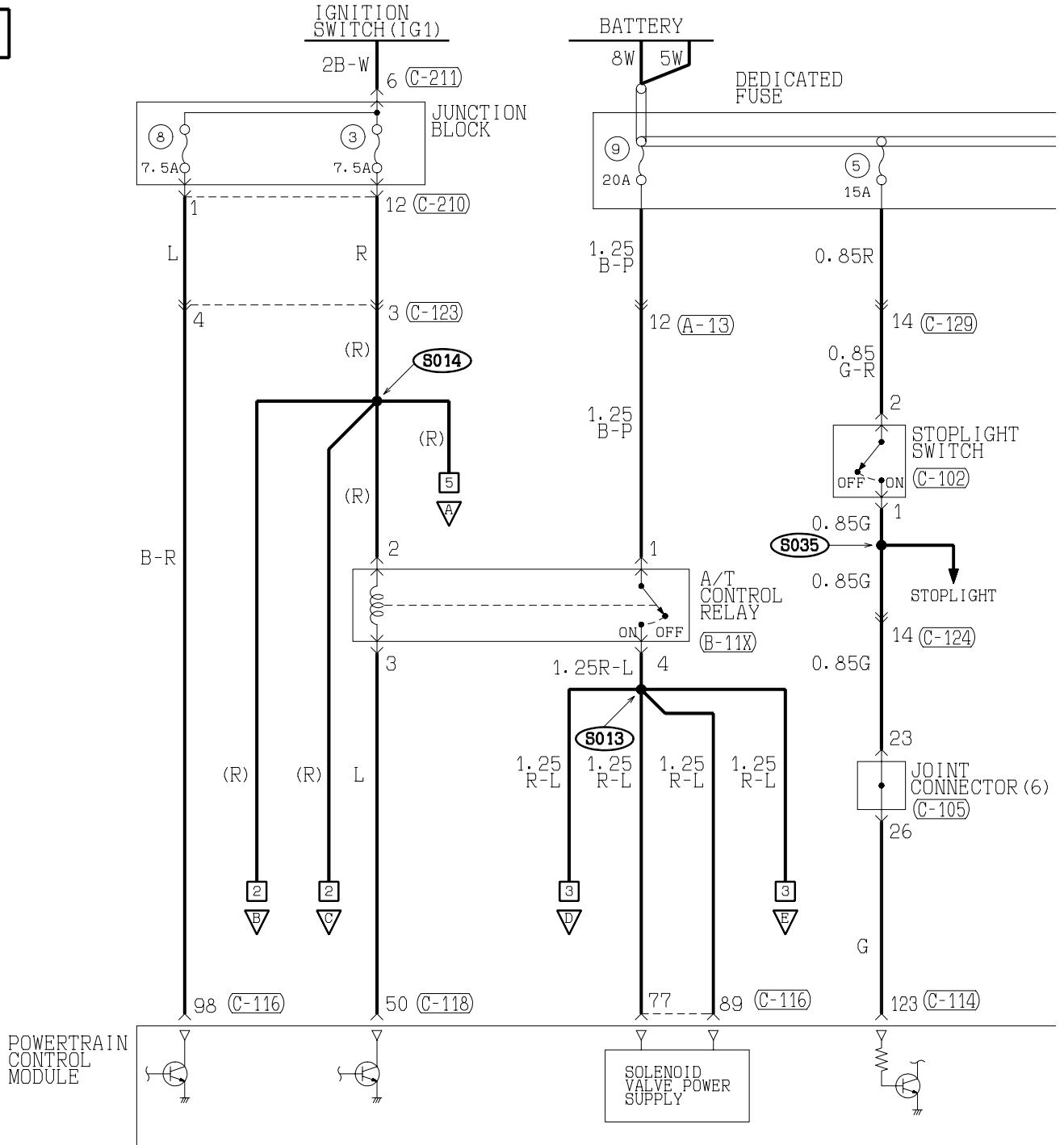

2

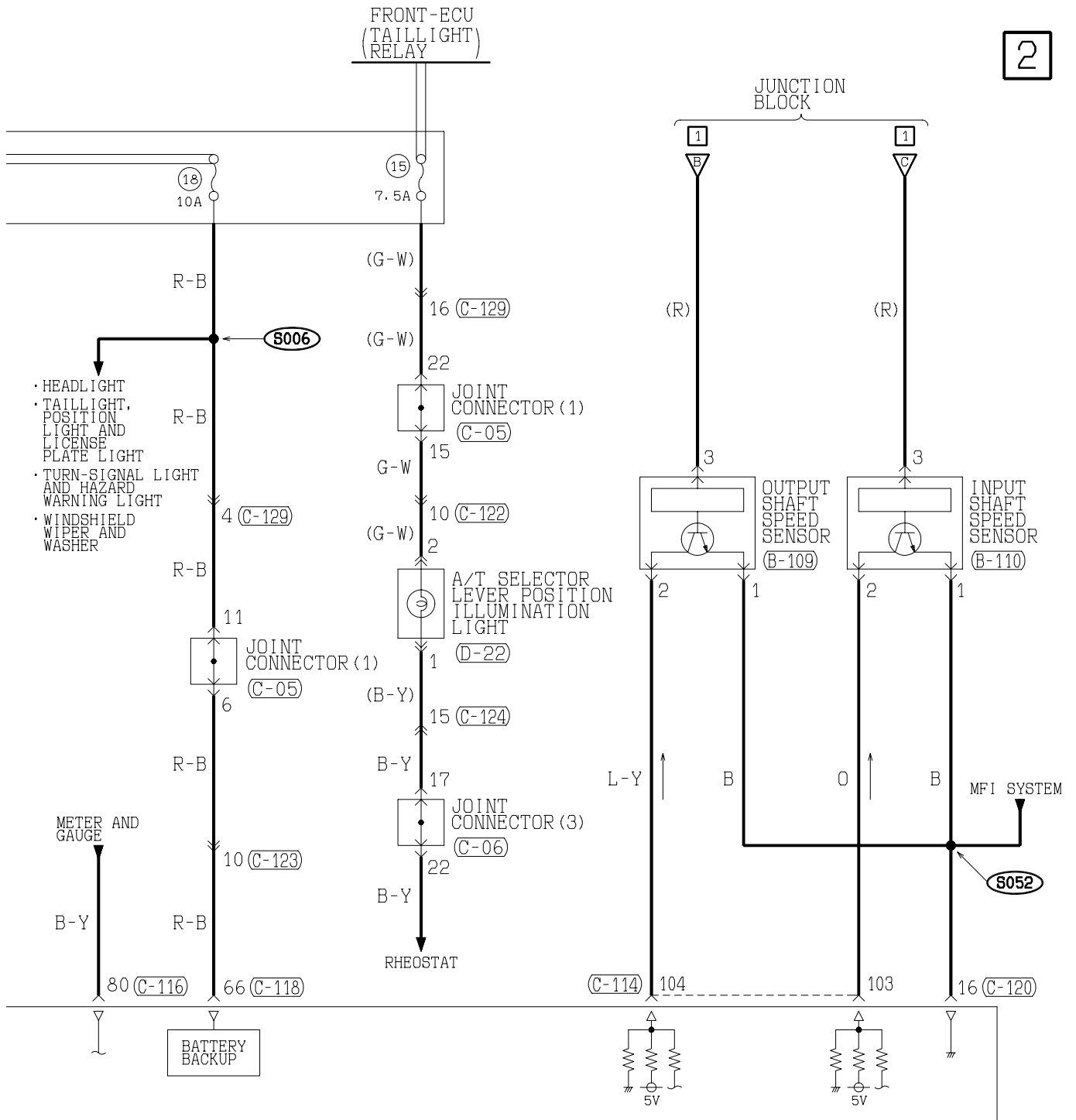

(C-114) (MU803783)

101	102	103	104	105	106	107
108	109	110	111	112	113	114
115	116	117	118	119	120	121
122	123	124	125	126	127	128
129	130					

(C-116) (MU803782)

71	72	73	74	75	76	77
78	79	80	81	82	83	84
85	86	87	88	89	90	91
92	93	94	95	96	97	98

(C-118) (MU803781)

41	42	43	44	45	46
47	48	49	50	51	52
53	54	55	56	57	58
59	60	61	62	63	64
65	66				

(C-120) (MU803784)

1	2	3	4	5	6	7	8
9	10	11	12	13	14	15	16
17	18	19	20	21	22	23	24
25	26	27	28	29	30	31	32
33	34	35					

(C-210) MU801857

1	2	3	4	5	6
7	8	9	10	11	12
13	14				

(C-211) MU801331

1	2
3	4
5	6

(D-22) MU801441

1	2
---	---

WIRE COLOR CODE
 B : BLACK LG : LIGHT GREEN
 BR : BROWN O : ORANGE
 W : WHITE SB : SKY BLUE
 V : VIOLET

G : GREEN L : BLUE
 GR : GRAY R : RED
 P : PINK Y : YELLOW

H2J07M00AB

INVECS-II 4A/T (CONTINUED)

3

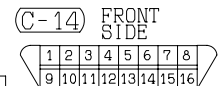
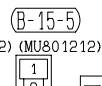
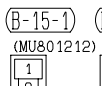
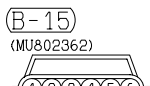
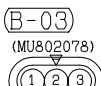
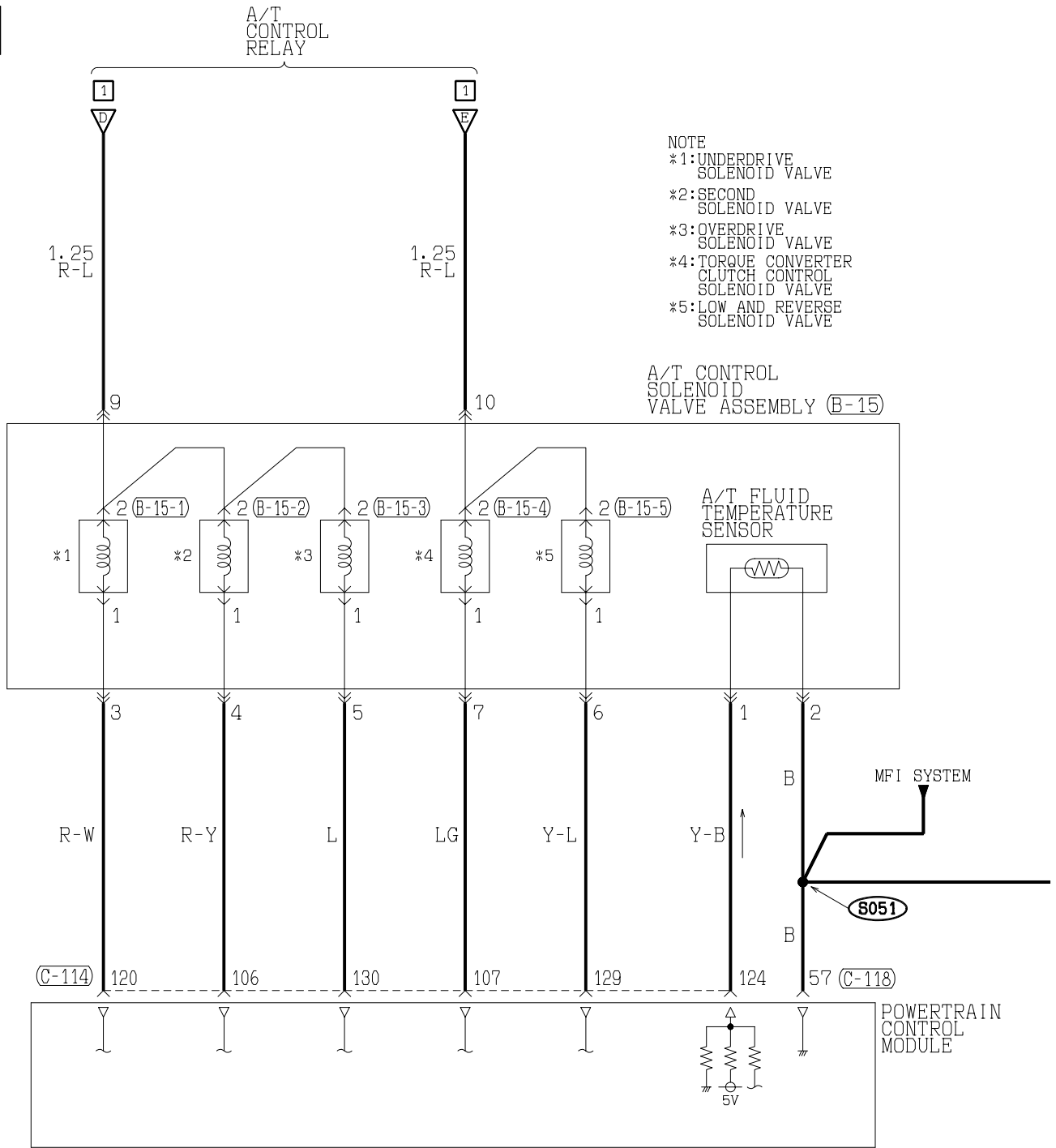

C-124

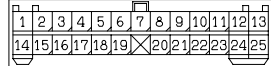

C-126

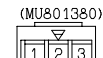

C-212



C-214

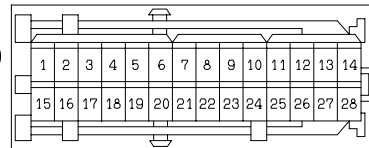

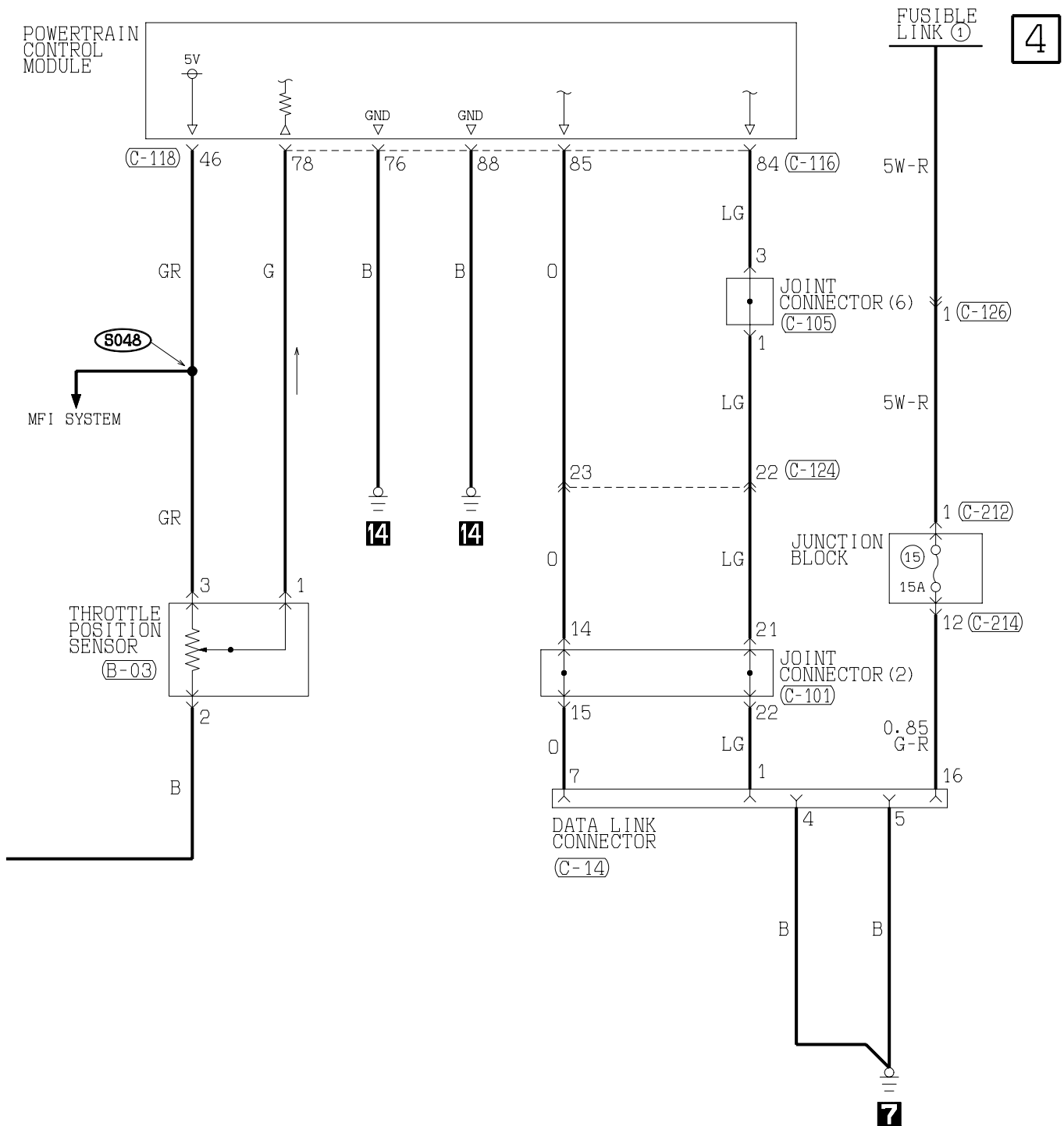

(C-101)

1	2	3	4	5	6	7	8	9	10	11
12	13	14	15	16	17	18	19	20	21	22
12	13	14	15	16	17	18	19	20	21	22
12	13	14	15	16	17	18	19	20	21	22

(C-105)

1	2	3	4	5	6	7	8	9	10	11
12	13	14	15	16	17	18	19	20	21	22
23	24	25	26	27	28	29	30	31	32	33

(C-114) (MU803783)

101	102	103	104	105	106	107
108	109	110	111	112	113	114
115	116	117	118	119	120	
121	122	123	124	125	126	127
128	129	130				

(C-116) (MU803782)

71	72	73	74	75	76	77
78	79	80	81	82	83	84
85	86	87	88	89		
90	91	92	93	94	95	96
97	98					

(C-118) (MU803781)

41	42	43	44	45	46
47	48	49	50	51	52
53	54	55	56	57	
58	59	60	61	62	63
64	65	66			

WIRE COLOR CODE
 B : BLACK LG : LIGHT GREEN G : GREEN L : BLUE W : WHITE Y : YELLOW SB : SKY BLUE
 BR : BROWN O : ORANGE GR : GRAY R : RED P : PINK V : VIOLET

H2J07M00BB

INVECS-II 4A/T (CONTINUED)

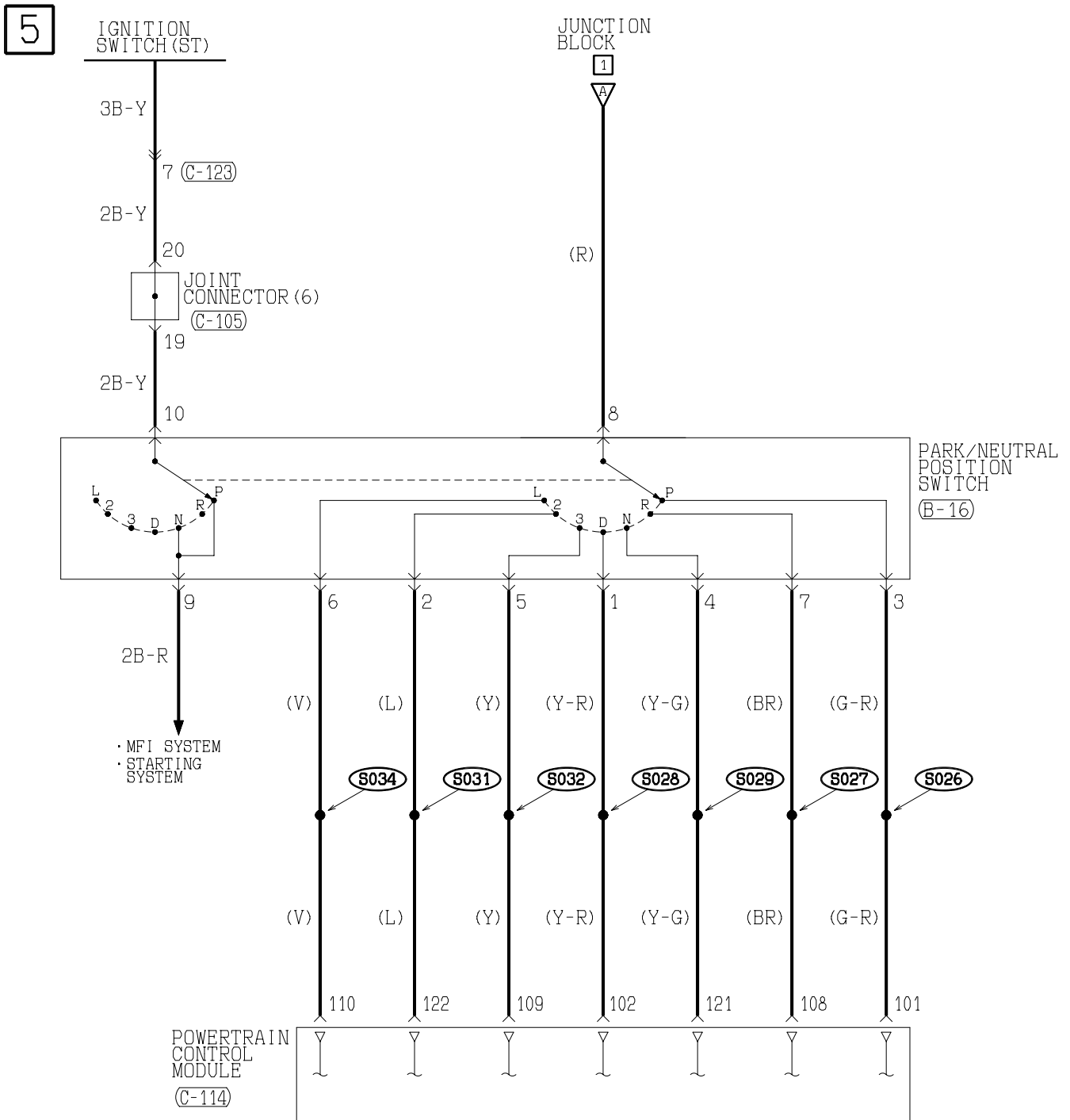

(B-16) MU802355

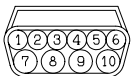

(C-105)

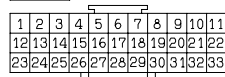

(C-114) (MU8037&3)

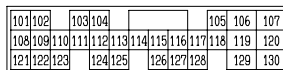

(C-123)

MU801867

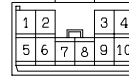

WIRE COLOR CODE

B : BLACK LG: LIGHT GREEN G : GREEN L : BLUE W : WHITE Y : YELLOW SB: SKY BLUE
BR: BROWN O : ORANGE GR: GRAY R : RED P : PINK V : VIOLET

NOTES

HEADLIGHT

M3030001500021

1

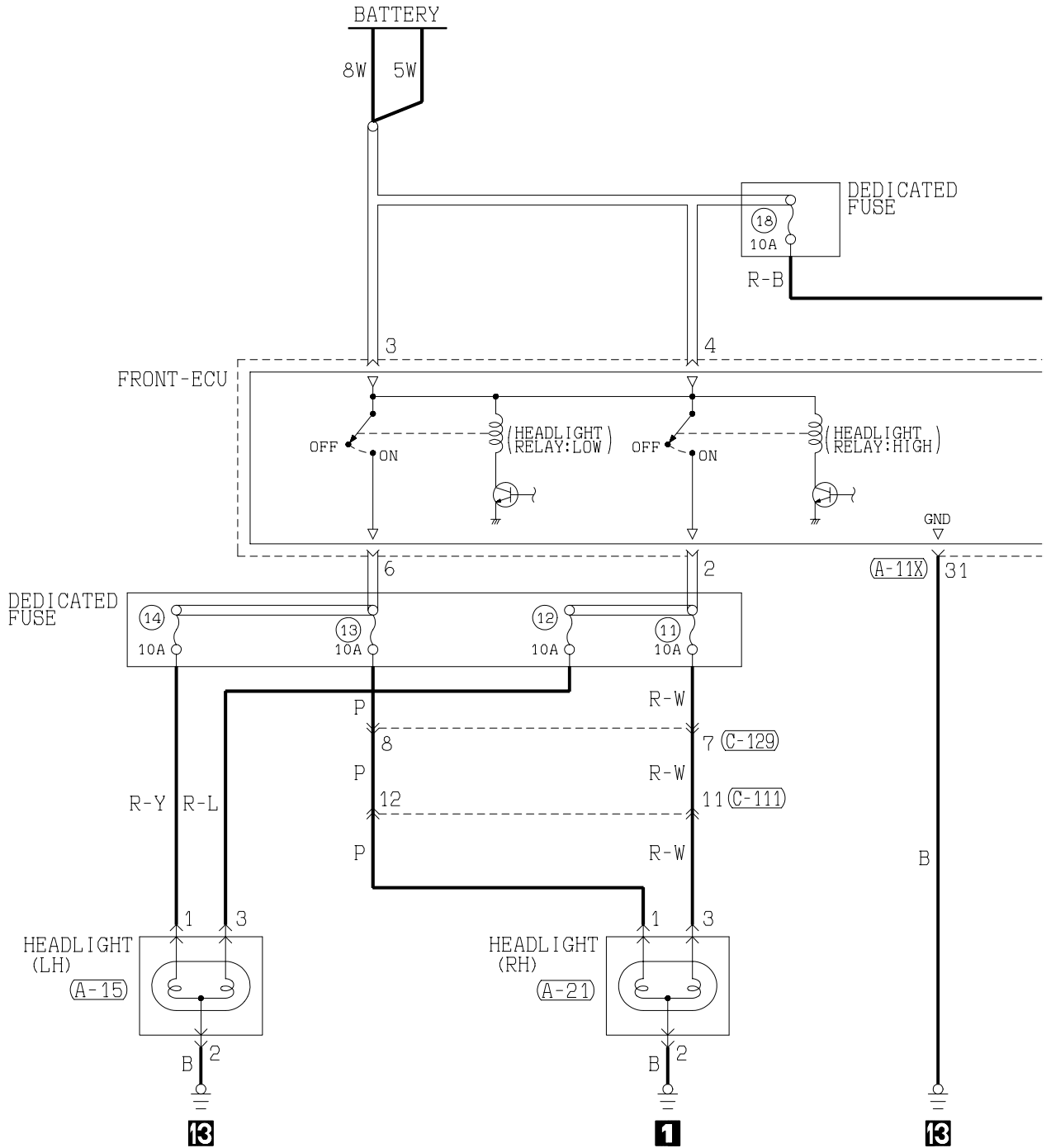

(A-10X)

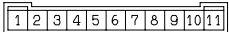

(A-11X)

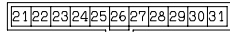

(A-15) (A-21)



(C-05)

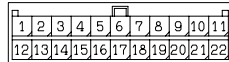

(C-06)

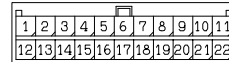

(C-129)

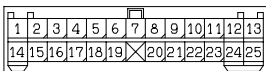

(C-206)

(MU801514)

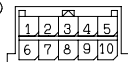

(C-210) MU801857

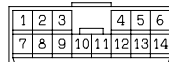

(C-211)

(MU801331)



H2J08M00AA

2

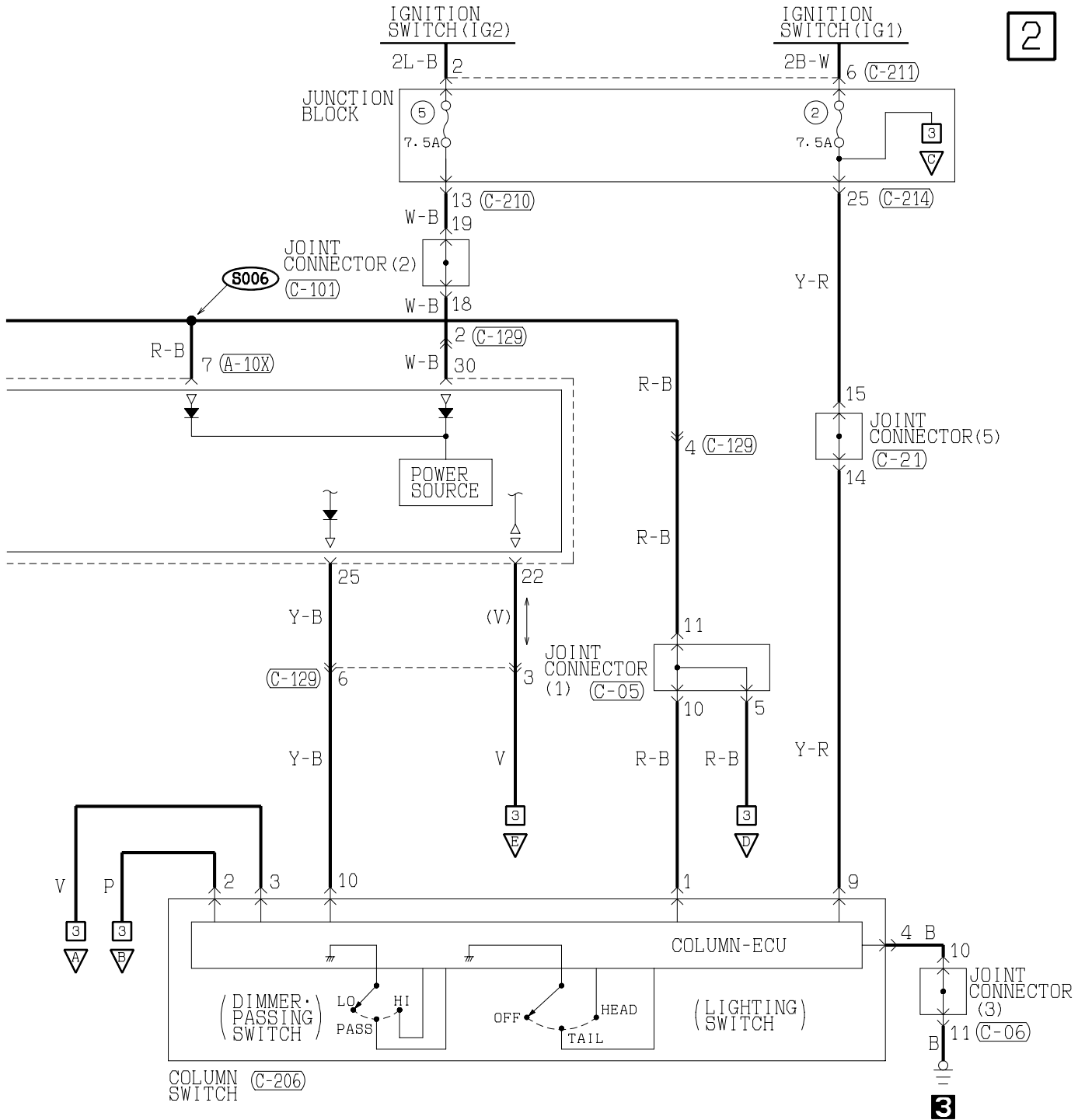

(C-21)

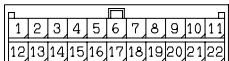

(C-214)

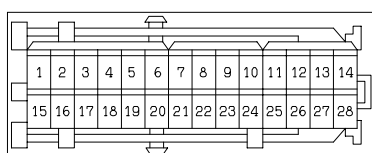

(C-101)

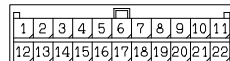

WIRE COLOR CODE
 B : BLACK LG : LIGHT GREEN
 BR : BROWN O : ORANGE
 W : WHITE SB : SKY BLUE
 V : VIOLET

(C-111)

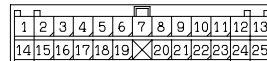

G : GREEN
 GR : GRAY
 P : PINK

L : BLUE
 R : RED
 Y : YELLOW

H2J08M00AB

HEADLIGHT (CONTINUED)

3

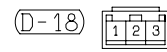
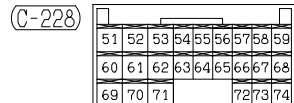
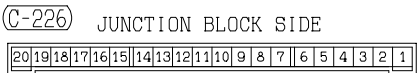
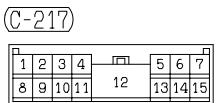
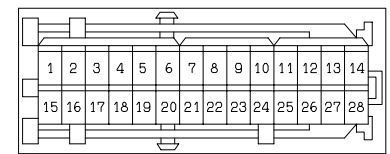
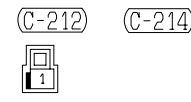
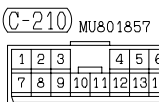
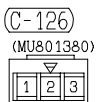
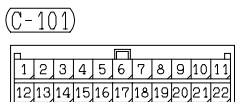
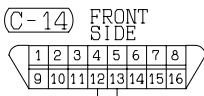
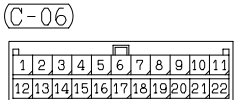
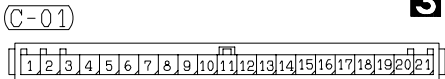
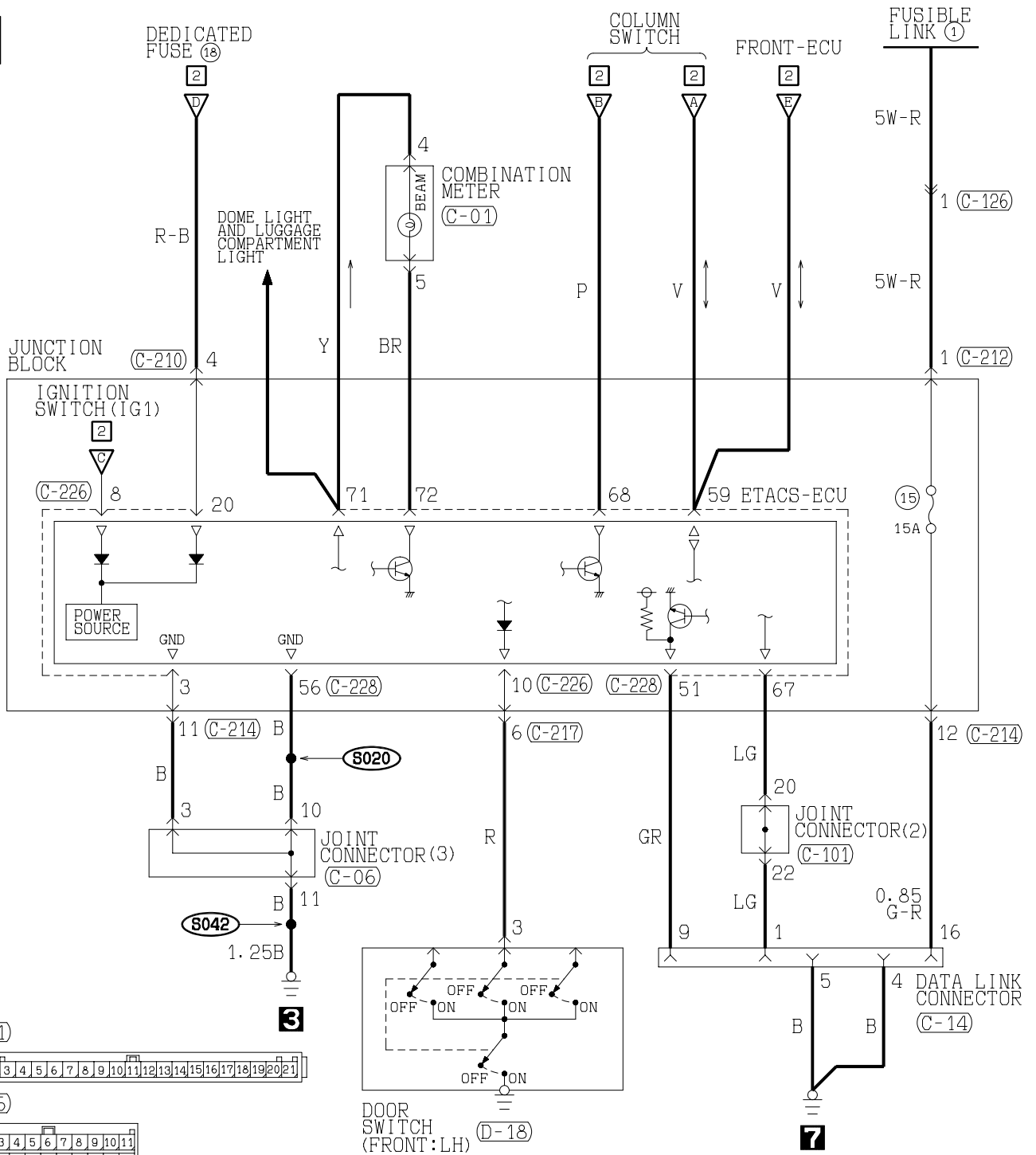

H2J08M00BA

NOTES

TAILLIGHT, POSITION LIGHT AND LICENSE PLATE LIGHT

M3030012600011

1

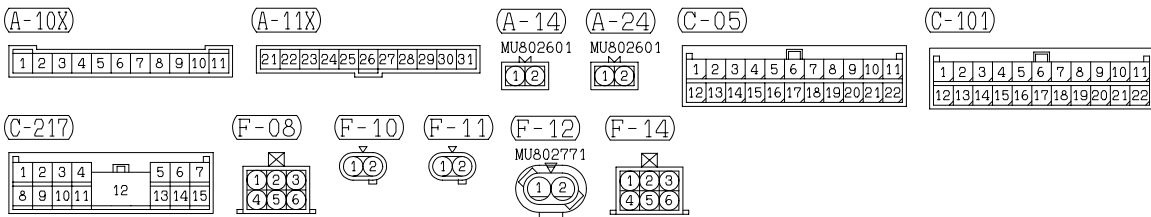
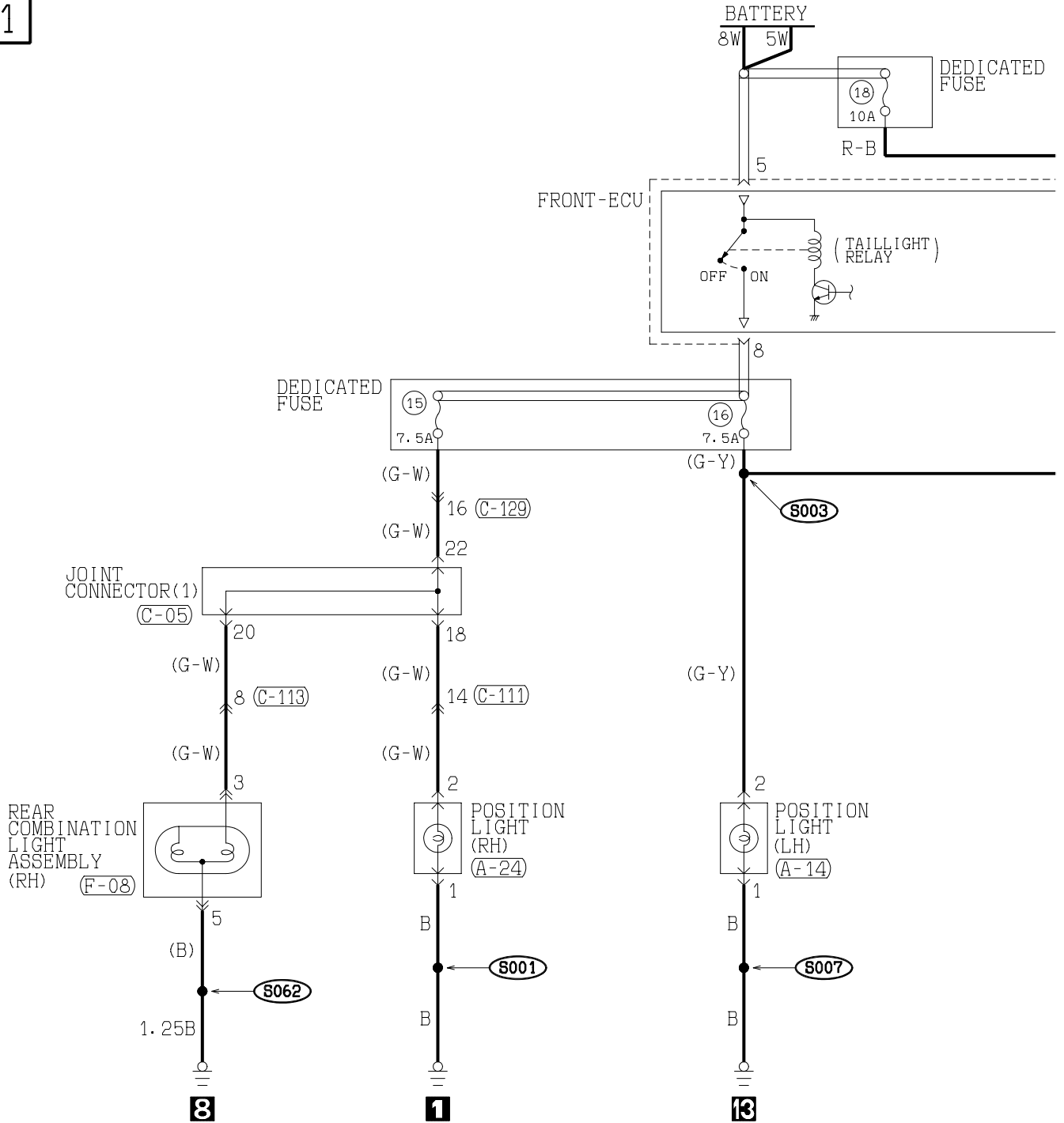

H2J08M01AA

TSB Revision

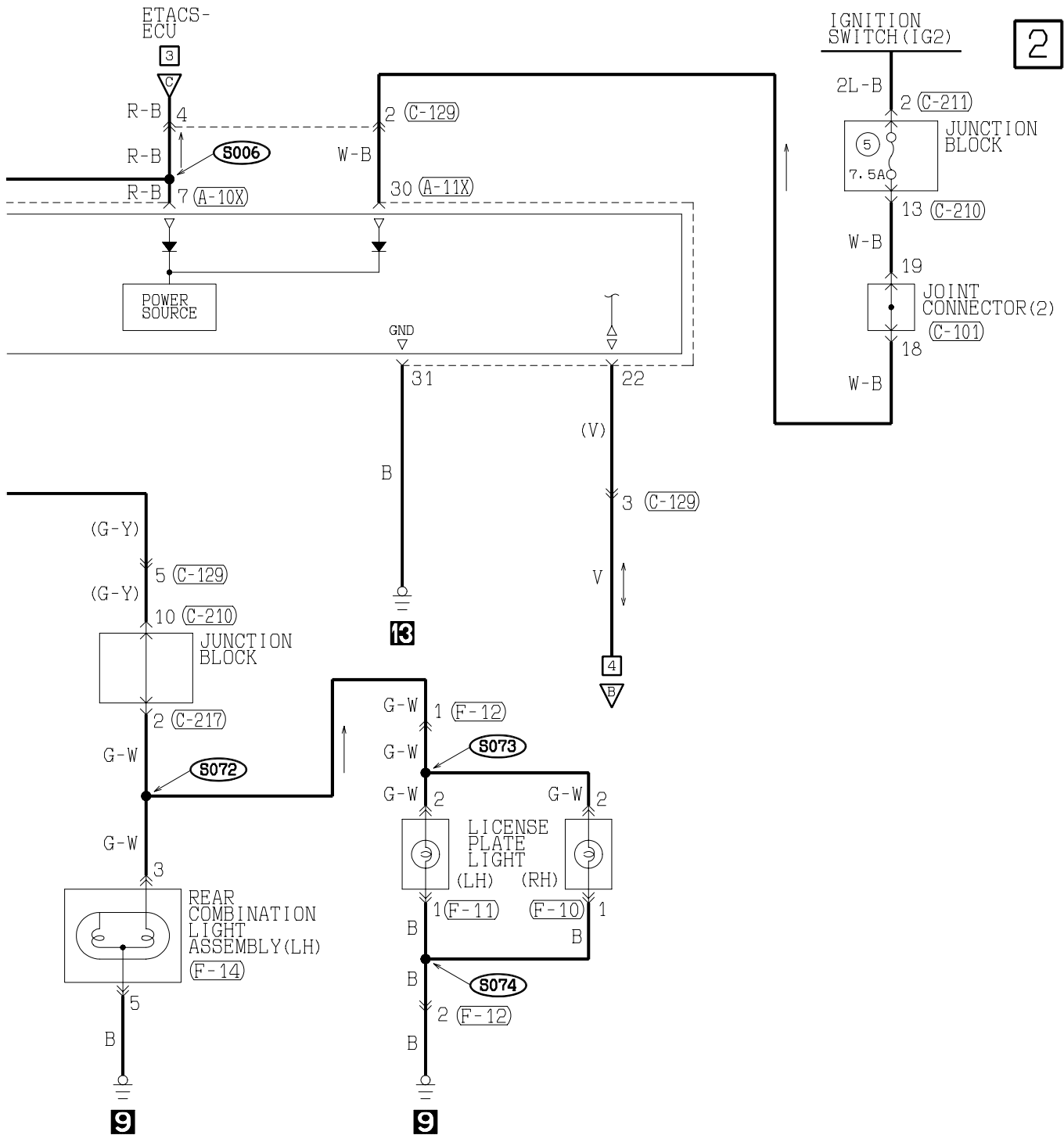

(C-111)

1	2	3	4	5	6	7	8	9	10	11	12	13
14	15	16	17	18	19	X	20	21	22	23	24	25

(C-113) MU801855

1	2	3	4	5
6	7	8	9	10
11	12	13		

(C-129)

1	2	3	4	5	6	7	8	9	10	11	12	13
14	15	16	17	18	19	X	20	21	22	23	24	25

(C-210) MU801857

1	2	3	4	5	6
7	8	9	10	11	12
13	14				

(C-211) MU801331

1	2
3	4
5	6

WIRE COLOR CODE
 B : BLACK LG : LIGHT GREEN G : GREEN L : BLUE W : WHITE Y : YELLOW SB : SKY BLUE
 BR : BROWN O : ORANGE GR : GRAY R : RED P : PINK V : VIOLET

H2J08M01AB

TAILLIGHT, POSITION LIGHT AND LICENSE PLATE LIGHT (CONTINUED)

3

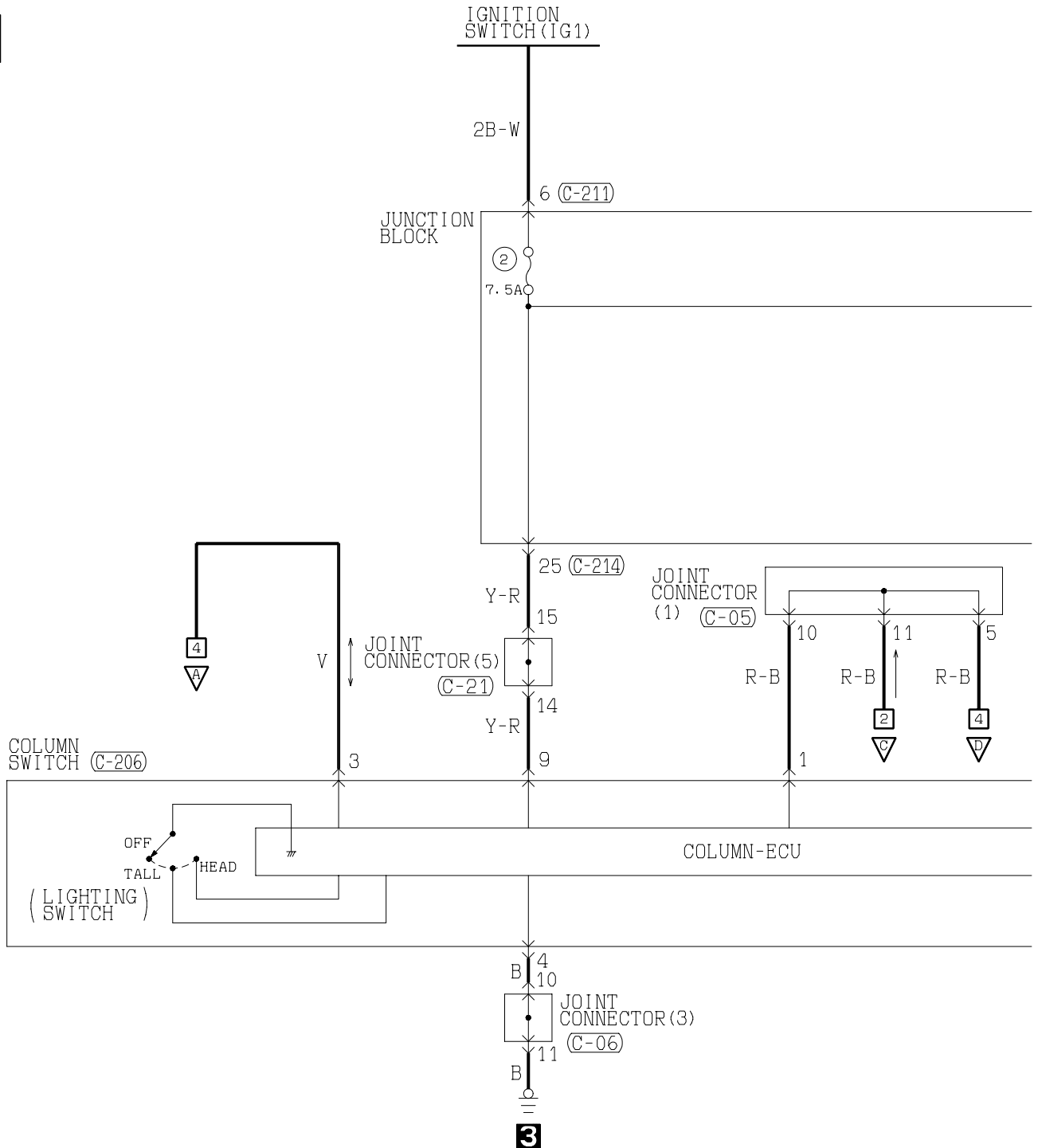

3

(C-05)

1	2	3	4	5	6	7	8	9	10	11
12	13	14	15	16	17	18	19	20	21	22

(C-06)

1	2	3	4	5	6	7	8	9	10	11
12	13	14	15	16	17	18	19	20	21	22

(C-14) FRONT SIDE

1	2	3	4	5	6	7	8
9	10	11	12	13	14	15	16

(C-21)

1	2	3	4	5	6	7	8	9	10	11
12	13	14	15	16	17	18	19	20	21	22

(C-101)

1	2	3	4	5	6	7	8	9	10	11
12	13	14	15	16	17	18	19	20	21	22

(C-226)

JUNCTION BLOCK SIDE

20	19	18	17	16	15	14	13	12	11	10	9	8	7	6	5	4	3	2	1
----	----	----	----	----	----	----	----	----	----	----	---	---	---	---	---	---	---	---	---

(C-228)

51	52	53	54	55	56	57	58	59
60	61	62	63	64	65	66	67	68
69	70	71	72	73	74			

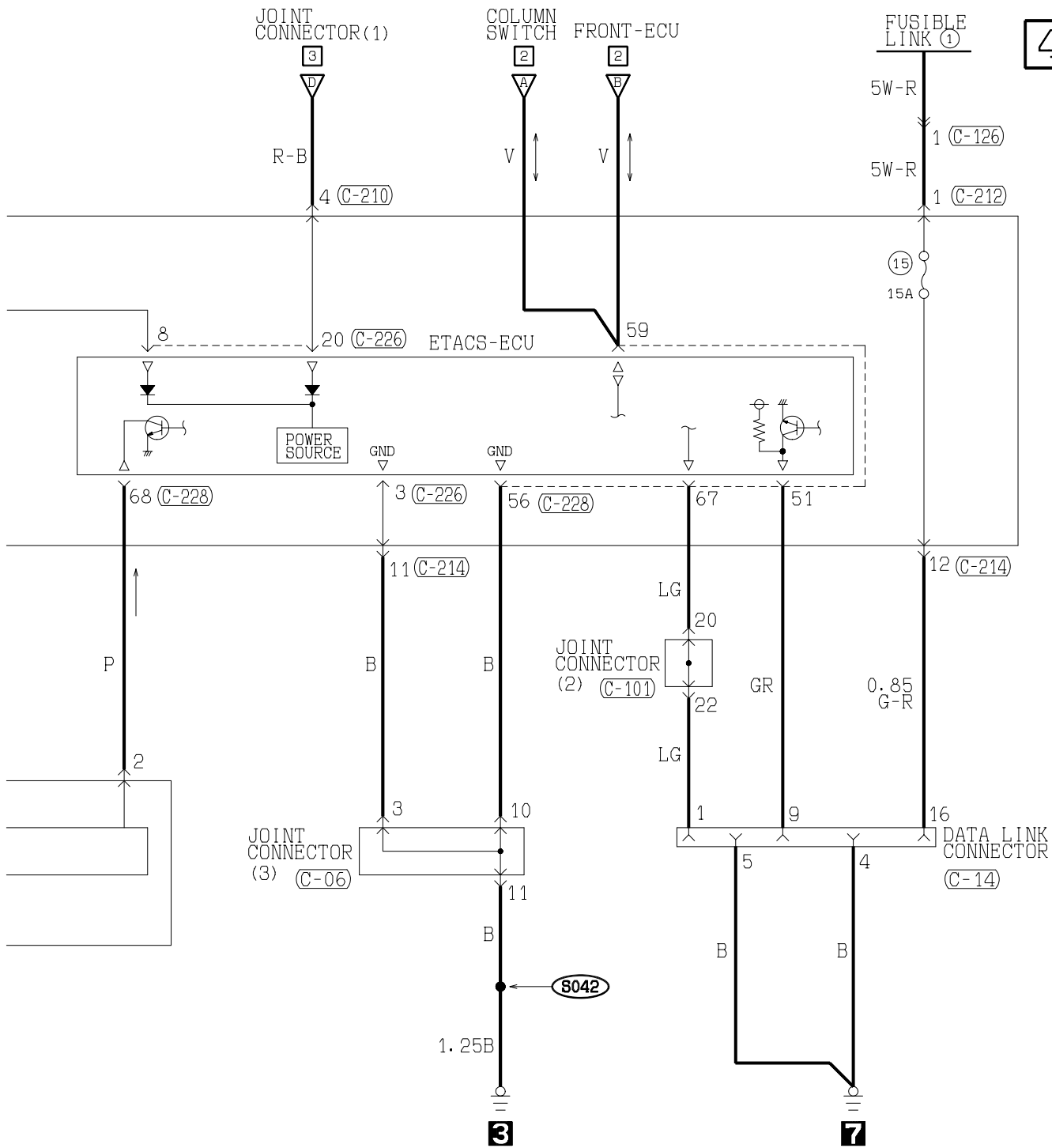

4

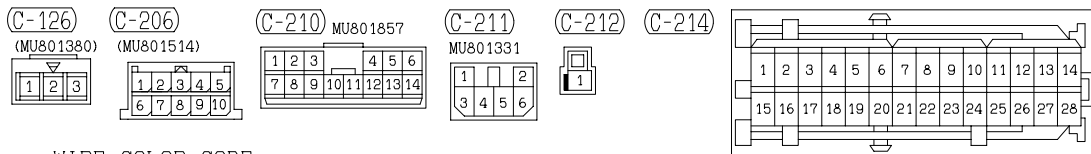

WIRE COLOR CODE
 B :BLACK LG:LIGHT GREEN G :GREEN L :BLUE W :WHITE Y :YELLOW SB:SKY BLUE
 BR:BROWN O :ORANGE GR:GRAY R :RED P :PINK V :VIOLET

H2J08M01BB

DOME LIGHT AND LUGGAGE COMPARTMENT LIGHT

M3030013200027

1

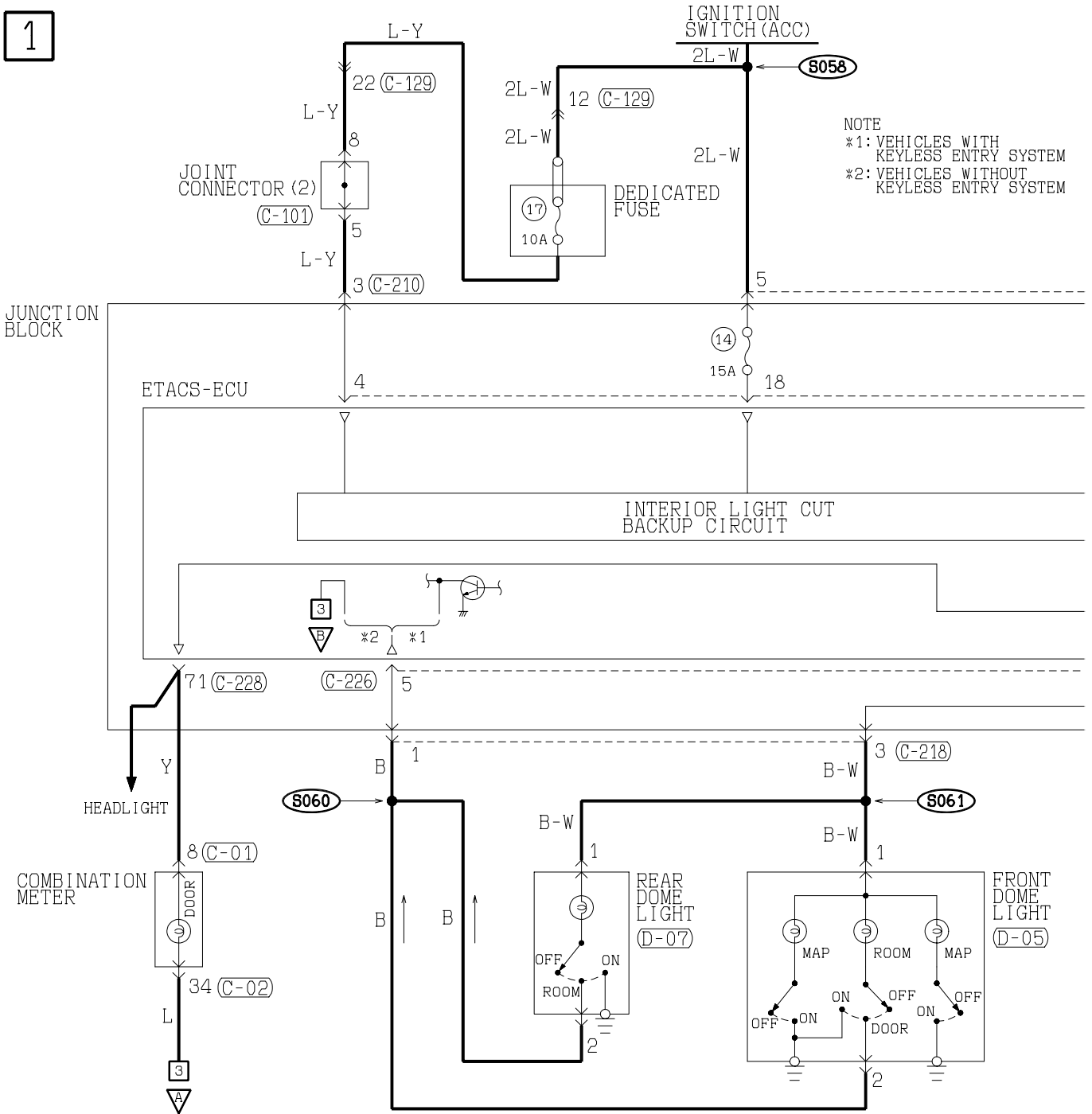

NOTE
*1: VEHICLES WITH KEYLESS ENTRY SYSTEM
*2: VEHICLES WITHOUT KEYLESS ENTRY SYSTEM

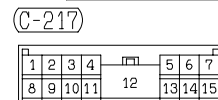
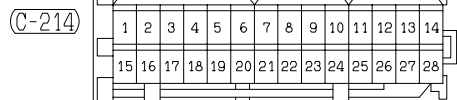
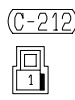
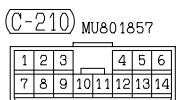
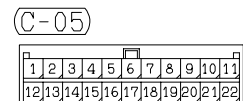
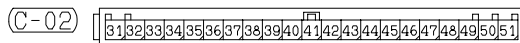

H2J08M02AA

TSB Revision

CIRCUIT DIAGRAMS DOME LIGHT AND LUGGAGE COMPARTMENT LIGHT

90-67

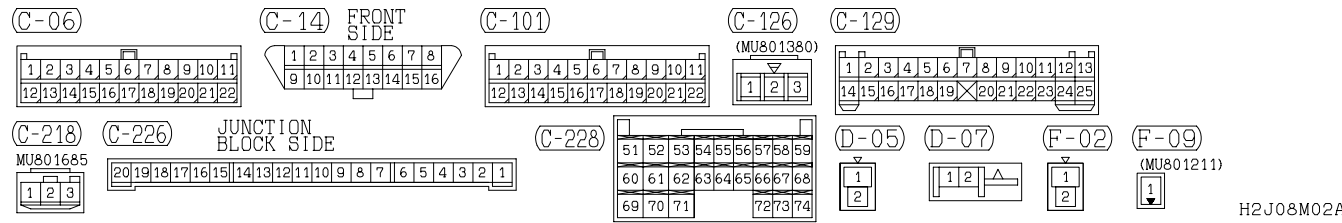
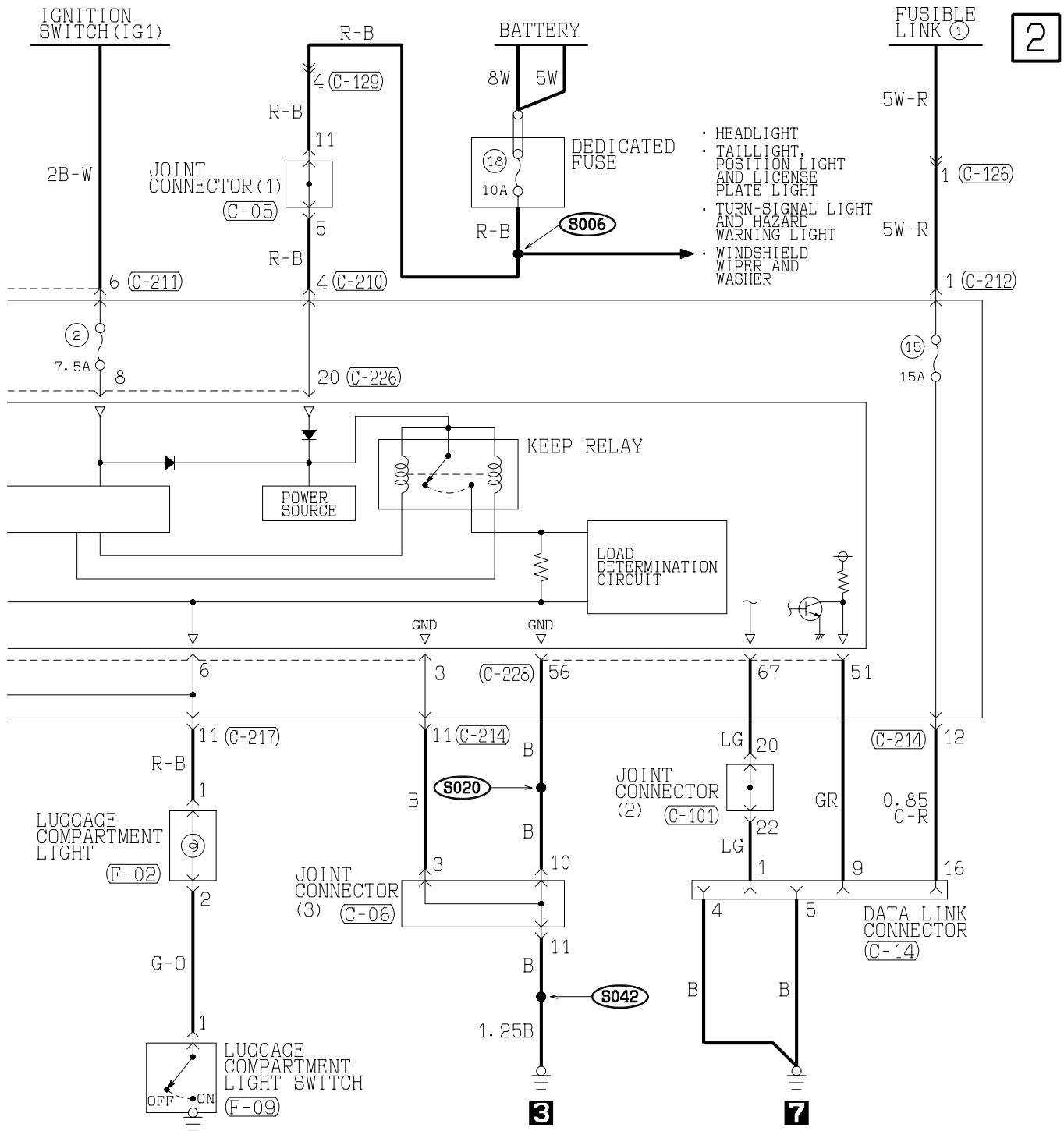

H2J08M02AB

TSB Revision

DOME LIGHT AND LUGGAGE COMPARTMENT LIGHT (CONTINUED)

3

NOTE
*1: VEHICLES WITH
KEYLESS ENTRY SYSTEM
*2: VEHICLES WITHOUT
KEYLESS ENTRY SYSTEM

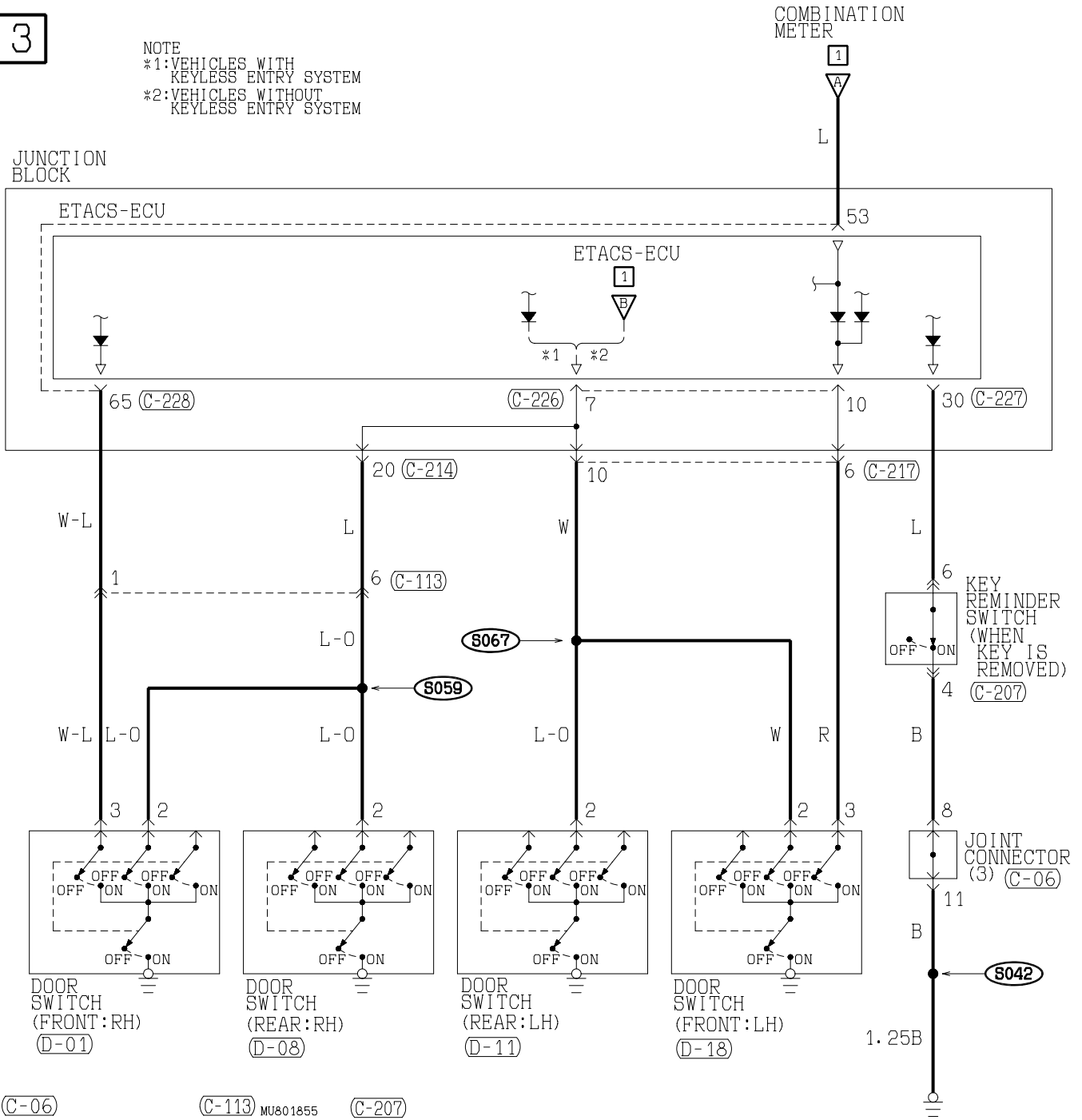

C-06

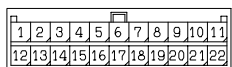

C-113 MU801855

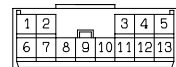

C-207 MU801547

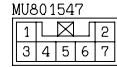

C-214

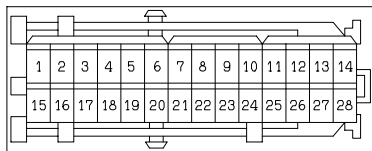

C-217

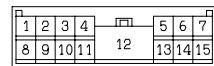

C-226 JUNCTION BLOCK SIDE

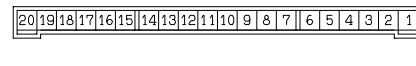

C-227

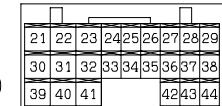

C-228

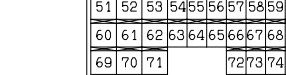

D-01



D-08



D-11



D-18



NOTES

TURN-SIGNAL LIGHT AND HAZARD WARNING LIGHT

M3030002900033

1

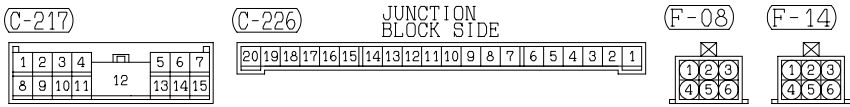
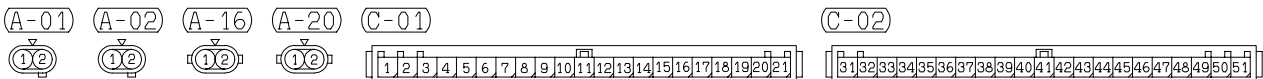
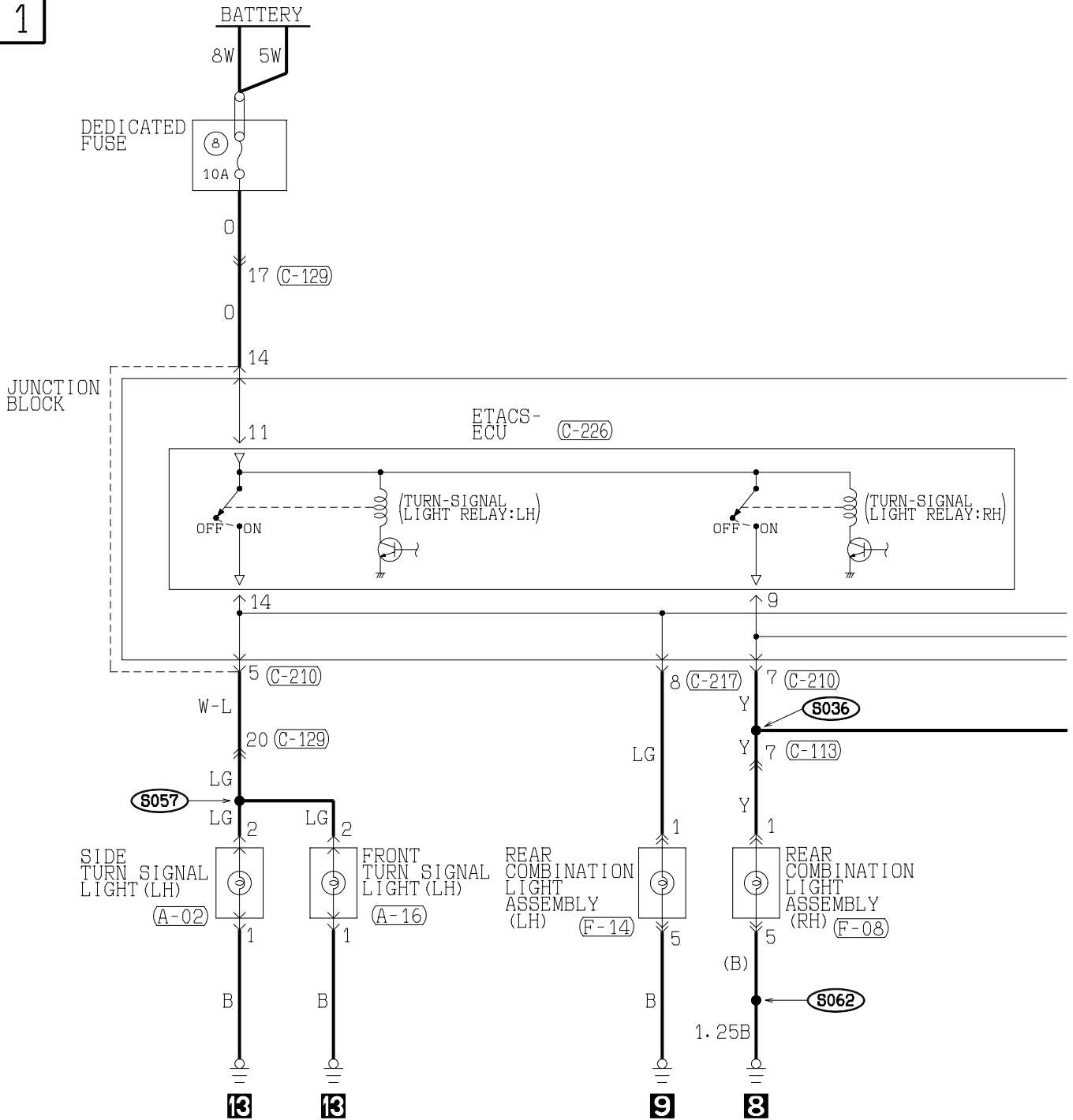

H2J09M00AA

TSB Revision

2

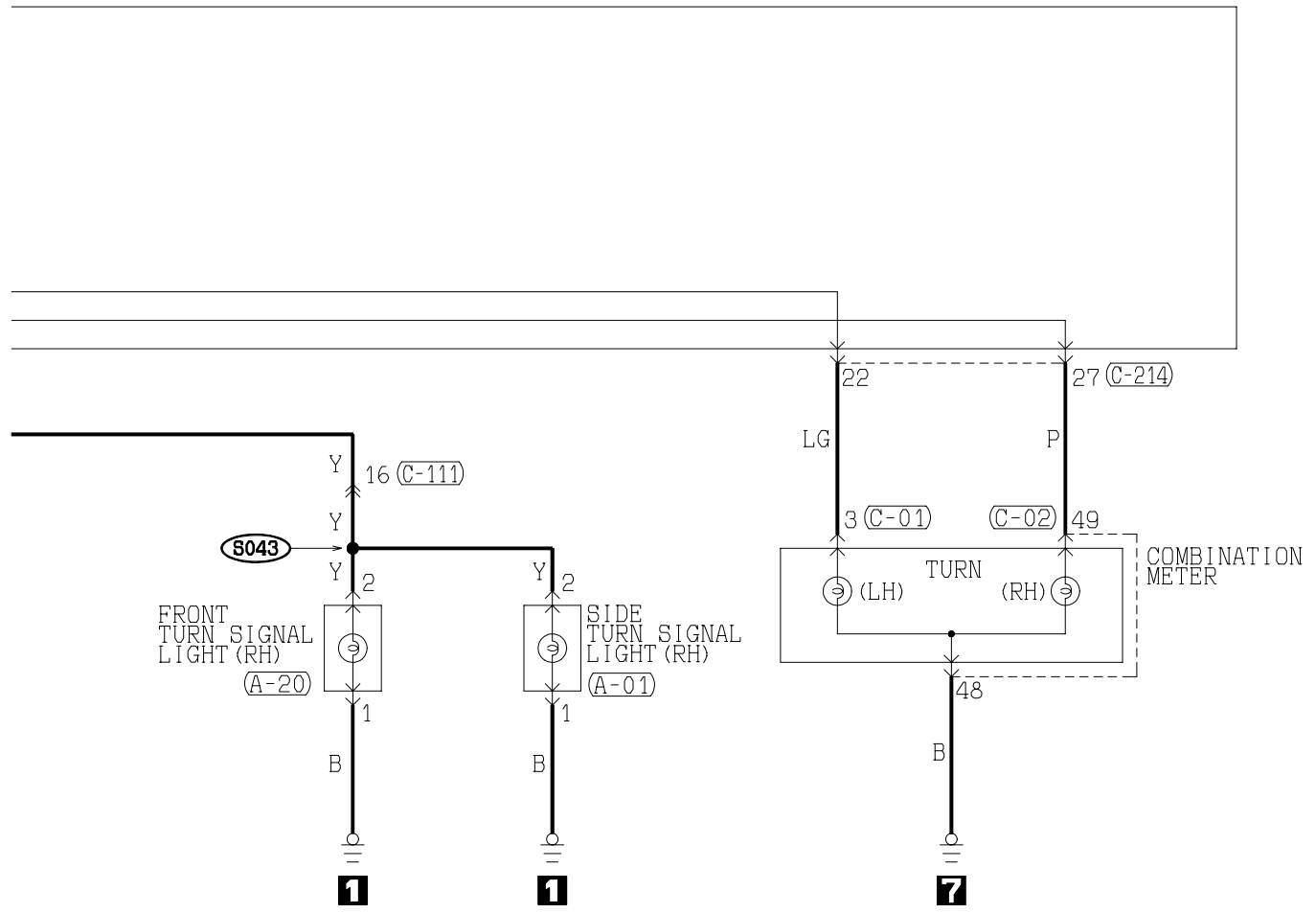

(C-111)

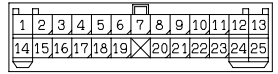

(C-113) MU801855

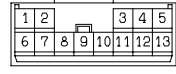

(C-129)

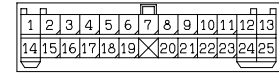

(C-210) MU801857

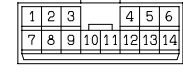

(C-214)

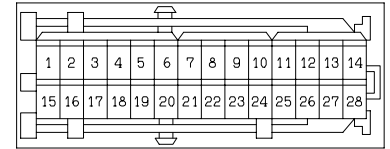

WIRE COLOR CODE
 B : BLACK LG : LIGHT GREEN G : GREEN L : BLUE
 BR : BROWN O : ORANGE GR : GRAY R : RED
 W : WHITE SB : SKY BLUE P : PINK Y : YELLOW
 V : VIOLET

H2J09M00AB

TURN-SIGNAL LIGHT AND HAZARD WARNING LIGHT (CONTINUED)

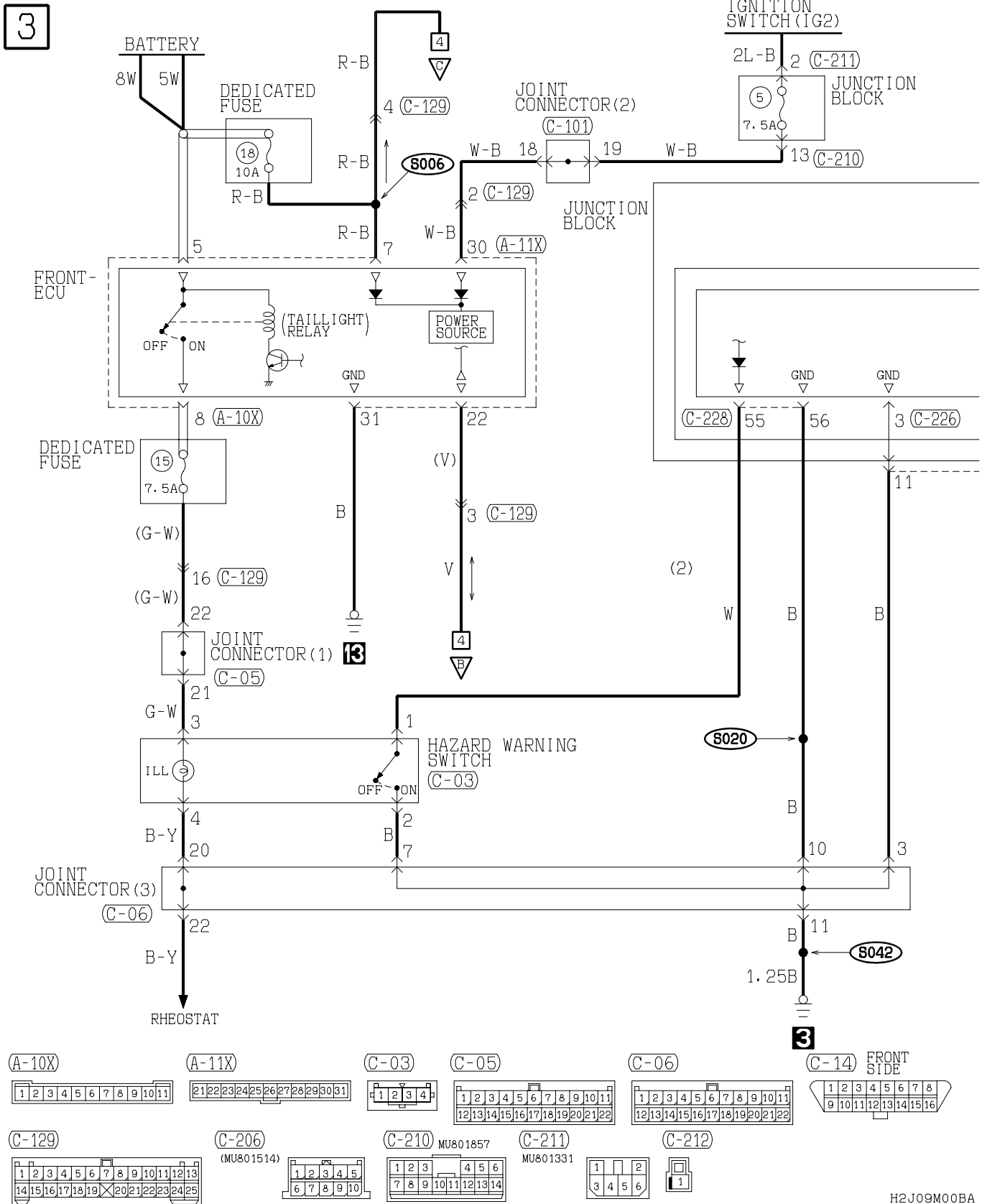

CIRCUIT DIAGRAMS TURN-SIGNAL LIGHT AND HAZARD WARNING LIGHT

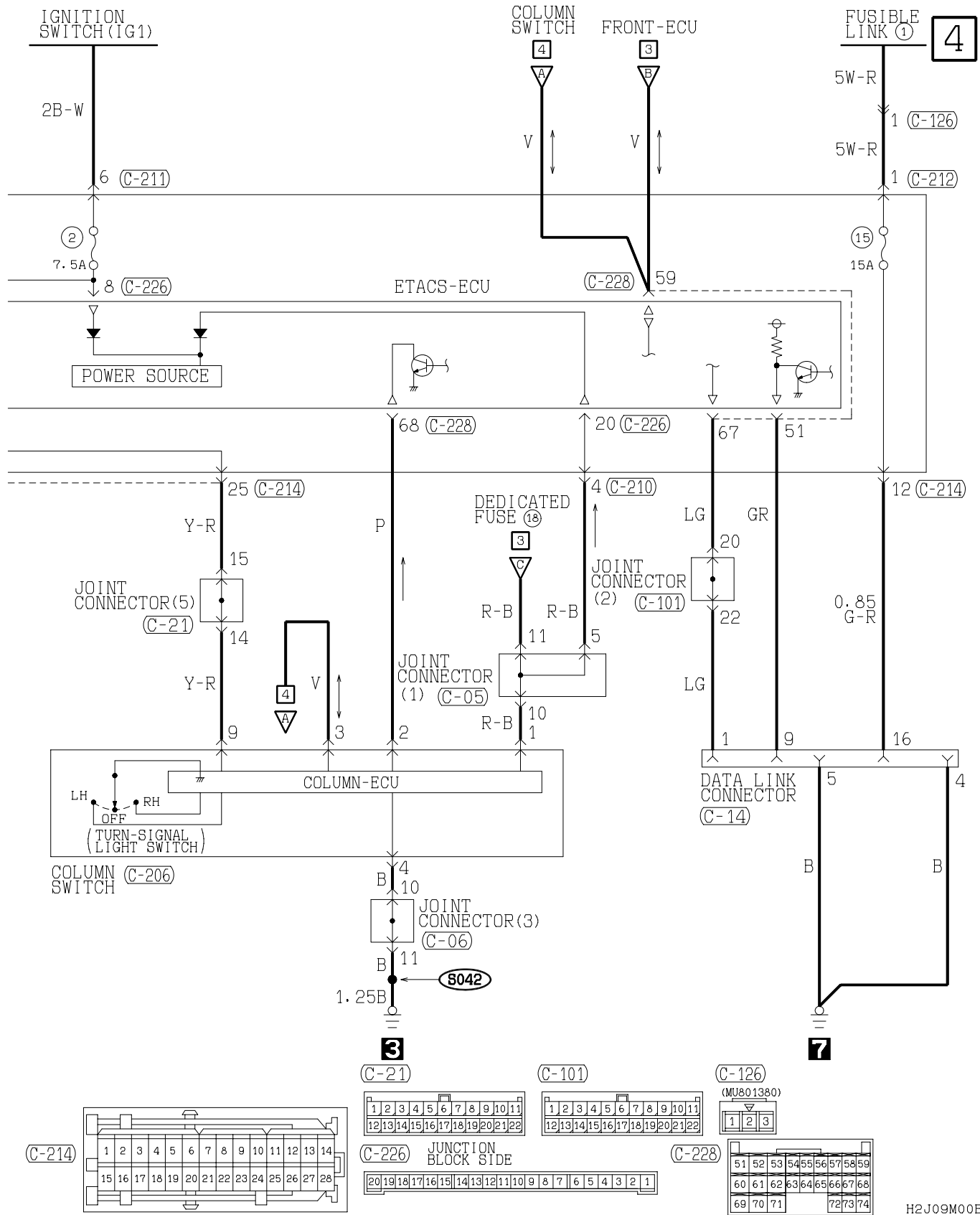

STOPLIGHT

M3030003000022

1

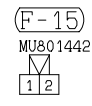
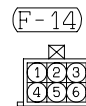
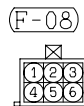
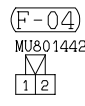
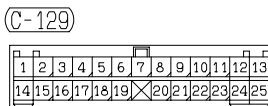
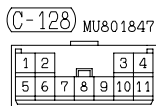
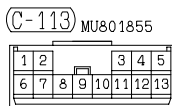
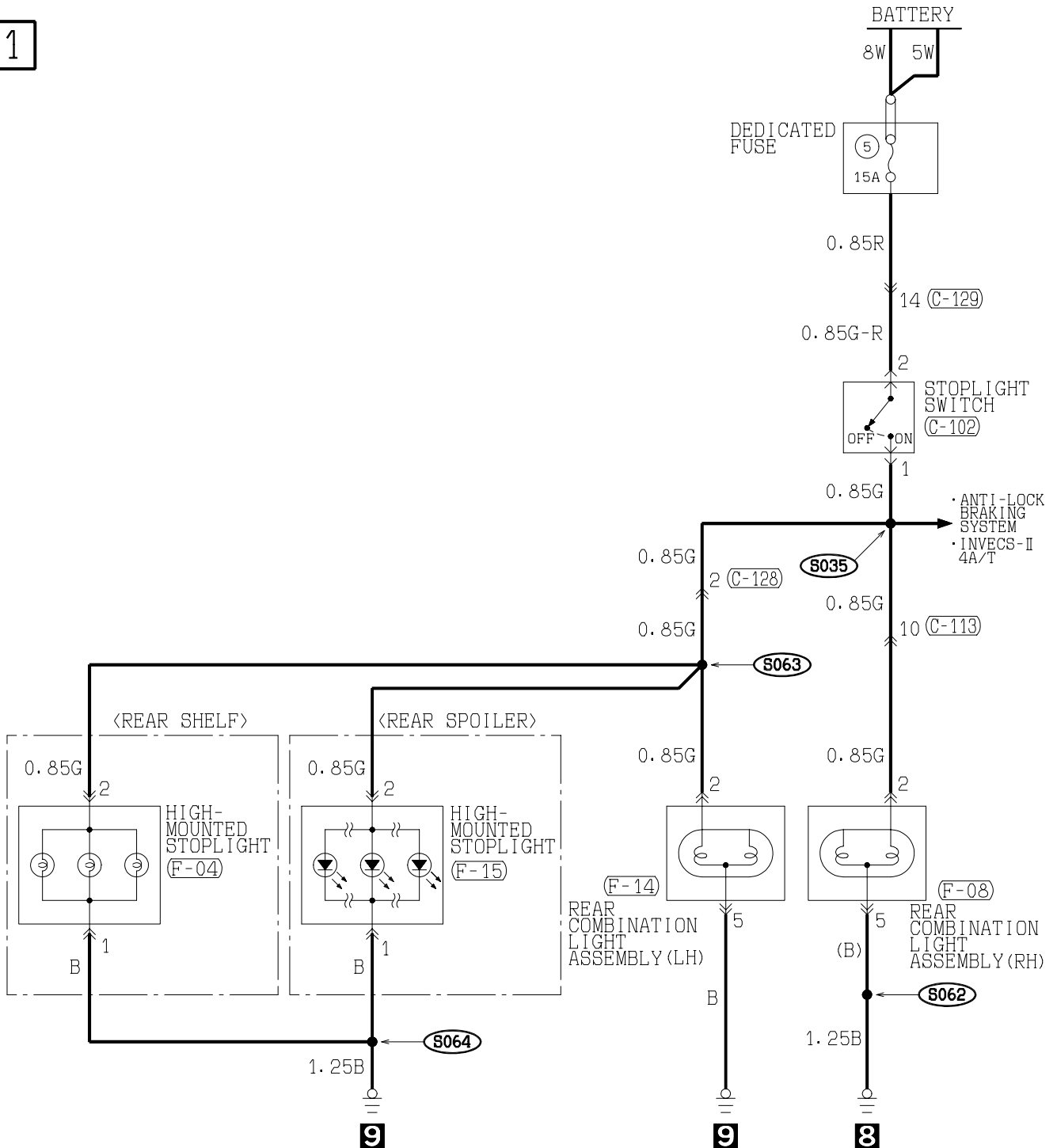

WIRE COLOR CODE
 B:BLACK LG:LIGHT GREEN G:GREEN L:BLUE W:WHITE Y:YELLOW SB:SKY BLUE
 BR:BROWN O:ORANGE GR:GRAY R:RED P:PINK V:VIOLET

H2J09M01AA

BACKUP LIGHT

1

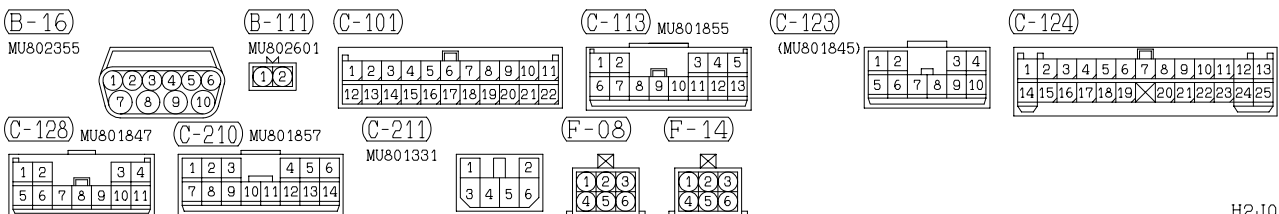
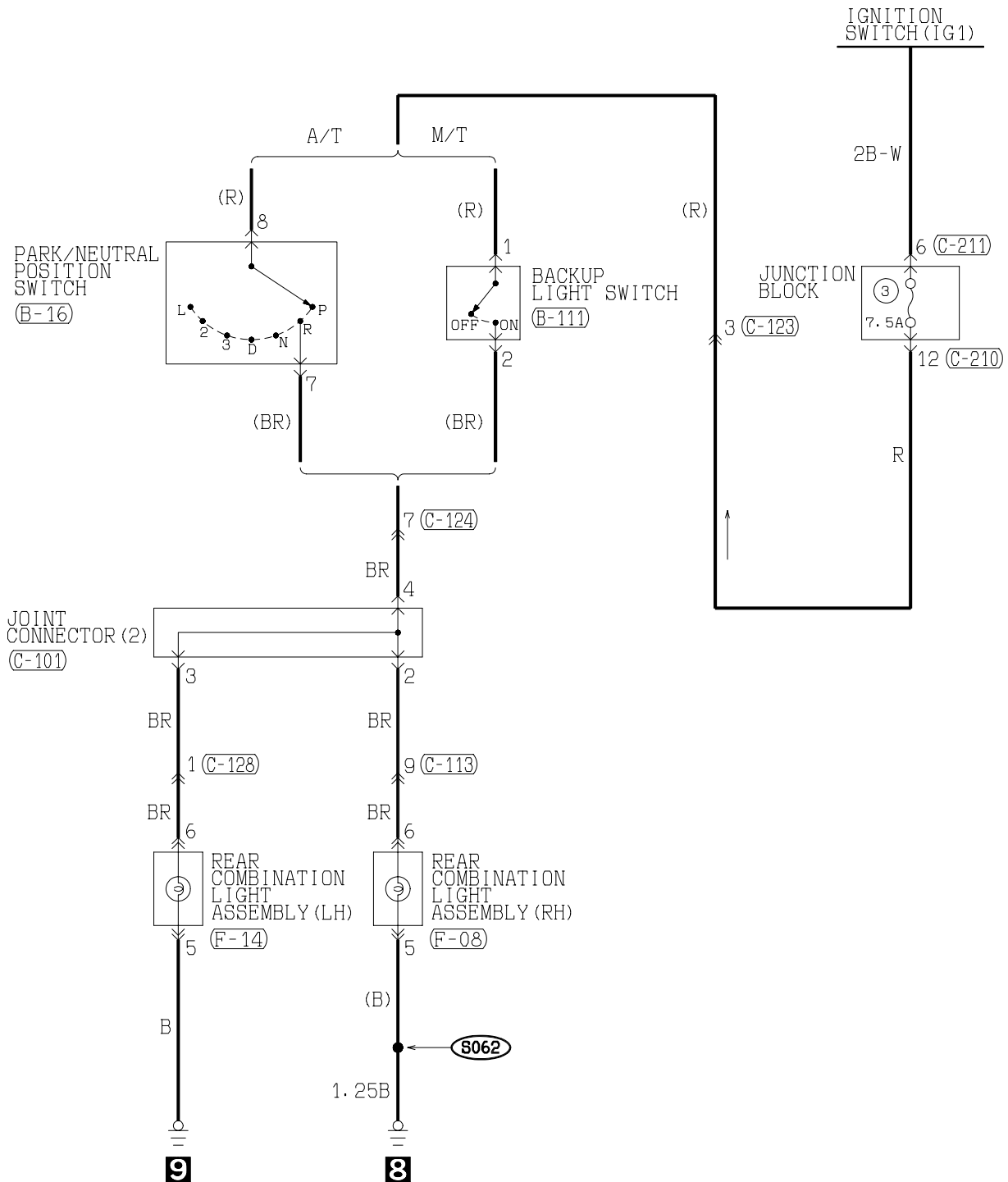

HORN

1

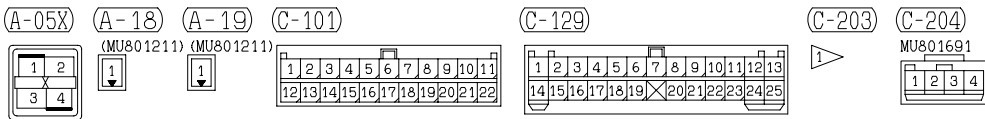
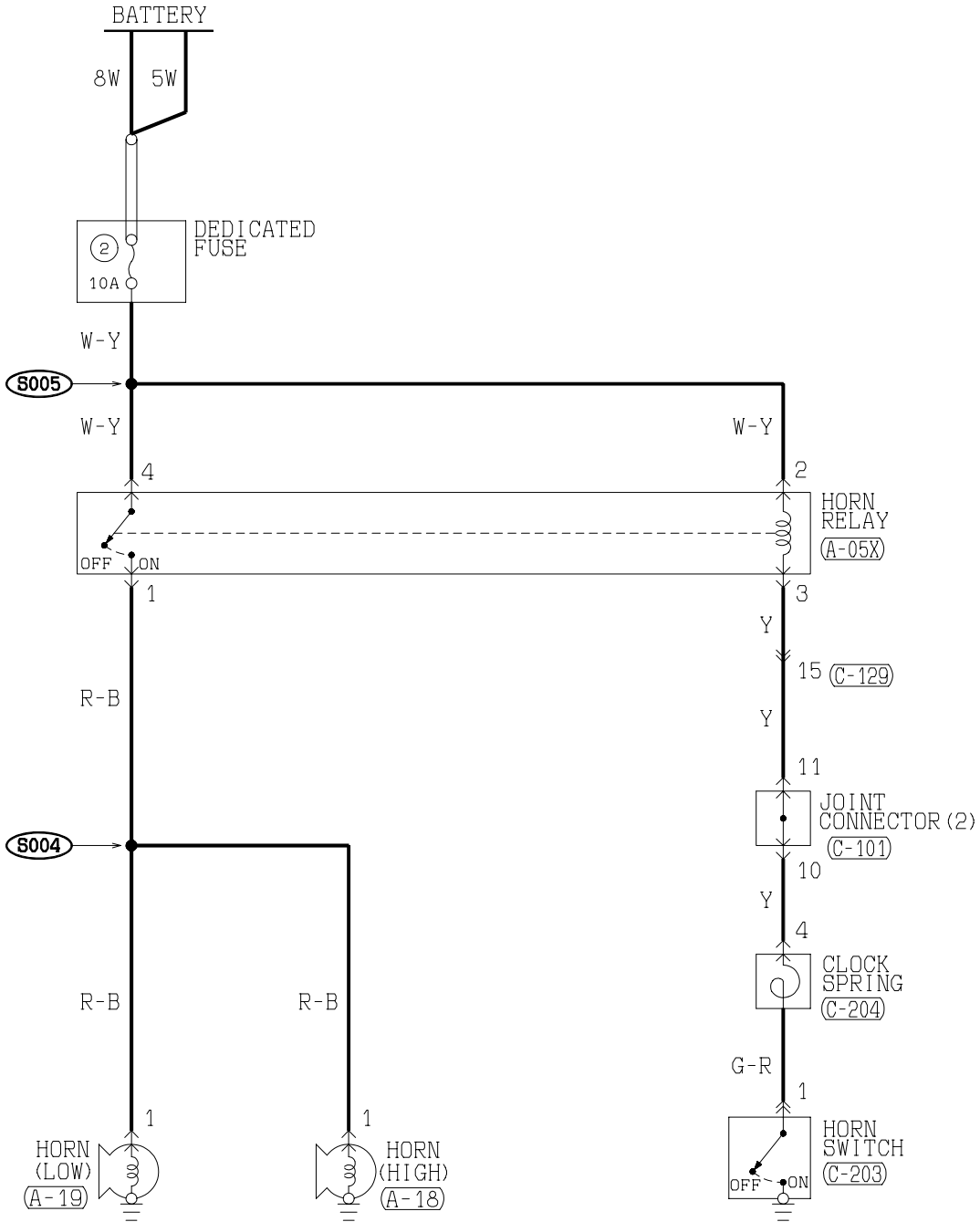

WIRE COLOR CODE
 B : BLACK LG : LIGHT GREEN G : GREEN L : BLUE W : WHITE Y : YELLOW SB : SKY BLUE
 BR : BROWN O : ORANGE GR : GRAY R : RED P : PINK V : VIOLET

NOTES

METER AND GAUGE

M3030003500038

1

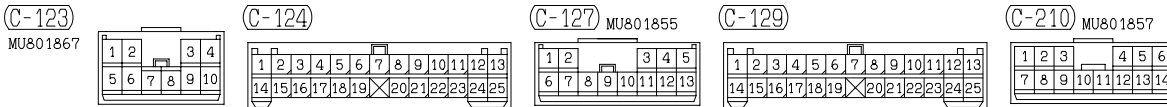
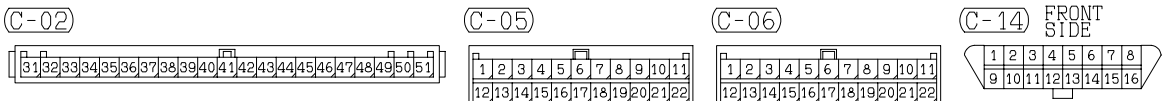
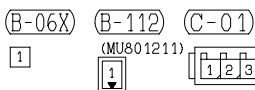
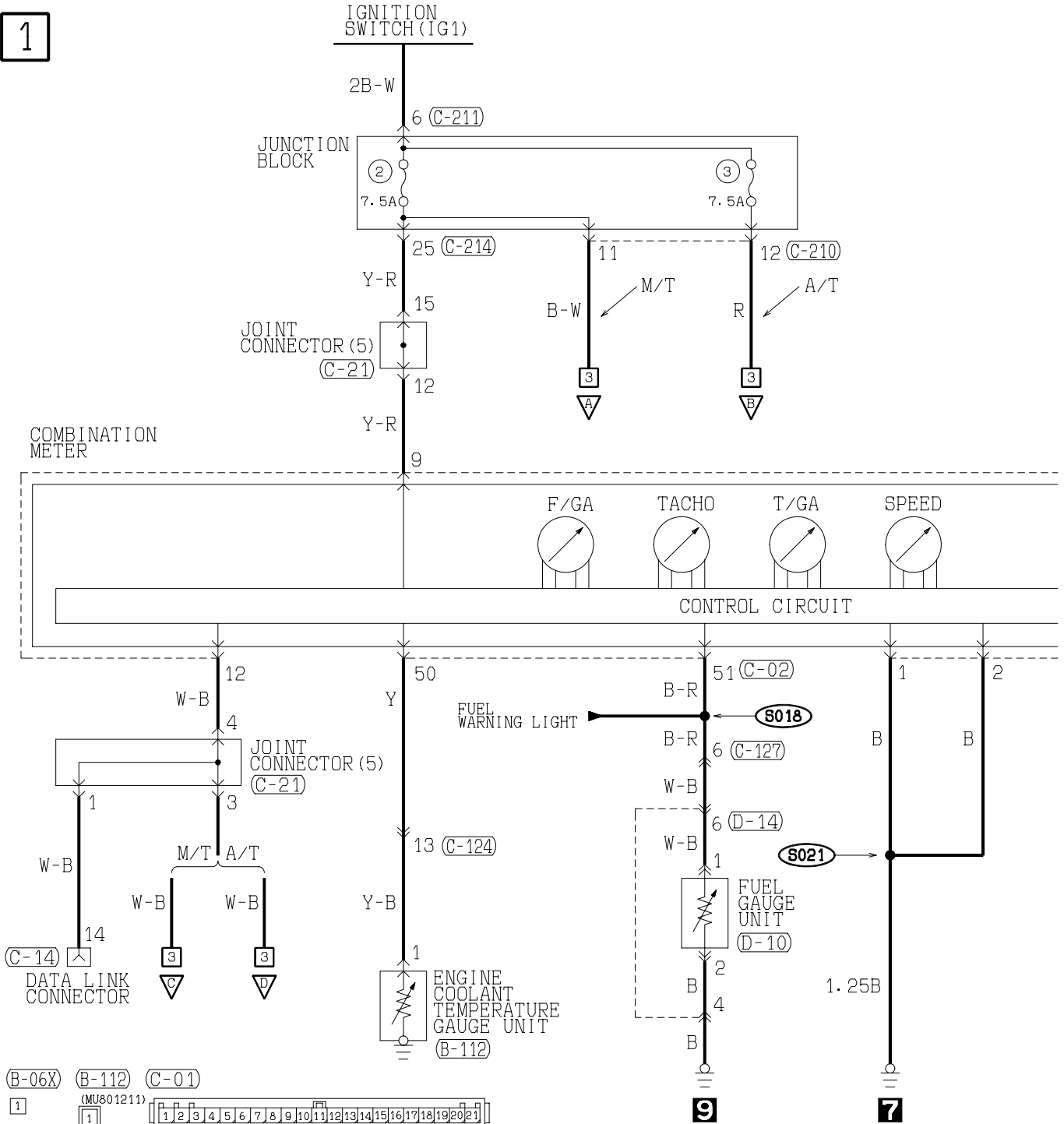

H2J10M00AA

TSB Revision

2

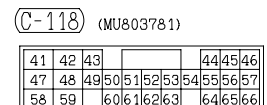
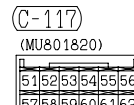
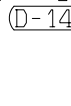
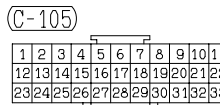
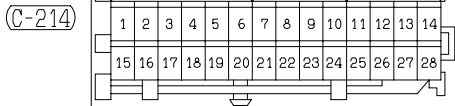
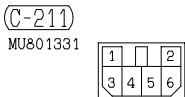
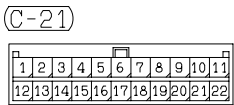
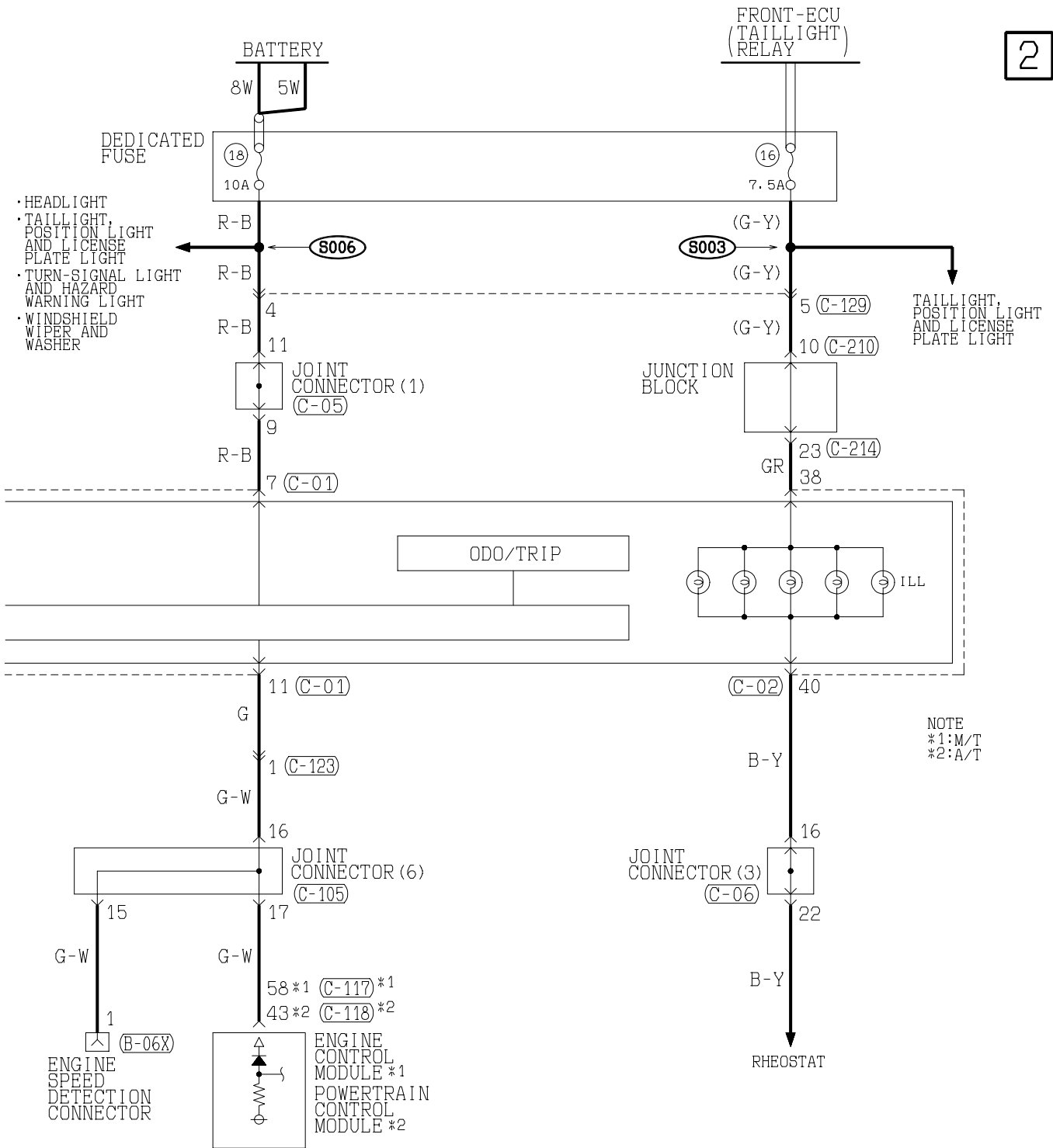

METER AND GAUGE (CONTINUED)

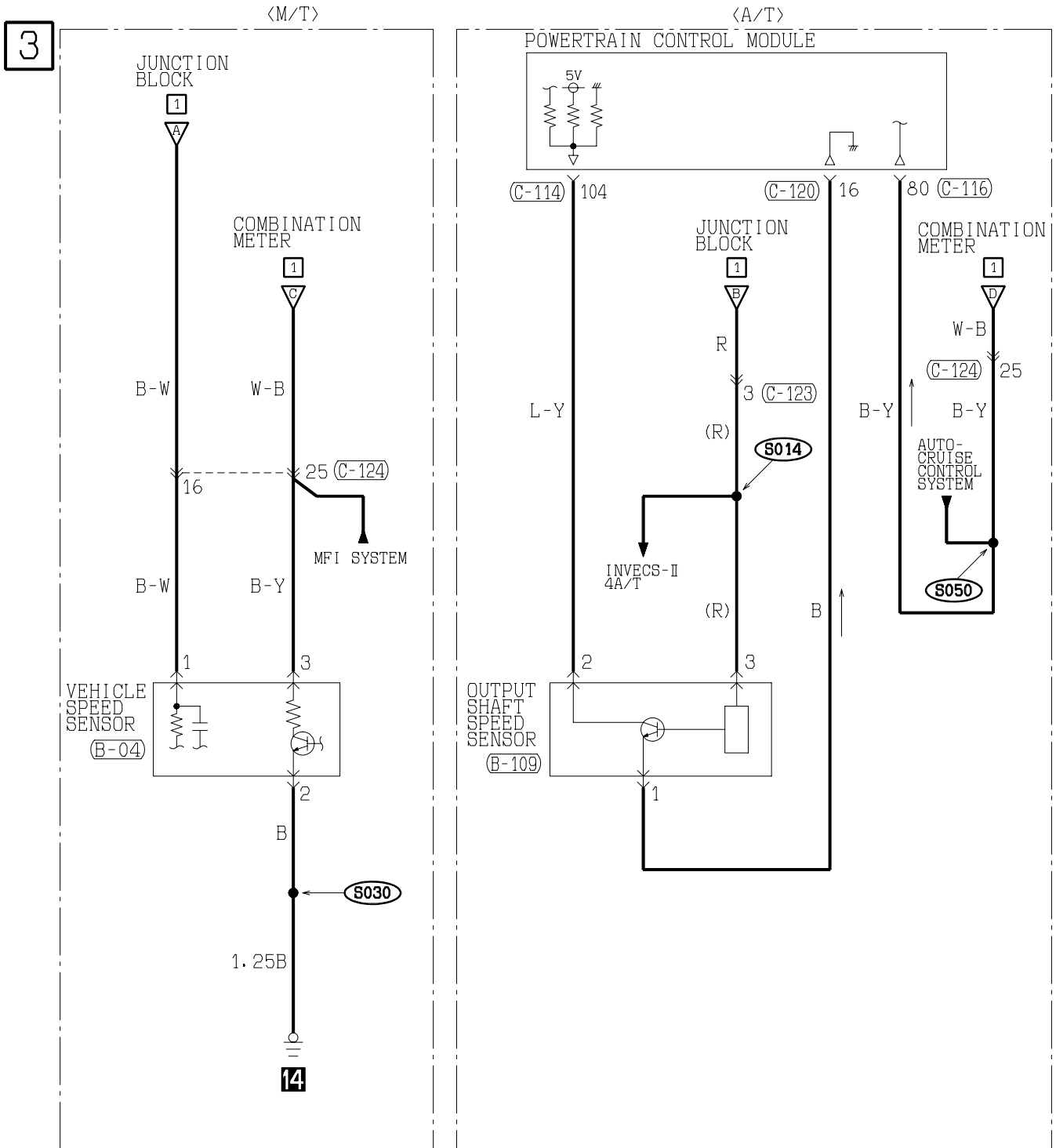

(B-04) (MU802723)

1	2	3
---	---	---

(B-109)

1	2	3
---	---	---

(C-114) (MU803783)

101	102	103	104	105	106	107						
108	109	110	111	112	113	114	115	116	117	118	119	120
121	122	123	124	125	126	127	128	129	130			

(C-116) (MU803782)

71	72	73	74	75	76	77					
78	79	80	81	82	83	84	85	86	87	88	89
90	91	92	93	94	95	96	97	98			

(C-120) (MU803784)

1	2	3	4	5	6	7	8							
9	10	11	12	13	14	15	16	17	18	19	20	21	22	23
24	25	26	27	28	29	30	31	32	33	34	35			

(C-123) MU801867

1	2	3	4		
5	6	7	8	9	10

(C-124)

1	2	3	4	5	6	7	8	9	10	11	12	13
14	15	16	17	18	19	20	21	22	23	24	25	

WIRE COLOR CODE

B : BLACK LG : LIGHT GREEN G : GREEN L : BLUE

BR : BROWN O : ORANGE GR : GRAY R : RED

W : WHITE SB : SKY BLUE P : PINK Y : YELLOW

V : VIOLET

H2J10M00BA

NOTES

BRAKE WARNING LIGHT, OIL PRESSURE WARNING LIGHT, FUEL WARNING LIGHT

M3030011800023

1

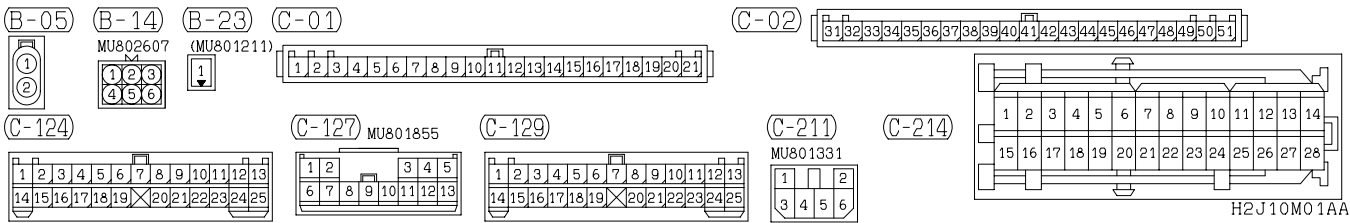
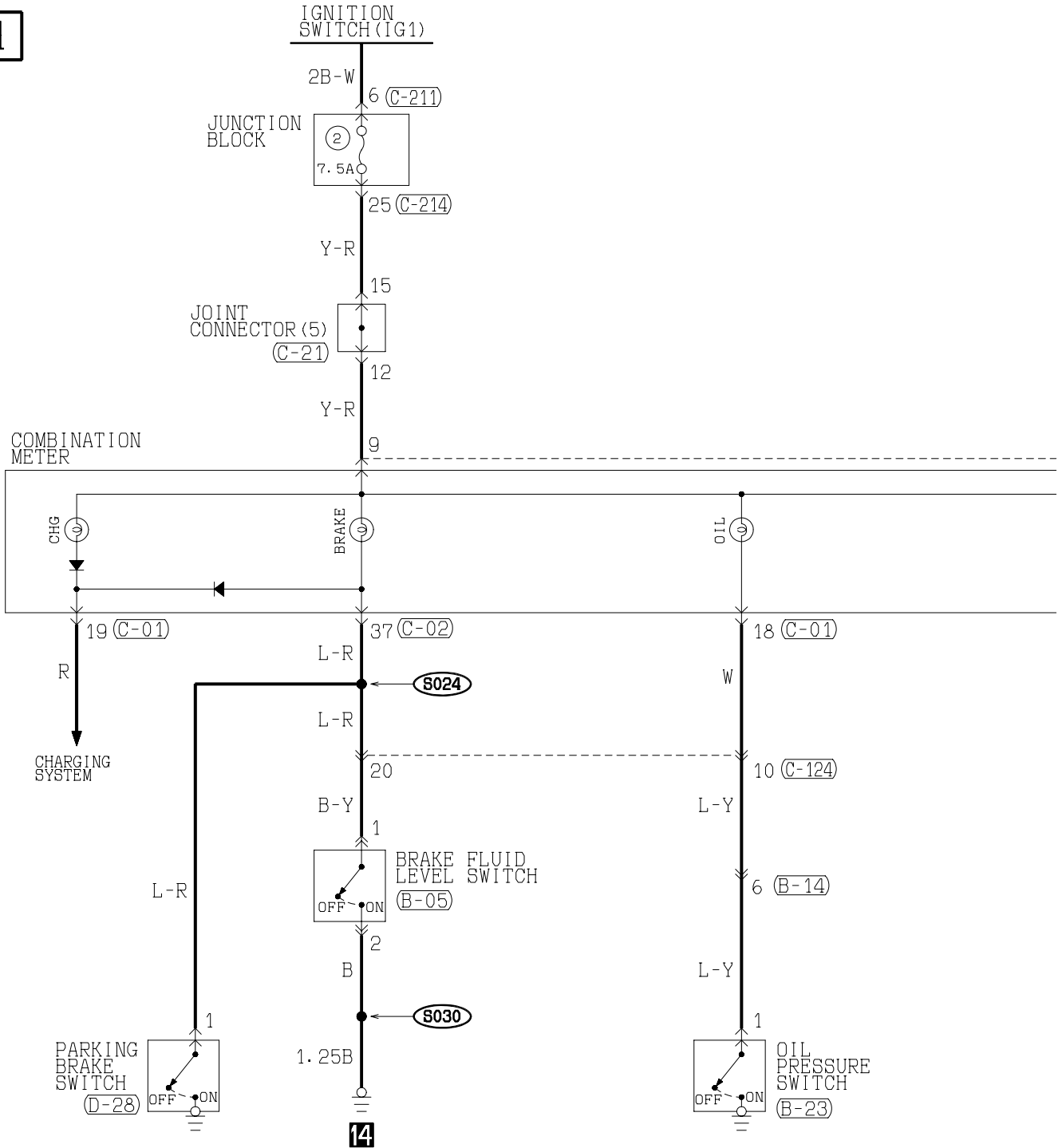

H2J10M01AA

TSB Revision

2

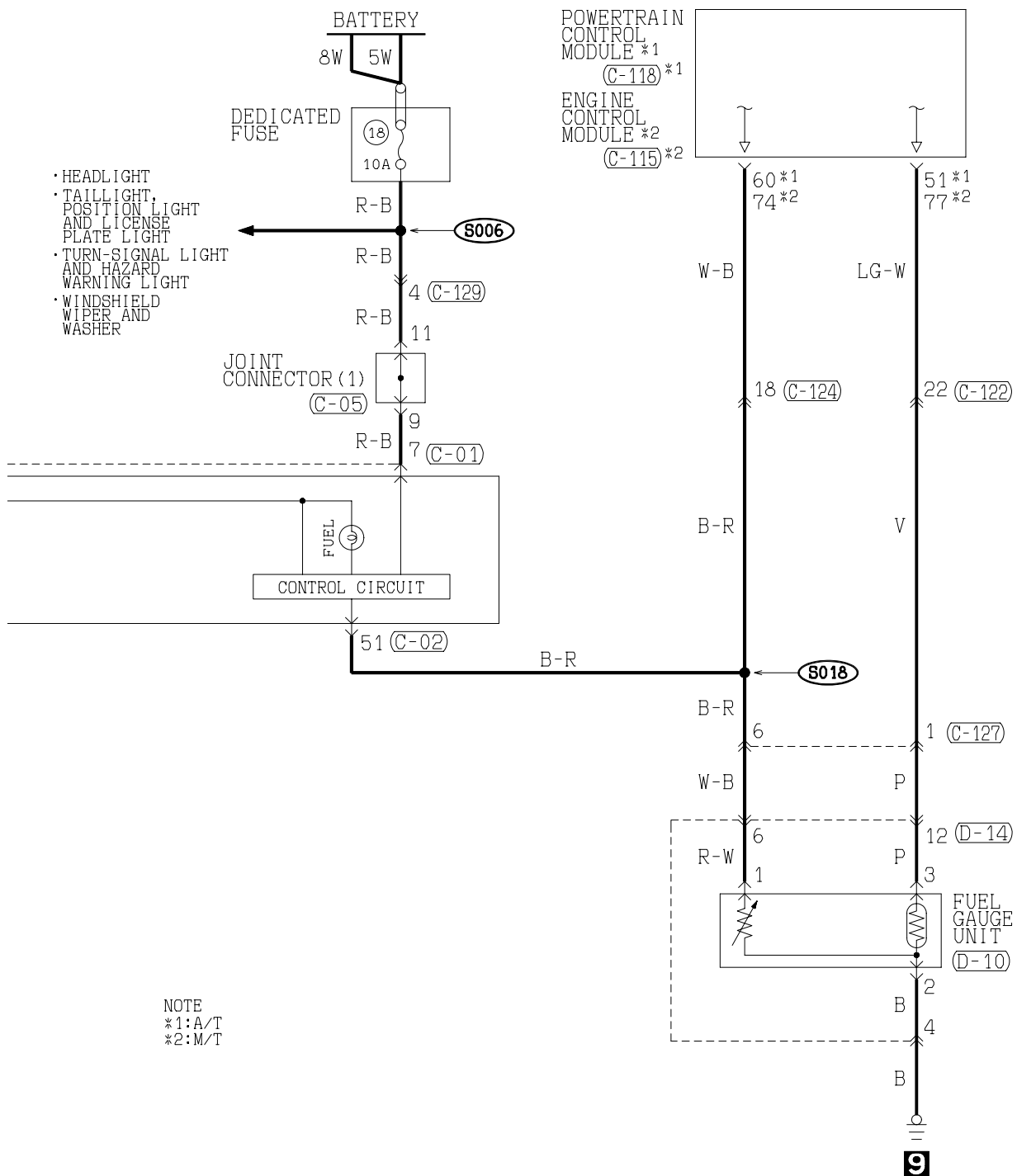

NOTE
 *1:A/T
 *2:M/T

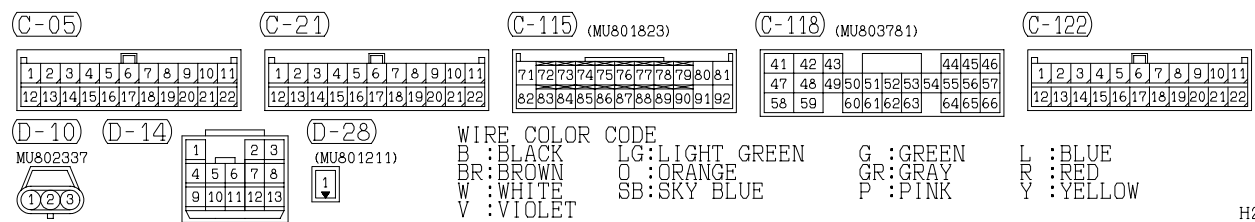

TSB Revision

POWER WINDOWS

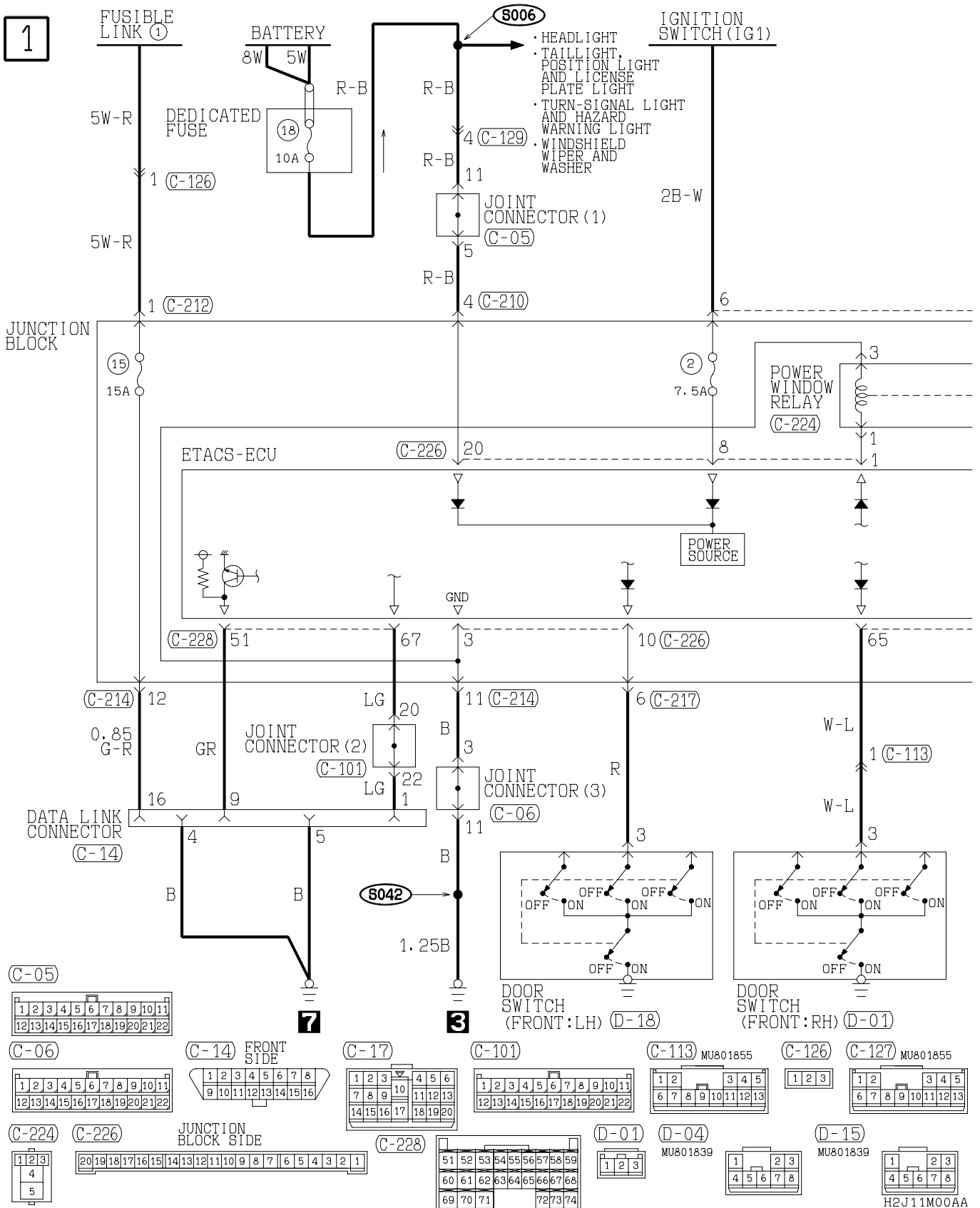

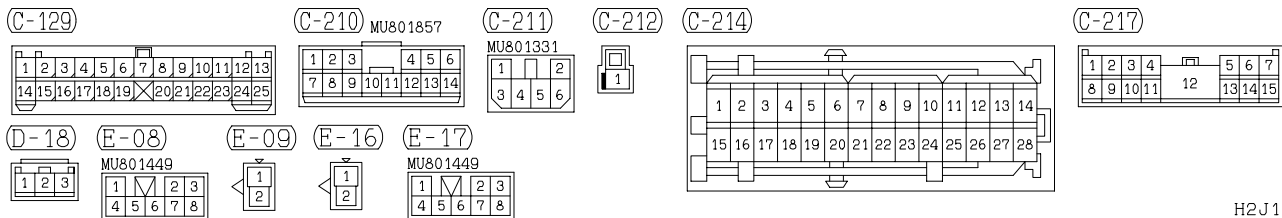
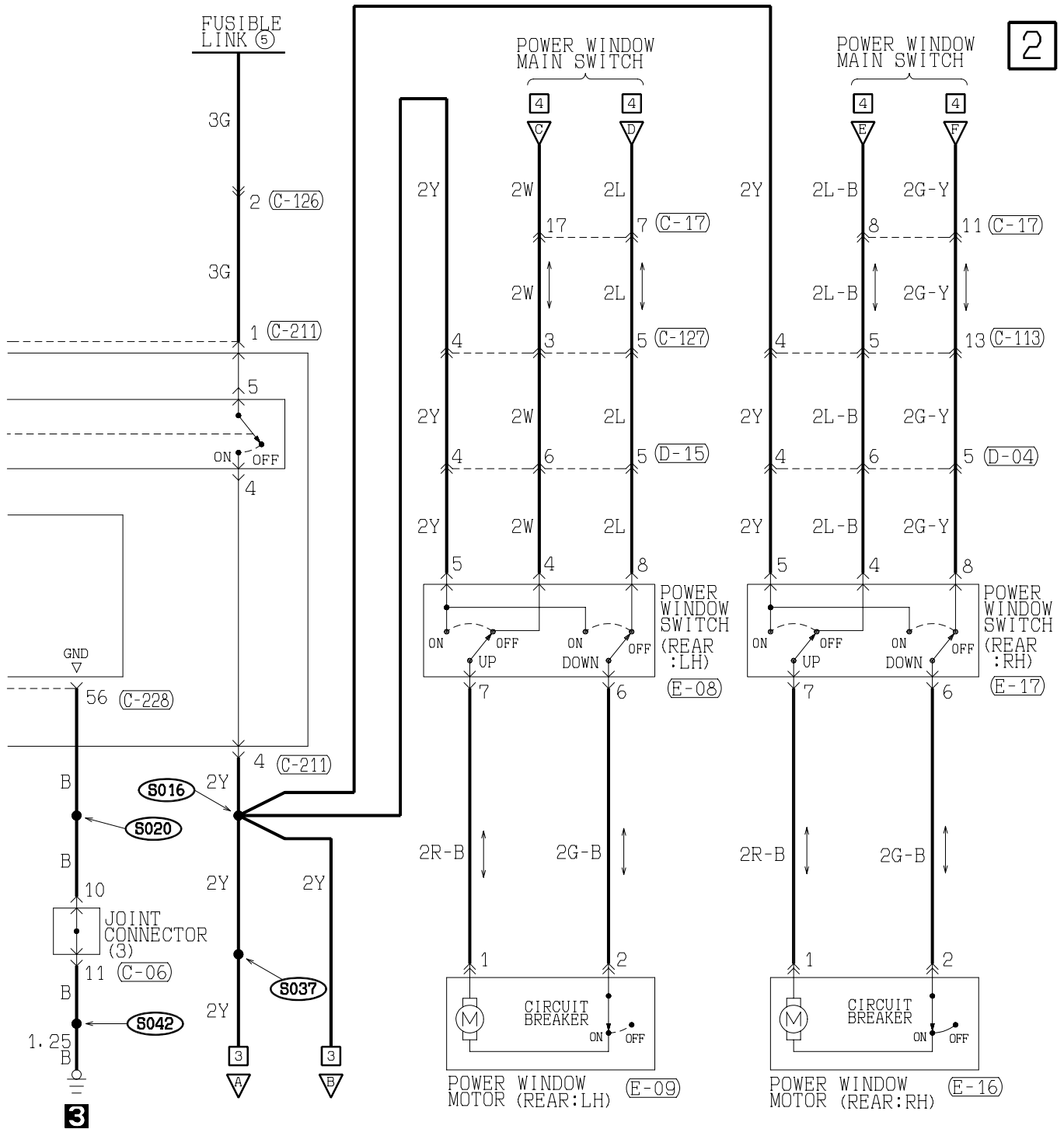

H2J11M00AB

POWER WINDOWS (CONTINUED)

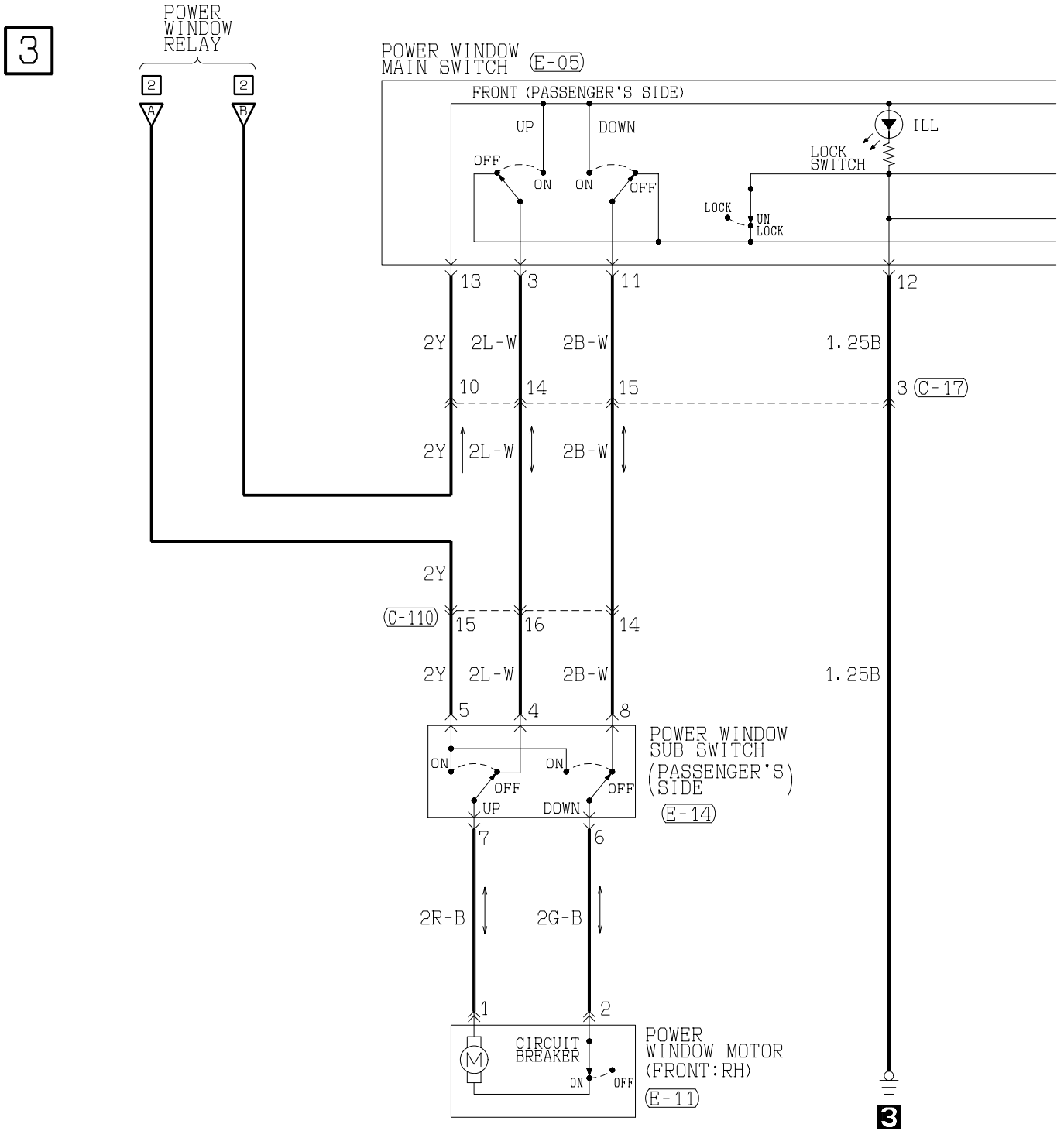

(C-17)

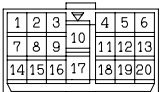

(C-110)

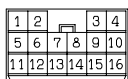

(E-02)



(E-05)

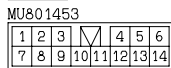

(E-11)



(E-14)

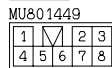

4

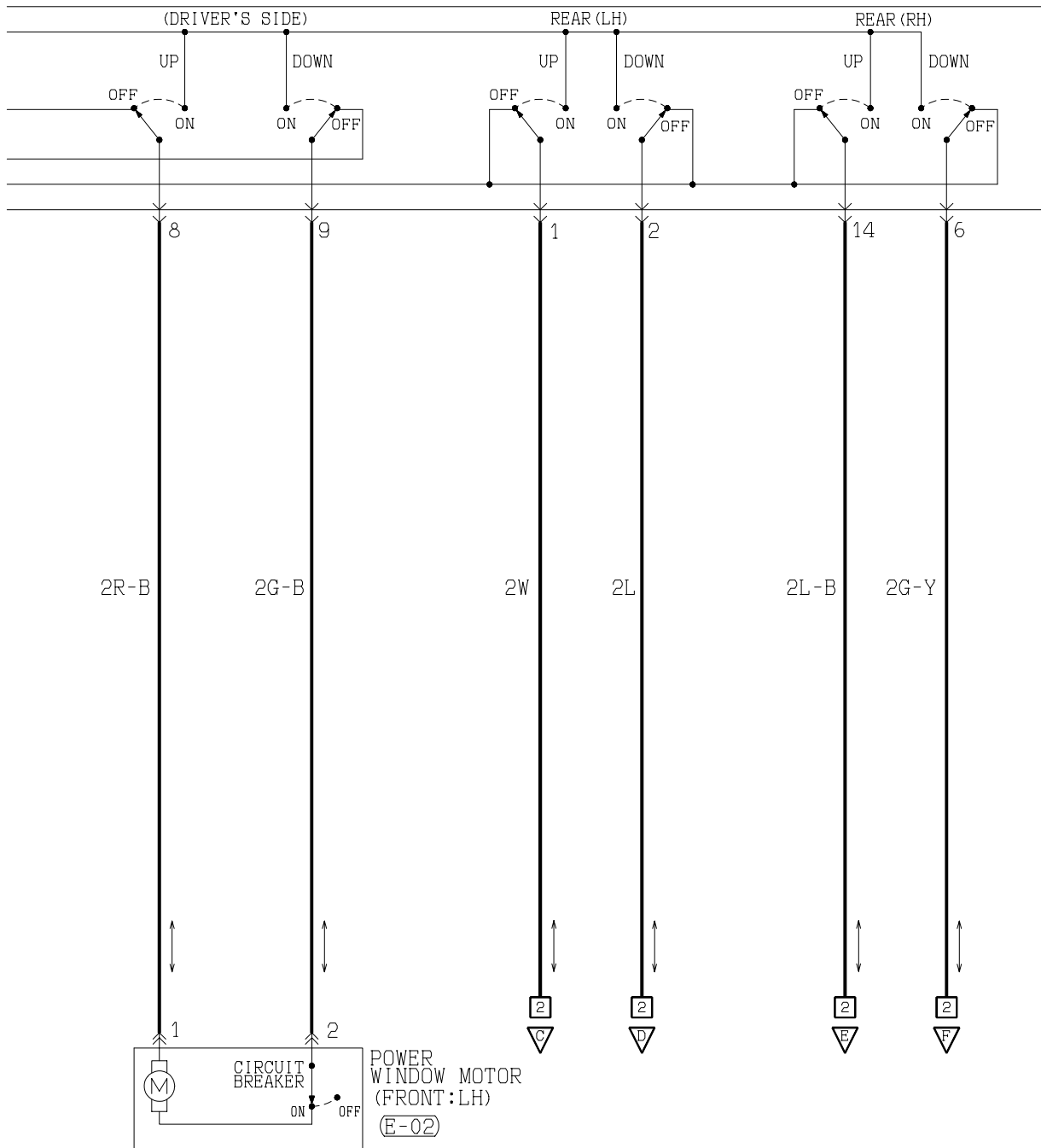

WIRE COLOR CODE
 B : BLACK LG: LIGHT GREEN G : GREEN L : BLUE W : WHITE Y : YELLOW SB: SKY BLUE
 BR: BROWN O : ORANGE GR: GRAY R : RED P : PINK V : VIOLET

H2J11M00BB

TSB Revision

CENTRAL DOOR LOCKING SYSTEM <VEHICLES WITHOUT KEYLESS ENTRY SYSTEM>

M3030004700024

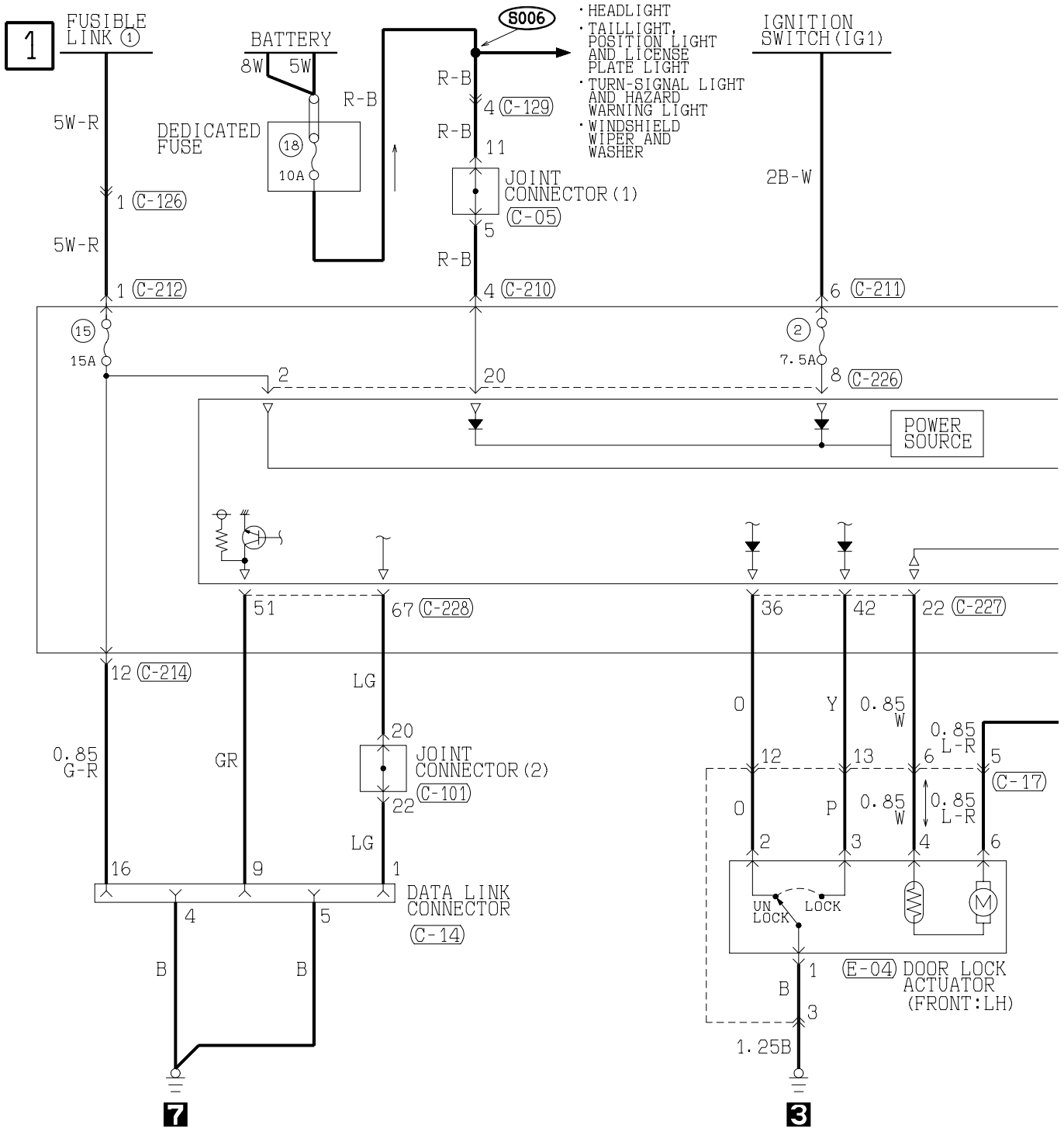

(C-05)

1	2	3	4	5	6	7	8	9	10	11
12	13	14	15	16	17	18	19	20	21	22

(C-14) FRONT SIDE

1	2	3	4	5	6	7	8
9	10	11	12	13	14	15	16

(C-17)

1	2	3	4	5	6
7	8	9	10	11	12
13	14	15	16	17	18
19	20				

(C-101)

1	2	3	4	5	6	7	8	9	10	11
12	13	14	15	16	17	18	19	20	21	22

(C-110)

1	2	3	4
5	6	7	8
9	10	11	12
13	14	15	16

(C-113) MU801855

1	2	3	4	5
6	7	8	9	10
11	12	13		

(C-126)

1	2	3
---	---	---

(C-226) JUNCTION BLOCK SIDE

20	19	18	17	16	15	14	13	12	11	10	9	8	7	6	5	4	3	2	1
----	----	----	----	----	----	----	----	----	----	----	---	---	---	---	---	---	---	---	---

(C-227)

21	22	23	24	25	26	27	28	29
30	31	32	33	34	35	36	37	38
39	40	41		42	43	44		

(C-228)

51	52	53	54	55	56	57	58	59
60	61	62	63	64	65	66	67	68
69	70	71		72	73	74		

(D-04)

1	2	3
4	5	6
7	8	

H2J11M01AA

2

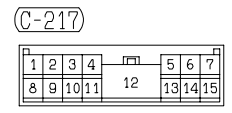
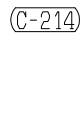
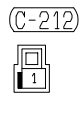
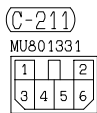
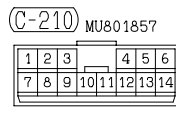
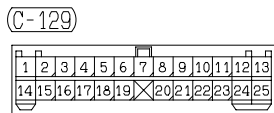
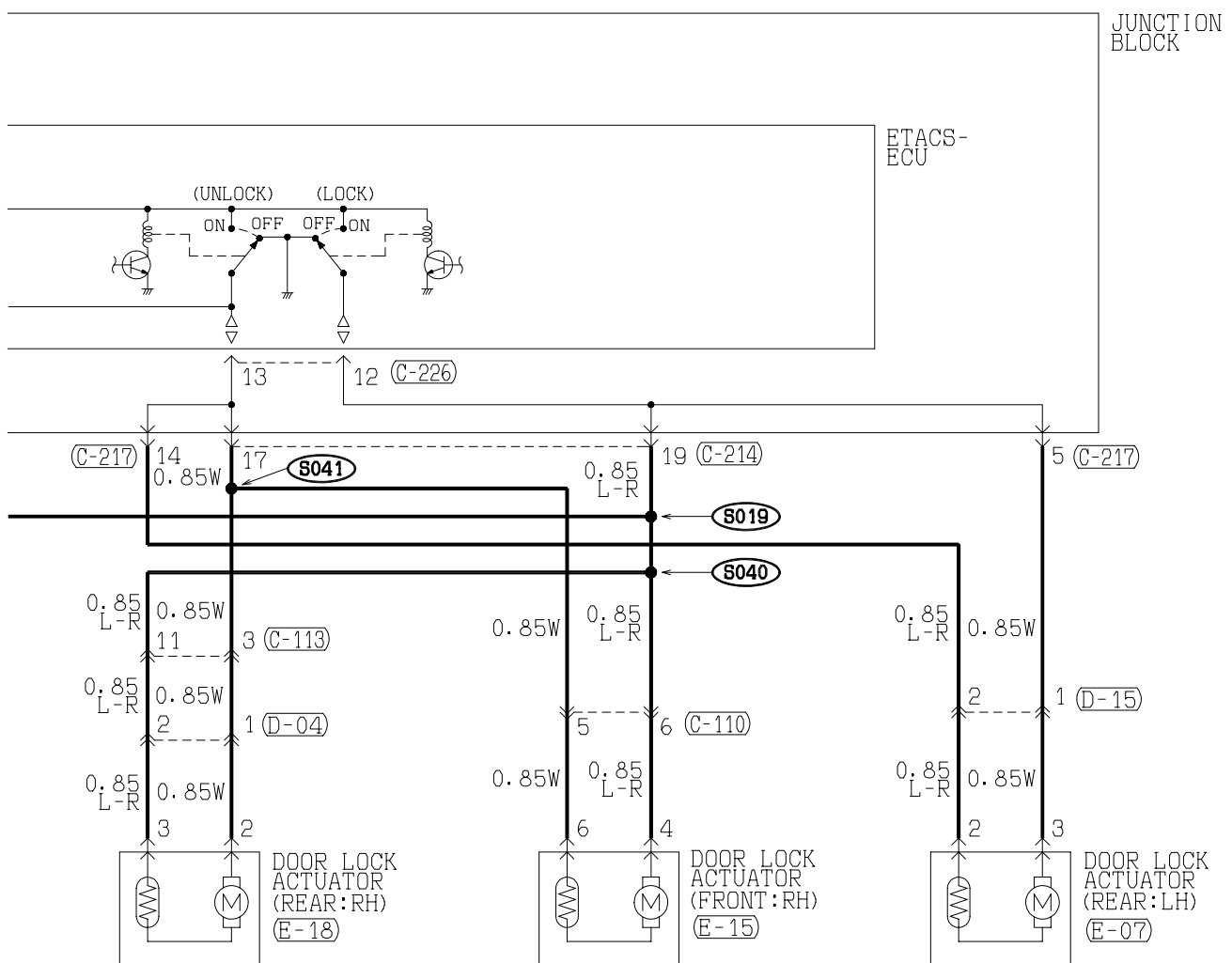

TSB Revision

CENTRAL DOOR LOCKING SYSTEM <VEHICLES WITHOUT KEYLESS ENTRY SYSTEM> (CONTINUED)

3

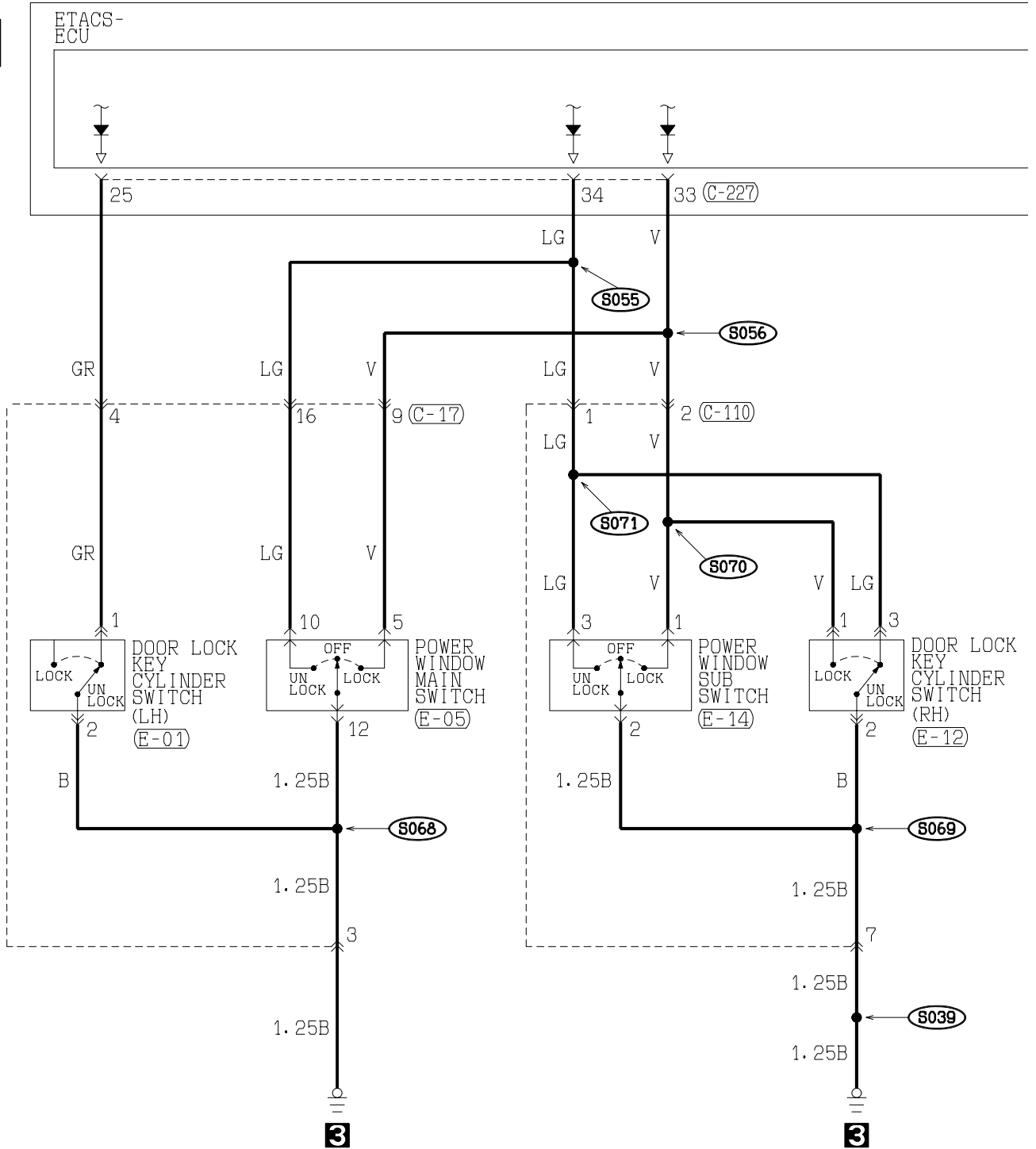

C-06

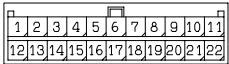

C-17

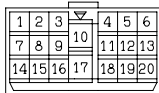

C-110

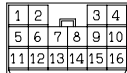

C-113 MU801855

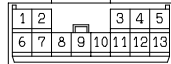

C-214

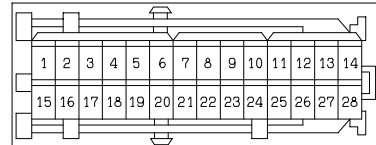

E-01 MU802337



E-05 MU801453

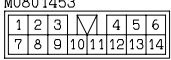

E-12 MU802337



E-14 MU801449

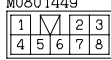

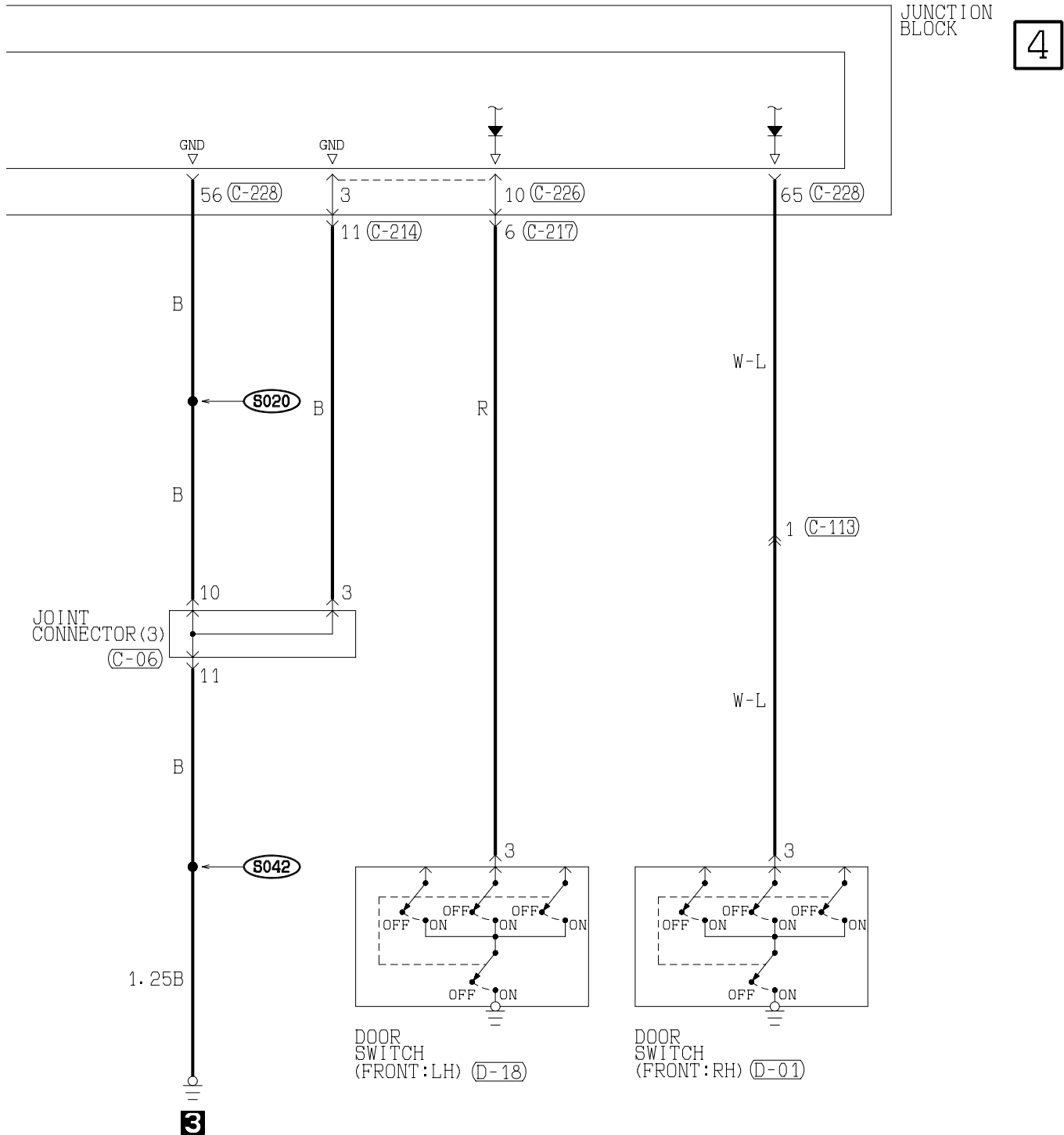

(C-217)

1	2	3	4	5	6	7	
8	9	10	11	12	13	14	15

(C-226) JUNCTION BLOCK SIDE

20	19	18	17	16	15	14	13	12	11	10	9	8	7	6	5	4	3	2	1
----	----	----	----	----	----	----	----	----	----	----	---	---	---	---	---	---	---	---	---

(C-227)

21	22	23	24	25	26	27	28	29
30	31	32	33	34	35	36	37	38
39	40	41	42	43	44			

(C-228)

51	52	53	54	55	56	57	58	59
60	61	62	63	64	65	66	67	68
69	70	71	72	73	74			

(D-01)

1	2	3
---	---	---

(D-18)

1	2	3
---	---	---

WIRE COLOR CODE
 B : BLACK LG: LIGHT GREEN G : GREEN L : BLUE W : WHITE Y : YELLOW SB: SKY BLUE
 BR: BROWN O : ORANGE GR: GRAY R : RED P : PINK V : VIOLET

CENTRAL DOOR LOCKING SYSTEM <VEHICLES WITH KEYLESS ENTRY SYSTEM>

M3030004700035

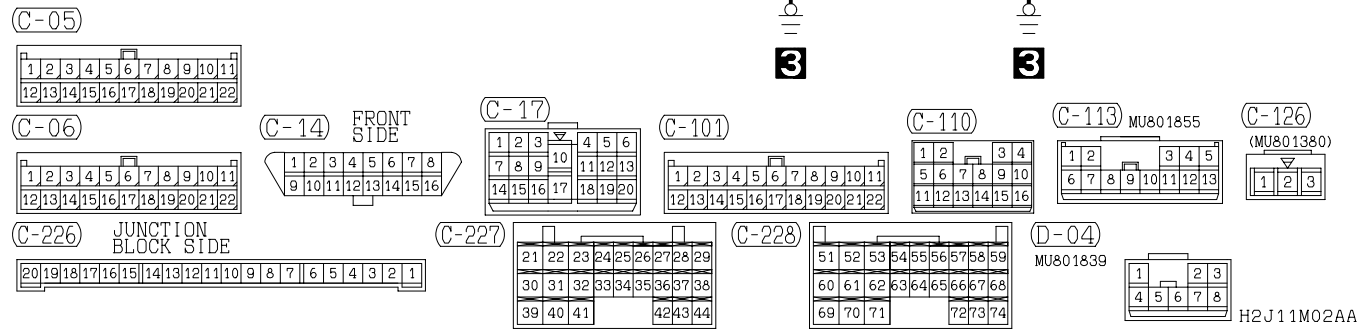
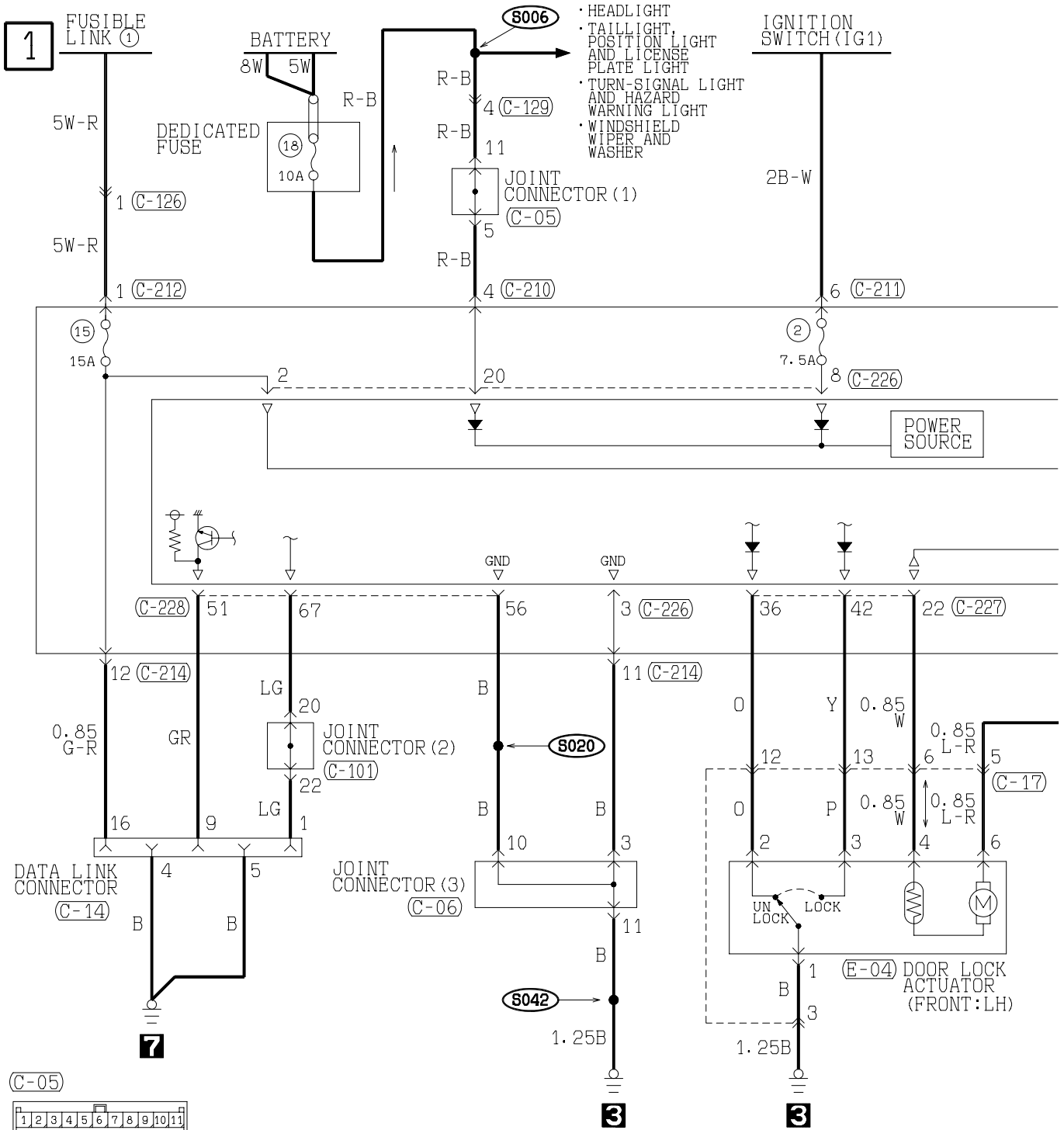

H2J11M02AA

2

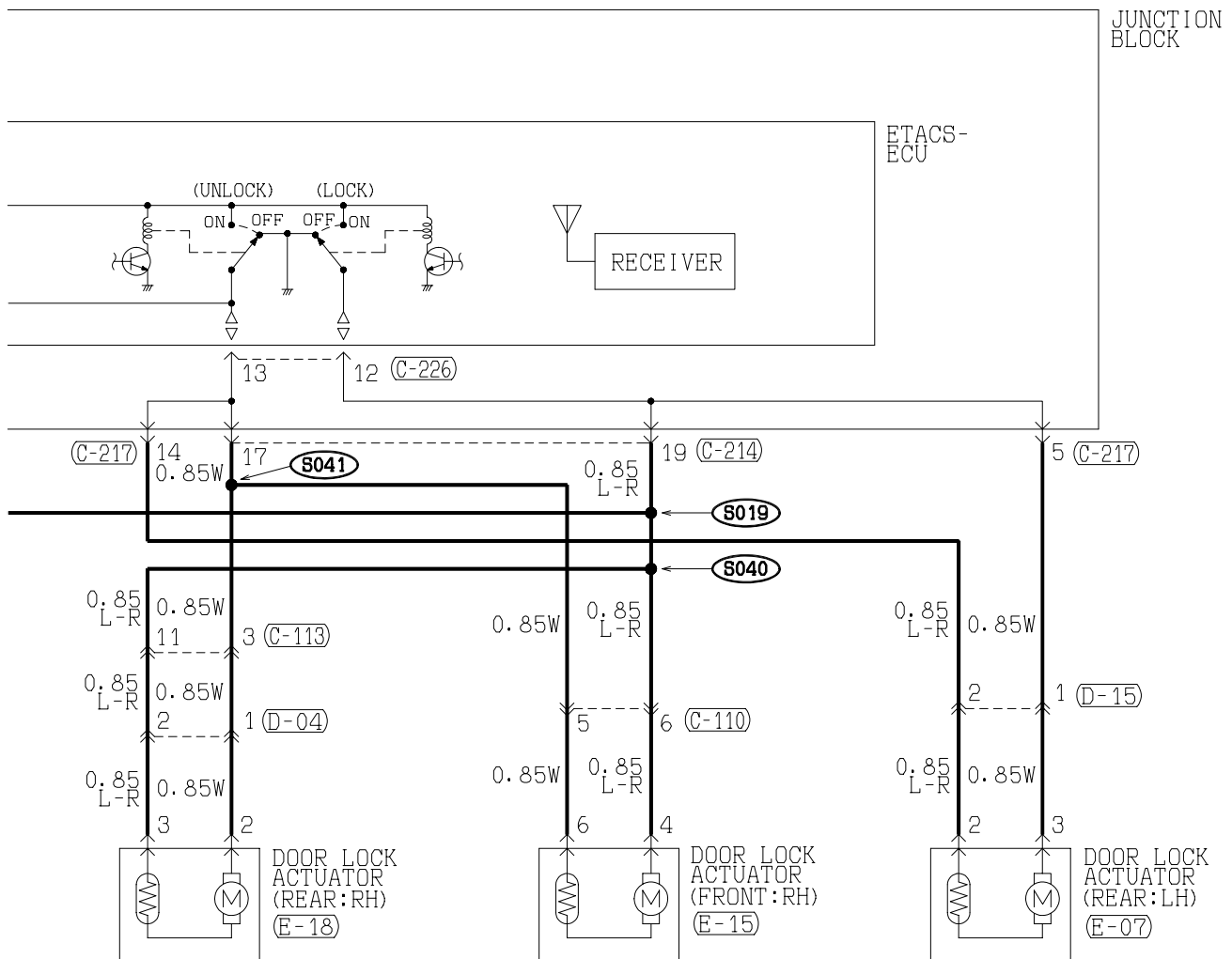
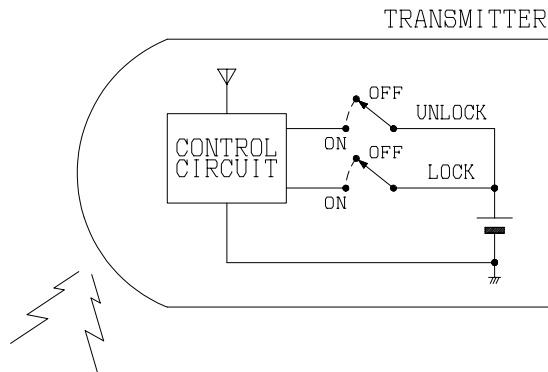

(C-129)

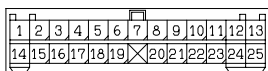

(C-210) MU801857

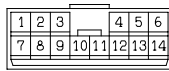

(C-211) MU801331



(C-212)



(C-214)

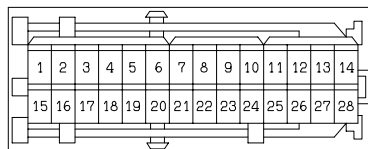

(C-217)

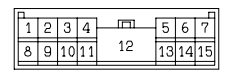

(D-15) MU801839

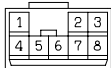

(E-04) MU802341



(E-07) MU802341



(E-15) MU802341



(E-18) MU802341



CENTRAL DOOR LOCKING SYSTEM <VEHICLES WITH KEYLESS ENTRY SYSTEM>
(CONTINUED)

3

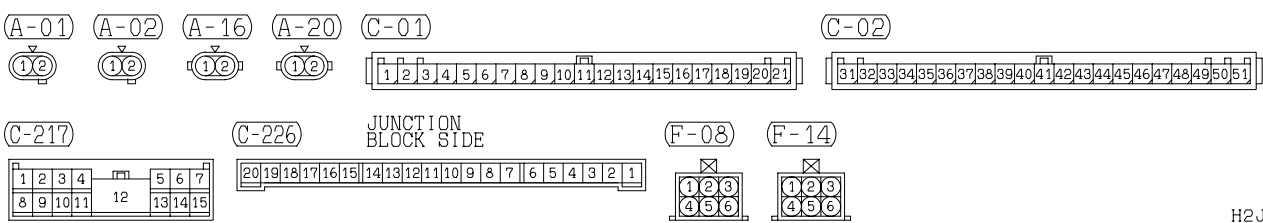
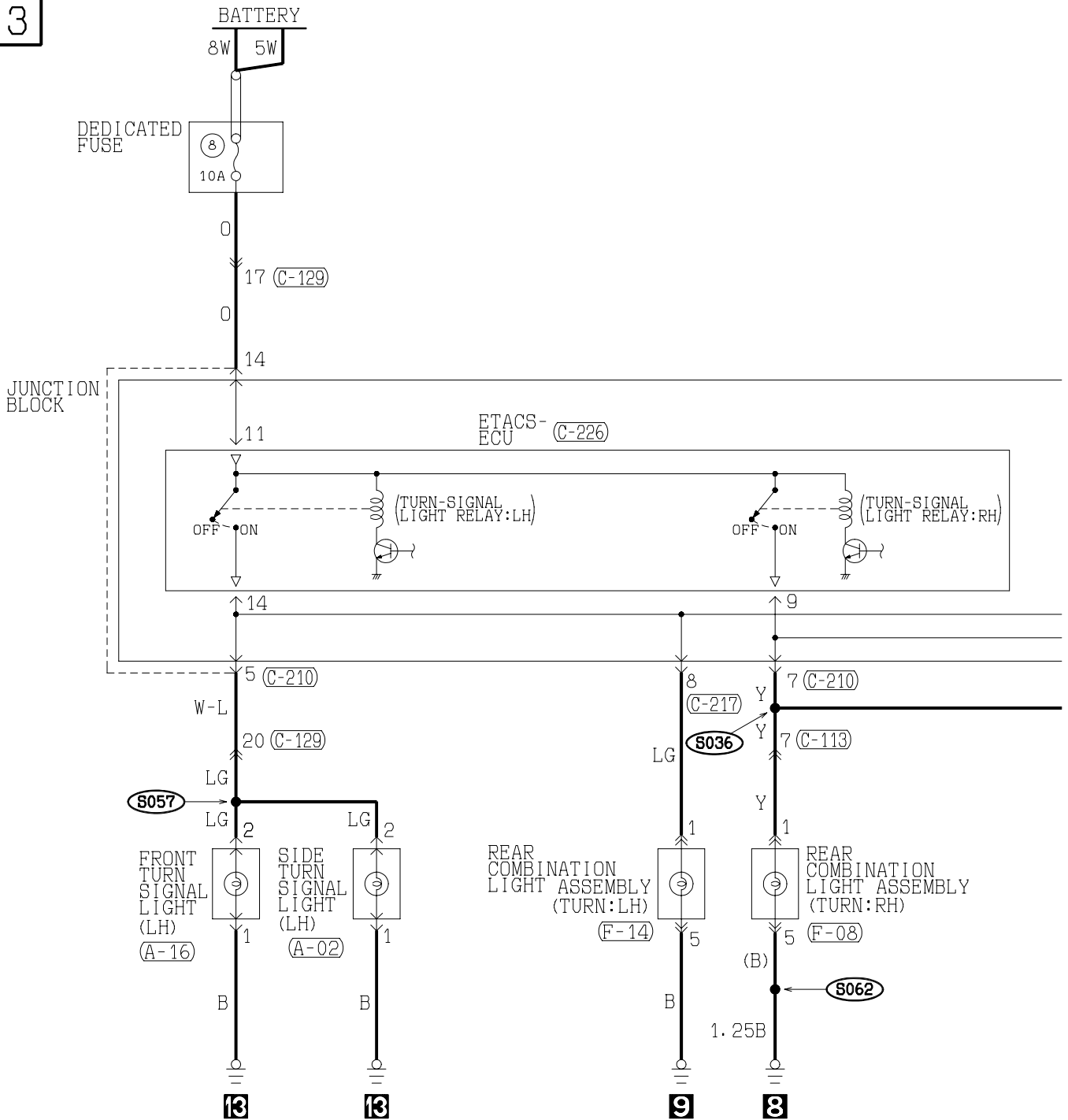

4

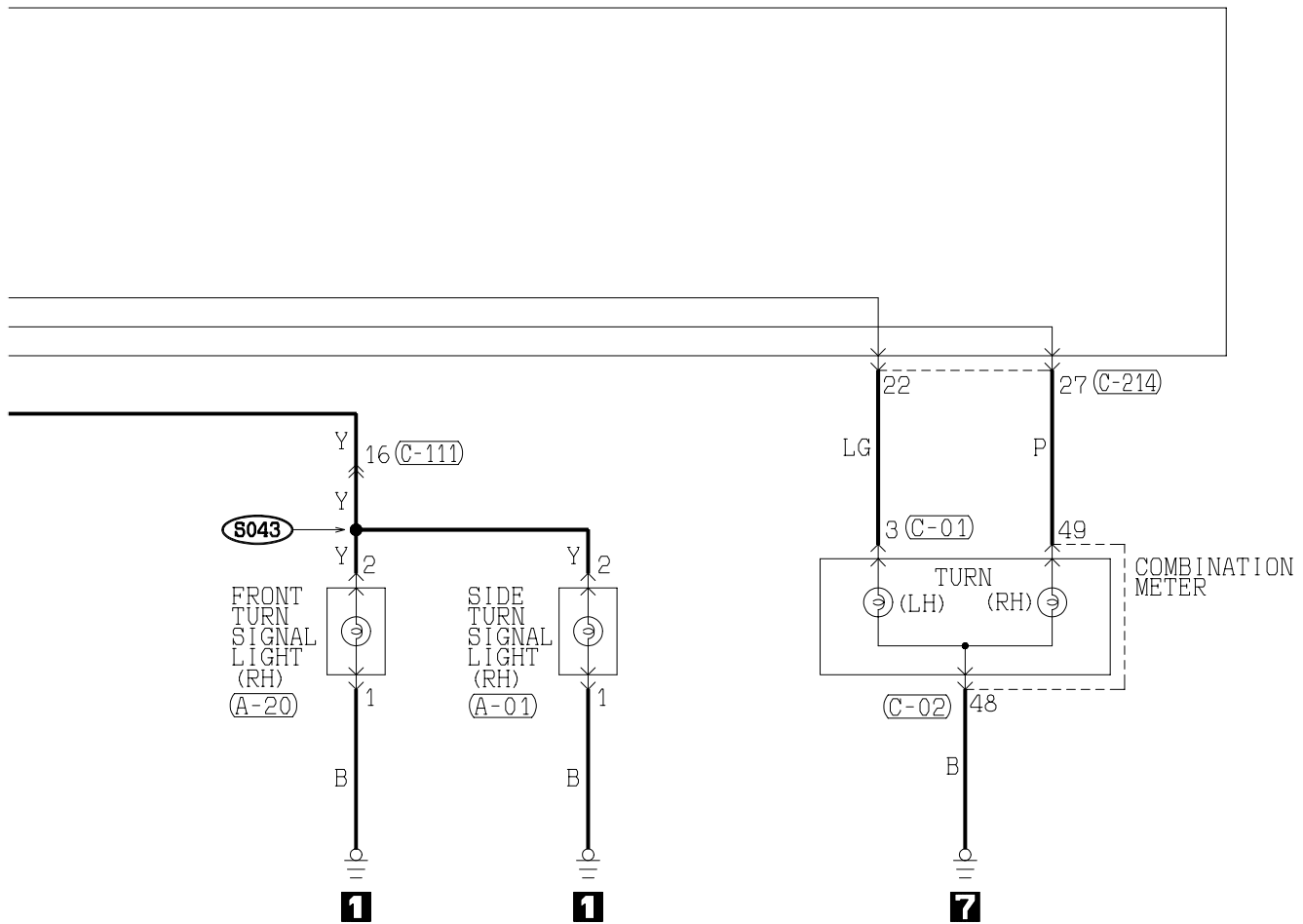

(C-111)

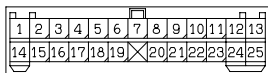

(C-113) MU801855

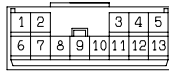

(C-129)

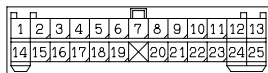

(C-210) MU801857

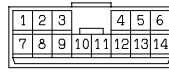

(C-214)

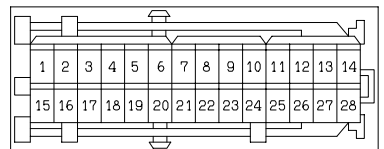

WIRE COLOR CODE
 B : BLACK LG : LIGHT GREEN G : GREEN L : BLUE
 BR : BROWN O : ORANGE GR : GRAY R : RED
 W : WHITE SB : SKY BLUE P : PINK Y : YELLOW
 V : VIOLET

H2J11M02BB

TSB Revision

CENTRAL DOOR LOCKING SYSTEM <VEHICLES WITH KEYLESS ENTRY SYSTEM>
(CONTINUED)

5

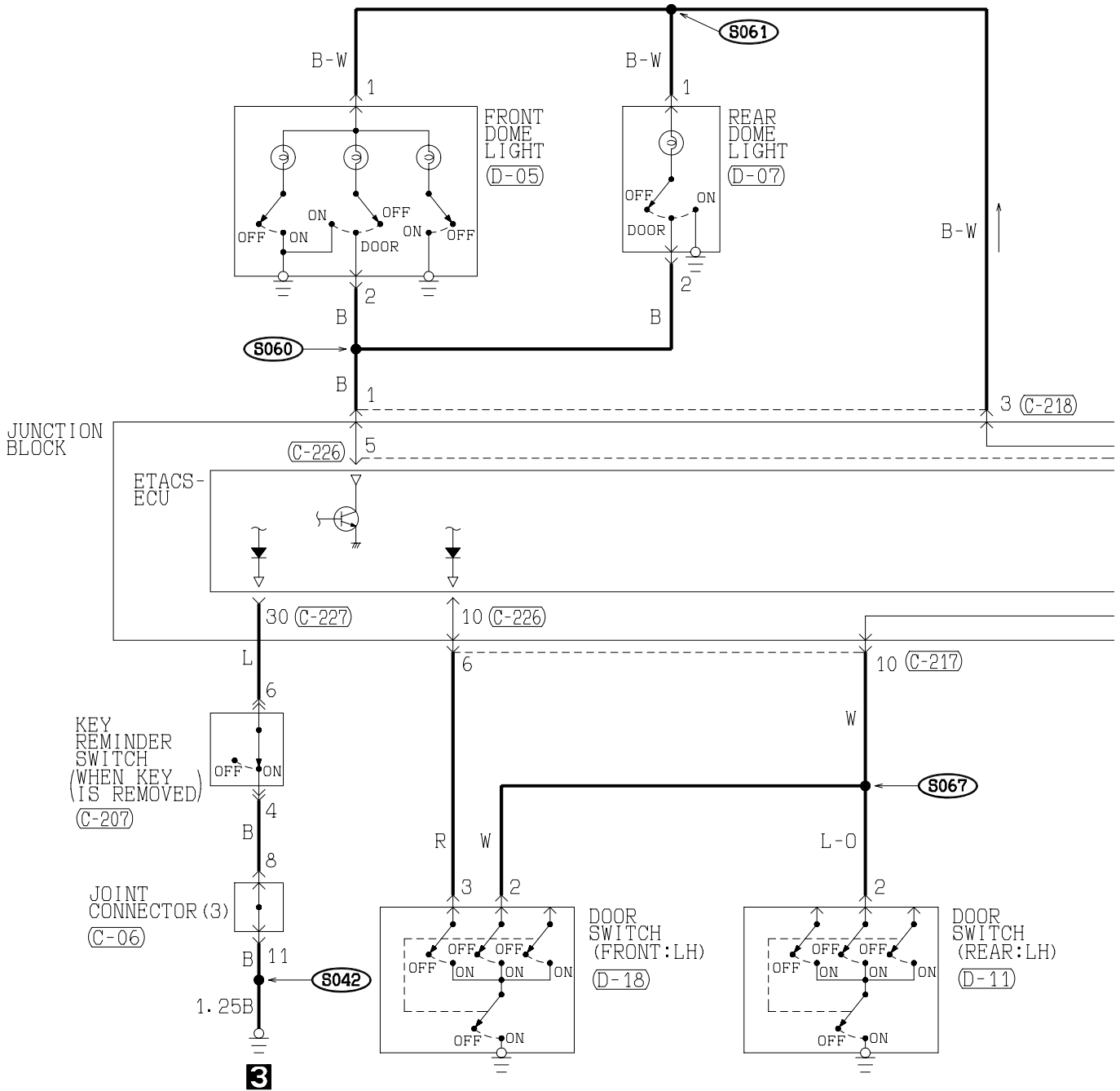

(A-05X)

(C-06)

(C-101)

(C-113) MU801855

(C-129)

(C-207) MU801547

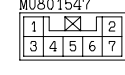
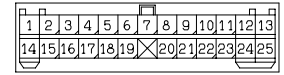
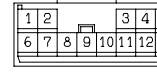
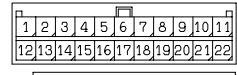
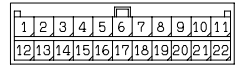

(C-227)

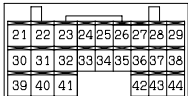

(C-228)

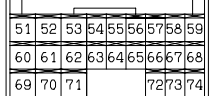

(D-01)

(D-05)

(D-07)

(D-08)

(D-11)

(D-18)

(F-02)



6

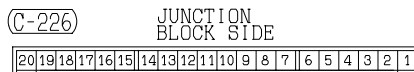
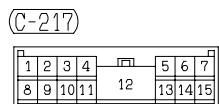
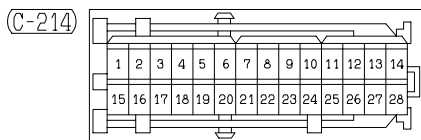
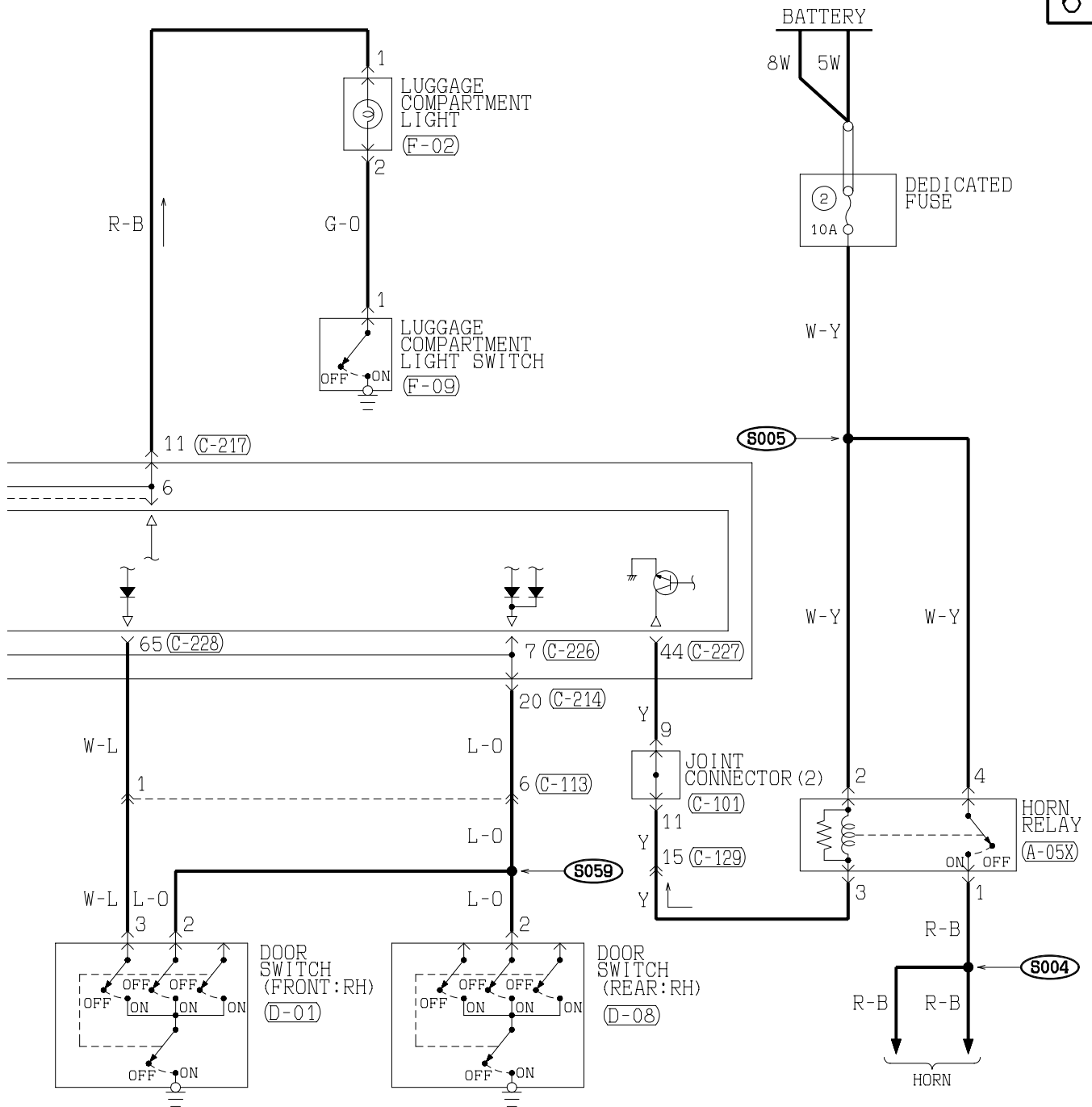

(F-09) (MU801211) **WIRE COLOR CODE**
 B : BLACK LG : LIGHT GREEN G : GREEN L : BLUE W : WHITE Y : YELLOW SB : SKY BLUE
 BR : BROWN O : ORANGE GR : GRAY R : RED P : PINK V : VIOLET

H2J11M02CB

CENTRAL DOOR LOCKING SYSTEM <VEHICLES WITH KEYLESS ENTRY SYSTEM>
(CONTINUED)

7

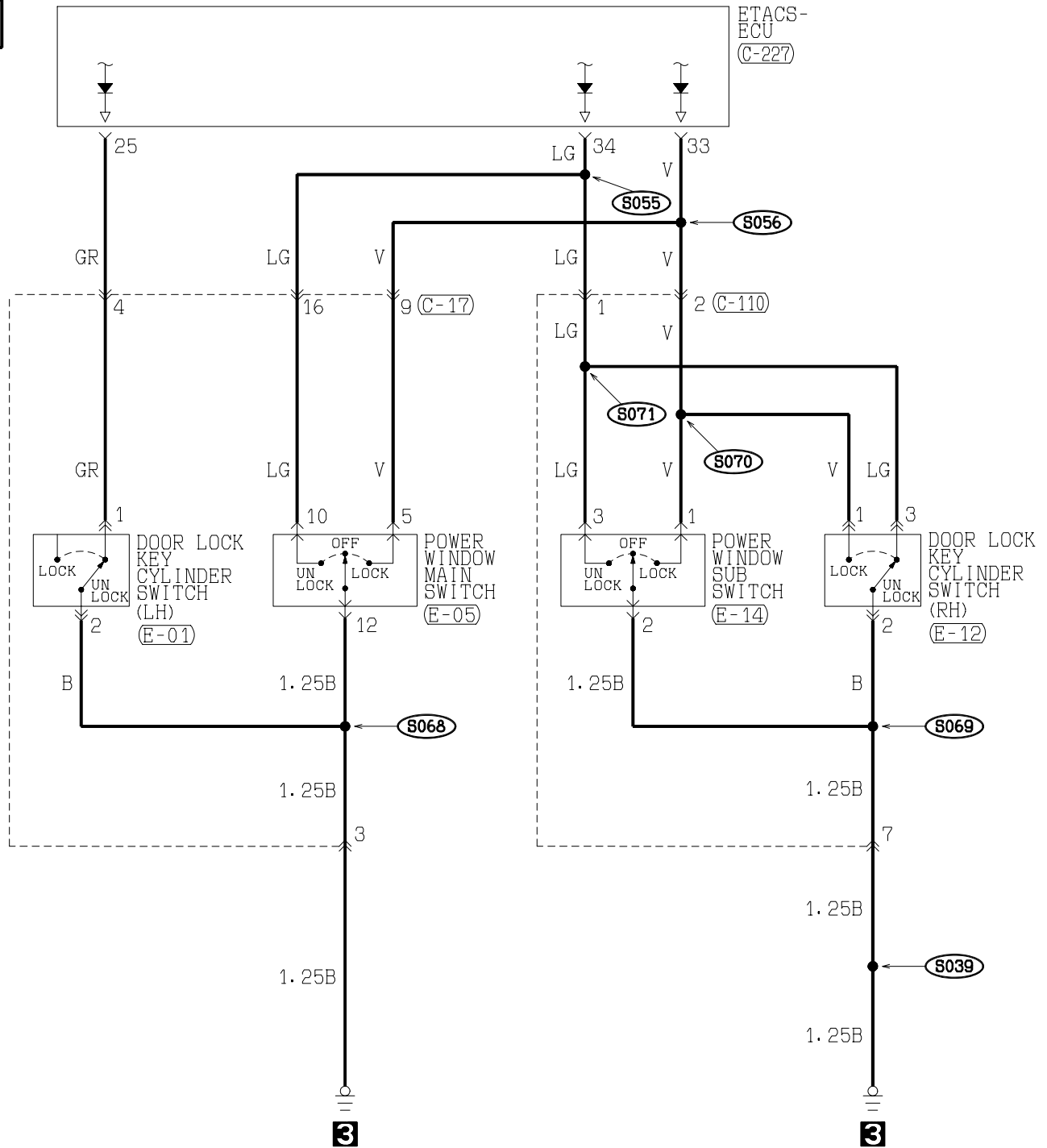

(C-17)

1	2	3	4	5	6
7	8	9	10	11	12
13	14	15	16	17	18
19	20				

(C-110)

1	2	3	4
5	6	7	8
9	10	11	12
13	14	15	16

(C-227)

21	22	23	24	25	26	27	28	29
30	31	32	33	34	35	36	37	38
39	40	41	42	43	44			

(E-01) MU802337

1	2	3
---	---	---

(E-05) MU801453

1	2	3	4	5	6
7	8	9	10	11	12
13	14				

(E-12) MU802337

1	2	3
---	---	---

(E-14) MU801449

1	2	3
4	5	6
7	8	

WIRE COLOR CODE
 B : BLACK LG : LIGHT GREEN G : GREEN L : BLUE
 BR : BROWN O : ORANGE GR : GRAY R : RED
 W : WHITE SB : SKY BLUE P : PINK Y : YELLOW
 V : VIOLET

H2J11M02DA

TSB Revision

NOTES

AIR CONDITIONING SYSTEM

M3030005500023

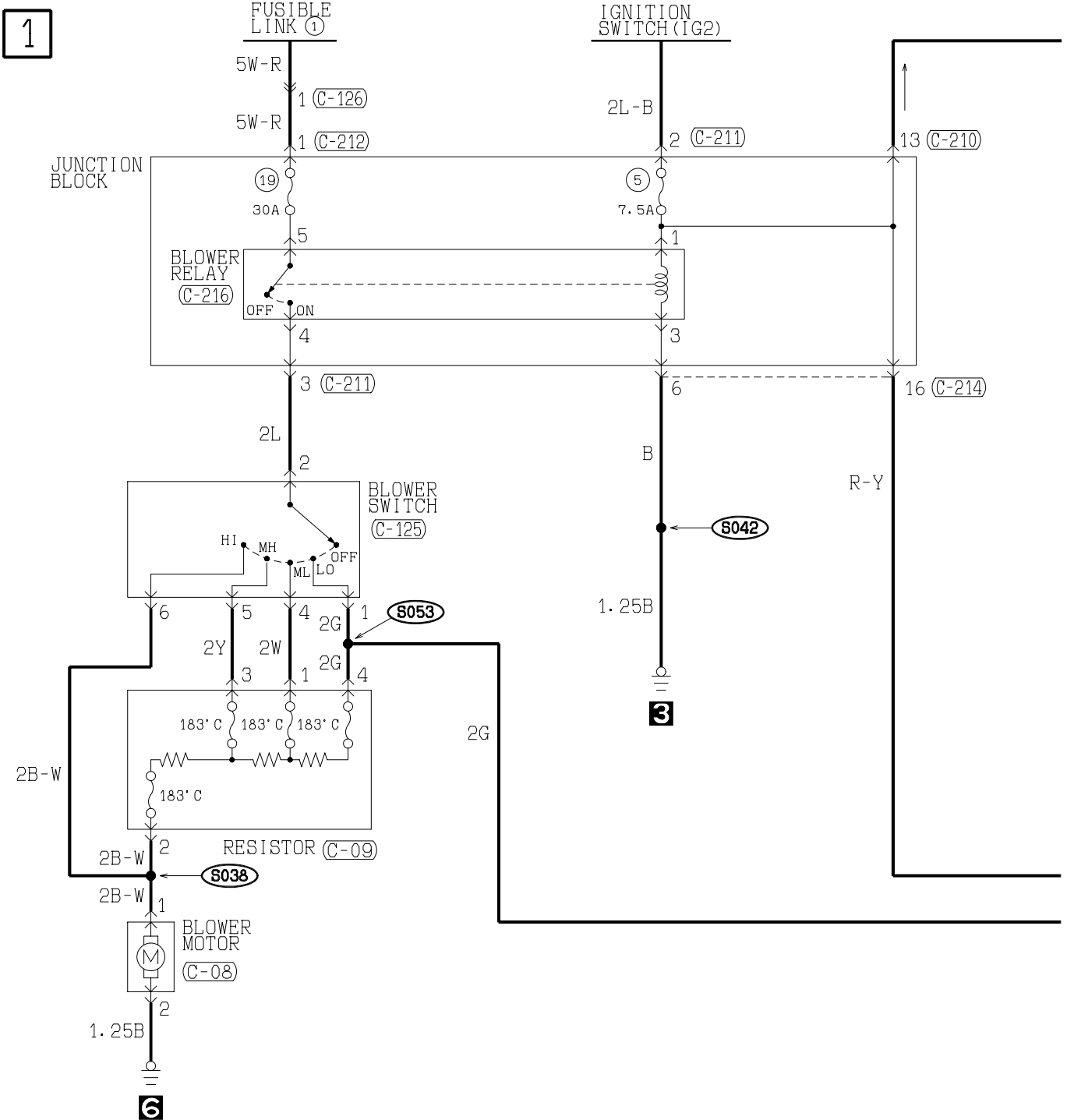

(C-05)

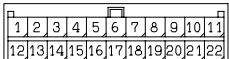

(C-06)

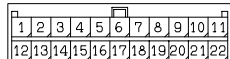

(C-07)



(C-08)



(C-09)



(C-129)

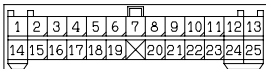

(C-210) MU801857

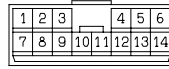

(C-211)

MU801331



(C-212)



(C-214)

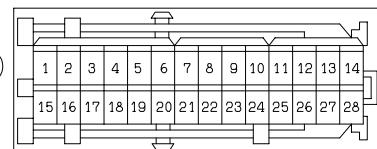

H2J12M00AA

2

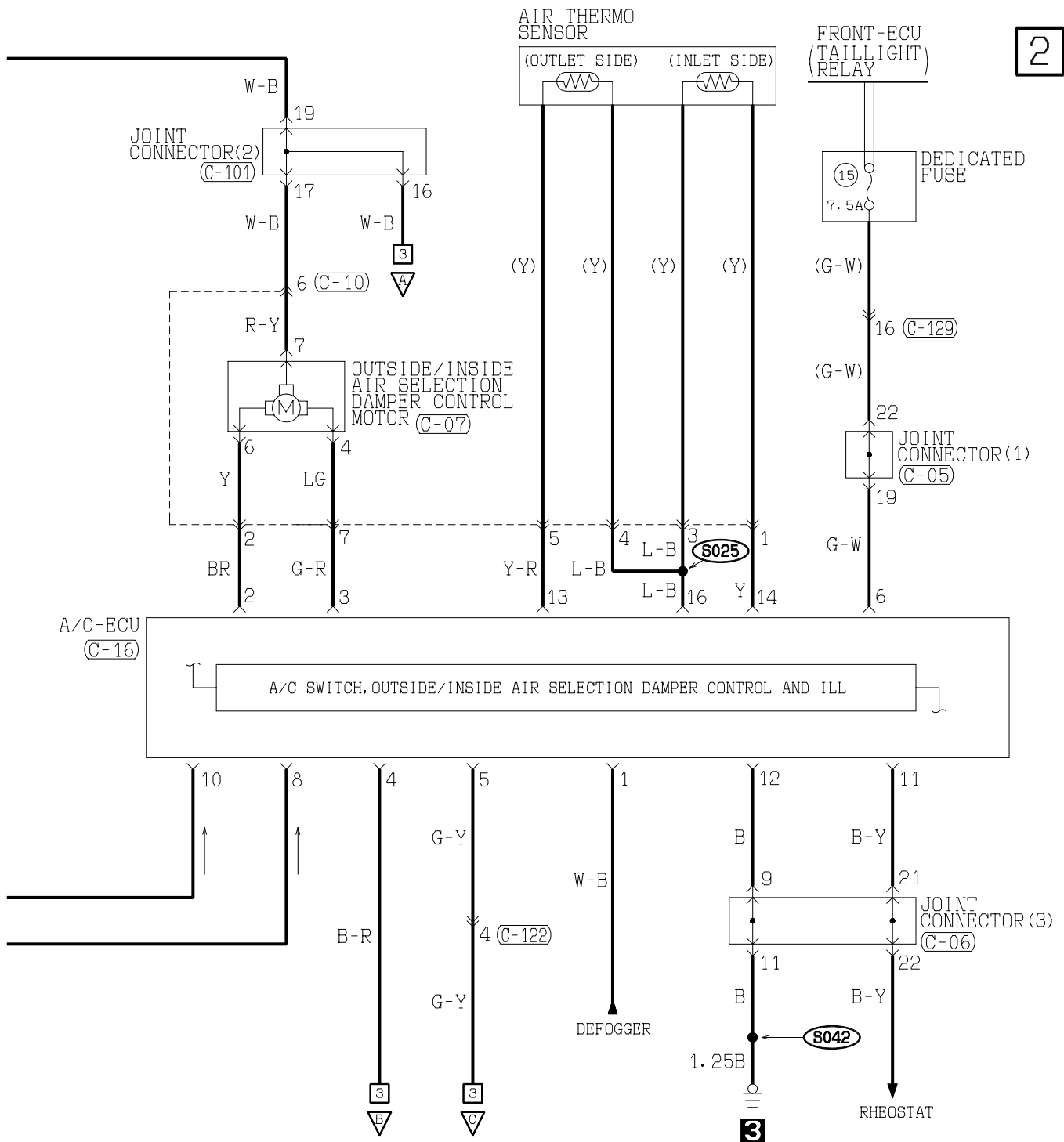

(C-10)
MU801837

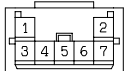

(C-16) (MU801584)

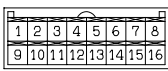

(C-101)

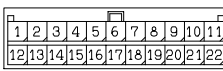

(C-122)

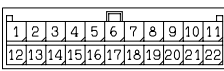

(C-125)



(C-126)
(MU801380)



(C-216)



WIRE COLOR CODE
B: BLACK LG: LIGHT GREEN
BR: BROWN O: ORANGE

G: GREEN GR: GRAY

L: BLUE R: RED

W: WHITE P: PINK

Y: YELLOW V: VIOLET

SB: SKY BLUE

H2J12M00AB

AIR CONDITIONING SYSTEM (CONTINUED)

3

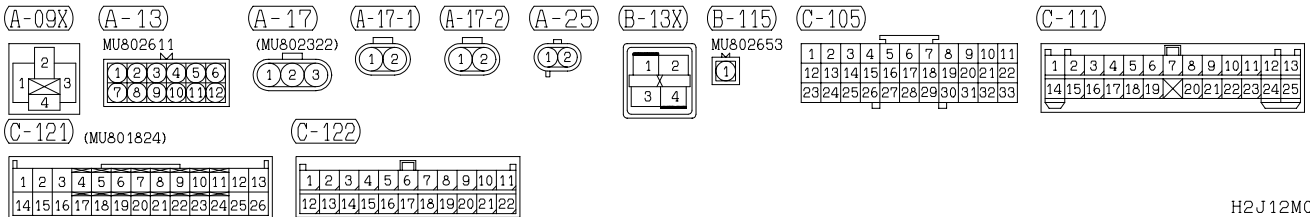
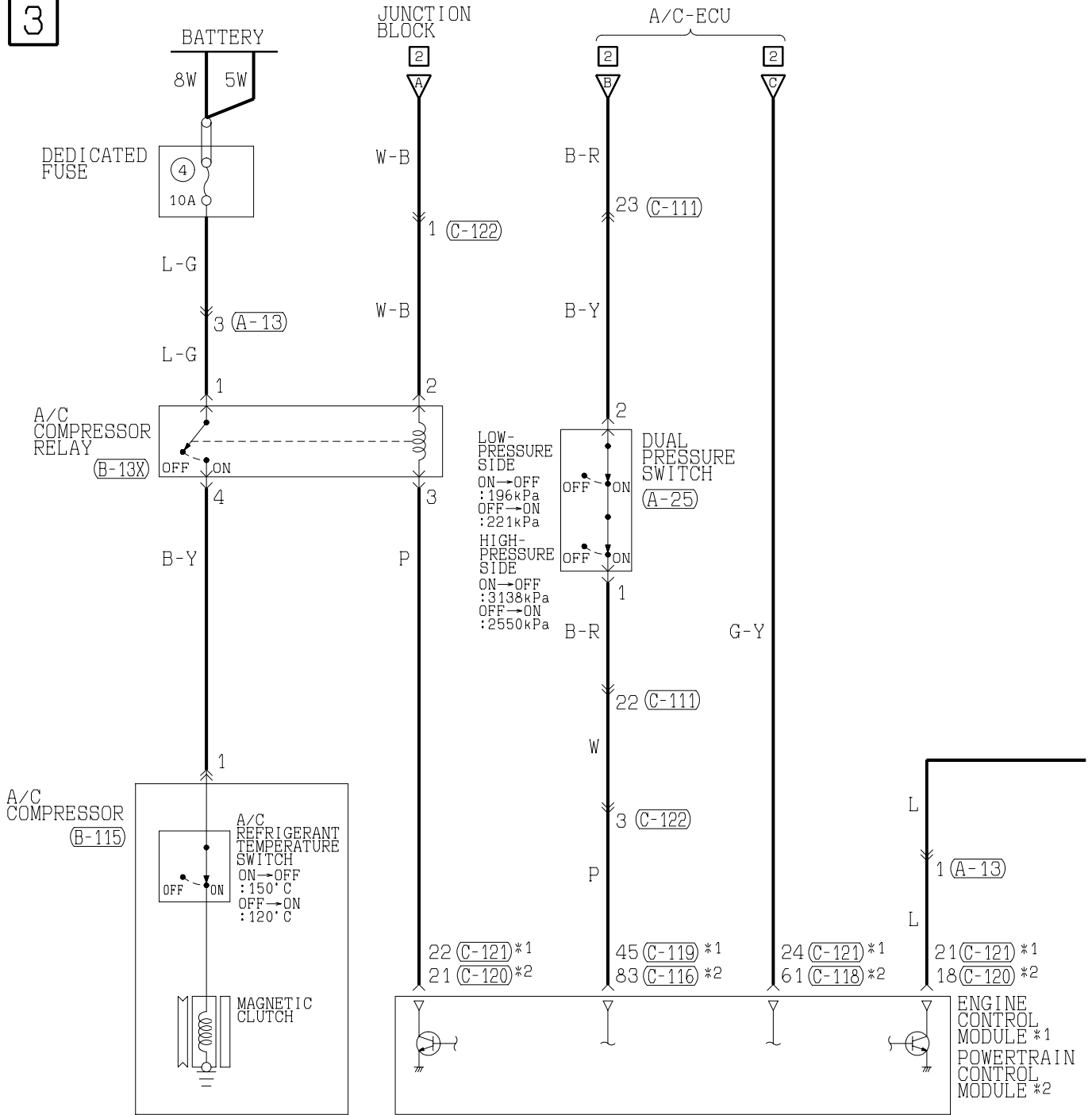

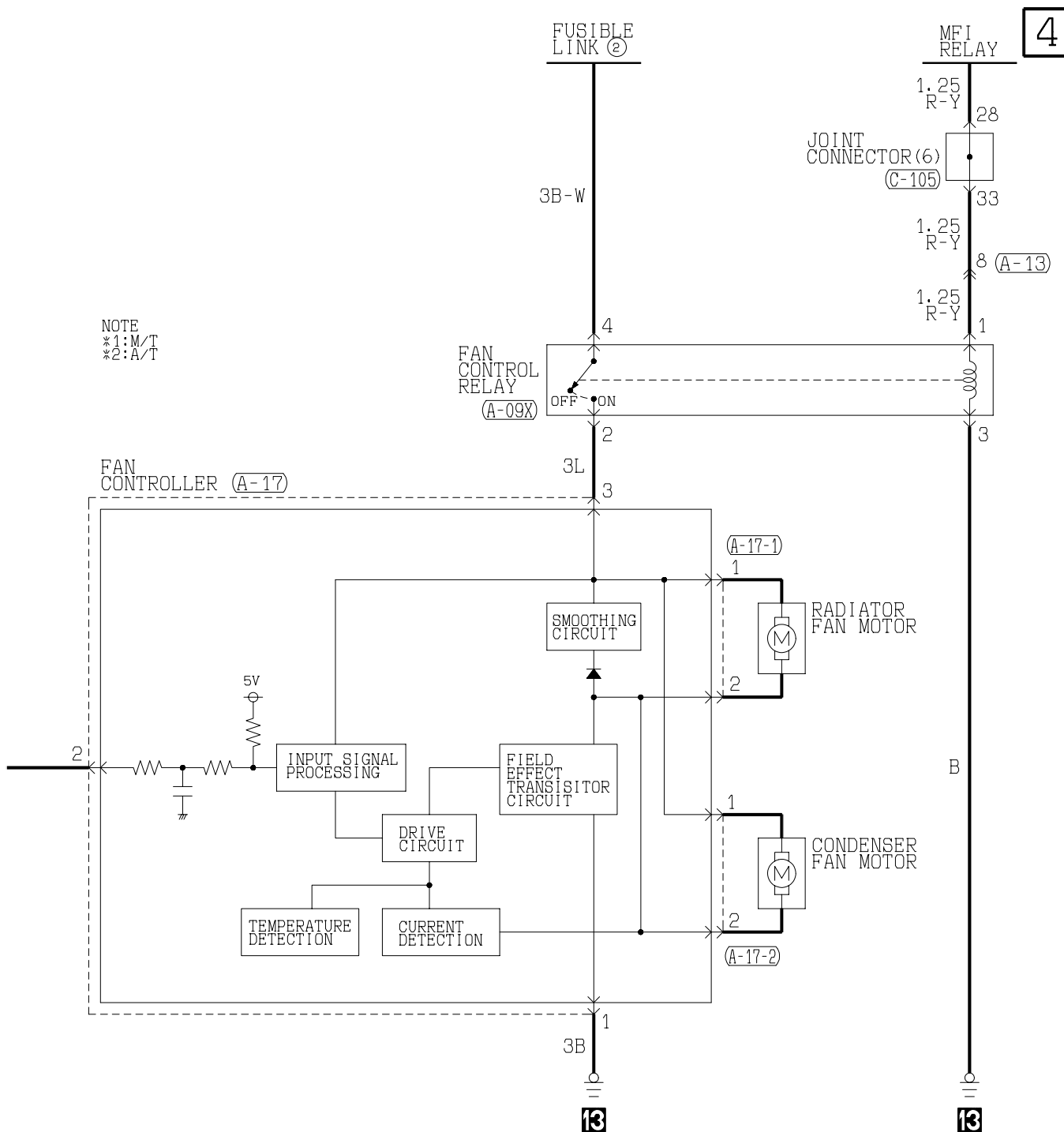

(C-116) (MU803782)

71	72	73	74			75	76	77			
78	79	80	81	82	83	84	85	86	87	88	89
90	91	92	93	94	95	96	97	98			

(C-118) (MU803781)

41	42	43				44	45	46		
47	48	49	50	51	52	53	54	55	56	57
58	59	60	61	62	63	64	65	66		

(C-119) (MU801822)

31	32	33	34	35	36	37	38
39	40	41	42	43	44	45	46

(C-120) (MU803784)

1	2	3	4			5	6	7	8					
9	10	11	12	13	14	15	16	17	18	19	20	21	22	23
24	25	26	27	28	29	30	31	32	33	34	35			

WINDSHIELD WIPER AND WASHER

1

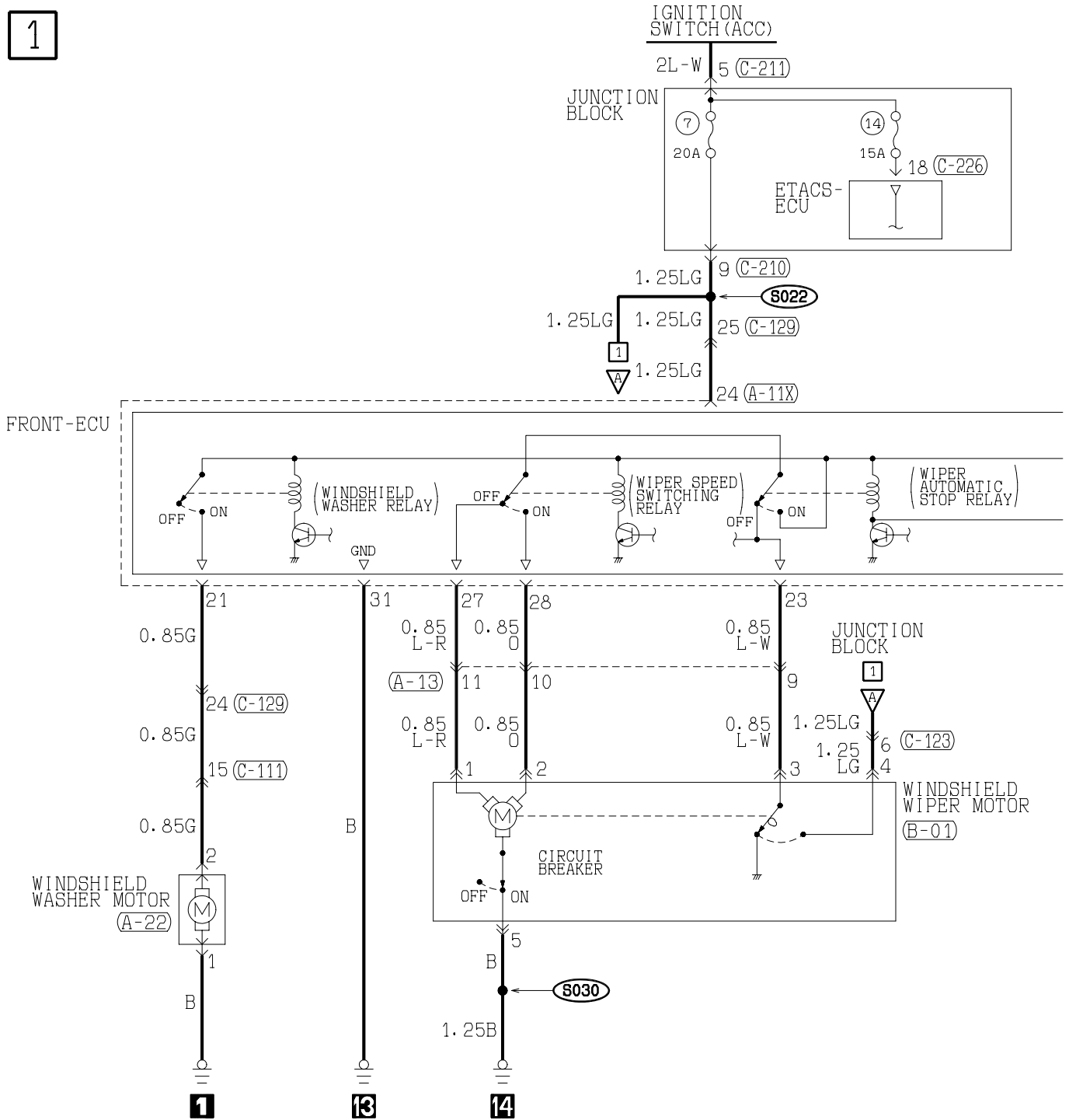

(A-10X)

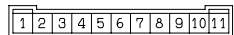

(A-11X)

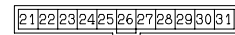

(A-13)

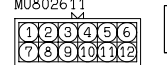

(A-22)



(B-01)



(C-05)

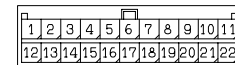

(C-06)

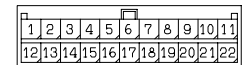

(C-123)

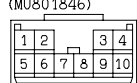

(C-129)

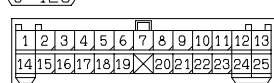

(C-206)

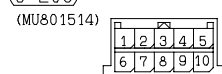

(C-206-1)

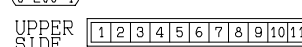

(C-206-2)

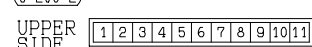

2

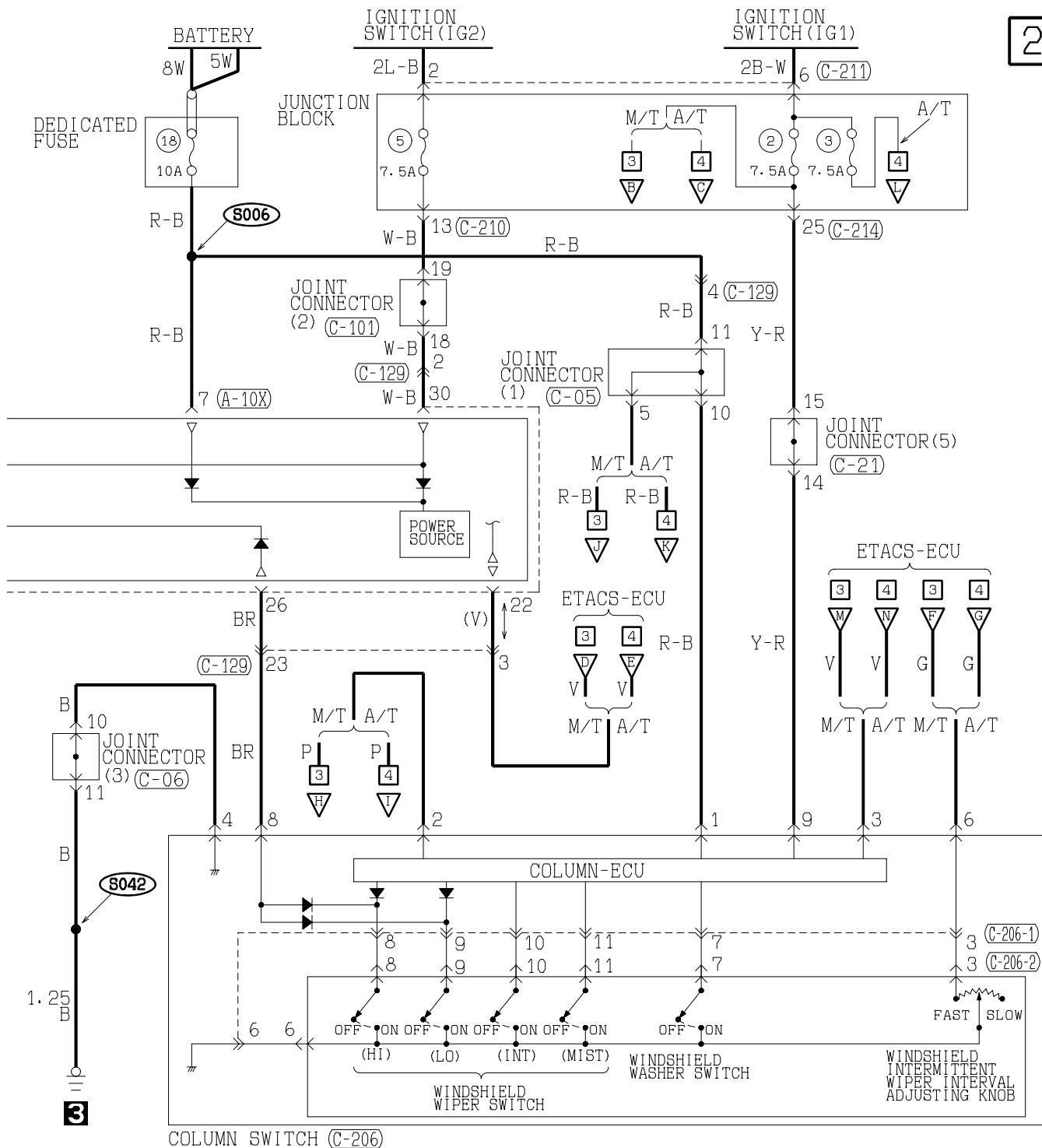

(C-21)

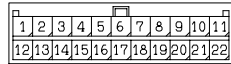

(C-101)

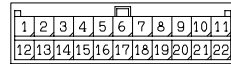

(C-210) MU801857

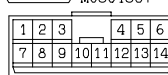

(C-211) MU801331



(C-214)

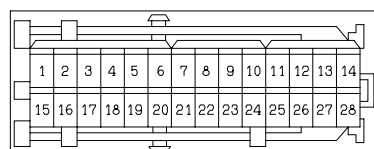

(C-111)

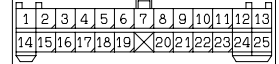

(C-226) JUNCTION BLOCK SIDE

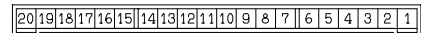

WINDSHIELD WIPER AND WASHER (CONTINUED)

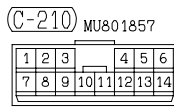
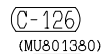
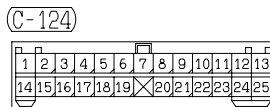
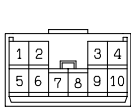
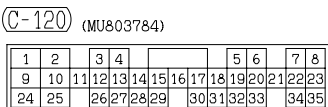
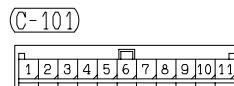
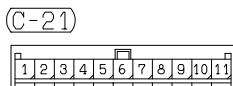
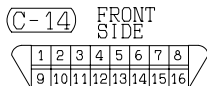
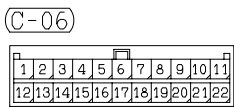
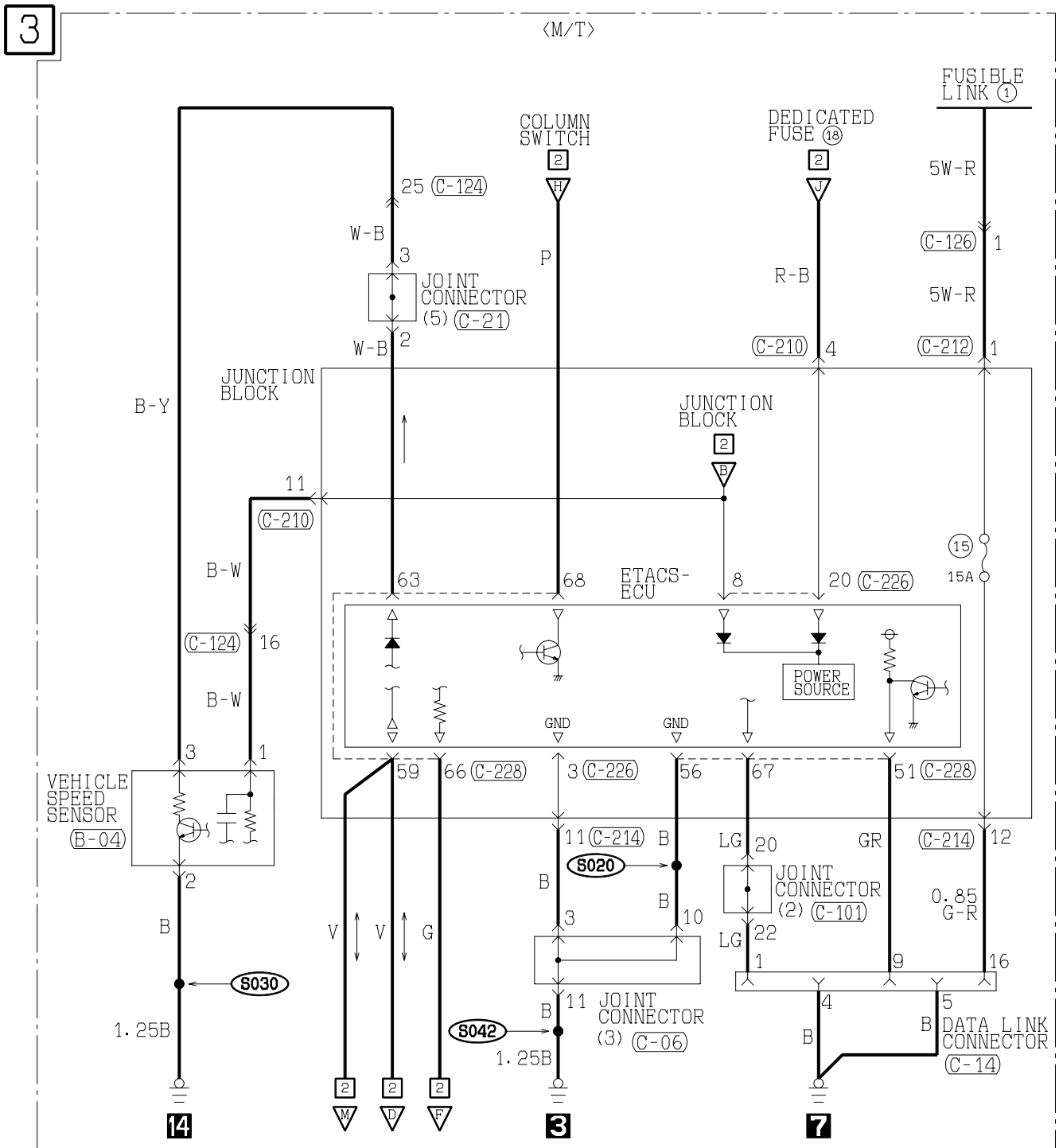

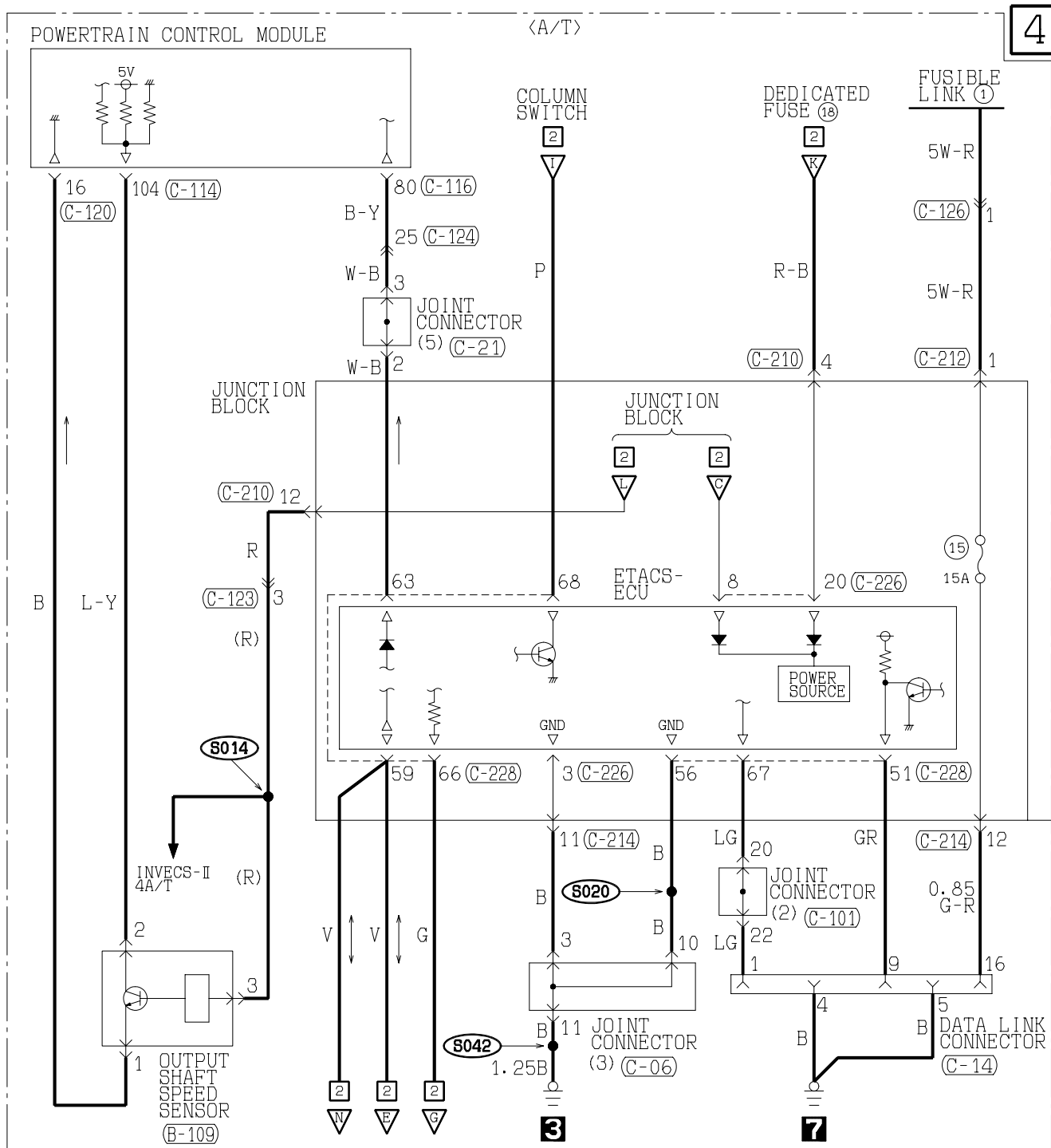

(C-114) (MU803783)

(C-116) (MU803782)

101	102	103	104	105	106	107
108	109	110	111	112	113	114
115	116	117	118	119	120	
121	122	123	124	125	126	127
128	129	130				

71	72	73	74	75	76	77
78	79	80	81	82	83	84
85	86	87	88	89		
90	91	92	93	94	95	96
97	98					

(C-214)

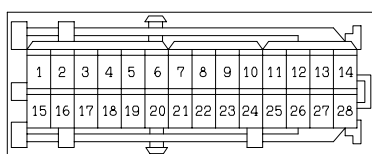

(C-226) JUNCTION BLOCK SIDE

20	19	18	17	16	15	14	13	12	11	10	9	8	7	6	5	4	3	2	1
----	----	----	----	----	----	----	----	----	----	----	---	---	---	---	---	---	---	---	---

(C-228)

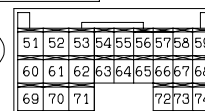

REAR WIPER AND WASHER

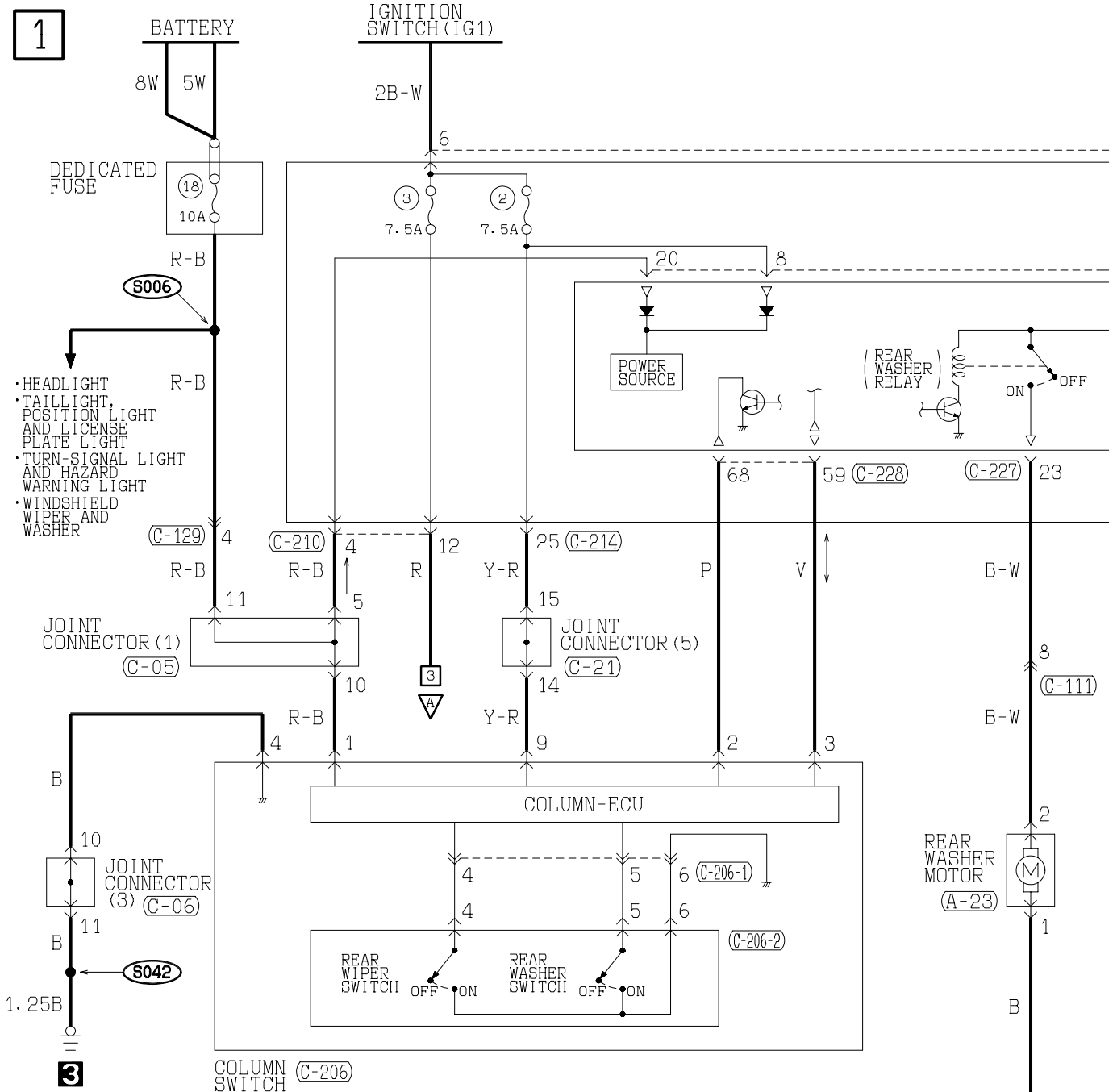

(A-23) (C-05)



(C-06)



(C-14) FRONT SIDE

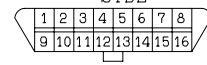

(C-21)

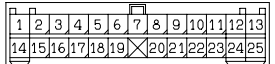

(C-101)

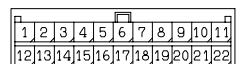

(C-111)

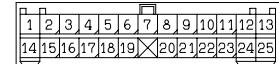

(C-210) MU801857

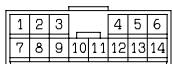

(C-211) MU801331

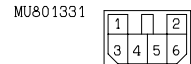

(C-212)



(C-214)

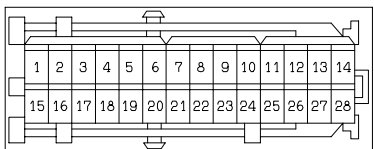

(C-217)



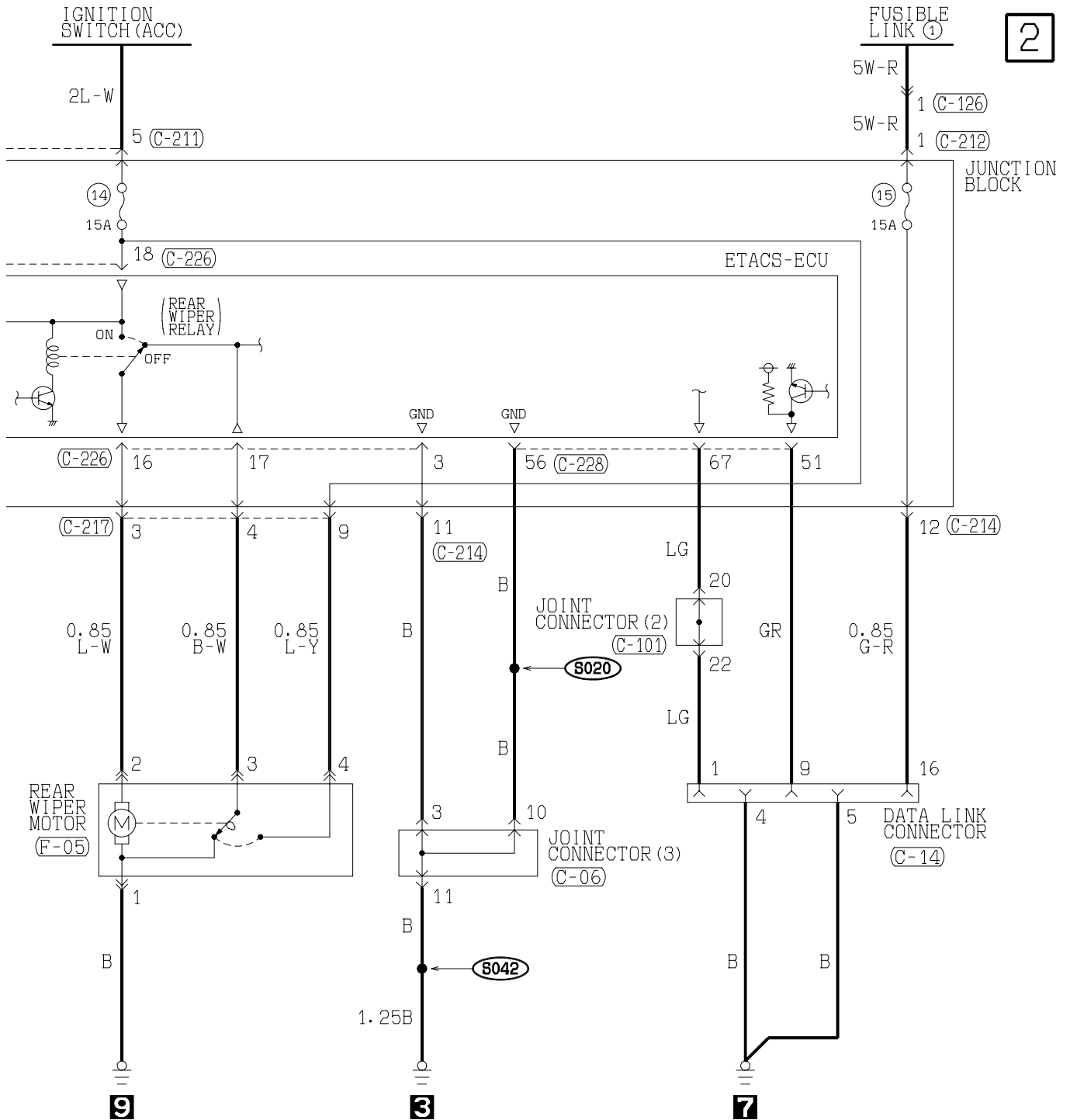

2

(C-126) (MU801380)

1	2	3
---	---	---

(C-129)

1	2	3	4	5	6	7	8	9	10	11	12	13
14	15	16	17	18	19	20	21	22	23	24	25	

(C-206) (MU801514)

1	2	3	4	5
6	7	8	9	10

(C-206-1) UPPER SIDE

1	2	3	4	5	6	7	8	9	10	11
---	---	---	---	---	---	---	---	---	----	----

(C-206-2) UPPER SIDE

1	2	3	4	5	6	7	8	9	10	11
---	---	---	---	---	---	---	---	---	----	----

(C-226) JUNCTION BLOCK SIDE

20	19	18	17	16	15	14	13	12	11	10	9	8	7	6	5	4	3	2	1
----	----	----	----	----	----	----	----	----	----	----	---	---	---	---	---	---	---	---	---

(C-227)

21	22	23	24	25	26	27	28	29
30	31	32	33	34	35	36	37	38
39	40	41		42	43	44		

(C-228)

51	52	53	54	55	56	57	58	59
60	61	62	63	64	65	66	67	68
69	70	71		72	73	74		

(F-05) MU801445

1	2	3	4
---	---	---	---

REAR WIPER AND WASHER (CONTINUED)

3

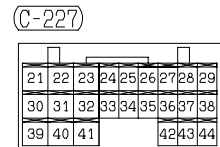
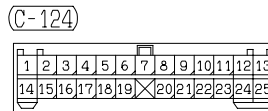
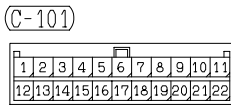
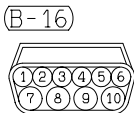
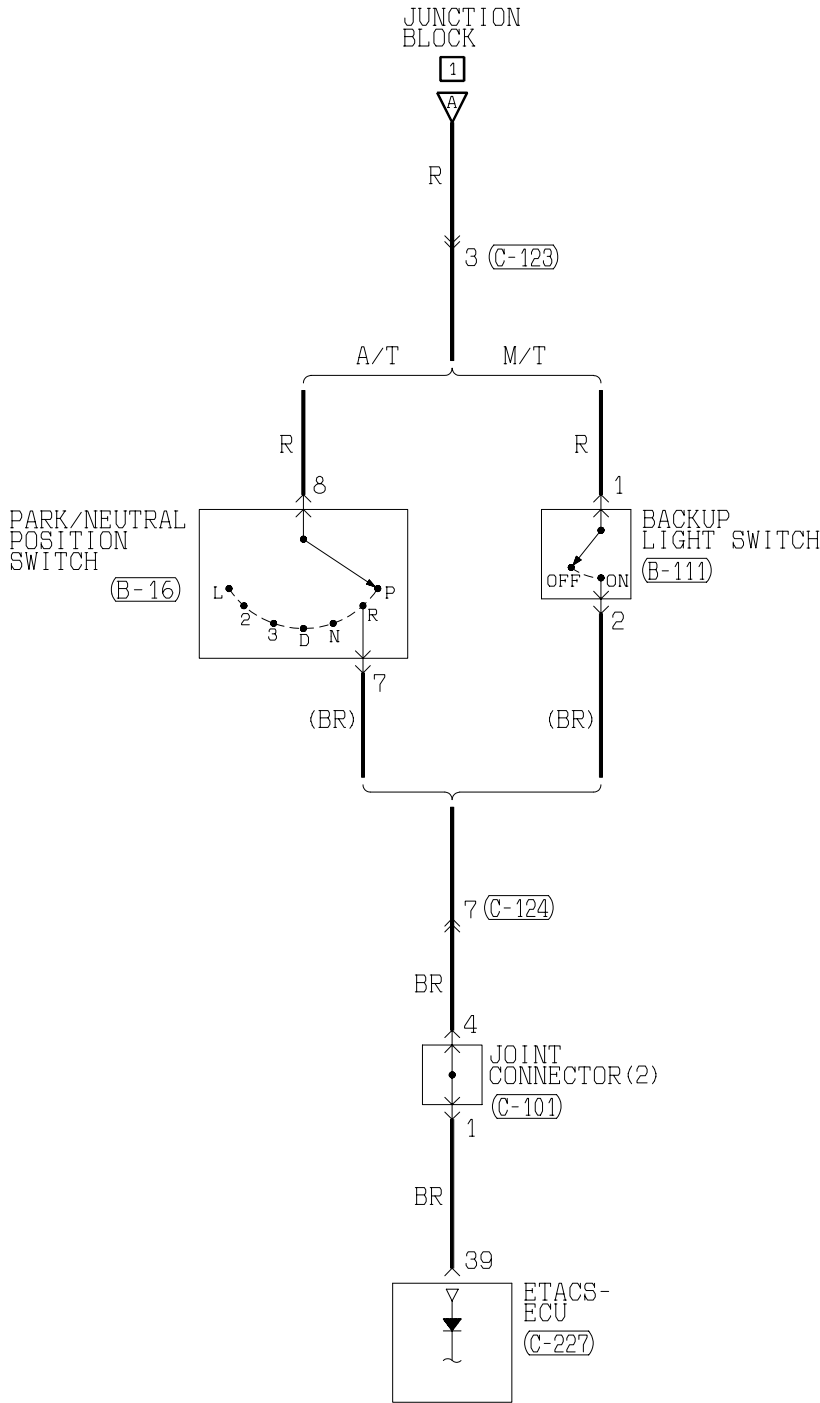

WIRE COLOR CODE
 B : BLACK LG : LIGHT GREEN G : GREEN L : BLUE W : WHITE Y : YELLOW SB : SKY BLUE
 BR : BROWN O : ORANGE GR : GRAY R : RED P : PINK V : VIOLET

REAR WINDOW DEFOGGER

1

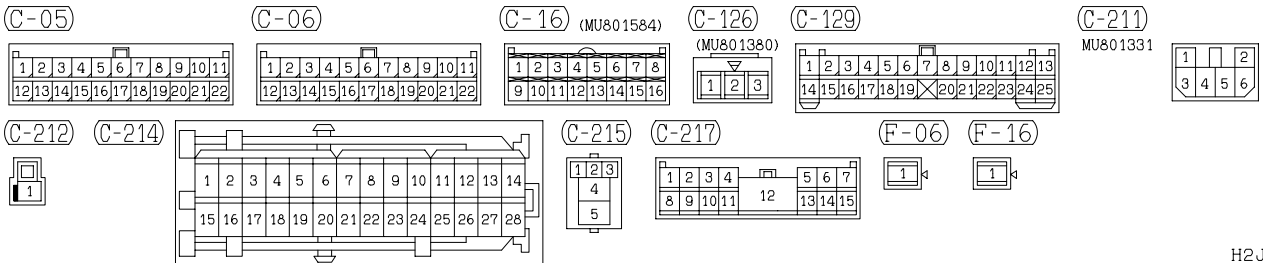
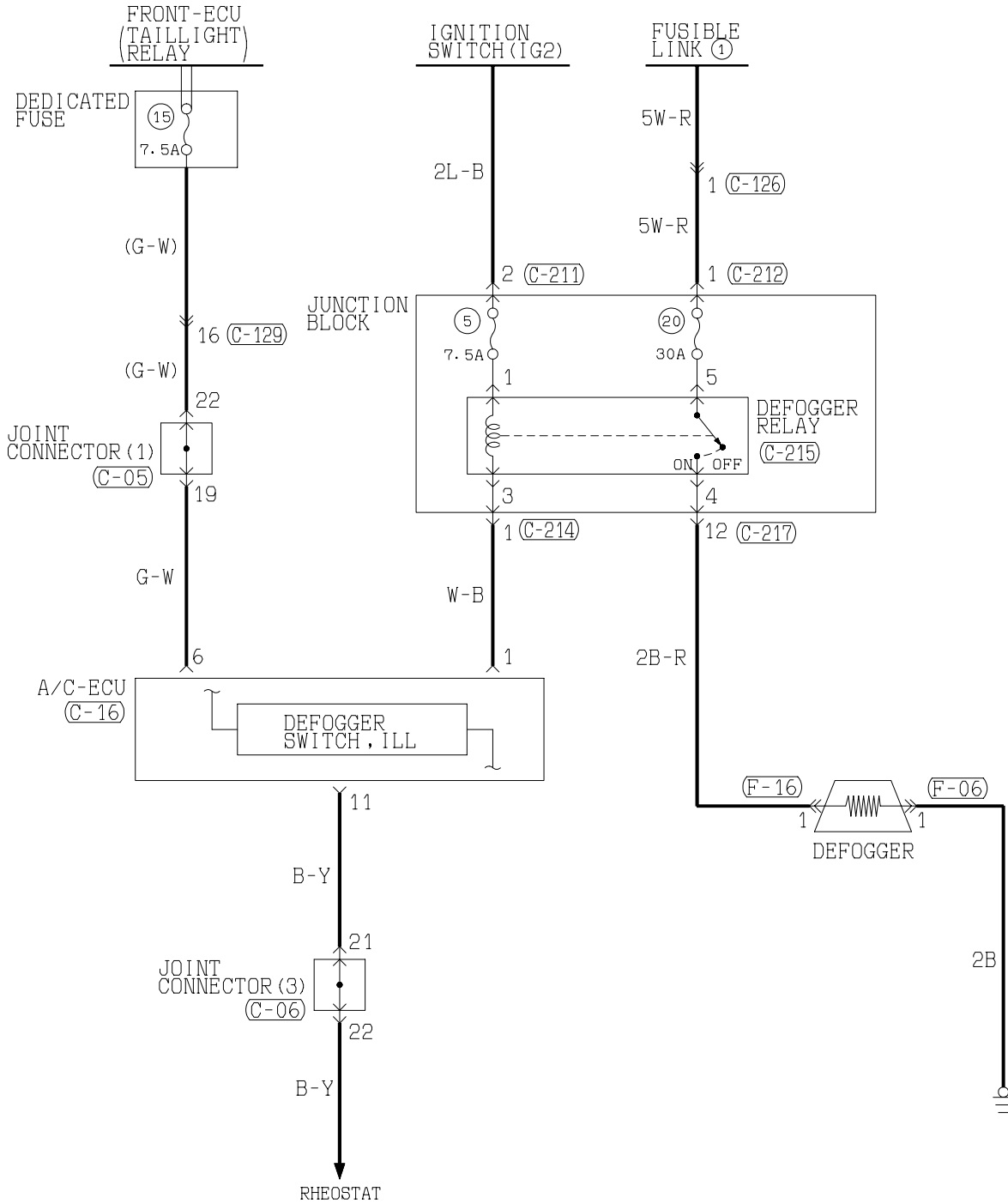

REMOTE CONTROLLED MIRROR

1

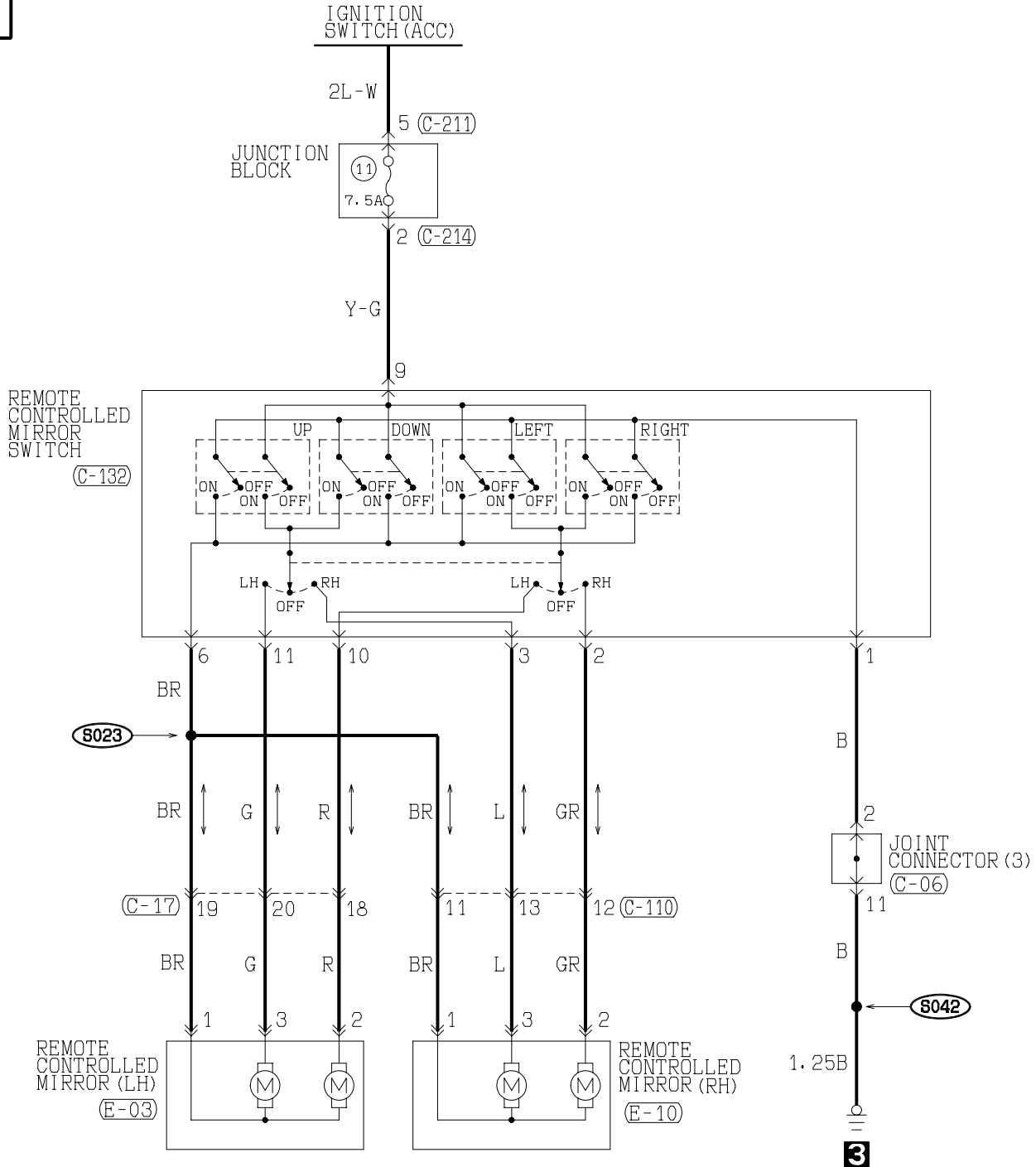

(C-06)

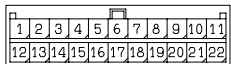

(E-03) (E-10)

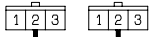

(C-17)



(C-110)

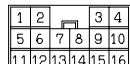

(C-132) MU801847

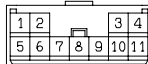

(C-211) MU801331



(C-214)

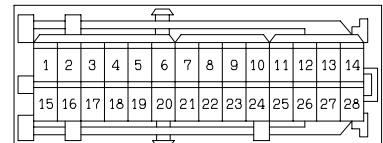

H2J13M03AA

NOTES

AUDIO SYSTEM

M3030015600021

1

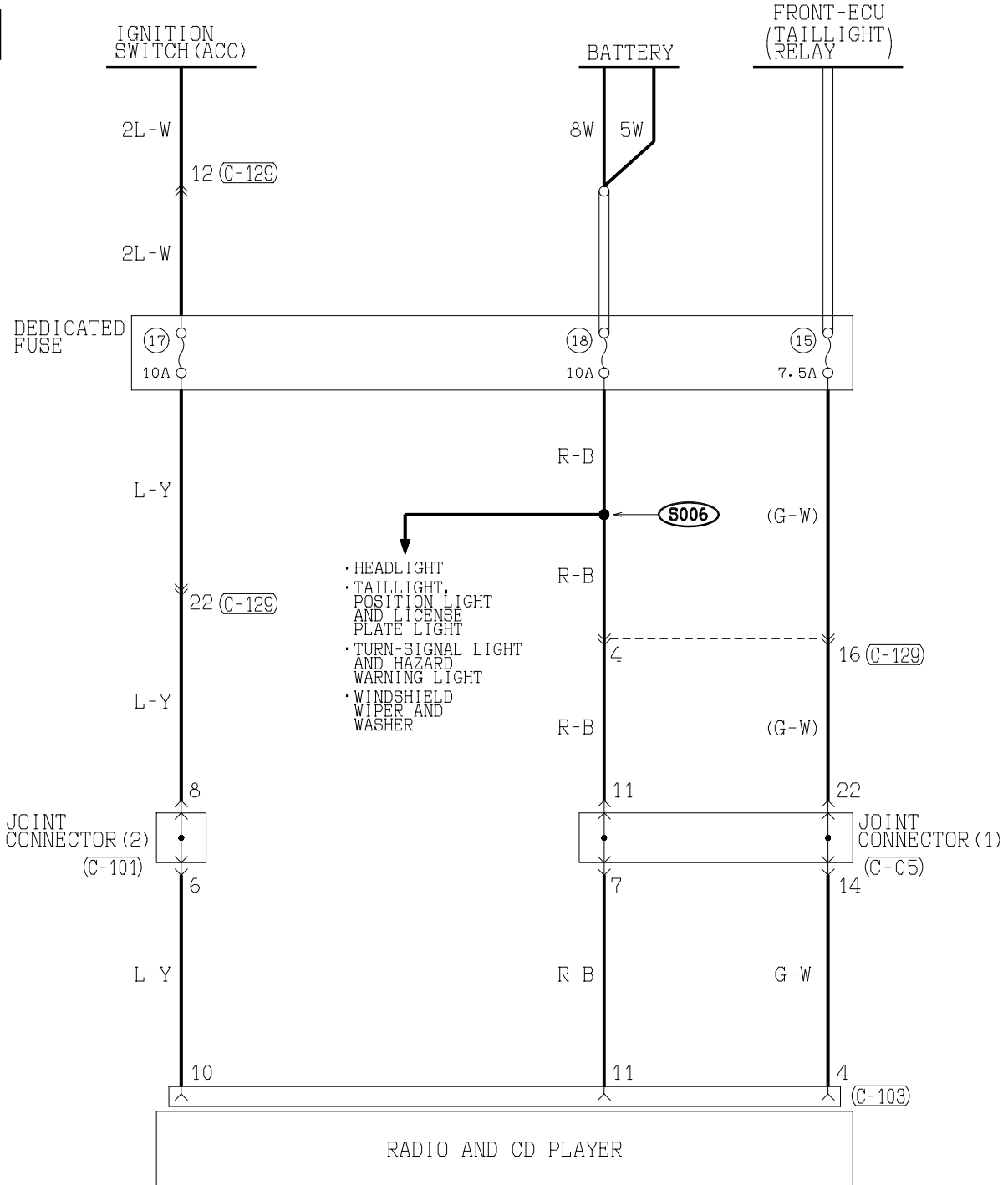

(C-05)

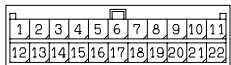

(C-06)

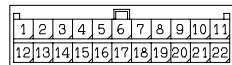

(C-17)

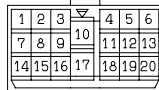

(C-18)

MU801697



(C-21)

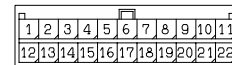

(E-04)

MU801671



(E-15)

MU801671



(F-01)

MU801671



(F-07)

MU801671



H2J14M00AA

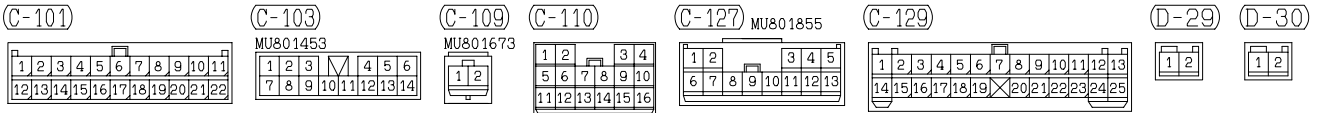
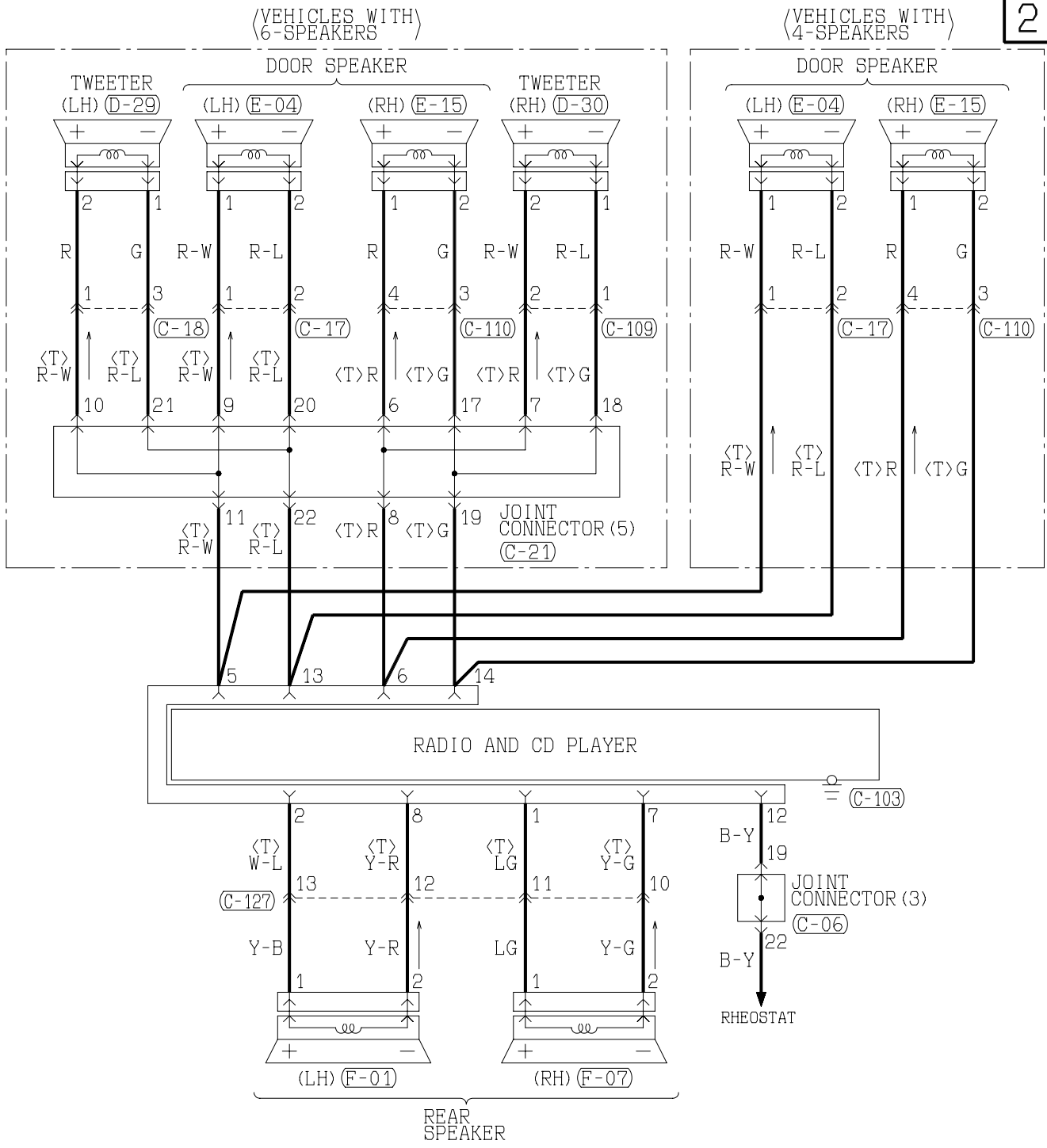

AUDIO SYSTEM (CONTINUED)

3

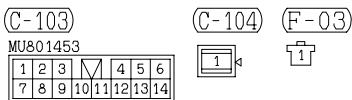
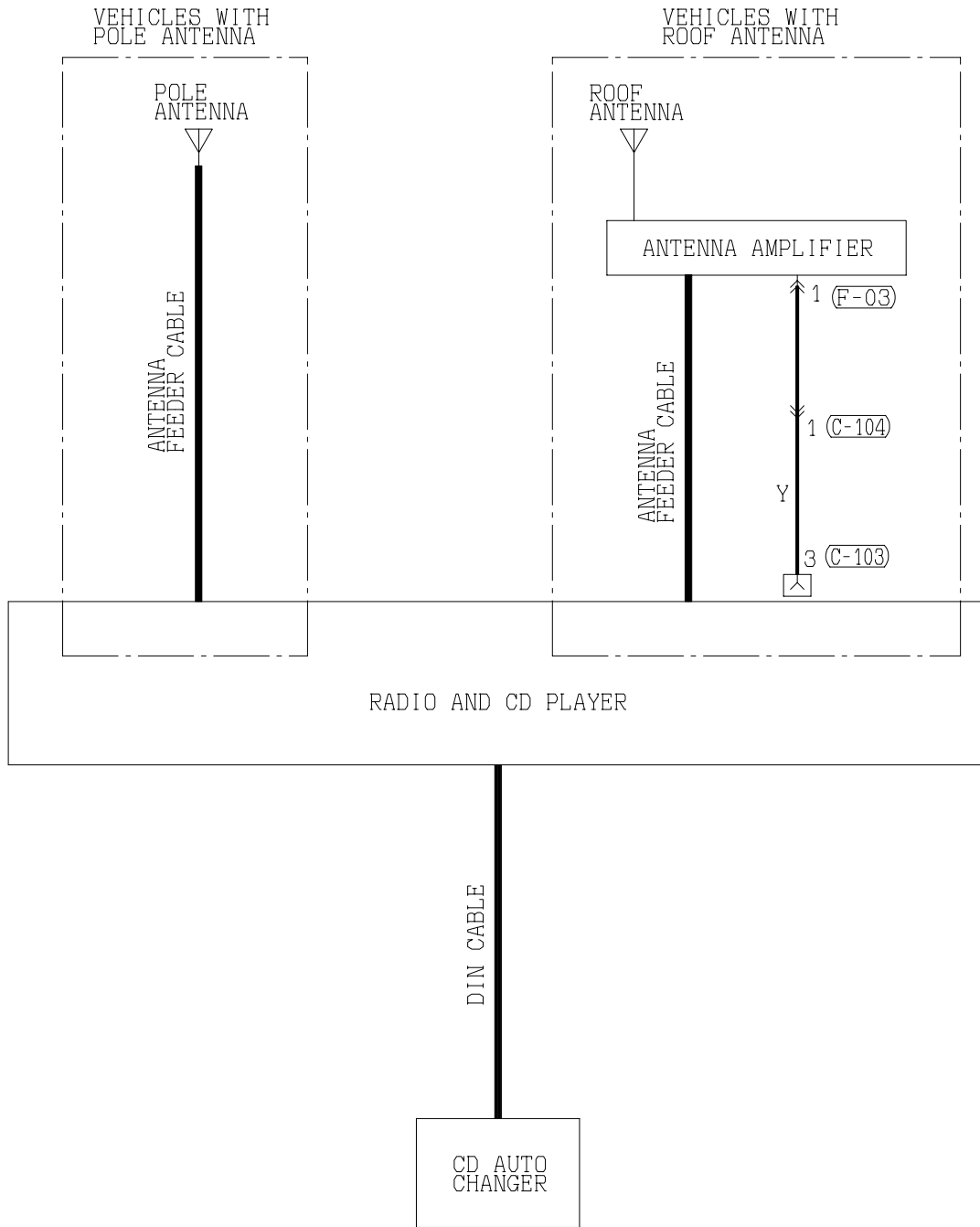

WIRE COLOR CODE
 B : BLACK LG : LIGHT GREEN G : GREEN L : BLUE W : WHITE Y : YELLOW SB : SKY BLUE
 BR : BROWN O : ORANGE GR : GRAY R : RED P : PINK V : VIOLET

H2J14M00BA

NOTES

CLOCK

1

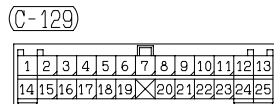
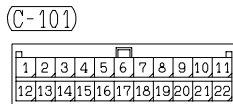
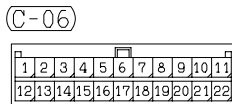
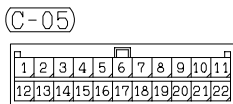
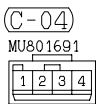
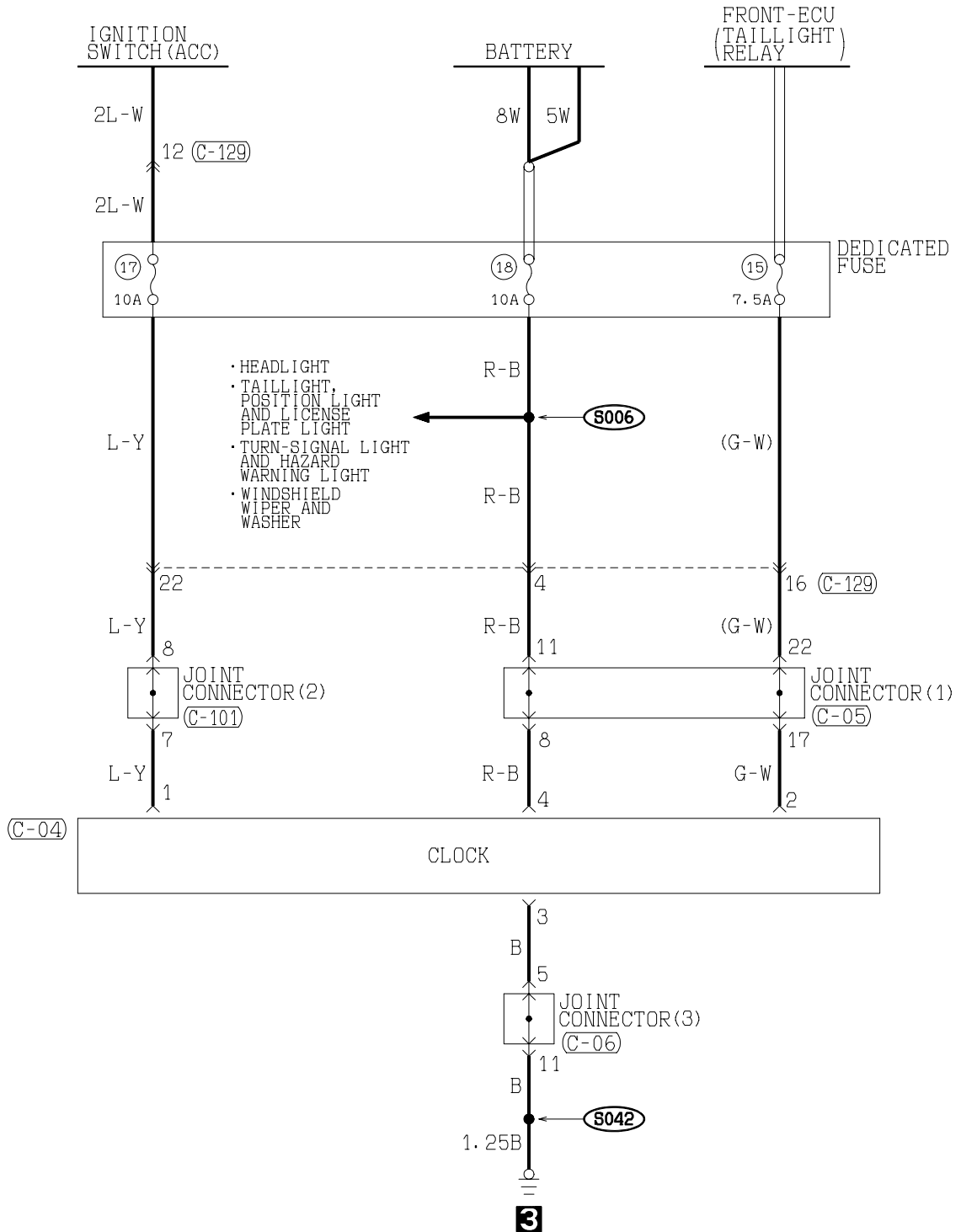

WIRE COLOR CODE

B : BLACK LG : LIGHT GREEN G : GREEN L : BLUE W : WHITE Y : YELLOW SB : SKY BLUE

BR : BROWN O : ORANGE GR : GRAY R : RED P : PINK V : VIOLET

CIGARETTE LIGHTER

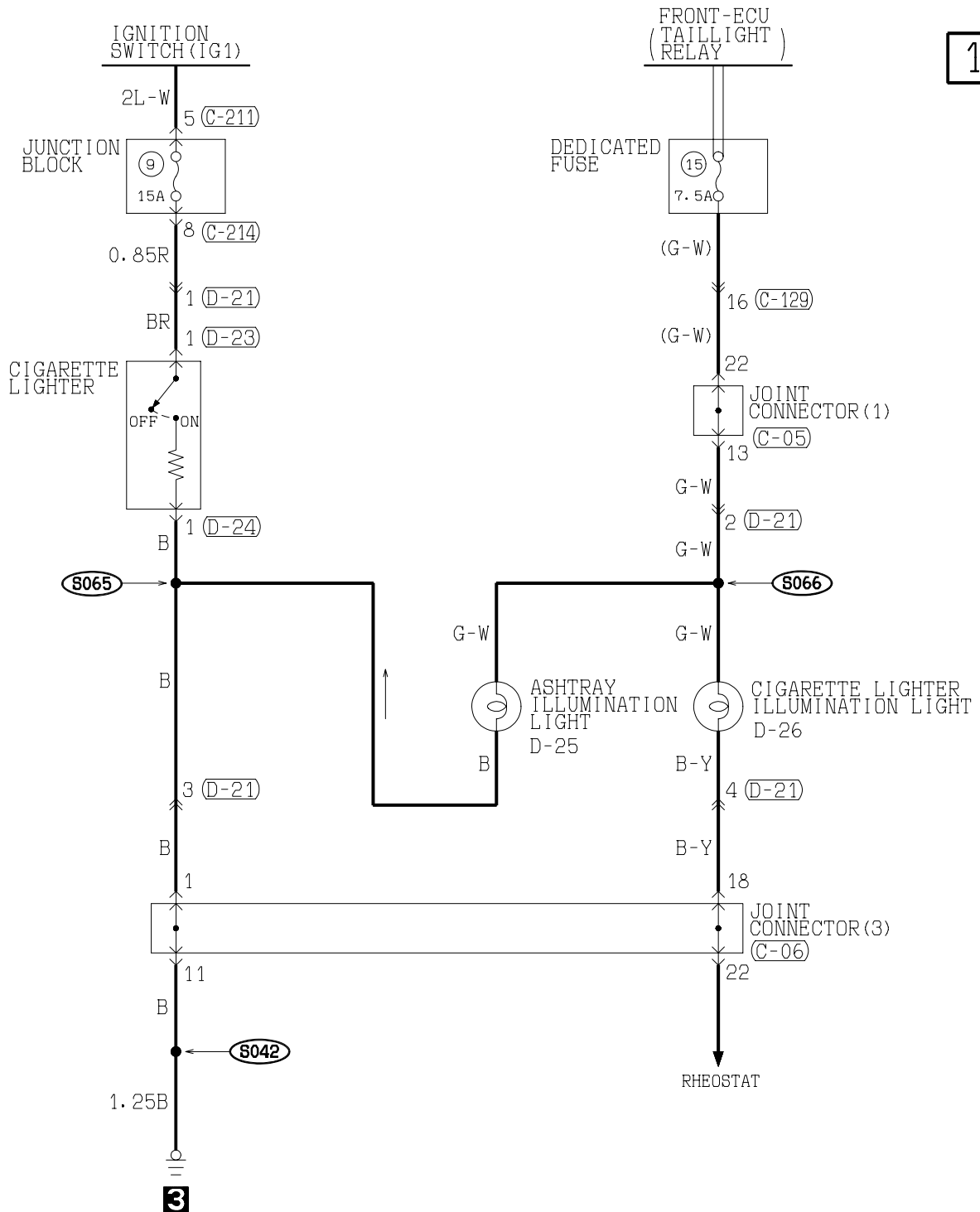

(C-05)

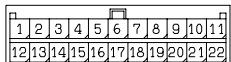

(C-06)

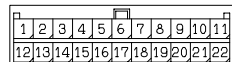

(C-129)

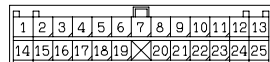

(C-211)



(C-214)

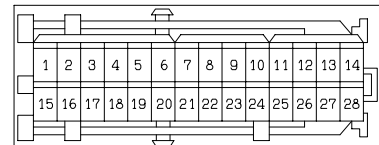

(D-21)

MU801687



(D-23)



(D-24)

(MU801211)



AUTO-CRUISE CONTROL SYSTEM <M/T>

M3030009300010

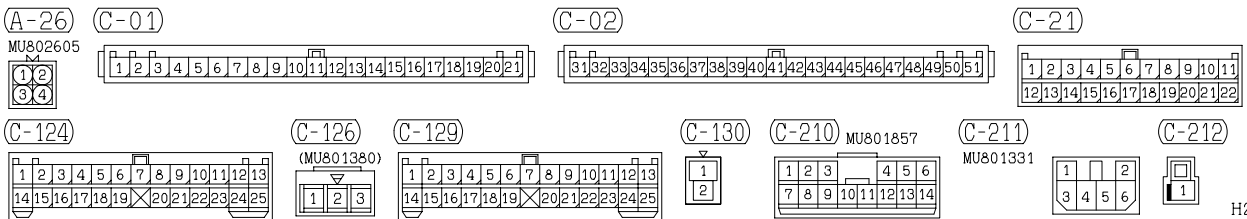
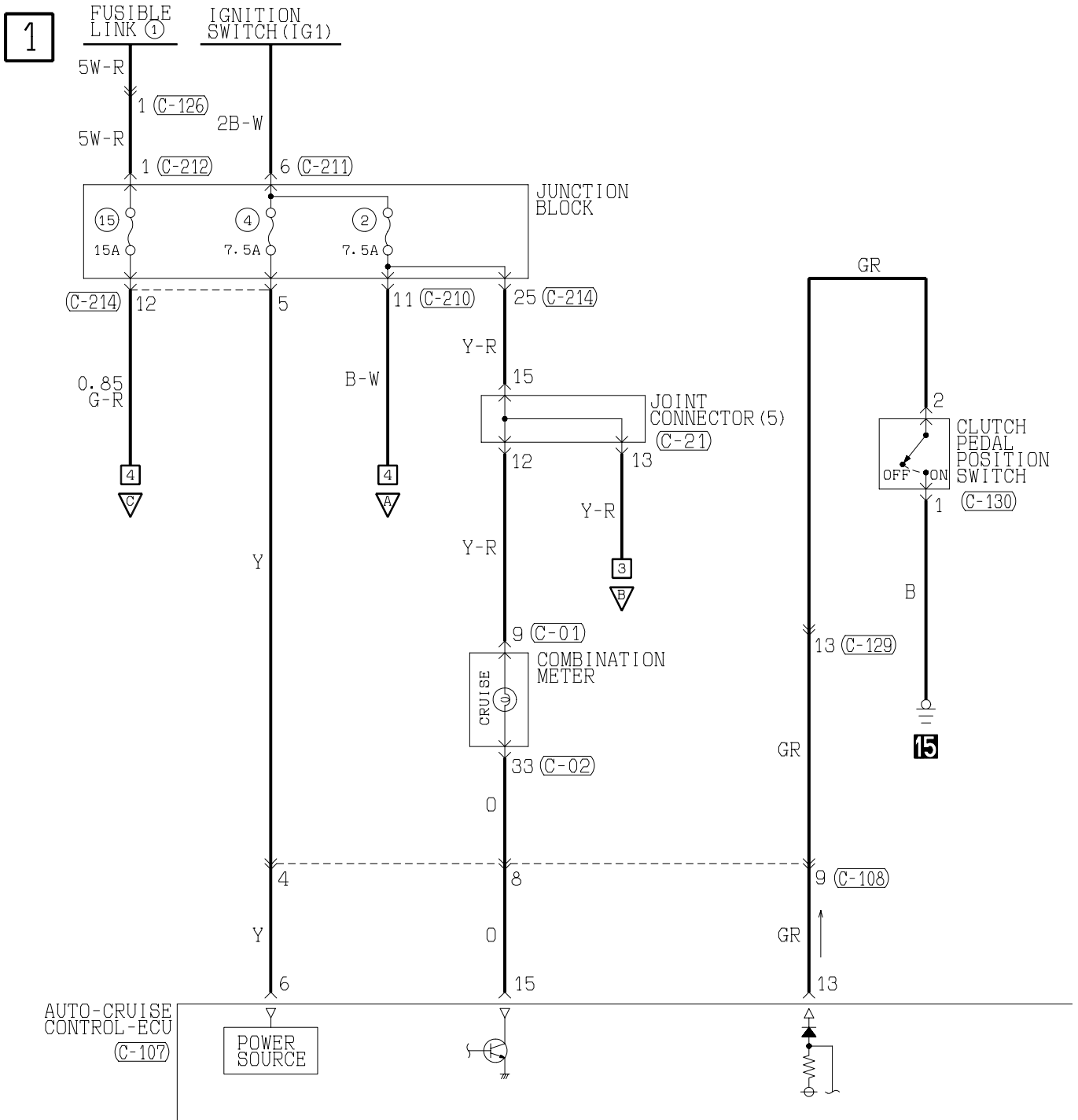

H2J15M00AA

2

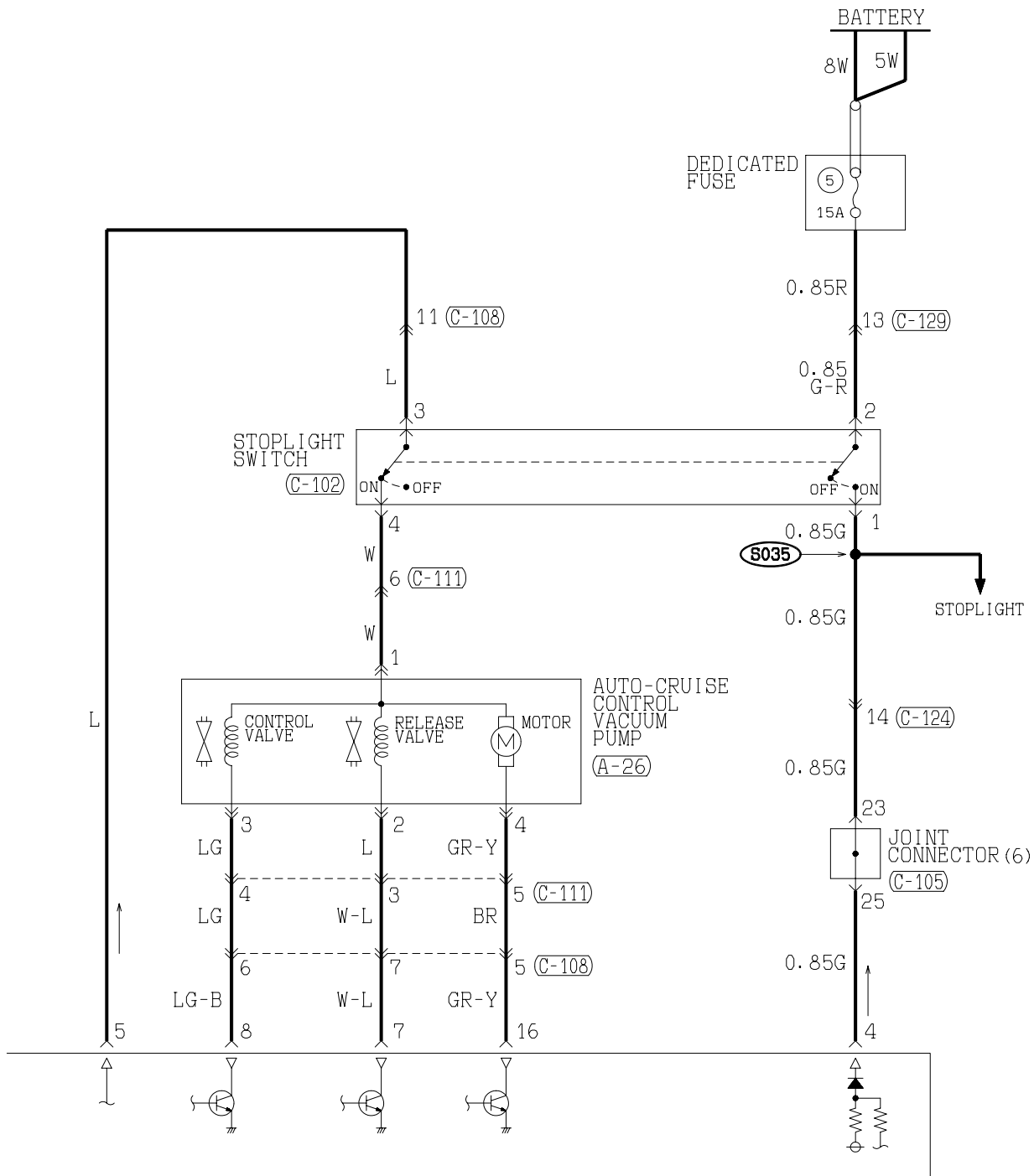

(C-102) (MU801490)



(C-105)



(C-107) (MU801584)



(C-108) MU801847

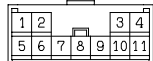

(C-111)

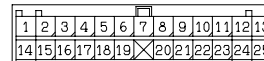

(C-214)

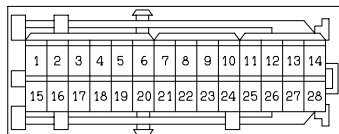

WIRE COLOR CODE
 B : BLACK LG : LIGHT GREEN G : GREEN L : BLUE
 BR : BROWN O : ORANGE GR : GRAY R : RED
 W : WHITE SB : SKY BLUE P : PINK Y : YELLOW
 V : VIOLET

H2J15M00AB

AUTO-CRUISE CONTROL SYSTEM <M/T> (CONTINUED)

3

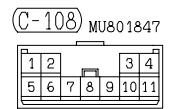
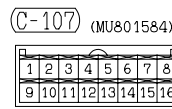
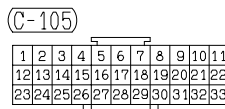
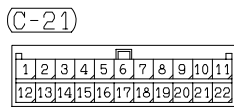
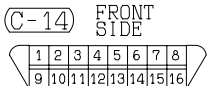
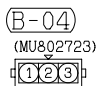
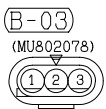
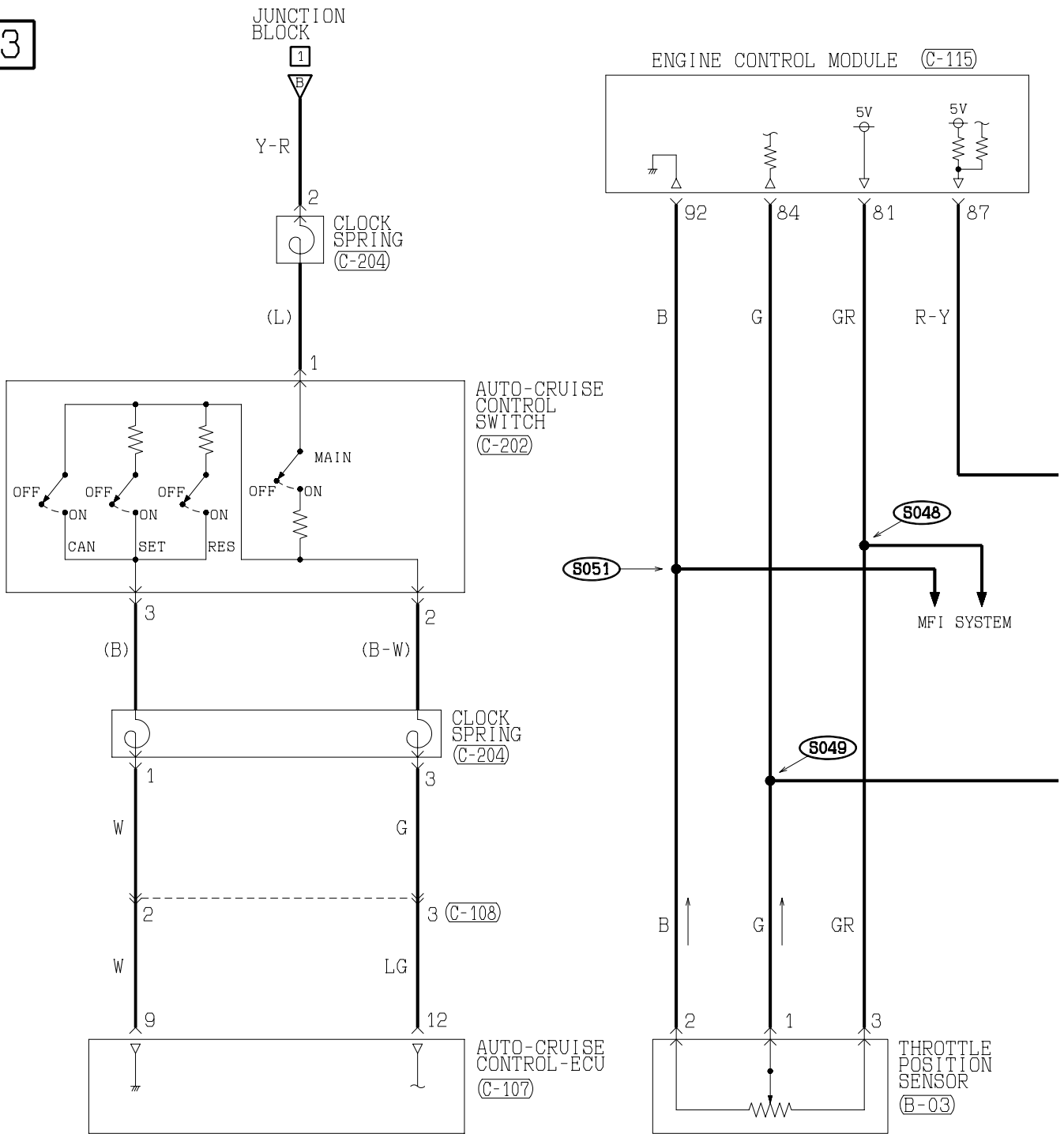

4

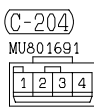
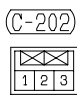
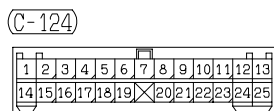
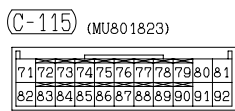
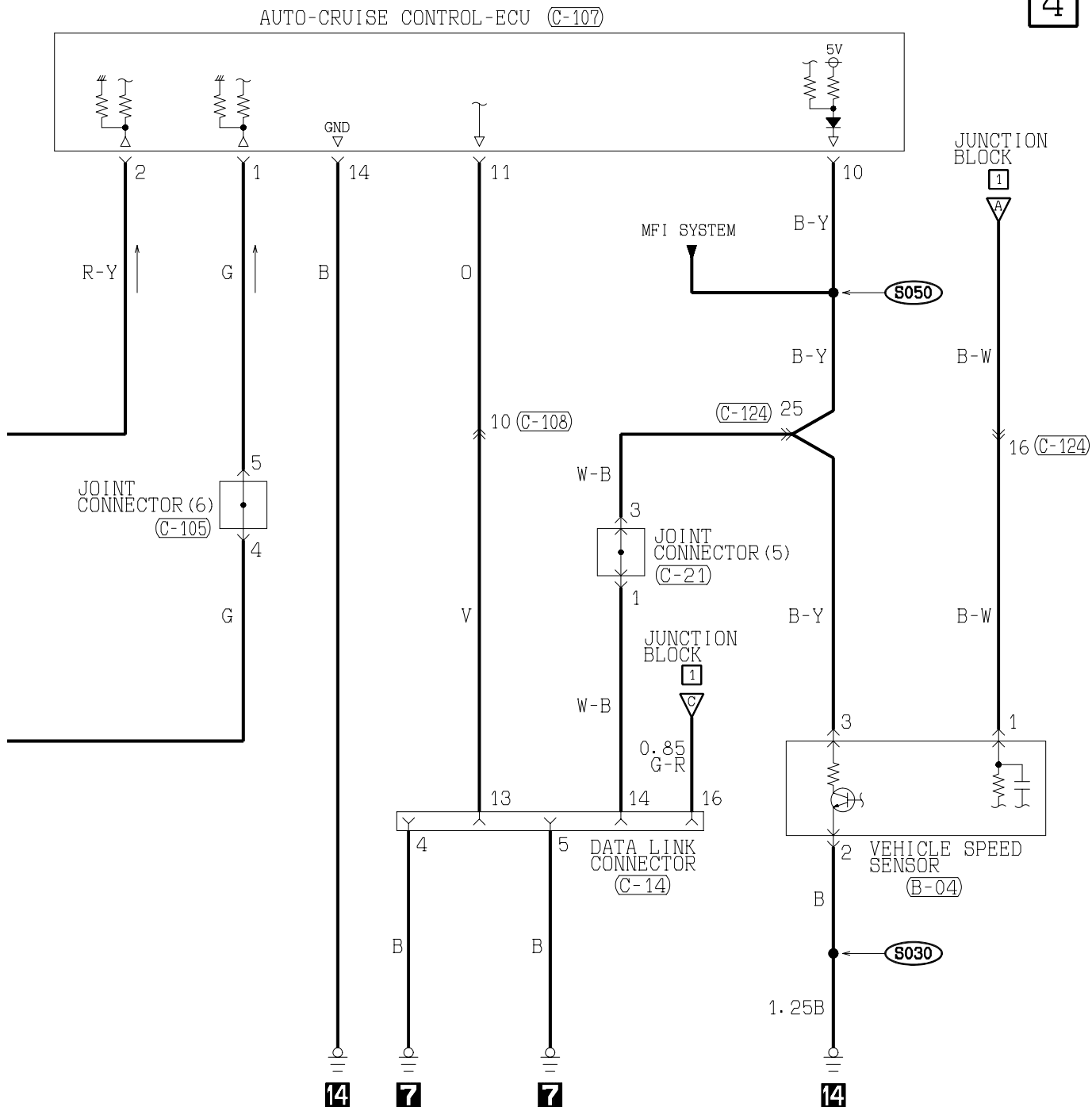

WIRE COLOR CODE
 B : BLACK BR : BROWN G : GREEN GR : GRAY L : BLUE LG : LIGHT GREEN O : ORANGE
 P : PINK R : RED SB : SKY BLUE V : VIOLET W : WHITE Y : YELLOW

H2J15M00BB

AUTO-CRUISE CONTROL SYSTEM <A/T>

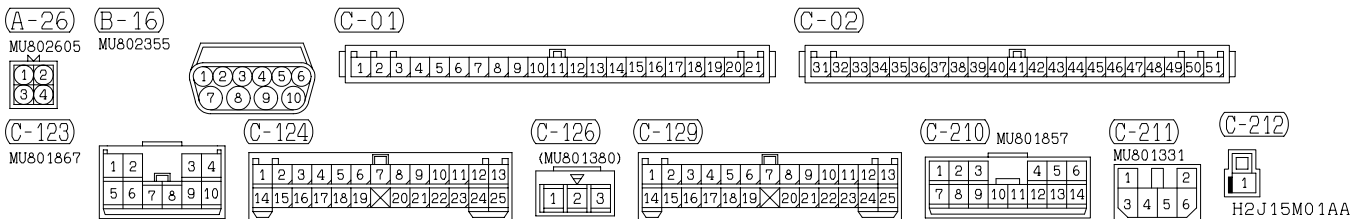
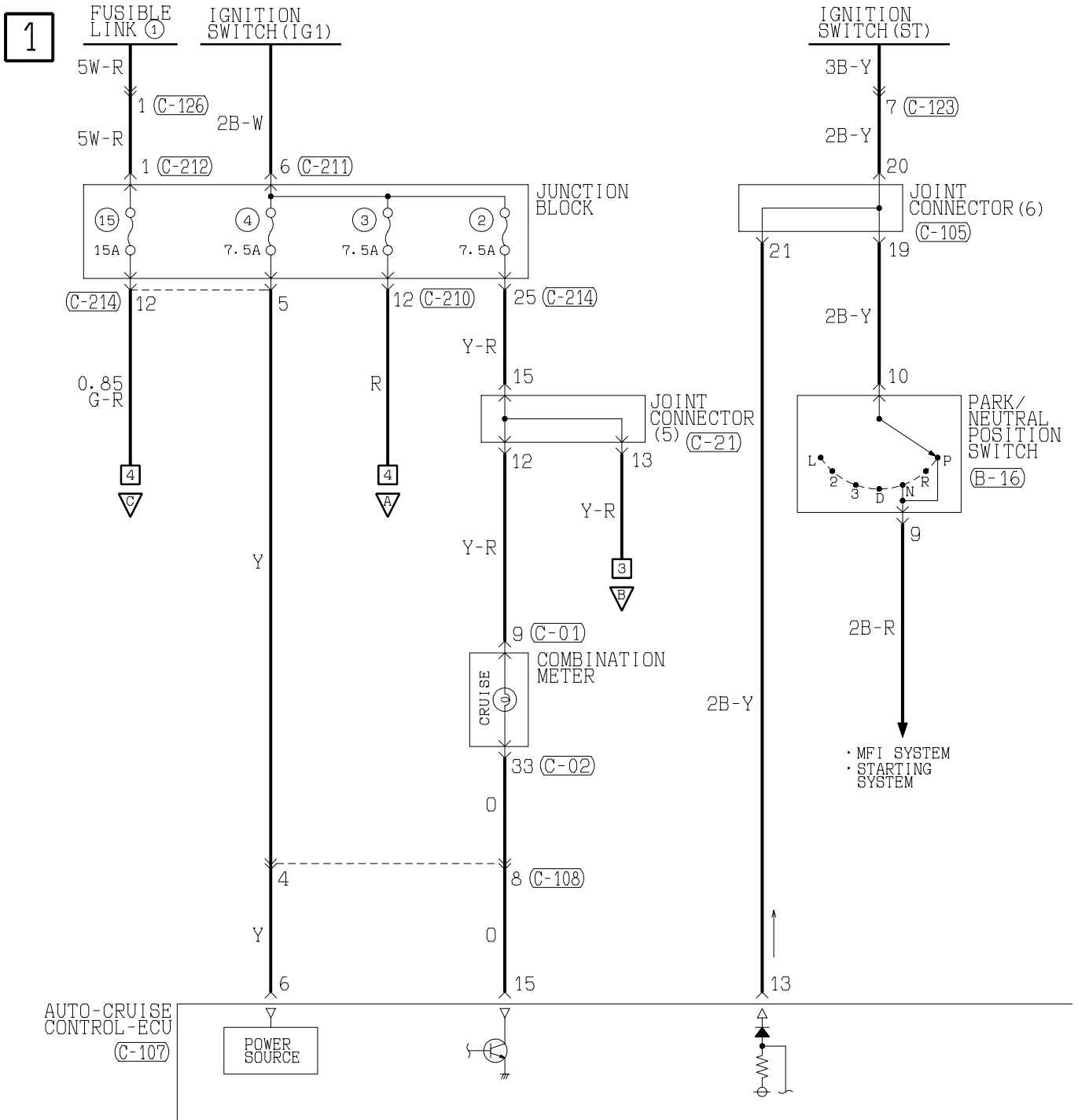

2

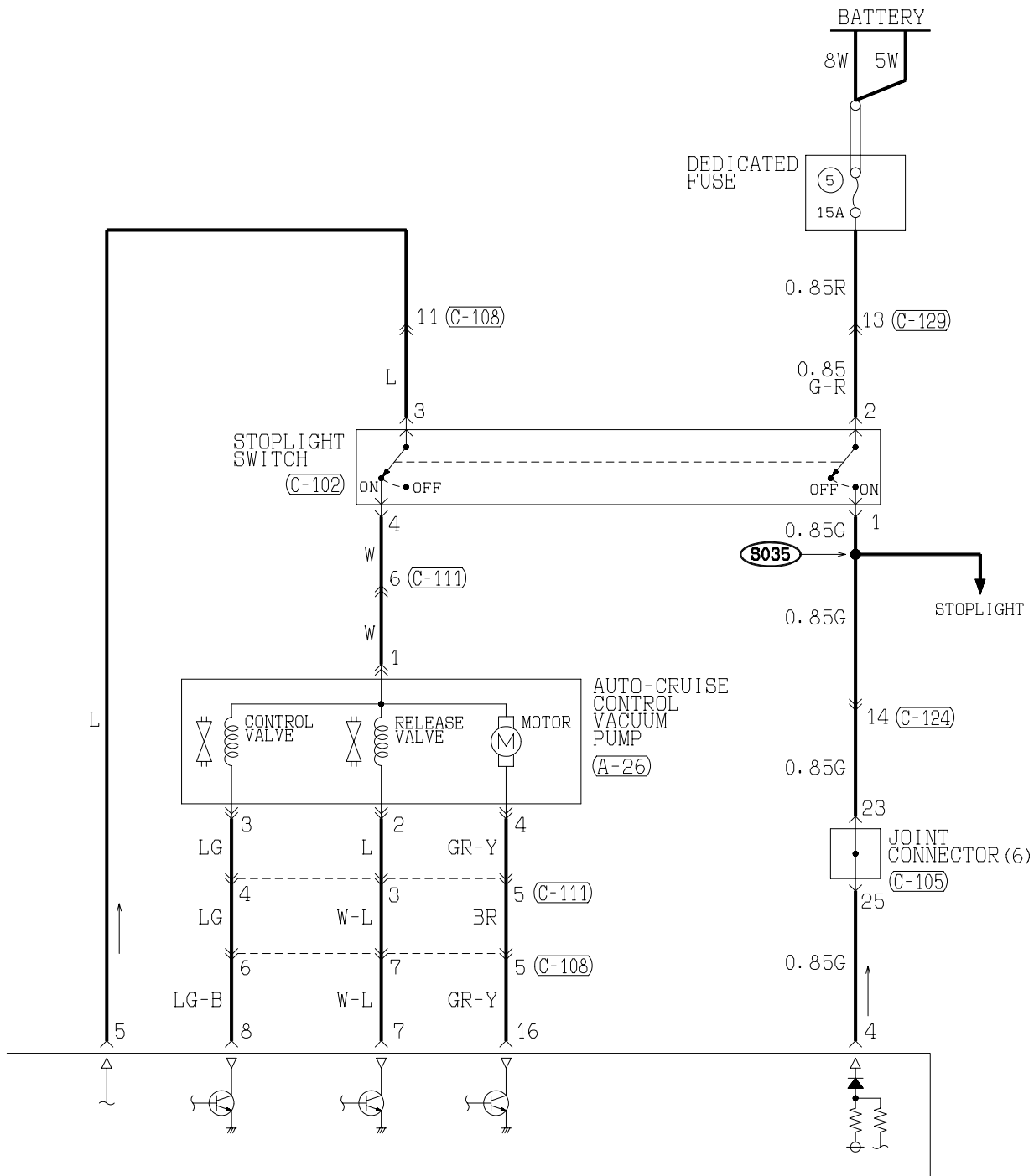

<p>(C-21)</p> <table border="1" style="border-collapse: collapse; text-align: center;"> <tr><td>1</td><td>2</td><td>3</td><td>4</td><td>5</td><td>6</td><td>7</td><td>8</td><td>9</td><td>10</td><td>11</td></tr> <tr><td>12</td><td>13</td><td>14</td><td>15</td><td>16</td><td>17</td><td>18</td><td>19</td><td>20</td><td>21</td><td>22</td></tr> </table>	1	2	3	4	5	6	7	8	9	10	11	12	13	14	15	16	17	18	19	20	21	22	<p>(C-102) (MU801490)</p> <table border="1" style="border-collapse: collapse; text-align: center;"> <tr><td>1</td><td>2</td></tr> <tr><td>3</td><td>4</td></tr> </table>	1	2	3	4	<p>(C-105)</p> <table border="1" style="border-collapse: collapse; text-align: center;"> <tr><td>1</td><td>2</td><td>3</td><td>4</td><td>5</td><td>6</td><td>7</td><td>8</td><td>9</td><td>10</td><td>11</td></tr> <tr><td>12</td><td>13</td><td>14</td><td>15</td><td>16</td><td>17</td><td>18</td><td>19</td><td>20</td><td>21</td><td>22</td></tr> <tr><td>23</td><td>24</td><td>25</td><td>26</td><td>27</td><td>28</td><td>29</td><td>30</td><td>31</td><td>32</td><td>33</td></tr> </table>	1	2	3	4	5	6	7	8	9	10	11	12	13	14	15	16	17	18	19	20	21	22	23	24	25	26	27	28	29	30	31	32	33	<p>(C-107) (MU801584)</p> <table border="1" style="border-collapse: collapse; text-align: center;"> <tr><td>1</td><td>2</td><td>3</td><td>4</td><td>5</td><td>6</td><td>7</td><td>8</td></tr> <tr><td>9</td><td>10</td><td>11</td><td>12</td><td>13</td><td>14</td><td>15</td><td>16</td></tr> </table>	1	2	3	4	5	6	7	8	9	10	11	12	13	14	15	16	<p>(C-108) MU801847</p> <table border="1" style="border-collapse: collapse; text-align: center;"> <tr><td>1</td><td>2</td><td>3</td><td>4</td></tr> <tr><td>5</td><td>6</td><td>7</td><td>8</td></tr> <tr><td>9</td><td>10</td><td>11</td><td>12</td></tr> </table>	1	2	3	4	5	6	7	8	9	10	11	12	<p>(C-111)</p> <table border="1" style="border-collapse: collapse; text-align: center;"> <tr><td>1</td><td>2</td><td>3</td><td>4</td><td>5</td><td>6</td><td>7</td><td>8</td><td>9</td><td>10</td><td>11</td><td>12</td><td>13</td></tr> <tr><td>14</td><td>15</td><td>16</td><td>17</td><td>18</td><td>19</td><td>20</td><td>21</td><td>22</td><td>23</td><td>24</td><td>25</td><td></td></tr> </table>	1	2	3	4	5	6	7	8	9	10	11	12	13	14	15	16	17	18	19	20	21	22	23	24	25	
1	2	3	4	5	6	7	8	9	10	11																																																																																																												
12	13	14	15	16	17	18	19	20	21	22																																																																																																												
1	2																																																																																																																					
3	4																																																																																																																					
1	2	3	4	5	6	7	8	9	10	11																																																																																																												
12	13	14	15	16	17	18	19	20	21	22																																																																																																												
23	24	25	26	27	28	29	30	31	32	33																																																																																																												
1	2	3	4	5	6	7	8																																																																																																															
9	10	11	12	13	14	15	16																																																																																																															
1	2	3	4																																																																																																																			
5	6	7	8																																																																																																																			
9	10	11	12																																																																																																																			
1	2	3	4	5	6	7	8	9	10	11	12	13																																																																																																										
14	15	16	17	18	19	20	21	22	23	24	25																																																																																																											
<p>(C-214)</p> <table border="1" style="border-collapse: collapse; text-align: center;"> <tr><td>1</td><td>2</td><td>3</td><td>4</td><td>5</td><td>6</td><td>7</td><td>8</td><td>9</td><td>10</td><td>11</td><td>12</td><td>13</td><td>14</td></tr> <tr><td>15</td><td>16</td><td>17</td><td>18</td><td>19</td><td>20</td><td>21</td><td>22</td><td>23</td><td>24</td><td>25</td><td>26</td><td>27</td><td>28</td></tr> </table>					1	2	3	4	5	6	7	8	9	10	11	12	13	14	15	16	17	18	19	20	21	22	23	24	25	26	27	28	<p>WIRE COLOR CODE</p> <p>B : BLACK LG : LIGHT GREEN G : GREEN L : BLUE</p> <p>BR : BROWN O : ORANGE GR : GRAY R : RED</p> <p>W : WHITE SB : SKY BLUE P : PINK Y : YELLOW</p> <p>V : VIOLET</p>																																																																																					
1	2	3	4	5	6	7	8	9	10	11	12	13	14																																																																																																									
15	16	17	18	19	20	21	22	23	24	25	26	27	28																																																																																																									

H2J15M01AB

TSB Revision

AUTO-CRUISE CONTROL SYSTEM <A/T> (CONTINUED)

3

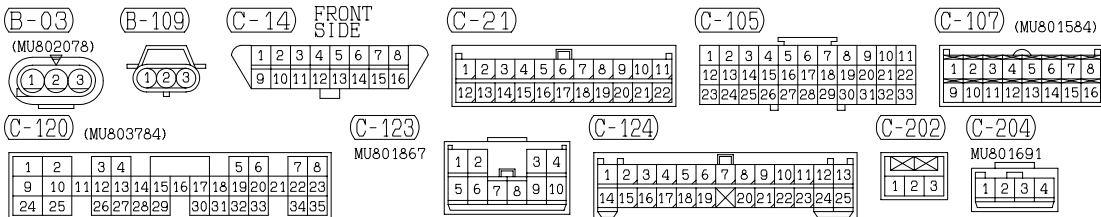
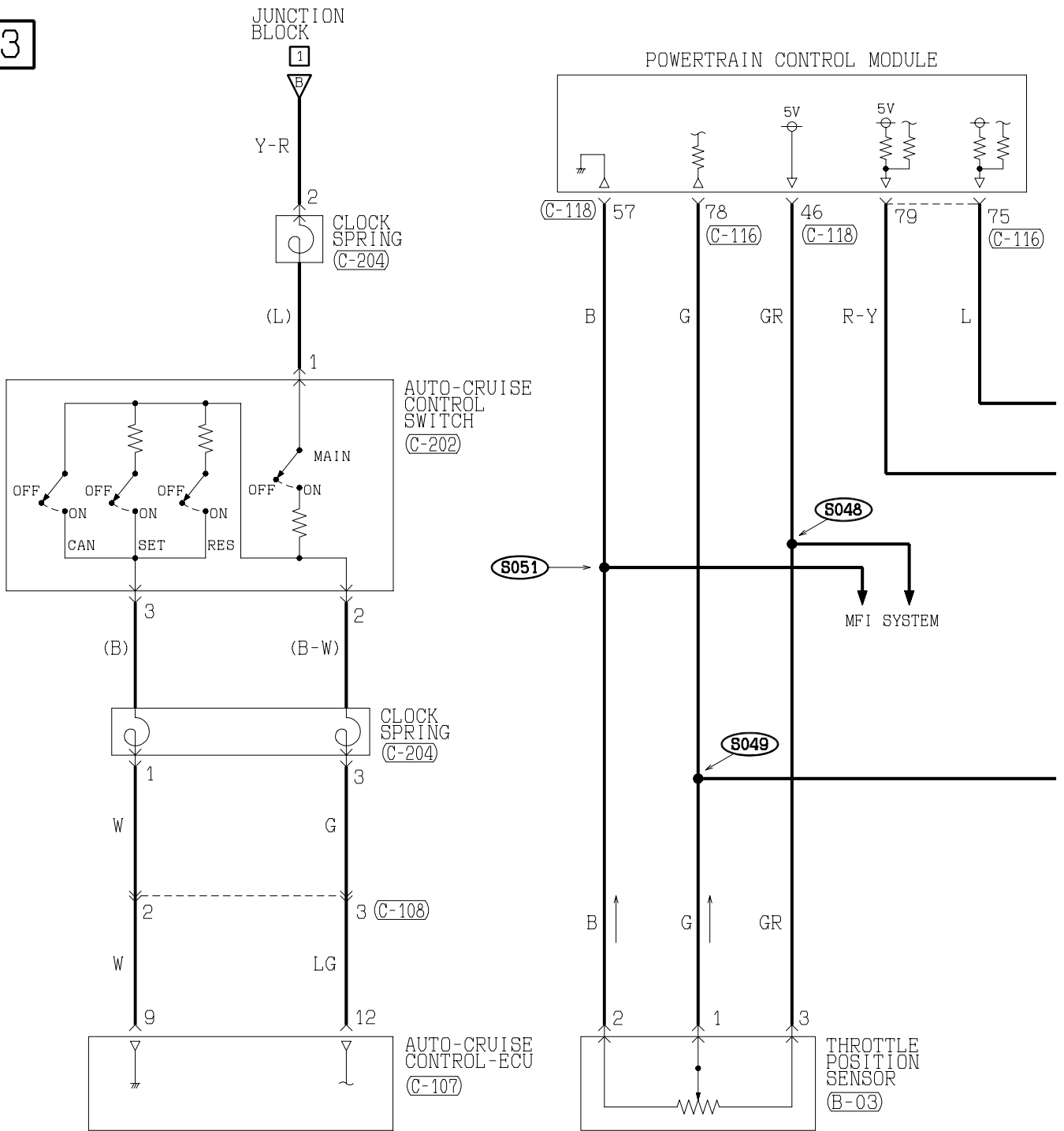

H2J15M01BA

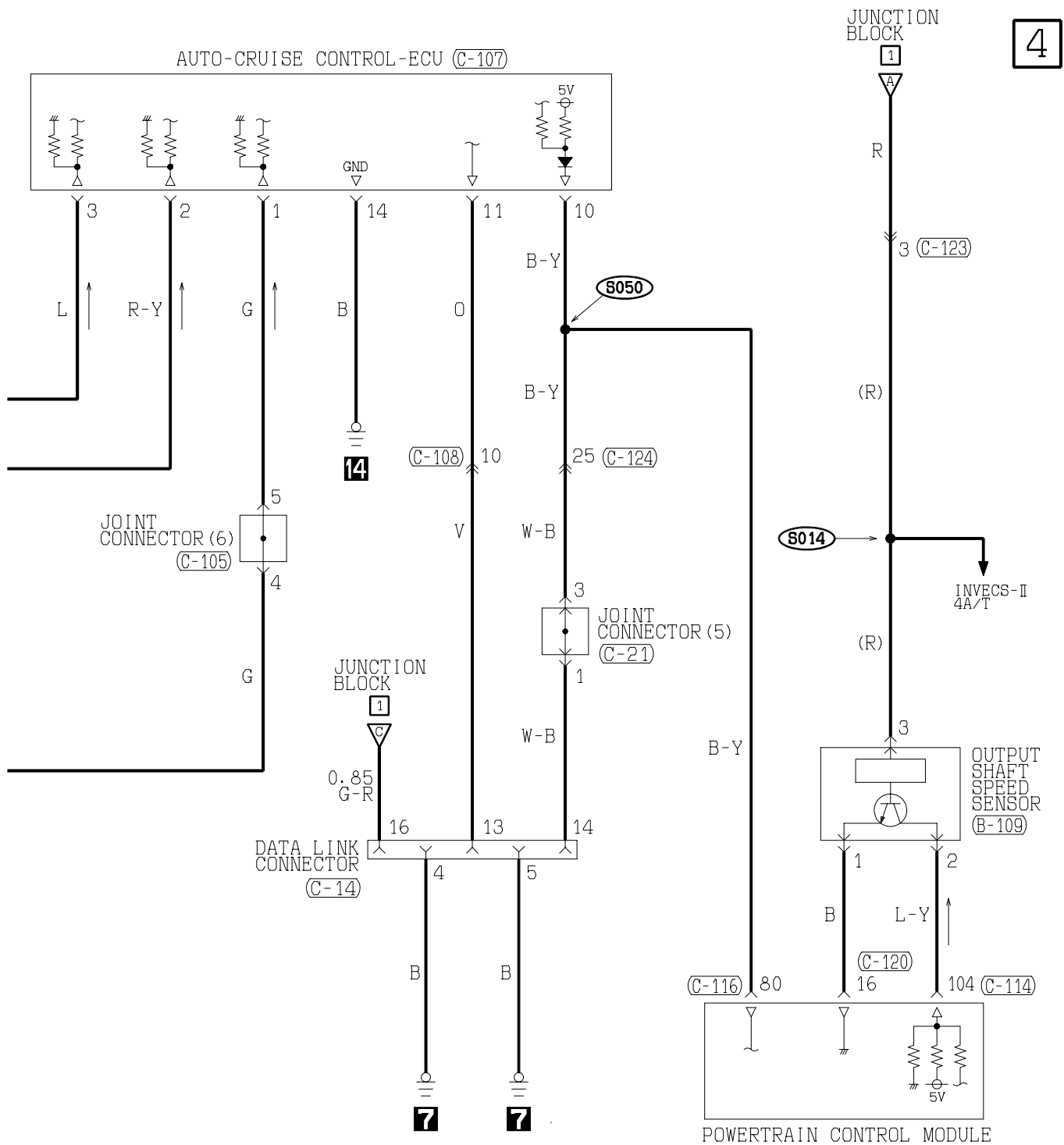

4

(C-108) MU801847

1	2	3	4
5	6	7	8
9	10	11	

(C-114) (MU803783)

101	102	103	104	105	106	107
108	109	110	111	112	113	114
115	116	117	118	119	120	
121	122	123	124	125	126	127
128	129	130				

(C-116) (MU803782)

71	72	73	74	75	76	77
78	79	80	81	82	83	84
85	86	87	88	89		
90	91	92	93	94	95	96
97	98					

(C-118) (MU803781)

41	42	43	44	45	46
47	48	49	50	51	52
53	54	55	56	57	
58	59	60	61	62	63
64	65	66			

WIRE COLOR CODE
 B : BLACK BR : BROWN G : GREEN GR : GRAY L : BLUE LG : LIGHT GREEN O : ORANGE
 P : PINK R : RED SB : SKY BLUE V : VIOLET W : WHITE Y : YELLOW

ANTI-LOCK BRAKING SYSTEM (ABS)

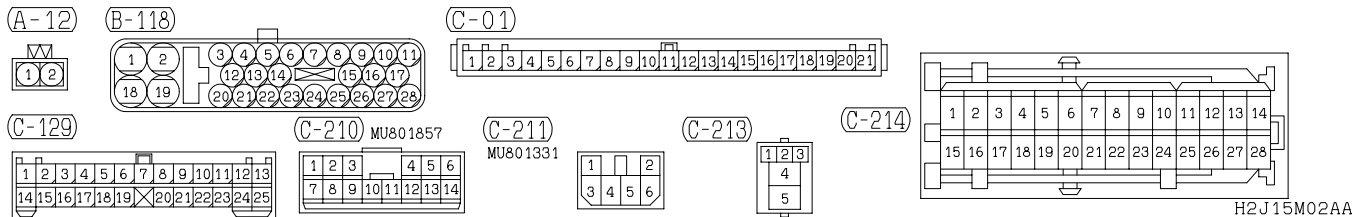
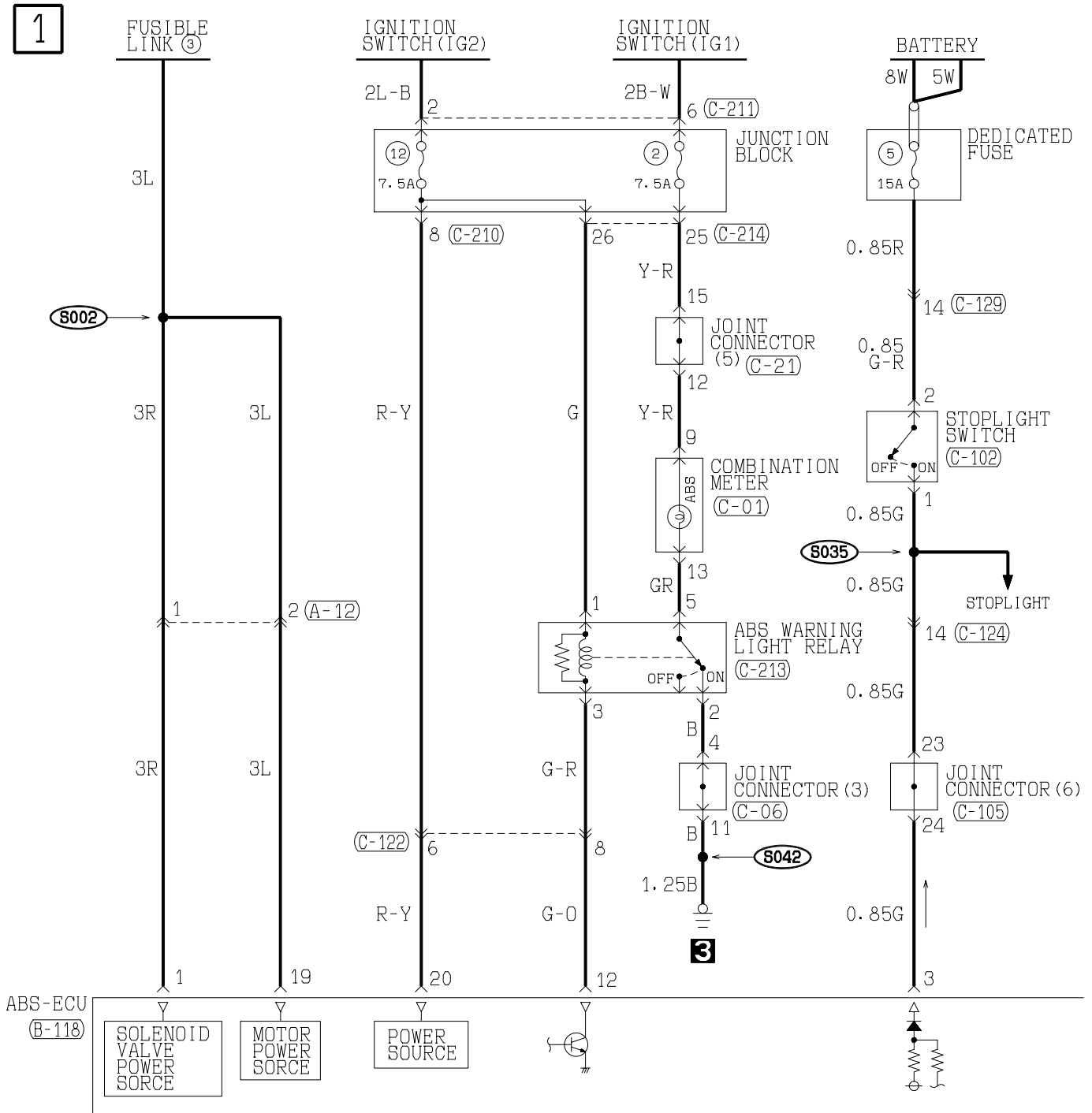

H2J15M02AA

2

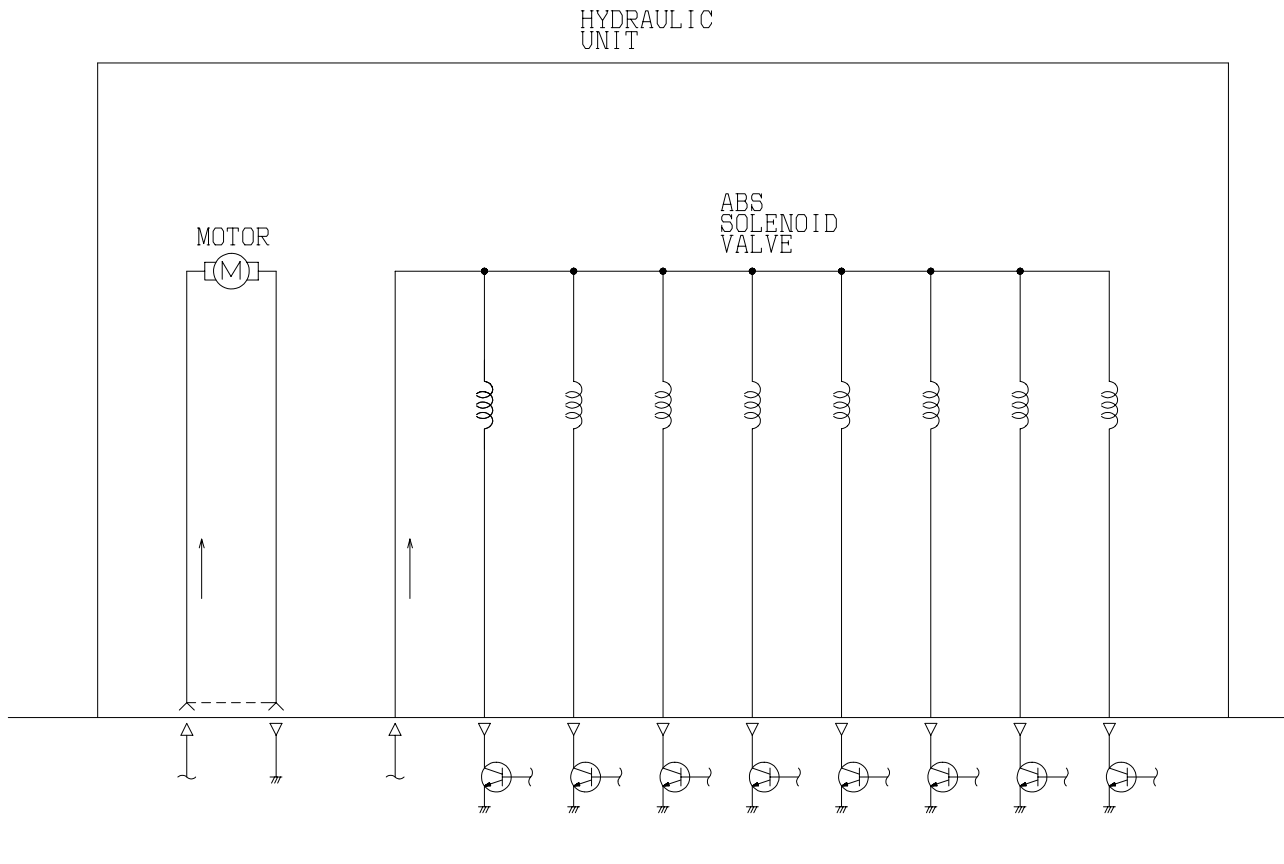

(C-06)

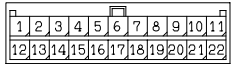

(C-21)

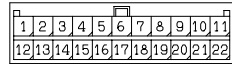

(C-102)



(C-105)

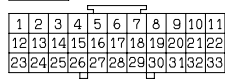

(C-122)

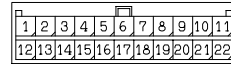

(C-124)

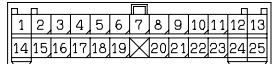

WIRE COLOR CODE
 B : BLACK LG : LIGHT GREEN G : GREEN L : BLUE W : WHITE Y : YELLOW SB : SKY BLUE
 BR : BROWN O : ORANGE GR : GRAY R : RED P : PINK V : VIOLET

H2J15M02AB

TSB Revision

ANTI-LOCK BRAKING SYSTEM (ABS) (CONTINUED)

3

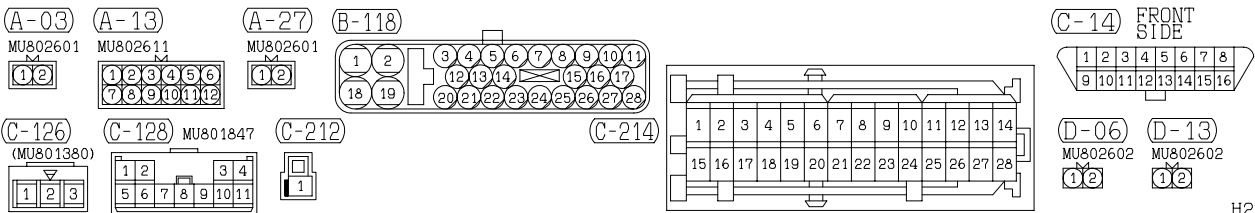
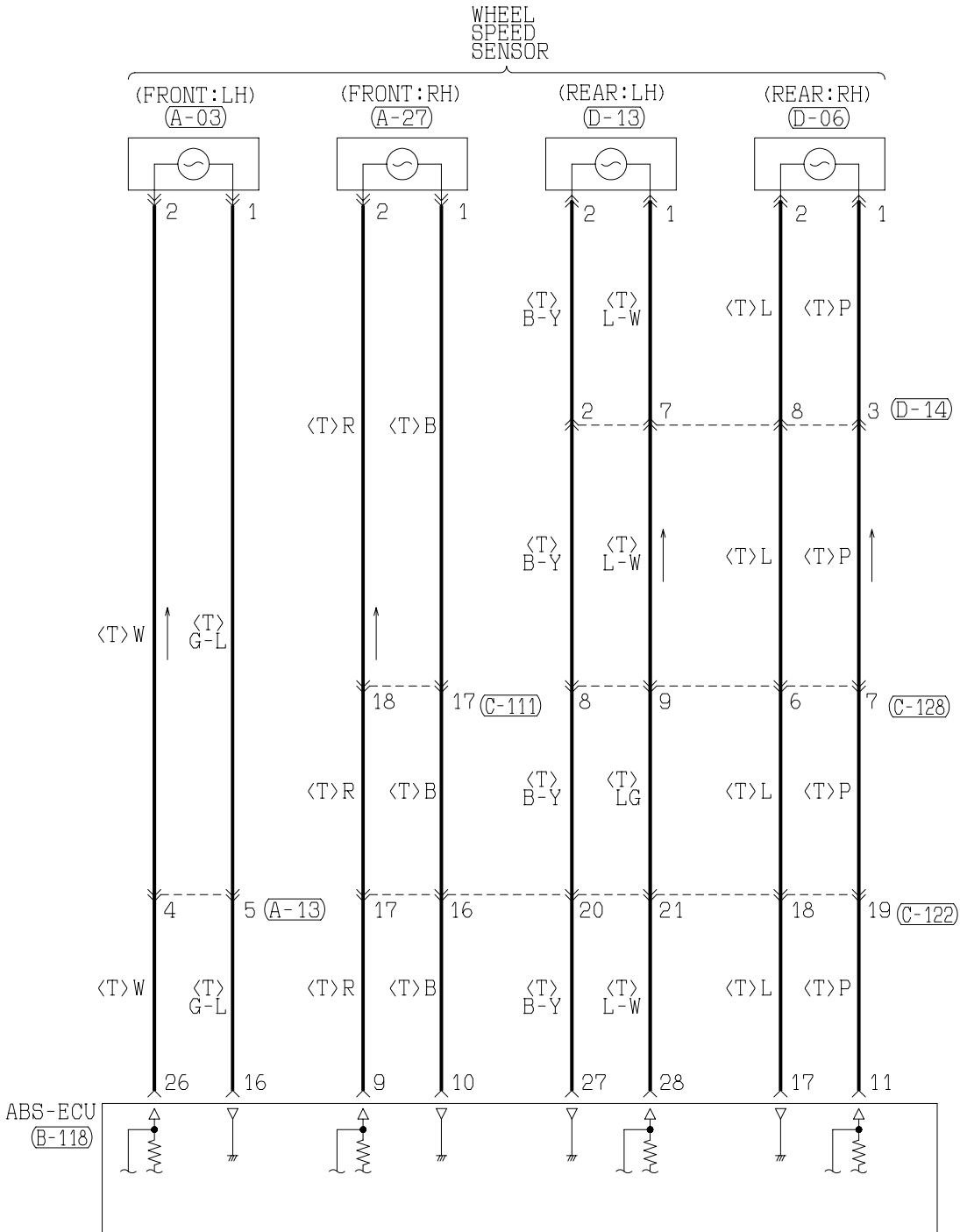

4

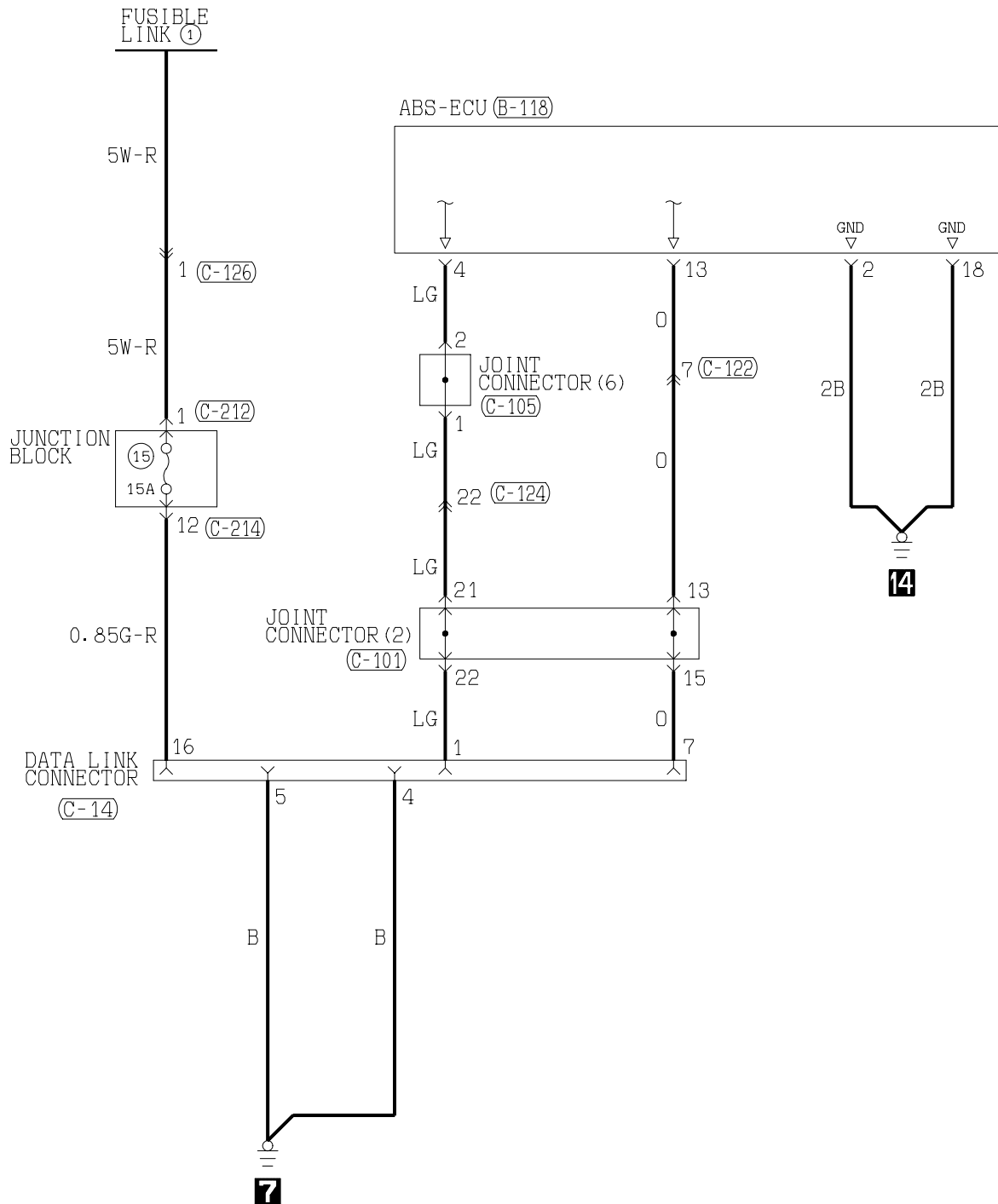

(C-101)

1	2	3	4	5	6	7	8	9	10	11
12	13	14	15	16	17	18	19	20	21	22

(C-105)

1	2	3	4	5	6	7	8	9	10	11
12	13	14	15	16	17	18	19	20	21	22
23	24	25	26	27	28	29	30	31	32	33

(C-111)

1	2	3	4	5	6	7	8	9	10	11	12	13
14	15	16	17	18	19	20	21	22	23	24	25	

(C-122)

1	2	3	4	5	6	7	8	9	10	11
12	13	14	15	16	17	18	19	20	21	22

(C-124)

1	2	3	4	5	6	7	8	9	10	11	12	13
14	15	16	17	18	19	20	21	22	23	24	25	

(D-14)

1	2	3
4	5	6
7	8	

WIRE COLOR CODE

B : BLACK LG : LIGHT GREEN G : GREEN L : BLUE W : WHITE Y : YELLOW SB : SKY BLUE
 BR : BROWN O : ORANGE GR : GRAY R : RED RW : RED/WHITE V : VIOLET

**SUPPLEMENTAL RESTRAINT SYSTEM (SRS)
<VEHICLES WITHOUT SIDE AIR BAG>**

M3030009700018

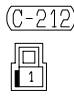
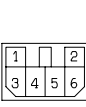
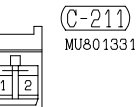
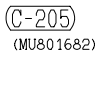
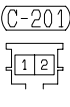
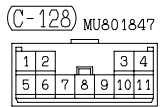
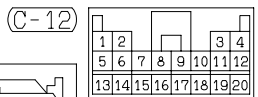
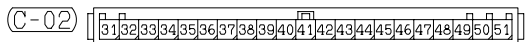
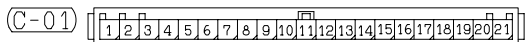
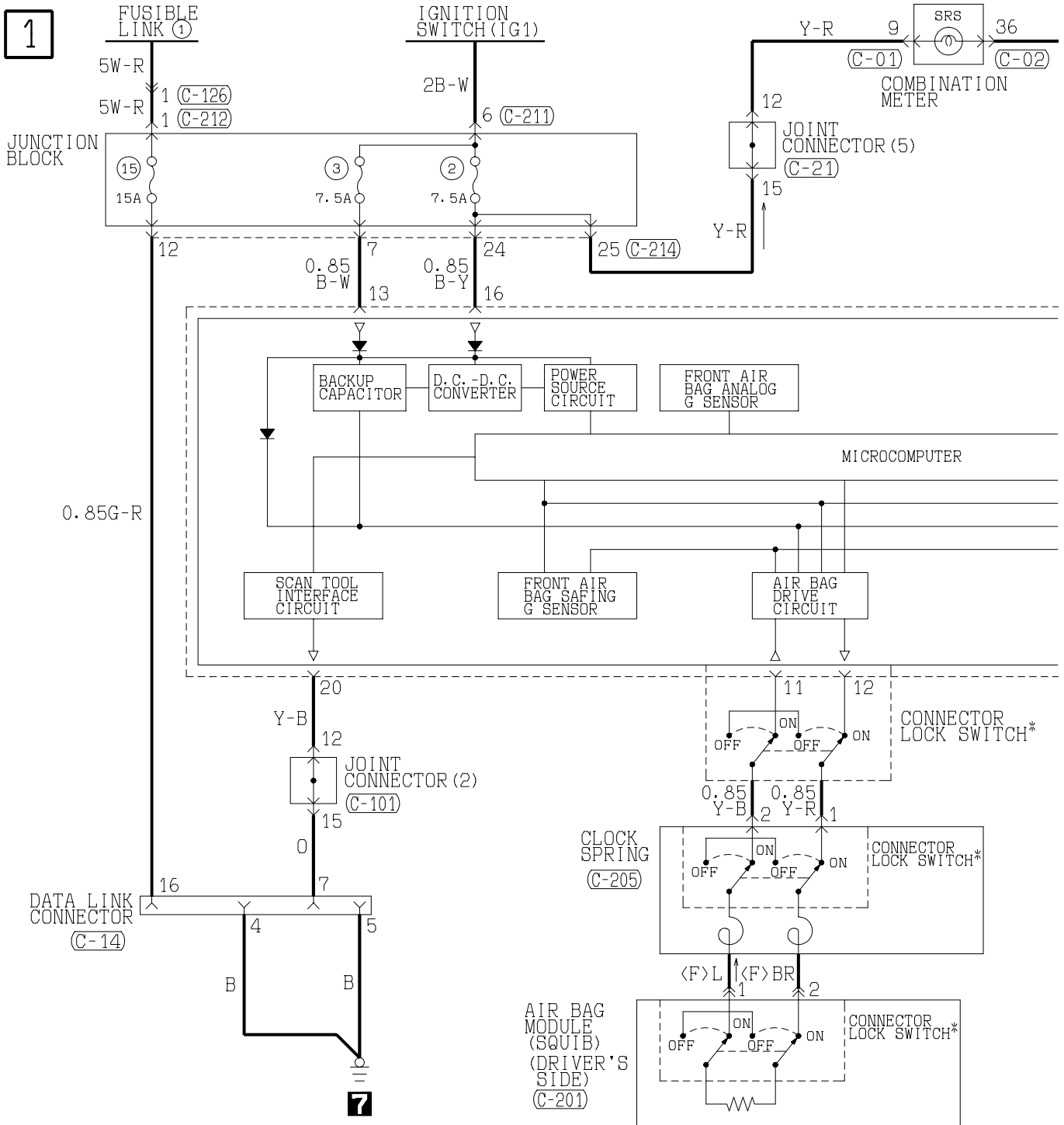

H2J15M03AA

2

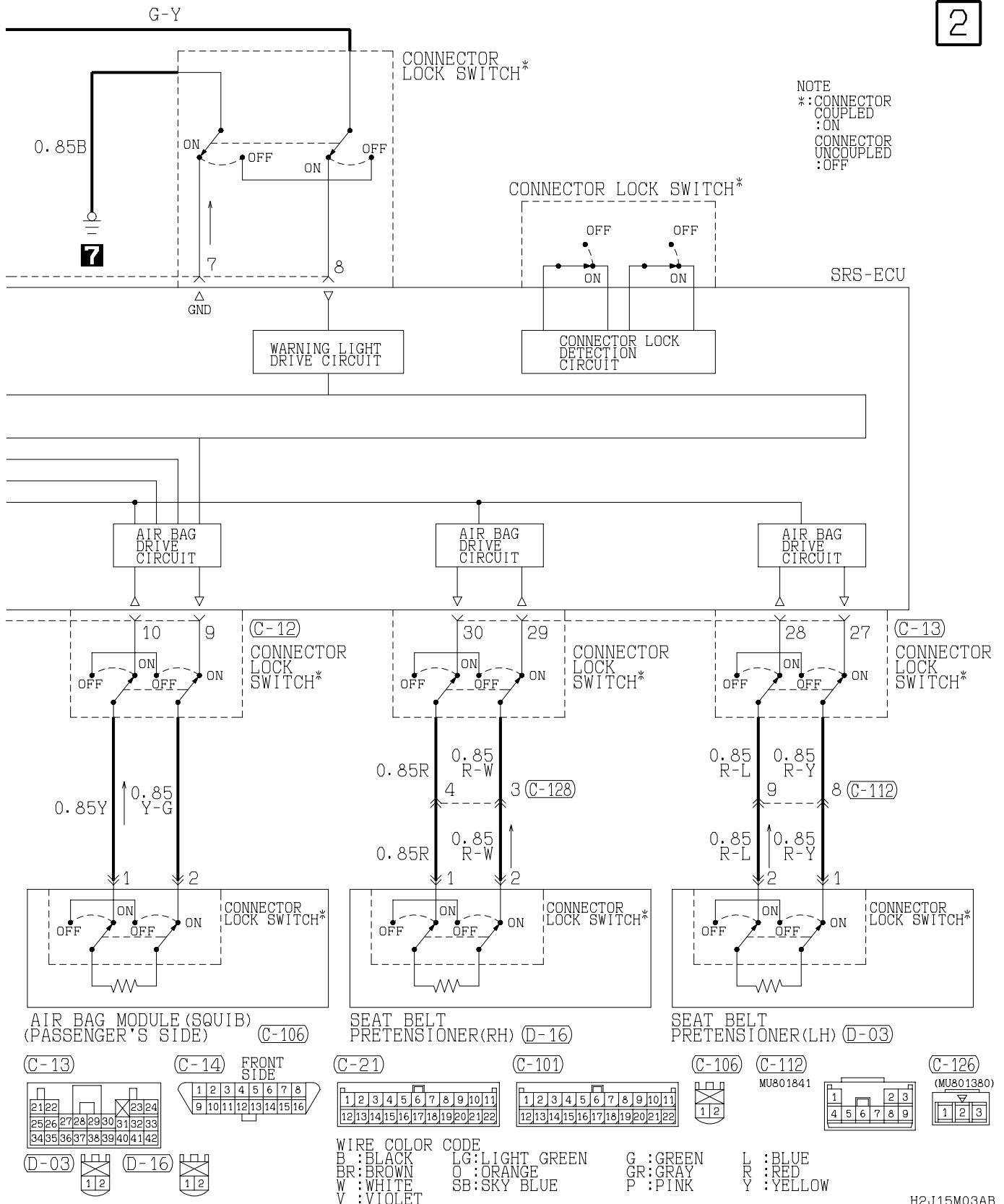

SUPPLEMENTAL RESTRAINT SYSTEM (SRS)
<VEHICLES WITH SIDE AIR BAG>

M3030009700029

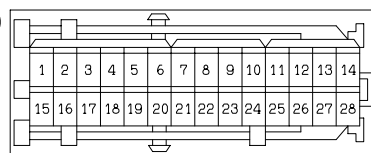
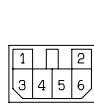
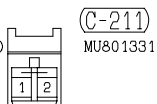
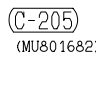
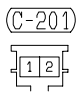
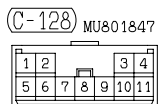
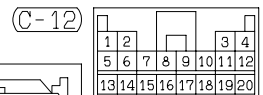
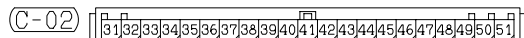
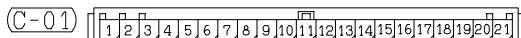
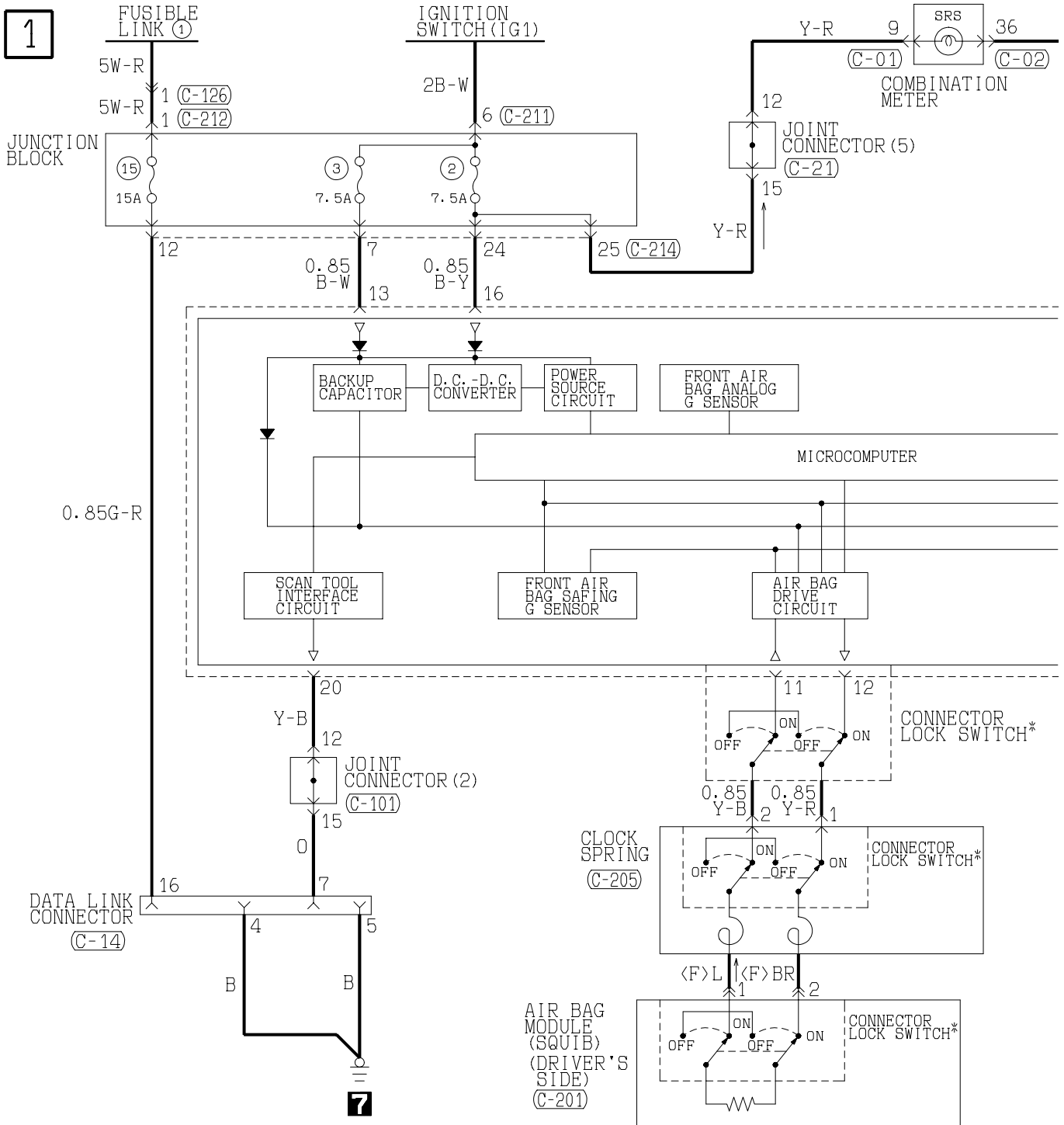

H2J15M04AA

2

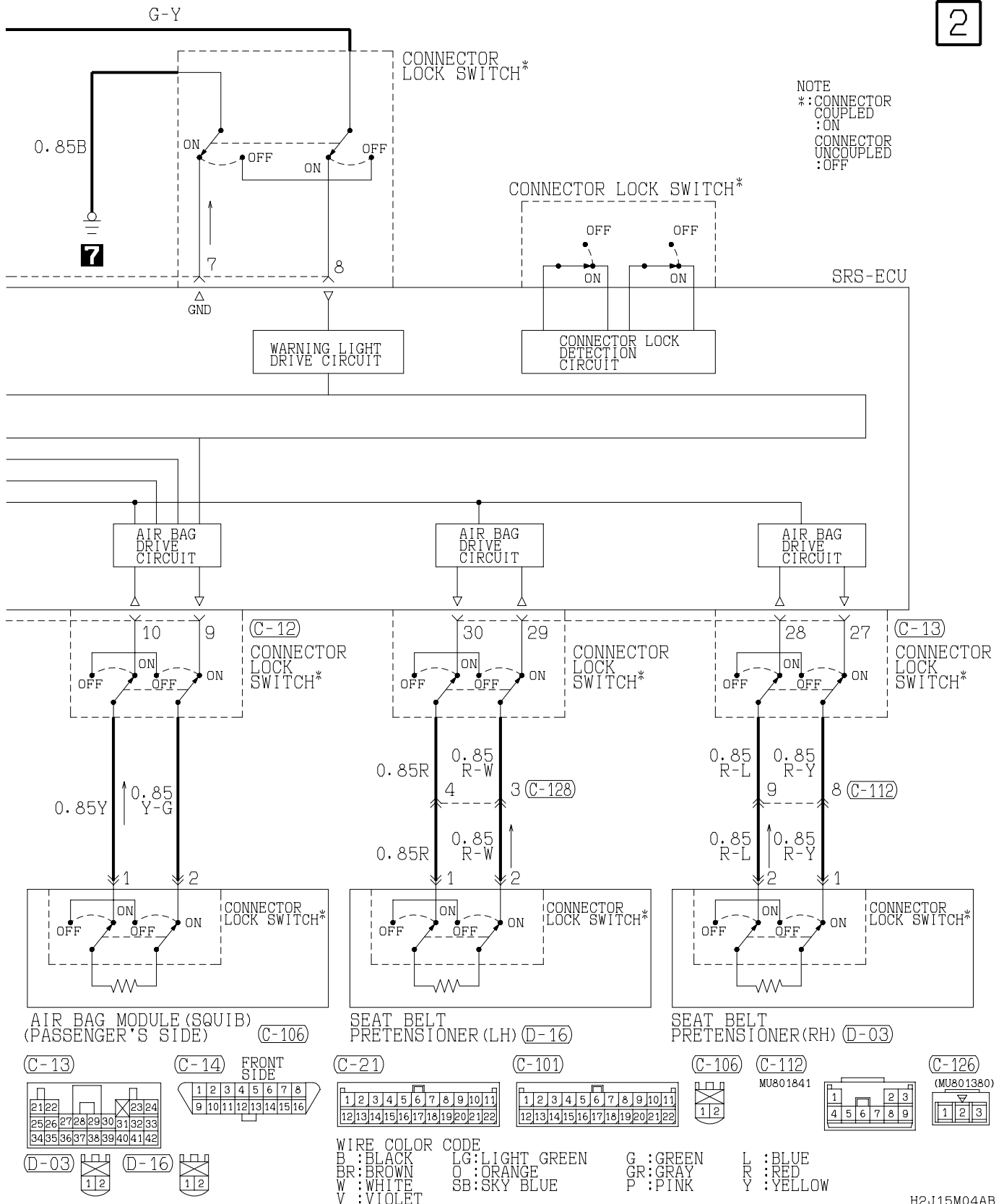

SUPPLEMENTAL RESTRAINT SYSTEM (SRS) <VEHICLES WITH SIDE AIR BAG>
(CONTINUED)

3

NOTE
*: CONNECTOR
COUPLED: ON
CONNECTOR
UNCOUPLED: OFF

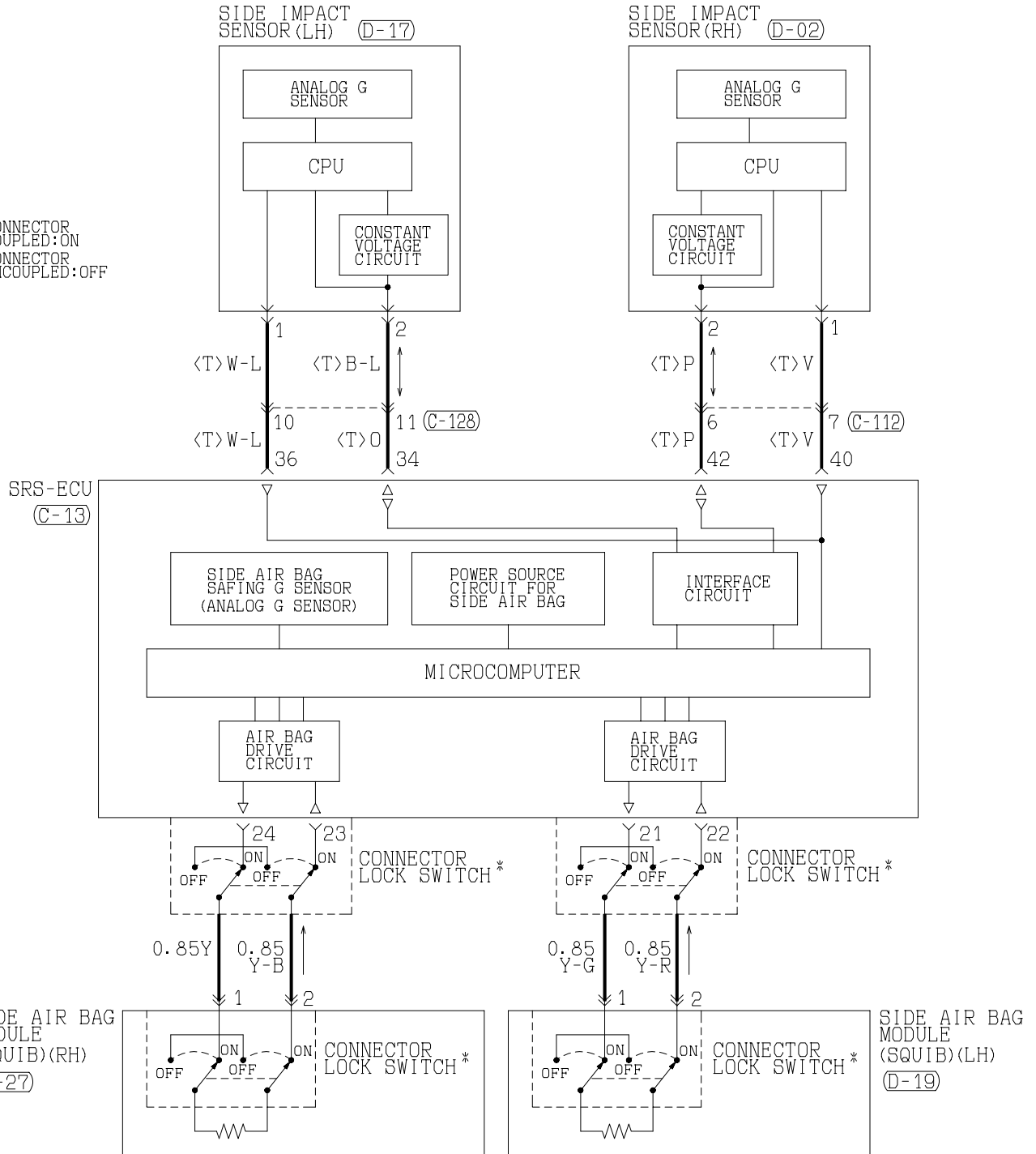

(C-13)

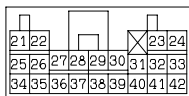

(C-112)

MU801841

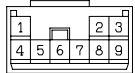

(C-128)

MU801847

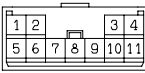

(D-02)



(D-17)



(D-19)



(D-27)



WIRE COLOR CODE
 B : BLACK LG : LIGHT GREEN G : GREEN L : BLUE W : WHITE Y : YELLOW SB : SKY BLUE
 BR : BROWN O : ORANGE GR : GRAY R : RED P : PINK V : VIOLET

NOTES

LIGHTING MONITOR TONE ALARM

M3030011400014

1

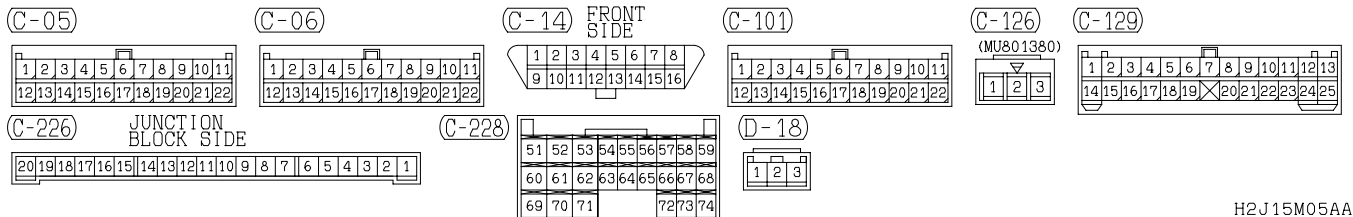
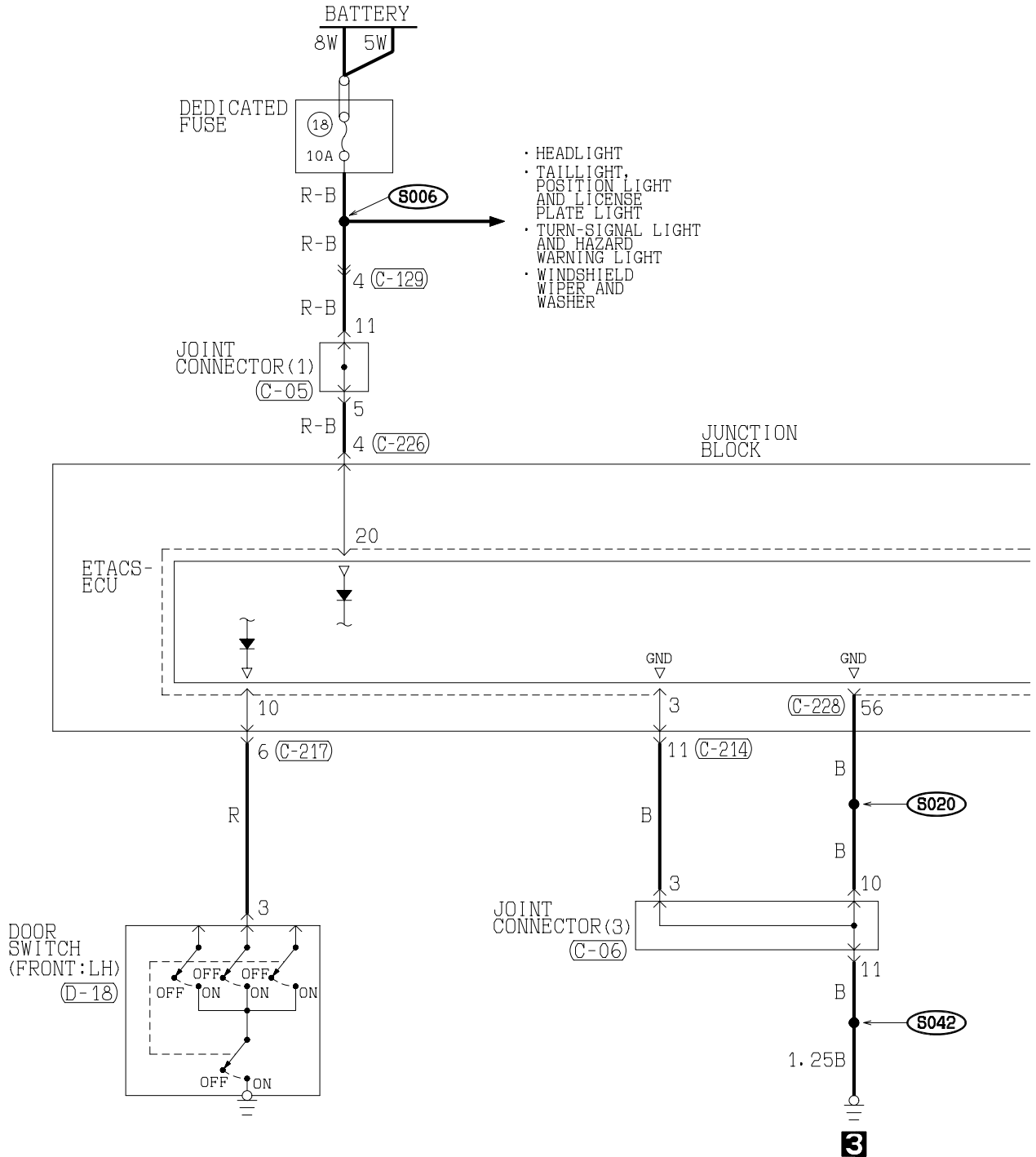

H2J15M05AA

2

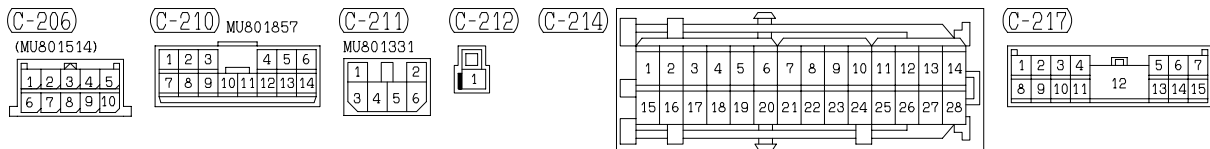
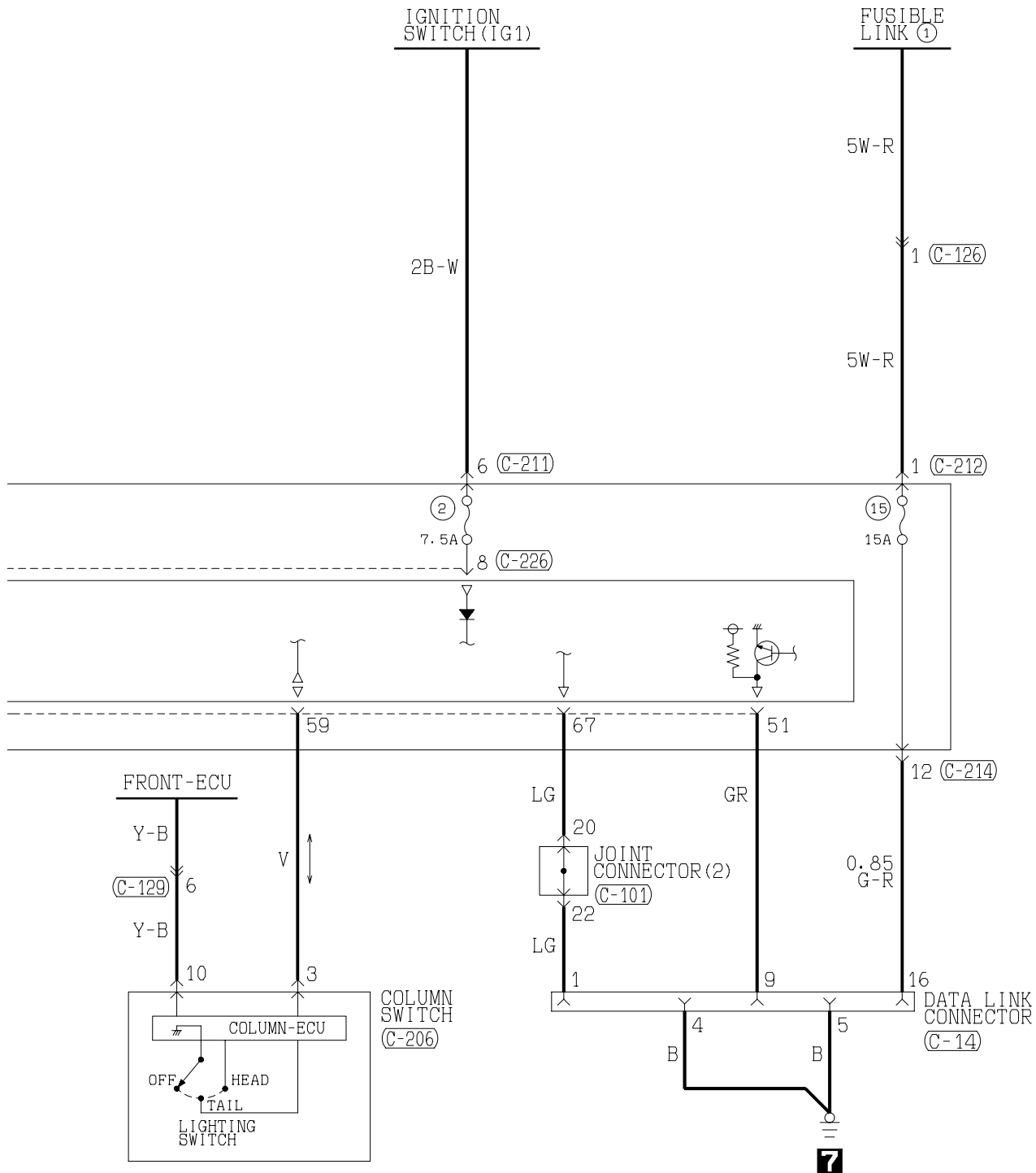

WIRE COLOR CODE
 B : BLACK LG : LIGHT GREEN G : GREEN L : BLUE W : WHITE Y : YELLOW SB : SKY BLUE
 BR : BROWN O : ORANGE GR : GRAY R : RED P : PINK V : VIOLET

KEY REMINDER TONE ALARM

M3030011300028

1

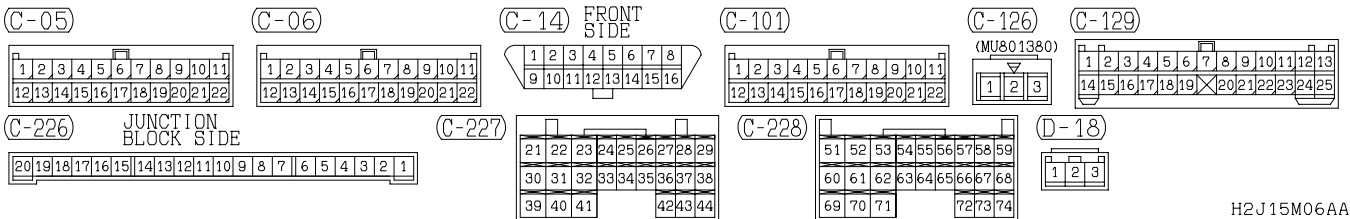
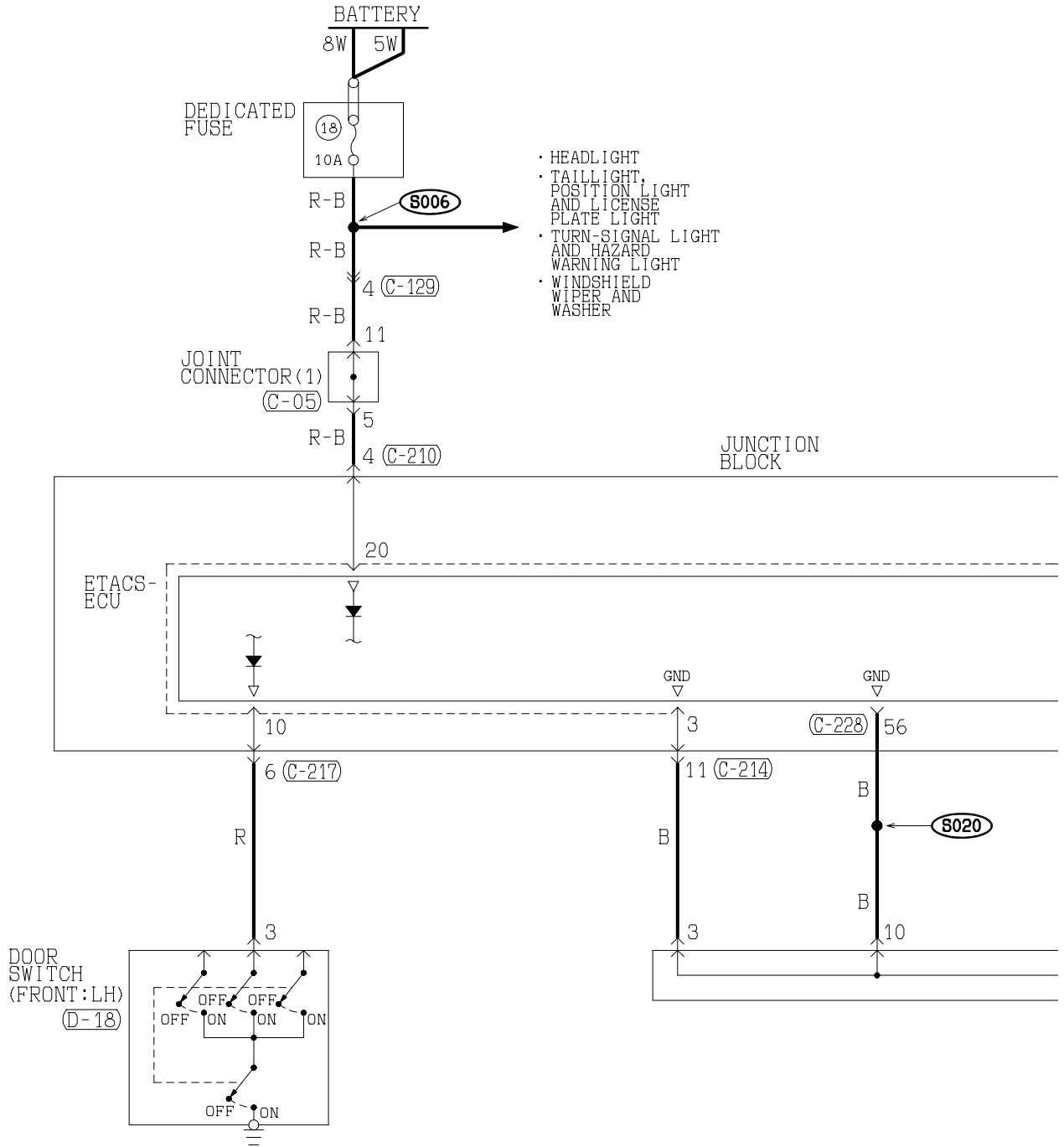

H2J15M06AA

TSB Revision

2

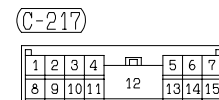
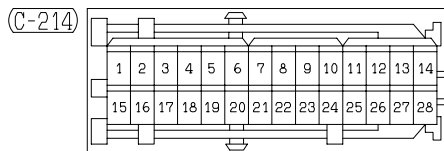
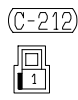
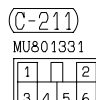
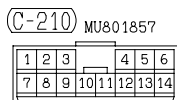
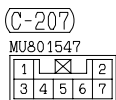
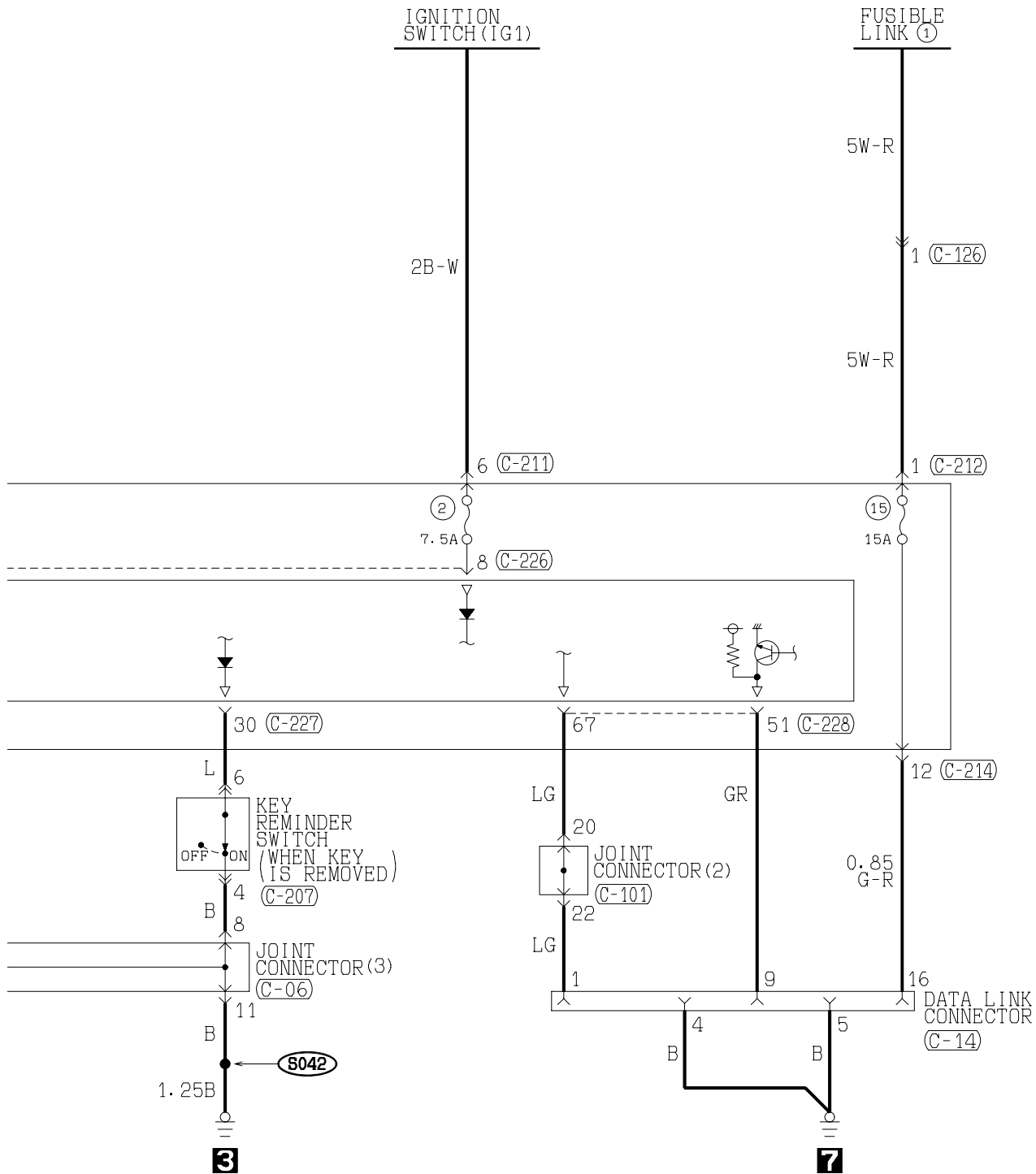

WIRE COLOR CODE
 B : BLACK LG : LIGHT GREEN G : GREEN L : BLUE W : WHITE Y : YELLOW SB : SKY BLUE
 BR : BROWN O : ORANGE GR : GRAY R : RED P : PINK V : VIOLET

SEAT BELT TONE ALARM

1

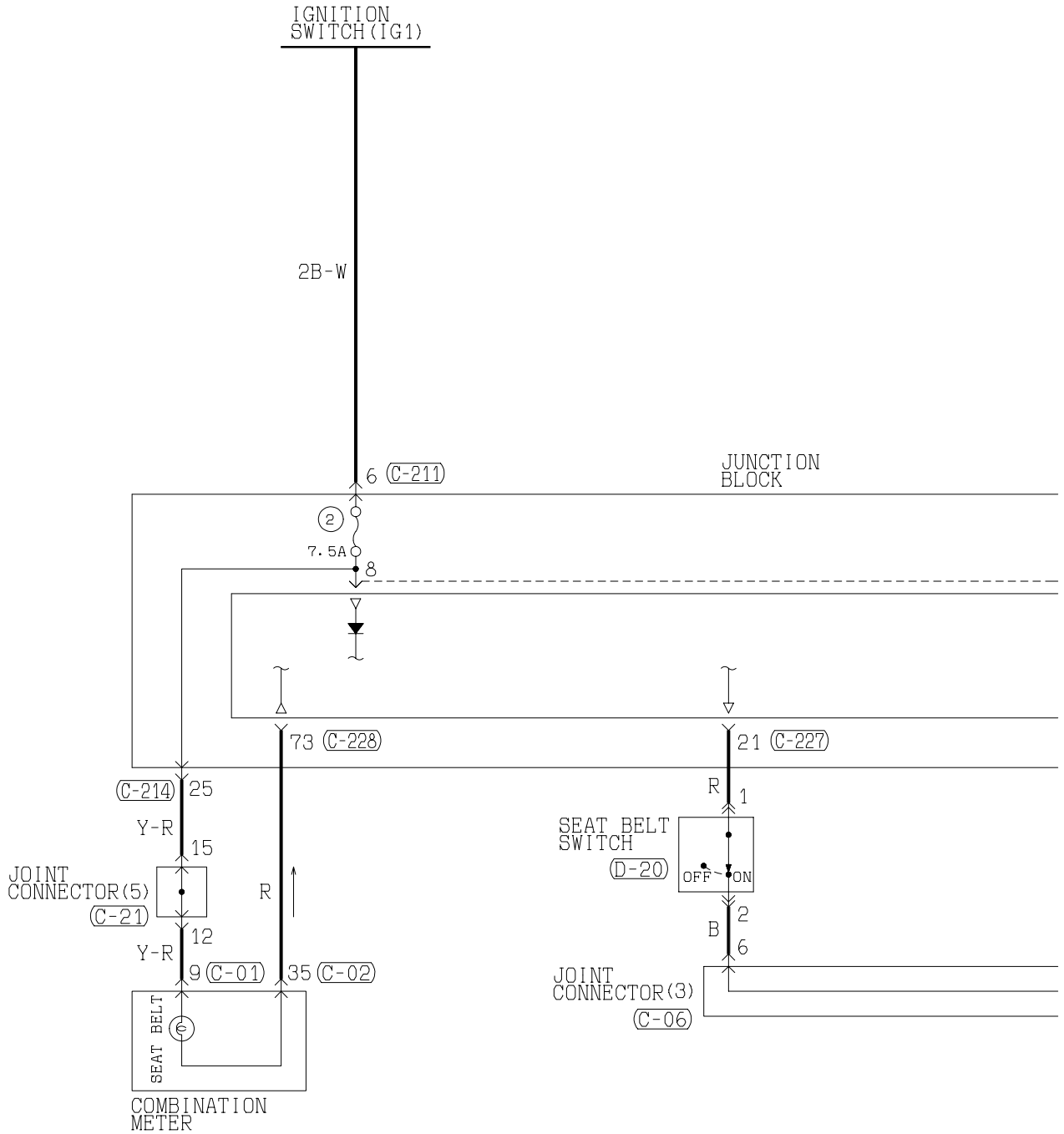

(C-01)

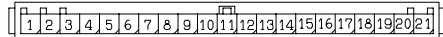

(C-02)

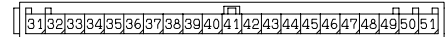

(C-05)

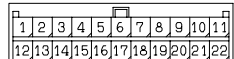

(C-06)

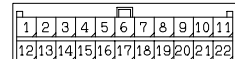

(C-14)

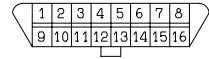

(C-21)

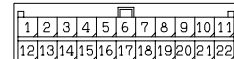

(C-101)

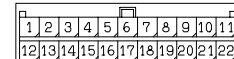

(C-126)

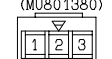

(C-226)

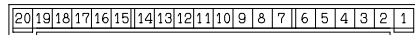

JUNCTION
BLOCK SIDE

(C-227)

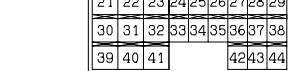

(C-228)

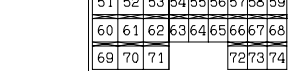

(D-20)



2

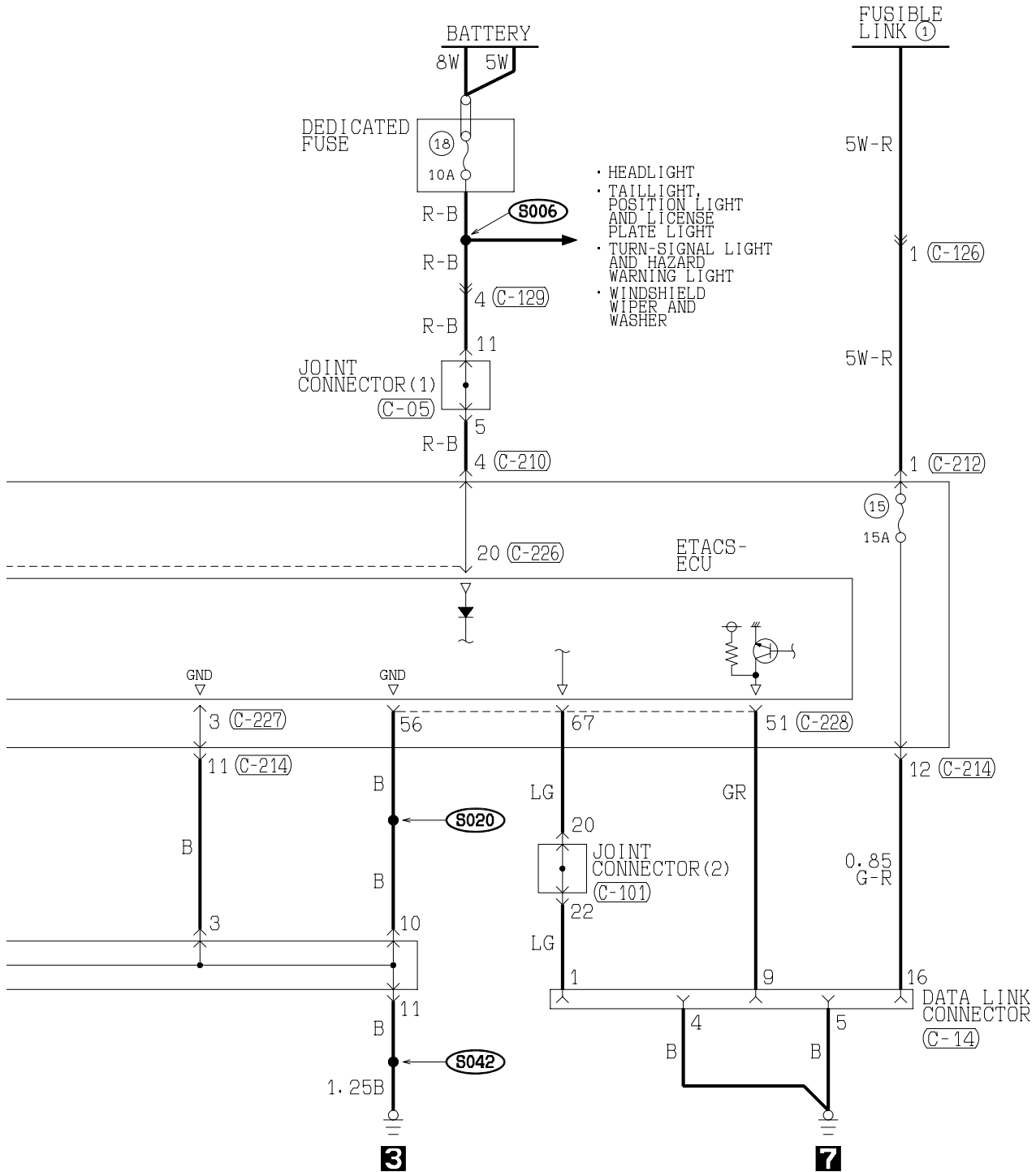

(C-129)

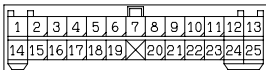

(C-210) MU801857

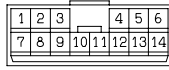

(C-211) MU801331



(C-212)



(C-214)

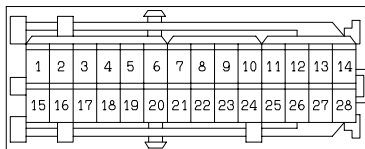

WIRE COLOR CODE

B : BLACK LG : LIGHT GREEN
BR : BROWN O : ORANGE

G : GREEN GR : GRAY

L : BLUE R : RED

W : WHITE P : PINK

Y : YELLOW V : VIOLET

SB : SKY BLUE

RHEOSTAT

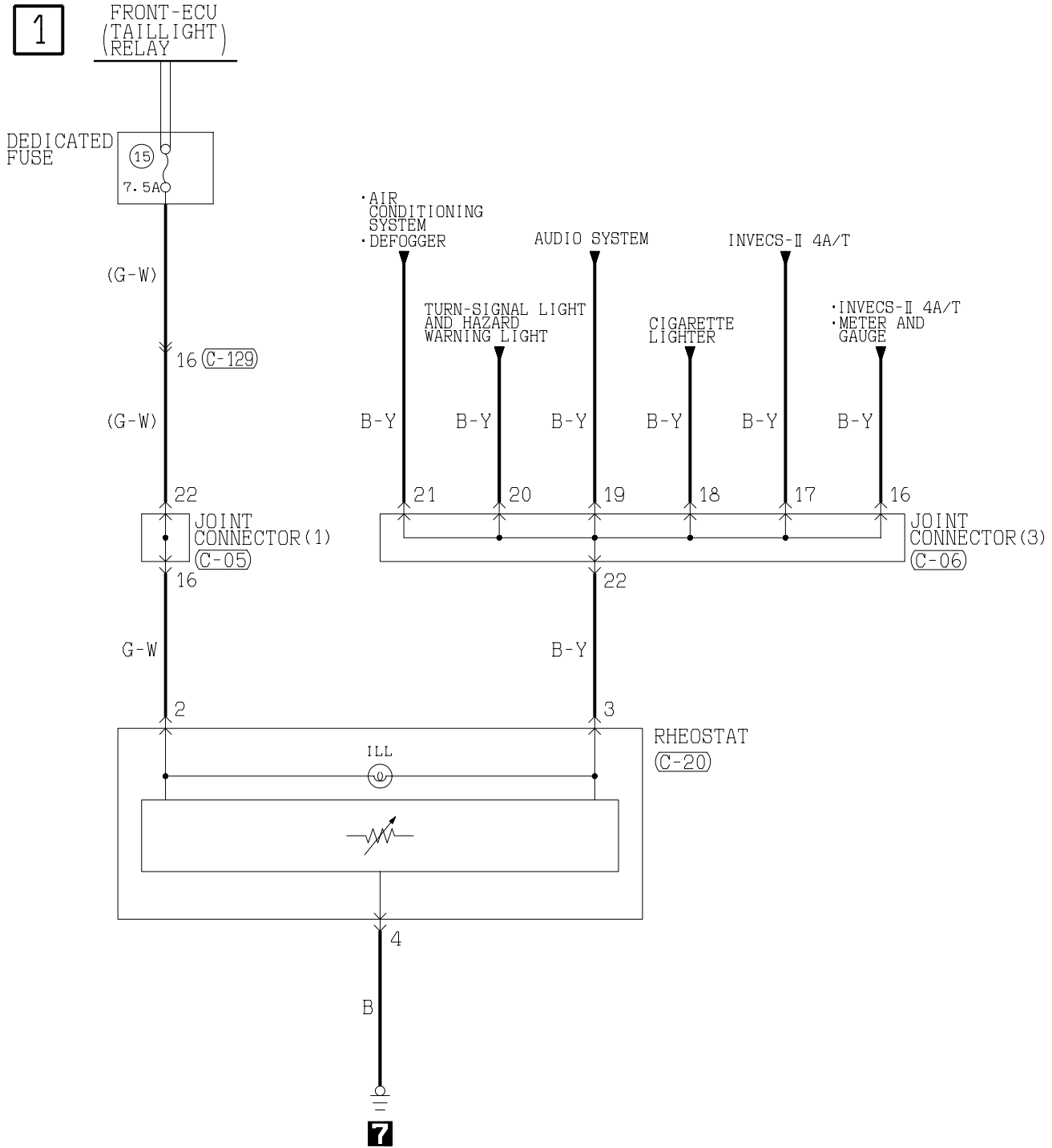

(C-05)

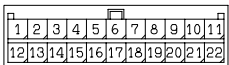

(C-06)

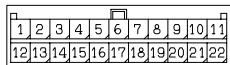

(C-20)

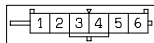

(C-129)

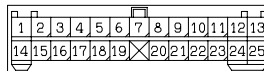

WIRE COLOR CODE
 B : BLACK LG : LIGHT GREEN G : GREEN L : BLUE W : WHITE Y : YELLOW SB : SKY BLUE
 BR : BROWN O : ORANGE GR : GRAY R : RED P : PINK V : VIOLET