

*TODAY'S TECHNICIAN™*

# AUTOMOTIVE ELECTRICITY & ELECTRONICS

5TH EDITION

CLASSROOM MANUAL



We Support  
ASE Program Certification  
Through



**BARRY HOLLEMBEAK**

***TODAY'S TECHNICIAN***™

**CLASSROOM MANUAL** FOR  
**AUTOMOTIVE ELECTRICITY  
AND ELECTRONICS**

**FIFTH EDITION**

**BARRY HOLLEMBEAK**





**Today's Technician™: Automotive Electricity and Electronics, 5th Edition**

Barry Hollembeak

Vice President, Career and Professional  
Editorial: Dave Garza

Director of Learning Solutions: Sandy Clark

Executive Editor: David Boelio

Managing Editor: Larry Main

Senior Product Manager: Matthew Thouin

Editorial Assistant: Jillian Borden

Vice President, Career and Professional  
Marketing: Jennifer McAvey

Marketing Director: Deborah S. Yarnell

Marketing Manager: Katie Hall

Associate Marketing Manager: Mark Pierro

Production Director: Wendy Troeger

Production Manager: Mark Bernard

Content Project Manager: Cheri Plasse

Art Director: Benj Gleeksman

© 2011 Delmar, Cengage Learning

ALL RIGHTS RESERVED. No part of this work covered by the copyright herein may be reproduced, transmitted, stored, or used in any form or by any means graphic, electronic, or mechanical, including but not limited to photocopying, recording, scanning, digitizing, taping, Web distribution, information networks, or information storage and retrieval systems, except as permitted under Section 107 or 108 of the 1976 United States Copyright Act, without the prior written permission of the publisher.

For product information and technology assistance, contact us at  
**Professional Group Cengage Learning Customer & Sales Support, 1-800-354-9706**

For permission to use material from this text or product,  
submit all requests online at **[cengage.com/permissions](http://cengage.com/permissions)**.

Further permissions questions can be e-mailed to  
**[permissionrequest@cengage.com](mailto:permissionrequest@cengage.com)**.

Library of Congress Control Number: 2010923010

ISBN-13: 978-1-4354-7008-8

ISBN-10: 1-4354-7008-7

**Delmar**

5 Maxwell Drive

Clifton Park, NY 12065-2919

USA

Cengage Learning is a leading provider of customized learning solutions with office locations around the globe, including Singapore, the United Kingdom, Australia, Mexico, Brazil and Japan. Locate your local office at:

**[international.cengage.com/region](http://international.cengage.com/region)**

Cengage Learning products are represented in Canada by Nelson Education, Ltd.

For your lifelong learning solutions, visit **[delmar.cengage.com](http://delmar.cengage.com)**Visit our corporate website at **[cengage.com](http://cengage.com)**.**Notice to the Reader**

Publisher does not warrant or guarantee any of the products described herein or perform any independent analysis in connection with any of the product information contained herein. Publisher does not assume, and expressly disclaims, any obligation to obtain and include information other than that provided to it by the manufacturer. The reader is expressly warned to consider and adopt all safety precautions that might be indicated by the activities described herein and to avoid all potential hazards. By following the instructions contained herein, the reader willingly assumes all risks in connection with such instructions. The publisher makes no representations or warranties of any kind, including but not limited to, the warranties of fitness for particular purpose or merchantability, nor are any such representations implied with respect to the material set forth herein, and the publisher takes no responsibility with respect to such material. The publisher shall not be liable for any special, consequential, or exemplary damages resulting, in whole or part, from the readers' use of, or reliance upon, this material.

# CONTENTS

---

<b>Preface</b> .....	<b>vi</b>
<b>CHAPTER 1 Introduction to Automotive Electrical and Electronic Systems</b> .....	<b>1</b>
• Introduction 1 • Why Become an Electrical System Technician? 1 • The Role of Electricity in the Automobile 2 • Introduction to the Electrical Systems 2 • Summary 14 • Terms to Know 14 • Review Questions 15 • Multiple Choice 15	
<b>CHAPTER 2 Basic Theories</b> .....	<b>17</b>
• Introduction 17 • Basics of Electron Flow 17 • Electricity Defined 20 • Electrical Laws 24 • Types of Current 27 • Electrical Circuits 28 • Kirchoff's Laws 39 • Capacitance 41 • Magnetism Principles 43 • Theory of Induction 46 • EMI Suppression 47 • Summary 48 • Terms to Know 48 • Review Questions 49 • Multiple Choice 49	
<b>CHAPTER 3 Electrical and Electronic Components</b> .....	<b>51</b>
• Introduction 51 • Electrical Components 51 • Electronic Components 59 • Circuit Protection Devices 70 • Circuit Defects 75 • Summary 78 • Terms to Know 78 • Review Questions 79 • Multiple Choice 80	
<b>CHAPTER 4 Wiring and Circuit Diagrams</b> .....	<b>82</b>
• Introduction 82 • Automotive Wiring 82 • Wiring Diagrams 93 • Summary 104 • Terms to Know 105 • Review Questions 105 • Multiple Choice 106	
<b>CHAPTER 5 Automotive Batteries</b> .....	<b>108</b>
• Introduction 108 • Conventional Batteries 110 • Maintenance-Free Batteries 115 • Hybrid Batteries 117 • Recombination Batteries 118 • High-Voltage Batteries 120 • Ultra-Capacitors 125 • Battery Terminals 125 • Battery Ratings 126 • Battery Cables 127 • Battery Holddowns 128 • Summary 129 • Terms to Know 130 • Review Questions 131 • Multiple Choice 131	
<b>CHAPTER 6 Starting Systems and Motor Designs</b> .....	<b>133</b>
• Introduction 133 • Direct-Current Motor Principles 133 • Dc Motor Field Winding Designs 138 • Starter Drives 142 • Cranking Motor Circuits 144 • Starter Control Circuit Components 144 • Cranking Motor Designs 152 • AC Motor Principles 156 • Integrated Starter Generator 161 • Summary 163 • Terms to Know 163 • Review Questions 164 • Multiple Choice 165	
<b>CHAPTER 7 Charging Systems</b> .....	<b>166</b>
• Introduction 166 • Principle of Operation 167 • AC Generators 169 • AC Generator Circuits 179 • AC Generator Operation Overview 180 • Regulation 183 • Charging Indicators 191 • AC Generator Design Differences 193 • HEV Charging Systems 201 • Summary 205 • Terms to Know 206 • Review Questions 206 • Multiple Choice 207	
<b>CHAPTER 8 Lighting Circuits</b> .....	<b>208</b>
• Introduction 208 • Lamps 209 • Headlights 210 • Headlight Switches 214 • Concealed Headlights 217 • Flash to Pass 220 • Exterior Lights 220 • Interior Lights 235 • Summary 237 • Terms to Know 237 • Review Questions 238 • Multiple Choice 239	

<b>CHAPTER 9</b>	<b><i>Introduction to the Body Computer</i></b> . . . . .	<b>240</b>
	• Introduction 240 • Computer Functions 240 • Analog and Digital Principles 241	
	• Microprocessor 245 • Computer Memory 245 • Information Processing 248 • High-Side and Low-Side Drivers 253 • Outputs 254 • Summary 257 • Terms to Know 257 • Review Questions 258	
	• Multiple Choice 259	
<b>CHAPTER 10</b>	<b><i>Computer Inputs</i></b> . . . . .	<b>260</b>
	• Introduction 260 • Thermistors 261 • Pressure Sensors 264 • Position and Motion Detection Sensors 268 • Switch Inputs 277 • Feedback Signals 279 • Summary 279 • Terms to Know 280	
	• Review Questions 281 • Multiple Choice 281	
<b>CHAPTER 11</b>	<b><i>Vehicle Communication Networks</i></b> . . . . .	<b>283</b>
	• Introduction 283 • Multiplexing Communication Protocols 284 • Multiplexing Systems 286	
	• Supplemental Data Bus Networks 297 • Summary 302 • Terms to Know 302 • Review Questions 303 • Multiple Choice 304	
<b>CHAPTER 12</b>	<b><i>Advanced Lighting Circuits</i></b> . . . . .	<b>305</b>
	• Introduction 305 • Computer-Controlled Concealed Headlights 305 • Computer-Controlled Headlight Systems 307 • Automatic On/Off with Time Delay 309 • Automatic Headlight Dimming 313 • Headlight Leveling 318 • Adaptive Headlights 318 • Daytime Running Lamps 320	
	• Adaptive Brake Lights 322 • Illuminated Entry Systems 323 • Instrument Panel Dimming 324	
	• Fiber Optics 326 • Lamp Outage Indicators 327 • Summary 331 • Terms to Know 331 • Review Questions 332 • Multiple Choice 332	
<b>CHAPTER 13</b>	<b><i>Instrumentation and Warning Lamps</i></b> . . . . .	<b>334</b>
	• Introduction 334 • Electromechanical Gauges 335 • Quartz Analog Instrumentation 339 • Gauge Sending Units 341 • Digital Instrumentation 342 • Head-Up Display 349 • Travel Information Systems 350 • Warning Lamps 353 • Summary 355 • Terms to Know 355 • Review Questions 355	
	• Multiple Choice 356	
<b>CHAPTER 14</b>	<b><i>Accessories</i></b> . . . . .	<b>358</b>
	• Introduction 358 • Horns 359 • Windshield Wipers 363 • Computer-Operated Wipers 374	
	• Intelligent Windshield Wipers 375 • Washer Pumps 376 • Blower Motor Circuits 379 • Electric Defoggers 382 • Power Mirrors 383 • Power Windows 386 • Power Seats 389 • Memory Seats 392	
	• Power Door Locks 394 • Automatic Door Locks 398 • Keyless Entry 399 • Antitheft Systems 404	
	• Immobilizer Systems 407 • Electronic Cruise Control Systems 409 • Electronic Sunroof Concepts 412 • Electronic Heated Windshield 417 • Vehicle Audio Entertainment Systems 422	
	• DVD Systems 428 • Hands-Free Cellular Telephone 429 • Navigation Systems 430 • Summary 431	
	• Terms to Know 431 • Review Questions 432 • Multiple Choice 433	
<b>CHAPTER 15</b>	<b><i>Passive Restraint Systems</i></b> . . . . .	<b>434</b>
	• Introduction 434 • Passive Seat Belt Systems 435 • Air Bag Systems 438 • Air Bag Deployment 444	
	• Air Bag Warning Lamp 445 • Passenger-Side Air Bags 445 • Hybrid Air Bag Types 446 • Multistage Air Bag Deployment 447 • Side-Impact Air Bags 448 • Air Bag On/Off Switches 450 • Seat Belt Pretensioners 453 • Inflatable Knee Blockers 454 • Occupant Classification Systems 454	
	• Summary 459 • Terms to Know 460 • Review Questions 460 • Multiple Choice 461	

# CONTENTS

---

<b>CHAPTER 16</b>	<b><i>Vehicles with Alternative Power Sources</i></b>	<b>.463</b>			
• Introduction	463 • Electric Vehicles	463 • Hybrid Vehicles	465 • 42-Volt Systems	470	
• Fuel Cells	476 • Summary	483 • Terms to Know	483 • Review Questions	484 • Multiple Choice	485
<b><i>Glossary</i></b>					<b>.487</b>
<b><i>Index</i></b>					<b>.515</b>

Thanks to the support the *Today's Technician*<sup>™</sup> series has received from those who teach automotive technology, Delmar Cengage Learning, the leader in automotive related textbooks, is able to live up to its promise to provide new editions of the series every few years. We have listened and responded to our critics and our fans and present this new updated and revised fifth edition. By revising this series on a regular basis, we can respond to changes in the industry, changes in technology, changes in the certification process, and to the ever-changing needs of those who teach automotive technology.

We also listened to instructors when they said something was missing or incomplete in the last edition. We responded to those and the results are included in this fifth edition.

The *Today's Technician*<sup>™</sup> series, by Delmar Cengage, features textbooks that cover all mechanical and electrical systems of automobiles and light trucks. Principally the individual titles correspond to the certification areas for 2009 areas of ASE (National Institute for Automotive Service Excellence) certification.

Additional titles include remedial skills and theories common to all of the certification areas and advanced or specific subject areas that reflect the latest technological trends.

This new edition, like the last, was designed to give students a chance to develop the same skills and gain the same knowledge that today's successful technician has. This edition also reflects the changes in the guidelines established by the National Automotive Technicians Education Foundation (NATEF) in 2008.

The purpose of NATEF is to evaluate technician training programs against standards developed by the automotive industry and recommend qualifying programs for certification (accreditation) by ASE. Programs can earn ASE certification upon the recommendation of NATEF. NATEF's national standards reflect the skills that students must master. ASE certification through NATEF evaluation ensures that certified training programs meet or exceed industry-recognized, uniform standards of excellence.

The technician of today and for the future must know the underlying theory of all automotive systems and be able to service and maintain those systems. Dividing the material into two volumes, a Classroom Manual and a Shop Manual, provides the reader with the information needed to begin a successful career as an automotive technician without interrupting the learning process by mixing cognitive and performance learning objectives into one volume.

The design of Delmar's *Today's Technician*<sup>™</sup> series was based on features that are known to promote improved student learning. The design was further enhanced by a careful study of survey results, in which the respondents were asked to value particular features. Some of these features can be found in other textbooks, while others are unique to this series.

Each Classroom Manual contains the principles of operation for each system and subsystem. The Classroom Manual also contains discussions on design variations of key components used by the different vehicle manufacturers. It also looks into emerging technologies that will be standard or optional features in the near future. This volume is organized to build upon basic facts and theories. The primary objective of this volume is to allow the reader to gain an understanding of how each system and subsystem operates. This understanding is necessary to diagnose the complex automobiles of today and tomorrow. Although the basics contained in the Classroom Manual provide the knowledge needed for diagnostics, diagnostic procedures appear only in the Shop Manual. An understanding of the underlying theories is also a requirement for competence in the skill areas covered in the Shop Manual.

A coil ring—bound Shop Manual covers the “how-to’s.” This volume includes step-by-step instructions for diagnostic and repair procedures. Photo Sequences are used to illustrate some of the common service procedures. Other common procedures are listed and are accompanied with fine line drawings and photos that allow the reader to visualize and conceptualize the finest details of the procedure. This volume also contains the reasons for performing the procedures, as well as when that particular service is appropriate.

The two volumes are designed to be used together and are arranged in corresponding chapters. Not only are the chapters in the volumes linked together, the contents of the chapters are also linked. This linking of content is evidenced by marginal callouts that refer the reader to the chapter and page that the same topic is addressed in the other volume. This feature is valuable to instructors. Without this feature, users of other two-volume textbooks must search the index or table of contents to locate supporting information in the other volume. This is not only cumbersome, but also creates additional work for an instructor when planning the presentation of material and when making reading assignments. It is also valuable to the students, with the page references they also know exactly where to look for supportive information.

Both volumes contain clear and thoughtfully selected illustrations. Many of which are original drawings or photos specially prepared for inclusion in this series. This means that the art is a vital part of each textbook and not merely inserted to increase the numbers of illustrations.

The page layout, used in the series, is designed to include information that would otherwise break up the flow of information presented to the reader. The main body of the text includes all of the “need-to-know” information and illustrations. In the wide side margins of each page are many of the special features of the series. Items that are truly “nice-to-know” information such as simple examples of concepts just introduced in the text, explanations or definitions of terms that are not defined in the text, examples of common trade jargon used to describe a part or operation, and exceptions to the norm are explained in the text. This type of information is placed in the margin, out of the normal flow of information. Many textbooks attempt to include this type of information and insert it in the main body of text; this tends to interrupt the thought process and cannot be pedagogically justified. By placing this information off to the side of the main text, the reader can select when to refer to it.

### **HIGHLIGHTS OF THIS EDITION—CLASSROOM MANUAL**

Upon opening the covers of the 5th Edition of *Today’s Technician Automotive Electricity and Electronics*, you will immediately notice the use of colored photos and illustrations that greatly enhance the visual quality of the text and the learning experience of the student. The text layout has also been improved for easier reader comprehension.

Not only does the textbook have a fresh look, the text of the 5th Edition was updated throughout to include the latest developments. Although chapter 16 covers details associated with alternate powered vehicles, all pertinent information about hybrid vehicles is included in the main text that concerns relative topics. For example, the discussion of batteries in Chapter 5 includes coverage of HEV batteries and ultra-capacitors. Chapter 6 now includes AC motor principles and the operation of the integrated starter/generator. Chapter 7 includes the HEV charging system including regenerative braking and the DC/DC converter.

The flow of basic electrical to more complex electronic systems has been maintained. Rearrangement of chapters has been utilized to enhance this flow and reduce redundancy.

Chapter 1 introduces the student to the automotive electrical and electronic systems with a general overview. This chapter emphasizes the interconnectivity of systems in today's vehicles, and describes the purpose and location of the subsystems, as well as the major components of the system and subsystems. The goal of this chapter is to establish a basic understanding for students to base their learning on. All systems and subsystems that are discussed in detail later in the text are introduced and their primary purpose described. The second chapter covers the underlying basic theories of electricity and now includes discussion of Kirchoff's laws. This is valuable to the student and the instructor because it covers the theories that other textbooks assume the reader knows. All related basic electrical theories are covered in this chapter.

Chapter 3 applies those theories to the operation of electrical and electronic components, and Chapter 4 covers wiring and the proper use of wiring diagrams. Emphasis is on using the diagrams to determine how the system works and how to use the diagram to isolate the problem.

The chapters that follow cover the major components of automotive electrical and electronic systems, such as batteries, starting systems and motor designs, charging systems, and basic lighting systems. This is followed by chapters that detail the functions of the body computer, input components, and vehicle communication networks. From here the student is guided into specific systems that utilize computer functions.

Current electrical and electronic systems are used as examples throughout the text. Most of these systems are discussed in detail. This includes computer-controlled interior and exterior lighting, night vision, adaptive lights, instrumentation, and electrical/electronic accessories. Coverage includes intelligent wiper, immobilizer, and adaptive cruise control systems to name a few. Chapter 15 details the passive restraint systems currently used.

Jack Erjavec

### **HIGHLIGHTS OF THIS EDITION—SHOP MANUAL**

Like the Classroom Manual, the Shop Manual has a new layout with color photographs and illustrations. The Shop Manual was updated to match current trends. Service information related to the new topics covered in the Classroom Manual is included in this manual. In addition, several new photo sequences were added. The purpose of these detailed photos is to show students what to expect when they perform the same procedure. They also help familiarize students with a system or type of equipment they may not be able to encounter at their school. Although the main purpose of the textbook is not to prepare someone to successfully pass an ASE exam, all the information required to do so is included in the textbook.

To stress the importance of safe work habits, Chapter 1 is dedicated to safety, and has been updated to include general HEV safety. As with the Classroom Manual, HEV system diagnosis is included within the main text. This provides the student with knowledge of safe system diagnosing procedures so they know what to expect as they further their training in this area. Included in this chapter are common shop hazards, safe shop practices, safety equipment, and the legislation concerning and the safe handling of hazardous materials and wastes.

Chapter 2 covers special tools and procedures. This chapter now includes the use of isolation meters and expanded coverage of scan tools. In addition, a section on what it entails to be an electrical systems technician has been added. This section covers relationships, completing the



## PREFACE

---

work order and ASE certification. Another section was added to emphasize the importance of proper diagnostic procedures.

Chapter 3 leads the student through basic troubleshooting and service. This includes the use of various test equipment to locate circuit defects and how to test electrical and electronic components. Chapter 4 provides experience with wiring repairs along with extended coverage and exercises on using the wiring diagrams.

The remainder of the chapters has been thoroughly updated. Redundancy between the Classroom Manual and the Shop Manual has been reduced; the only time theory is discussed again is if it is necessary to explain the diagnostic results or as an explanation of the symptom. The Shop Manual is cross-referenced to the Classroom Manual by the use of marginal notes. This provides the benefit to the student of being able to quickly reference the theory of the component or system that they are now working with.

Currently accepted service procedures are used as examples throughout the text. These procedures also served as the basis for new job sheets that are included in the Shop Manual chapters.



Features of this manual include:

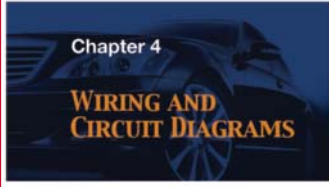
## COGNITIVE OBJECTIVES

These objectives define the contents of the chapter and define what the student should have learned upon completion of the chapter.

*Each topic is divided into small units to promote easier understanding and learning.*

## CROSS-REFERENCES TO THE SHOP MANUAL

Reference to the appropriate page in the Shop Manual is given whenever necessary. Although the chapters of the two manuals are synchronized, material covered in other chapters of the Shop Manual may be fundamental to the topic discussed in the Classroom Manual.



**Chapter 4**  
**WIRING AND CIRCUIT DIAGRAMS**

**UPON COMPLETION AND REVIEW OF THIS CHAPTER, YOU SHOULD BE ABLE TO UNDERSTAND AND DESCRIBE:**

- When single-stranded or multistranded wire should be used.
- The use of resistive wires in a circuit.
- The construction of spark plug wires.
- How wire size is determined by the American Wire Gauge (AWG) and metric methods.
- How to determine the correct wire gauge to be used in a circuit.
- How temperature affects resistance and wire size selection.
- The purpose and use of printed circuits.
- Why wiring harnesses are used and how they are constructed.
- The purpose of wiring diagrams.
- The common electrical symbols that are used.
- The purpose of the component locator.

**INTRODUCTION**  
Today's vehicles have a vast amount of electrical wiring that, if laid end to end, could stretch for half a mile or more. Today's technician must be proficient at reading wiring diagrams in order to sort through this great maze of wires. Trying to locate the cause of an electrical problem can be quite difficult if you do not have a good understanding of wiring systems and diagrams.

In this chapter, you will learn how wiring harnesses are made (Figure 4-1) how to read the wiring diagram, how to interpret the symbols used, and how terminals are used. This will reduce the amount of confusion you may experience when repairing an electrical circuit. It is also important to understand how to determine the correct type and size of wire to carry the anticipated amount of current. It is possible to cause an electrical problem by simply using the wrong gauge size of wire. A technician must understand the three factors that cause resistance in a wire—length, diameter, and temperature—to perform repairs correctly.

**AUTOMOTIVE WIRING**  
**Primary wiring** is the term used for conductors that carry low voltage. The insulation of primary wires is usually thin. **Secondary wiring** refers to wires used to carry high voltage, such as ignition spark plug wires. Secondary wires have extra-thick insulation.


Most of the primary wiring conductors used in the automobile are made of several strands of copper wire wound together and covered with a polyvinyl chloride (PVC) insulation (Figure 4-2). Copper has low resistance and can be connected to easily by using crimping connectors or soldered connections. Other types of conductor materials used in automobiles include silver, gold, aluminum, and tin-plated brass.

**Shop Manual**  
Chapter 4, page 140


82

## MARGINAL NOTES

These notes add “nice-to-know” information to the discussion. They may include examples or exceptions, or may give the common trade jargon for a component.



**FIGURE 4-14** Simple wiring harness.



**FIGURE 4-15** Flexible conduit used to make wiring harnesses.

The conduit is commonly referred to as the **wire loom** or **conduit loom**.

(Figure 4-14). A complex harness serves many circuits. The simple harness services only a few circuits. Some individual circuit wires may branch out of a complex harness to other areas of the vehicle.

Most wiring harnesses now use a flexible conduit to provide for quick wire installation (Figure 4-15). The conduit has a seam that can be opened to accommodate the installation or removal of wires from the harness. The seam will close once the wires are installed, and will remain closed even if the conduit is bent.

**Wiring Protective Devices**  
Often overlooked, but very important to the electrical system, are proper wire protection devices (Figure 4-16). These devices prevent damage to the wiring by maintaining proper wire routing and retention. Special clips, retainers, straps, and supplementary insulators provide additional protection to the conductor over what the insulation itself is capable of providing. Whenever the technician must remove one of these devices to perform a repair, it is important that the device be reinstalled to prevent additional electrical problems.

Whenever it is necessary to install additional electrical accessories, try to support the primary wire in at least 1-foot intervals. If the wire must be routed through the frame or body, use rubber grommets to protect the wire.

83

## A BIT OF HISTORY

This feature gives the student a sense of the evolution of the automobile. This feature not only contains nice-to-know information, but also should spark some interest in the subject matter.

## SUMMARIES

Each chapter concludes with a summary of key points from the chapter. These are designed to help the reader review the chapter contents.

## AUTHOR'S NOTES

This feature includes simple explanations, stories, or examples of complex topics. These are included to help students understand difficult concepts.

## TERMS TO KNOW LIST

A list of new terms appears next to the Summary.



FIGURE 5-14 Low-maintenance battery grid with vertical grid bars intersecting at an angle.

- Low reserve capacity.
- Faster discharge by parasitic loads.
- Shorter life expectancy.

### HYBRID BATTERIES

**AUTHOR'S NOTE:** The following discussion on hybrid batteries refers to a battery type and not to the batteries that are used in hybrid electric vehicles (HEVs).

The **hybrid battery** combines the advantages of the low-maintenance and maintenance-free battery. The hybrid battery can withstand six deep cycles and still retain 100% of its original reserve capacity. The grid construction of the hybrid battery consists of approximately 2.75% antimony alloy on the positive plates and a calcium alloy on the negative plates. This allows the battery to withstand deep cycling while retaining reserve capacity for improved cranking performance. Also, the use of antimony alloys reduces grid growth and corrosion. The lead calcium has less gassing than conventional batteries.

Grid construction differs from other batteries in that the plates have a lug located near the center of the grid. In addition, the vertical and horizontal grid bars are arranged in a radial pattern (Figure 5-15). By locating the lug near the center of the grid and using the **radial grid**



**A BIT OF HISTORY**  
Check that introduced the storage battery as standard equipment in 1900.

**Radial means** branching out from a central center.

### SUMMARY

- Methods that are being used and developed for the electrical architecture of the 42-volt system include a single 42-volt system or a dual-voltage system.
- The dual voltage system may use a dual generator system where one generator operates at 42 volts, while the other operates at 14 volts.
- A dual stator, dual voltage system produces dual voltage from a single alternator that has two output voltages.
- A DC/DC converter is configured to provide a 14 V output from the 42-volt input. The 14 V output can be used to supply electrical energy to those components that do not require 42 volts.
- Cell construction of the NiCad battery is the cathode (positive) electrode is made of fiber mesh covered with nickel hydroxide, while the anode (negative) electrode is a fiber mesh that is covered with cadmium. The electrolyte is aqueous potassium hydroxide (KOH).
- During discharge, ions travel from the anode, through the KOH, and on to the cathode. During charging, the opposite occurs.
- The cathode electrode of the NiMH battery is a fiber mesh that contains nickel hydroxide. The anode electrode is made of hydrogen-absorbing metal alloys. The cathode and anode electrodes are separated by a sheet of fine fibers saturated with an aqueous and alkaline electrolyte KOH.
- Under load, the cell discharges and the hydrogen moves from the anode to the cathode electrode. Since the electrolyte only supports the ion movement from one electrode to the other, it has no active role in the chemical reaction, and the electrolyte level does not change.
- A 300-volt NiMH battery is constructed of 240 cells that produce 1.2 volts each. The cells are made into a module, with each module having 6 cells. The modules are connected in series to create the total voltage.
- A service disconnect in the HV battery is used to disable the HV system if repairs or service to any part of the system is required. This service connector provides two functions that are used to separate the HV battery pack into two separate batteries, with approximately 150 volts each.
- Contactors are heavy-duty relays that are connected to the positive and negative sides of the HV battery.
- The contactors are normally open and require a 12-volt supply to keep them closed.
- Ultra-capacitors are capacitors constructed to have a large electrode surface area and a very small distance between the electrodes.
- Ultra-capacitors are used in many present day hybrid vehicles and in some experimental fuel cell electric vehicles because of their ability to quickly discharge high voltages and then be quickly recharged.
- Hybrids that use regenerative braking, a starter/generator with the stop/start feature, and the 42-volt system will use ultra-capacitors to restart the engine.
- The three most common types of battery terminals are:
  - Post or top terminals: Used on most automotive batteries. The positive post will be larger than the negative post to prevent connecting the battery in reverse polarity.
  - Side terminals: Positioned in the side of the container near the top. These terminals are threaded and require a special bolt to connect the cables. Polarity identification is by positive and negative symbols.
  - L terminals: Used on specialty batteries and some imports.
- The most common methods of battery rating are cold cranking, cranking amps, reserve capacity, and ampere-hour.

### TERMS TO KNOW

Activated glass mat (AGM) battery  
Ampere-hour rating  
Battery cables  
Car alternator  
Cold cranking rating  
Contactors  
Cranking amps (CA)  
Deep cycling  
Electrochemical  
Electrolyte  
Energy density (watt-hour)  
Gassing  
Grid  
Grid growth  
Maintenance-free battery  
Hybrid batteries  
Hydroxide  
Integrated starter generator (ISG)  
Maintenance-free battery  
Minicell capacitors  
Memory effect  
Radial  
Radial grid  
Recombination batteries  
Regenerative braking  
Reserve capacity  
Reserve capacity rating  
Specific gravity  
Tension  
Ultra-capacitors  
Vibration Regulated Lead-Acid (VRLA) batteries

130

### SUMMARY

#### TERMS TO KNOW

(continued)

Starting magnetic field  
Sentry key  
Shunt  
Sip  
Start/clutch solenoid switch  
Starter drive  
Static neutral point  
Synchronous motor  
Synchronous speed

#### REVIEW QUESTIONS

##### Short-Answer Essays

- What is the purpose of the starting system?
- List and describe the purpose of the major components of the starting system.
- Explain the principle of operation of the DC motor.
- Describe the types of magnetic switches used in starting systems.
- Describe the operation of the overrunning clutch drive.
- Describe the differences between the positive-engagement and solenoid shift starter.
- Explain the operating principles of the permanent magnet starter.
- Describe the purpose and operation of the armature.
- Describe the purpose and operation of the field coil.
- Describe how the rotor turns in a three-phase AC motor.

##### Fill in the Blanks

- DC motors use the interaction of magnetic fields to convert the \_\_\_\_\_ energy; \_\_\_\_\_ energy into \_\_\_\_\_ energy.
- The \_\_\_\_\_ is the moveable component of the motor, which consists of a conductor wound around a \_\_\_\_\_ iron core and is used to create a \_\_\_\_\_ field.

10-4

- In order to start the synchronous motor, the rotor contains a squirrel-type winding to act as an induction motor.
- An induction motor rotor windings can be in the form of a squirrel cage or constructed by winding three separate coils on the rotor 120° apart.
- The ISG can also convert kinetic energy to storable electric energy. When the vehicle is traveling downhill and there is zero load on the engine, the wheels can transfer energy through the transmission and engine to the ISG. The ISG then sends this energy to the battery for storage and use by the electrical components of the vehicle.
- The belt alternator starter (BAS) is about the same size as a conventional generator and is mounted in the same way.
- The ISG is a three-phase AC motor. At low vehicle speeds, the ISG provides power and torque to the vehicle. It also supports the engine, when the driver demands more power.
- Both the BAS and the ISG use the same principle to start the engine. Current flows through the stator windings it generates magnetic fields in the rotor. This will cause the rotor to turn, thus turning the crankshaft and starting the engine.

##### 3. Pole shoes are made of high-magnetic

direct the \_\_\_\_\_ material to help concentrate and \_\_\_\_\_ in the field assembly.

- The starter motor electrical connection that permits all of the current that passes through the field coils to also pass through the armature is called the \_\_\_\_\_ motor.

\_\_\_\_\_ is voltage produced in the starter motor itself. This current acts against the supply voltage from the battery.

- A starter motor that uses the characteristics of a series motor and a shunt motor is called a \_\_\_\_\_ motor.
- The \_\_\_\_\_ is the part of the starter motor that engages the armature to the engine flywheel ring gear.

8. The \_\_\_\_\_ is a roller-type clutch that transmits torque in one direction only and freewheels in the other direction.

- The two circuits of the starting system are called the \_\_\_\_\_ circuit and the \_\_\_\_\_ circuit.

10. There are two basic types of magnetic switches used in starter systems: the \_\_\_\_\_ and the \_\_\_\_\_.

## REVIEW QUESTIONS

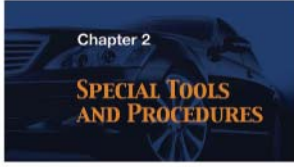
Short answer essay, fill-in-the-blank, and multiple-choice questions are found at the end of each chapter. These questions are designed to accurately assess the student's competence in the stated objectives at the beginning of the chapter.

To stress the importance of safe work habits, the Shop Manual dedicates one full chapter to safety. Other important features of this manual include:

## PERFORMANCE-BASED OBJECTIVES

These objectives define the contents of the chapter and define what the student should have learned upon completion of the chapter. These objectives also correspond with the list of required tasks for ASE certification. *Each ASE task is addressed.*

Although this textbook is not designed to simply prepare someone for the certification exams, it is organized around the ASE task list. These tasks are defined generically when the procedure is commonly followed and specifically when the procedure is unique for specific vehicle models. Imported- and domestic-model automobiles and light trucks are included in the procedures.



**Chapter 2**  
**SPECIAL TOOLS AND PROCEDURES**

**BASIC TOOLS**  
Basic mechanic's tool set

**UPON COMPLETION AND REVIEW OF THIS CHAPTER, YOU SHOULD BE ABLE TO:**

- Explain the proper use of jumper wires.
- Explain the proper use of a test light.
- Explain the proper use of a logic probe.
- Explain the proper use of analog volt/amp/ohmmeters.
- Explain the proper use of digital volt/amp/ohmmeters.
- Describe when to use the different types of multimeters.
- Explain the proper use of a digital storage oscilloscope.
- Use Ohm's law to determine electrical values in different types of circuits.
- Locate service information.
- Explain the concepts of working as an electrical systems technician.

**INTRODUCTION**  
This chapter covers some of the typical shop procedures that the electrical systems technician may encounter. This includes proper troubleshooting procedures, the use of special test equipment, the use of service information, and workplace practices.  
To be able to properly diagnose electrical components and circuits, you must be able to use many different types of electrical test equipment. In this chapter, you will learn when and how to use the most common types of test equipment. You will also learn which test instrument is best to use to identify the cause of the various types of electrical problems.  
Electrical current is a term used to describe the movement or flow of electricity. The greater number of electrons flowing past a given point in a given amount of time, the more current the circuit has. This current, like the flow of water or any other substance, can be

**Classroom Manual**  
Chapter 2, page 25

## BASIC TOOLS LIST

Each chapter begins with a list of the basic tools needed to perform the tasks included in the chapter.

## SPECIAL TOOLS LIST

Whenever a special tool is required to complete a task, it is listed in the margin next to the procedure.

## PHOTO SEQUENCES

Many procedures are illustrated in detailed Photo Sequences. These detailed photographs show the students what to expect when they perform particular procedures. They also can provide the student a familiarity with a system or type of equipment, which the school may not have.

**PHOTO SEQUENCE 4**  
**VOLTAGE DROP TEST TO LOCATE HIGH CIRCUIT RESISTANCE**



**P4-1** Tools required to test for excessive resistance in a starting circuit are fender covers, a DVOM, and a remote starter switch.

**P4-2** Connect the positive lead of the meter to the positive battery post. If possible, do not connect the lead to the cable clamp.

**P4-3** Connect the negative lead of the meter to the main battery terminal on the starter motor.

**P4-4** To conduct a voltage drop test, current must flow through the circuit. In this test, the ignition system is disabled and the engine is cranked using a remote starter switch.

**P4-5** With the engine cranking, read the voltmeter. The reading is the amount of voltage drop.

**P4-6** If the reading is out of specifications, test at the next connection toward the battery. In this instance, the next test point is the starter side of the relay.

**P4-7** Crank the engine and touch the negative test lead to the starter side of the relay. Observe the voltmeter while the engine is cranking.

**P4-8** Test in the same manner on the battery side of the relay. This is the voltage drop across the positive circuit from the battery to the relay.

**102**

**No Operation in One Speed Only**  
Problems that cause the system to not operate in only one switch position are usually electrical. Use the service manual's wiring schematic to determine proper operation. For example, use the three-speed wiper system schematic illustrated (Figure 14-7) to determine the cause of a motor that does not operate in the MEDIUM speed position only. The problem is that the 7-ohm resistor is open. The problem could not be the shunt field in the motor because LOW and HIGH speeds operate, nor could it be in the wiring to the motor because this is shared by all speeds.  
An opened resistor can be verified by using a voltmeter to measure voltage at the terminal leading to the shunt field. If it drops to 0 volts in the MEDIUM position, the switch must be replaced. By proper use of the wiring schematic and by understanding the correct operation of the system, you are able to diagnose this problem without having to use any test equipment. The voltmeter is used only to verify your conclusions.  
In two-speed systems, the motor operating in only one speed position can be caused by several different faults. It will require the use of wiring schematics and test equipment to locate. Use (Figure 14-8) to step through a common test sequence to locate the reason why the motor does not operate in the HIGH position.  
Turn the ignition switch to the ACC position if the wipers will operate in this position. If not, place the ignition switch in the RUN position. Place the wiper switch in the HIGH position. Use a voltmeter to test for voltage at the high-speed connector of the motor. If voltage is present at this point, the high-speed brush is worn or the wire from the terminal to the brush is open. Most shops do not rebuild the wiper motor; replacement is usually the preferred service. If there is no voltage present at the high-speed connector, check for voltage at connector terminal H for the switch. If voltage is present at this point, the fault is in the circuit from the switch to the motor. If there is no voltage at this point, replace the switch.  
To test for no LOW speed operation only, use the same procedure to test the

**Classroom Manual**  
Chapter 14, page 203

**SPECIAL TOOLS**  
Voltmeter  
Fender covers

**CAUTION:**  
Do not leave the ignition switch in the RUN position without the engine running for extended periods of time. This may result in damage to the ignition system components.

The instance is used as an example of troubleshooting the wiper system. Be sure to use the correct techniques for the vehicle you are working on.

**667**

## MARGINAL NOTES

These notes add “nice-to-know” information to the discussion. They may include examples or exceptions, or may give the common trade jargon for a component.



## SERVICE TIPS

Whenever a short-cut or special procedure is appropriate, it is described in the text. These tips are generally those things commonly done by experienced technicians.

- Before touching any of the high-voltage system wires or components, wear insulating gloves, make sure the power switch is off, and disconnect the auxiliary battery.
- Turn the power switch to the OFF position prior to performing a resistance check.
- Turn the power switch to the OFF position prior to disconnecting or reconnecting any connectors or components.
- Isolate with insulation tape any high-voltage wires that have been removed.
- Properly torque the high-voltage terminals.

### Insulating Glove Integrity Test

The insulating gloves that the technician wears for protection while servicing the high-voltage system must be tested for integrity before use. If there is a leak in the gloves, high-voltage electricity can travel through the hole to the technician's body. To test a glove, blow air into it and then fold it at the base to seal the air inside. Slowly roll the base of the glove toward the fingers. If the glove holds pressure, its insulating properties are intact. If any leaks are detected, discard the glove.

### HIGH-VOLTAGE SERVICE PLUG

The HEV is equipped with a high-voltage service plug that disconnects the HV battery from the system. Usually, this plug is located near the battery (Figure 16-21). Prior to disconnecting the high-voltage service plug, the vehicle must be turned off and the negative terminal of the auxiliary battery must be disconnected. Once the high-voltage service plug is removed, the high-voltage circuit is shut off at the intermediate position of the HV battery.

The high-voltage service plug assembly contains a safety interlock reed switch. The reed switch is opened when the clip on the high-voltage service plug is lifted. The open reed switch turns off power to the service main relay (SMR). The main fuse for the high-voltage circuit is

#### SPECIAL TOOLS

DMM capable of reading 400 VDC  
Insulating gloves  
Insulating tape



#### SERVICE TIP:

DTCs will be erased once the batteries are disconnected. Prior to disconnecting the system, be sure to check and record any DTCs.



#### CAUTION:

Once the high-voltage service plug is removed, DO NOT operate the power switch. Doing so may damage the hybrid vehicle control ECU.

## CAUTIONS AND WARNINGS

Throughout the text, warnings are given to alert the reader to potentially hazardous materials or unsafe conditions. Cautions are given to advise the student of things that can go wrong if instructions are not followed or if a nonacceptable part or tool is used.

## CROSS-REFERENCES TO THE CLASSROOM MANUAL

Reference to the appropriate page in the Classroom Manual is given whenever necessary. Although the chapters of the two manuals are synchronized, material covered in other chapters of the Classroom Manual may be fundamental to the topic discussed in the Shop Manual.

### Three-minute Charge Test

If a conventional battery fails the load test, it is not always the fault of the battery. It is possible that the battery has not been receiving an adequate charge from the charging system. The 3-minute charge test determines the battery's ability to accept a charge, and for sulfation. Sulfation is a chemical action within the battery that interferes with the ability of the cells to deliver current and accept a charge (Figure 5-20). A battery must have failed the load test to get accurate results from a 3-minute charge test.

#### To conduct the 3-minute test:

1. Remove the ground cable. The battery must be disconnected from the vehicle's electrical system since the high voltage that is possible during this test can damage the computers.
2. Connect a battery charger to the battery, observing polarity.
3. Connect a voltmeter across the battery terminals, observing polarity.
4. Turn on the battery charger to 40 amperes (20–25 for maintenance-free batteries).
5. Maintain this rate of charge for 3 minutes.
6. Check the voltage reading at 3 minutes. If fewer than 15.5 volts, the battery is not sulfated. If the voltmeter reading is above 15.5 volts, the battery is sulfated or there is a poor internal connection.
7. If the battery passes the 3-minute test, slowly recharge the battery and do the load test again.
8. If the battery passes the load test this time, test the charging system.

**WARNING:** Some battery manufacturers, such as Delco, do NOT recommend the 3-minute charge test.

**CUSTOMER CARE:** One of the best things you can do for your customers is to assist them in choosing the correct battery. Battery selection needs to be based on the make of the vehicle, electrical options on the vehicle, driving habits, and climatic conditions. The largest current capacity rating that can be achieved in a given battery group may benefit some customers but may be a waste of money for others.

Classroom Manual  
Chapter 5, page 113



#### SPECIAL TOOLS

Battery charger  
Voltmeter  
Safety glasses  
Fender covers

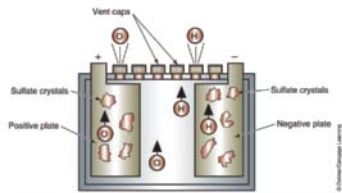


FIGURE 5-20 A sulfated battery is the result of sulfate crystals that penetrate the plates. The crystals become insoluble and will not allow the battery cell to deliver current nor accept a charge.

## JOB SHEET

4

Name \_\_\_\_\_ Date \_\_\_\_\_

### USING OHM'S LAW TO CALCULATE ELECTRICAL PROPERTIES

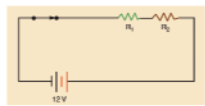
Using Ohm's law, solve the following problems:

#### Exercise 1—Series Circuit

Refer to the circuit presented below.

Use Ohm's law to calculate the following values, when  $R_1 = 2$  ohms and  $R_2 = 4$  ohms:

Total circuit resistance = \_\_\_\_\_ ohms  
Circuit current = \_\_\_\_\_ amps  
Current through  $R_1$  = \_\_\_\_\_ amps  
Current through  $R_2$  = \_\_\_\_\_ amps  
Voltage drop across  $R_1$  = \_\_\_\_\_ volts  
Voltage drop across  $R_2$  = \_\_\_\_\_ volts



If the resistance of  $R_1$  increases to 8 ohms, what are the new values?

Total circuit resistance = \_\_\_\_\_ ohms  
Circuit current = \_\_\_\_\_ amps  
Current through  $R_1$  = \_\_\_\_\_ amps  
Current through  $R_2$  = \_\_\_\_\_ amps  
Voltage drop across  $R_1$  = \_\_\_\_\_ volts  
Voltage drop across  $R_2$  = \_\_\_\_\_ volts

#### Exercise 2—Series Circuit

Refer to the circuit provided below.

Use Ohm's law to calculate the following values, when  $R_1 = 3$  ohms and  $R_2 = 6$  ohms:

Total circuit resistance = \_\_\_\_\_ ohms  
Circuit current = \_\_\_\_\_ amps  
Current through  $R_1$  = \_\_\_\_\_ amps

79

## CUSTOMER CARE

This feature highlights those little things a technician can do or say to enhance customer relations.

## JOB SHEETS

Located at the end of each chapter, the Job Sheets provide a format for students to perform procedures covered in the chapter. A reference to the ASE task addressed by the procedure is referenced on the Job Sheet.

## CASE STUDIES

Case Studies concentrate on the ability to properly diagnose the systems. Beginning with Chapter 3, each chapter ends with a case study in which a vehicle has a problem, and the logic used by a technician to solve the problem is explained.

## ASE-STYLE REVIEW QUESTIONS

Each chapter contains ASE-style review questions that reflect the performance-based objectives listed at the beginning of the chapter. These questions can be used to review the chapter as well as to prepare for the ASE certification exam.

### CASE STUDY

An owner of a 2005 Prius has brought his vehicle into the shop. He claims that the master warning light comes on every once in a while but goes out after a couple of starts. The technician retrieves the DTCs from the HV ECU and finds a "Shift before ready" code. Upon investigation of the information code, the technician also refers to history data. Here it is determined

that the cause of the fault was that the customer was not waiting for the ready light to stop flashing before placing the transmission into drive. The warning light would go out after three starts if the same condition did not reoccur. The technician took the time to go over the proper startup sequence with the vehicle owner so future problems could be avoided.

### TERMS TO KNOW (continued)

History data  
Information codes  
Inverter  
System main relay (SMR)

### ASE-STYLE REVIEW QUESTIONS

- All of the following statements concerning hybrid high-voltage system safety is true EXCEPT:
  - Disconnect the motor generators prior to turning the ignition off.
  - Disconnect the negative (-) terminal of the auxiliary battery before removing the service plug.
  - Do not attempt to test or service the system for five minutes after the high-voltage service plug is removed.
  - Turn the power switch to the OFF position prior to performing a resistance check.
- Technician A says HEV batteries can provide over 270 volts.  
Technician B says the HEV high-voltage from the MG1 and MG2 to the inverter/converter can be more than 500 volts.  
Who is correct?
  - A only
  - B only
  - Both A and B
  - Neither A nor B
- When working on the high-voltage system, which of the following should be done?
  - Always place the high-voltage service plug where someone will not accidentally reinstall it.
  - Before servicing, use a voltmeter set on 400 VDC to determine if the high-voltage system voltage is at 0 volts.
  - Test the integrity of the insulating gloves prior to use.
  - All of the above.
- Technician A says the main system relay should be removed before disconnecting the service plug.  
Technician B says the high-voltage components are usually identified with a warning label.  
Who is correct?
  - A only
  - B only
  - Both A and B
  - Neither A nor B
- To test the integrity of the insulating gloves:
  - Fill the gloves with water to see if there is a leak.
  - Fill the gloves with air and submerge in water to see if air bubbles arise from any leaks.
  - Shine a flashlight into the glove and see if light escapes.
  - None of the above.
- The high-voltage service plug:
  - Disconnects the inverter/converter from the motor generators.
  - Disconnects the auxiliary battery from the HV battery.
  - Disconnects the HV battery from the system.
  - Provides a connection for the battery charger.
- Technician A says once the service plug is disconnected, there is no high voltage in the vehicle systems.  
Technician B says prior to disconnecting the high voltage service plug, the vehicle must be turned off and the negative terminal of the auxiliary battery must be disconnected.  
Who is correct?
  - A only
  - B only
  - Both A and B
  - Neither A nor B
- Technician A says the high-voltage electronic control unit (HV ECU) can shut down the high-voltage system if a fault is detected.  
Technician B says if the auxiliary battery voltage goes low, the HV ECU will direct regenerative braking energy to the auxiliary battery.  
Who is correct?
  - A only
  - B only
  - Both A and B
  - Neither A nor B

883

## TERMS TO KNOW LIST

Terms in this list can be found in the Glossary at the end of the manual.

### ASE CHALLENGE QUESTIONS

- A customer states that the "Pass Air bag off" light comes on whenever they lay their briefcase on the front passenger seat.  
Technician A says the OCS is too sensitive and needs to be validated.  
Technician B says this is normal since the weight of the briefcase is matching the weight of a small child.  
Who is correct?
  - A only
  - B only
  - Both A and B
  - Neither A nor B
- The customer is concerned about the "Pass Air Bag Off" light not illuminating when their eight-year-old child sits on the seat. The vehicle is equipped with a bladder-type system.  
Technician A says this is normal operation.  
Technician B says a DTC will set for this condition.  
Who is correct?
  - A only
  - B only
  - Both A and B
  - Neither A nor B
- A customer states that while driving the vehicle, the air bag warning lamp illuminates intermittently.  
Technician A says this can be caused by a loose connection to one of the system's sensors.  
Technician B says this may indicate a defect that will set a trouble code.  
Who is correct?
  - A only
  - B only
  - Both A and B
  - Neither A nor B
- Passenger-side air bag deactivation is being discussed.  
Technician A says if the vehicle is not equipped with a factory installed ON/OFF switch, disconnect the connector to the air bag module and remove the air bag warning lamp.  
Technician B says the vehicle owner must provide a letter of approval from the NHTSA before a deactivation kit can be installed.  
Who is correct?
  - A only
  - B only
  - Both A and B
  - Neither A nor B
- Side-impact air bags are being discussed.  
Technician A says most systems have a control module or sensor located in the B pillar.  
Technician B says the side air bags only deploy when the front air bags deploy.  
Who is correct?
  - A only
  - B only
  - Both A and B
  - Neither A nor B

880

## ASE CHALLENGE QUESTIONS

Each technical chapter ends with five ASE challenge questions. These are not more review questions; rather, they test the students' ability to apply general knowledge to the contents of the chapter.

## SUPPLEMENTS

---

### INSTRUCTOR RESOURCES

The Instructor Resources DVD is a robust ancillary that contains all preparation tools to meet any instructor's classroom needs. It includes chapter outlines in PowerPoint with images, video clips, and animations that coincide with each chapter's content coverage, chapter tests in ExamView with hundreds of test questions, a searchable Image Library with all photos and illustrations from the text, theory-based Worksheets in Word that provide homework or in-class assignments, the Job Sheets from the Shop Manual in Word, a NATEF correlation chart, and an Instructor's Guide in electronic format.

### WEBTUTOR ADVANTAGE

Newly available for this title and to the Today's Technician™ Series is the *WebTutor Advantage*, for Blackboard and Angel online course management systems. The *WebTutor for Today's Technician: Automotive Electricity & Electronics, 5e* includes PowerPoint presentations with images and animations, end-of-chapter review questions, pre-tests and post-tests, worksheets, discussion springboard topics, Job Sheets, and more. The *WebTutor* is designed to enhance the classroom and shop experience, engage students, and help them prepare for ASE certification exams.

## REVIEWERS

---

The author and publisher would like to extend a special thanks to the following instructors for their contributions to this text:

**Timothy Belt**

University of Northwestern Ohio  
Lima, OH

**Jason Daniels**

University of Northwestern Ohio  
Lima, OH

**Kevin Fletcher**

Asheville-Buncombe Technical Community  
College  
Asheville, NC

**Jose Gonzalez**

Automotive Training Center  
Exton, PA

**Jack D. Larmor**

Baker College  
Flint, MI

**David Tapley**

University of Northwestern Ohio  
Lima, OH

**Omar Trinidad**

S. Illinois University Carbondale  
Carbondale, IL

**David Young**

University of Northwestern Ohio  
Lima, OH

# Chapter 1

## INTRODUCTION TO AUTOMOTIVE ELECTRICAL AND ELECTRONIC SYSTEMS

### UPON COMPLETION AND REVIEW OF THIS CHAPTER, YOU SHOULD BE ABLE TO UNDERSTAND AND DESCRIBE:

- The importance of learning automotive electrical systems.
- The role of electrical systems in today's vehicles.
- The interaction of the electrical systems.
- The purpose of the starting system.
- The purpose of the charging system.
- The role of the computer in today's vehicles.
- The purpose of vehicle communication networks.
- The purpose of various electronic accessory systems.
- The purpose of passive restraint systems.
- The purpose of alternate propulsion systems.

### INTRODUCTION

You are probably reading this book for one of two reasons. Either you are preparing yourself to enter into the field of automotive service or you are expanding your skills to include automotive electrical systems. In either case, congratulations on selecting one of the most fast-paced segments of the automotive industry. Working with the electrical systems can be challenging, yet very rewarding; however, it can also be very frustrating at times.

For many people, learning electrical systems can be a struggle. It is my hope that I am able to present the material to you in such a manner that you will not only understand electrical systems but will excel at it. There are many ways the theory of electricity can be explained, and many metaphors can be used. Some compare electricity to a water flow, while others explain it in a purely scientific fashion. Everyone learns differently. I am presenting electrical theory in a manner that I hope will be clear and concise. If you do not fully comprehend a concept, then it is important to discuss it with your instructor. Your instructor may be able to use a slightly different method of instruction to help you to completely understand the concept. Electricity is somewhat abstract; so if you do have questions, be sure to ask your instructor.

### WHY BECOME AN ELECTRICAL SYSTEM TECHNICIAN?

In the past it was possible for technicians to work their entire careers and be able to almost completely avoid the vehicle's electrical systems. They would specialize in engines, steering/suspension, or brakes. Today there is not a system on the vehicle that is immune to the role



of electrical circuits. Engine controls, electronic suspension systems, and antilock brakes are common on today's vehicles. Even electrical systems that were once thought of as being simple have evolved to computer controls. Headlights are now pulse-width modulated using high-side drivers and will automatically brighten and dim based on the light intensity of oncoming traffic. Today's vehicles are equipped with twenty or more computers, laser-guided cruise control, sonar park assist, infrared climate control, fiber optics, and radio frequency transponders and decoders. Simple systems have become more computer reliant. For example, the horn circuit on the 2008 Chrysler 300C involves three separate control modules to function. Even the tires have computers involved, with the addition of tire pressure monitoring systems!

Today's technician must possess a full and complete electrical background to be able to succeed. The future will provide great opportunities for those technicians who have prepared themselves properly.



## A BIT OF HISTORY

Karl Benz of Mannheim, Germany, patented the world's first automobile on January 29, 1886. The vehicle was a three-wheeled automobile called the Benz Motorwagen. That same year Gottlieb Daimler built a four-wheeled vehicle. It was powered by a 1.5-horsepower engine that produced 50% more power than that of the Benz Motorwagen. The first automobile to be produced for sale in the United States was the 1896 Duryea.

## THE ROLE OF ELECTRICITY IN THE AUTOMOBILE

In the past, electrical systems were basically stand-alone. For example, the ignition system was only responsible for supplying the voltage needed to fire the spark plugs. Ignition timing was controlled by vacuum and mechanical advance systems. Today there are very few electrical systems that are still independent.

Today, most manufactures **network** their electrical systems together through computers. This means that information gathered by one system can be used by another. The result may be that a faulty component may cause several symptoms. Consider the following example. The wiper system can interact with the headlight system to turn on the headlights whenever the wipers are turned on. The wipers can interact with the vehicle speed sensor to provide for speed-sensitive wiper operation. The speed sensor may provide information to the antilock brake module. The antilock brake module can then share this information with the transmission control module, and the instrument cluster can receive vehicle speed information to operate the speedometer. If the vehicle speed sensor should fail, this could result in no antilock brake operation and a warning light turned on in the dash. But it could also result in the speedometer not functioning, the transmission not shifting, and the wipers not operating properly.

## INTRODUCTION TO THE ELECTRICAL SYSTEMS

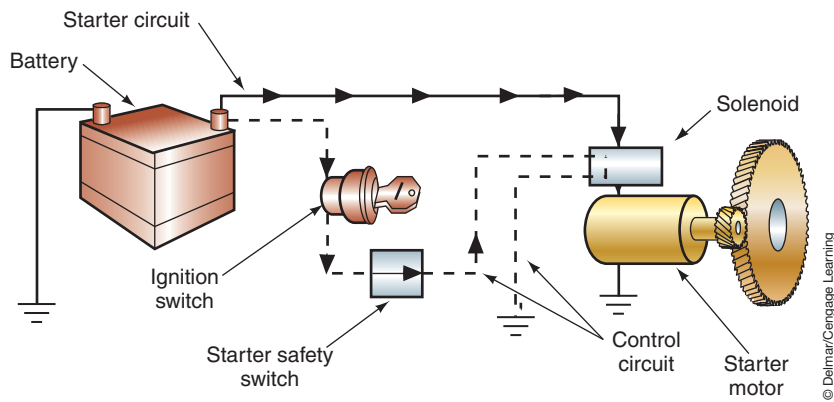
The purpose of this section is to acquaint you with the electrical systems that will be covered in this book. We will define the purpose of these systems.

**AUTHOR'S NOTE:** The discussion of the systems in this section of the chapter provides you with an understanding of their *main* purpose. Some systems have secondary functions. All of these will be discussed in detail in later chapters.

## The Starting System

The **starting system** is a combination of mechanical and electrical parts that work together to start the engine. The starting system is designed to change the electrical energy, which is being supplied by the battery, into mechanical energy. For this conversion to be accomplished, a starter or cranking motor is used. The basic starting system includes the following components (Figure 1-1):

1. Battery.
2. Cable and wires.



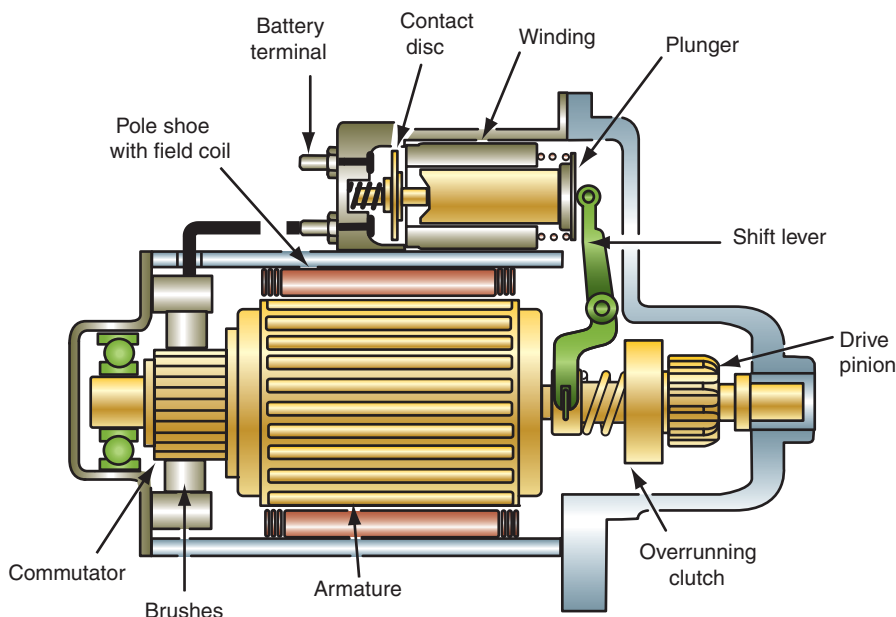
**FIGURE 1-1** Major components of the starting system.

© Delmar/Cengage Learning

3. Ignition switch.
4. Starter solenoid or relay.
5. Starter motor.
6. Starter drive and flywheel ring gear.
7. Starting safety switch.

The starter motor (Figure 1-2) requires large amounts of current (up to 400 amperes) to generate the torque needed to turn the engine. The conductors used to carry this amount of current (battery cables) must be large enough to handle the current with very little voltage drop. It would be impractical to place a conductor of this size into the wiring harness to the ignition switch. To provide control of the high current, all starting systems contain some type of magnetic switch. There are two basic types of magnetic switches used: the solenoid and the relay.

The **ignition switch** is the power distribution point for most of the vehicle's primary electrical systems. The ignition switch is spring loaded in the start position. This momentary contact automatically moves the contacts to the RUN position when the driver releases the key. All other ignition switch positions are detent positions.



**FIGURE 1-2** Starter motor.

© Delmar/Cengage Learning



## A BIT OF HISTORY

The Model T was called the first “people’s car.” Prior to its introduction by the Ford Motor Company in 1908, the automobile could only be purchased by the wealthy. It was Henry Ford’s desire to build a car for the masses. Although Henry Ford had no professional engineering education, he did possess a natural inclination toward mechanics. To keep production costs down, he used assembly-line production to manufacture the Model T. Henry Ford also introduced the moving conveyor belt into the assembly process, further accelerating production. The Model T was nicknamed Tin Lizzie because its body was made from lightweight sheet steel. The production of the Model T continued till 1927, with more than 16.5 million vehicles being produced. The electrical system was very simple and originally consisted of

The **neutral safety switch** is used on vehicles that are equipped with automatic transmissions. It opens the starter control circuit when the transmission shift selector is in any position except PARK or NEUTRAL. Vehicles that are equipped with automatic transmissions require a means of preventing the engine from starting while the transmission is in gear. Without this feature, the vehicle would lunge forward or backward once it was started, causing personal or property damage. The normally open neutral safety switch is connected in series into the starting system control circuit and is usually operated by the shift lever (Figure 1-3). When in the PARK or NEUTRAL position, the switch is closed, allowing current to flow to the starter circuit. If the transmission is in a gear position, the switch is opened and current cannot flow to the starter circuit.

Many vehicles that are equipped with manual transmissions use a similar type of safety switch. The start/clutch interlock switch is usually operated by movement of the clutch pedal (Figure 1-4).

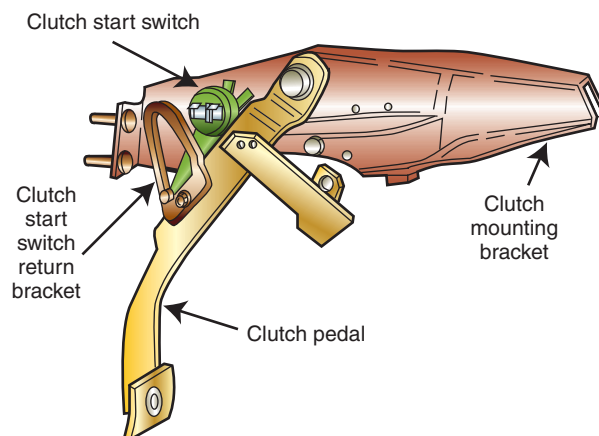
## The Charging System

The automotive storage battery is not capable of supplying the demands of the electrical systems for an extended period of time. Every vehicle must be equipped with a means of replacing the energy that is being drawn from the battery. A **charging system** is used to restore to the battery the electrical power that was used during engine starting. In addition, the



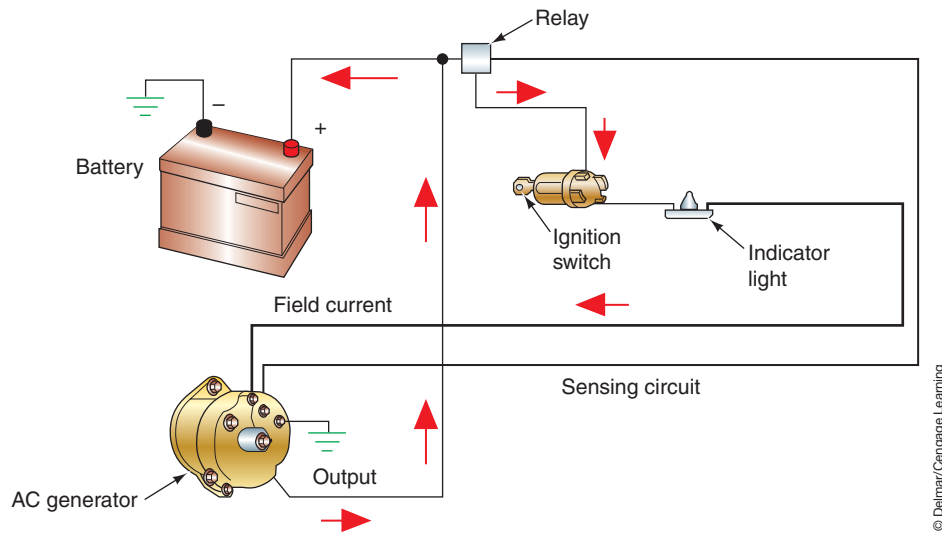
© Delmar/Cengage Learning

**FIGURE 1-3** The neutral safety switch is usually attached to the transmission.



© Delmar/Cengage Learning

**FIGURE 1-4** Most vehicles with a manual transmission use a clutch start switch.



**FIGURE 1-5** Components of the charging system.



## A BIT OF HISTORY

(continued)

a flywheel magneto that produced low-voltage alternating current. This AC voltage was used to power a trembler coil that created a high-voltage current for use by the ignition system. The ignition pulse was passed to the timer (distributor) and directed to the proper cylinder. Ignition timing was adjusted manually via the spark advance lever that was mounted on the steering column. Moving the lever rotated the timer to advance or retard the ignition timing. Since the magneto may not produce sufficient current when starting the engine with the hand crank, a battery could be used to provide the required starting current. When electric headlights were introduced in 1915, the magneto was used to supply power for the lights and the horn.

charging system must be able to react quickly to high load demands required of the electrical system. It is the vehicle's charging system that generates the current to operate all of the electrical accessories while the engine is running.

The purpose of the charging system is to convert the mechanical energy of the engine into electrical energy to recharge the battery and run the electrical accessories. When the engine is first started, the battery supplies all the current required by the starting and ignition systems.

As illustrated in Figure 1-5, the entire charging system consists of the following components:

1. Battery.
2. AC generator or DC generator.
3. Drive belt.
4. Voltage regulator.
5. Charge indicator (lamp or gauge).
6. Ignition switch.
7. Cables and wiring harness.
8. Starter relay (some systems).
9. Fusible link (some systems).

All charging systems use the principle of electromagnetic induction to generate the electrical power. A **voltage regulator** controls the output voltage of the AC generator, based on charging system demands, by controlling field current. The battery, and the rest of the electrical system, must be protected from excessive voltages. To prevent early battery and electrical system failure, regulation of the charging system is very important. Also, the charging system must supply enough current to run the vehicle's electrical accessories when the engine is running.

## The Lighting System

The **lighting system** consists of all of the lights used on the vehicle (Figure 1-6). This includes headlights, front and rear park lights, front and rear turn signals, side marker lights, daytime running lights, cornering lights, brake lights, back-up lights, instrument cluster backlighting, and interior lighting.

The lighting system of today's vehicles can consist of more than 50 light bulbs and hundreds of feet of wiring. Incorporated within these circuits are circuit protectors, relays,



**FIGURE 1-6** Automotive lighting system.

switches, lamps, and connectors. In addition, more sophisticated lighting systems use computers and sensors. Since the lighting circuits are largely regulated by federal laws, the systems are similar among the various manufacturers. However, there are variations that exist in these circuits.

With the addition of solid-state circuitry in the automobile, manufacturers have been able to incorporate several different lighting circuits or modify the existing ones. Some of the refinements that were made to the lighting system include automatic headlight washers, automatic headlight dimming, automatic on/off with timed-delay headlights, and illuminated entry systems. Some of these systems use sophisticated body computer-controlled circuitry and fiber optics.

Some manufacturers have included such basic circuits as turn signals into their body computer to provide for pulse-width dimming in place of a flasher unit. The body computer can also be used to control instrument panel lighting based on inputs that include if the side marker lights are on or off. By using the body computer to control many of the lighting circuits, the amount of wiring has been reduced. In addition, the use of computer control of these systems has provided a means of self-diagnosis in some applications.

Today, high-density discharge (HID) headlamps are becoming an increasingly popular option on many vehicles. These headlights provide improved lighting over conventional headlamps.

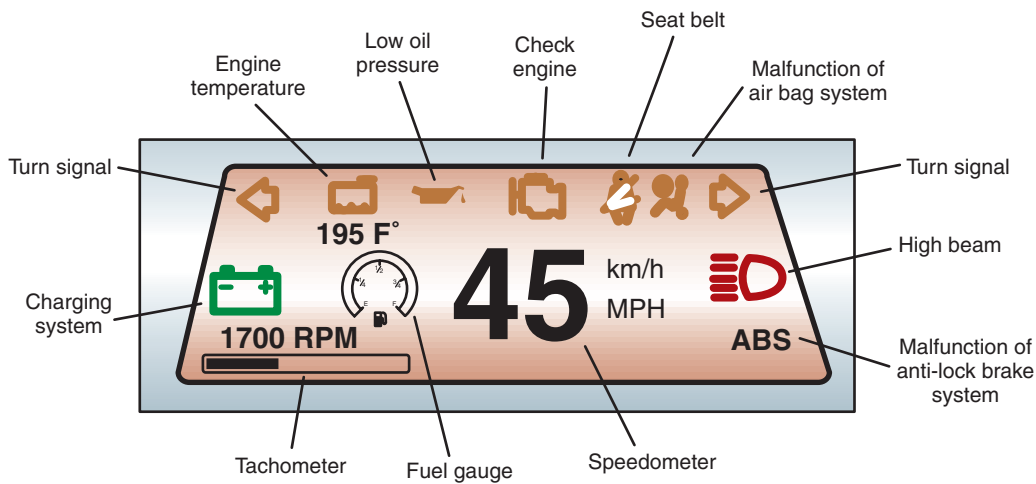
## Vehicle Instrumentation Systems

**Vehicle instrumentation systems** (Figure 1-7) monitor the various vehicle operating systems and provide information to the driver about their correct operation. Warning devices also provide information to the driver; however, they are usually associated with an audible signal. Some vehicles use a voice module to alert the driver to certain conditions.

## Electrical Accessories

**Electrical accessories** provide for additional safety and comfort. There are many electrical accessories that can be installed into today's vehicles. These include safety accessories such as the horn, windshield wipers, and windshield washers. Comfort accessories include the blower motor, electric defoggers, power mirrors, power windows, power seats, and power door locks.





**FIGURE 1-7** The instrument panel displays various operating conditions.



**FIGURE 1-8** Automotive horn.

**Horns.** A **horn** is a device that produces an audible warning signal (Figure 1-8). Automotive electrical horns operate on an electromagnetic principle that vibrates a diaphragm to produce a warning signal. This vibration of the diaphragm is repeated several times per second. As the diaphragm vibrates it causes a column of air that is in the horn to vibrate. The vibration of the column of air produces the sound.

**Windshield Wipers.** **Windshield wipers** are mechanical arms that sweep back and forth across the windshield to remove water, snow, or dirt (Figure 1-9). The operation of the wiper arms is through the use of a wiper motor. Most windshield wiper motors use permanent magnet fields, or electromagnetic field motors.

**Electric Defoggers.** **Electric defoggers** heat the rear window to remove ice and/or condensation. Some vehicles use the same circuit to heat the outside driver-side mirror. When electrons are forced to flow through a resistance, heat is generated. Rear window defoggers use this principle of controlled resistance to heat the glass. The resistance is through a grid that is baked on the inside of the glass (Figure 1-10). The system may incorporate a timer circuit that controls the relay.

**Power Mirrors.** **Power mirrors** are outside mirrors that are electrically positioned from the inside of the driver compartment. The electrically controlled mirror allows the driver to



© Delmar/Cengage Learning

**FIGURE 1-9** Windshield wipers.



© Delmar/Cengage Learning

**FIGURE 1-10** Rear window defogger grid.

position the outside mirrors by use of a switch. The mirror assembly will use built-in, dual-drive, reversible permanent magnet (PM) motors.

**Power Windows.** **Power windows** are windows that are raised and lowered by use of electrical motors. Many vehicle manufacturers have replaced the conventional window crank with electric motors that operate the side windows. The motor used in the power window system is a reversible PM or two-field winding motor. The power window system usually consists of the following components:

1. Master control switch.
2. Individual control switches.
3. Individual window drive motors.

**Power Door Locks.** **Electric power door locks** use either a solenoid or a permanent magnet reversible motor to lock and unlock the door. Many vehicles are equipped with automatic door locks that are activated when the gear shift lever is placed in the DRIVE position. The doors unlock when the selector is returned to the PARK position.



© Delmar/Cengage Learning

**FIGURE 1-11** A control module is used to process data and operate different automotive systems.

## Computers

A **computer** is an electronic device that stores and processes data and is capable of operating other devices (Figure 1-11). The use of computers on automobiles has expanded to include control and operation of several functions, including climate control, lighting circuits, cruise control, antilock braking, electronic suspension systems, and electronic shift transmissions. Some of these are functions of what is known as a body control module (BCM). Some body computer-controlled systems include direction lights, rear window defogger, illuminated entry, intermittent wipers, and other systems that were once thought of as basic.

A computer processes the physical conditions that represent information (data). The operation of the computer is divided into four basic functions:

1. Input.
2. Processing.
3. Storage.
4. Output.

## Vehicle Communication Networks

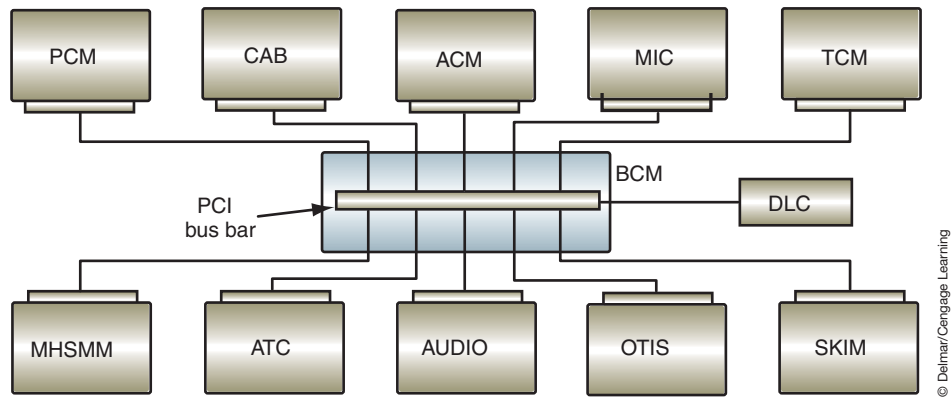
Most manufacturers now use a system of vehicle communications called **multiplexing** (MUX) to allow control modules to share information (Figure 1-12). Multiplexing provides the ability to use a single circuit to distribute and share data between several control modules throughout the vehicle. Because the data is transmitted through a single circuit, bulky wiring harnesses are eliminated.

Vehicle manufacturers will use multiplexing systems to enable different control modules to share information. A MUX wiring system uses **bus** data links that connect each module. The term *bus* refers to the transporting of data from one module to another. Each module can transmit and receive digital codes over the bus data links. The signal sent from a sensor can go to any one of the modules and can be shared by the other modules.

## Electronic Accessory Systems

With the growing use of computers, most systems can be controlled electronically. This provides for improved monitoring of the systems for proper operation and the ability to detect if a fault occurs. The systems that are covered in this book include the following:





**FIGURE 1-12** Automotive computers are networked together through multiplexing.

**Cruise control** systems are also referred to as *speed control*.

**Electronic Cruise Control Systems.** **Cruise control** is a system that allows the vehicle to maintain a preset speed with the driver's foot off of the accelerator. Most cruise control systems are a combination of electrical and mechanical components.

**Memory Seats.** The **memory seat** feature allows the driver to program different seat positions that can be recalled at the push of a button. The memory seat feature is an addition to the basic power seat system. Most memory seat systems share the same basic operating principles, the difference being in programming methods and number of positions that can be programmed. Most systems provide for two seat positions to be stored in memory.

An **easy exit** feature may be an additional function of the memory seat that provides for easier entrance and exit of the vehicle by moving the seat all the way back and down. Some systems also move the steering wheel up and to full retract.

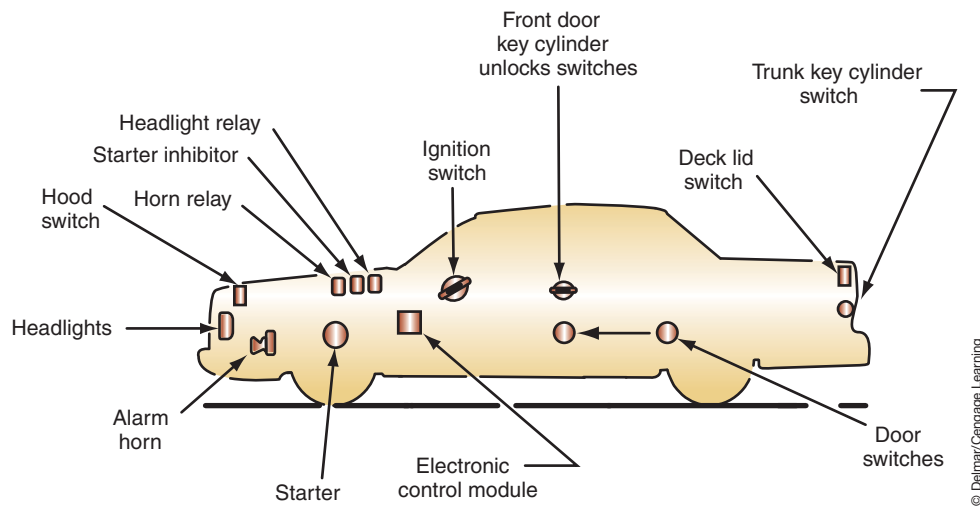
**Electronic Sunroofs.** Some manufacturers have introduced electronic control of their electric sunroofs. These systems incorporate a pair of relay circuits and a timer function into the control module. Motor rotation is controlled by relays that are activated according to signals received from the slide, tilt, and limit switches.

**Antitheft Systems.** The **antitheft system** is a deterrent system designed to scare off would-be thieves by sounding alarms and/or disabling the ignition system. Figure 1-13 illustrates many of the common components that are used in an antitheft system. These components include:

1. An electronic control module.
2. Door switches at all doors.
3. Trunk key cylinder switch.
4. Hood switch.
5. Starter inhibitor relay.
6. Horn relay.
7. Alarm.

In addition, many systems incorporate the exterior lights into the system. The lights are flashed if the system is activated.

Some systems use ultrasonic sensors that will signal the control module if someone attempts to enter the vehicle through the door or window. The sensors can be placed to sense the parameter of the vehicle and sound the alarm if someone enters within the protected parameter distance.



**FIGURE 1-13** Typical components of an anti-theft system.

**Automatic Door Locks.** **Automatic door locks (ADL)** use a passive system to lock all doors when the required conditions are met. Many automobile manufacturers are incorporating automatic door locks as an additional safety and convenience system. Most systems lock the doors when the gear selector is placed in DRIVE, the ignition switch in RUN, and all doors are shut. Some systems will lock the doors when the gear shift selector is passed through the REVERSE position, while others do not lock the doors unless the vehicle is moving 15 mph or faster.

The system may use the body computer or a separate controller to control the door lock relays. The controller (or body computer) takes the place of the door lock switches for automatic operation.

**Keyless Entry.** The **keyless entry system** allows the driver to unlock the doors or the deck lid (trunk) from outside of the vehicle without the use of a key. The main components of the keyless entry system are the control module, a coded-button keypad located on the driver's door (Figure 1-14), and the door lock motors.

Some keyless entry systems can be operated remotely. Pressing a button on a hand-held transmitter will allow operation of the system from distances of 25 to 50 feet (Figure 1-15).

Recently, most manufacturers have made available systems of remote engine starting and keyless start. These are usually designed into the function of the remote keyless entry system.



**FIGURE 1-14** Keyless entry system keypad.



**FIGURE 1-15** Remote keyless entry system transponder.

## Passive Restraint Systems

Federal regulations have mandated the use of automatic **passive restraint systems** in all vehicles sold in the United States after 1990. Passive restraints are ones that operate automatically, with no action required on the part of the driver or occupant.

**Air bag systems** are on all of today's vehicles. The need to supplement the existing restraint system during frontal collisions has led to the development of the supplemental inflatable restraint (SIR) or air bag systems (Figure 1-16).

A typical air bag system consists of sensors, a diagnostic module, a clock spring, and an air bag module. Figure 1-17 illustrates the typical location of the common components of the SIR system.

## Alternate Propulsion Systems

Due to the increase in regulations concerning emissions and the public's desire to become less dependent on foreign oil, most major automotive manufacturers have developed alternative fuel or alternate power vehicles. Since the 1990s, most major automobile manufacturers have developed an **electric vehicle (EV)**. The primary advantage of an

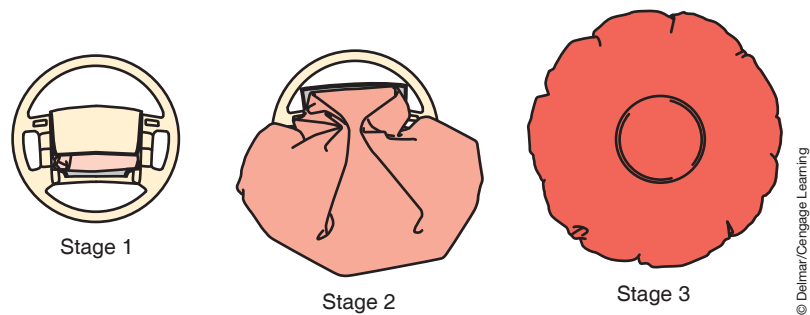


FIGURE 1-16 Air bag deployment sequence.

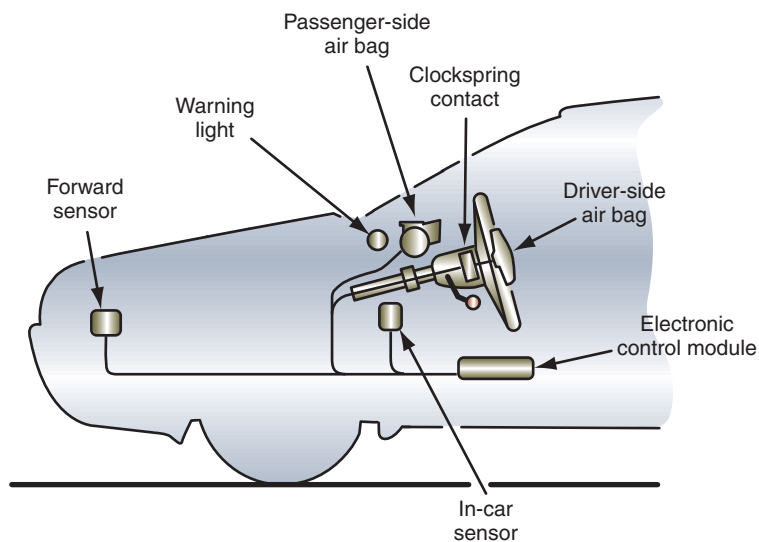


FIGURE 1-17 Typical location of components of the air bag system.

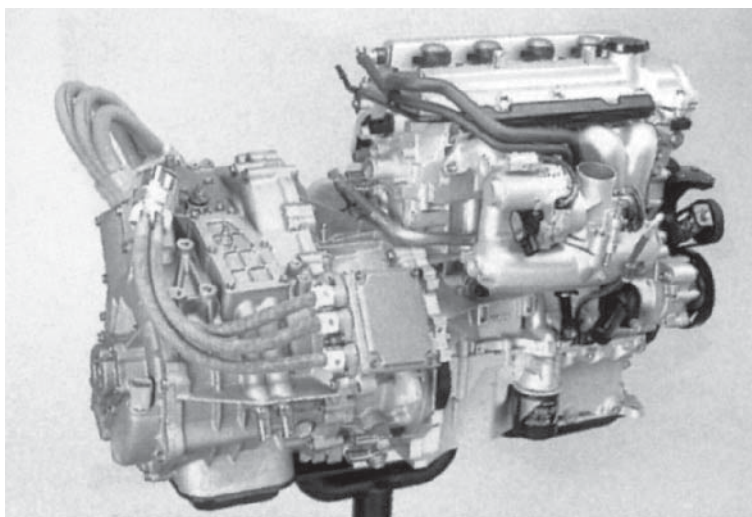
EV is a drastic reduction in noise and emission levels. General Motors introduced the EV1 electric car to the market in 1996. The original battery pack in this car contained twenty-six 12-volt batteries that delivered electrical energy to a three-phase 102-kilowatt (kW) AC electric motor. The electric motor is used to drive the front wheels. The driving range is about 70 miles (113 km) of city driving or 90 miles (145 km) of highway driving.

EV battery limitation was a major stumbling block to most consumers. One method of improving the electric vehicle resulted in the addition of an on-board power generator that is assisted by an internal combustion engine, resulting in the **hybrid electric vehicle (HEV)**.

Basically, the hybrid electric vehicle relies on power from the electric motor, the engine, or both (Figure 1-18). When the vehicle moves from a stop and has a light load, the electric motor moves the vehicle. Power for the electric motor comes from stored energy in the battery pack. During normal driving conditions, the engine is the main power source. Engine power is also used to rotate a generator that recharges the storage batteries. The output from the generator may also be used to power the electric motor, which is run to provide additional power to the powertrain. A computer controls the operation of the electric motor, depending on the power needs of the vehicle. During full throttle or heavy load operation, additional electricity from the battery is sent to the motor to increase the output of the powertrain.

**Fuel cell**–powered vehicles have a very good chance of becoming the drives of the future. They combine the reach of conventional internal combustion engines with high efficiency, low fuel consumption, and minimal or no pollutant emission. At the same time, they are extremely quiet. Because they work with regenerative fuel such as hydrogen, they reduce the dependence on crude oil and other fossil fuels.

A fuel cell–powered vehicle (Figure 1-19) is basically an electric vehicle. Like the electric vehicle, it uses an electric motor to supply torque to the drive wheels. The difference is that the fuel cell produces and supplies electric power to the electric motor instead of batteries. Most of the vehicle manufacturers and several independent laboratories are involved in fuel cell research and development programs. A number of prototype fuel cell vehicles have been produced, with many being placed in fleets in North America and Europe.



**FIGURE 1-18** HEV power system.

© Delmar/Cengage Learning

## TERMS TO KNOW

Air bag systems  
Antitheft system  
Automatic door locks (ADL)  
Bus  
Charging system  
Computer  
Cruise control  
Easy exit  
Electric defoggers  
Electric vehicle (EV)  
Electrical accessories  
Fuel cell  
Heated windshield system  
Horn  
Hybrid electric vehicle (HEV)  
Ignition switch  
Intelligent windshield wiper systems  
Keyless entry system  
Lighting system  
Memory seat  
Multiplexing  
Network  
Neutral safety switch  
Passive restraint systems  
Power door locks  
Power mirrors  
Power windows  
Starting system  
Vehicle instrumentation systems  
Voltage regulator  
Windshield wipers

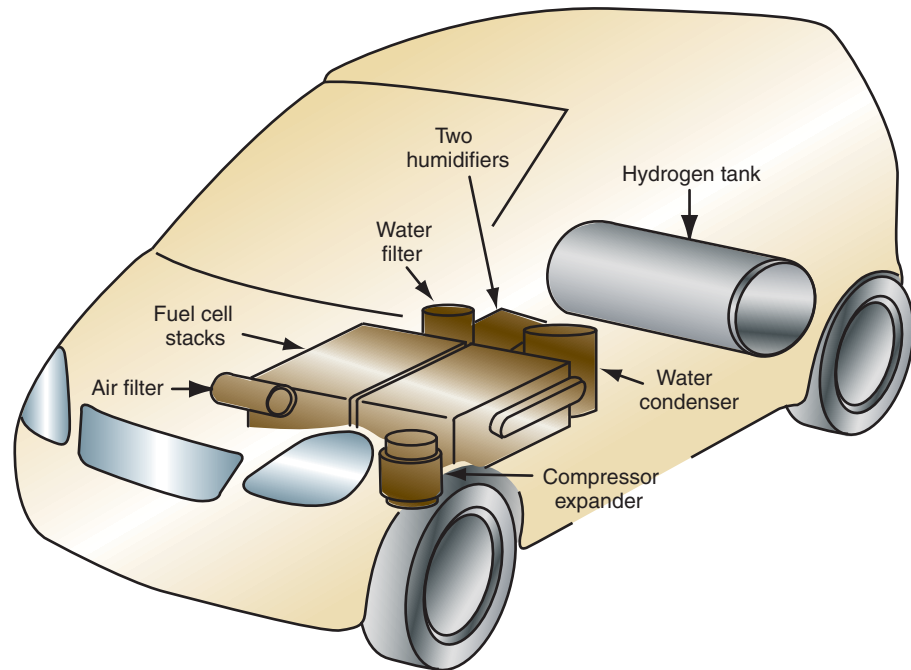


FIGURE 1-19 Fuel cell vehicle components.

© Delmar/Cengage Learning

## SUMMARY

- The starting system is a combination of mechanical and electrical parts that work together to start the engine.
- The charging system replaces the electrical power used by the battery and to provide current to operate all of the electrical accessories while the engine is running.
- The lighting system consists of all of the lights used on the vehicle.
- Vehicle instrumentation systems monitor the various vehicle operating systems and provide information to the driver.
- Electrical accessories provide additional safety and comfort.
- Many of the basic electrical accessory systems have electronic controls added to them to provide additional features and enhancement.
- Computers are electronic devices that gather, store, and process data.
- Most vehicles use a multiplexing system to share information between computer systems.
- The memory seat feature allows the driver to program different seat positions that can be recalled at the push of a button.
- Some manufacturers have introduced electronic control of their electric sunroofs. These systems incorporate a pair of relay circuits and a timer function into the control module.
- Antitheft systems are deterrent systems designed to scare off would-be thieves by sounding alarms and/or disabling the ignition system.
- Automatic door locks is a passive system used to lock all doors when the required conditions are met. Many automobile manufacturers are incorporating the system as an additional safety and convenience feature.
- Passive restraints operate automatically, with no action required on the part of the driver or occupant.
- Electric vehicles powered by an electric motor run off a battery pack.
- The hybrid electric vehicle relies on power from the electric motor, the engine, or both.
- A fuel cell–powered vehicle is basically an electric vehicle, except that the fuel cell produces and supplies electric power to the electric motor instead of batteries.

## REVIEW QUESTIONS

---

### Short-Answer Essays

1. Describe your level of comfort concerning automotive electrical systems.
  2. Explain why you feel it is important to understand the operation of the automotive electrical system.
  3. Explain how the use of computers has changed the automotive electrical system.
  4. Explain the difference between an electric vehicle and a fuel-cell vehicle.
  5. Explain the basics of HEV operation.
  6. What is the purpose of the keyless entry system?
  7. What safety benefits can be achieved from the automatic door lock system?
  8. What is the purpose of the starting system?
  9. What is the purpose of the charging system?
  10. What is the function of the air bag system?
2. Vehicle instrumentation systems \_\_\_\_\_ the various operating systems and provide information to the driver about their correct operation.
  3. A \_\_\_\_\_ is an electronic device that stores and processes data.
  4. The starting system is designed to change the \_\_\_\_\_ energy into mechanical energy.
  5. The \_\_\_\_\_ \_\_\_\_\_ feature is an additional function of the memory seat that provides for easier entrance and exit of the vehicle.
  6. The \_\_\_\_\_ \_\_\_\_\_ is the power distribution point for most of the vehicle's primary electrical systems.
  7. The \_\_\_\_\_ system is a deterrent system.
  8. The purpose of the charging system is to convert the \_\_\_\_\_ energy of the engine into \_\_\_\_\_ energy.
  9. \_\_\_\_\_ restraints operate automatically with no action required on the part of the driver.
  10. The \_\_\_\_\_ \_\_\_\_\_ uses an on-board power generator that is assisted by an internal combustion engine.

### Fill in the Blanks

1. Today, most manufactures \_\_\_\_\_ their electrical systems together through computers.

## MULTIPLE CHOICE

---

1. Electric vehicles power the motor by:
  - A. A generator.
  - B. A battery pack.
  - C. An engine.
  - D. None of the above.
2. The charging system:
  - A. Provides all electrical energy to operate the electrical system while the engine is running.
  - B. Restores the energy to the battery after starting the engine.
  - C. Uses the principle of magnetic induction to generate electrical power.
  - D. All of the above.
3. The memory seat system:
  - A. Operates separately of the power seat system.
  - B. Requires the vehicle to be moving before the seat position can be recalled.
  - C. Allows for the driver to program different seat positions that can be recalled at the push of a button.
  - D. Can only be equipped on vehicles with manual position seats.
4. The following are true about the easy exit feature EXCEPT:
  - A. It is an additional function of the memory seat.
  - B. The driver's door is opened automatically.
  - C. The seat is moved all the way back and down.
  - D. The system may move the steering wheel up.



5. The following are components of the starting system EXCEPT:
- A. The flywheel ring gear.
  - B. Neutral safety switch.
  - C. Harmonic balancer.
  - D. Battery.
6. Which of the following is the most correct statement?
- A. Automotive electrical systems are interlinked with each other.
  - B. All automotive electrical systems function the same on every vehicle.
  - C. Manufactures are required by Federal legislation to limit the number of computers used on today's vehicles.
  - D. All of the above.
7. Automotive horns operate on the principle of:
- A. Induced voltage.
  - B. Depletion zone bonding.
  - C. Frequency modulation.
  - D. Electromagnetism.
8. The purpose of multiplexing is to:
- A. Increase circuit loads to a sensor.
  - B. Prevent electromagnetic interference.
  - C. Allow computers to share information.
  - D. Prevent multiple system failures from occurring.
9. The following are true about the air bag system EXCEPT:
- A. It is an active system.
  - B. It is a supplemental system.
  - C. It is mandated by the federal government.
  - D. Deployment is automatic.
10. Alternate propulsion systems include:
- A. Electric vehicles.
  - B. Hybrid vehicles.
  - C. Fuel cell vehicles.
  - D. All of the above.

## Chapter 2

# BASIC THEORIES

### UPON COMPLETION AND REVIEW OF THIS CHAPTER, YOU SHOULD BE ABLE TO:

- Explain the theories and laws of electricity.
- Describe the difference between insulators, conductors, and semiconductors.
- Define voltage, current, and resistance.
- Define and use Ohm's law correctly.
- Explain the basic concepts of capacitance.
- Explain the difference between AC and DC currents.
- Define and illustrate series, parallel, and series-parallel circuits and the electrical laws that govern them.
- Explain the theory of electromagnetism.
- Explain the principles of induction.

### INTRODUCTION

The electrical systems used in today's vehicles can be very complicated (Figure 2-1). However, through an understanding of the principles and laws that govern electrical circuits, technicians can simplify their job of diagnosing electrical problems. In this chapter, you will learn the laws that dictate electrical behavior, how circuits operate, the difference between types of circuits, and how to apply Ohm's law to each type of circuit. You will also learn the basic theories of semiconductor construction. Because magnetism and electricity are closely related, a study of electromagnetism and induction is included in this chapter.

### BASICS OF ELECTRON FLOW

Because electricity is an energy form that cannot be seen, some technicians regard the vehicle's electrical system as being more complicated than it is. These technicians approach the vehicle's electrical system with some reluctance. It is important for today's technician to understand that electrical behavior is confined to definite laws that produce predictable results and effects. To facilitate the understanding of the laws of electricity, a short study of atoms is presented.

### Atomic Structure

An **atom** is the smallest part of a chemical element that still has all the characteristics of that element. An atom is constructed of a fixed arrangement of **electrons** in orbit around a **nucleus**—much like planets orbiting the sun (Figure 2-2). **Electrons** are negatively charged particles. The nucleus contains positively charged particles called **protons** and particles that have no charge, which are called **neutrons**. The protons and neutrons that make up the nucleus are tightly bound together. The electrons are free to move within their orbits at fixed distances around the nucleus. The attraction between the negative electrons and the positive protons causes the electrons to orbit the nucleus. All of the electrons surrounding the



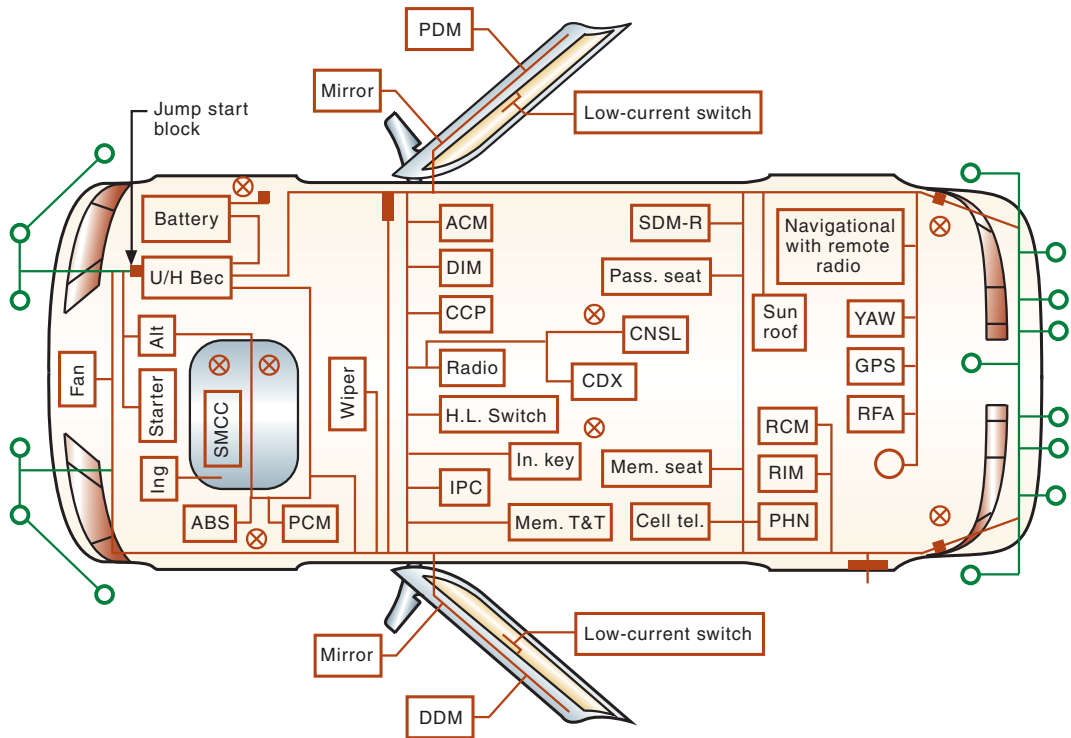


FIGURE 2-1 The electrical system of today's vehicle can be complicated.

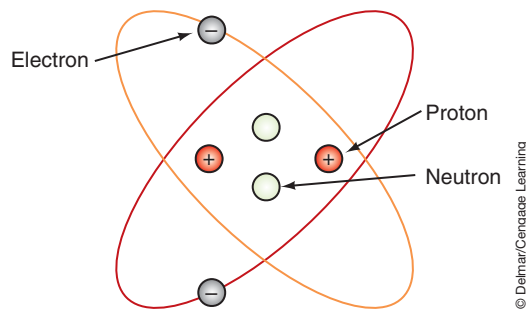


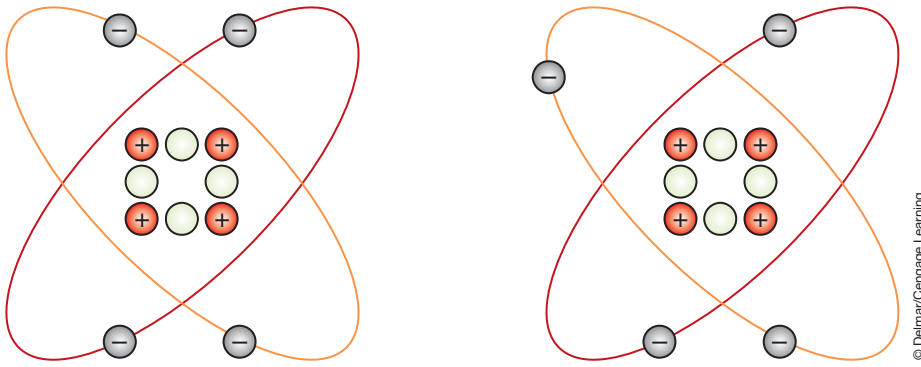
FIGURE 2-2 The basic construction of an atom.

nucleus are negatively charged, so they repel each other when they get too close. The electrons attempt to stay as far away from each other as possible without leaving their orbits.

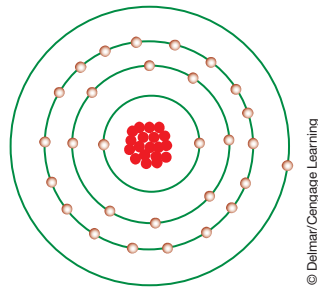
Atoms attempt to have the same number of electrons as there are protons in the nucleus. This makes the atom **balanced** (Figure 2-3). To remain balanced, an atom will shed an electron or attract an electron from another atom. A specific number of electrons are in each of the electron orbit paths. The orbit closest to the nucleus has room for 2 electrons; the second orbit holds up to 8 electrons; the third holds up to 18; and the fourth and fifth hold up to 32 each. The number of orbits depends on the number of electrons the atom has. For example, a copper atom contains 29 electrons; 2 in the first orbit, 8 in the second, 18 in the third orbit, and 1 in the fourth (Figure 2-4). The outer orbit, or **shell** as it is sometimes called, is referred to as the **valence ring**. This is the orbit we care about in our study of electricity.

In studying the laws of electricity, the only concern is with the electrons that are in the valence ring. Since an atom seeks to be balanced, an atom that is missing electrons in its valence ring will attempt to gain other electrons from neighboring atoms. Also, if the atom has an excess amount of electrons in its valence ring, it will try to pass them on to neighboring atoms.

Like charges repel each other; unlike charges attract each other.



**FIGURE 2-3** If the number of electrons and protons in an atom are the same, the atom is balanced.



**FIGURE 2-4** Basic structure of a copper atom.

## Conductors and Insulators

To help explain why you need to know about these electrons and their orbits, let's continue to look at the atomic structure of copper. Copper is a metal and is the most commonly used **conductor** of electricity. A conductor is something that supports the flow of electricity through it. As stated earlier, the copper atom has 29 electrons and 29 protons, but there is only 1 electron in the valence ring. For the valence ring to be completely filled, it would require 32 electrons. Since there is only 1 electron, it is loosely tied to the atom and can be easily removed, making it a good conductor.

Copper, silver, gold, and other good conductors of electricity have only one or two electrons in their valence ring. These atoms can be made to give up the electrons in their valence ring with little effort.

Since electricity is the movement of electrons from one atom to another, atoms that have one to three electrons in their valence ring support electricity. They allow the electron to easily move from the valence ring of one atom to the valence ring of another atom. Therefore, if we have a wire made of millions of copper atoms, we have a good conductor of electricity. To have electricity, we simply need to add one electron to one of the copper atoms. That atom will shed the electron it had to another atom, which will shed its original electron to another, and so on. As the electrons move from atom to atom, a force is released. This force is what we use to light lamps, run motors, and so on. As long as we keep the electrons moving in the conductor, we have electricity.

**Insulators** are materials that don't allow electrons to flow through them easily. Insulators are atoms that have five to eight electrons in their valence ring. The electrons are held tightly around the atom's nucleus and they can't be moved easily. Insulators are used to prevent electron flow or to contain it within a conductor. Insulating material covers the outside of most conductors to keep the moving electrons within the conductor.



### A BIT OF HISTORY

Electricity was discovered by the Greeks over 2,500 years ago. They noticed that when amber was rubbed with other materials it was charged with an unknown force that had the power to attract objects, such as dried leaves and feathers. The Greeks called amber "elektron." The word *electric* is derived from this word and means "to be like amber."

In summary, the number of electrons in the valence ring determines whether an atom is a good conductor or insulator. Some atoms are not good insulators or conductors; these are called **semiconductors**. In short:

1. Three or fewer electrons—conductor.
2. Five or more electrons—insulator.
3. Four electrons—semiconductor.

Random movement of electrons is not electric current; the electrons must move in the same direction.

The speed of light is 186,000 miles per second (299,000 kilometers per second).

An *E* can be used for the symbol to designate voltage (electromotive force). A *V* is also used as a symbol for voltage.

**Shop Manual**  
Chapter 2, page 47

One volt (V) is the amount of pressure required to move one ampere of current through one ohm of resistance.

## ELECTRICITY DEFINED

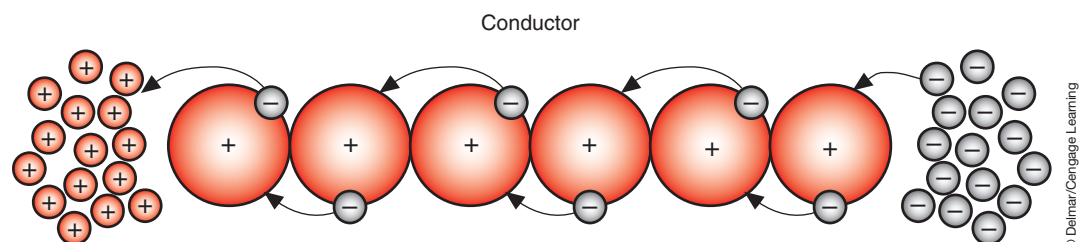
Electricity is the movement of electrons from atom to atom through a conductor (Figure 2-5). Electrons are attracted to protons. Since we have excess electrons on the other end of the conductor, we have many electrons being attracted to the protons. This attraction sort of pushes the electrons toward the protons. This push is normally called electrical pressure. The amount of electrical pressure is determined by the number of electrons that are attracted to protons. The electrical pressure or **electromotive force (EMF)** attempts to push an electron out of its orbit and toward the excess protons. If an electron is freed from its orbit, the atom acquires a positive charge because it now has one more proton than it has electrons. The unbalanced atom or **ion** attempts to return to its balanced state so it will attract electrons from the orbit of other **balanced atoms**. This starts a chain reaction as one atom captures an electron and another releases an electron. As this action continues to occur, electrons will flow through the conductor. A stream of free electrons forms and an electrical current is started. This does not mean a single electron travels the length of the insulator; it means the overall effect is electrons moving in one direction. All this happens at the speed of light. The strength of the electron flow is dependent on the potential difference or voltage.

The three elements of electricity are voltage, current, and resistance. How these three elements interrelate governs the behavior of electricity. Once the technician comprehends the laws that govern electricity, understanding the function and operation of the various automotive electrical systems is an easier task. This knowledge will assist the technician in diagnosis and repair of automotive electrical systems.

## Voltage

**Voltage** can be defined as an electrical pressure (Figure 2-6) and is the electromotive force (EMF) that causes the movement of the electrons in a conductor. In Figure 2-5, voltage is the force of attraction between the positive and negative charges. An electrical pressure difference is created when there is a mass of electrons at one point in the circuit, and a lack of electrons at another point in the circuit. In the automobile, the battery or generator is used to apply the electrical pressure.

The amount of pressure applied to a circuit is stated in the number of volts. If a voltmeter is connected across the terminals of an automobile battery, it may indicate 12.6 volts. This is actually indicating that there is a difference in potential of 12.6 volts. There is 12.6 volts of electrical pressure between the two battery terminals.



**FIGURE 2-5** As electrons flow in one direction from one atom to another, an electrical current is developed.

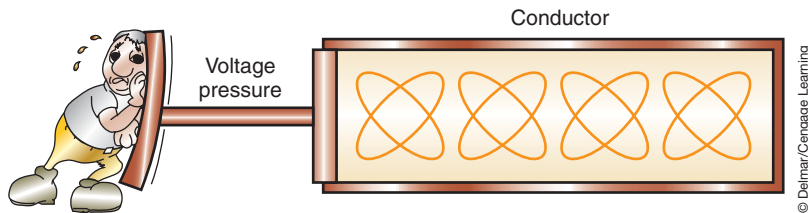


FIGURE 2-6 Voltage is the pressure that causes the electrons to move.

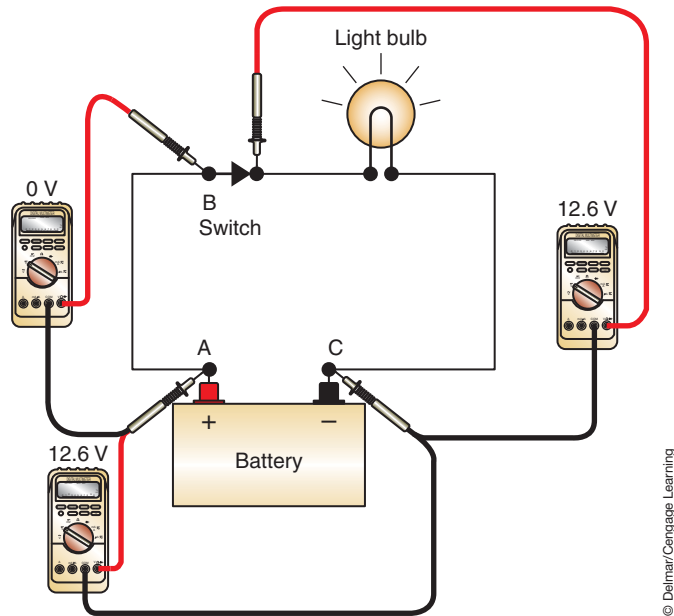


FIGURE 2-7 A simplified light circuit illustrating voltage potential.

In a circuit that has current flowing, voltage will exist between any two points in that circuit (Figure 2-7). The only time voltage does not exist is when the potential drops to zero. In Figure 2-7 the voltage potential between points A and C and between points B and C is 12.6 volts. However, between points A and B the pressure difference is zero and the voltmeter will indicate 0 volts.

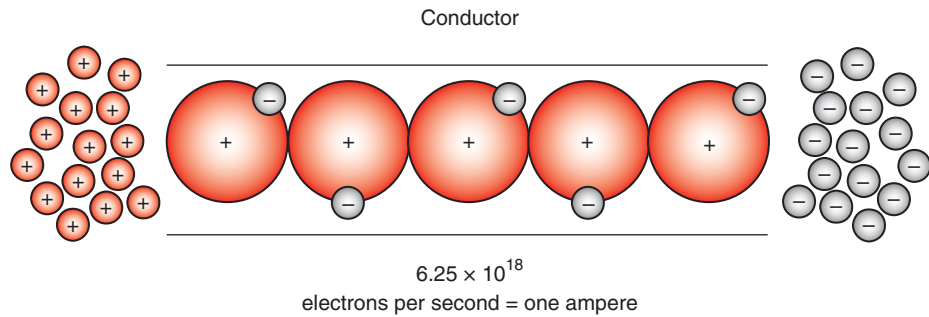
## Current

**Current** can be defined as the *rate* (intensity) of electron flow (Figure 2-8) and is measured in amperes. Current is a measurement of the electrons passing any given point in the circuit in one second. Because the flow of electrons is at the speed of light, it would be impossible to physically see electron flow. However, the rate of electron flow can be measured. Current will increase as pressure or voltage is increased—provided circuit resistance remains constant.

An electrical current will continue to flow through a conductor as long as the electromotive force is acting on the conductor's atoms and electrons. If a potential exists in the conductor, with a build up of excess electrons at the end of the conductor farthest from the EMF and there is a lack of electrons at the EMF side, current will flow. The effect is called electron drift and accounts for the method in which electrons flow through a conductor.

**Shop Manual**  
Chapter 2, page 51

**One ampere (A)** represents the movement of  $6.25 \times 10^{18}$  electrons (or one coulomb) past one point in a conductor in one second.



**FIGURE 2-8** The rate of electron flow is called current and is measured in amperes.

The symbol for current is “I”, which stands for intensity. Also “A” is used for amperage.

An electrical current can be formed by the following forces: friction, chemical reaction, heat, pressure, and magnetic induction. Whenever electrons flow or drift in mass, an electrical current is formed. There are six laws that regulate this electrical behavior:

1. Like charges repel each other.
2. Unlike charges attract each other.
3. A voltage difference is created in the conductor when an EMF is acting on the conductor.
4. Electrons flow only when a voltage difference exists between the two points in a conductor.
5. Current tends to flow to ground in an electrical circuit as a return to source.
6. **Ground** is defined as the baseline when measuring electrical circuits, and is the point of lowest voltage. Also, it is the return path to the source for an electrical circuit. The ground circuit used in most automotive systems is through the vehicle chassis and/or engine block. In addition, ground allows voltage spikes to be directed away from the circuit by absorbing them.

So far we have described current as the movement of electrons through a conductor. Electrons move because of a potential difference. This describes one of the common theories about current flow. The **electron theory** states that since electrons are negatively charged, current flows from the most negative to the most positive point within an electrical circuit. In other words, current flows from negative to positive. This theory is widely accepted by the electronic industry.

Another current flow theory is called the **conventional theory**. This states that current flows from positive to negative. The basic idea behind this theory is simply that although electrons move toward the protons, the energy or force that is released as the electrons move begins at the point where the first electron moved to the most positive charge. As electrons continue to move in one direction, the released energy moves in the opposite direction. This theory is the oldest theory and serves as the basis for most electrical diagrams.

Trying to make sense of it all may seem difficult. It is also difficult for scientists and engineers. In fact, another theory has been developed to explain the mysteries of current flow. This theory is called the hole-flow theory and is actually based on both electron theory and the conventional theory.

As a technician, you will find references to all of these theories. Fortunately, it really doesn't matter as long as you know what current flow is and what affects it. From this understanding, you will be able to figure out how the circuit basically works, how to test it, and how to repair it. In this text, we will present current flow as moving from positive to negative and electron flow as moving from negative to positive. Remember that current flow is the result of the movement of electrons, regardless of the theory.



## A BIT OF HISTORY

The ampere is named after André Ampère, who in the late 1700s worked with magnetism and current flow to develop some foundations for understanding the behavior of electricity.



## Resistance

The third component in electricity is **resistance**. Resistance is the opposition to current flow and is measured in **ohms**. In a circuit, resistance controls the amount of current. The size, type, length, and temperature of the material used as a conductor will determine its resistance. Devices that use electricity to operate (motors and lights) have a greater amount of resistance than the conductor.

A complete electrical **circuit** consists of the following: (1) a power source, (2) a load or resistance unit, and (3) conductors. Resistance (load) is required to change electrical energy to light, heat, or movement. There is resistance in any working device of a circuit, such as a lamp, motor, relay, coil, or other load component.

**There are five basic characteristics that determine the amount of resistance in any part of a circuit:**

1. The atomic structure of the material: The higher the number of electrons in the outer valence ring, the higher the resistance of the material.
2. The length of the conductor: The longer the conductor, the higher the resistance.
3. The diameter of the conductor: The smaller the cross-sectional area of the conductor, the higher the resistance.
4. Temperature: Normally an increase of temperature of the conductor causes an increase in the resistance.
5. Physical condition of the conductor: If the conductor is damaged by nicks or cuts, the resistance will increase because the conductor's diameter is decreased by these.

There may be unwanted resistance in a circuit. This could be in the form of a corroded connection or a broken conductor. In these instances, the resistance may cause the load component to operate at reduced efficiency or to not operate at all.

**It does not matter if the resistance is from the load component or from unwanted resistance. There are certain principles that dictate its impact in the circuit:**

1. Voltage always drops as current flows through the resistance.
2. An increase in resistance causes a decrease in current.
3. All resistances change the electrical energy into heat energy to some extent.

## Voltage Drop Defined

Voltage drop occurs when current flows through a load component or resistance. Voltage drop is the amount of electrical energy that is converted as it pushes current flow through a resistance. Electricity is an energy. Energy cannot be created or destroyed but it can be changed. As electrical energy flows through a resistance, it is converted to some other form of energy, usually heat energy. The amount of voltage drop over a resistance or load device is an indication of how much electrical energy was converted to another energy form. After a resistance, the voltage is lower than it was before the resistance.

Voltage drop can be measured by using a voltmeter (Figure 2-9). With current flowing through a circuit, the voltmeter may be connected in parallel over the resistor, wire, or component to measure voltage drop. The voltmeter indicates the amount of voltage potential between two points in the circuit. The voltmeter reading indicates the difference between the amount of voltage available to the resistor and the amount of voltage after the resistor.

There must be a voltage present for current to flow through a resistor. Kirchhoff's law basically states that the sum of the voltage drops in an electrical circuit will always equal source voltage. In other words, all of the source's voltage is used by the circuit.

**Shop Manual**  
Chapter 2, page 50

The **ohm ( $\Omega$ )** is the unit of measurement for resistance of a conductor such that a constant current of 1 ampere in it produces a voltage of 1 volt between its ends.

The symbol for resistance is *R*.

**Shop Manual**  
Chapter 2, page 48





## A BIT OF HISTORY

Gustav Kirchhoff was a German scientist who, in the 1800s, discovered two facts about the characteristics of electricity. One is called his voltage law, which states “The sum of the voltage drops across all resistances in a circuit must equal the voltage of the source.” His law on current states “The sum of the currents flowing into any point in a circuit equals the sum of the currents flowing out of the same point.” These laws describe what happens when electricity is applied to a load. Voltage drops while current remains constant; current does not drop.

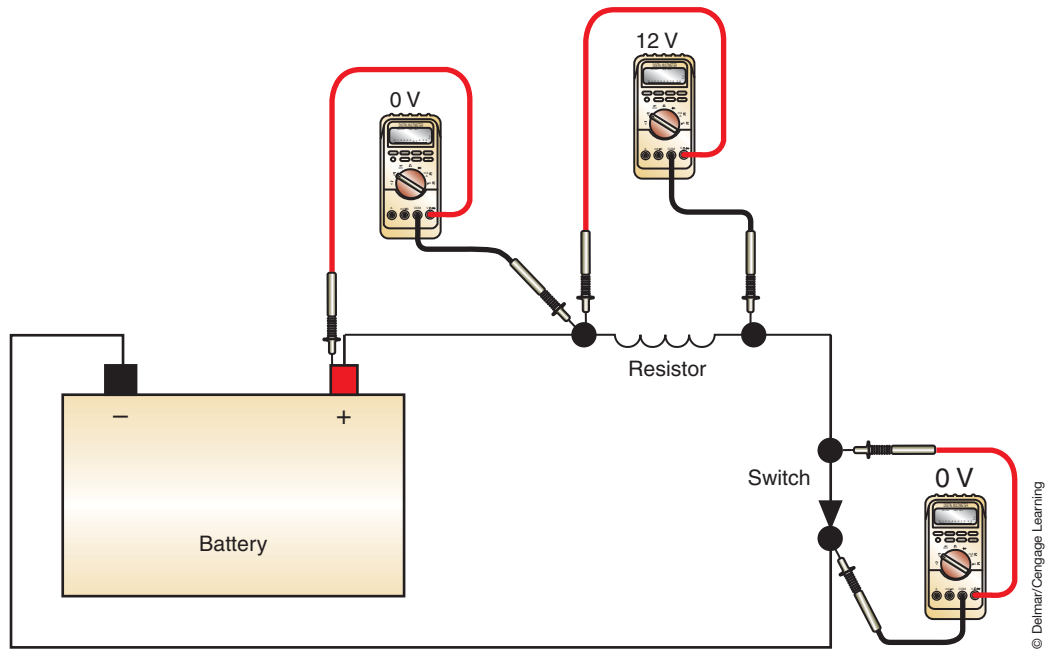


FIGURE 2-9 Using a voltmeter to measure voltage drop in different locations of a circuit.

© Delmar/Cengage Learning

## ELECTRICAL LAWS

Electricity is governed by well-defined laws. The most fundamental of these are Ohm’s law and Watt’s law. Today’s technician must understand these laws in order to completely grasp electrical theory.

### Ohm’s Law

Understanding **Ohm’s law** is the key to understanding how electrical circuits work. Ohm’s law defines the relationship between current, voltage, and resistance. The law states that it takes one volt of electrical pressure to push one ampere of electrical current through one ohm of electrical resistance. This law can be expressed mathematically as:

$$1 \text{ Volt} = 1 \text{ Ampere} \times 1 \text{ Ohm}$$

This formula is most often expressed as:  $E = I \times R$ .  $E$  stands for electromotive force (electrical pressure or voltage),  $I$  stands for intensity (current or ampere), and  $R$  represents resistance. This formula is often used to find the amount of one electrical characteristic when the other two are known. As an example: if we have 2 amps of current and 6 ohms of resistance in a circuit, we must have 12 volts of electrical pressure.

$$E = 2 \text{ Amps} \times 6 \text{ Ohms} \quad E = 2 \times 6 \quad E = 12 \text{ Volts}$$

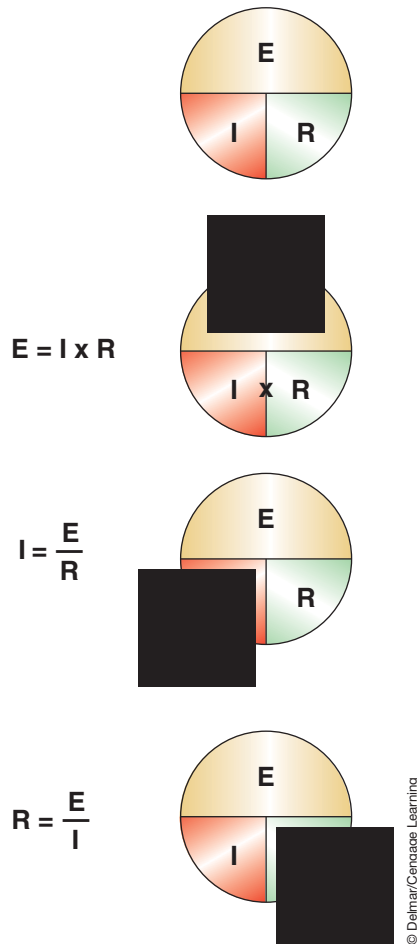
If we know the voltage and resistance but not the current of a circuit, we can quickly calculate it by using Ohm’s law. Since  $E = I \times R$ ,  $I$  would equal  $E$  divided by  $R$ . Let’s supply some numbers to this. If we have a 12-volt circuit with 6 ohms of resistance, we can determine the amount of current in this way:

$$I = \frac{E}{R} \quad \text{or} \quad \frac{12 \text{ Volts}}{6 \text{ Ohms}} \quad \text{or} \quad I = 2 \text{ Amps}$$

The same logic is used to calculate resistance when voltage and current are known.  $R = E/I$ . One easy way to remember the formulas of Ohm’s law is to draw a circle and divide it into three parts as shown in Figure 2-10. Simply cover the value you want to calculate. The formula you need to use is all that shows.

To show how easily this works, consider the 12-volt circuit in Figure 2-11. This circuit contains a 3-ohm light bulb. To determine the current in the circuit, cover the  $I$  in the circle

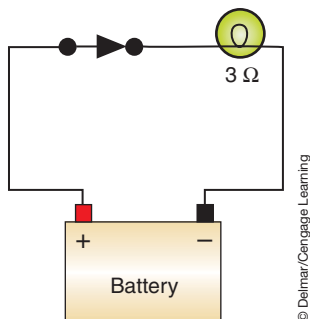
The resistance of an actual lamp in an automotive application will change when current passes through it because its temperature changes.



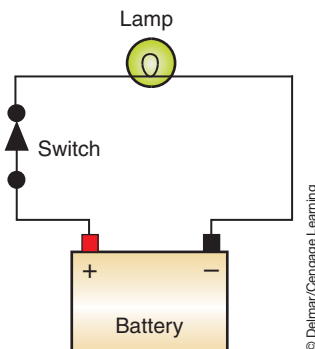
**FIGURE 2-10** The mathematical formula for Ohm's law using a circle to help understand the different formulas that can be derived from it. To expose the formula to use, cover the unknown value.

to expose the formula  $I = E/R$ . Then plug in the numbers,  $I = 12/3$ . Therefore, the circuit current is 4 amperes.

To further explore how Ohm's law works, refer to Figure 2-12 of a simple circuit. If the battery voltage is 12 volts and the amperage is 24 amperes, the resistance of the lamp can be determined using  $R = E/I$ . In this instance, the resistance is  $.5 \Omega$ . For another example, if the resistance of the bulb is  $2 \Omega$  and the amperage is 12, then voltage can be found using  $E = I \times R$ . In this instance, voltage would equal 24 volts. Now, if the circuit had 12 volts and the resistance of the bulb was  $2 \Omega$ , then amperage could be determined by  $I = E/R$ . In this case, amperage would be 6 amperes.



**FIGURE 2-11** Simplified light circuit with 3 ohms of resistance in the lamp.

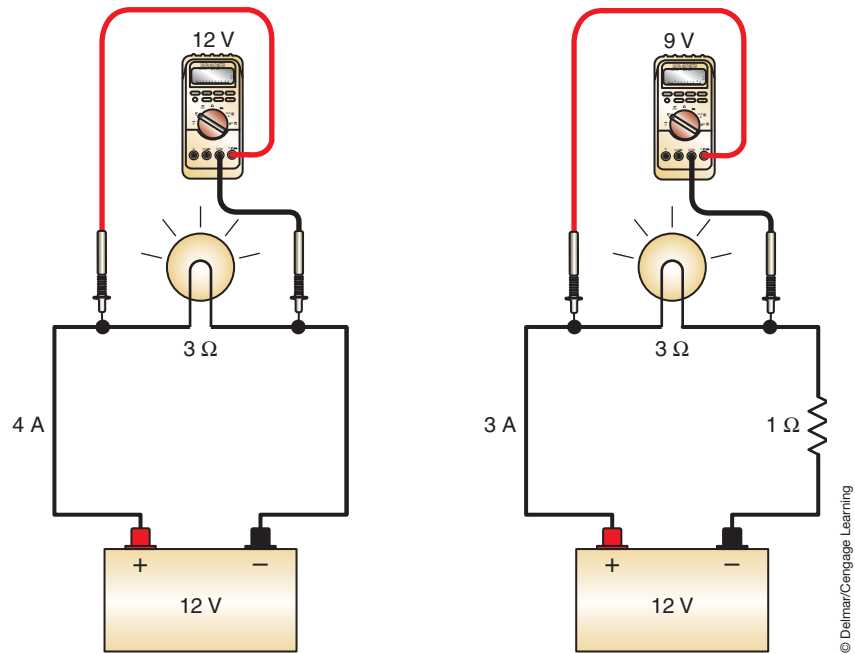


**FIGURE 2-12** Simple lamp circuit to help use Ohm's law.



## A BIT OF HISTORY

Georg S. Ohm was a German scientist in the 1800s who discovered that all electrical quantities are proportional to each other and therefore have a mathematical relationship.



**FIGURE 2-13** The light circuit in Figure 2-11 shown with normal circuit values and with added resistance in series.

Ohm's law is the basic law of electricity. It states that the amount of current in an electric circuit is inversely proportional to the resistance of the circuit and it is directly proportional to the voltage in the circuit. For example, if the resistance decreases and the voltage remains constant, the amperage will increase. If the resistance stays the same and the voltage increases, the amperage will also increase.

For example, refer to Figure 2-13; on the left side is a 12-volt circuit with a 3-ohm light bulb. This circuit will have 4 amps of current flowing through it. If a 1-ohm resistor is added to the same circuit (as shown to the right in Figure 2-13), total resistance is now 4 ohms. Because of the increased resistance, current dropped to 3 amps. The light bulb will be powered by less current and will be less bright than it was before the additional resistance was added.

Another point to consider is voltage drop. Before adding the 1-ohm resistor, the source voltage (12 volts) was dropped by the light bulb. With the additional resistance, the voltage drop of the light bulb decreased to 9 volts. The remaining 3 volts were dropped by the 1-ohm resistor. This can be proven by using Ohm's law. When the circuit current was 4 amps, the light bulb had 3 ohms of resistance. To find the voltage drop, we multiply the current by the resistance.

$$E = I \times R \quad \text{or} \quad E = 4 \times 3 \quad \text{or} \quad E = 12$$

When the extra resistor was added to the circuit, the light bulb still had 3 ohms of resistance, but the current in the circuit decreased to 3 amps. Again voltage drop can be determined by multiplying the current by the resistance.

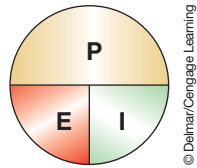
$$E = I \times R \quad \text{or} \quad E = 3 \times 3 \quad \text{or} \quad E = 9$$

The voltage drop of the additional resistor is calculated in the same way:  $E = I \times R$  or  $E \times 3$  volts. The total voltage drop of the circuit is the same for both circuits. However, the voltage drop at the light bulb changed. This also would cause the light bulb to be dimmer. Ohm's law and its application will be discussed in greater detail later.

## Watt's Law

**Power (P)** is the rate of doing electrical work. Power is expressed in **watts**. A watt is equal to 1 volt multiplied by 1 ampere. There is another mathematical formula that expresses the relationship between voltage, current, and power. It is simply:  $P = E \times I$  (Figure 2-14). Power measurements are measurements of the rate at which electricity is doing work.

It is possible to convert horsepower ratings to electrical power rating using the conversion factor: 1 horsepower equals 746 watts.



**FIGURE 2-14** The mathematical formula for Watt's law.

The best examples of power are light bulbs. Household light bulbs are sold by wattage. A 100-watt bulb is brighter and uses more electricity than a 60-watt bulb.

Referring back to Figure 2-13, the light bulb in the circuit on the left had a 12-volt drop at 4 amps of current. We can calculate the power the bulb uses by multiplying the voltage and the current.

$$P = E \times I \quad \text{or} \quad P = 12 \times 4 \quad \text{or} \quad P = 48$$

The power output of the bulb is 48 watts. When the resistor was added to the circuit, the bulb dropped 9 volts at 3 amps of current. The power of the bulb is calculated in the same way as before.

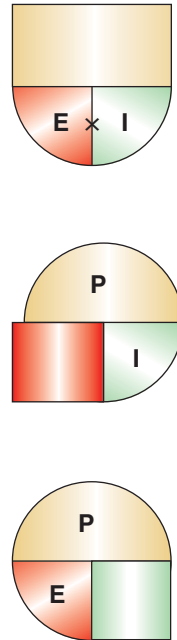
$$P = E \times I \quad \text{or} \quad P = 9 \times 3 \quad \text{or} \quad P = 27$$

This bulb produced 27 watts of power, a little more than half of the original. It would be almost half as bright. The key to understanding what happened is to remember the light bulb didn't change; the circuit changed.

Another example of using Watt's law is to determine the amperage if an additional accessory is added to the vehicle's electrical system. If the accessory is rated at 75 watts, the amperage draw would be:

$$I = P/E = 75/12 = 6.25 \text{ amps}$$

This tells the technician that this circuit will probably require a 10-amp rated fuse.

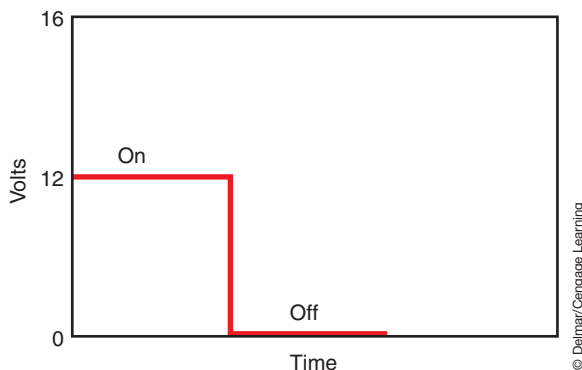


## TYPES OF CURRENT

There are two classifications of electrical current flow: direct current (DC) and alternating current (AC). The type of current flow is determined by the direction it flows and by the type of voltage that drives it.

### Direct Current

**Direct current (DC)** can only be produced by a chemical reaction (such as in a battery) and has a current that is the same throughout the circuit and flows in the same direction (Figure 2-15). Voltage and current are constant if the switch is turned on or off. Most of the electrically controlled units in the automobile require direct current.



**FIGURE 2-15** Direct current flow is in the same direction and remains constant on or off.

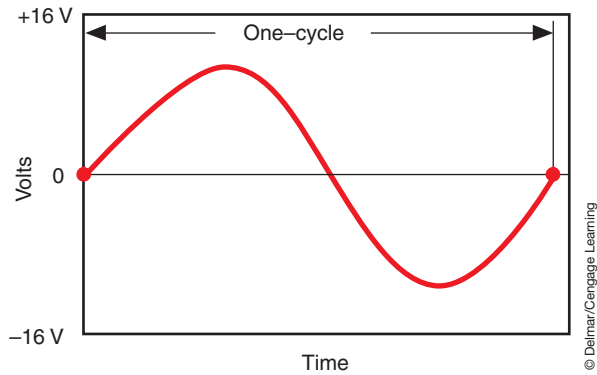


FIGURE 2-16 Alternating current does not remain constant.

The unrectified current produced within a generator is the most common example of alternating current found in the automobile. Generator circuits convert AC current to DC current.

The portion of the circuit from the positive side of the source to the load component is called the insulated side or “hot” side of the circuit. The portion of the circuit that is from the load component to the negative side of the source is called the ground side of the circuit.

The electrical term **closed circuit** means that there are no breaks in the path and current will flow. **Open circuit** is used to mean that current flow is stopped. By opening the circuit, the path for electron flow is broken.

## Alternating Current

**Alternating current (AC)** is produced anytime a conductor moves through a magnetic field. In an alternating current circuit, voltage and current do not remain constant. Alternating current changes directions from positive to negative. The voltage in an AC circuit starts at zero and rises to a positive value. Then it falls back to zero and goes to a negative value. Finally it returns to zero (Figure 2-16). The AC voltage, shown in Figure 2-16, is called a sine wave. Figure 2-16 shows one **cycle**.

## ELECTRICAL CIRCUITS

The electrical term *continuity* refers to the circuit being continuous. For current to flow, the electrons must have a continuous path from the source voltage to the load component and back to the source. A simple automotive circuit is made up of three parts:

1. Battery (power source).
2. Wires (conductors).
3. Load (light, motor, etc.).

The basic circuit shown (Figure 2-17) includes a switch to turn the circuit on and off, a protection device (fuse), and a load. When the switch is turned to the ON position, the circuit is referred to as a **closed circuit**. When the switch is in the OFF position, the circuit is referred to as an **open circuit**. In this instance, with the switch closed, current flows from the positive terminal of the battery through the light and returns to the negative terminal of the battery. To have a complete circuit, the switch must be closed or turned on. The effect of opening and closing the switch to control electrical flow would be the same if the switch was installed on the ground side of the light.

There are three different types of electrical circuits: (1) the series circuit, (2) the parallel circuit, and (3) the series-parallel circuit.

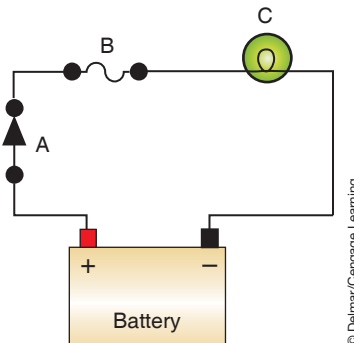


FIGURE 2-17 A basic electrical circuit including (A) a switch, (B) a fuse, and (C) a lamp.

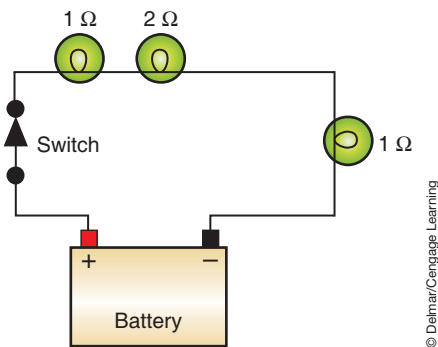
## Series Circuit

A **series circuit** consists of one or more resistors (or loads) with only one path for current to flow. If any of the components in the circuit fails, the entire circuit will not function. All of the current that comes from the positive side of the battery must pass through each resistor, then back to the negative side of the battery.

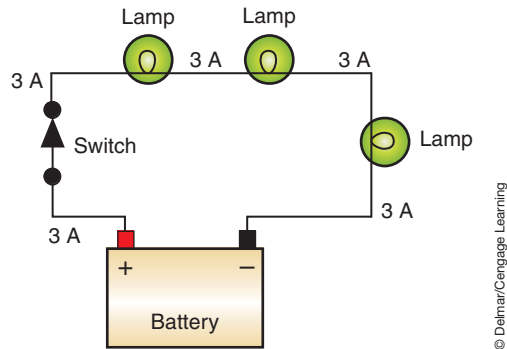
The total resistance of a series circuit is calculated by simply adding the resistances together. As an example, refer to Figure 2-18. Here is a series circuit with three light bulbs; one bulb has 2 ohms of resistance and the other two have 1 ohm each. The total resistance of this circuit is  $2 + 1 + 1$  or 4 ohms.

The characteristics of a series circuit are:

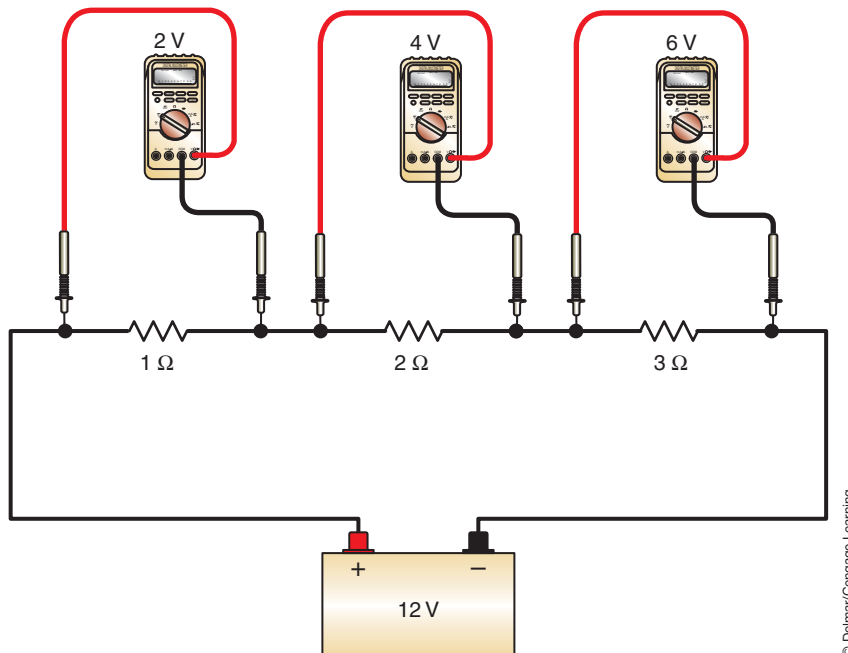
1. The total resistance is the sum of all resistances.
2. The current is the same at all points of the circuit (Figure 2-19).
3. The voltage drop across each resistance will be different if the resistance values are different (Figure 2-20).
4. The sum of all voltage drops equals the source voltage.



**FIGURE 2-18** The total resistance in a series circuit is the sum of all resistances in the circuit.

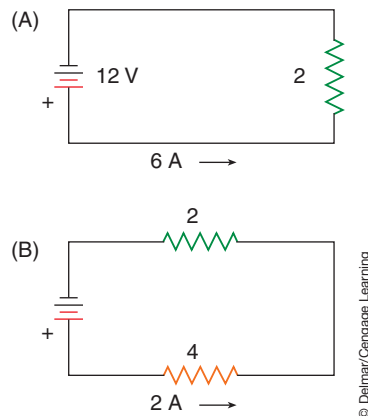


**FIGURE 2-19** Regardless of where it is measured, amperage is the same at all points in a series circuit.



**FIGURE 2-20** The voltage drop across each resistor in series will be different if the resistance values of each are different.





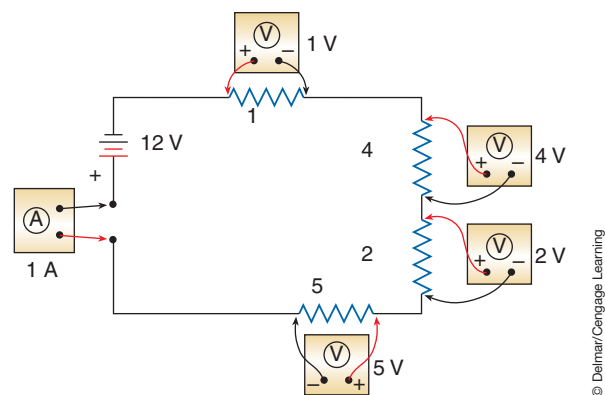
**FIGURE 2-21** Circuit resistance controls, or determines, the amount of current flow.

To illustrate the laws of the series circuit, refer to Figure 2-21. The illustration labeled (A) is a simple 12-volt series circuit with a  $2\ \Omega$  resistor. Using Ohm's law, it can be determined that the current is 6 amperes ( $A = V/R$ ). Since the  $2\ \Omega$  resistor is the only one in the circuit, all 12 volts are dropped across this resistor ( $V = A \times R$ ).

In Figure 2-21(B), an additional  $4\ \Omega$  resistor is added in series to the existing  $2\ \Omega$  resistor. Battery voltage is still 12 volts. Since this is a series circuit, total resistance is the sum of all of the resistance. In this case, total resistance is  $6\ \Omega$  ( $4\ \Omega + 2\ \Omega$ ). Using Ohm's law, total current through this circuit is 2 amperes ( $A = V/R = 12/6 = 2$ ). In a series circuit, current is the same at all points of the circuit. No matter where current was measured in this example, the meter would read 2 amperes. This means that 2 amperes of current is flowing through each of the resistors. By comparing the amperage flow of the two circuits in Figure 2-21, you can see that circuit resistance controls (or determines) the amount of current flow. Understanding this concept is critical to performing diagnostics. Since this is a series circuit, adding resistance will decrease amperage draw.

Using Ohm's law, voltage drop over each resistor in the circuit can be determined. In this instance,  $V$  is the unknown value. Using  $V = A \times R$  will determine the voltage drop over a resistance. Remember that amperage is the same throughout the circuit (2 amperes). The resistance value is the resistance of the resistor we are determining voltage drop for. For the  $2\ \Omega$  resistor, the voltage drop would be  $A \times R = 2 \times 2 = 4$  volts. Since the battery provides 12 volts and 4 volts are dropped over the  $2\ \Omega$  resistor, 8 volts are left to be dropped by the  $4\ \Omega$  resistor. To confirm this,  $V = A \times R = 2 \times 4 = 8$ . The sum of the voltage drops must equal the source voltage. Source voltage is 12 volts and the sum of the voltage drops is 4 volts + 8 volts = 12 volts.

These calculations work for all series circuits, regardless of the number of resistances in the circuit. Refer to Figure 2-22 for an example of a series circuit with four resistors.



**FIGURE 2-22** A series circuit used to demonstrate Ohm's law and voltage drop.

Total resistance is  $12\ \Omega$  ( $1\ \Omega + 4\ \Omega + 2\ \Omega + 5\ \Omega$ ). Total amperage is 1 amp ( $A = V/R = 12\ \text{volts}/12\ \Omega = 1\ \text{amp}$ ). Voltage drop over each resistor would be calculated as follows:

1. Voltage drop over the  $1\ \Omega$  resistor =  $A \times R = 1 \times 1 = 1\ \text{volt}$
  2. Voltage drop over the  $4\ \Omega$  resistor =  $A \times R = 1 \times 4 = 4\ \text{volts}$
  3. Voltage drop over the  $2\ \Omega$  resistor =  $A \times R = 1 \times 2 = 2\ \text{volts}$
  4. Voltage drop over the  $5\ \Omega$  resistor =  $A \times R = 1 \times 5 = 5\ \text{volts}$
- Total voltage drop = 12 volts

## Parallel Circuit

In a **parallel circuit**, each path of current flow has separate resistances that operate either independently or in conjunction with each other (depending on circuit design). In a parallel circuit, current can flow through more than one parallel leg at a time (Figure 2-23). In this type of circuit, failure of a component in one parallel leg does not affect the components in other legs of the circuit.

The legs of a **parallel circuit** are also called parallel branches or shunt circuits.

The characteristics of a parallel circuit are:

1. The voltage applied to each parallel leg is the same.
2. The voltage dropped across each parallel leg will be the same; however, if the leg contains more than one resistor, the voltage drop across each of them will depend on the resistance of each resistor in that leg.
3. The total resistance of a parallel circuit will always be less than the resistance of any of its legs.
4. The current flow through the legs will be different if the resistance is different.
5. The sum of the current in each leg equals the total current of the parallel circuit.

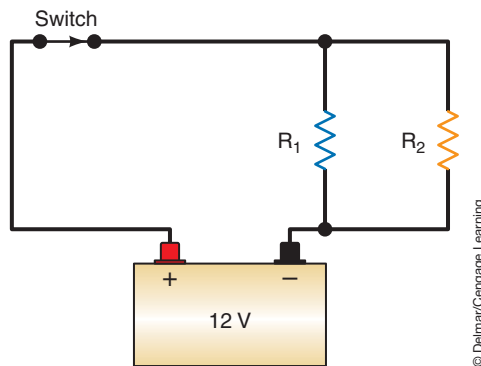
Figuring total resistance is a bit more complicated for a parallel circuit than a series circuit. Total resistance in a parallel circuit is always less than the lowest individual resistance because current has more than one path to follow. The method used to calculate total resistance depends on how many parallel branches are in the circuit, the resistance value of each branch, and personal preferences. Several methods of calculating total resistance are discussed. Choose the ones that work best for you.

If all resistances in the parallel circuit are equal, use the following formula to determine total resistance:

$$R_T = \frac{\text{Value of one resistor}}{\text{Total number of branches}}$$

For example, if the parallel circuit, shown in Figure 2-23, had a  $120\ \Omega$  resistor for  $R_1$  and  $R_2$ , total circuit resistance would be:

$$R_T = 120\ \Omega / 2\ \text{branches} = 60\ \Omega$$



**FIGURE 2-23** In a parallel circuit, there are multiple paths for current flow.

Note that total resistance is less than any of the resistances of the branches. If a third branch was added in parallel that also had 120  $\Omega$  resistance, total circuit resistance would be:

$$R_T = 120 \Omega / 3 \text{ branches} = 40 \Omega$$

Note what has happened when the third parallel branch was added. If more parallel resistors are added, more circuits are added, and the total resistance will decrease. With a decrease of total resistance, total amperage draw increases. The total resistance of a parallel circuit with two legs or two paths for current flow can be calculated by using this formula:

$$R_T = \frac{R_1 \times R_2}{R_1 + R_2}$$

If the value of  $R_1$  in Figure 2-23 was 3 ohms and  $R_2$  had a value of 6 ohms, the total resistance can be found.

$$R_T = \frac{R_1 \times R_2}{R_1 + R_2} \quad \text{or} \quad R_T = \frac{3 \times 6}{3 + 6} \quad \text{or} \quad R_T = \frac{18}{9} \quad R_T = 2$$

Based on this calculation, we can determine that the total circuit current is 6 amps (12 volts divided by 2 ohms). Using basic Ohm's law and a basic understanding of electricity, we can quickly determine other things about this circuit.

Each leg of the circuit has 12 volts applied to it; therefore, each leg must drop 12 volts. So the voltage drop across  $R_1$  is 12 volts, and the voltage drop across  $R_2$  is also 12 volts. Using the voltage drops, we can quickly find the current that flows through each leg. Since  $R_1$  has 3 ohms and drops 12 volts, the current through it must be 4 amps.  $R_2$  has 6 ohms and drops 12 volts and its current is 2 amps ( $I = E/R$ ). The total current flow through the circuit is 4 + 2 or 6 amps. To calculate current in a parallel circuit, each shunt branch is treated as an individual circuit. To determine the branch current, simply divide the source voltage by the shunt branch resistance:

$$I = E \div R$$

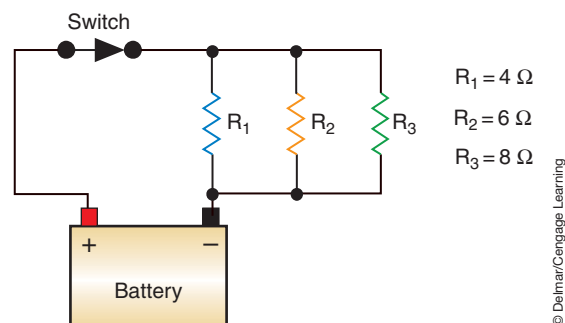
Referring to Figure 2-24, the total resistance of a circuit with more than two legs can be calculated with the following formula:

$$R_T = \frac{1}{\frac{1}{R_1} + \frac{1}{R_2} + \frac{1}{R_3} \dots \frac{1}{R_n}}$$

Using Figure 2-24 and its resistance values, total resistance would be calculated by:

$$R_T = \frac{1}{1/4 + 1/6 + 1/8}$$

This means total resistance is equal to the reciprocal of the sum of  $1/4 + 1/6 + 1/8$ . The next step is to add  $1/4 + 1/6 + 1/8$ . To do this, the least common denominator



**FIGURE 2-24** A parallel circuit with different resistances in each branch.

must be found. In this case, the least common denominator is 24 so the formula now looks like this:

$$\frac{1}{6/24 + 4/24 + 3/24}$$

Now the fractions can be added together (remember to add only the numerator):

$$\frac{1}{13/24}$$

Since we are working with reciprocals, the formula now looks like this:

$$1 \times \frac{24}{13} = 1.85 \Omega$$

Often it is much easier to calculate total resistance of a parallel circuit by using total current. Begin by finding the current through each leg of the parallel circuit; then add them together to find total current. Use basic Ohm's law to calculate the total resistance.

First, using the circuit illustrated in Figure 2-24, calculate the current through each branch:

1. Current through  $R_1 = E/R = 12/4 = 3$  amperes
2. Current through  $R_2 = E/R = 12/6 = 2$  amperes
3. Current through  $R_3 = E/R = 12/8 = 1.5$  amperes

Add all of the current flow through the branches together to get the total current flow:

$$\text{Total amperage} = 3 + 2 + 1.5 = 6.5 \text{ amperes}$$

Since this is a 12-volt system and total current is 6.5 amperes, total resistance is:

$$R = 12 \text{ volts}/6.5 \text{ amps} = 1.85 \Omega.$$

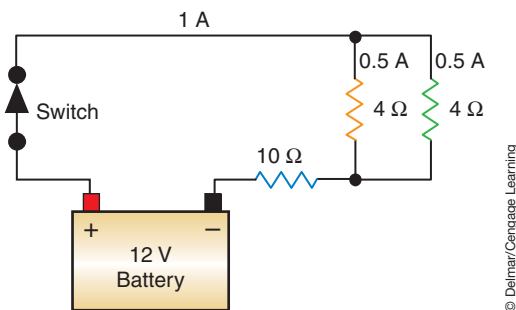
## Series-Parallel Circuits

The **series-parallel circuit** has some loads that are in series with each other and some that are in parallel (Figure 2-25). To calculate the total resistance in this type of circuit, calculate the **equivalent series loads** of the parallel branches first. Next, calculate the series resistance and add it to the equivalent series load. For example, if the parallel portion of the circuit has two branches with  $4 \Omega$  resistance each and the series portion has a single load of  $10 \Omega$ , use the following method to calculate the equivalent resistance of the parallel circuit:

$$R_T = \frac{R_1 \times R_2}{R_1 + R_2} \quad \text{or} \quad \frac{4 \times 4}{4 + 4} \quad \text{or} \quad \frac{16}{8} \quad \text{or} \quad 2 \text{ ohms}$$

Then add this equivalent resistance to the actual series resistance to find the total resistance of the circuit.

$$2 \text{ ohms} + 10 \text{ ohms} = 12 \text{ ohms}$$



**FIGURE 2-25** A series-parallel circuit with known resistance values.

The **equivalent series load**, or equivalent resistance, is the equivalent resistance of a parallel circuit plus the resistance in series and is equal to the resistance of a single load in series with the voltage source.

With the total resistance now known, total circuit current can be calculated. Because the source voltage is 12 volts, 12 is divided by 12 ohms.

$$I = E/R \quad \text{or} \quad I = 12/12 \quad \text{or} \quad I = 1 \text{ amp}$$

The current flow through each parallel leg is calculated by using the resistance of each leg and voltage drop across that leg. To do this, you must first find the voltage drops. Since all 12 volts are dropped by the circuit, we know that some are dropped by the parallel circuit and the rest by the resistor in series. We also know that the circuit current is 1 amp, the equivalent resistance value of the parallel circuit is 2 ohms, and the resistance of the series resistor is 10. Using Ohm's law we can calculate the voltage drop of the parallel circuit:

$$E = I \times R \quad \text{or} \quad E = 1 \times 2 \quad \text{or} \quad E = 2$$

Two volts are dropped by the parallel circuit. This means 2 volts are dropped by each of the 4-ohm resistors. Using our voltage drop, we can calculate our current flow through each parallel leg.

$$I = E/R \quad \text{or} \quad I = 2/4 \quad \text{or} \quad I = 0.5 \text{ amps}$$

Since the resistance on each leg is the same, each leg has 0.5 amps through it. If we did this right, the sum of the amperages will equal the current of the circuit. It does:  $0.5 + 0.5 = 1$ .

A slightly different series-parallel circuit is illustrated in Figure 2-26. In this circuit, a  $2 \Omega$  resistor is in series to a parallel circuit containing a  $6 \Omega$  and a  $3 \Omega$  resistor. To calculate total resistance, first find the resistance of the parallel portion of the circuit using  $(6 \times 3)/(6 + 3) = 18/9 = 2$  ohms of resistance. Add this amount to the series resistance;  $2 + 2 = 4$  ohms of total circuit resistance. Now total current can be calculated by  $I = E/R = 12/4 = 3$  amperes. This means that 3 amperes is flowing through the series portion of the circuit. To figure how much amperage is in each of the parallel branches, the amount of applied voltage to each branch must be calculated. Since the series circuit has 3 amperes going through a  $2 \Omega$  resistor, the voltage drop over this resistor can be figured using  $E = I \times R = 3 \times 2 = 6$  volts. Since the source voltage is 12 volts, this means that 6 volts are applied to each of the resistors in parallel ( $12 - 6 = 6$  volts) and that 6 volts are dropped over each of these resistors. Current through each branch can now be calculated:

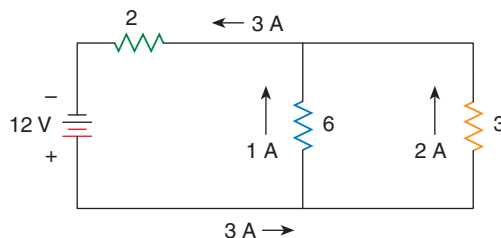
Current through the  $6 \Omega$  branch is  $I = E/R = 6/6 = 1$  ampere

Current through the  $3 \Omega$  branch is  $I = E/R = 6/3 = 2$  amperes

The sum of the current flow through the parallel branches should equal total current flow ( $1 + 2 = 3$  amperes).

Based on what was just covered, the characteristics of a series-parallel circuit can be summarized as follows:

1. Total resistance is the sum of the resistance value of the parallel portion and the series resistance.
2. Voltage drop over the parallel branch resistance is determined by the resistance value of the series resistor.



© Delmar/Cengage Learning

**FIGURE 2-26** In a series-parallel circuit, the sum of the currents through the legs will equal the current through the series portion of the circuit.

- 3. Total amperage is the sum of the current flow through each parallel branch.
- 4. The amperage through each parallel branch is determined by the resistance in the branch.

It is important to realize that the actual or measured values of current, voltage, and resistance may be somewhat different than the calculated values. The change is caused by the effects of heat on the resistances. As the voltage pushes current through a resistor, the resistor heats up. The resistor changes the electrical energy into heat energy. This heat may cause the resistance to increase or decrease depending on the material it is made of. The best example of a resistance changing electrical energy into heat energy is a light bulb. A light bulb gives off light because the conductor inside the bulb heats up and glows when current flows through it.

### Applying Ohm's Law

The primary importance of being able to apply Ohm's law is to predict what will happen if something else happens. Technicians use electrical meters to measure current, voltage, and resistance. When a measured value is not within specifications, you should be able to determine why. Ohm's law is used to do that.

Most automotive electrical systems are wired in parallel. Actually, the system is made up of a number of series circuits wired in parallel. This allows each electrical component to work independently of the others. When one component is turned on or off, the operation of the other components should not be affected.

Figure 2-27 illustrates a 12-volt circuit with one 3-ohm light bulb. The switch controls the operation of the light bulb. When the switch is closed, current flows and the bulb is lit. Four amps will flow through the circuit and the bulb.

$$I = E/R \quad \text{or} \quad I = 12/3 \quad \text{or} \quad I = 4 \text{ amps}$$

Figure 2-28 illustrates the same circuit with a 6-ohm light bulb added in parallel to the 3-ohm light bulb. With the switch for the new bulb closed, 2 amps will flow through that bulb. The 3-ohm bulb is still receiving 12 volts and has 4 amps flowing through it. It will operate in the same way and with the same brightness as it did before we added the 6-ohm light bulb. The only thing that changed was circuit current, which is now 6 (4 + 2) amps.

$$\text{Leg \#1} \quad I = E/R \quad \text{or} \quad I = 12/3 \quad \text{or} \quad I = 4 \text{ amps}$$

$$\text{Leg \#2} \quad I = E/R \quad \text{or} \quad I = 12/6 \quad \text{or} \quad I = 2 \text{ amps}$$

If the switch to the 3-ohm bulb is opened (Figure 2-29), the 6-ohm bulb works in the same way and with the same brightness as it did before we opened the switch. In this case, two things happened: the 3-ohm bulb no longer is lit and the total circuit current dropped to 2 amps.

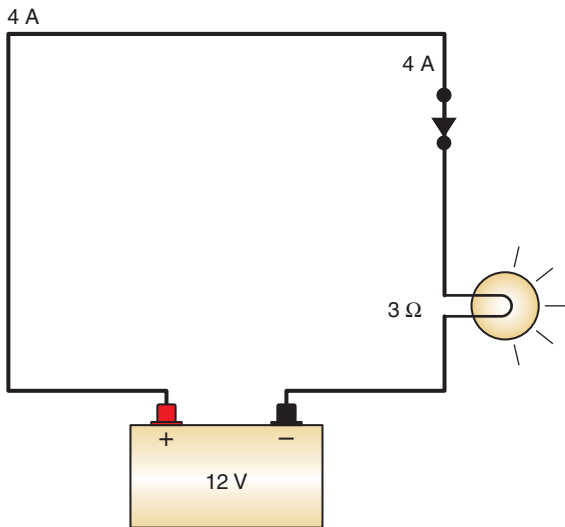


FIGURE 2-27 A simple light circuit.

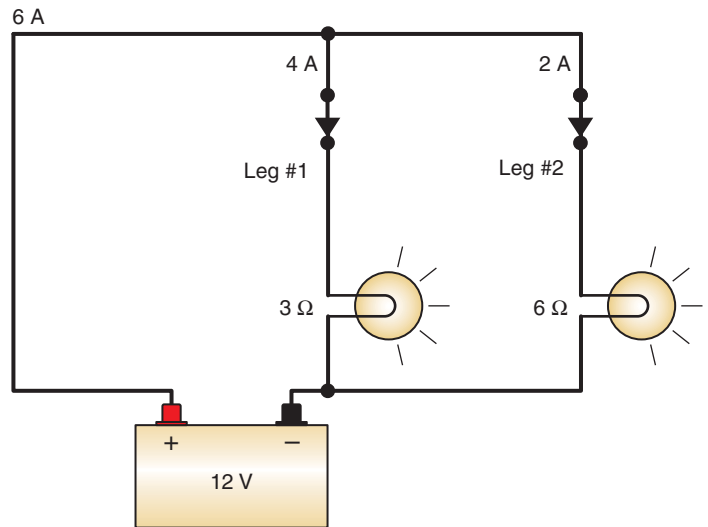
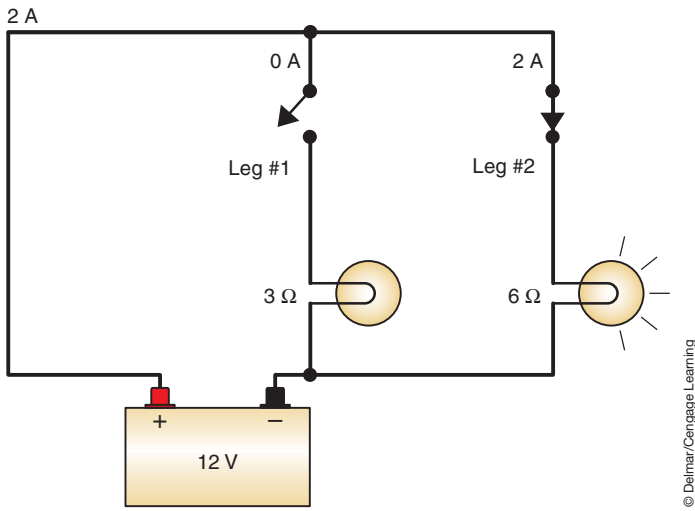
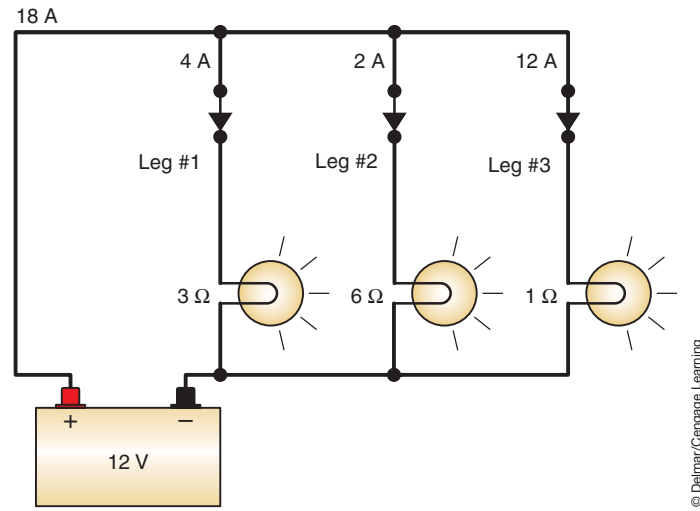


FIGURE 2-28 Two light bulbs wired in parallel.





**FIGURE 2-29** Two light bulbs wired in parallel; one switched on, the other switched off.



**FIGURE 2-30** Three light bulbs wired in parallel.

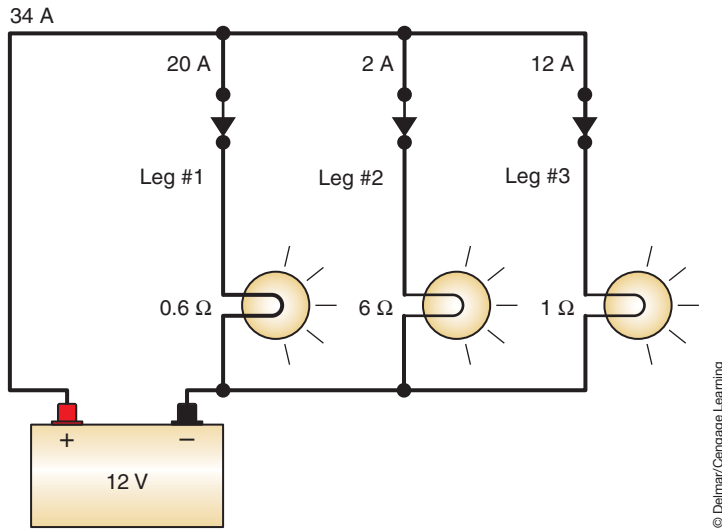
Figure 2-30 is the same circuit as Figure 2-29 except a 1-ohm light bulb and switch was added in parallel to the circuit. With the switch for the new bulb closed, 12 amps will flow through that circuit. The other bulbs are working in the same way and with the same brightness as before. Again, total circuit resistance decreases so the total circuit current increases. Total current is now 18 amps:

$$\begin{aligned}
 \text{Leg \#1} \quad I &= E/R \quad \text{or} \quad I = 12/3 \quad \text{or} \quad I = 4 \text{ amps} \\
 \text{Leg \#2} \quad I &= E/R \quad \text{or} \quad I = 12/6 \quad \text{or} \quad I = 2 \text{ amps} \\
 \text{Leg \#3} \quad I &= E/R \quad \text{or} \quad I = 12/1 \quad \text{or} \quad I = 12 \text{ amps} \\
 \text{Total current} &= 4 + 2 + 12 \text{ or } 18 \text{ amps}
 \end{aligned}$$

When the switch for any of these bulbs is opened or closed, the only things that happen are the bulbs either turn off or on and the total current through the circuit changes. Notice as we add more parallel legs, total circuit current goes up. There is a commonly used statement, “Current always takes the path of least resistance to ground.” This statement is not totally correct. If this were a true statement, then parallel circuits would not work. However, as illustrated in the previous circuits, current flows to all of the bulbs regardless of the bulb’s resistance. The resistances with lower values will draw higher currents, but all of the resistances will receive the current they allow. The statement should be, “Larger amounts of current will flow through lower resistances.” This is very important to remember when diagnosing electrical problems.

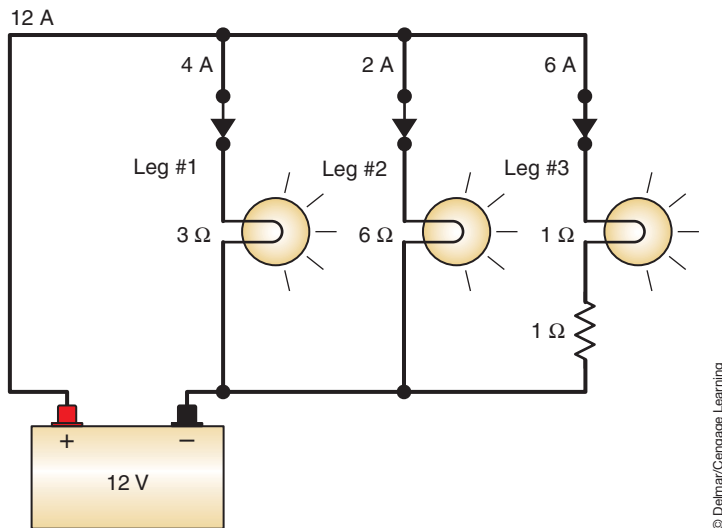
From Ohm’s law, we know that when resistance decreases, current increases. If we put a 0.6-ohm light bulb in place of the 3-ohm bulb (Figure 2-31), the other bulbs will work in the same way and with the same intensity as they did before. However, 20 amps of current will flow through the 0.6-ohm bulb. This will raise total circuit current to 34 amps. Lowering the resistance on the one leg of the parallel circuit greatly increases the current through the circuit. This high current may damage the circuit or components. It is possible that high current can cause wires to burn. In this case, the wires that would burn are the wires that would carry the 34 amps or the 20 amps to the bulb, not the wires to the other bulbs.

$$\begin{aligned}
 \text{Leg \#1} \quad I &= E/R \quad \text{or} \quad I = 12/0.6 \quad \text{or} \quad I = 20 \text{ amps} \\
 \text{Leg \#2} \quad I &= E/R \quad \text{or} \quad I = 12/6 \quad \text{or} \quad I = 2 \text{ amps} \\
 \text{Leg \#3} \quad I &= E/R \quad \text{or} \quad I = 12/1 \quad \text{or} \quad I = 12 \text{ amps} \\
 \text{Total current} &= 20 + 2 + 12 \text{ or } 34 \text{ amps}
 \end{aligned}$$



**FIGURE 2-31** Parallel light circuit.

Let's see what happens when we add resistance to one of the parallel legs. An increase in resistance should cause a decrease in current. In Figure 2-32, a 1-ohm resistor was added after the 1-ohm light bulb. This resistor is in series with the light bulb and the total resistance of that leg is now 2 ohms. The current through that leg is now 6 amps. Again, the other bulbs were not affected by the change. The only change to the whole circuit was in total circuit current, which now drops to 12 amps. The added resistance lowered total circuit current and changed the way the 1-ohm bulb works. This bulb will now drop only 6 volts. The remaining 6 volts will be dropped by the added resistor. The 1-ohm bulb will be much dimmer than before; its power rating dropped from 144 watts to 36 watts. Additional resistance causes the bulb to be dimmer. The bulb itself wasn't changed, only the resistance of that leg changed. The dimness is caused by the circuit, not the bulb.



**FIGURE 2-32** A parallel light circuit with one leg having a series resistance added.

*This page intentionally left blank*

## KIRCHHOFF'S LAWS

Ohm's law is stated as it takes one volt to push one ampere through one ohm of resistance. Ohm's law is the principle law of electricity and is used to determine electrical values. However, there are times when Ohm's law would be difficult to use in determining electrical values. This is true in circuits that do not have clearly defined series or parallel connections. Also, Ohm's law can be difficult to use if the circuit has more than one power source. In these instances, Kirchhoff's laws is used.

Kirchhoff stated two laws that described voltage and current relationships in an electric circuit. The first law, known as **Kirchhoff's voltage law**, states that the algebraic sum of the voltage sources and voltage drops in a closed circuit must equal zero. This law is actually the rule that states that the sum of the voltage drops in a series circuit must equal the source voltage.

The second law, known as **Kirchhoff's current law**, states that the algebraic sum of the currents entering and leaving a point must equal zero. This is the rule that states that total current flow in a parallel circuit will be the sum of the currents through all the circuit branches.

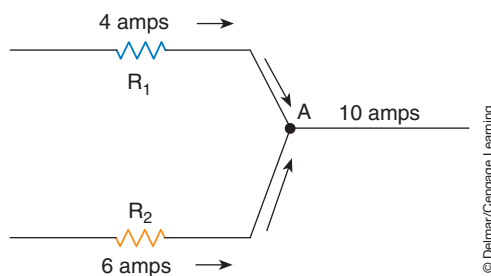
### Kirchhoff's Current Law

The concept of Kirchhoff's current law is the fact that if more current entered a particular point than left that point, a charge would have to develop at that point. In the parallel circuit illustrated (Figure 2-34), if four amperes of current flow through  $R_1$  to the junction at point A, and 6 amperes of current flow through  $R_2$  to point A, then the sum of the two currents is 10 amperes leaving point A. Since Kirchhoff's current law states that the algebraic sum of the currents must equal zero, to use this law the current entering a point is considered to be positive and the current leaving a point is considered to be negative. Since the current flowing through  $R_1$  and  $R_2$  are entering point A, they are considered positive. The current leaving point A is considered negative. In this example then:

$$+4 \text{ A} + 6 \text{ A} - 10 \text{ A} = 0 \text{ A}$$

**AUTHOR'S NOTE:** The figures used in the following explanation will have a source voltage of 120 volts. This amount is used so the example will be easier to understand and to keep the values high enough to prevent having to use fractions.

Figure 2-35 illustrates a more complex series-parallel circuit. Ohm's law tells us that this circuit will have a total of 2 amperes flowing through it since there is a total of 60 ohms of resistance. Since 2 amperes are flowing through  $R_1$ , 32 volts will be dropped and the applied voltage at point B will be 88 volts. With 2 amperes flowing through  $R_3$ , the voltage drop over this resistor will be 40 volts. With 88 volts applied to point B and  $R_3$  dropping 40 volts that leaves 48 volts to be dropped over  $R_2$  and the parallel circuit of  $R_4$  through  $R_6$ . This means that points B to E will have a current of 0.8 amperes and the parallel branch will have 1.2 amperes.



**FIGURE 2-34** The sum of the currents entering and leaving a point in the circuit must equal zero.

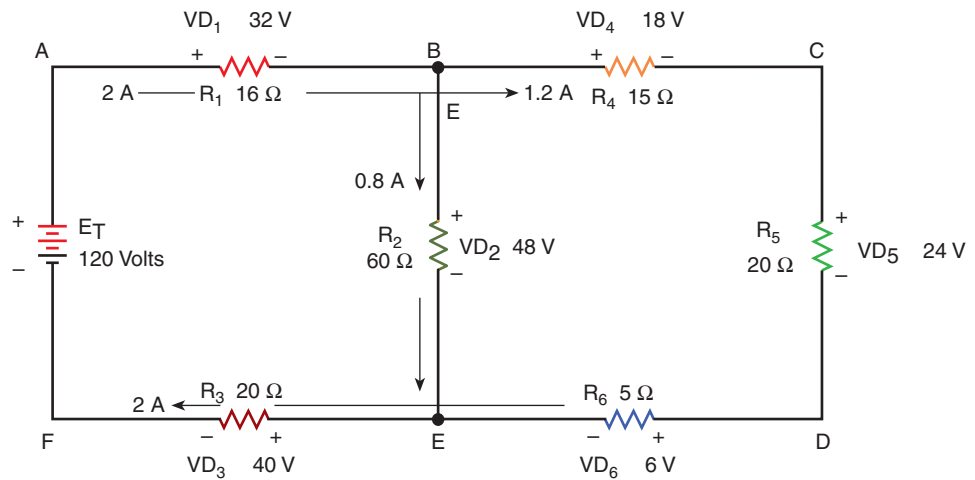


FIGURE 2-35 Illustration of use of Krichhoff's laws.

Notice what occurs in the current at point B. Two amperes is flowing into point B from  $R_1$ . At this point, the current splits with part flowing to  $R_2$  and part to the circuit containing resistors  $R_4$  through  $R_6$ . The current entering point B is considered positive, and the two currents leaving point B are considered negative. The equation would look like:

$$+2\text{ A} - 0.8\text{ A} - 1.2\text{ A} = 0\text{ A}$$

At point E, there is 0.8 ampere of current entering from the circuit with resistor  $R_2$  and 1.2 amperes of current entering from the circuit with resistors  $R_4$  through  $R_6$ . Two amperes of current leaves point E and flows through  $R_3$ .

$$+0.8\text{ A} + 1.2\text{ A} - 2\text{ A} = 0\text{ A}$$

## Kirchhoff's Voltage Law

Kirchhoff's voltage law states that the algebraic sum of the voltages around any closed loop must equal zero. To be able to calculate the sum, first it must be established which end of the resistive element is positive and which is negative. Referring back to Figure 2-35, we will use the conventional current flow of positive to negative. Therefore, the point at which current enters a resistor is marked positive, and the point where current leaves the resistor is marked negative.

**AUTHOR'S NOTE:** It does not matter if you use the conventional theory of current flow or the electron theory; you only need to be consistent. The sum of voltage drops will be the same regardless which current flow assumption you use.

The circuit illustrated in Figure 2-35 has three separate closed loops. Closed loop ACDF contains the voltage drops  $VD_1$ ,  $VD_4$ ,  $VD_5$ ,  $VD_6$ ,  $VD_3$ , and  $E_T$ .  $E_T$  is the source and must be included in the equation. The voltage drops for this loop are as follows:

$$+VD_1 + VD_4 + VD_5 + VD_6 + VD_3 - E_T = 0$$

$$+32\text{ V} + 18\text{ V} + 24\text{ V} + 6\text{ V} + 40\text{ V} - 120\text{ V} = 0\text{ V}$$

The positive or negative sign for each number is determined by the assumed direction of current flow. In this example, it is assumed that current leaves point A and returns to point A. Current leaving point A enters  $R_1$  at the positive side. Therefore, the voltage is considered to be positive (+32 V). The same is true for  $R_4$ ,  $R_5$ ,  $R_6$ , and  $R_3$ . However, the current enters the voltage source at the negative side so  $E_T$  is assumed to be negative.

Closed loop ABEF contains voltage drops  $VD_1$ ,  $VD_2$ ,  $VD_3$ , and  $E_T$ . Current will leave point A and return to point A through  $R_1$ ,  $R_2$ ,  $R_3$ , and the voltage source. The voltage drops are as follows:

$$+VD_1 + VD_2 + VD_3 - VD_T = 0$$

$$+32\text{ V} + 48\text{ V} + 40\text{ V} - 120\text{ V} = 0\text{ V}$$

Closed loop BCDE contains voltage drops  $VD_4$ ,  $VD_5$ ,  $VD_6$ , and  $VD_2$ . Current leaves point B and returns to point B, flowing through  $R_4$ ,  $R_5$ ,  $R_6$ , and  $R_2$ .

$$+VD_4 + VD_5 + VD_6 - VD_2 = 0$$

$$+18\text{ V} + 24\text{ V} + 6\text{ V} - 48\text{ V} = 0\text{ V}$$

## CAPACITANCE

Some automotive electrical systems will use a capacitor or condenser to store electrical charges (Figure 2-36). A capacitor uses the theory of **capacitance** to temporarily store electrical energy. Capacitance ( $C$ ) is the ability of two conducting surfaces to store voltage. The two surfaces must be separated by an insulator.

A **capacitor** does not consume any power however, it will store and release electrical energy. All of the voltage stored in the capacitor is returned to the circuit when the capacitor discharges. Because the capacitor stores voltage, it will also absorb voltage changes in the circuit. By providing for this storage of voltage, damaging voltage spikes can be controlled. They are also used to reduce radio noise.

A capacitor is made by wrapping two conductor strips around an insulating strip. The insulating strip, or **dielectric**, prevents the plates from coming in contact while keeping them very close to each other. The dielectric can be made of insulator material such as ceramic, glass, paper, plastic, or even the air between the two plates. A capacitor blocks direct current. A small amount of current enters the capacitor and charges it.

Most capacitors are connected in parallel across the circuit (Figure 2-37). Capacitors operate on the principle that opposite charges attract each other and that there is a potential voltage between any two oppositely charged points. When the switch is closed, the protons at the positive battery terminal will attract some of the electrons on one plate of the capacitor away from the area near the dielectric material. As a result, the atoms of the **positive plate** are unbalanced because there are more protons than electrons in the atom. This plate now has a positive charge because of the shortage of electrons (Figure 2-38). The positive charge of this plate will attract electrons on the other plate. The dielectric keeps the electrons on the negative plate from crossing over to the positive plate, resulting in a storage of electrons on

The insulator in a capacitor is called a **dielectric**. The dielectric can be made of some insulator material such as ceramic, glass, paper, plastic, or even the air between the two plates.

The plate connected to the positive battery terminal is the **positive plate**.



FIGURE 2-36 Capacitors that can be used in automotive electrical circuits.

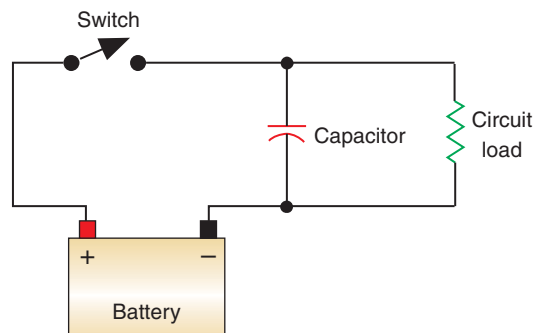


FIGURE 2-37 A capacitor connected to a circuit.



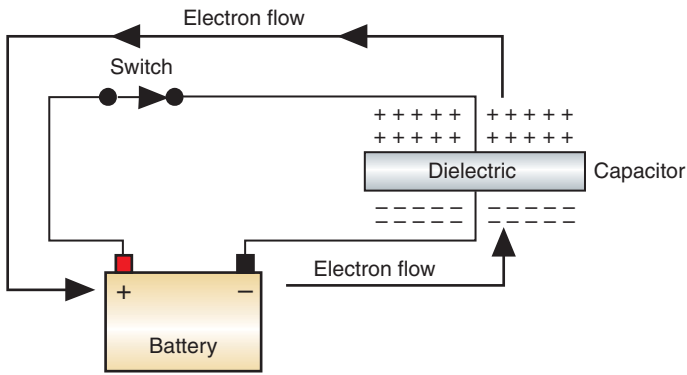


FIGURE 2-38 The positive plate sheds its electrons.

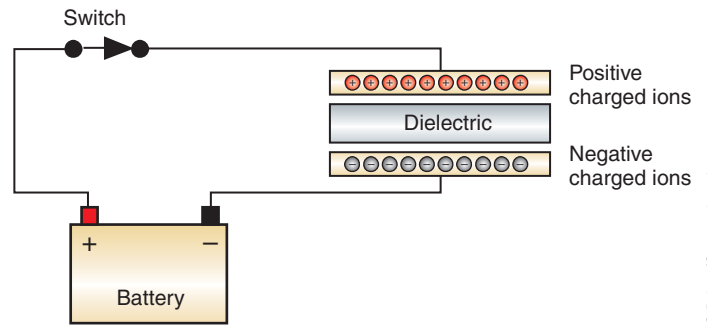


FIGURE 2-39 The electrons will be stored on the negative plate.

An atom that has fewer electrons than protons is said to be a positive ion.

The field that is between the two oppositely charged plates is called the **electrostatic field**.

**Static electricity** is electricity that is not in motion.

the negative plate (Figure 2-39). The movement of electrons to the negative plate and away from the positive plate is an electrical current.

Current will flow “through” the capacitor until the voltage charges across the capacitor and across the battery are equalized. Current flow through a capacitor is only the effect of the electron movement onto the negative plate and away from the positive plate. Electrons do not actually pass through the capacitor from one plate to another. The charges on the plates do not move through the **electrostatic field**. They are stored on the plates as **static electricity**.

When the charges across the capacitor and battery are equalized, there is no potential difference and no more current will flow “through” the capacitor (Figure 2-40). Current will now flow through the load components in the circuit (Figure 2-41).

When the switch is opened, current flow from the battery through the resistor is stopped. However, the capacitor has a storage of electrons on its negative plate. Because the negative plate of the capacitor is connected to the positive plate through the resistor, the capacitor acts as the source. The capacitor will discharge the electrons through the resistor until the atoms of the positive plate and negative plate return to a balanced state (Figure 2-42).

In the event that a high-voltage spike occurs in the circuit, the capacitor will absorb the additional voltage before it is able to damage the circuit components. A capacitor can also be used to stop current flow quickly when a circuit is opened (such as in the ignition system). It can also store a high-voltage charge and then discharge it when a circuit needs the voltage (such as in some air bag systems).

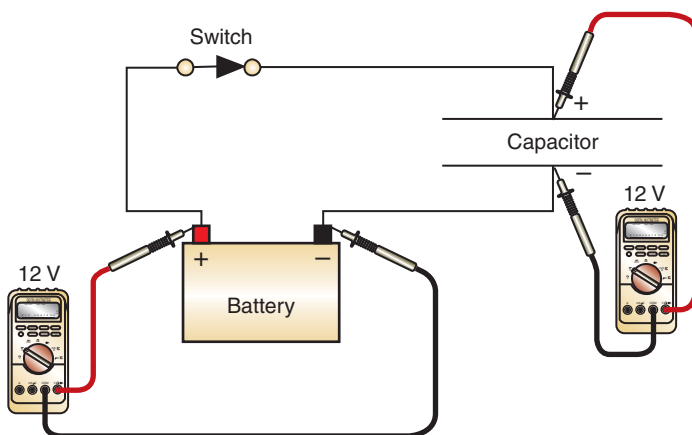


FIGURE 2-40 A capacitor when it is fully charged.

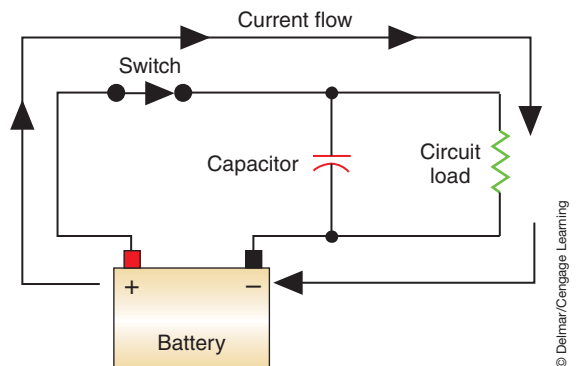
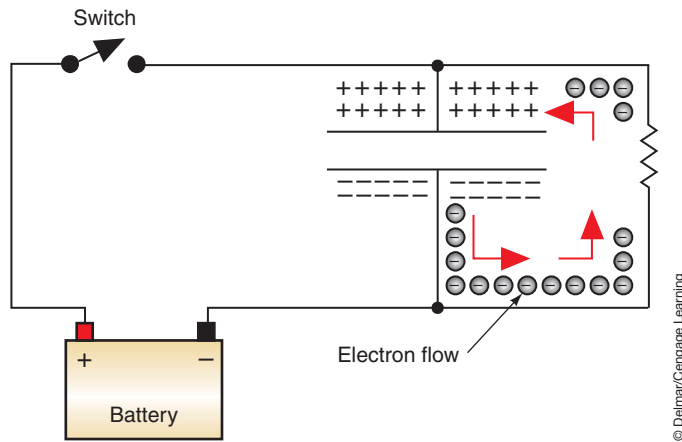


FIGURE 2-41 Current flow with a fully charged capacitor.



**FIGURE 2-42** Current flow with the switch open and the capacitor discharging.

Capacitors are rated in units called farads. A one-farad capacitor connected to a one-volt source will store  $6.28 \times 10^{18}$  electrons. A farad is a large unit and most commonly used capacitors are rated in picofarad (a trillionth of a farad) or microfarads (a millionth of a farad). In addition, the capacitor has a voltage rating that is determined by how much voltage can be applied to it without the dielectric breaking down. The maximum voltage rating and capacitance determine the amount of energy a capacitor holds. The voltage rating is related to the strength and thickness of the dielectric. The voltage rating increases with increasing dielectric strength and the thickness of the dielectric. The capacitance increases with the area of the plates and decreases with the thickness of the dielectric.

## MAGNETISM PRINCIPLES

Magnetism is a force that is used to produce most of the electrical power in the world. It is also the force used to create the electricity to recharge a vehicle's battery, make a starter work, and produce signals for various operating systems. A magnet is a material that attracts iron, steel, and a few other materials. Because magnetism is closely related to electricity, many of the laws that govern electricity also govern magnetism.

There are two types of magnets used on automobiles, permanent magnets and electromagnets. Permanent magnets are magnets that do not require any force or power to keep their magnetic field. Electromagnets depend on electrical current flow to produce and, in most cases, keep their magnetic field.

### Magnets

All magnets have polarity. A magnet that is allowed to hang free will align itself north and south. The end facing north is called the north-seeking pole and the end facing south is called the south-seeking pole. Like poles will repel each other and unlike poles will attract each other. These principles are shown in Figure 2-43. The magnetic attraction is the strongest at the poles.

**Magnetic flux density** is a concentration of the lines of force (Figure 2-44). A strong magnet produces many lines of force and a weak magnet produces fewer lines of force. Invisible lines of force leave the magnet at the north pole and enter again at the south pole. While inside the magnet, the lines of force travel from the south pole to the north pole (Figure 2-45).

The field of force (or magnetic field) is all the space, outside the magnet, that contains lines of magnetic force. Magnetic lines of force penetrate all substances; there is no known insulation against magnetic lines of force. The lines of force may be deflected only by other magnetic materials or by another magnetic field.



### A BIT OF HISTORY

The force of a magnet was first discovered over 2,000 years ago by the Greeks. They noticed that a type of stone, now called magnetite, was attracted to iron. During the Dark Ages, people believed evil spirits caused the strange powers of magnetite.

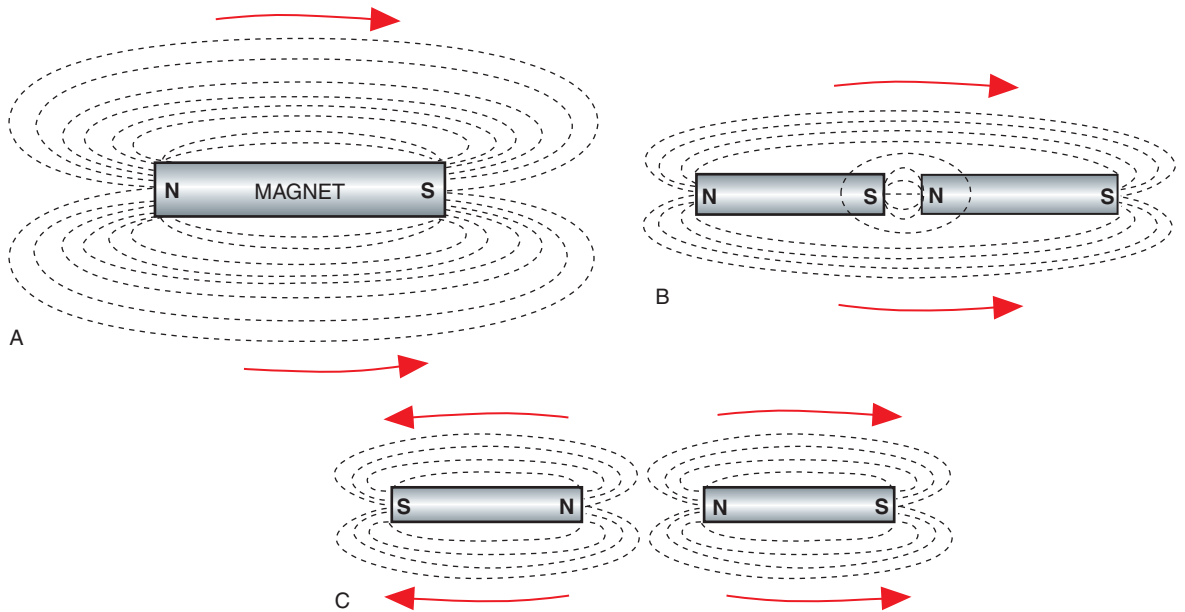


FIGURE 2-43 Magnetic principles: (A) All magnets have poles, (B) unlike poles attract each other, and (C) like poles repel.

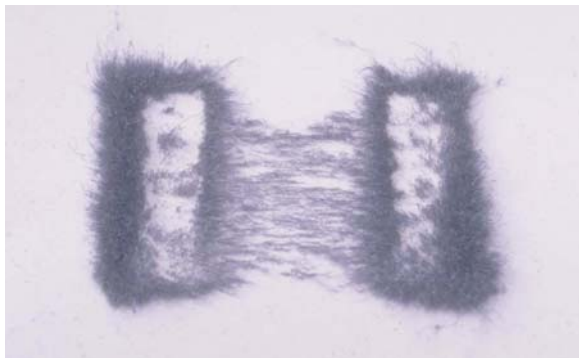


FIGURE 2-44 Iron filings indicate the lines of magnetic flux.

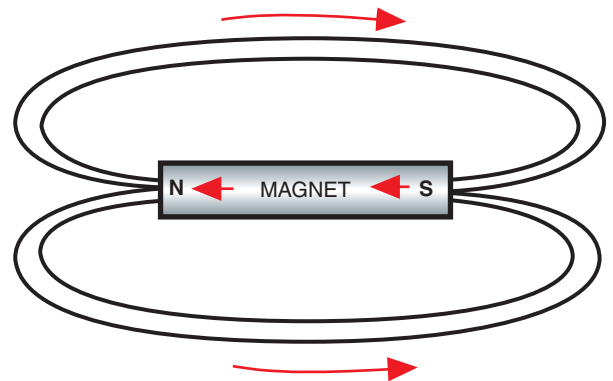


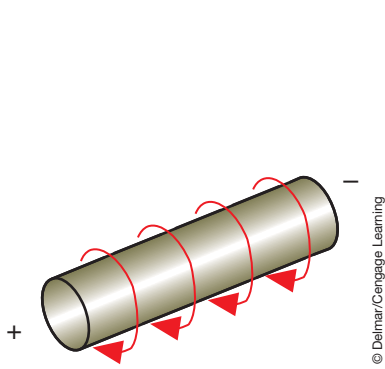
FIGURE 2-45 Lines of force through the magnet.

## Electromagnetism

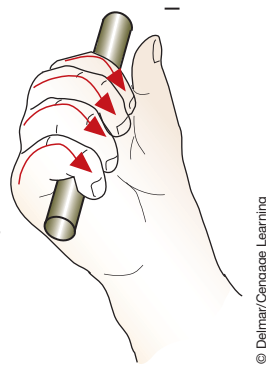
**Electromagnetism** uses the theory that whenever an electrical current flows through a conductor, a magnetic field is formed around the conductor (Figure 2-46). The number of lines of force and the strength of the magnetic field produced will be in direct proportion to the amount of current flow.

The direction of the lines of force is determined by the **right-hand rule**. Using the conventional theory of current flow being from positive to negative, the right hand is used to grasp the wire, with the thumb pointing in the direction of current flow. The fingers will point in the direction of the magnetic lines of force (Figure 2-47).

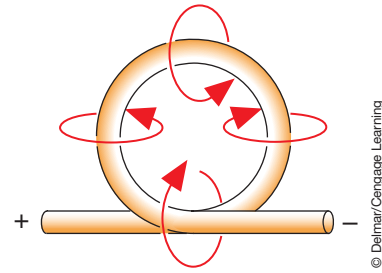
André Marie Ampère noted that current flowing in the same direction through two nearby wires will cause the wires to attract one another. Also, he observed that if current flow in one of the wires is reversed, the wires will repel one another. In addition, he found that if a wire is coiled with current flowing through the wire, the same magnetic field that surrounds a straight wire combines to form one larger magnetic field. This magnetic field has true north and south poles (Figure 2-48). Looping the wire doubles the flux density where the wire is running parallel to itself. The illustration (Figure 2-49) shows how these lines of force will join and add to each other.



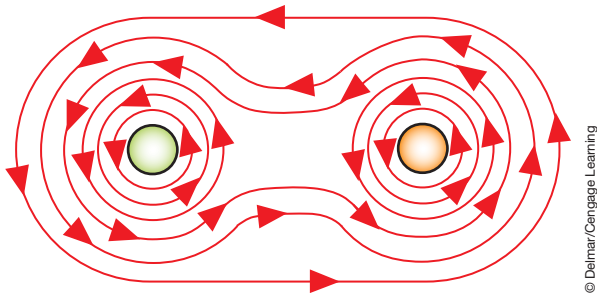
**FIGURE 2-46** A magnetic field surrounds a conductor that has current flowing through it.



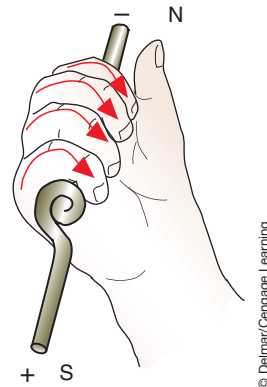
**FIGURE 2-47** Right-hand rule to determine direction of magnetic lines of force.



**FIGURE 2-48** Looping the conductor increases the magnetic field.



**FIGURE 2-49** Lines of force join together and attract each other.



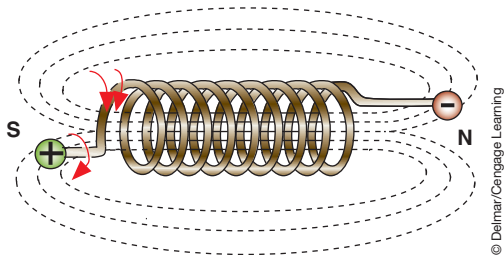
**FIGURE 2-50** Right-hand rule to determine magnetic poles.

The north pole can be determined in the coil by use of the right-hand rule. Grasp the coil with the fingers pointing in the direction of current flow (+ to -) and the thumb will point toward the north pole (Figure 2-50).

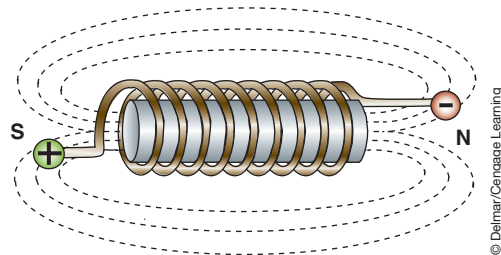
As more loops are added, the fields from each loop will join and increase the flux density (Figure 2-51). To make the magnetic field even stronger, an iron core can be placed in the center of the coil (Figure 2-52). The soft iron core has high **permeability** and low **reluctance**, which provides an excellent conductor for the magnetic field to travel through the center of the wire coil.

The strength of an electromagnetic coil is affected by the following factors:

1. The amount of current flowing through the wire.
2. The number of windings or turns.



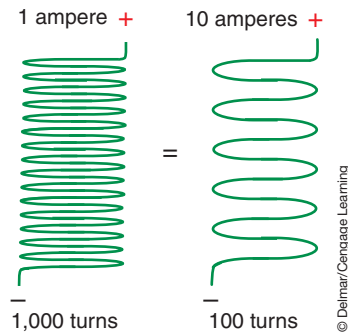
**FIGURE 2-51** Adding more loops of wire increases the magnetic flux density.



**FIGURE 2-52** The addition of an iron core concentrates the flux density.

**Permeability** is the term used to indicate the magnetic conductivity of a substance compared with the conductivity of air. The greater the permeability, the greater the magnetic conductivity and the easier a substance can be magnetized or the more attracted it is to a magnet.

**Reluctance** is the term used to indicate a material's resistance to the passage of flux lines. Highly reluctant materials are not attracted to magnets.



**FIGURE 2-53** Magnetic field strength is determined by the amount of amperage and the number of coils.

3. The size, length, and type of core material.
4. The direction and angle at which the lines of force are cut.

The strength of the magnetic field is measured in ampere-turns:

$$\text{ampere-turns} = \text{amperes} \times \text{number of turns}$$

The magnetic field strength is measured by multiplying the current flow in amperes through a coil by the number of complete turns of wire in the coil. For example, in the illustration (Figure 2-53), a 1,000-turn coil with 1 ampere of current would have a field strength of 1,000 ampere-turns. This coil would have the same field strength as a coil with 100 turns and 10 amperes of current.

## THEORY OF INDUCTION

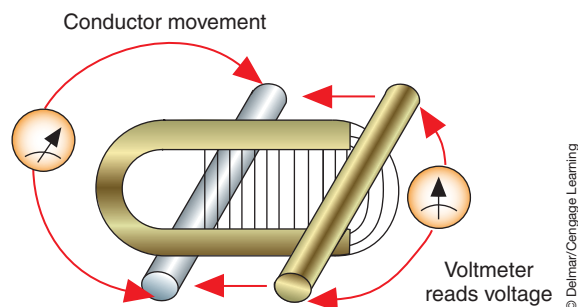
Electricity can be produced by magnetic **induction**. Magnetic induction occurs when a conductor is moved through the magnetic lines of force (Figure 2-54) or when a magnetic field is moved across a conductor. A difference of potential is set up between the ends of the conductor and a voltage is induced. This voltage exists only when the magnetic field or the conductor is in motion.

The induced voltage can be increased by either increasing the speed in which the magnetic lines of force cut the conductor or by increasing the number of conductors that are cut. It is this principle that is behind the operation of all ignition systems, starter motors, and charging systems.

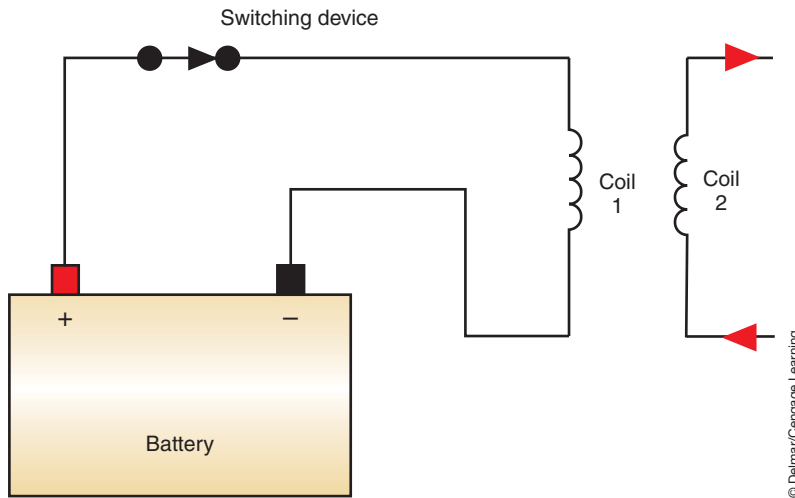
A common induction device is the ignition coil. As the current increases, the coil will reach a point of **saturation**. This is the point at which the magnetic strength eventually levels off and where current will no longer increase as it passes through the coil. The magnetic lines of force, which represent stored energy, will collapse when the applied voltage is removed. When the lines of force collapse, the magnetic energy is returned to the wire as electrical energy.

**Mutual induction** is used in ignition coils where a rapidly changing magnetic field in the primary windings creates a voltage in the secondary winding (Figure 2-55).

A desirable induction is called a **mutual induction**.



**FIGURE 2-54** Moving a conductor through a magnetic field induces an electrical potential difference.



**FIGURE 2-55** A mutual induction is used to create an electrical current in coil 2 if the current flow in coil 1 is turned off.

If voltage is induced in the wires of a coil when current is first connected or disconnected, it is called self-induction. The resulting current is in the opposite direction of the applied current and tends to reduce the magnetic force. **Self-induction** is governed by Lenz's law, which states:

An induced current flows in a direction opposite the magnetic field that produced it.

Self-induction is generally not wanted in automotive circuits. For example, when a switch is opened, self-induction tends to continue to supply current in the same direction as the original current because as the magnetic field collapses, it induces voltage in the wire. According to Lenz's law, voltage induced in a conductor tends to oppose a change in current flow. Self-induction can cause an electrical arc to occur across an opened switch. The arcing may momentarily bypass the switch and allow the circuit that was turned off to operate for a short period of time. The arcing will also burn the contacts of the switch.

Self-induction is commonly found in electrical components that contain a coil or an electric motor. To help reduce the arc across contacts, a capacitor or clamping diode may be connected to the circuit. The capacitor will absorb the high-voltage arcs and prevent arcing across the contacts. Diodes are semiconductors that allow current flow in only one direction. A clamping diode can be connected in parallel to the coil and will prevent current flow from the self-induction coil to the switch.

Magnetic induction is also the basis for a generator and many of the sensors on today's vehicles. In a generator, a magnetic field rotates inside a set of conductors. As the magnetic field crosses the wires, a voltage is induced. The amount of voltage induced by this action depends on the speed of the rotating field, the strength of the field, and the number of conductors the field cuts through. This principle will be discussed in greater detail in Chapter 7.

Magnetic sensors are used to measure speeds, such as engine, vehicle, and shaft speeds. These sensors typically use a permanent magnet. Rotational speed is determined by the passing of blades or teeth in and out of the magnetic field. As a tooth moves in and out of the magnetic field, the strength of the magnetic field is changed and a voltage signal is induced. This signal is sent to a control device, where it is interpreted. This principle is discussed in greater detail in Chapter 12.

## EMI SUPPRESSION

**Electromagnetic interference (EMI)** is an undesirable creation of electromagnetism whenever current is switched on and off. As manufacturers began to increase the number of electronic components and systems in their vehicles, the problem of EMI had to be controlled. The low-power integrated circuits used on modern vehicles are sensitive to the signals produced

**Self-induction** is also referred to as counter EMF (CEMF) or as a voltage spike.



## TERMS TO KNOW

Alternating current  
Ampere  
Atom  
Balanced  
Balanced atom  
Capacitance  
Capacitor  
Circuit  
Closed circuit  
Conductor  
Conventional theory  
Current  
Cycle  
Dielectric  
Direct current (DC)  
Electromagnetic interference (EMI)  
Electromagnetism  
Electromotive force (EMF)  
Electron theory  
Electrons  
Electrostatic field  
Equivalent series load  
Ground  
Induction  
Insulator  
Ion  
Kirchhoff's voltage law  
Kirchhoff's current law  
Magnetic flux density  
Mutual induction  
Neutrons  
Nucleus  
Ohms  
Ohm's law  
Open circuit  
Parallel circuit  
Permeability  
Positive plate  
Power  
Protons  
Reluctance  
Resistance

as a result of EMI. EMI is produced as current in a conductor is turned on and off. EMI is also caused by static electricity that is created by friction. The friction is a result of tires contacting the road, or of fan belts contacting the pulleys.

EMI can disrupt the vehicle's computer systems by inducing false messages to the computer. The computer requires messages to be sent over circuits in order to communicate with other computers, sensors, and actuators. If any of these signals are disrupted, the engine and/or accessories may turn off.

### EMI can be suppressed by any one of the following methods:

1. Adding a resistance to the conductors. This is usually done to high-voltage systems, such as the secondary circuit of the ignition system.
2. Connecting a capacitor in parallel and a choke coil in series with the circuit.
3. Shielding the conductor or load components with a metal or metal-impregnated plastic.
4. Increasing the number of paths to ground by using designated ground circuits. This provides a clear path to ground that is very low in resistance.
5. Adding a clamping diode in parallel to the component.
6. Adding an isolation diode in series to the component.

## SUMMARY

---

- An atom is constructed of a complex arrangement of electrons in orbit around a nucleus. If the number of electrons and protons are equal, the atom is balanced or neutral.
- A conductor allows electricity to easily flow through it.
- An insulator does not allow electricity to easily flow through it.
- Electricity is the movement of electrons from atom to atom. In order for the electrons to move in the same direction, an electromotive force (EMF) must be applied to the circuit.
- The electron theory defines electron flow as motion from negative to positive.
- The conventional theory of current flow states that current flows from a positive point to a less positive point.
- Voltage is defined as an electrical pressure and is the difference between the positive and negative charges.
- Current is defined as the rate of electron flow and is measured in amperes. Amperage is the amount of electrons passing any given point in the circuit in one second.
- Resistance is defined as opposition to current flow and is measured in ohms ( $\Omega$ ).
- Ohm's law defines the relationship between current, voltage, and resistance. It is the basic law of electricity and states that the amount of current in an electric circuit is inversely proportional to the resistance of the circuit and is directly proportional to the voltage in the circuit.
- Wattage represents the measure of power (P) used in a circuit. Wattage is measured by using Watt's law formula, which defines the relationship between amperage, voltage, and wattage.
- Capacitance is the ability of two conducting surfaces to store voltage.
- Direct current results from a constant voltage and a current that flows in one direction.
- In an alternating-current circuit, voltage and current do not remain constant. AC current changes direction from positive to negative and negative to positive.
- For current to flow, the electrons must have a complete path from the source voltage to the load component and back to the source.
- The series circuit provides a single path for current flow from the electrical source through all the circuit's components and back to the source.

- A parallel circuit provides two or more paths for current to flow.
- A series-parallel circuit is a combination of the series and parallel circuits.
- The equivalent series load is the total resistance of a parallel circuit plus the resistance of the load in series with the voltage source.
- Voltage drop is caused by a resistance in the circuit that reduces the electrical pressure available after the resistance.
- Kirchhoff's voltage law states that the algebraic sum of the voltage sources and voltage drops in a closed circuit must equal zero. This law is actually the rule that states that the sum of the voltage drops in a series circuit must equal the source voltage.
- Kirchhoff's current law states that the algebraic sum of the currents entering and leaving a point must equal zero. This is the rule that states that total flow of current in a parallel circuit will be the sum of the currents through all the circuit branches.

## TERMS TO KNOW

(continued)

Right-hand rule

Saturation

Self-induction

Semiconductors

Series circuit

Series-parallel circuit

Shell

Static electricity

Valence ring

Voltage

Watts

## REVIEW QUESTIONS

### Short-Answer Essays

1. List and define the three elements of electricity.
2. Explain the basic principles of Ohm's law.
3. List and describe the three types of circuits.
4. Explain the principle of electromagnetism.
5. Describe the principle of induction.
6. Describe the basics of electron flow.
7. Define the two types of electrical current.
8. Describe the difference between insulators, conductors, and semiconductors.
9. Explain the basic concepts of capacitance.
10. What does the measurement of "watt" represent?

### Fill in the Blanks

1. \_\_\_\_\_ are negatively charged particles. The nucleus contains positively charged particles called \_\_\_\_\_ and particles that have no charge called \_\_\_\_\_.
2. A \_\_\_\_\_ allows electricity to easily flow through it. An \_\_\_\_\_ does not allow electricity to easily flow through it.
3. For the electrons to move in the same direction, there must be an \_\_\_\_\_ applied.
4. The \_\_\_\_\_ of current flow states that current flows from a positive point to a less positive point.
5. Resistance is defined as \_\_\_\_\_ to current flow and is measured in \_\_\_\_\_.
6. \_\_\_\_\_ is the ability of two conducting surfaces to store voltage.
7. Kirchhoff's voltage law states that the \_\_\_\_\_ in an electrical circuit will always \_\_\_\_\_ available voltage at the source.
8. The \_\_\_\_\_ of all the resistors in series is the total resistance of that series circuit.
9. \_\_\_\_\_ is defined as an electrical pressure.
10. \_\_\_\_\_ is defined as the rate of electron flow.

## MULTIPLE CHOICE

1. Which of the following methods can be used to form an electrical current?
  - A. Magnetic induction.
  - B. Chemical reaction.
  - C. Heat.
  - D. All of the above.
  - E. None of the above.
2. In a series circuit:
  - A. Total resistance is the sum of all of the resistances in the circuit.
  - B. Total resistance is less than the lowest resistor.
  - C. Amperage will increase as more resistance is added.
  - D. All of the above.

3. All of the following concerning voltage drop are true EXCEPT:
- All of the voltage from the source must be dropped before it returns to the source.
  - Corrosion is not a contributor to voltage drop.
  - Voltage drop is the conversion of electrical energy into another energy form.
  - Voltage drop can be measured with a voltmeter.
4. All of the following concerning voltage are true EXCEPT:
- Voltage is the electrical pressure that causes electrons to move.
  - Voltage will exist between any two points in a circuit unless the potential drops to zero.
  - Voltage is  $A \times R$ .
  - In a series circuit, voltage is the same at all points in the circuit.
5. Wattage is:
- A measure of the total electrical work being performed per unit of time.
  - Expressed as  $P = R \times A$ .
  - Both A and B.
  - Neither A nor B.
6. A capacitor:
- Consumes electrical power.
  - Induces voltage.
  - Both A and B.
  - Neither A nor B.
7. Which statement about electrical currents is correct?
- Alternating current can be stored in a battery.
  - Alternating current is produced from a voltage and current that remain constant and flow in the same direction.
  - Direct current is used for most electrical systems on the automobile.
  - Direct current changes directions from positive to negative.
8. Induction:
- Is the magnetic process of producing a current flow in a wire without any actual contact to the wire.
  - Exists when the magnetic field or the conductor is in motion.
  - All of the above.
  - None of the above.
9. All of the following statements are true EXCEPT:
- If the resistance increases and the voltage remains constant, the amperage will increase.
  - Ohm's law can be stated as  $A = V \div R$ .
  - If voltage is increased, amperage will increase.
  - An open circuit does not allow current flow.
10. Which of the following statements is correct?
- An insulator is capable of supporting the flow of electricity through it.
  - A conductor is not capable of supporting the flow of electricity.
  - All of the above.
  - None of the above.

## Chapter 3

# ELECTRICAL AND ELECTRONIC COMPONENTS

### UPON COMPLETION AND REVIEW OF THIS CHAPTER, YOU SHOULD BE ABLE TO:

- Describe the common types of electrical system components used and how they affect the electrical system.
- Explain the operation of the electrical controls, including switches, relays, and variable resistors.
- Describe the basic operating principles of electronic components.
- Explain the use of electronic components in the circuit.
- Explain the purpose of circuit protection devices. Describe the most common types in use.
- Define circuit defects, including opens, shorts, grounds, and excessive resistance.
- Explain the effects that each type of circuit defect has on the operation of the electrical system.

### INTRODUCTION

In this chapter you will be introduced to electrical and electronic components. These components include circuit protection devices, switches, relays, variable resistors, diodes, and different forms of transistors. Today's technician must comprehend the operation of these components and the ways they affect electrical system operation. With this knowledge, the technician will be able to accurately and quickly diagnose many electrical failures.

To be able to properly diagnose the components and circuits, the technician must be able to use the test equipment that is designed for electrical system diagnosis. In this chapter you will learn about the various types of test equipment used for diagnosing electrical systems. You will learn the appropriate equipment to use to locate the fault based on the symptoms. In addition, the various types of defects that cause the system to operate improperly are discussed.

### ELECTRICAL COMPONENTS

Electrical circuits require different components depending on the type of work they do and how they are to perform it. A light may be wired directly to the battery, but it will remain on until the battery drains. A switch will provide for control of the light circuit. However, if variable dimming of the light is required, a rheostat is also needed.

There are several electrical components that may be incorporated into a circuit to achieve the desired results from the system. These components include switches, relays, buzzers, and various types of resistors.

The term **pole** refers to the number of input circuits.

The term **throw** refers to the number of output circuits.

## Switches

A switch is the most common means of providing control of electrical current flow to an accessory (Figure 3-1). A switch can control the on/off operation of a circuit or direct the flow of current through various circuits. The contacts inside the switch assembly carry the current when they are closed. When they are open, current flow is stopped.

A **normally open (NO)** switch will not allow current flow when it is in its rest position. The contacts are open until they are acted on by an outside force that closes them to complete the circuit. A **normally closed (NC)** switch will allow current flow when it is in its rest position. The contacts are closed until they are acted on by an outside force that opens them to stop current flow.

The simplest type of switch is the single-**pole**, single-**throw** (SPST) switch (Figure 3-2). This switch controls the on/off operation of a single circuit. The most common type of SPST switch design is the hinged pawl. The pawl acts as the contact and changes position as directed to open or close the circuit.

Some SPST switches are designed to be a momentary contact switch. This switch usually has a spring that holds the contacts open until an outside force is applied and closes them. The horn button on most vehicles is of this design.

Some electrical systems may require the use of a single-pole, double-throw switch (SPDT). The dimmer switch used in the headlight system is usually an SPDT switch. This switch has one input circuit with two output circuits. Depending on the position of the contacts, voltage is applied to the high-beam circuit or to the low-beam circuit (Figure 3-3).

One of the most complex switches is the **ganged switch**. This type of switch is commonly used as an ignition switch. In Figure 3-4, the five wipers are all ganged together and will move



FIGURE 3-1 Common types of switches used in the automotive electrical system.

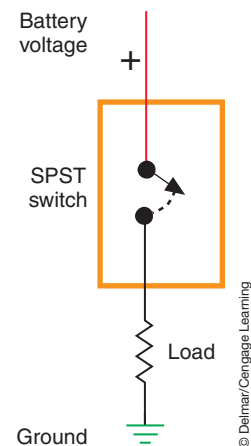


FIGURE 3-2 A simplified illustration of an SPST switch.

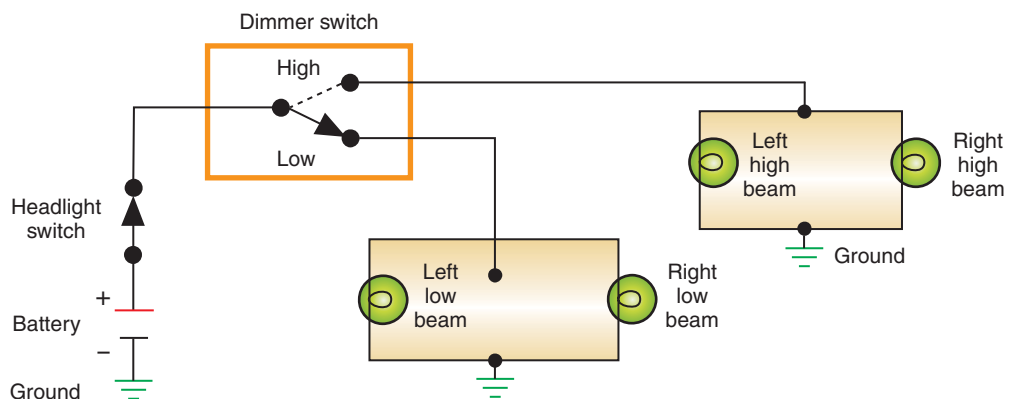
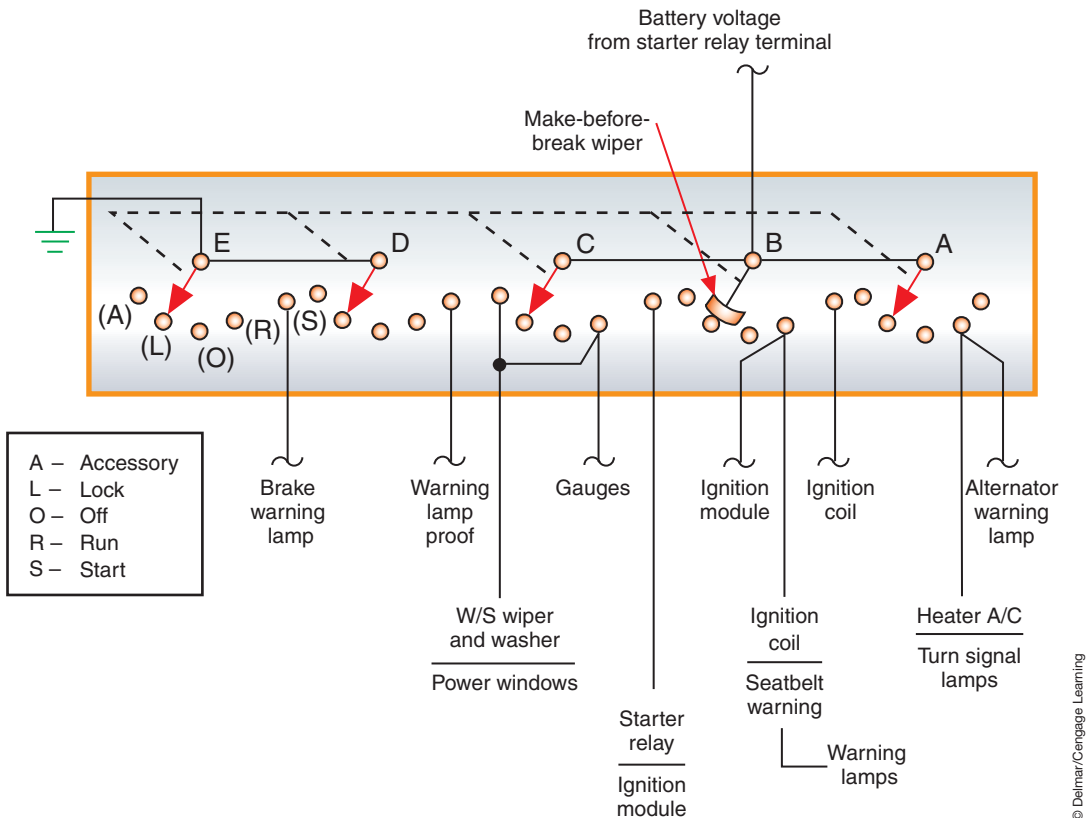


FIGURE 3-3 A simplified schematic of a headlight system using an SPDT dimmer switch.



**FIGURE 3-4** Illustration of an ignition switch.

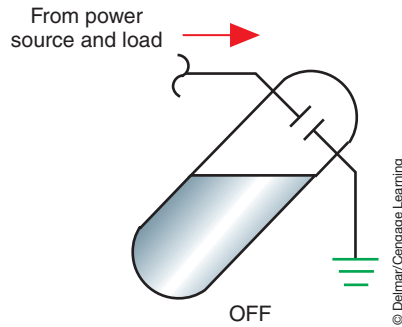
together. Battery voltage is applied to the switch from the starter relay terminal. When the ignition key is turned to the START position, all wipers move to the “S” position. Wipers D and E will complete the circuit to ground to test the instrument panel warning lamps. Wiper B provides battery voltage to the ignition coil. Wiper C supplies battery voltage to the starter relay and the ignition module. Wiper A has no output.

**AUTHOR’S NOTE:** The dotted lines used in the switch symbol indicate that the wipers of the switch move together.

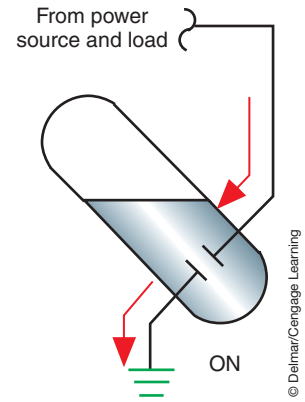
Once the engine starts, the wipers are moved to the RUN position. Wipers D and E are moved out of contact with any output terminals. Wiper A supplies battery voltage to the comfort controls and turn signals, wiper B supplies battery voltage to the ignition coil and other accessories, and wiper C supplies battery voltage to other accessories. The jumper wire between terminals A and R of wiper C indicate that those accessories listed can be operated with the ignition switch in the RUN or ACC position.

Mercury switches are used by many vehicle manufacturers to detect motion. This switch uses a capsule that is partially filled with mercury and has two electrical contacts located at one end. If the switch is constructed as a normally open switch, the contacts are located above the mercury level (Figure 3-5). Mercury is an excellent conductor of electricity. If the capsule is moved so the mercury touches both of the electrical contacts, the circuit is completed (Figure 3-6). This type of switch is used to illuminate the engine compartment when the hood is opened. While the hood is shut, the capsule is tilted in a position such that the mercury is not able to complete the circuit. Once the hood is opened, the capsule tilts with the hood, the mercury completes the circuit, and the light turns on.





**FIGURE 3-5** A mercury switch in the open position. The mercury is not covering the points.

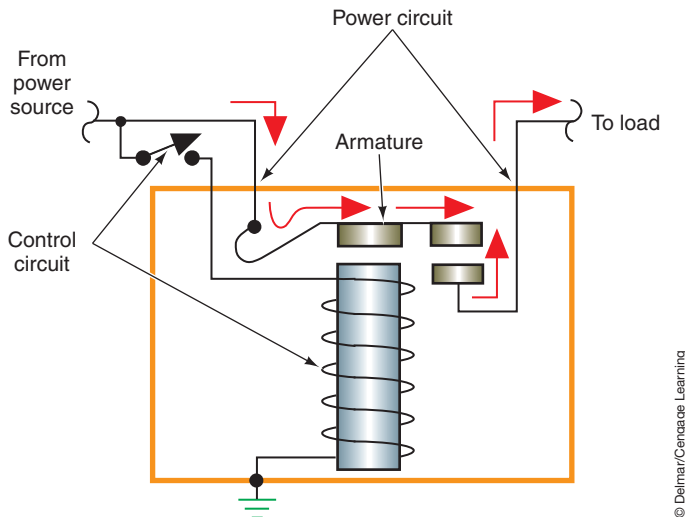


**FIGURE 3-6** When the mercury switch is tilted, the mercury covers the points and closes the circuit.

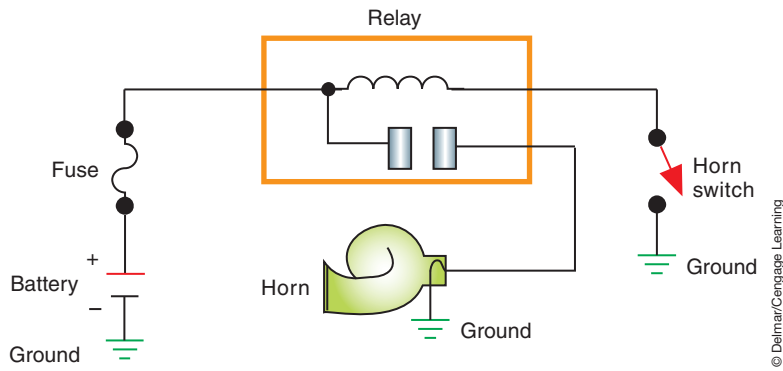
## Relays

Some circuits utilize electromagnetic switches called **relays** (Figure 3-7). The coil in the relay has a very high resistance, thus it will draw very low current. This low current is used to produce a magnetic field that will close the contacts. Normally open relays have their points closed by the electromagnetic field, and normally closed relays have their points opened by the magnetic field. The contacts are designed to carry the high current required to operate the load component. When current is applied to the coil, the contacts close and heavy battery current flows to the load component that is being controlled.

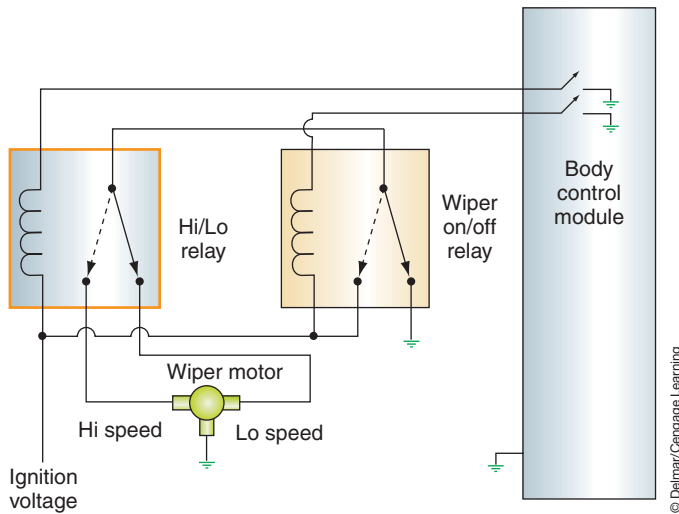
The illustration (Figure 3-8) shows a relay application in a horn circuit. Battery voltage is applied to the coil. Because the horn button is a normally open-type switch, the current flow to ground is open. Pushing the horn button will complete the circuit, allowing current flow through the coil. The coil develops a magnetic field, which closes the contacts. With the contacts closed, battery voltage is applied to the horn (which is grounded). Used in this manner, the horn relay becomes a control of the high current necessary to blow the horn. The control circuit may be wired with very thin wire because it will have low current flowing through it. The control unit may have only 0.25 ampere flowing through it, and the horn may require 24 or more amperes.



**FIGURE 3-7** A relay uses electrical current to create a magnetic field to draw the contact point closed.



**FIGURE 3-8** A relay can be used in the horn circuit to reduce the required size of the conductors installed in the steering column.



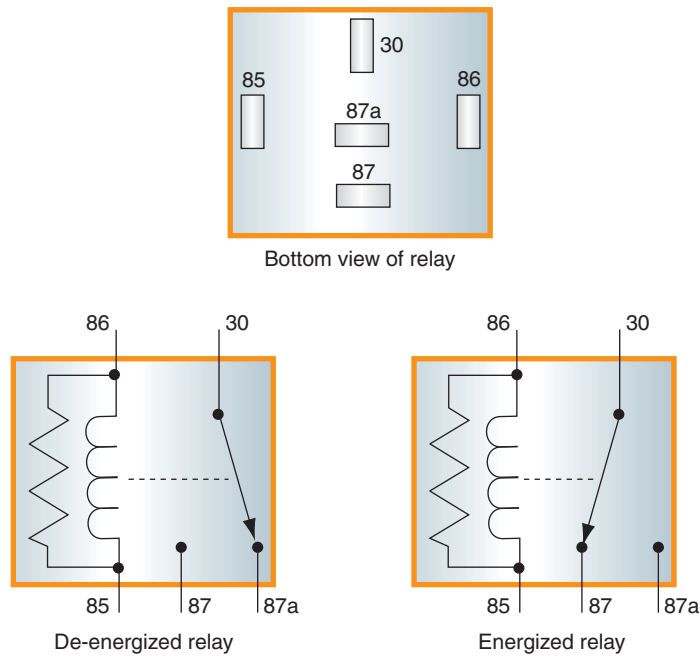
**FIGURE 3-9** Using a relay as a diverter to control Hi/Lo wiper operation. The Hi/Lo relay diverts current to the different brushes of the wiper motor.

Relays can also be used as a circuit diverter (Figure 3-9). In this example, the Hi/Lo wiper relay will direct current flow to either the high-speed brush or low-speed brush of the wiper motor to control wiper speeds.

**ISO Relays.** ISO relays conform to the specifications of the International Standards Organization (ISO) for common size and terminal patterns (Figure 3-10). The terminals are identified as 30, 87a, 87, 86, and 85. Terminal 30 is usually connected to battery voltage. This source voltage can be either switched (on or off by some type of switch) or connected directly to the battery. Terminal 87a is connected to terminal 30 when the relay is de-energized. Terminal 87 is connected to terminal 30 when the relay is energized. Terminal 86 is connected to battery voltage (switched or un-switched) to supply current to the electromagnet. Finally, terminal 85 provides ground for the electromagnet. Once again, the ground can be switched or unswitched.

## Solenoids

A **solenoid** is an electromagnetic device and operates in the same way as a relay; however, a solenoid uses a movable iron core. Solenoids can do mechanical work, such as switching electrical, vacuum, and liquid circuits. The iron core inside the coil of the solenoid is spring loaded. When current flows through the coil, the magnetic field created around the coil attracts the



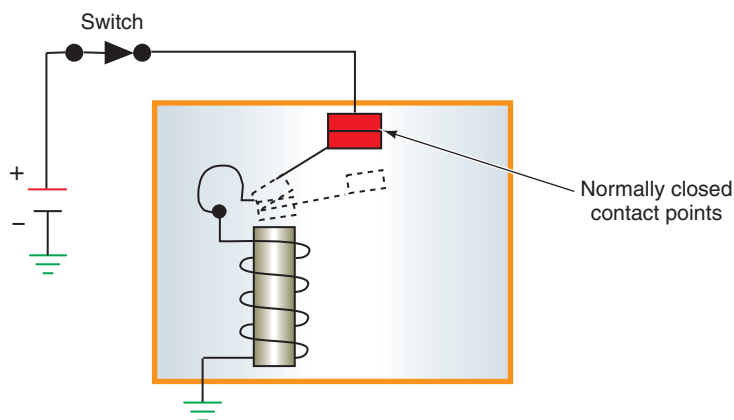
© Delmar/Cengage Learning

**FIGURE 3-10** ISO relay terminal identification.

core and moves it into the coil. To do work, the core is attached to a mechanical linkage, which causes something to move. When current flow through the coil stops, the spring pushes the core back to its original position. Some power door locks use solenoids to work the locking devices. Solenoids may also switch a circuit on or off, in addition to causing a mechanical action. Such is the case with some starter solenoids. These devices move the starter gear in and out of mesh with the flywheel. At the same time, they complete the circuit from the battery to the ignition circuit. Both of these actions are necessary to start an engine.

## Buzzers

A **buzzer**, or **sound generator**, is sometimes used to warn the driver of possible safety hazards by emitting an audio signal (such as when the seat belt is not buckled). A buzzer is similar in construction to a relay except for the internal wiring (Figure 3-11). The coil is supplied current through the normally closed contact points. When voltage is applied to the buzzer, current flows through the contact points to the coil. When the coil is energized, the contact



© Delmar/Cengage Learning

**FIGURE 3-11** A buzzer reacts to the current flow to open and close rapidly, creating a noise.

arm is attracted to the magnetic field. As soon as the contact arm is pulled down, the current flow to the coil is opened, and the magnetic field is dissipated. The contact arm then closes again, and the circuit to the coil is closed. This opening and closing action occurs very rapidly. It is this movement that generates the vibrating signal.

## Resistors

All circuits require resistance in order to operate. If the resistance performs a useful function, it is referred to as the **load device**. However, resistance can also be used to control current flow and as sensing devices for computer systems. There are several types of resistors that may be used within a circuit. These include fixed resistors, stepped resistors, and variable resistors.

**Fixed Resistors.** Fixed resistors are usually made of carbon or oxidized metal (Figure 3-12). These resistors have a set resistance value and are used to limit the amount of current flow in a circuit. The resistance value can be determined by the color bands on the protective shell (Figure 3-13). Usually there are four or five color bands. When there are four bands, the first two are the digit bands, the third is the “multiplier,” and the fourth is the tolerance. On a resistor with five bands, the first three are digit bands.

For example, if the resistor has four color bands of yellow, black, brown, and gold, the resistance value is determined as follows:

The first color band (yellow) gives the first digit value of 4.

The second color band (black) gives the second digit value of 0.

The digit value is now 40. Multiply this by the value of the third band. In this case, brown has a value of 10 so the resistor should have 400 ohms of resistance ( $40 \times 10 = 400$ ).

The last band gives the tolerance. Gold equals a tolerance range of  $\pm 5\%$ .

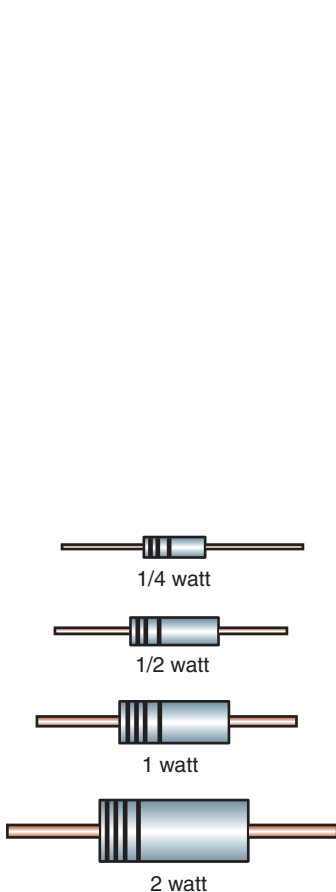
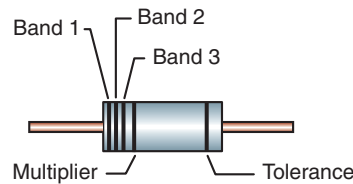


FIGURE 3-12 Fixed resistors.

© Delmar/Cengage Learning

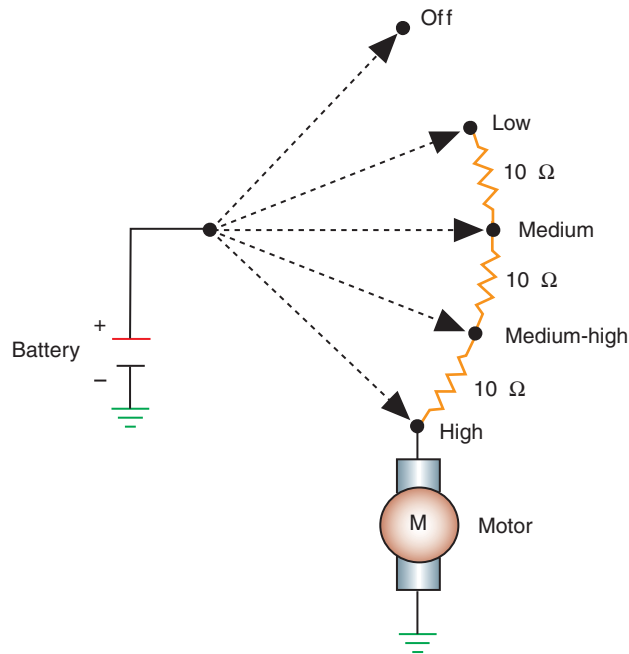


Band 1 1st digit		Band 2 2nd digit		Band 3 (If used) 3rd digit	
Color	Digit	Color	Digit	Color	Digit
Black	0	Black	0	Black	0
Brown	1	Brown	1	Brown	1
Red	2	Red	2	Red	2
Orange	3	Orange	3	Orange	3
Yellow	4	Yellow	4	Yellow	4
Green	5	Green	5	Green	5
Blue	6	Blue	6	Blue	6
Violet	7	Violet	7	Violet	7
Gray	8	Gray	8	Gray	8
White	9	White	9	White	9

Multiplier		Resistance Tolerance	
Color	Multiplier	Color	Tolerance
Black	1	Silver	$\pm 10\%$
Brown	10	Gold	$\pm 5\%$
Red	100	Brown	$\pm 1\%$
Orange	1,000		
Yellow	10,000		
Green	100,000		
Blue	1,000,000		
Silver	0.01		
Gold	0.1		

FIGURE 3-13 Resistor color code chart.

© Delmar/Cengage Learning



**FIGURE 3-14** A stepped resistor is commonly used to control motor speeds. The total resistance of the switch is 30 Ω in the low position, 20 Ω in the medium position, 10 Ω in the medium-high position, and 0 Ω in the high position.

© Delmar/Cengage Learning

**Shop Manual**

Chapter 3, page 111

**Stepped Resistors.** A **stepped resistor** has two or more fixed resistor values. The stepped resistor can have an integral switch or have a switch wired in series. A stepped resistor is commonly used to control electrical motor speeds (Figure 3-14). By changing the position of the switch, resistance is increased or decreased within the circuit. If the current flows through a low resistance, then higher current flows to the motor and its speed is increased. If the switch is placed in the low-speed position, additional resistance is added to the circuit. Less current flows to the motor, which causes it to operate at a reduced speed.

A stepped resistor is also used to convert digital to analog signals in a computer circuit. This is accomplished by converting the on/off digital signals into a continuously variable analog signal.

**Shop Manual**

Chapter 3, page 112

**Variable Resistors.** **Variable resistors** provide for an infinite number of resistance values within a range. The most common types of variable resistors are rheostats and potentiometers. A **rheostat** is a two-terminal variable resistor used to regulate the strength of an electrical current. A rheostat has one terminal connected to the fixed end of a resistor and a second terminal connected to a moveable contact called a **wiper** (Figure 3-15). By changing the position of the wiper on the resistor, the amount of resistance can be increased or decreased. The most common use of the rheostat is in the instrument panel lighting switch. As the switch knob is turned, the instrument lights dim or brighten depending on the resistance value.

A **potentiometer** is a three-wire variable resistor that acts as a voltage divider to produce a continuously variable output signal proportional to a mechanical position. When a potentiometer is installed into a circuit, one terminal is connected to a power source at one end of the resistor. The second wire is connected to the opposite end of the resistor and is the ground return path. The third wire is connected to the wiper contact (Figure 3-16). The wiper senses a variable voltage drop as it is moved over the resistor. Because the current always flows through the same amount of resistance, the total voltage drop measured by the potentiometer is very stable. For this reason, the potentiometer is a common type of input sensor for the vehicle's onboard computers.

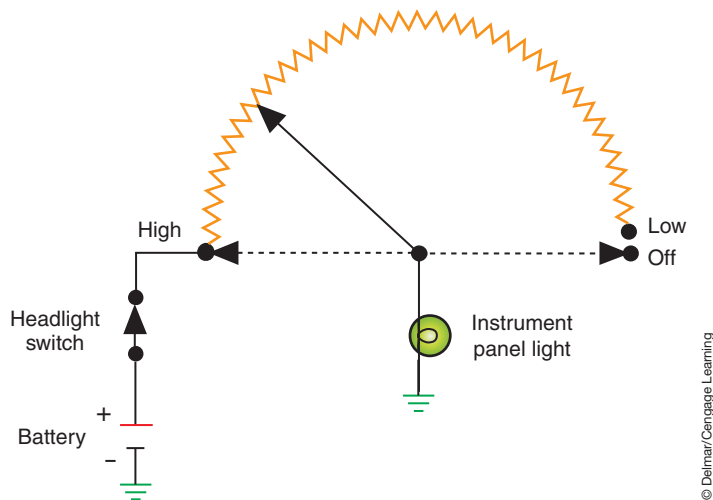


FIGURE 3-15 A rheostat can be used to control the brightness of a lamp.

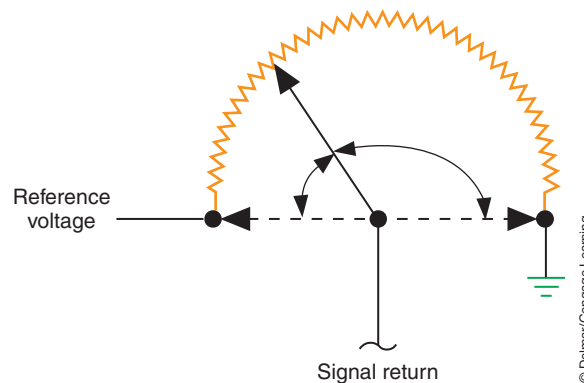


FIGURE 3-16 A potentiometer is used to send a signal voltage from the wiper.

## ELECTRONIC COMPONENTS

Because a semiconductor material can operate as both a conductor and an insulator, it is very useful as a switching device. How a semiconductor material works depends on the way current flows, or tries to flow, through it.

As discussed in Chapter 2, electrical materials are classified as conductors, insulators, or semiconductors. Semiconductors include diodes, transistors, and silicon-controlled rectifiers. These semiconductors are often called solid-state devices because they are constructed of a solid material. The most common materials used in the construction of semiconductors are silicon or germanium. Both of these materials are classified as a **crystal**, since they have a definite atom structure.

Silicon and germanium have four electrons in their outer orbits. Because of their crystal-type structure, each atom shares an electron with four other atoms (Figure 3-17). As a result of this **covalent bonding**, each atom will have eight electrons in its outer orbit. All the orbits

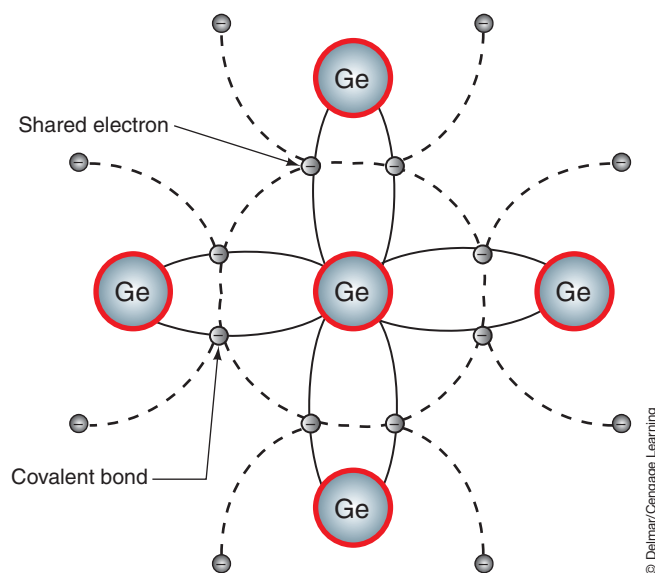
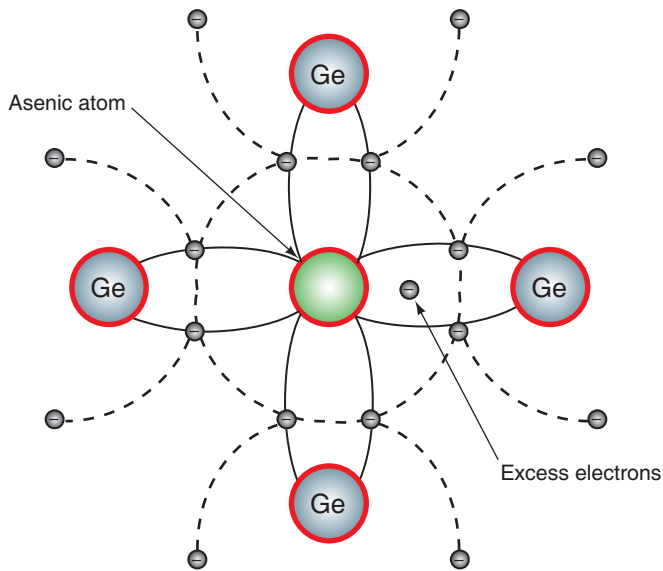


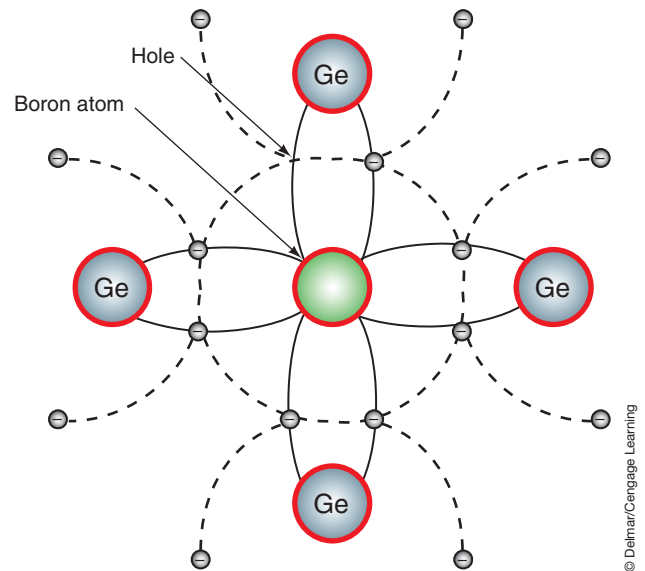
FIGURE 3-17 Crystal structure of germanium.





**FIGURE 3-18** Germanium crystal doped with an arsenic atom to produce an N-type material.

© Delmar/Cengage Learning



**FIGURE 3-19** Germanium crystal doped with a boron atom to produce a P-type material.

© Delmar/Cengage Learning

are filled and there are no free electrons, thus the material (as a category of matter) falls somewhere between conductor and insulator.

Perfect crystals are not used for manufacturing semiconductors. They are doped with impurity atoms. This doping adds a small percentage of another element to the crystal. The doping element can be arsenic, antimony, phosphorous, boron, aluminum, or gallium.

If the crystal is doped by using arsenic, antimony, or phosphorous, the result is a material with free electrons (Figure 3-18). Materials such as arsenic have five electrons, which leaves one electron left over. This doped material becomes negatively charged and is referred to as an **N-type material**. Under the influence of an EMF, it will support current flow.

If boron, aluminum, or gallium are added to the crystal, a P-type material is produced. Materials like boron have three electrons in their outermost orbit. Because there is one fewer electron, there is an absence of an electron that produces a **hole** (Figure 3-19) and becomes positively charged.

By putting N-type and P-type materials together in a certain order, solid-state components are built that can be used for switching devices, voltage regulators, electrical control, and so on.

## Diodes

A **diode** is an electrical one-way check valve that will allow current to flow in one direction only. A diode is the simplest semiconductor device. It is formed by joining P-type semiconductor material with N-type material. The N (negative) side of a diode is called the **cathode** and the P (positive) side, the **anode** (Figure 3-20). The point where the cathode and anode join together is called the PN junction. The outer shell of the diode will have a stripe painted around it. This stripe designates which end of the diode is the cathode.

When a diode is made, the positive holes from the P region and the negative charges from the N region are drawn toward the junction. Some charges cross over and combine with opposite charges from the other side. When the charges cross over, the two halves are no longer balanced and the diode builds up a network of internal charges opposite to the charges at the PN junction. The internal EMF between the opposite charges limits the further diffusion of charges across the junction.

When the diode is incorporated within a circuit and a voltage is applied, the internal characteristics change. If the diode is forward biased, there will be current flow (Figure 3-21).

### Shop Manual

Chapter 3, page 113

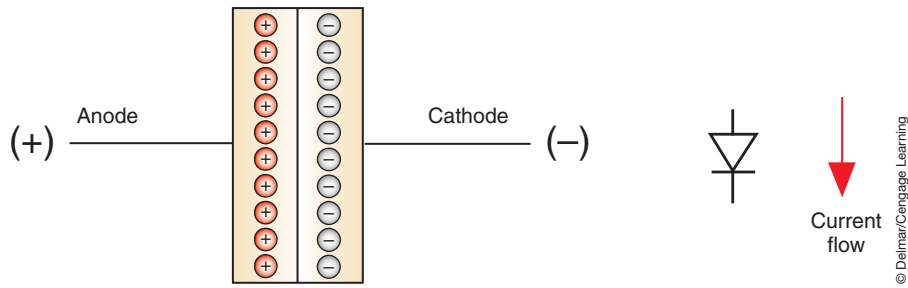


FIGURE 3-20 A diode and its symbol.

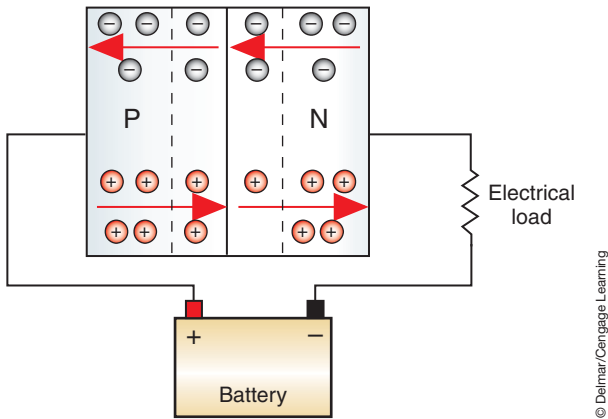


FIGURE 3-21 Forward biased voltage causes current flow.

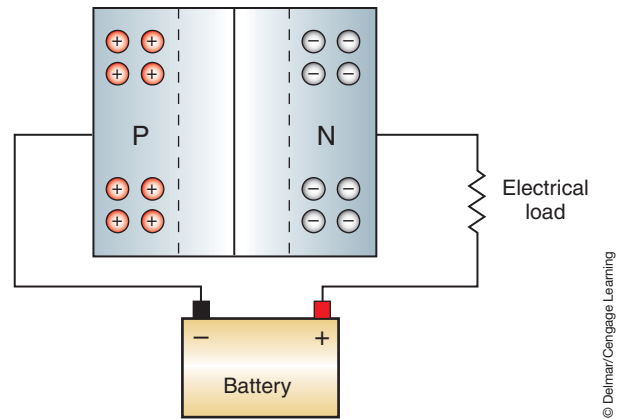


FIGURE 3-22 Reverse bias voltage prevents current flow.

In this state, the negative region will push electrons across the barrier as the positive region pushes holes across. When **forward-biased**, the diode acts as a conductor.

If the diode is **reverse biased**, there will be no current flow (Figure 3-22). The negative region will attract the positive holes away from the junction and the positive region will attract electrons away. This makes the diode act as an insulator.

When the diode is forward biased, it will have a small voltage drop across it. On standard silicon diodes, this voltage is usually about 0.6 volts. This is referred to as the **turn-on voltage**.

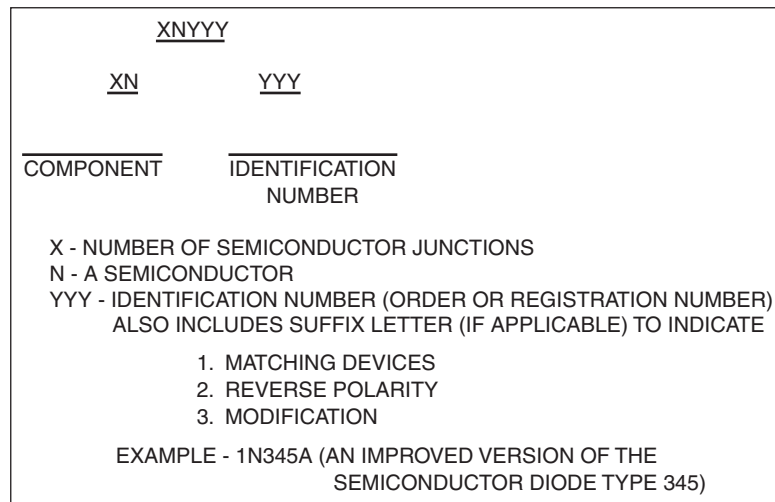
**Diode Identification and Ratings.** Since there are many types of diodes that can vary in size from very small to those capable of withstanding 250 amperes, a semiconductor identification system was developed to distinguish and rate diodes (Figure 3-23). This system is also used to identify transistors and many other special semiconductor devices. The identification system uses a series of numbers and letters to identify different types of semiconductor devices.

The first two characters of the system identify the component. The first number indicates the number of junctions in the semiconductor device. Since this number is one less than the number of active elements, a 1 designates a diode, a 2 designates a transistor, and a 3 designates a tetrode (a four-element transistor). The letter “N” that follows the first number indicates that the device is a semiconductor.

The last series of characters that follow the “N” is a serialized identification number. This number may also contain a suffix letter after the third digit. Common suffix letters that are used include “M” to describe matching pairs of separate semiconductor devices and “R” to indicate reverse polarity. In addition, suffix letters are used to indicate modified versions of the device. For example, a semiconductor diode designated as type 1N345A signifies a two-element diode (1) of semiconductor material (N) that is an improved version (A) of type 345.

**Forward-biased** means that a positive voltage is applied to the P-type material and negative voltage to the N-type material.

**Reverse-biased** means that positive voltage is applied to the N-type material and negative voltage is applied to the P-type material.



© Delmar/Cengage Learning

**FIGURE 3-23** Standard semiconductor identification markings.

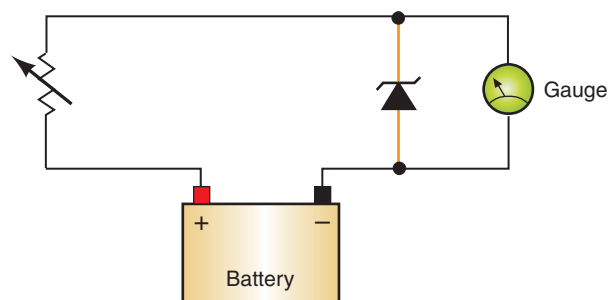
To distinguish the anode from the cathode side of the diode, manufacturers generally code the cathode end of the diode. The identification can be a colored band or a dot, a “k,” “+,” “cath,” or by an unusual shape such as raised edge or taper. Some manufactures will use standard color code bands on the cathode side to not only identify the cathode end of the diode but to identify the diode by number.

## Zener Diodes

As stated, if a diode is reverse biased it will not conduct current. However, if the reverse voltage is increased, a voltage level will be reached at which the diode will conduct in the reverse direction. This voltage level is referred to as **zener voltage**. Reverse current can destroy a simple PN-type diode. But the diode can be doped with materials that will withstand reverse current.

A **zener diode** is designed to operate in reverse bias at the breakdown region. At the point that breakdown voltage is reached, a large current flows in reverse bias. This prevents the voltage from climbing any higher. This makes the zener diode an excellent component for regulating voltage. If the zener diode is rated at 15 volts, it will not conduct in reverse bias when the voltage is below 15 volts. At 15 volts it will conduct and the voltage will not increase over 15 volts.

The illustration (Figure 3-24) shows a simplified circuit that has a zener diode in it to provide a constant voltage level to the instrument gauge. In this example, the zener diode is connected in series with the resistor and in parallel to the gauge. If the voltage to the gauge must be limited to 7 volts, the zener diode used would be rated at 7 volts. The zener diode



© Delmar/Cengage Learning

**FIGURE 3-24** Simplified instrument gauge circuit that uses a zener diode to maintain a constant voltage to the gauge. Note the symbol used for a zener diode.

### Shop Manual

Chapter 3, page 114



## A BIT OF HISTORY

The first diodes were vacuum tube devices (also known as thermionic valves). Arrangements of electrodes were surrounded by a vacuum within a glass envelope that appeared similar to light bulbs. This arrangement of a filament and plate to create a diode was invented by John Ambrose Fleming in 1904. Current flow through the filament

maintains a constant voltage drop, and the total voltage drop in a series circuit must equal the amount of source voltage, thus voltage that is greater than the zener voltage must be dropped over the resistor. Even though source voltage may vary (as a normal result of the charging system), causing different currents to flow through the resistor and zener diode, the voltage that the zener diode drops remains the same.

The zener breaks down when system voltage reaches 7 volts. At this point, the zener diode conducts reverse current, causing an additional voltage drop across the resistor. The amount of voltage to the instrument gauge will remain at 7 volts because the zener diode “makes” the resistor drop the additional voltage to maintain this limit.

Here we see the difference between the standard diode and the zener diode. When the zener diode is reverse biased, the zener holds the available voltage to a specific value.

## Avalanche Diodes

**Avalanche diodes** are diodes that conduct in the reverse direction when the reverse-bias voltage exceeds the breakdown voltage, similar to zener diodes in operation. However, breakdown is done by the avalanche effect. This occurs when the reverse electric field moves across the PN junction and causes a wave of ionization (like an avalanche), leading to a large current. Avalanche diodes are designed to break down at a well-defined reverse voltage without being destroyed. The reverse breakdown voltage is about 6.2 volts or higher. Avalanche diodes are commonly used in automobile AC generators (alternators).

## Light-Emitting Diodes

A **light-emitting diode (LED)** is similar in operation to the diode, except the LED emits light when it is forward biased. An LED has a small lens built into it so that light can be seen when current flows through it (Figure 3-25). When the LED is forward biased, the holes and electrons combine and current is allowed to flow through it. The energy generated is released in the form of light. The light from an LED is not heat energy as is the case with other lights. It is electrical energy. Because of this, LEDs last longer than light bulbs. It is the material used to make the LED that will determine the color of the light emitted, and the turn-on voltage.

Similar to standard silicon diodes, the LED has a constant turn-on voltage. However, this turn-on voltage is usually higher than standard diodes. The turn-on voltage defines the color of the light; 1.2 volts corresponds to red, 2.4 volts to yellow.

## Photo Diodes

A **photo diode** also allows current to flow in one direction only. However, the direction of current flow is opposite a standard diode. Reverse current flow only occurs when the diode receives a specific amount of light. These types of diodes can be used in automatic headlight systems.

## Clamping Diodes

Whenever the current flow through a coil (such as used in a relay or solenoid) is discontinued, a voltage surge or spike is produced. This surge results from the collapsing of the magnetic field around the coil. The movement of the field across the windings induces a very



## A BIT OF HISTORY

(Continued)

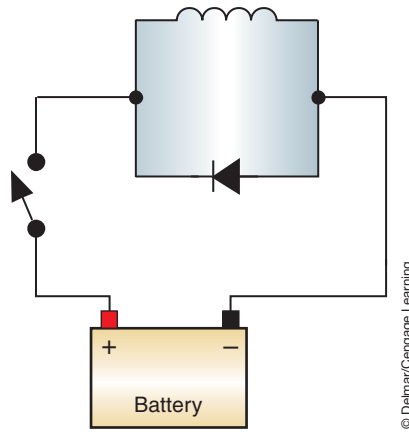
results in generation of heat. When heated, electrons are emitted into the vacuum. These electrons are electrostatically drawn to a positively charged outer metal plate (anode). Since the plate is not heated, the electrons will not return to the filament, even if the charge on the plate is made negative.

**Shop Manual**

Chapter 3, page 114



**FIGURE 3-25** (A) A light-emitting diode uses a lens to emit the generated light. (B) Symbol for LED.



**FIGURE 3-26** A clamping diode in parallel to a coil prevents voltage spikes when the switch is opened.

© Delmar/Cengage Learning

A **clamping diode** is nothing more than a standard diode; the term *clamping* refers to its function.

high voltage spike, which can damage electronic components as it flows through the system. In some circuits, a capacitor can be used as a shock absorber to prevent component damage from this surge. In today's complex electronic systems, a **clamping diode** is commonly used to prevent the voltage spike. By installing a clamping diode in parallel with the coil, a bypass is provided for the electrons during the time that the circuit is open (Figure 3-26).

An example of the use of clamping diodes is on some air conditioning compressor clutches. Because the clutch operates by electromagnetism, opening the clutch coil circuit produces a voltage spike. If this voltage spike was left unchecked, it could damage the vehicle's onboard computers. The installation of the clamping diode prevents the voltage spike from reaching the computers. The clamping diode must be connected to the circuit in reverse bias.

Relays may also be equipped with a clamping diode. However, some use a resistor to dissipate the voltage spike. The two types of relays are not interchangeable.

## Transistors

A **transistor** is a three-layer semiconductor. It is used as a very fast switching device. The word *transistor* is a combination of two words, *transfer* and *resist*. The transistor is used to control current flow in the circuit (Figure 3-27). It can be used to allow a predetermined amount of current flow or to resist this flow.

Transistors are made by combining P-type and N-type materials in groups of three. The two possible combinations are NPN (Figure 3-28) and PNP (Figure 3-29).

The three layers of the transistor are designated as **emitter**, **collector**, and **base**. The emitter is the outside layer of the forward-biased diode that has the same polarity as the circuit side to which it is applied. The arrow on the transistor symbol refers to the emitter lead and points in the direction of positive current flow and to the N material. The collector is the outside layer of

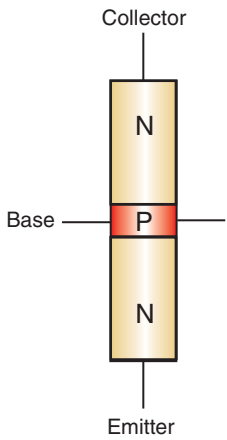


**FIGURE 3-27** Transistors that are used in automotive applications.

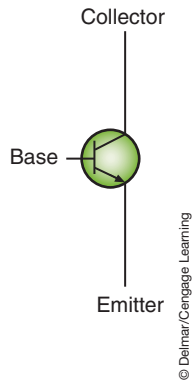
© Delmar/Cengage Learning

### Shop Manual

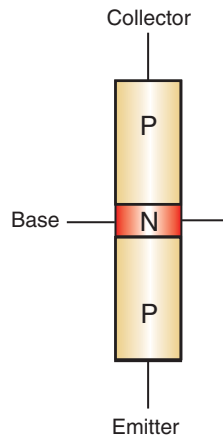
Chapter 3, page 115



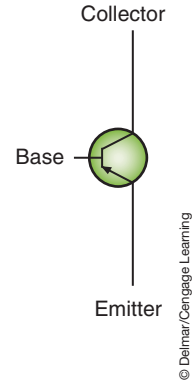
**FIGURE 3-28** An NPN transistor and its symbol.



© Delmar/Cengage Learning



**FIGURE 3-29** A PNP transistor and its symbol.



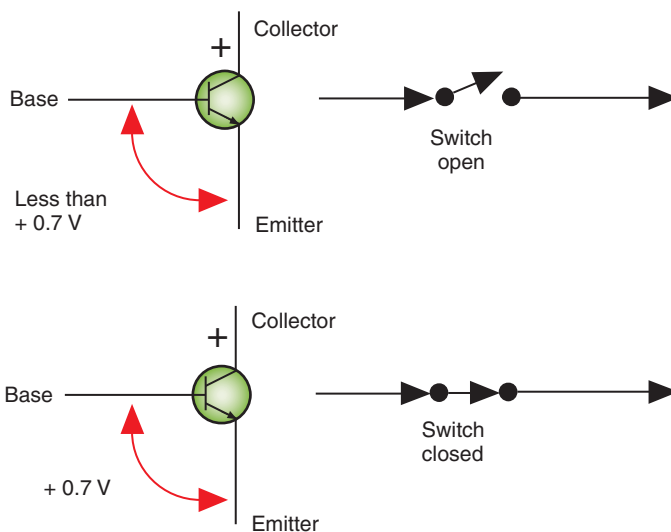
© Delmar/Cengage Learning

the reverse-biased diode. The base is the shared middle layer. Each of these different layers has its own lead for connecting to different parts of the circuit. In effect, a transistor is two diodes that share a common center layer. When a transistor is connected to the circuit, the emitter-base junction will be forward biased and the collector-base junction will be reverse biased.

In the NPN transistor, the emitter conducts current flow to the collector when the base is forward biased. The transistor cannot conduct unless the voltage applied to the base leg exceeds the emitter voltage by approximately 0.7 volt. This means both the base and collector must be positive with respect to the emitter. With less than 0.7 volt applied to the base leg (compared to the voltage at the emitter), the transistor acts as an opened switch. When the voltage difference is greater than 0.7 volt at the base, compared to the emitter voltage, the transistor acts as a closed switch (Figure 3-30).

When an NPN transistor is used in a circuit, it normally has a reverse bias applied to the base-collector junction. If the emitter-base junction is also reverse biased, no current will flow through the transistor (Figure 3-31). If the emitter-base junction is forward biased (Figure 3-32), current flows from the emitter to the base. Because the base is a thin layer and a positive voltage is applied to the collector, electrons flow from the emitter to the collector.

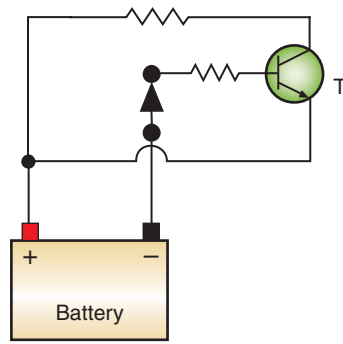
In the PNP transistor, current will flow from the emitter to the collector when the base leg is forward biased with a voltage that is more negative than that at the emitter (Figure 3-33). For current to flow through the emitter to the collector, both the base and the collector must be negative in respect to the emitter.



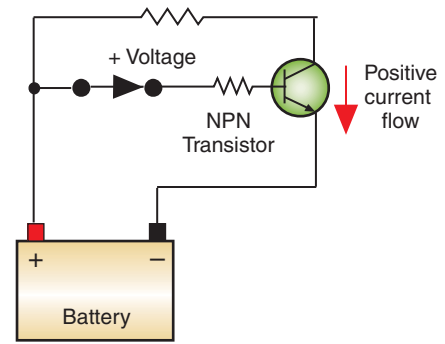
**FIGURE 3-30** NPN transistor action.

© Delmar/Cengage Learning

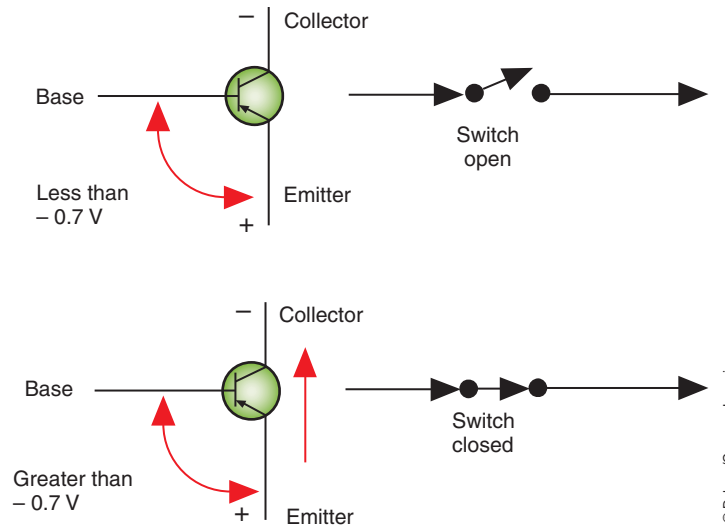




**FIGURE 3-31** NPN transistor with reverse biased voltage applied to the base. No current flow.



**FIGURE 3-32** NPN transistor with forward biased voltage applied to the base. Current flows.



**FIGURE 3-33** PNP transistor action.

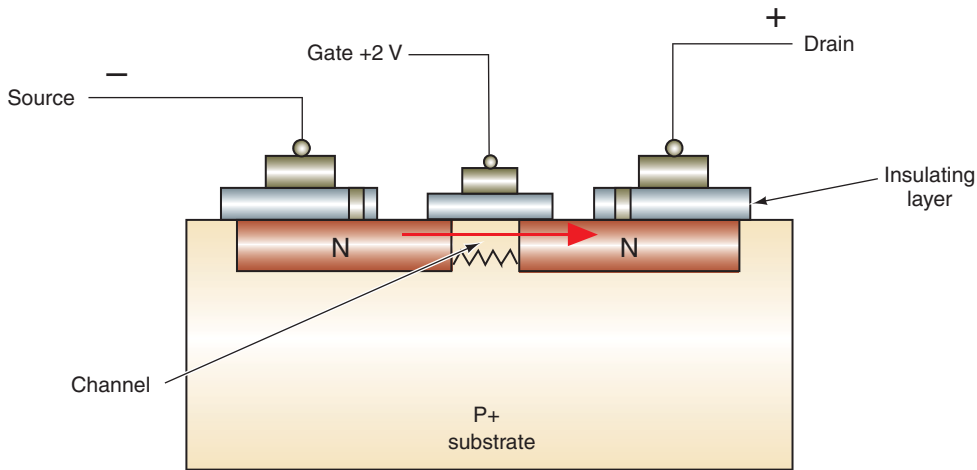
**AUTHOR'S NOTE:** Current flow through transistors is always based on hole and/or electron flow.

Current can be controlled through a transistor. Thus transistors can be used as a very fast electrical switch. It is also possible to control the amount of current flow through the collector. This is because the output current is proportional to the amount of current through the base leg.

A transistor has three operating conditions:

1. **Cutoff:** When reverse-biased voltage is applied to the base leg of the transistor. In this condition the transistor is not conducting and no current will flow.
2. **Conduction:** Bias voltage difference between the base and the emitter has increased to the point that the transistor is switched on. In this condition the transistor is conducting. Output current is proportional to that of the current through the base.
3. **Saturation:** This occurs when the collector to emitter voltage is reduced to near zero by a voltage drop across the collector's resistor.

These types of transistors are called **bipolar** because they have three layers of silicon; two of these layers are the same. Another type of transistor is the **field-effect transistor (FET)**. The FET's leads are listed as source, drain, and gate. The source supplies the electrons and is similar to the emitter in the bipolar transistor. The drain collects the current and is similar to the collector. The gate creates the electrostatic field that allows electron flow from the source to the drain. It is similar to the base.



**FIGURE 3-34** An FET uses a positive voltage to the gate terminal to create a capacitive field to allow electron flow.

© Delmar/Cengage Learning

While electrons are flowing from the source to the drain (electron theory), positive charges are flowing from the drain to the source (conventional theory).

The FET transistor does not require a constant bias voltage. A voltage needs to be applied to the gate terminal to get electron flow from the source to the drain. The source and drain are constructed of the same type of doped material. They can be either N-type or P-type materials. The source and drain are separated by a thin layer of either N-type or P-type material opposite the gate and drain.

Using the illustration (Figure 3-34), if the source voltage is held at 0 volts and 6 volts are applied to the drain, no current will flow between the two. However, if a lower positive voltage is applied to the gate, the gate forms a capacitive field between the channel and itself. The voltage of the capacitive field attracts electrons from the source, and current will flow through the channel to the higher positive voltage of the drain.

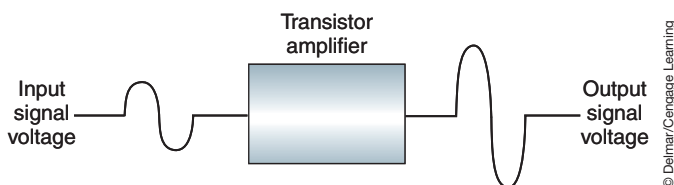
This type of FET is called an **enhancement-type FET** because the field effect improves current flow from the source to the drain. This operation is similar to that of a normally open switch. A **depletion-type FET** is like a normally closed switch, whereas the field effect cuts off current flow from the source to the drain.

## Transistor Amplifiers

A transistor can be used in an amplifier circuit to amplify the voltage. This is useful when using a very small voltage for sensing computer inputs but needing to boost that voltage to operate an accessory (Figure 3-35). The waveform showing the small signal voltage that is applied to the base leg of a transistor may look like that shown (Figure 3-36A). The waveform showing the corresponding signal through the collector will be inverted (Figure 3-36B). Three things happen in an amplified circuit:

1. The amplified voltage at the collector is greater than that of the base voltage.
2. The input current increases.
3. The pattern has been inverted.

Some amplifier circuits use a **Darlington pair**, which is two transistors that are connected together. The first transistor in a Darlington pair is used as a preamplifier to produce a



**FIGURE 3-35** A simplified amplifier circuit.

© Delmar/Cengage Learning

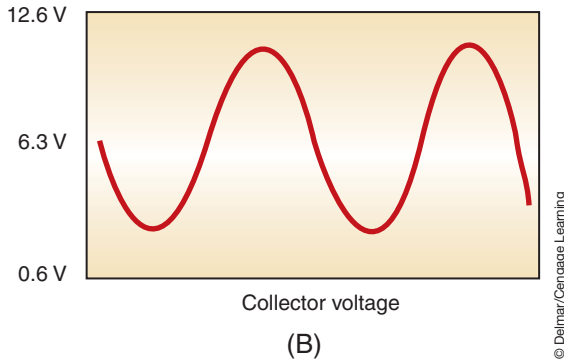
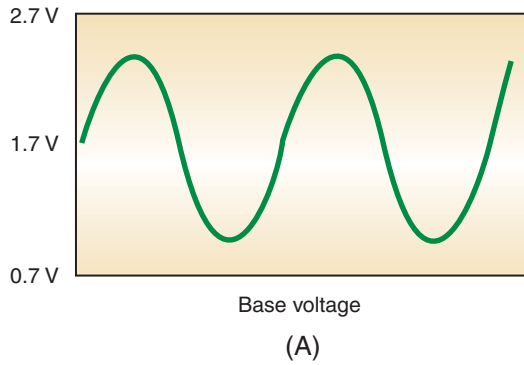


## A BIT OF HISTORY

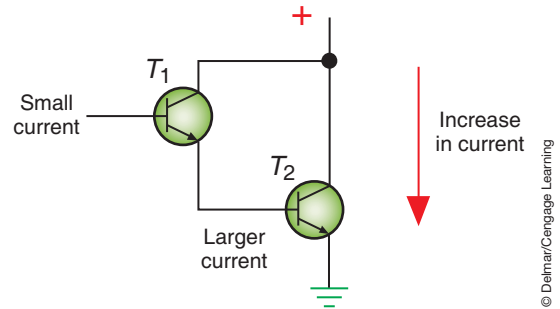
The transistor was developed by a team of three American physicists: Walter Houser Brattain, John Bardeen, and William Bradford Shockley. They announced their achievement in 1948. These physicists won the Nobel Prize in physics for this development in 1956.

## Shop Manual

Chapter 3, page 116



**FIGURE 3-36** The voltage applied to the base (A) is amplified and inverted through the collector (B).



**FIGURE 3-37** A Darlington pair used to amplify current. T1 acts as a preamplifier that creates a larger base current for T2, which is the final amplifier that creates a larger current.

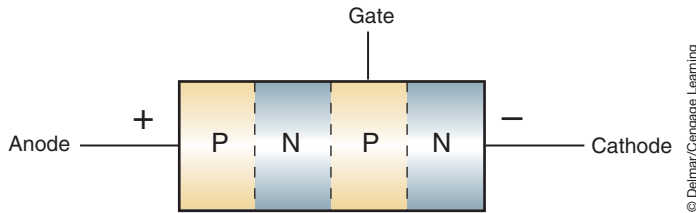
large current to operate the second transistor (Figure 3-37). The second transistor is isolated from the control circuit and is the final amplifier. The second transistor boosts the current to the amount required to operate the load component. The Darlington pair is utilized by most control modules used in electronic ignition systems.

## Phototransistors

A **phototransistor** is a transistor that is sensitive to light. In a phototransistor, a small lens is used to focus incoming light onto the sensitive portion of the transistor (Figure 3-38). When light strikes the transistor, holes and free electrons are formed. These increase current flow through the transistor according to the amount of light. The stronger the light intensity, the



**FIGURE 3-38** Phototransistor.



**FIGURE 3-39** A forward direction SCR.

more current that will flow. This type of phototransistor is often used in automatic headlight dimming circuits.

## Thyristors

A **thyristor** is a semiconductor switching device composed of alternating N and P layers. It can be used to rectify current from AC to DC, and to control power to light dimmers, motor speed controls, solid-state relays, and other applications where power control is needed.

The most common type of thyristor used in automotive applications is the silicon-controlled rectifier (SCR). Like the transistor, the SCR has three legs. However, it consists of four regions arranged PNPN (Figure 3-39). The three legs of the SCR are called the anode (or P-terminal), the cathode (or N-terminal), and the gate (one of the center regions).

The SCR requires only a trigger pulse (not a continuous current) applied to the gate to become conductive. Current will continue to flow through the anode and cathode as long as the voltage remains high enough, or until gate voltage is reversed.

The SCR can be connected into a circuit in either the forward or reverse direction. Using Figure 3-39 of a forward-direction connection, the P-type anode is connected to the positive side of the circuit and the N-type cathode is connected to the negative side. The center PN junction blocks current flow through the anode and cathode.

Once a positive voltage pulse is applied to the gate, the SCR turns on. Even if the positive voltage pulse is removed, the SCR will continue to conduct. If a negative voltage pulse is applied to the gate, the SCR will no longer conduct.

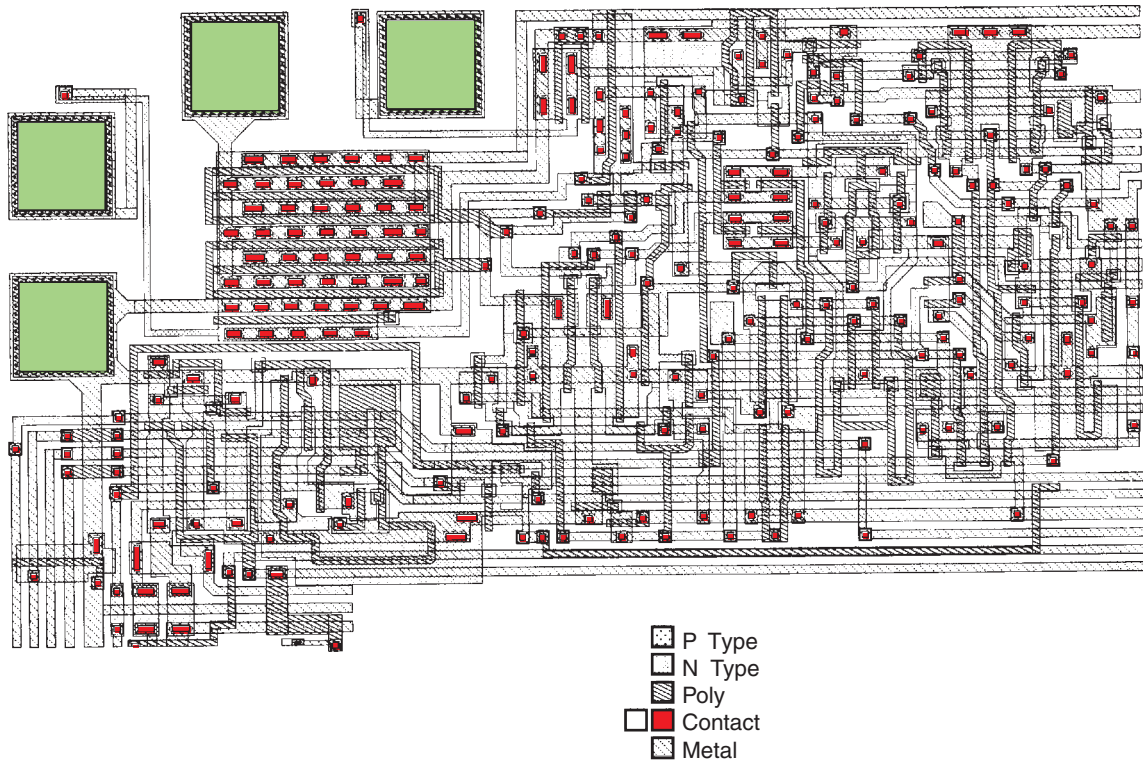
The SCR will also block any reverse current from flowing from the cathode to the anode. Because current can flow in only one direction through the SCR, it can rectify AC current to DC current.

## Integrated Circuits

An **integrated circuit (IC)** is a complex circuit of thousands of transistors, diodes, resistors, capacitors, and other electronic devices that are formed onto a tiny silicon chip (Figure 3-40). As many as 30,000 transistors can be placed on a chip that is 1/4 inch (6.35 mm) square.

Integrated circuits are constructed by photographically reproducing circuit patterns onto a silicon wafer. The process begins with a large-scale drawing of the circuit. This drawing can be room size. Photographs of the circuit drawing are reduced until they are the actual size of the circuit. The reduced photographs are used as a mask. Conductive P-type and N-type materials, along with insulating materials, are deposited onto the silicon wafer. The mask is placed over the wafer and selectively exposes the portion of material to be etched away or the portions requiring selective deposition. The entire process of creating an integrated circuit chip takes over 100 separate steps. Out of a single wafer 4 inches (101.6 mm) in diameter, thousands of integrated circuits can be produced.

The small size of the integrated chip has made it possible for the vehicle manufacturers to add several computer-controlled systems to the vehicle without taking up much space. Also, a single computer is capable of performing several functions.



**FIGURE 3-40** An enlarged illustration of an integrated circuit with thousands of transistors, diodes, resistors, and capacitors. Actual size can be less than ¼ inch (6.35 mm) square.

© Delmar/Cengage Learning

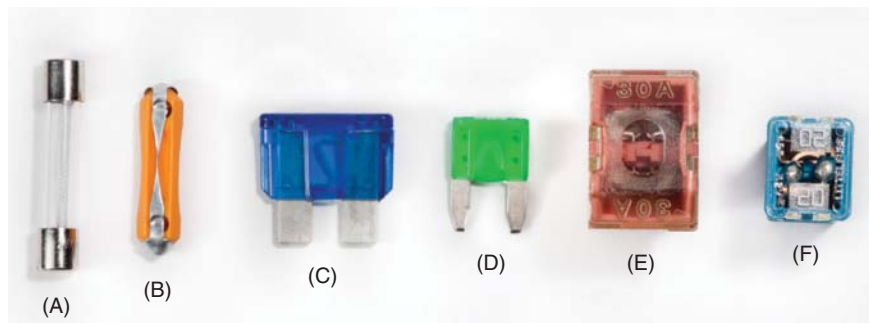
**Shop Manual**  
Chapter 3, page 104

## CIRCUIT PROTECTION DEVICES

Most automotive electrical circuits are protected from high current flow that would exceed the capacity of the circuit's conductors and/or loads. Excessive current results from a decrease in the circuit's resistance. Circuit resistance will decrease when too many components are connected in parallel or when a component or wire becomes shorted. A short is an undesirable, low-resistance path for current flow. When the circuit's current reaches a predetermined level, most circuit **protection devices** open and stop current flow in the circuit. This action prevents damage to the wires and the circuit's components.

### Fuses

The most commonly used circuit protection device is the **fuse** (Figure 3-41). A fuse is a replaceable element that contains a metal strip that will melt when the current flowing through it exceeds its rating. The thickness of the metal strip determines the rating of the



© Delmar/Cengage Learning

**FIGURE 3-41** Common fuses (A) glass cartage, (B) ceramic, (C) blade (Auto-fuse), (D) mini, (E) maxi, and (F) "F" type.



fuse. When the metal strip melts, excessive current is indicated. The cause of the **overload** must be found and repaired; then a new fuse of the same rating should be installed. The most commonly used automotive fuses are rated from 3 to 30 amps.

There are three basic types of fuses: glass or ceramic fuses, blade-type fuses, and bullet or cartridge fuses. Glass and ceramic fuses are found mostly on older vehicles. Sometimes, however, you can find them in a special holder connected in series with a circuit. Glass fuses are small glass cylinders with metal caps. The metal strip connects the two caps. The rating of the fuse is normally marked on one of the caps.

Blade-type fuses are flat plastic units and are available in three different physical sizes: mini, standard, and maxi (Figure 3-42). The plastic housing is formed around two male blade-type connectors. The metal strip connects these connectors inside the plastic housing. The rating of these fuses is on top of the plastic housing and the plastic is color coded (Figure 3-43).

Cartridge-type fuses are used in many European vehicles. These fuses are made of plastic or ceramic material. They have pointed ends and the metal strip rounds from end to end. This type of fuse is much like a glass fuse except the metal strip is not enclosed.

Fuses are typically located in a central **fuse block** or power distribution box. However, fuses may also be found in relay boxes and electrical junction boxes. Power distribution boxes are normally located in the engine compartment and house fuses and relays. A common location for a fuse box is under the instrumental panel (Figure 3-44). The fuse box may also be located behind kick panels, in the glove box, in the engine compartment, or in a variety of other places on the vehicle. Fuse ratings and the circuits they protect are normally marked on the cover of the fuse or power distribution box. Of course, this information can also be found in the vehicle's owner's manual and the service information.

A fuse is connected in series with the circuit. Normally the fuse is located before all of the loads of the circuit (Figure 3-46). However, it may be placed before an individual load (Figure 3-47).

When adding accessories to the vehicle, the correct fuse rating must be selected. Use the power formula to determine the correct fuse rating ( $\text{watts} \div \text{volts} = \text{amperes}$ ). The fuse

Excess current flow in a circuit is called an **overload**.

A "blown" fuse is identified by a burned-through metal wire in the capsule (Figure 3-45).

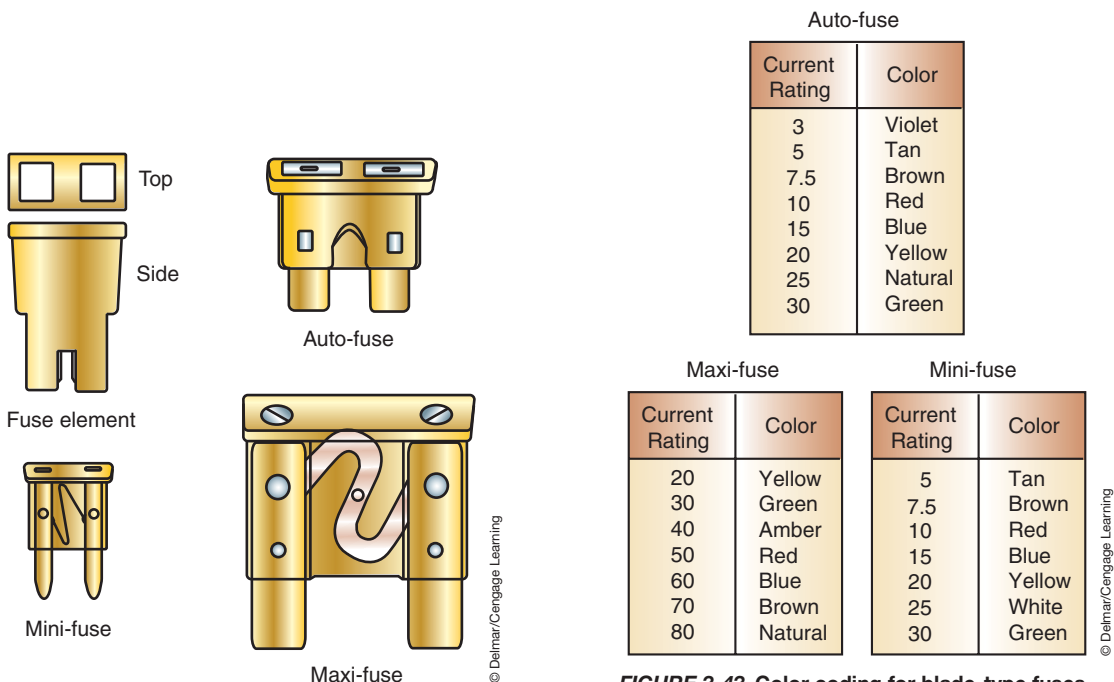


FIGURE 3-42 Types of blade fuses.

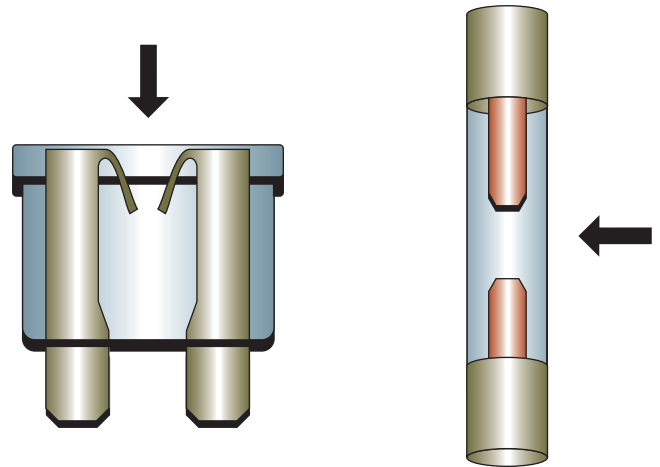
FIGURE 3-43 Color coding for blade-type fuses. An auto-fuse is a standard blade-type fuse.





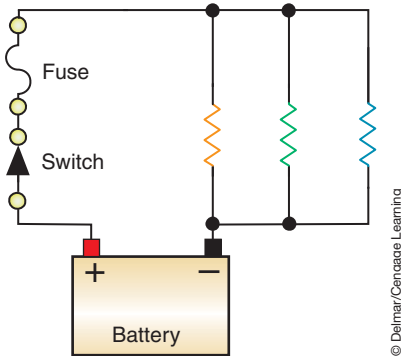
**FIGURE 3-44** Fuse boxes are normally located under the dash or in the engine compartment.

© Delmar/Cengage Learning



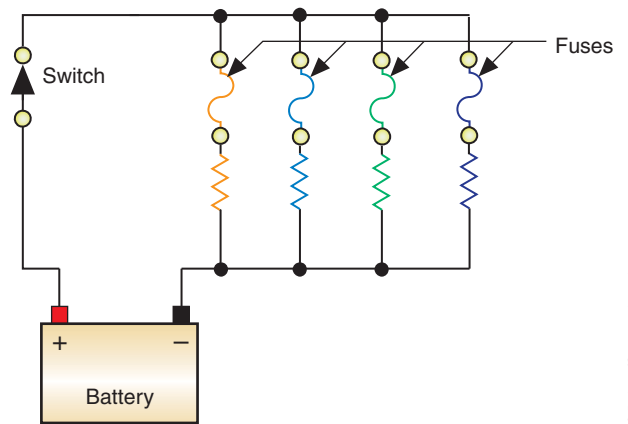
**FIGURE 3-45** Blown fuses.

© Delmar/Cengage Learning



**FIGURE 3-46** One fuse to protect the entire parallel circuit.

© Delmar/Cengage Learning



**FIGURE 3-47** Fuses used to protect each branch of a parallel circuit.

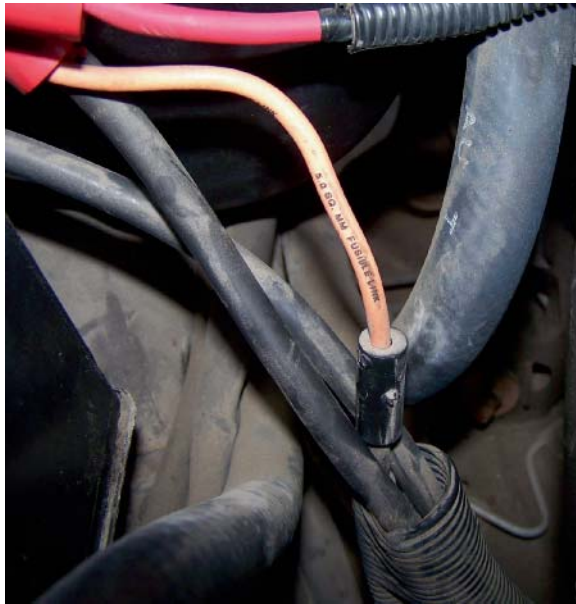
© Delmar/Cengage Learning

selected should be rated slightly higher than the actual current draw to allow for current surges (5% to 10%).

## Fusible Links

**Fusible links** are made of meltable conductor material with a special heat-resistant insulation. When there is an overload in the circuit, the conductor link melts and opens the circuit. To properly test a fusible link, use an ohmmeter or continuity tester. A vehicle may have one or several fusible links to provide protection for the main power wires before they are divided into smaller circuits at the fuse box. The fusible links are usually located at a main connection near the battery or starter solenoid (Figure 3-48). The current capacity of a fusible link is determined by its size. A fusible link is usually four wire sizes smaller (four numbers larger) than the circuit it protects. The smaller the wire, the larger its number. A circuit that uses 14-gauge wire would require an 18-gauge fusible link for protection.

**AUTHOR'S NOTE:** Some GM vehicles have the fusible link located at the main connection near the starter motor.



© Delmar/Cengage Learning

**FIGURE 3-48** Fusible links located near the battery.

**AUTHOR'S NOTE:** A “blown” fusible link is usually identified by bubbling of the insulator material around the link.

## Maxi-Fuses

In place of fusible links, many manufacturers use a **maxi-fuse**. A maxi-fuse looks similar to a blade-type fuse except it is larger and has a higher current capacity. It is also referred to as a cartridge fuse. By using maxi-fuses, manufacturers are able to break down the electrical system into smaller circuits. If a fusible link burns out, many of the vehicle's electrical systems may be affected. By breaking down the electrical system into smaller circuits and installing maxi-fuses, the consequence of a circuit defect will not be as severe as it would have been with a fusible link. In place of a single fusible link, there may be many maxi-fuses, depending on how the circuits are divided. This makes the technician's job of diagnosing a faulty circuit much easier.

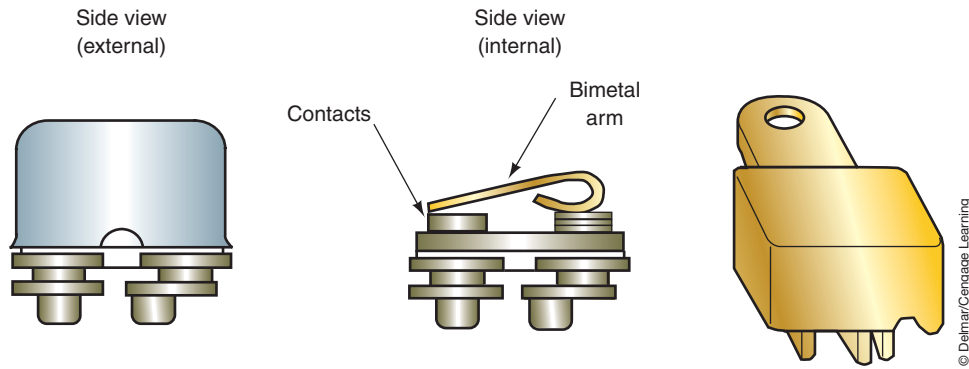
Maxi-fuses are used because they are less likely to cause an underhood fire when there is an overload in the circuit. If the fusible link is burned in two, it is possible that the “hot” side of the fuse can come into contact with the vehicle frame and the wire can catch on fire.

Today many manufacturers are replacing maxi-fuses with “F”-type fuses. These are smaller versions of the maxi-fuses.

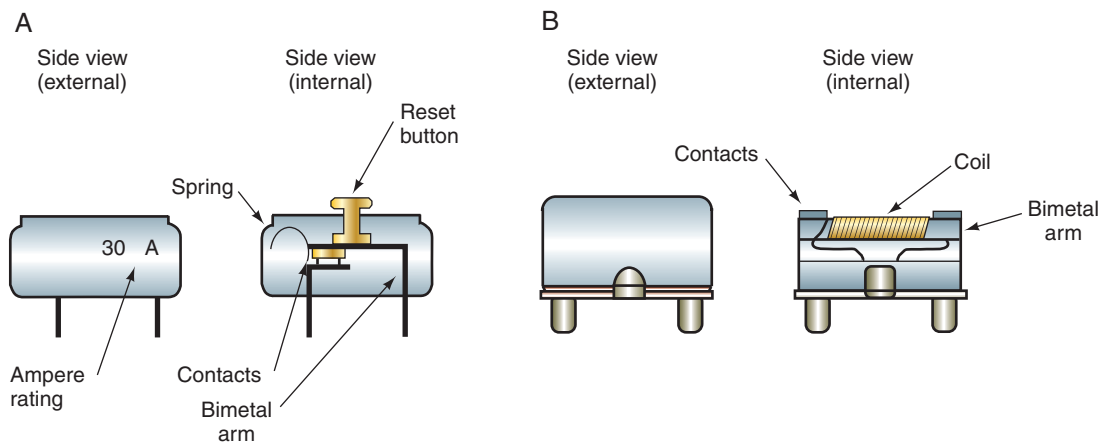
## Circuit Breakers

A circuit that is susceptible to an overload on a routine basis is usually protected by a **circuit breaker**. A circuit breaker uses a **bimetallic strip** that reacts to excessive current (Figure 3-49). When an overload or circuit defect occurs that causes an excessive amount of current draw, the current flowing through the bimetallic strip causes it to heat. As the strip heats, it bends and opens the contacts. Once the contacts are opened, current can no longer flow. With no current flowing, the strip cools and closes again. If the excessive current cause is still in the circuit, the breaker will open again. The circuit breaker will continue to open and close as long as the overload is in the circuit. This type of circuit breaker is self-resetting or “cycled.” Some circuit breakers require manual resetting by pressing a button, while others must be removed from the power to reset (Figure 3-50).

**A bimetallic strip** consists of two different types of metals. One strip will react more quickly to heat than the other, which causes the strip to flex in proportion to the amount of current flow.



**FIGURE 3-49** The circuit breaker uses a bimetallic strip that opens if current draw is excessive.



**FIGURE 3-50** Non-cycling circuit breakers. (A) can be reset by pressing the button, while (B) requires being removed from the power to reset.

An example of the use of a circuit breaker is in the power window circuit. Because the window is susceptible to jams due to ice buildup on the window, a current overload is possible. If this should occur, the circuit breaker will heat up and open the circuit before the window motor is damaged. If the operator continues to attempt to operate the power window, the circuit breaker will open and close until the cause of the jam is removed.

### PTCs as Circuit Protection Devices

Automotive engineers are faced with conflicting needs to provide reliable circuit protection against shorts to ground or other overload conditions yet at the same time to reduce vehicle weight and cost. Traditionally, fuses are used to protect multiple circuits. However, this results in large, heavy, and complex wiring assemblies. The use of polymer, **positive temperature coefficient (PTC)** resistors provides a means of meeting these needs. A PTC resistor increases in resistance as temperature increases. Because of its design, a PTC resistor has the ability to trip (increase resistance to the point it becomes the load device in the circuit) during an over-current condition and reset after the fault is no longer present (Figure 3-51).

Conductive polymers consist of specially formulated plastics and various conductive materials. At normal temperatures, the plastic materials form a crystalline structure. The structure provides a low-resistance conductive chain. The resistance is so low that it does not affect the operation of the circuit. However, if the current flow increases above the trip threshold, the additional heat causes the crystalline structure to change to an amorphous

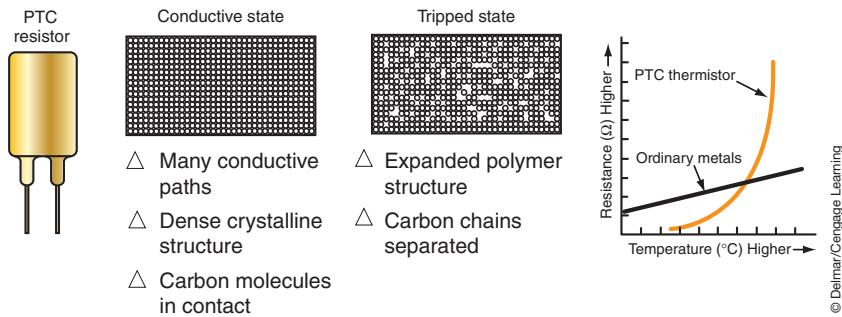


FIGURE 3-51 PTC operation.

state. In this condition, the conductive paths separate, causing a rapid increase in the resistance of the PTC. The increased resistance reduces the current flow to a safe level.

## CIRCUIT DEFECTS

All electrical problems can be classified as being one of three types of problems: an open, short, or high resistance. Each one of these will cause a component to operate incorrectly or not at all. Understanding what each of these problems will do to a circuit is the key to proper diagnosis of any electrical problem.

### Open

An **open** is simply a break in the circuit (Figure 3-52). An open is caused by turning a switch off, a break in a wire, a burned-out light bulb, a disconnected wire or connector, or anything that opens the circuit. When a circuit is open, current does not flow and the component doesn't work. Because there is no current flow, there are no voltage drops in the circuit. Source voltage is available everywhere in the circuit up to the point at which it is open. Source voltage is even available after a load, if the open is after that point.

Opens caused by a blown fuse will still cause the circuit not to operate, but the cause of the problem is the excessive current that blew the fuse. Nearly all other opens are caused by a break in the continuity of the circuit. These breaks can occur anywhere in the circuit.

### Shorts

A **short** results from an unwanted path for current. **Shorted circuits** cause an increase in current flow by bypassing part of the normal circuit path. This increased current flow can burn wires or components.

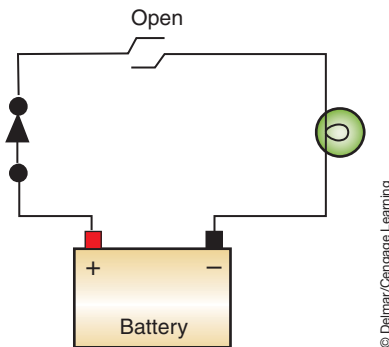


FIGURE 3-52 An open circuit stops all current flow.

Shop Manual  
Chapter 3, page 96

Shop Manual  
Chapter 3, page 97

An example of a shorted circuit could be found in a faulty coil. The windings within a coil are insulated from each other; however, if this insulation breaks down, a copper-to-copper contact is made between the turns. Since part of the windings will be bypassed, this reduces the number of windings in the coil through which current will flow. This results in the effectiveness of the coil being reduced. Also, since the current bypasses a portion of the normal circuit resistance, current flow is increased and excess heat can be generated.

Another example of a shorted circuit is if the insulation of two adjacent wires breaks down and allows a copper-to-copper contact (Figure 3-53). If the short is between points A and B, light 1 would be on all the time. If the short is between points B and C, both lights would illuminate when either switch is closed.

Another example is shown in Figure 3-54. With the two wires shorted together, the horn will sound every time the brake pedal is depressed. Also, if the horn button is pressed, the brake lights will come on.

Another type of electrical defect is a short to ground. A short to ground allows current to flow an unintentional path to ground (Figure 3-55). To see what happens in a circuit that has a short to ground, refer to Figure 3-56. If normal resistance of the two bulbs is 3 ohms and 6 ohms, since they are in parallel, the total circuit resistance is 2 ohms. The short makes a path from the power side of one bulb to the return path, and to the battery. The short creates a low-resistance path. If the low-resistance path has a resistance value of 0.001 ohms, it is possible to calculate what would happen to the current in this circuit.

The short becomes another leg in the parallel circuit. Since the total resistance of a parallel circuit is always lower than the lowest resistance, we know the total resistance of the circuit is now less than 0.001 ohms. Using Ohm's law we can calculate the current flow through the circuit.

$$A = V/R \quad \text{or} \quad A = 12/.001 \quad \text{or} \quad A = 12,000 \text{ Amps}$$

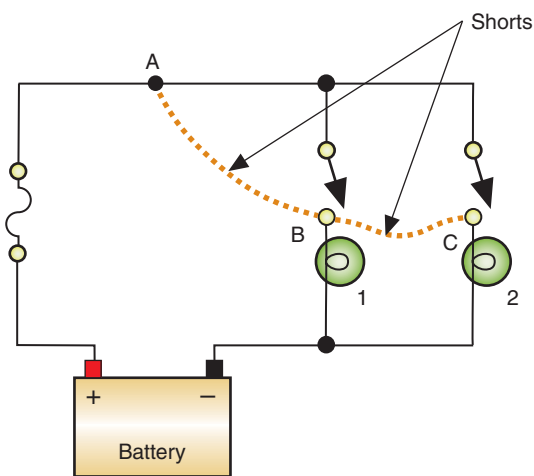


FIGURE 3-53 A short circuit can be a copper-to-copper contact between two adjacent wires.

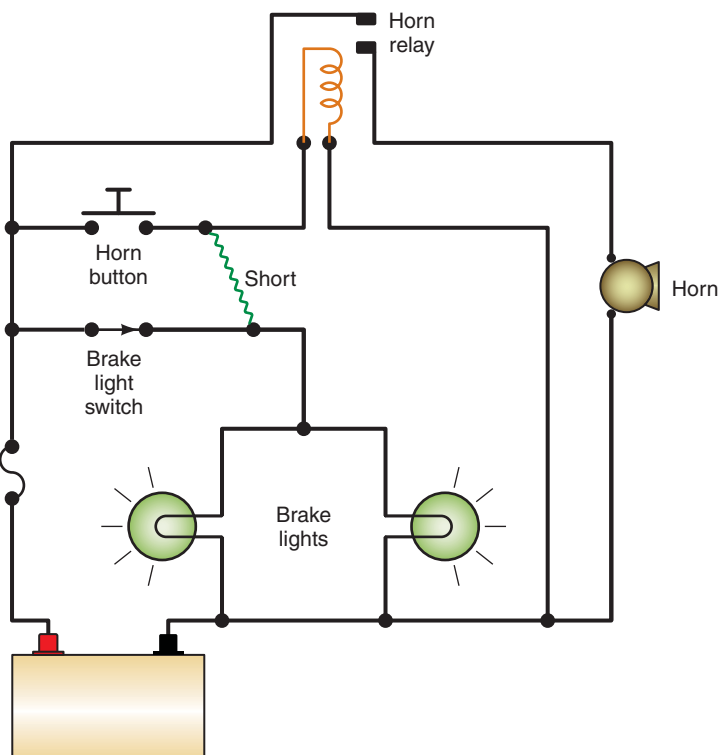
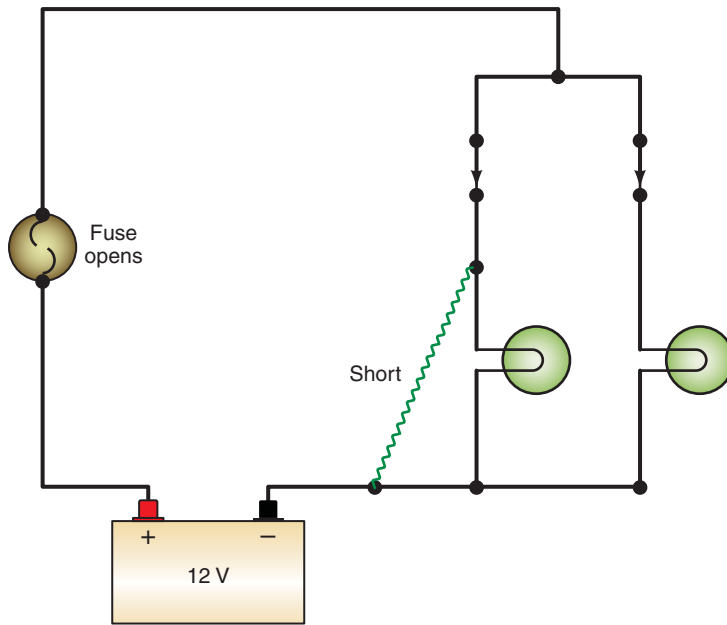
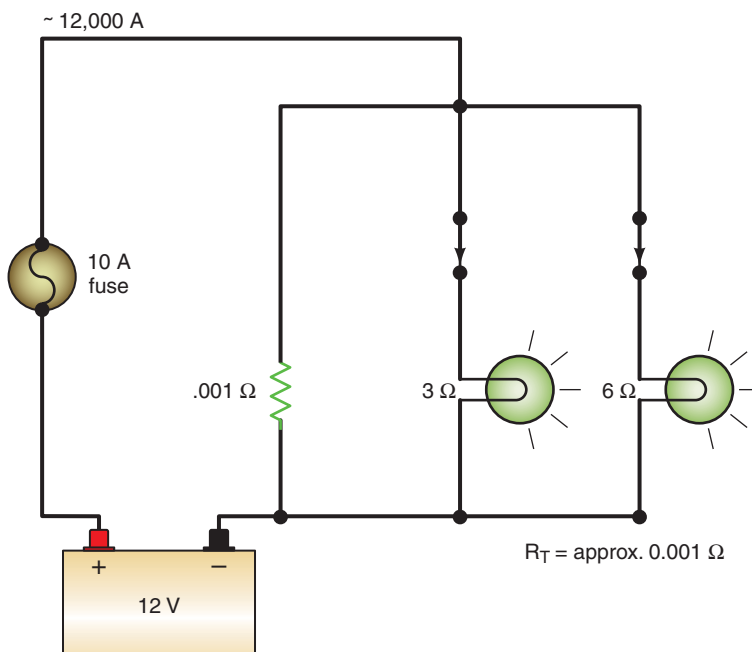


FIGURE 3-54 A wire-to-wire short.



© Delmar/Cengage Learning

FIGURE 3-55 A grounded circuit.



© Delmar/Cengage Learning

FIGURE 3-56 Ohm's law applied to Figure 3-55.

Needless to say, it would take a large wire to carry that kind of amperage. Our 10-amp fuse would melt quickly when the short occurred. This would protect the wires and light bulbs.

## High Resistance

High-resistance problems occur when there is unwanted resistance in the circuit. The high resistance can come from a loose connection, corroded connection, corrosion in the wire, wrong size wire, and so on. Since the resistance becomes an additional load in the circuit, the effect is that the load component, with reduced voltage and current applied, operates with reduced efficiency. An example would be a taillight circuit with a load component (light bulb)



## TERMS TO KNOW

Anode  
Avalanche diodes  
Base  
Bimetallic strip  
Bipolar  
Buzzer  
Cathode  
Circuit breaker  
Clamping diode  
Collector  
Covalent bonding  
Crystal  
Darlington pair  
Depletion-type FET  
Diode  
Emitter  
Enhancement-type FET  
Field-effect transistor (FET)  
Fixed resistors  
Forward-biased  
Fuse  
Fuse block  
Fusible links  
Ganged switch  
Hole  
Integrated circuit (IC)  
ISO relays  
Light-emitting diode (LED)  
Load device  
Maxi-fuse  
Normally closed (NC)  
Normally open (NO)  
N-type material  
Open  
Overload  
Peak reverse voltage (PRV)  
Photo diode  
Phototransistor  
Pole  
Positive temperature coefficient (PTC)  
Potentiometer  
Protection devices

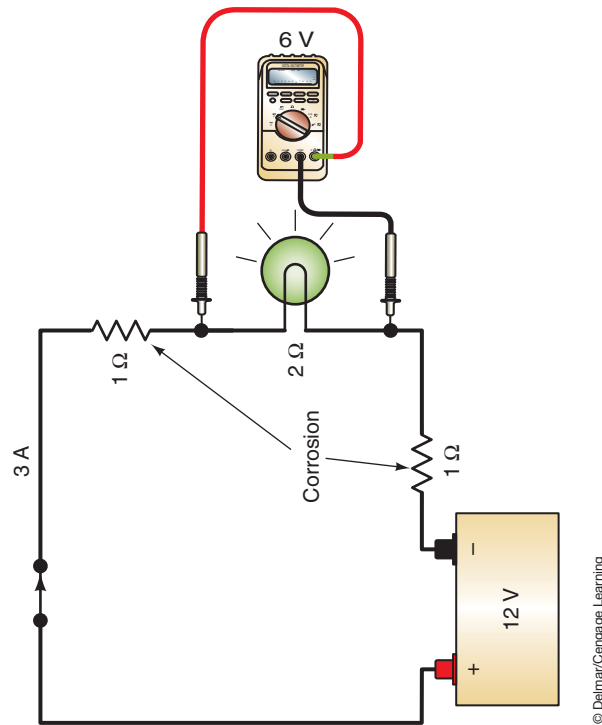


FIGURE 3-57 A simple light circuit with unwanted resistance.

that is rated at 50 watts. To be fully effective, this bulb must draw 4.2 amperes at 12 volts ( $A = P \div V$ ). This means a full 12 volts should be applied to the bulb. If resistance is present at other points in the circuit, some of the 12 volts will be dropped. With less voltage (and current) being available to the light bulb, the bulb will illuminate with less intensity.

Figure 3-57 illustrates a light circuit with unwanted resistance at the power feed for the bulb and at the negative battery terminal. When the circuit is operating properly, the 2-ohm light bulb will have 6 amps of current flowing through it and drop 12 volts. With the added resistance, the current is reduced to 3 amps and the bulb drops only 6 volts. As a result, the bulb's illumination is very dim.

## SUMMARY

- A switch can control the on/off operation of a circuit or direct the flow of current through various circuits.
- A normally open switch will not allow current flow when it is in its rest position. A normally closed switch will allow current flow when it is in its rest position.
- A relay is a device that uses low current to control a high-current circuit.
- A buzzer is sometimes used to warn the driver of possible safety hazards by emitting an audio signal (such as when the seat belt is not buckled).
- A stepped resistor has two or more fixed resistor values. It is commonly used to control electrical motor speeds.
- A variable resistor provides for an infinite number of resistance values within a range. A rheostat is a two-terminal variable resistor used to regulate the strength of an electrical current. A potentiometer is a three-wire variable resistor that acts as a voltage

divider to produce a continuously variable output signal proportional to a mechanical position.

- A diode is an electrical one-way check valve that will allow current to flow in one direction only.
- Forward bias means that a positive voltage is applied to the P-type material and negative voltage to the N-type material. Reverse bias means that positive voltage is applied to the N-type material and negative voltage is applied to the P-type material.
- A transistor is a three-layer semiconductor that is commonly used as a very fast switching device.
- An integrated circuit is a complex circuit of thousands of transistors, diodes, resistors, capacitors, and other electronic devices that are formed onto a tiny silicon chip.
- The protection device is designed to “turn off” the system it protects. This is done by creating an open (like turning off a switch) to prevent a complete circuit.
- Fuses are rated by amperage. Never install a larger rated fuse into a circuit than the one that was designed by the manufacturer. Doing so may damage or destroy the circuit.
- An open circuit is a circuit in which there is a break in continuity.
- A shorted circuit is a circuit that allows current to bypass part of the normal path.
- A short to ground is a condition that allows current to return to ground before it has reached the intended load component.

## TERMS TO KNOW

(continued)

Relays  
Reverse-biased  
Rheostat  
Short  
Short circuits  
Solenoid  
Sound generator  
Stepped resistor  
Throw  
Thyristor  
Transistor  
Turn-on voltage  
Variable resistors  
Wiper  
Zener diode  
Zener voltage

## REVIEW QUESTIONS

### Short-Answer Essays

1. Describe the use of three types of semiconductors.
2. What types of mechanical variable resistors are used on automobiles?
3. Define what is meant by opens, shorts, grounds, and excessive resistance.
4. Explain the effects that each type of circuit defect will have on the operation of the electrical system.
5. Explain the purpose of a circuit protection device.
6. Describe the most common types of circuit protection devices.
7. Describe the common types of electrical system (non-electric) components used and how they affect the electrical system.
8. Describe the difference between a rheostat and a potentiometer.
9. Explain the difference between normally open (NO) and normally closed (NC) switches.
10. Explain the differences between forward biasing and reverse biasing a diode.

### Fill in the Blanks

1. Never install a larger rated \_\_\_\_\_ into a circuit than the one that was designed by the manufacturer.
2. A \_\_\_\_\_ can control the on/off operation of a circuit or direct the flow of current through various circuits.
3. A normally \_\_\_\_\_ switch will not allow current flow when it is in its rest position. A normally \_\_\_\_\_ switch will allow current flow when it is in its rest position.
4. An \_\_\_\_\_ is a complex circuit of many transistors, diodes, resistors, capacitors, and other electronic devices that are formed onto a tiny silicon chip.
5. When a \_\_\_\_\_ voltage is applied to the P-material of a diode and \_\_\_\_\_ voltage is applied to the N-material, the diode is reverse biased. When a \_\_\_\_\_ voltage is applied to the N-material of a diode and \_\_\_\_\_ voltage is applied to the P-material, the diode is forward biased.

6. A \_\_\_\_\_ is used in electronic circuits as a very fast switching device.
7. A \_\_\_\_\_ is an electrical one-way check valve that will allow current to flow in one direction only.
8. A \_\_\_\_\_ is an electromechanical device that uses low current to control a high-current circuit.
9. A \_\_\_\_\_ is a three-wire variable resistor that acts as a voltage divider. A \_\_\_\_\_ is a two-terminal variable resistor used to regulate the strength of an electrical current.
10. The \_\_\_\_\_ requires only a trigger pulse applied to the gate to become conductive.

## MULTIPLE CHOICE

---

1. All of the following are true concerning electrical shorts, EXCEPT:
  - A. A short can add a parallel leg to the circuit, which lowers the entire circuit's resistance.
  - B. A short can result in a blown fuse.
  - C. A short decreases amperage in the circuit.
  - D. A short bypasses the circuit's intended path.
2. Which statement is true concerning circuit protection devices?
  - A. A fuse automatically resets after the cause of the overload is repaired.
  - B. Circuit protection devices create an open when an overload occurs.
  - C. An open circuit can cause a blown fuse.
  - D. Fuses are rated according to the voltage limits.
3. All of the statements concerning circuit components are true, EXCEPT:
  - A. A switch can control the on/off operation of a circuit.
  - B. A switch can direct the flow of current through various circuits.
  - C. A relay can be an SPDT-type switch.
  - D. A potentiometer changes voltage drop due to the function of temperature.
4. Which of the following statements is/are correct?
  - A. A zener diode is an excellent component for regulating voltage.
  - B. A reverse-biased diode lasts longer than a forward-biased diode.
  - C. The switches of a transistor last longer than those of a relay.
  - D. Both a and c.
5. The light-emitting diode (LED):
  - A. Emits light when it is reverse biased.
  - B. Has a variable turn-on voltage.
  - C. Has a light color that is defined by the materials used to construct the diode.
  - D. Has a turn-on voltage that is usually less than standard diodes.
6. Which of the following is the correct statement?
  - A. An open means that there is continuity in the circuit.
  - B. A short bypasses a portion of the circuit.
  - C. High amperage draw indicates an open circuit.
  - D. High resistance in a circuit increases current flow.
7. Transistors:
  - A. Can be used to control the switching on/off of a circuit.
  - B. Can be used to amplify voltage.
  - C. Control high current with low current.
  - D. All of the above.
8. All of the following are true, EXCEPT:
  - A. Voltage drop can cause a lamp in a parallel circuit to burn brighter than normal.
  - B. Excessive voltage drop may appear on either the insulated or grounded return side of a circuit.
  - C. Increased resistance in a circuit decreases current.
  - D. A diode is used as an electrical one-way check valve.

9. Which statement is correct concerning diodes?
- A. Diodes are aligned to allow current flow in one direction only.
  - B. Diodes can be used to rectify DC voltages into AC voltages.
  - C. The stripe is on the anode side of the diode.
  - D. Normal turn-on voltage of a standard diode is 1.5 volts.
10. A “blown” fusible link is identified by:
- A. A burned-through metal wire in the capsule.
  - B. A bubbling of the insulator material around the link.
  - C. All of the above.
  - D. None of the above.

## Chapter 4

# WIRING AND CIRCUIT DIAGRAMS

### UPON COMPLETION AND REVIEW OF THIS CHAPTER, YOU SHOULD BE ABLE TO UNDERSTAND AND DESCRIBE:

- When single-stranded or multistranded wire should be used.
- The use of resistive wires in a circuit.
- The construction of spark plug wires.
- How wire size is determined by the American Wire Gauge (AWG) and metric methods.
- How to determine the correct wire gauge to be used in a circuit.
- How temperature affects resistance and wire size selection.
- The purpose and use of printed circuits.
- Why wiring harnesses are used and how they are constructed.
- The purpose of wiring diagrams.
- The common electrical symbols that are used.
- The purpose of the component locator.

### INTRODUCTION

Today's vehicles have a vast amount of electrical wiring that, if laid end to end, could stretch for half a mile or more. Today's technician must be proficient at reading wiring diagrams in order to sort through this great maze of wires. Trying to locate the cause of an electrical problem can be quite difficult if you do not have a good understanding of wiring systems and diagrams.

In this chapter, you will learn how wiring harnesses are made (Figure 4-1), how to read the wiring diagram, how to interpret the symbols used, and how terminals are used. This will reduce the amount of confusion you may experience when repairing an electrical circuit. It is also important to understand how to determine the correct type and size of wire to carry the anticipated amount of current. It is possible to cause an electrical problem by simply using the wrong gauge size of wire. A technician must understand the three factors that cause resistance in a wire—length, diameter, and temperature—to perform repairs correctly.

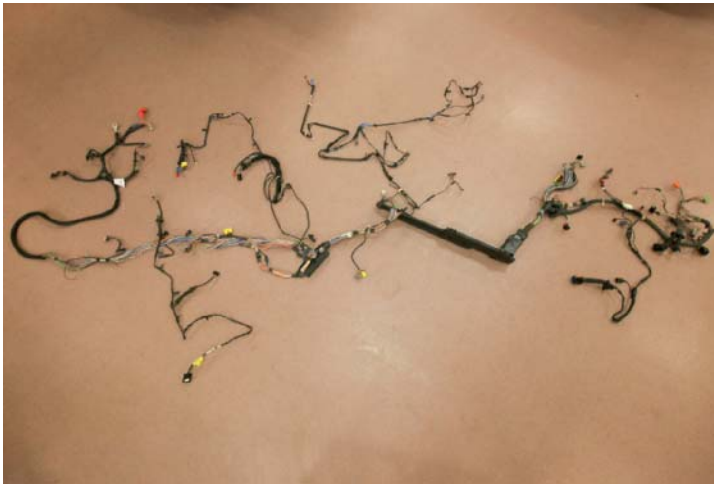
### AUTOMOTIVE WIRING

**Primary wiring** is the term used for conductors that carry low voltage. The insulation of primary wires is usually thin. **Secondary wiring** refers to wires used to carry high voltage, such as ignition spark plug wires. Secondary wires have extra-thick insulation.

Most of the primary wiring conductors used in the automobile are made of several strands of copper wire wound together and covered with a polyvinyl chloride (PVC) insulation (Figure 4-2). Copper has low resistance and can be connected to easily by using crimping connectors or soldered connections. Other types of conductor materials used in automobiles include silver, gold, aluminum, and tin-plated brass.

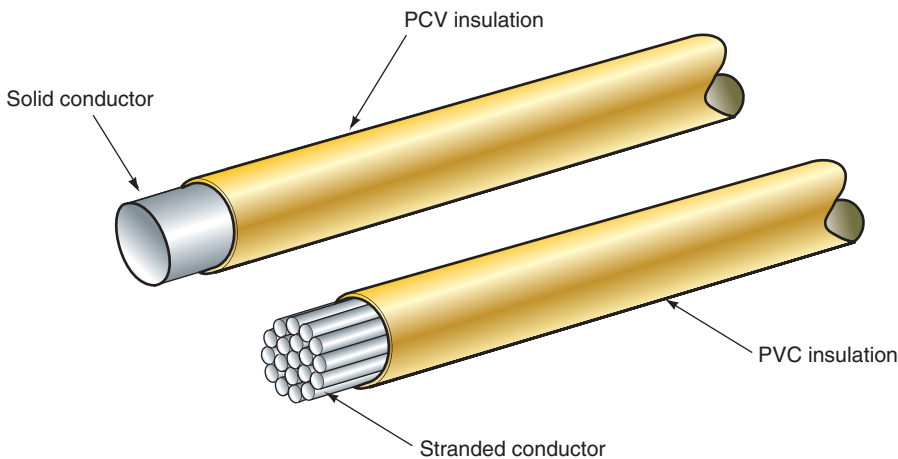
Shop Manual

Chapter 4, page 140



© Delmar/Cengage Learning

**FIGURE 4-1** Vehicle wiring harness.



© Delmar/Cengage Learning

**FIGURE 4-2** Comparison between solid and stranded primary wire.

**AUTHOR'S NOTE:** Copper is used mainly because of its low cost and availability.

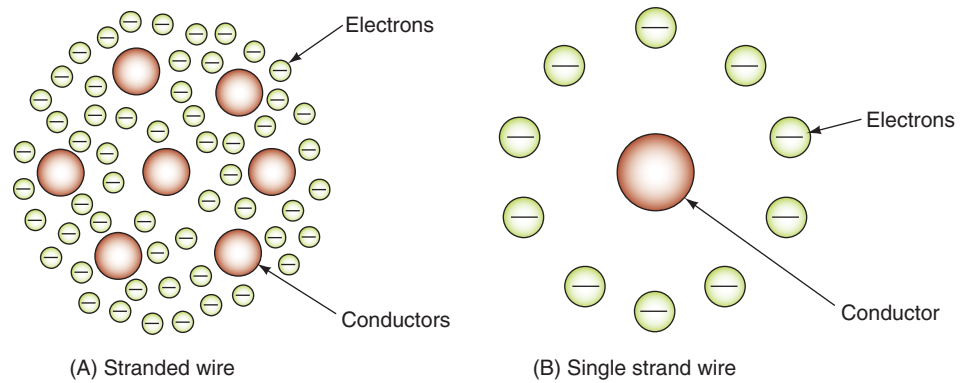
**Stranded wire** means the conductor is made of several individual wires that are wrapped together. Stranded wire is used because it is very flexible and has less resistance than solid wire. This is because electrons tend to flow on the outside surface of conductors. Since there is more surface area exposed in a stranded wire (each strand has its own surface), there is less resistance in the stranded wire than in the solid wire (Figure 4-3). The PVC insulation is used because it can withstand temperature extremes and corrosion. PVC insulation is also capable of withstanding battery acid, antifreeze, and gasoline. The insulation protects the wire from shorting to ground and from corrosion.

**AUTHOR'S NOTE:** General Motors has used single-stranded aluminum wire in limited applications where no flexing of the wire is expected. For example, it is used in the taillight circuits.

## Wire Sizes

Consideration must be given for some margin of safety when selecting wire size. There are three major factors that determine the proper size of wire to be used:





**FIGURE 4-3** Stranded wire provides flexibility and more surface area for electron flow than a single-strand solid wire.

1. The wire must have a large enough diameter, for the length required, to carry the necessary current for the load components in the circuit to operate properly.
2. The wire must be able to withstand the anticipated vibration.
3. The wire must be able to withstand the anticipated amount of heat exposure.

Wire size is based on the diameter of the conductor. The larger the diameter, the less the resistance. There are two common size standards used to designate wire size: American Wire Gauge (AWG) and metric.

The AWG standard assigns a **gauge** number to the wire based on its diameter. The higher the number, the smaller the wire diameter. For example, 20-gauge wire is smaller in diameter than 10-gauge wire (Table 4-1). Most electrical systems in the automobile use 14-, 16-, or 18-gauge wire. Some high-current circuits will also use 10- or 12-gauge wire. Most battery cables are 2-, 4-, or 6-gauge cable.

Both wire diameter and wire length affect resistance. Sixteen-gauge wire is capable of conducting 20 amperes for 10 feet with minimal voltage drop. However, if the current is to be carried for 15 feet, 14-gauge wire would be required. If 20 amperes were required to be carried for 20 feet, then 12-gauge wire would be required. The additional wire size is needed to prevent voltage drops in the wire. The illustration (Table 4-2) lists the wire size required to carry a given amount of current for different lengths.

**TABLE 4-1 GAUGE AND WIRE SIZE CHART**

American Wire Gauge Sizes	
Gauge size	Conductor diameter (inches)
20	0.032
18	0.040
16	0.051
14	0.064
12	0.081
10	0.102
8	0.128
6	0.162
4	0.204
2	0.258
1	0.289
0	0.325
2/0	0.365
4/0	0.460

**TABLE 4-2 THE DISTANCE THE CURRENT MUST BE CARRIED IS A FACTOR IN DETERMINING THE CORRECT WIRE GAUGE TO USE**

Total Approximate Circuit Amperes	Wire Gauge (for Length in Feet)								
	3	5	7	10	15	20	25	30	40
12 V									
1.0	18	18	18	18	18	18	18	18	18
1.5	18	18	18	18	18	18	18	18	18
2	18	18	18	18	18	18	18	18	18
3	18	18	18	18	18	18	18	18	18
4	18	18	18	18	18	18	18	16	16
5	18	18	18	18	18	18	18	16	16
6	18	18	18	18	18	18	16	16	16
7	18	18	18	18	18	18	16	16	14
8	18	18	18	18	18	16	16	16	14
10	18	18	18	18	16	16	16	14	12
11	18	18	18	18	16	16	14	14	12
12	18	18	18	18	16	16	14	14	12
15	18	18	18	18	14	14	12	12	12
18	18	18	16	16	14	14	12	12	10
20	18	18	16	16	14	12	10	10	10
22	18	18	16	16	12	12	10	10	10
24	18	18	16	16	12	12	10	10	10
30	18	16	16	14	10	10	10	10	10
40	18	16	14	12	10	10	8	8	6
50	16	14	12	12	10	10	8	8	6
100	12	12	10	10	6	6	4	4	4
150	10	10	8	8	4	4	2	2	2
200	10	8	8	6	4	4	2	2	1

Another factor to wire resistance is temperature. An increase in temperature creates a similar increase in resistance. A wire may have a known resistance of 0.03 ohms per 10 feet at 70°F. When exposed to temperatures of 170°F, the resistance may increase to 0.04 ohms per 10 feet. Wires that are to be installed in areas that experience high temperatures, as in the engine compartment, must be of a size such that the increased resistance will not affect the operation of the load component. Also, the insulation of the wire must be capable of withstanding the high temperatures.

In the metric system, wire size is determined by the cross-sectional area of the wire. Metric wire size is expressed in square millimeters (mm<sup>2</sup>). In this system the smaller the number, the smaller the wire conductor. The approximate equivalent wire size of metric to AWG is shown in Table 4-3.

## Ground Straps

Usually there is not a direct metal to metal connection between the powertrain components and the vehicle chassis. The engine, transmission, and axle assemblies are supported by rubber mounts or bushings. The rubber acts as an insulator so any electrical components such as actuators or sensors that are mounted to the powertrain components will not have a completed circuit back to the vehicle's battery. This is especially true if the negative battery cable is attached to the vehicle's chassis instead of the engine block. **Ground straps** between the powertrain components and the vehicle's chassis are used to complete the return path to the

**TABLE 4-3 APPROXIMATE AWG TO METRIC EQUIVALENTS**

Metric Size (mm <sup>2</sup> )	AWG (Gauge) Size	Ampere Capacity
0.5	20	4
0.8	18	6
1.0	16	8
2.0	14	15
3.0	12	20
5.0	10	30
8.0	8	40
13.0	6	50
19.0	4	60



© Delmar/Cengage Learning

**FIGURE 4-4** Ground straps are used to provide a return path for components that are insulated from the chassis.

battery (Figure 4-4). In addition, ground straps suppress electromagnetic induction (EMI) and radiation by providing a low-resistance circuit ground path.

**AUTHOR'S NOTE:** Ground straps are also referred to as bonding straps.

Ground straps can be installed in various locations. Some of the most common locations are:

- Engine to bulkhead or fender.
- Across the engine mounts.
- Radio chassis to instrument panel frame.
- Air-conditioning evaporator valve to the bulkhead.

The ground strap can be a large gauge insulated-type cable or a braided strap. Even on vehicles with the battery negative cable attached to the engine block, ground straps are used to connect between the engine block and the vehicle chassis. The additional ground cable ensures a good, low-resistance ground path between the engine and the chassis.

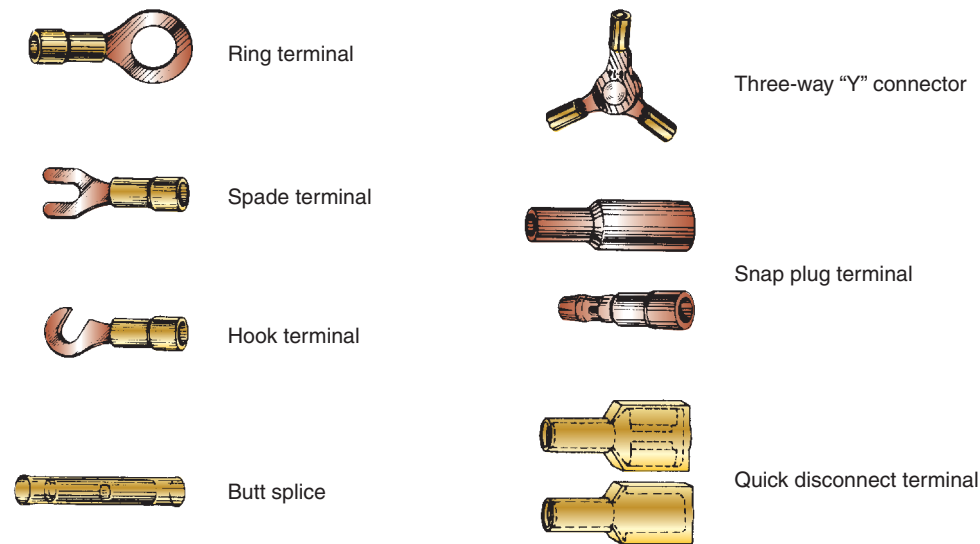
Ground straps are also used to connect sheet metal parts such as the hood, fender panels, and the exhaust system even though there is no electrical circuit involved. In these cases, the strap is used to suppress EMI since the sheet metal could behave as a large capacitor. The air space between the sheet metal forms an electrostatic field and can interfere with any computer-controlled circuits that are routed near the sheet metal.

## Terminals and Connectors

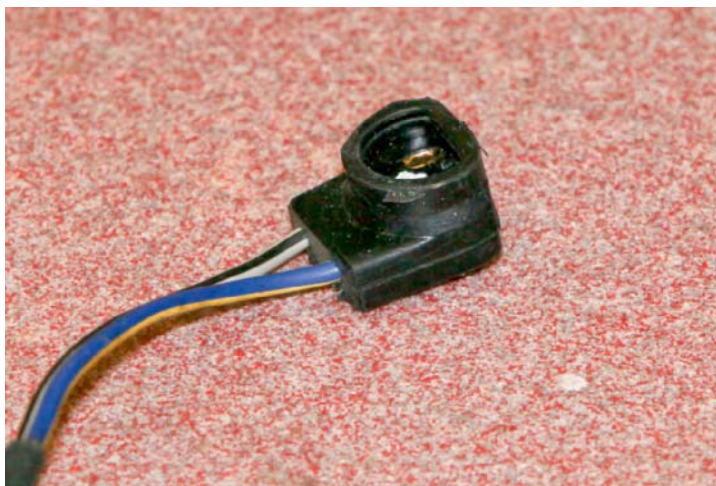
To perform the function of connecting the wires from the voltage source to the load component reliably, terminal connections are used. Today's vehicles can have as many as 500 separate circuit connections. The terminals used to make these connections must be able to perform with very low voltage drop. Terminals are constructed of either brass or steel. Steel terminals usually have a tin or lead coating. A loose or corroded connection can cause an unwanted voltage drop that results in poor operation of the load component. For example, a connector used in a light circuit that has as little as 10% voltage drop (1.2 V) may result in a 30% loss of lighting efficiency.

Terminals can be either crimped or soldered to the conductor. The terminal makes the electrical connection, and it must be capable of withstanding the stress of normal vibration. The illustration (Figure 4-5) shows several different types of terminals used in the automotive electrical system. In addition, the following connectors are used on the automobile:

- 1. Molded connector:** These connectors usually have one to four wires that are molded into a one-piece component (Figure 4-6). Although the connector halves separate, the connector itself cannot be taken apart.



**FIGURE 4-5** Examples of primary wire terminals and connectors used in automotive applications.



**FIGURE 4-6** Molded connectors cannot be disassembled to replace damaged terminals or to test.

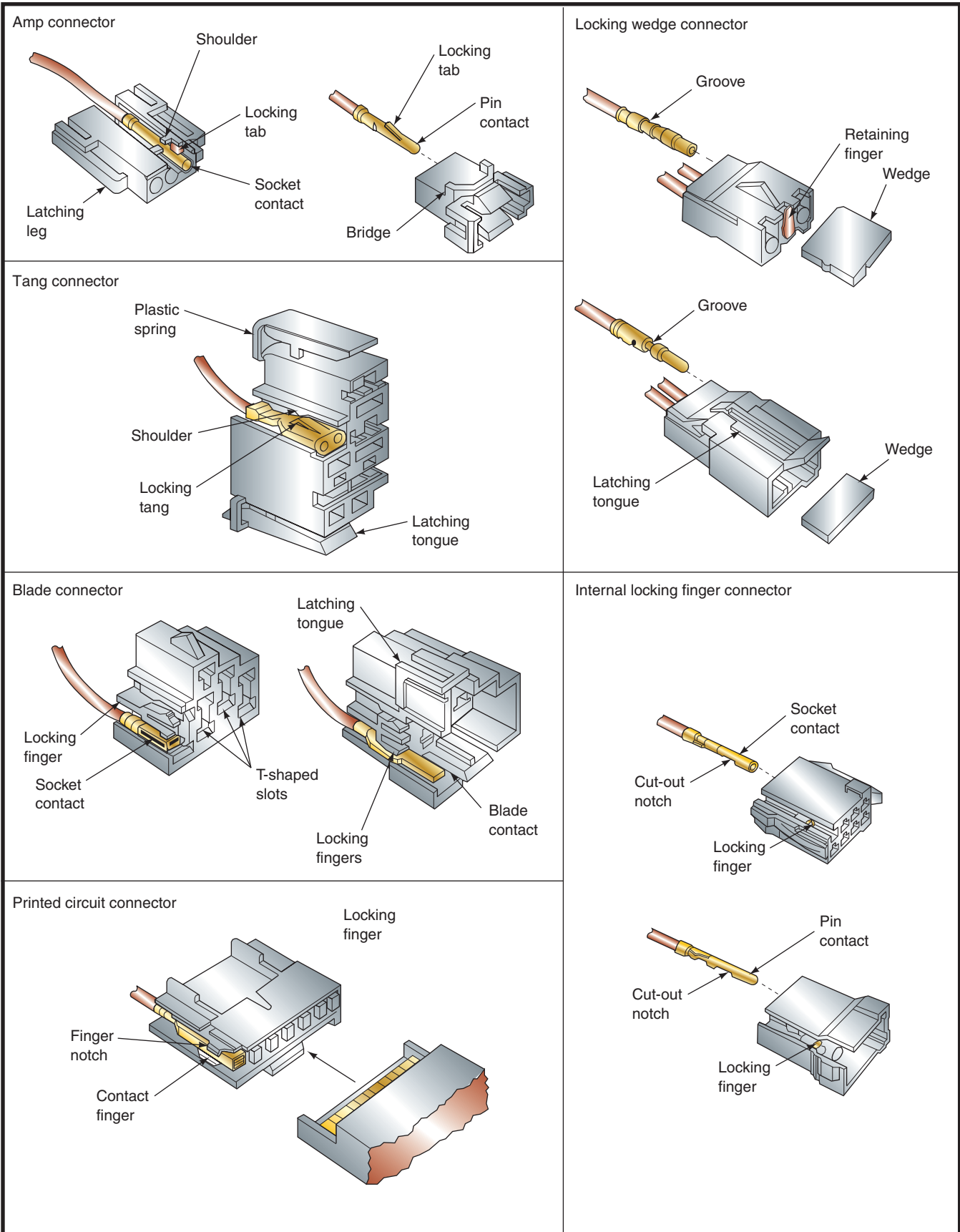


FIGURE 4-7 Multiple-wire hard-shell connectors.



2. **Multiple-wire, hard-shell connector:** These connectors usually have a hard, plastic shell that holds the connecting terminals of separate wires (Figure 4-7). The wire terminals can be removed from the shell to be repaired.
3. **Bulkhead connectors:** These connectors are used when several wires must pass through the bulkhead (Figure 4-8).
4. **Weather-Pack Connectors:** These connectors have rubber seals on the terminal ends and on the covers of the connector half (Figure 4-9). They are used on computer circuits to protect the circuit from corrosion, which may result in a voltage drop.
5. **Metri-Pack Connectors:** These are like the weather-pack connectors but do not have the seal on the cover half (Figure 4-10).
6. **Heat Shrink Covered Butt Connectors:** Recommended for air bag applications by some manufacturers. Other manufacturers allow NO repairs to the circuitry, while still others require silver-soldered connections.

To reduce the number of connectors in the electrical system, a **common connection** can be used (Figure 4-11). Common connections are used to share a source of power or a common ground and are often called a splice. If there are several electrical components that are physically close to each other, a single common connection (splice) eliminates using a separate connector for each wire.

**Shop Manual**  
Chapter 4, page 150

**Shop Manual**  
Chapter 4, page 151

**Shop Manual**  
Chapter 4, page 152



© Delmar/Cengage Learning

**FIGURE 4-8** Bulkhead connector.



© Delmar/Cengage Learning

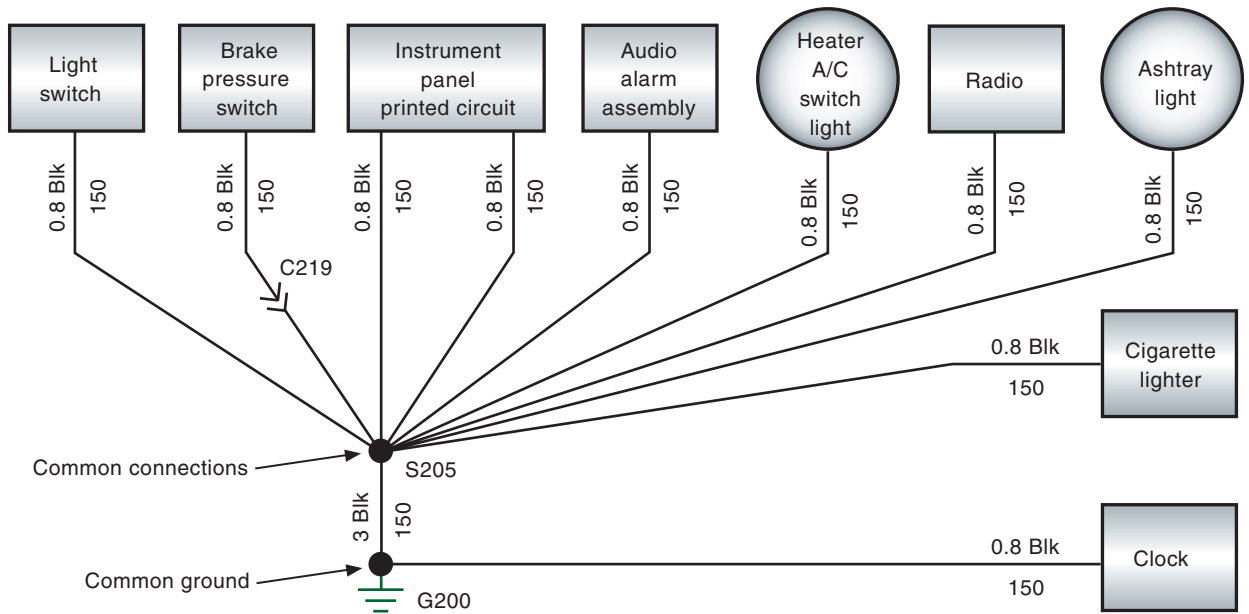
**FIGURE 4-9** Weather-pack connector is used to prevent connector corrosion.



© Delmar/Cengage Learning

**FIGURE 4-10** Metri-pack connector.

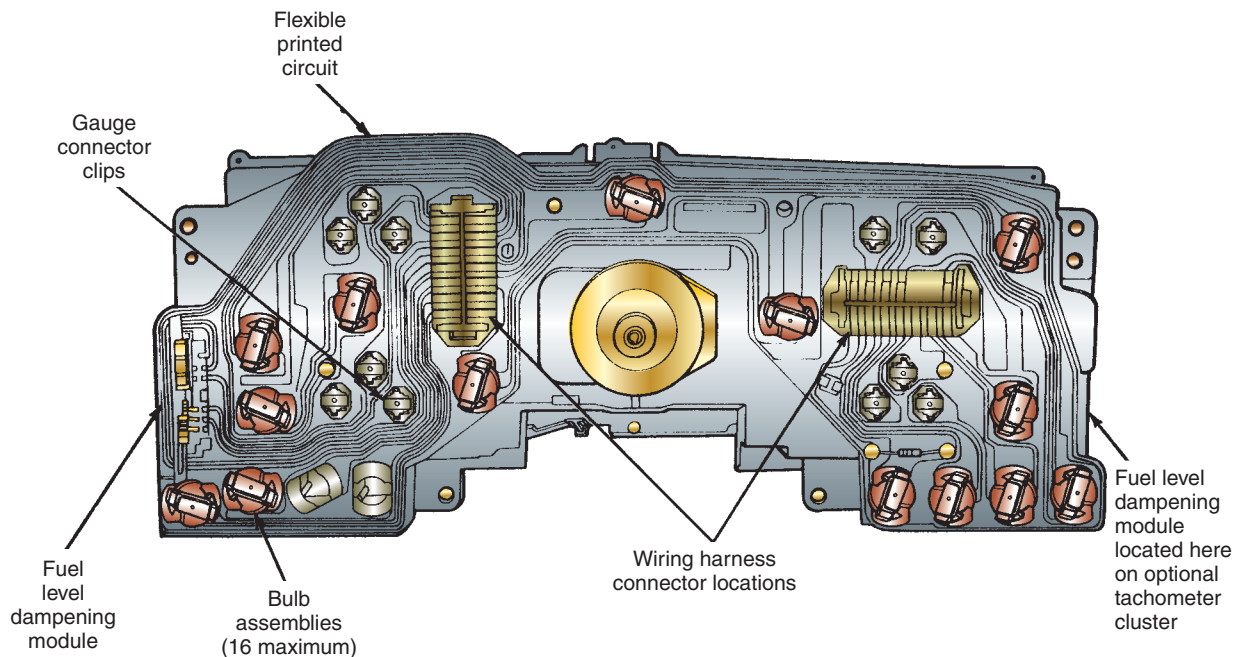




**FIGURE 4-11** Common connections (splices) are used to reduce the amount of wire and connectors.

## Printed Circuits

**Printed circuit boards** are used to simplify the wiring of the circuits they operate. Other uses of printed circuit boards include the inside of radios, computers, and some voltage regulators. Most instrument panels use printed circuit boards as circuit conductors. A printed circuit is made of a thin phenolic or fiberglass board that copper (or some other conductive material) has been deposited on. Portions of the conductive metal are then etched or eaten away by acid. The remaining strips of conductors provide the circuit path for the instrument panel illumination lights, warning lights, indicator lights, and gauges of the instrument panel (Figure 4-12). The printed circuit board is attached to the back of the instrument panel housing. An edge connector joins the printed circuit board to the vehicle wiring harness.



**FIGURE 4-12** Printed circuits eliminate bulky wires behind the instrument panel.

Whenever it is necessary to perform repairs on or around the printed circuit board, it is important to follow these precautions:

1. When replacing light bulbs, be careful not to cut or tear the surface of the printed circuit board.
2. Do not touch the surface of the printed circuit with your fingers. The acid present in normal body oils can damage the surface.
3. If the printed circuit board needs to be cleaned, use a commercial cleaning solution designed for electrical use. If this solution is not available, it is possible to clean the board by *lightly* rubbing the surface with an eraser.



## A BIT OF HISTORY

The printed circuit board was developed in 1947 by the British scientist J. A. Sargrove to simplify the production of radios.

## Wiring Harness

Most manufacturers use **wiring harnesses** to reduce the number of loose wires hanging under the hood or dash of an automobile. The wiring harness provides for a safe path for the wires of the vehicle's lighting, engine, and accessory components. The wiring harness is made by grouping insulated wires and wrapping them together. The wires are bundled into separate harness assemblies that are joined together by connector plugs. The multiple-pin connector plug may have more than 60 individual wire terminals.

There are several complex wiring harnesses in a vehicle, in addition to the simple harnesses. The engine compartment harness and the under-dash harness are examples of complex harnesses (Figure 4-13). Lighting circuits usually use a more simple harness

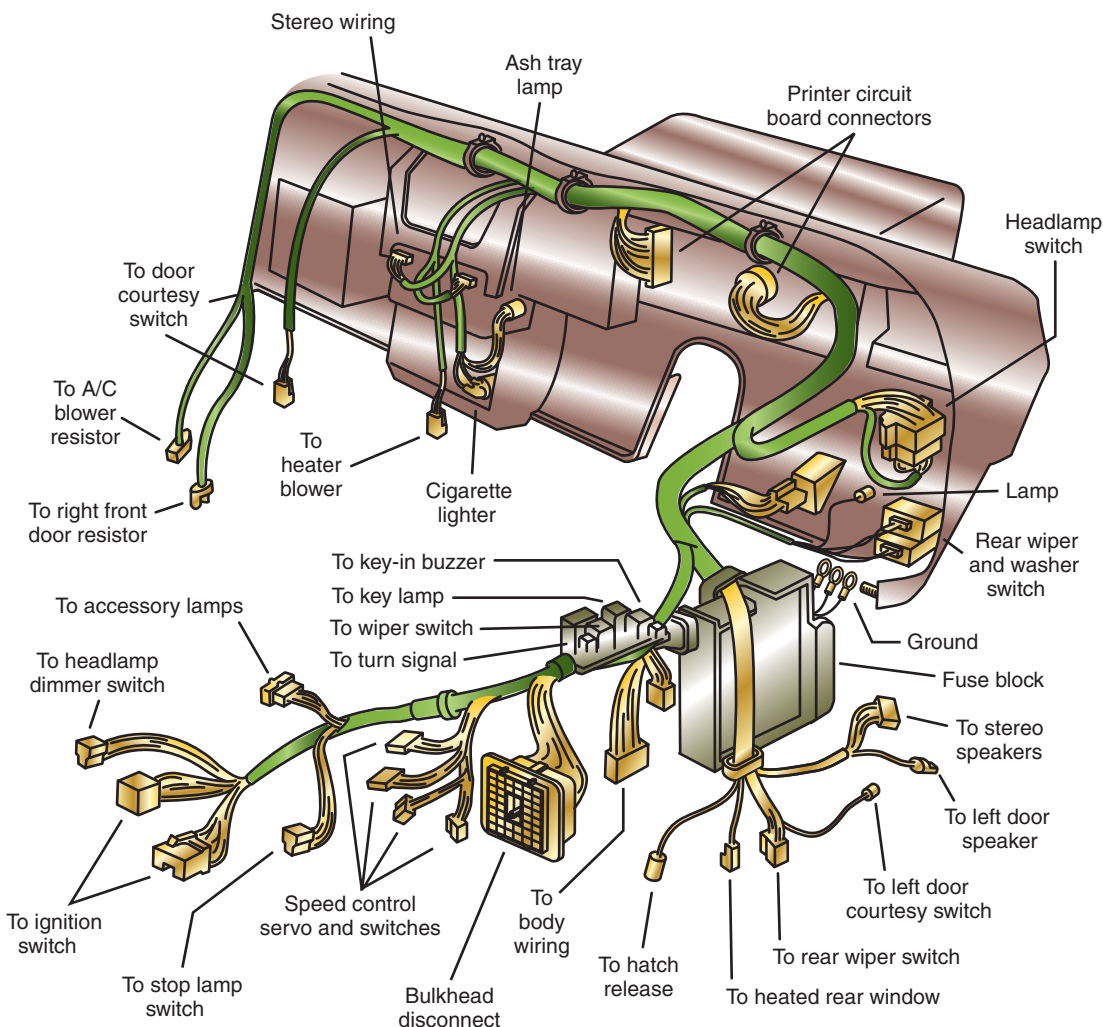
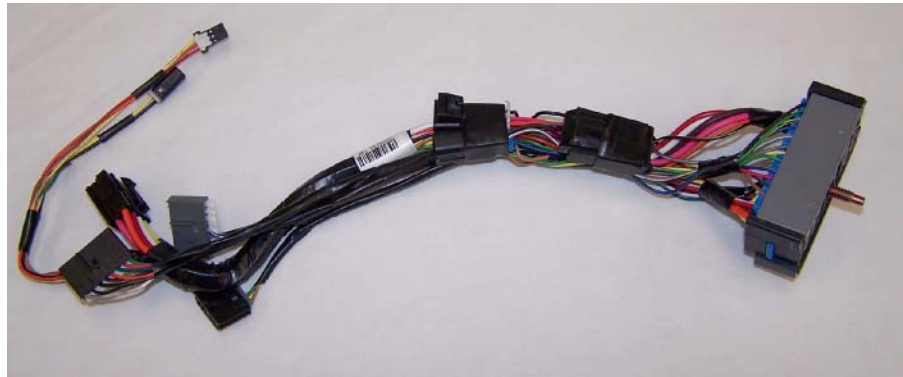


FIGURE 4-13 Complex wiring harness.

© Delmar/Cengage Learning



© Delmar/Cengage Learning

**FIGURE 4-14** Simple wiring harness.



© Delmar/Cengage Learning

**FIGURE 4-15** Flexible conduit used to make wiring harnesses.

The conduit is commonly referred to as the *wire loom* or *corrugated loom*.

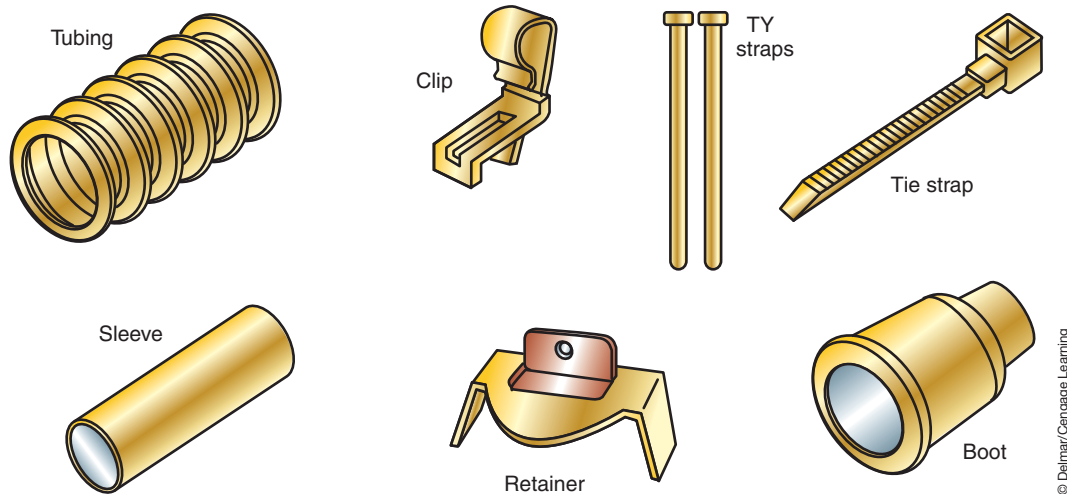
(Figure 4-14). A complex harness serves many circuits. The simple harness services only a few circuits. Some individual circuit wires may branch out of a complex harness to other areas of the vehicle.

Most wiring harnesses now use a flexible conduit to provide for quick wire installation (Figure 4-15). The conduit has a seam that can be opened to accommodate the installation or removal of wires from the harness. The seam will close once the wires are installed, and will remain closed even if the conduit is bent.

## Wiring Protective Devices

Often overlooked, but very important to the electrical system, are proper wire protection devices (Figure 4-16). These devices prevent damage to the wiring by maintaining proper wire routing and retention. Special clips, retainers, straps, and supplementary insulators provide additional protection to the conductor over what the insulation itself is capable of providing. Whenever the technician must remove one of these devices to perform a repair, it is important that the device be reinstalled to prevent additional electrical problems.

Whenever it is necessary to install additional electrical accessories, try to support the primary wire in at least 1-foot intervals. If the wire must be routed through the frame or body, use rubber grommets to protect the wire.



**FIGURE 4-16** Typical wire protection devices.

© Delmar/Cengage Learning

## WIRING DIAGRAMS

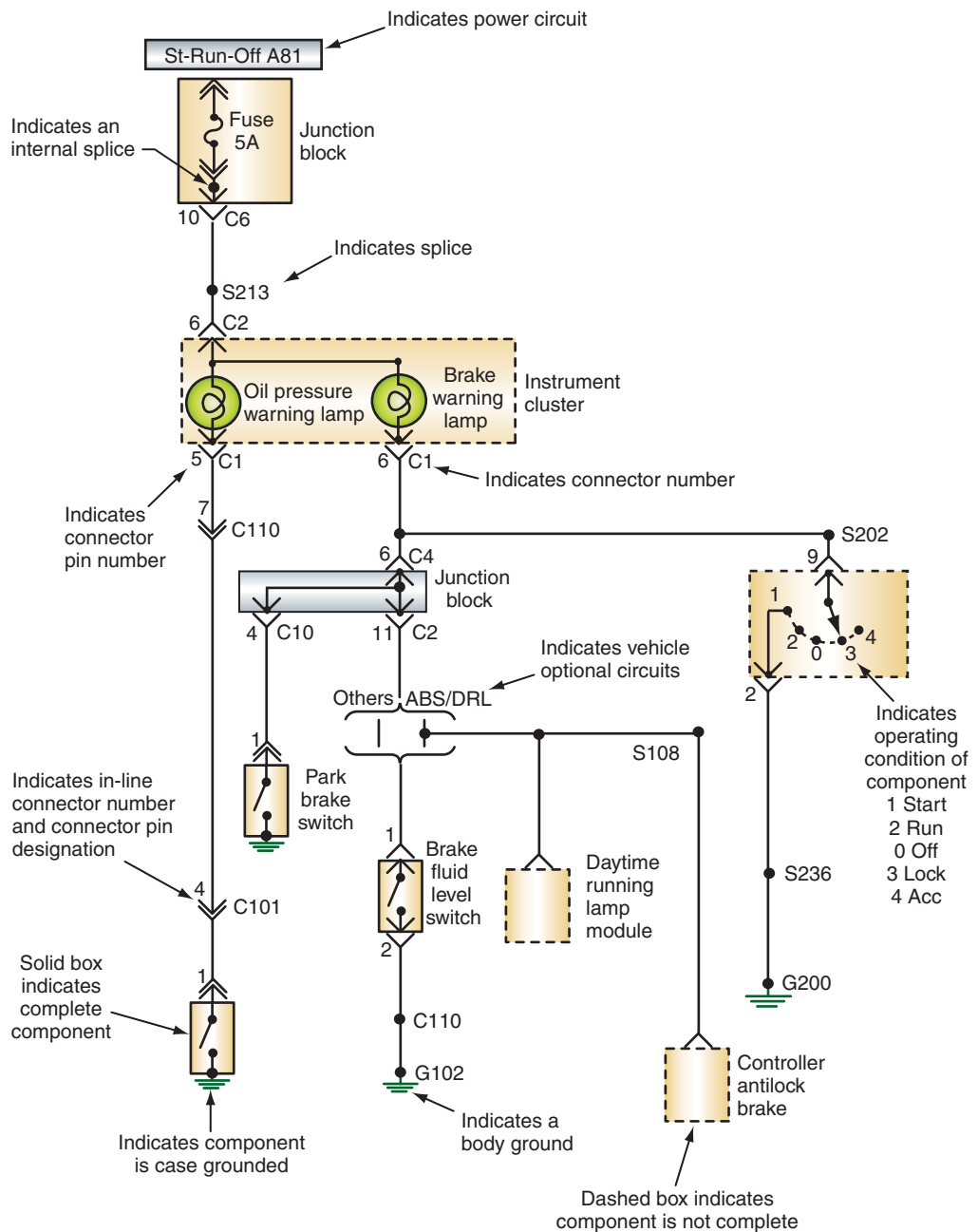
One of the most important tools for diagnosing and repairing electrical problems is a **wiring diagram**. A wiring diagram is an electrical schematic that shows a representation of actual electrical or electronic components (by use of symbols) and the wiring of the vehicle's electrical systems. These diagrams identify the wires and connectors from each circuit on a vehicle. They also show where different circuits are interconnected, where they receive their power, where the ground is located, and the colors of the different wires. All of this information is critical to proper diagnosis of electrical problems. Some wiring diagrams also give additional information that helps you understand how a circuit operates and how to identify certain components (Figure 4-17). Wiring diagrams do not explain how the circuit works; this is where your knowledge of electricity comes in handy.

A wiring diagram can show the wiring of the entire vehicle or a single circuit (Figure 4-18). These single-circuit diagrams are also called block diagrams. Wiring diagrams of the entire vehicle tend to look more complex and threatening than block diagrams. However, once you simplify the diagram to only those wires, connectors, and components that belong to an individual circuit, they become less complex and more valuable.

Wiring diagrams show the wires, connections to switches and other components, and the type of connector used throughout the circuit. Total vehicle wiring diagrams are normally spread out over many pages of a service information. Some are displayed on a single large sheet of paper that folds out of the manual. A system wiring diagram is actually a portion of the total vehicle diagram. The system and all related circuitry are shown on a single page. System diagrams are often easier to use than vehicle diagrams simply because there is less information to sort through.

Remember that electrical circuits need a complete path in order to work. A wiring diagram shows the insulated side of the circuit and the point of ground. Also, when lines (or wires) cross on a wiring diagram, this does not mean they connect. If wires are connected, there will be a connector or a dot at the point where they cross. Most wiring diagrams do not show the location of the wires, connectors, or components in the vehicle. Some have location reference numbers displayed by the wires. After studying the wiring diagram, you will know what you are looking for. Then you move to the car to find it.

In addition to entire vehicle and system-specific wiring diagrams, there are other diagrams that may be used to diagnose electricity problems. An electrical **schematic** shows how

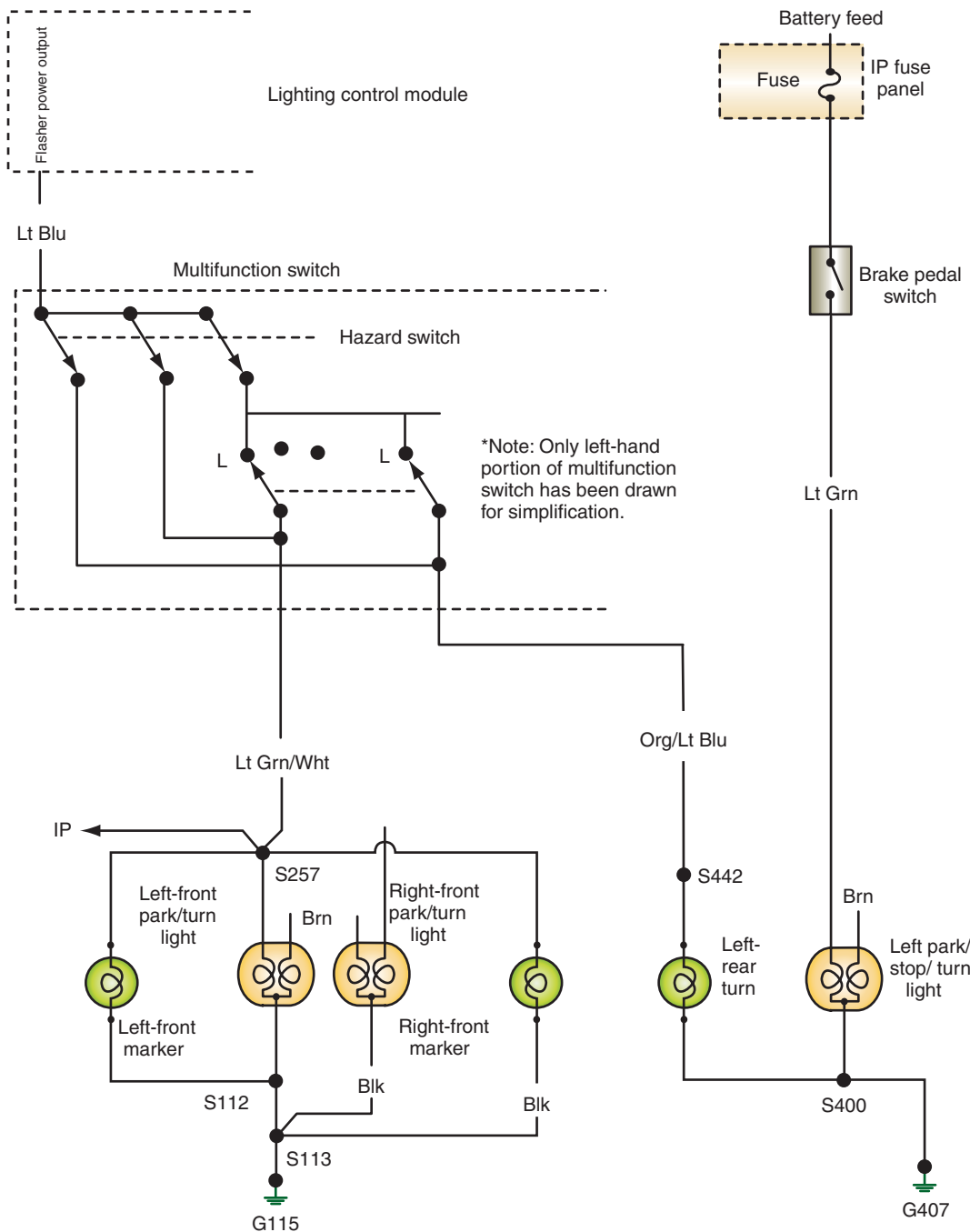


**FIGURE 4-17** Wiring diagrams provide the technician with necessary information to accurately diagnose the electrical systems.

the circuit is connected. It does not show the colors of the wires or their routing. Schematics are what have been used so far in this book. They display a working model of the circuit. These are especially handy when trying to understand how a circuit works. Schematics are typically used to show the internal circuitry of a component or to simplify a wiring diagram. One of the troubleshooting techniques used by good electrical technicians is to simplify a wiring diagram into a schematic.

## Electrical Symbols

Most wiring diagrams do not show an actual drawing of the components. Rather, they use **electrical symbols** to represent the components. Often the symbol displays the basic operation of the component. Many different symbols have been used in wiring diagrams



© Delmar/Cengage Learning



## A BIT OF HISTORY

The service manuals for early automobiles were hand drawn and labeled. They also had drawings of the actual components. As more and more electrical components were added to cars, this became impractical. Soon schematic symbols replaced the component drawings.

**FIGURE 4-18** Wiring diagram illustrating only one specific circuit for easier reference. This is also known as a block diagram.

through the years. Table 4-4 shows some of the commonly used symbols. You need to be familiar with all of the symbols; however, you don't need to memorize all of the variations. Wiring diagram manuals include a "legend" that helps you interpret the symbols.

## Color Codes and Circuit Numbering

Nearly all of the wires in an automobile are covered with colored insulation. These colors are used to identify wires and electrical circuits. The color of the wires is indicated on a wiring diagram. Some wiring diagrams also include circuit numbers. These numbers, or letters and numbers, help identify a specific circuit. Both types of coding make it easier to diagnose electrical problems. Unfortunately, not all manufacturers use the same method of wire



TABLE 4-4 COMMON ELECTRICAL AND ELECTRONIC SYMBOLS USED IN WIRING DIAGRAMS

COMPONENT	SYMBOL	ALTERNATE
Ammeter		
And Gate		
Antenna		
Attenuator, Fixed		
Attenuator, Variable		
Battery		
Capacitor, Feedthrough		
Capacitor, Fixed, Nonpolarized		
Capacitor, Fixed, Polarized		
Capacitor, Ganged, Variable		
Capacitor, General		
Capacitor, Variable, Single		
Capacitor, Variable, Split-Stator		
Cathode, Cold		
Cathode, Directly Heated		
Cathode, Indirectly Heated		
Cavity Resonator		
Cell		
Choice Bracket		
Circuit Breaker or PTC device		
Clockspring		
Coaxial Cable		
Coil		
Crystal, Piezoelectric		
Delay Line		
Diode		
Diode, Gunn		
Diode, Light-Emitting		
Diode, Photosensitive		
Diode, Photovoltaic		

TABLE 4-4 (continued)

Diode, Pin		
Diode, Varactor		
Diode, Zener		
Directional Coupler		
Dual Filament Lamp		
Exclusive-Or Gate		
Female Contact		
Ferrite Bead		
Fuse		
Fusible link		
Gauge		
Ground, Chassis		
Ground, Earth		
Handset		
Headphone, Double		
Headphone, Single		
Heating element		
Hot Bar		
Inductor, Air-Core		
Inductor, Bifilar		
Inductor, Iron-Core		
Inductor, Tapped		
Inductor, Variable		
In-Line Connectors		
Integrated Circuit		
Inverter		
Jack, Coaxial		
Jack, Phone, 2-Conductor		
Jack, Phone, 2-Conductor Interrupting		
Jack, Phone, 3-Conductor		
Jack, Phono		

TABLE 4-4 (continued)

Key, Telegraph		
Lamp, Neon		
Male Contact		
Microphone		
Motor, One speed		
Motor, Reversible		
Motor, two Speed		
Multiple connectors		
Nand Gate		
Negative Voltage Connection		
Nor Gate		
Operational Amplifier		
Or Gate		
Outlet, Utility, 117-V		
Outlet, Utility, 234-V		
Oxygen Sensor		
Page Reference	(BW-30-10)	
Piezoelectric Cell		
Photocell, Tube		
Plug, Phone, 2-Conductor		
Plug, Phone, 3-Conductor		
Plug, Phono		
Plug, Utility, 117-V		
Plug, Utility, 234-V		
Positive Voltage Connection		
Potentiometer		
Probe, Radio-Frequency		
Rectifier, Semiconductor		
Rectifier, Silicon-Controlled		
Rectifier, Tube-Type		
Relay, DPDT		

TABLE 4-4 (continued)

Relay, DPST		
Relay, SPDT		
Relay, SPST		
Resistor		
Resonator		
Rheostat, Variable Resistor, Thermistor		
Saturable Reactor		
Shielding		
Signal Generator		
Single Filament Lamp		
Sliding Door Contact		
Solenoid		
Solenoid Valve		
Speaker		
Splice, External		
Splice, Internal		
Splice, Internal (Incompleted)		
Switch, Closed		
Switch, DPDT		
Switch, DPST		
Switch, Ganged		
Switch, Momentary-Contact		
Switch, Open		
Switch, Resistive Multiplex		
Switch, Rotary		
Switch, SPDT		
Switch, SPST		
Terminals		
Test Point		
Thermocouple		

TABLE 4-4 (continued)

Thyristor		
Tone Generator		
Transformer, Air-Core		
Transformer, Iron-Core		
Transformer, Tapped Primary		
Transformer, Tapped Secondary		
Transistor, Bipolar, npn		
Transistor, Bipolar, pnp		
Transistor, Field-Effect, N-Channel		
Transistor, Field-Effect, P-Channel		
Transistor, Metal-Oxide, Dual-Gate		
Transistor, Metal-Oxide, Single-Gate		
Transistor, Photosensitive		
Transistor, Unijunction		
Tube, Diode		
Tube, Pentode		
Tube, Photomultiplier		
Tube, Tetrode		
Tube, Triode		
Unspecified Component		
Voltmeter		
Wattmeter		
Wire Destination In Another Cell		
Wire Origin & Destination Within Cell		
Wires		
Wires, Connected, Crossing		
Wires, Not Connected, Crossing		

**TABLE 4-5 COMMON COLOR CODES USED IN AUTOMOTIVE APPLICATIONS**

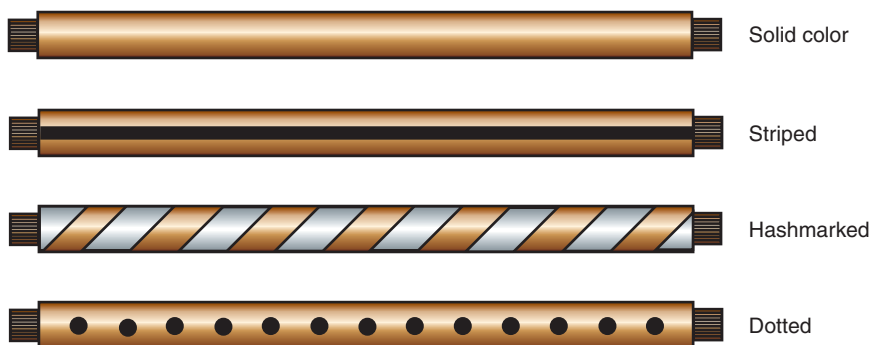
Color	Abbreviations		
Black	BLK	BK	B
Blue (Dark)	BLU DK	DB	DK BLU
Blue	BLU	B	L
Blue (Light)	BLU LT	LB	LT BLU
Brown	BRN	BR	BN
Glazed	GLZ	GL	
Gray	GR A	GR	G
Green (Dark)	GRN DK	DG	DK GRN
Green (Light)	GRN LT	LG	LT GRN
Maroon	MAR	M	
Natural	NAT	N	
Orange	ORN	O	ORG
Pink	PNK	PK	P
Purple	PPL	PR	
Red	RED	R	RD
Tan	TAN	T	TN
Violet	VLT	V	
White	WHT	W	WH
Yellow	YEL	Y	YL

identification. Table 4-5 shows common color codes and their abbreviations. Most wiring diagrams list the appropriate color coding used by the manufacturer. Make sure you understand what color the code is referring to before looking for a wire.

In most color codes, the first group of letters designates the base color of the insulation. If a second group of letters is used, it indicates the color of the **tracer**. For example, a wire designated as WH/BLK would have a white base color with a black tracer. A tracer is a thin or dashed line of a different color than the base color of the insulation.

Ford uses four methods of color coding its wires (Figure 4-19):

1. Solid color.
2. Base color with a stripe (tracer).
3. Base color with hash marks.
4. Base color with dots.

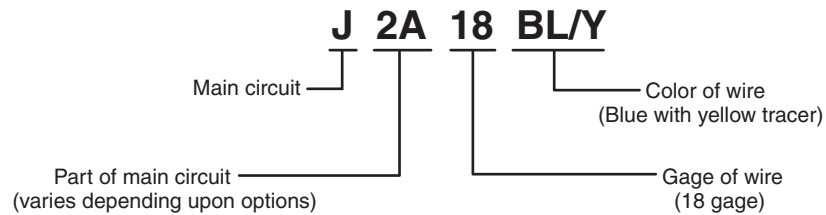


Examples	
BK	Solid black
BR-Y	Brown with yellow stripe
BK-YH	Black with yellow hashmarks
O-BK D	Orange with black dots

**FIGURE 4-19** Four methods that Ford uses to color code their wires.

© Delmar/Cengage Learning





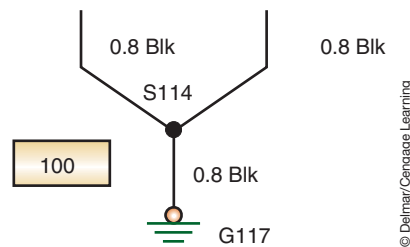
**FIGURE 4-20** Chrysler's wiring code identification.

Chrysler uses a numbering method to designate the circuits on the wiring diagram (Figure 4-20). The circuit identification, wire gauge, and color of the wire are included in the wire number. Chrysler identifies the main circuits by using a main circuit identification code that corresponds to the first letter in the wire number (Table 4-6).

General Motors uses numbers that include the wire gauge in metric millimeters, the wire color, the circuit number, splice number, and ground identification (Figure 4-21). In this example, the circuit is designated as 100, the wire size is 0.8 mm<sup>2</sup>, the insulation color is black, the splice is numbered S114, and the ground is designated as G117.

Most manufacturers also number connectors, terminals, splices, and grounds for identification. The numbers correspond to their general location within the vehicle. The following is typical identification numbers:

100-199	Engine compartment forward of the dash panel
200-299	Instrument panel area
300-399	Passenger compartment
400-499	Deck area
500-599	Left front door
600-699	Right front door
700-799	Left rear door
800-899	Right rear door
900-999	Deck lid or hatch



**FIGURE 4-21** GM's method of circuit and wire identification.

**TABLE 4-6 CHRYSLER'S CIRCUIT IDENTIFICATION CODES**

<b>CIRCUIT IDENTIFICATION CODE CHART</b>	
<b>CIRCUIT</b>	<b>FUNCTION</b>
A	BATTERY FEED
B	BRAKE CONTROLS
C	CLIMATE CONTROLS
D	DIAGNOSTIC CIRCUITS
E	DIMMING ILLUMINATION CIRCUITS
F	FUSED CIRCUITS
G	MONITORING CIRCUITS (GAUGES)
H	MULTIPLE
I	NOT USED
J	OPEN
K	POWERTRAIN CONTROL MODULE
L	EXTERIOR LIGHTING
M	INTERIOR LIGHTING
N	MULTIPLE
O	NOT USED
P	POWER OPTION (BATTERY FEED)
Q	POWER OPTIONS (IGNITION FEED)
R	PASSIVE RESTRAINT
S	SUSPENSION/STEERING
T	TRANSMISSION/TRANSAXLE/TRANSFER CASE
U	OPEN
V	SPEED CONTROL, WIPER/WASHER
W	WIPERS
X	AUDIO SYSTEMS
Y	TEMPORARY
Z	GROUNDS

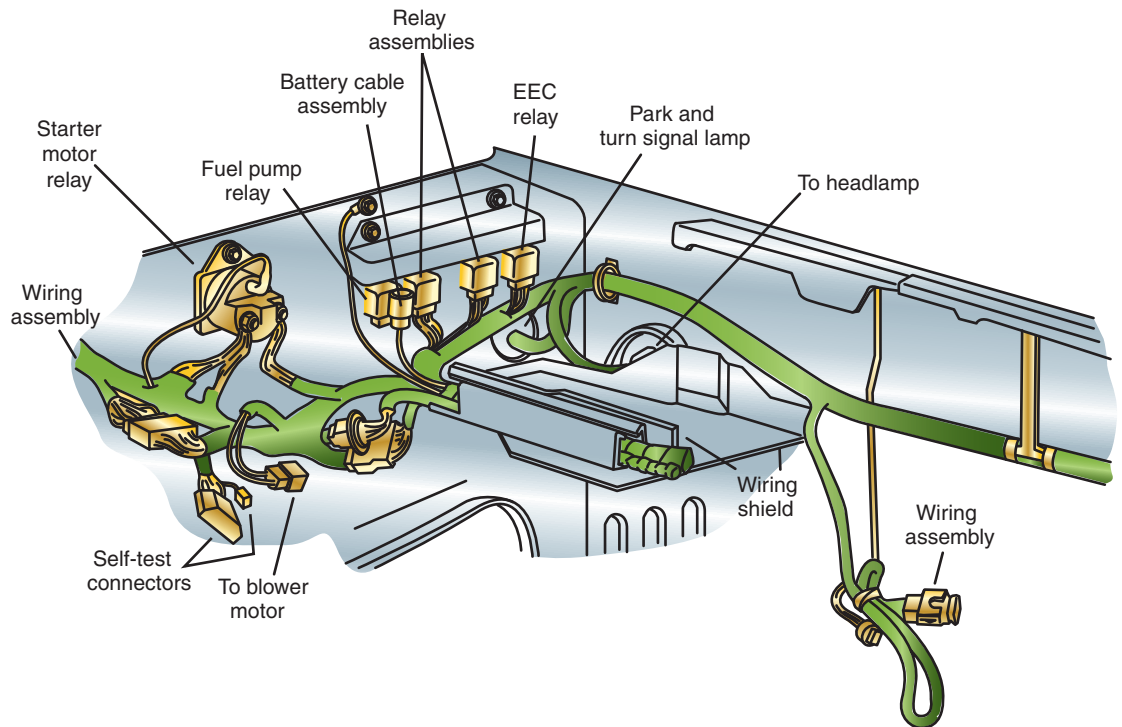


FIGURE 4-22 A typical installation diagram.

© Delmar/Cengage Learning

Component locators are also called installation diagrams

## Component Locators

The wiring diagrams in most service informations may not indicate the exact physical location of the components of the circuit. In another section of the service information, or in a separate manual, a **component locator** is provided to help find where a component is installed in the vehicle. The component locator may use both drawings and text to lead the technician to the desired component (Figure 4-22).

Many electrical components may be hidden behind kick panels, dashboards, fender wells, and under seats. The use of a component locator will save the technician time in finding the suspected defective unit.

## SUMMARY

- Most of the primary wiring conductors used in the automobile are made of several strands of copper wire wound together and covered with a polyvinyl chloride (PVC) insulation.
- Stranded wire is used because of its flexibility and current flows on the surface of the conductors. Because there is more surface area exposed in a stranded wire, there is less resistance in the stranded wire than in the solid wire.
- There are three major factors that determine the proper size of wire to be used: (1) The wire must be large enough diameter—for the length required—to carry the necessary current for the load components in the circuit to operate properly, (2) the wire must be able to withstand the anticipated vibration, and (3) the wire must be able to withstand the anticipated amount of heat exposure.
- Wire size is based on the diameter of the conductor.

## SUMMARY

---

- Factors that affect the resistance of the wire include the conductor material, wire diameter, wire length, and temperature.
- Ground straps are used to complete the return path to the battery between components that are insulated. They are also used to suppress electromagnetic induction (EMI) and radiation.
- Terminals can be either crimped or soldered to the conductor. The terminal makes the electrical connection and it must be capable of withstanding the stress of normal vibration.
- Printed circuit boards are used to simplify the wiring of the circuits they operate. A printed circuit is made of a thin phenolic or fiberglass board that copper (or some other conductive material) has been deposited on.
- A wire harness is an assembled group of wires that branch out to the various electrical components. It is used to reduce the number of loose wires hanging under the hood or dash. It provides for a safe path for the wires of the vehicle's lighting, engine, and accessory components.
- The wiring harness is made by grouping insulated wires and wrapping them together. The wires are bundled into separate harness assemblies that are joined together by connector plugs.
- A wiring diagram shows a representation of actual electrical or electronic components and the wiring of the vehicle's electrical systems.
- The technician's greatest helpmate in locating electrical problems is the wiring diagram. Correct use of the wiring diagram will reduce the amount of time a technician needs to spend tracing the wires in the vehicle.
- In place of actual pictures, a variety of electrical symbols are used to represent the components in the wiring diagram.
- Color codes and circuit numbers are used to make tracing wires easier.
- In most color codes, the first group of letters designates the base color of the insulation. If a second group of letters is used, it indicates the color of the tracer.
- A component locator is used to determine the exact location of several of the electrical components.

## TERMS TO KNOW

Common connection  
Component locator  
DIN  
Electrical symbols  
Gauge  
Ground straps  
Installation diagrams  
Primary wiring  
Printed circuit boards  
Schematic  
Secondary wiring  
Stranded wire  
Tracer  
Wiring harness  
Wiring diagram

## REVIEW QUESTIONS

---

### Short-Answer Essays

1. Explain the purpose of wiring diagrams.
2. Explain how wire size is determined by the American Wire Gauge (AWG) and metric methods.
3. Explain the purpose and use of printed circuits.
4. Explain the purpose of the component locator.
5. Explain when single-stranded or multistranded wire should be used.
6. Explain how temperature affects resistance and wire size selection.
7. List the three major factors that determine the proper size of wire to be used.
8. List and describe the different types of terminal connectors used in the automotive electrical system.
9. What is the difference between a complex and a simple wiring harness?
10. Describe the methods the three domestic automobile manufacturers use for wiring code identification.

### Fill in the Blanks

1. There is \_\_\_\_\_ resistance in the stranded wire than in the solid wire.
2. \_\_\_\_\_ complete the return path to the battery between components that are insulated.

3. Wire size is based on the \_\_\_\_\_ of the conductor.
4. In the AWG standard, the \_\_\_\_\_ the number, the smaller the wire \_\_\_\_\_.
5. An increase in temperature creates a similar \_\_\_\_\_ in resistance.
6. \_\_\_\_\_ connectors are used when several wires must pass through the bulkhead.
7. \_\_\_\_\_ are used to prevent damage to the wiring by maintaining proper wire routing and retention.
8. A wiring diagram is an electrical schematic that shows a \_\_\_\_\_ of actual electrical or electronic components (by use of symbols) and the \_\_\_\_\_ of the vehicle's electrical systems.
9. In most color codes, the first group of letters designates the \_\_\_\_\_ of the insulation. The second group of letters indicates the color of the \_\_\_\_\_.
10. A \_\_\_\_\_ is used to determine the exact location of several of the electrical components.

## MULTIPLE CHOICE

1. Automotive wiring is being discussed.  
*Technician A* says most primary wiring is made of several strands of copper wire wound together and covered with an insulation.  
*Technician B* says the types of conductor materials used in automobiles include copper, silver, gold, aluminum, and tin-plated brass.  
 Who is correct?  
 A. A only                      C. Both A and B  
 B. B only                      D. Neither A nor B
2. Stranded wire use is being discussed.  
*Technician A* says there is less exposed surface area for electron flow in a stranded wire.  
*Technician B* says there is more resistance in the stranded wire than in the same gauge solid wire.  
 Who is correct?  
 A. A only                      C. Both A and B  
 B. B only                      D. Neither A nor B
3. A Chrysler wiring diagram designation of M2 14 BK/YL identifies the main circuit as being:  
 A. Climate control  
 B. Interior lighting  
 C. Wipers  
 D. None of the above
4. Ground straps are used to:  
 A. Provide a return path to the battery between insulated components  
 B. Suppress electromagnetic induction  
 C. Both A and B  
 D. Neither A nor B
5. The selection of the proper size of wire to be used is being discussed.  
*Technician A* says the wire must be large enough, for the length required, to carry the amount of current necessary for the load components in the circuit to operate properly.  
*Technician B* says temperature has little effect on resistance and it is not a factor in wire size selection.  
 Who is correct?  
 A. A only                      C. Both A and B  
 B. B only                      D. Neither A nor B
6. Terminal connectors are being discussed.  
*Technician A* says good terminal connections will resist corrosion.  
*Technician B* says the terminals can be either crimped or soldered to the conductor.  
 Who is correct?  
 A. A only                      C. Both A and B  
 B. B only                      D. Neither A nor B
7. Wire routing is being discussed.  
*Technician A* says to install additional electrical accessories it is necessary to support the primary wire in at least 10-foot intervals.  
*Technician B* says if the wire must be routed through the frame or body, use metal clips to protect the wire.  
 Who is correct?  
 A. A only                      C. Both A and B  
 B. B only                      D. Neither A nor B

8. Printed circuit boards are being discussed.

*Technician A* says printed circuit boards are used to simplify the wiring of the circuits they operate.

*Technician B* says care must be taken not to touch the board with bare hands.

Who is correct?

- A. A only
- B. B only
- C. Both A and B
- D. Neither A nor B

9. Wiring harnesses are being discussed.

*Technician A* says a wire harness is an assembled group of wires that branches out to the various electrical components.

*Technician B* says most under-hood harnesses are simple harnesses.

Who is correct?

- A. A only
- B. B only
- C. Both A and B
- D. Neither A nor B

10. Wiring diagrams are being discussed.

*Technician A* says wiring diagrams give the exact location of the electrical components.

*Technician B* says a wiring diagram will indicate what circuits are interconnected, where circuits receive their voltage source, and what color of wires are used in the circuit.

Who is correct?

- A. A only
- B. B only
- C. Both A and B
- D. Neither A nor B



## AUTOMOTIVE BATTERIES

### UPON COMPLETION AND REVIEW OF THIS CHAPTER, YOU SHOULD BE ABLE TO UNDERSTAND AND DESCRIBE:

- The purposes of the battery.
- The construction of conventional, maintenance-free, hybrid, and recombination batteries.
- The main elements of the battery.
- The chemical action that occurs to produce current in a battery.
- The chemical reaction that occurs in the battery during cycling.
- The differences, advantages, and disadvantages between battery types
- The function of HEV batteries
- The operation and purpose of ultra-capacitors
- Describe the different types of battery terminals used.
- Describe the methods used to rate batteries.
- Determine the correct battery to be installed into a vehicle.
- Explain the effects of temperature on battery performance.
- Describe the different loads or demands placed upon a battery during different operating conditions.
- Explain the major reasons for battery failure.
- Define battery-related terms such as deep cycle, electrolyte solution, and gassing.

#### Shop Manual

Chapter 5, page 185

### INTRODUCTION

An automotive battery (Figure 5-1) is an **electrochemical** device capable of storing and producing electrical energy. Electrochemical refers to the chemical reaction of two dissimilar materials in a chemical solution that results in electrical current. When the battery is connected to an external load, such as a starter motor, an energy conversion occurs that results in an electrical current flowing through the circuit. Electrical energy is produced in the battery by the chemical reaction that occurs between two dissimilar plates that are immersed in an electrolyte solution. The automotive battery produces direct current (DC) electricity that flows in only one direction.

When discharging the battery (current flowing from the battery), the battery changes chemical energy into electrical energy. It is through this change that the battery releases stored energy. During charging (current flowing through the battery from the charging system), electrical energy is converted into chemical energy. As a result, the battery can store energy until it is needed.

**The automotive battery has several important functions, including:**

1. It operates the starting motor, ignition system, electronic fuel injection, and other electrical devices for the engine during cranking and starting.



© Delmar/Cengage Learning

**FIGURE 5-1** Typical automotive 12-volt battery.

2. It supplies all the electrical power for the vehicle accessories whenever the engine is not running or when the vehicle's charging system is not working.
3. It furnishes current for a limited time whenever electrical demands exceed charging system output.
4. It acts as a stabilizer of voltage for the entire automotive electrical system.
5. It stores energy for extended periods of time.

**AUTHOR'S NOTE:** The battery does not store energy in electrical form. The battery stores energy in chemical form.

The largest demand placed on the battery occurs when it must supply current to operate the starter motor. The amperage requirements of a starter motor may be over several hundred amperes. This requirement is also affected by temperatures, engine size, and engine condition.

After the engine is started, the vehicle's charging system works to recharge the battery and to provide the current to run the electrical systems. Most AC generators have a maximum output of 60 to 150 amperes. This is usually enough to operate all of the vehicle's electrical systems and meet the demands of these systems. However, under some conditions (such as the engine running at idle) generator output is below its maximum rating. If there are enough electrical accessories turned on during this time (heater, wipers, headlights, and radio) the demand may exceed the AC generator output. During this time, the battery must supply the additional current.

Even with the ignition switch turned off, there are electrical demands placed on the battery. Clocks, memory seats, engine computer memory, body computer memory, and electronic sound system memory are all examples of key-off loads. The total current draw of key-off loads is usually less than 50 milliamperes.

In the event that the vehicle's charging system fails, the battery must supply all of the current necessary to run the vehicle. The amount of time a battery can be discharged at a certain

Electrical loads that are still present when the ignition switch is in the OFF position are called key-off or parasitic loads.

current rate until the voltage drops below a specified value is referred to as **reserve capacity**. Most batteries will supply a reserve capacity of 25 amperes for approximately 120 minutes before discharging too low to keep the engine running.

The amount of electrical energy that a battery is capable of producing depends on the size, weight, active area of the plates, and the amount of sulfuric acid in the electrolyte solution.

In this chapter, you will study the design and operation of different types of batteries currently used in automobiles. These include conventional batteries, maintenance-free batteries, hybrid batteries, and recombination batteries.

The condition of the battery should be the first test performed on a vehicle with an electrical problem. Without proper battery performance, the entire electrical system is affected.

The lead peroxide is composed of small grains of particles. This gives the plate a high degree of porosity, allowing the electrolyte to penetrate the plate.

Lead peroxide is also called lead dioxide.

Usually, negative plate groups contain one more plate than positive plate groups to help equalize the chemical activity.

## CONVENTIONAL BATTERIES

The conventional battery is constructed of seven basic components:

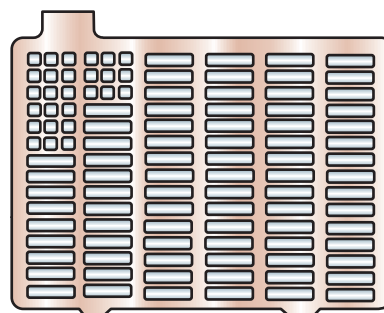
1. Positive plates.
2. Negative plates.
3. Separators.
4. Case.
5. Plate straps.
6. Electrolyte.
7. Terminals.

The difference between “3-year” and “5-year” batteries is the quantity of **material expanders** used in the construction of the plates and the number of plates used to build a cell. Material expanders are fillers that can be used in place of the active materials. They are used to keep the manufacturing costs low.

A plate, either positive or negative, starts with a **grid**. Grids are generally made of lead alloys, usually antimony. About 5% to 6% antimony is added to increase the strength of the grid. The grid is the frame structure with connector tabs at the top. The grid has horizontal and vertical grid bars that intersect at right angles (Figure 5-2). An active material made from ground lead oxide, acid, and material expanders is pressed into the grid in paste form. The positive plate is given a “forming charge” that converts the lead oxide paste into lead peroxide. The negative plate is given a “forming charge” that converts the paste into sponge lead.

The negative and positive plates are arranged alternately in each **cell element** (Figure 5-3). Each cell element can consist of 9 to 13 plates. The positive and negative plates are insulated from each other by separators made of microporous materials. The construction of the element is completed when all of the positive plates are connected to each other and all of the negative plates are connected to each other. The connection of the plates is by plate straps (Figure 5-4).

A typical 12-volt automotive battery is made up of six cells connected in series (Figure 5-5). This means the positive side of a cell element is connected to the negative side of the next cell element. This is repeated throughout all six cells. By connecting the cells in series, the current capacity of the cell and cell voltage remain the same. The six cells produce 2.1 volts



Conventional  
5% antimony

© Delmar/Cengage Learning

FIGURE 5-2 Conventional battery grid.

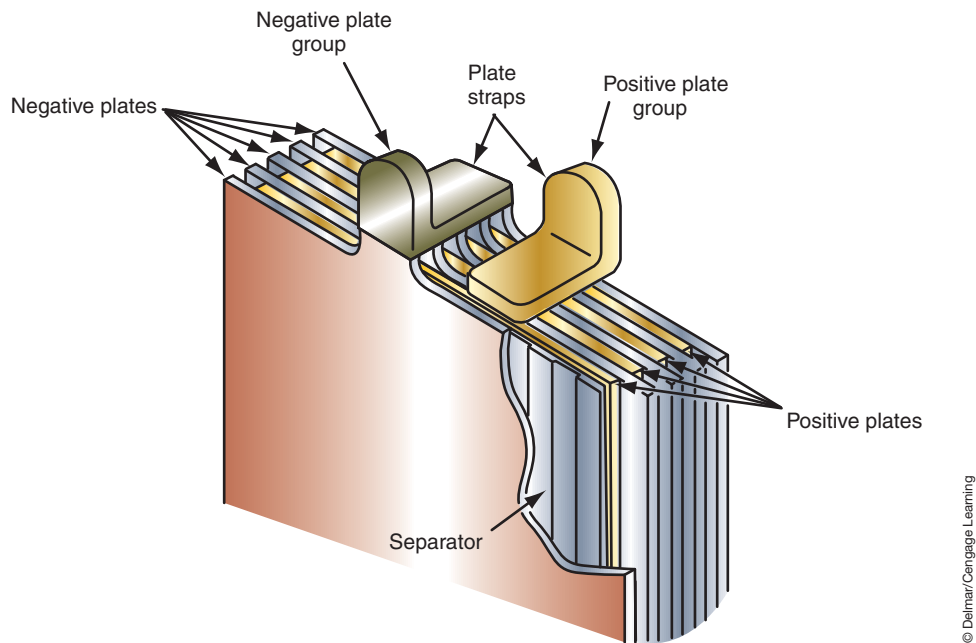


FIGURE 5-3 A battery cell consists of alternate positive and negative plates.

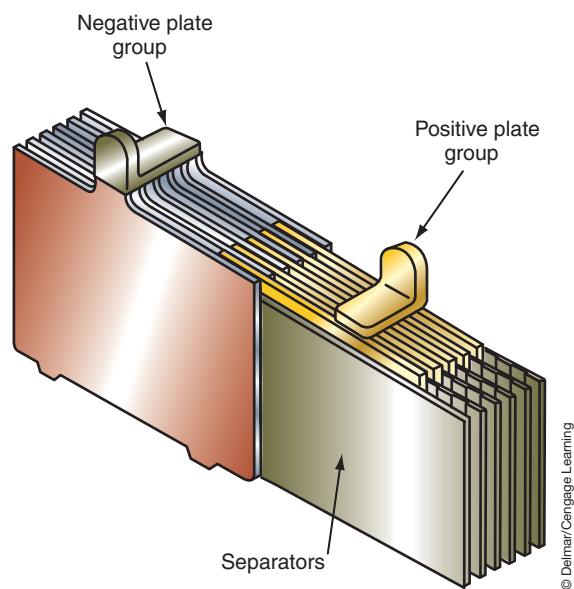


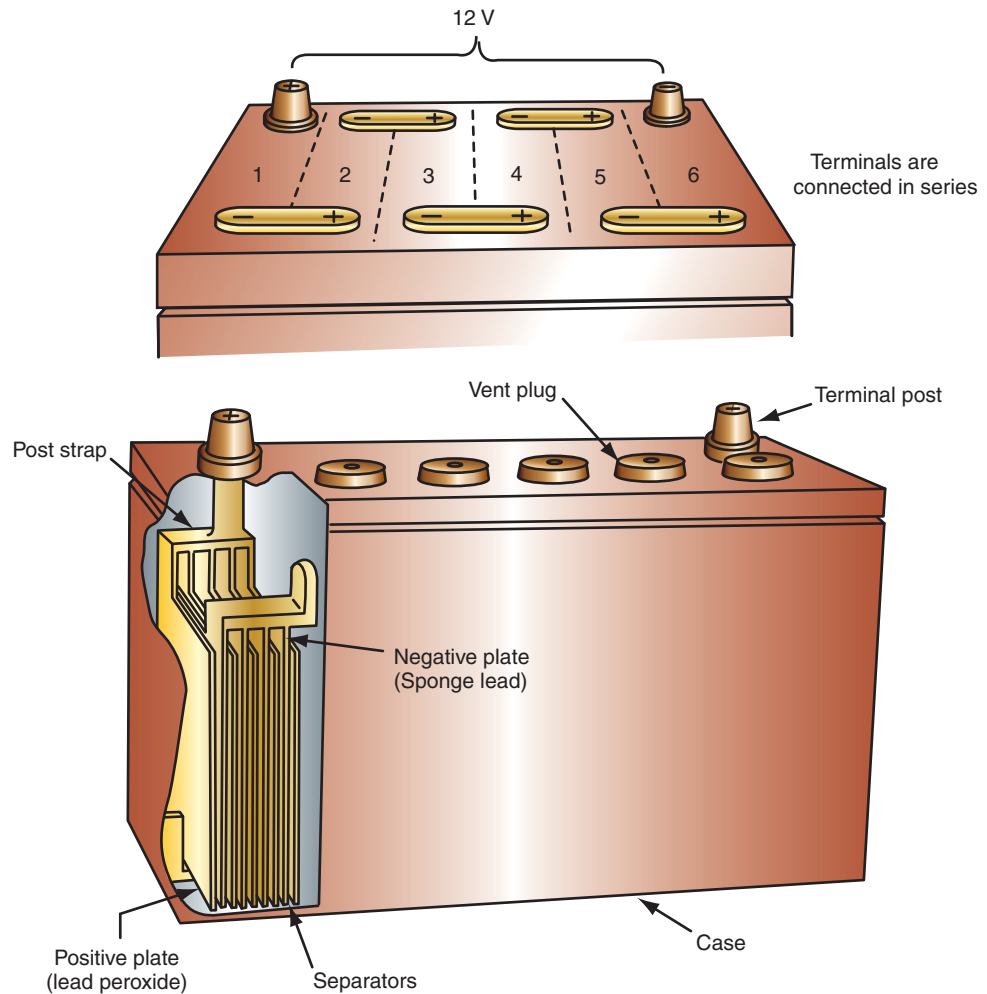
FIGURE 5-4 Construction of a battery element.

each. Wiring the cells in series produces the 12.6 volts required by the automotive electrical system. The plate straps provide a positive cell connection and a negative cell connection. The cell connection may be one of three types: through the partition, over the partition, or external (Figure 5-6). The cell elements are submerged in a cell case filled with **electrolyte** solution. Electrolyte consists of sulfuric acid diluted with water. The electrolyte solution used in automotive batteries consists of 64% water and 36% sulfuric acid, by weight. Electrolyte is both conductive and reactive.

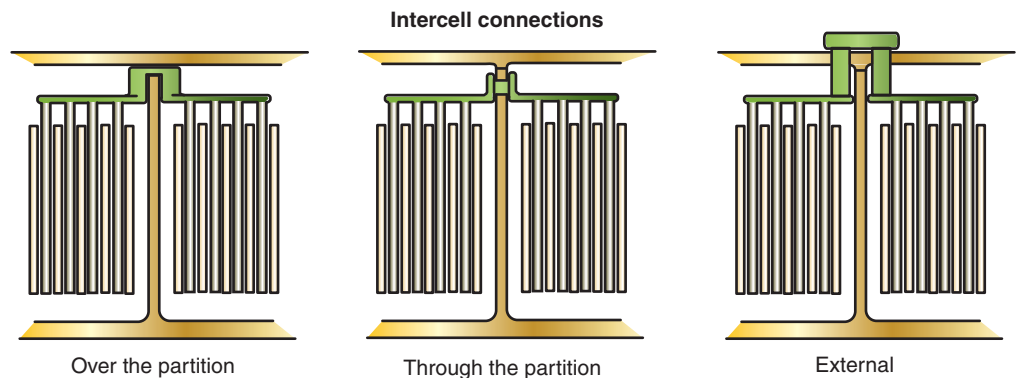
The battery case is made of polypropylene, hard rubber, and plastic base materials. The battery case must be capable of withstanding temperature extremes, vibration, and acid absorption. The cell elements sit on raised supports in the bottom of the case. By

Many batteries have envelope-type separators that retain active materials near the plates.

The most common connection used to connect cell elements is through the partition. It provides the shortest path and the least resistance.



**FIGURE 5-5** The 12-volt battery consists of six 2-volt cells that are wired in series.



**FIGURE 5-6** The cell elements can be connected using one of three intercell connection methods.

Lead acid batteries are also called flooded batteries.

raising the cells, chambers are formed at the bottom of the case that trap the sediment that flakes off the plates. If the sediment was not contained in these chambers, it could cause a conductive connection across the plates and short the cell. The case is fitted with a one-piece cover.

Because the conventional battery releases hydrogen gas when it is being charged, the case cover will have vents. The vents are located in the cell caps of a conventional battery (Figure 5-7).



© Delmar/Cengage Learning

**FIGURE 5-7** The vents of a conventional battery allow the release of gases.

## Chemical Action

Activation of the battery is through the addition of electrolyte. This solution causes the chemical actions to take place between the lead peroxide of the positive plates and the sponge lead of the negative plates. The electrolyte is also the carrier that moves electric current between the positive and negative plates through the separators.

The automotive battery has a fully charged **specific gravity** of 1.265 corrected to 80°F (27°C). Therefore, a specific gravity of 1.265 for electrolyte means it is 1.265 times heavier than an equal volume of water. As the battery discharges, the specific gravity of the electrolyte decreases because the electrolyte becomes more like water. The specific gravity of a battery can give you an indication of how charged a battery is.

Fully charged:	1.265 specific gravity
75% charged:	1.225 specific gravity
50% charged:	1.190 specific gravity
25% charged:	1.155 specific gravity
Discharged:	1.120 or lower specific gravity

These specific gravity values may vary slightly according to the design of the battery. However, regardless of the design, the specific gravity of the electrolyte in all batteries will decrease as the battery discharges. Temperature of the electrolyte will also affect its specific gravity. All specific gravity specifications are based on a standard temperature of 80°F (27°C). When the temperature is above that standard, the specific gravity is lower. When the temperature is below that standard, the specific gravity increases. Therefore, all specific gravity measurements must be corrected for temperature. A general rule to follow is to add 0.004 for every 10°F (5.5°C) above 80°F (27°C) and subtract 0.004 for every 10°F (5.5°C) below 80°F (27°C).

In operation, the battery is being partially discharged and then recharged. This represents an actual reversing of the chemical action that takes place within the battery. The constant cycling of the charge and discharge modes slowly wears away the active materials on the cell plates. This action eventually causes the battery plates to sulfate. The battery must be replaced once the sulfation of the plates has reached the point that there is insufficient active plate area.

In the charged state, the positive plate material is essentially pure lead peroxide,  $PbO_2$ . The active material of the negative plates is spongy lead,  $Pb$ . The electrolyte is a solution of sulfuric acid,  $H_2SO_4$ , and water. The voltage of the cell depends on the chemical difference between the active materials.

### Shop Manual

Chapter 5, page 189,  
193

### Specific gravity

is the weight of a given volume of a liquid divided by the weight of an equal volume of water. Water has a specific gravity of 1.000.





## A BIT OF HISTORY

Lead acid batteries date back to 1859. Alexander Graham Bell used a primitive battery to make his first local call in 1876. Once it was learned how to recharge the lead acid batteries, they were installed into the automobile. These old-style batteries could not hold a charge very well and it was believed that placing the battery on a concrete floor made them discharge faster. Although this fable has no truth to it, the idea has hung on for years.

The illustration (Figure 5-8) shows what happens to the plates and electrolyte during discharge. The lead (Pb) from the positive plate combines with sulfate ( $\text{SO}_4$ ) from the acid, forming lead sulfate ( $\text{PbSO}_4$ ). While this is occurring, oxygen ( $\text{O}_2$ ) in the active material of the positive plate joins with the hydrogen ( $\text{H}_2$ ) from the electrolyte forming water ( $\text{H}_2\text{O}$ ). This water dilutes the acid concentration.

A similar reaction is occurring in the negative plate. Lead (Pb) is combining with sulfate ( $\text{SO}_4$ ), forming lead sulfate ( $\text{PbSO}_4$ ). The result of discharging is changing the positive plate from lead dioxide into lead sulfate and changing the negative plate into lead sulfate. Discharging a cell makes the positive and negative plates the same. Once they are the same, the cell is discharged.

The charge cycle is exactly the opposite (Figure 5-9). The lead sulfate ( $\text{PbSO}_4$ ) in both plates is split into its original forms of lead (Pb) and sulfate ( $\text{SO}_4$ ). The water in the electrolyte splits into hydrogen and oxygen. The hydrogen ( $\text{H}_2$ ) combines with the sulfate to become sulfuric acid again ( $\text{H}_2\text{SO}_4$ ). The oxygen combines with the positive plate to form the lead peroxide. This now puts the plates and the electrolyte back in their original form and the cell is charged.

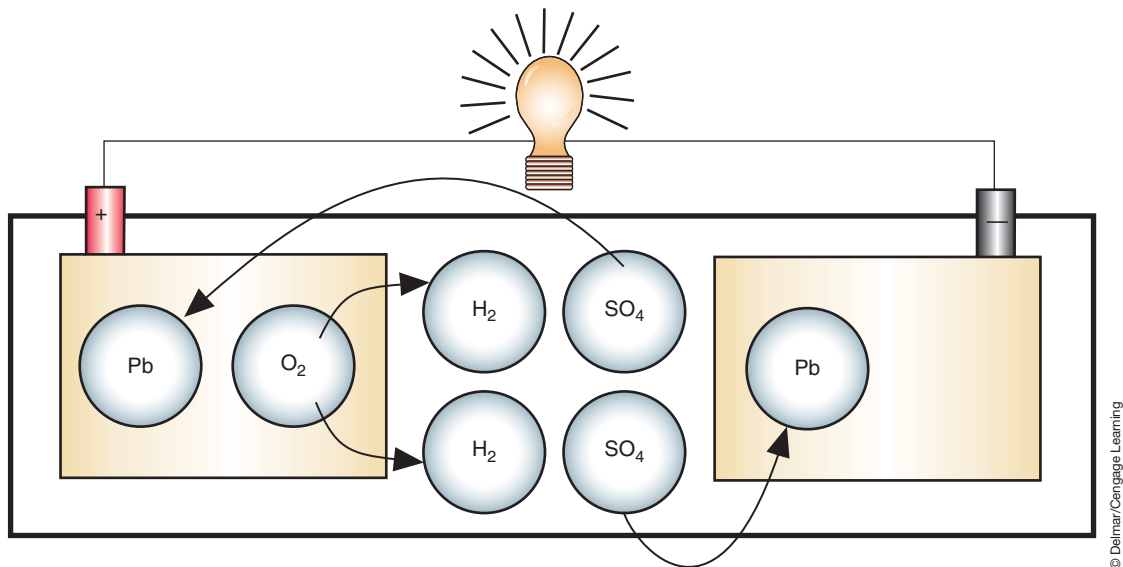


FIGURE 5-8 Chemical action that occurs inside of the battery during the discharge cycle.

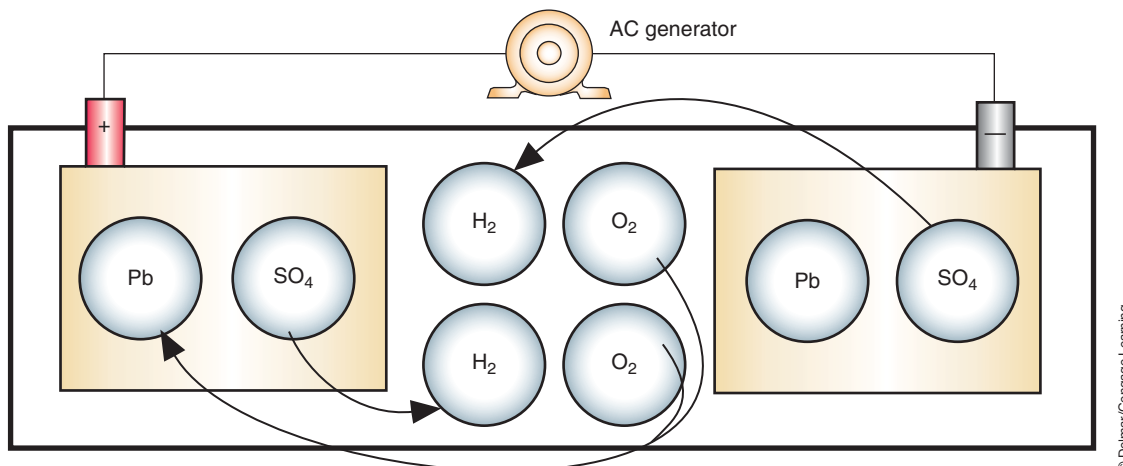


FIGURE 5-9 Chemical action inside of the battery during the charge cycle.

## MAINTENANCE-FREE BATTERIES

In a **maintenance-free battery** there is no provision for the addition of water to the cells. The battery is sealed. It (Figure 5-10) contains cell plates made of a slightly different compound than what is in a conventional battery. The plate grids contain calcium, cadmium, or strontium to reduce **gassing** and self-discharge. Gassing is the conversion of the battery water into hydrogen and oxygen gas. This process is also called electrolysis. The antimony used in conventional batteries is not used in maintenance-free batteries because it increases the breakdown of water into hydrogen and oxygen and because of its low resistance to overcharging. The use of calcium, cadmium, or strontium reduces the amount of vaporization that takes place during normal operation. The grid may be constructed with additional supports to increase its strength and to provide a shorter path, with less resistance, for the current to flow to the top tab (Figure 5-11).

Each plate is wrapped and sealed on three sides by an envelope design separator. The envelope is made from microporous plastic. By enclosing the plate in an envelope, the plate is insulated and reduces the shedding of the active material from the plate.

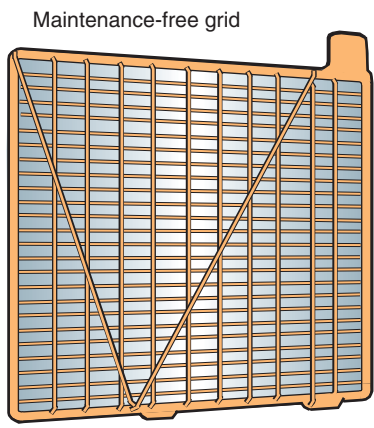
The battery is sealed except for a small vent so the electrolyte and vapors cannot escape (Figure 5-12). An expansion or condensation chamber allows the water to condense and drain back into the cells. Because the water cannot escape from the battery, it is not necessary to

**Maintenance-free batteries** are also called lead calcium batteries.



FIGURE 5-10 Maintenance-free batteries.

© Delmar/Cengage Learning



- Maintenance-free grid
- Calcium or strontium alloy...
- Adds strength.
  - Cuts gassing up to 97%.
  - Resists overcharge.

© Delmar/Cengage Learning

FIGURE 5-11 Maintenance-free battery grids with support bars give increased strength and faster electrical delivery.

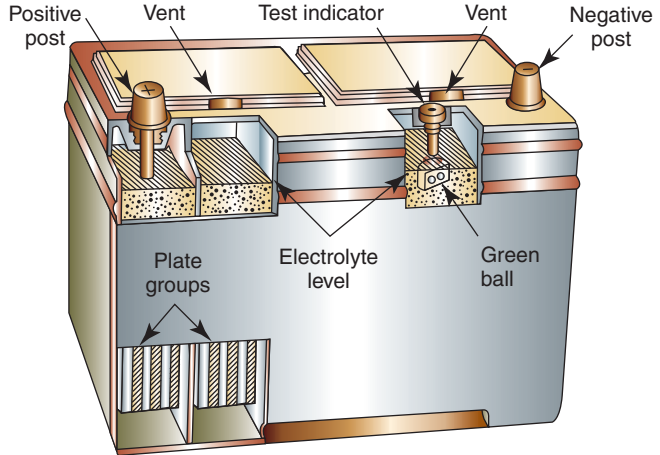


FIGURE 5-12 Construction of a maintenance-free battery.

© Delmar/Cengage Learning

add water to the battery on a periodic basis. Containing the vapors also reduces the possibility of corrosion and discharge through the surface because of electrolyte on the surface of the battery. Vapors leave the case only when the pressure inside the battery is greater than atmospheric pressure.

**AUTHOR'S NOTE:** If electrolyte and dirt are allowed to accumulate on the top of the battery case, it may create a conductive connection between the positive and negative terminals, resulting in a constant discharge on the battery.

## Shop Manual

Chapter 5, page 193

Some maintenance-free batteries have a built-in **hydrometer** to indicate the state of charge (Figure 5-13). A hydrometer is a test instrument that is used to check the specific gravity of the electrolyte to determine the battery's state of charge. If the dot that is at the bottom of the hydrometer is green, then the battery is fully charged (more than 65% charged). If the dot is black, the battery state of charge is low. If the battery does not have a built-in hydrometer, it cannot be tested with a hydrometer because the battery is sealed.

**AUTHOR'S NOTE:** It is important to remember that the built-in hydrometer is only an indication of the state of charge for one of the six cells of the battery and should not be used for testing purposes.

Many manufacturers have revised the maintenance-free battery to a "low maintenance-battery," in that the caps are removable for testing and electrolyte level checks. Also, the grid construction contains about 3.4% antimony. To decrease the distance and resistance of the path, that current flows in the grid, and to increase its strength, the horizontal and vertical grid bars do not intersect at right angles (Figure 5-14).

**Grid growth** is a condition where the grid grows little metallic fingers that extend through the separators and short out the plates.

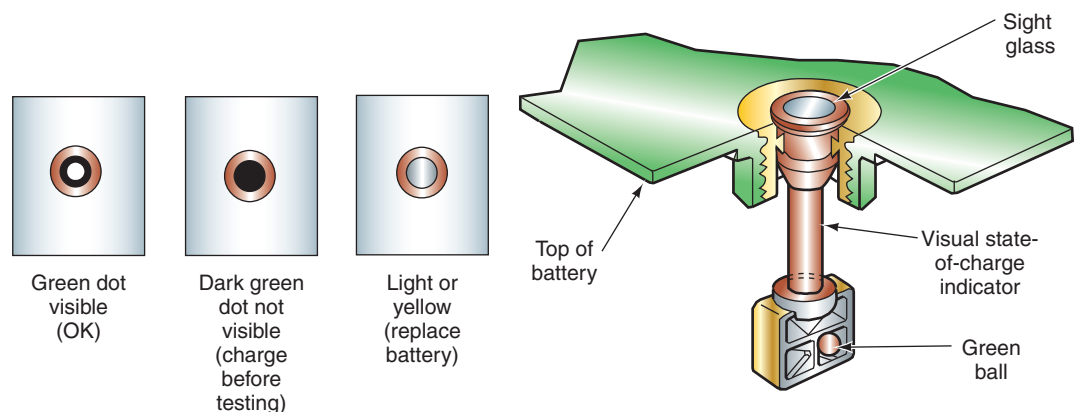
**Deep cycling** is to discharge the battery to a very low state of charge before recharging it.

**The advantages of maintenance-free batteries over conventional batteries include:**

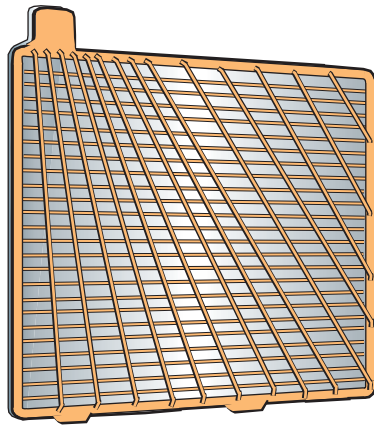
1. A larger reserve of electrolyte above the plates.
2. Increased resistance to overcharging.
3. Longer shelf life (approximately 18 months).
4. Ability to be shipped with electrolyte installed, reducing the possibility of accidents and injury to the technician.
5. Higher cold cranking amps rating.

**The major disadvantages of the maintenance-free battery include:**

1. **Grid growth** when the battery is exposed to high temperatures.
2. Inability to withstand **deep cycling**.



**FIGURE 5-13** One cell of a maintenance-free battery has a built-in hydrometer, which gives indication of overall battery condition.



Low maintenance  
3.4% or less antimony

© Delmar/Cengage Learning

**FIGURE 5-14** Low-maintenance battery grid with vertical grid bars intersecting at an angle.

3. Low reserve capacity.
4. Faster discharge by parasitic loads.
5. Shorter life expectancy.

## HYBRID BATTERIES

**AUTHOR'S NOTE:** The following discussion on hybrid batteries refers to a battery type and not to the batteries that are used in hybrid electric vehicles (HEVs).

The **hybrid battery** combines the advantages of the low-maintenance and maintenance-free battery. The hybrid battery can withstand six deep cycles and still retain 100% of its original reserve capacity. The grid construction of the hybrid battery consists of approximately 2.75% antimony alloy on the positive plates and a calcium alloy on the negative plates. This allows the battery to withstand deep cycling while retaining reserve capacity for improved cranking performance. Also, the use of antimony alloys reduces grid growth and corrosion. The lead calcium has less gassing than conventional batteries.

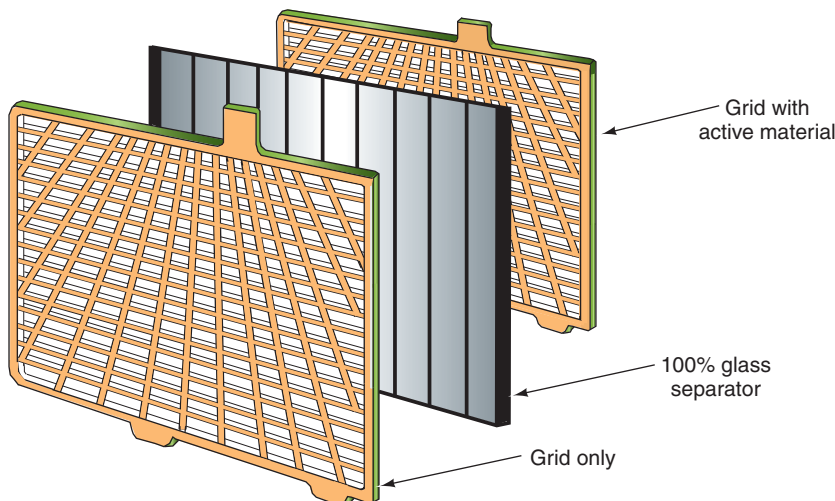
Grid construction differs from other batteries in that the plates have a lug located near the center of the grid. In addition, the vertical and horizontal grid bars are arranged in a **radial** pattern (Figure 5-15). By locating the lug near the center of the grid and using the **radial grid**



## A BIT OF HISTORY

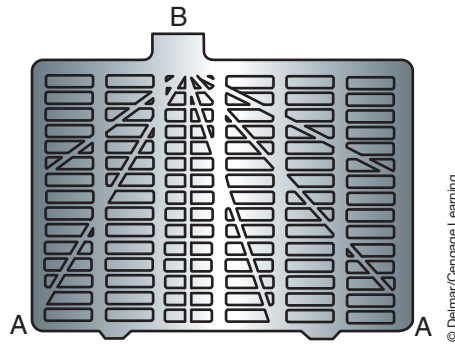
Buick first introduced the storage battery as standard equipment in 1906.

**Radial** means branching out from a common center.



© Delmar/Cengage Learning

**FIGURE 5-15** Hybrid grid and separator construction.



**FIGURE 5-16** The hybrid battery grid construction allows for faster current delivery. Electrical energy at point “A” has a shorter distance to travel to get to the tab at point “B.”

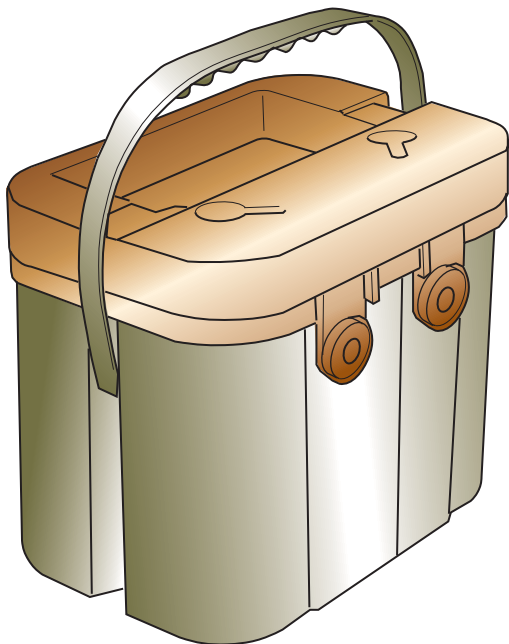
Some manufacturers are using fiberglass separators.

design, the current has less resistance and a shorter path to follow to the lug (Figure 5-16). This means the battery is capable of providing more current at a faster rate.

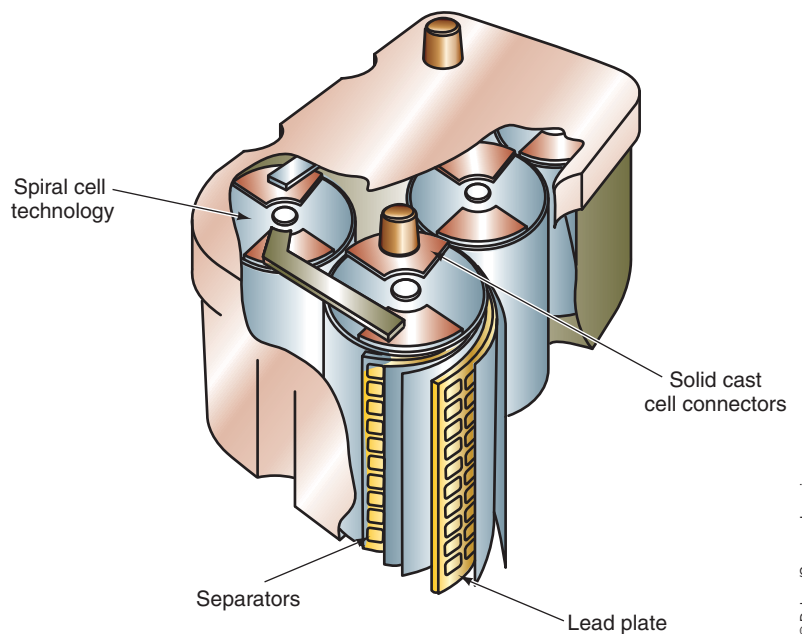
The separators used are constructed of glass with a resin coating. The glass separators offer low electrical resistance with high resistance to chemical contamination. This type of construction provides for increased cranking performance and battery life.

## RECOMBINATION BATTERIES

A recent variation of the automobile battery is the **recombination battery** (Figure 5-17). The recombination battery is sometimes called a gel-cell battery. It does not use a liquid electrolyte. Instead, it uses separators that hold a gel-type material. The separators are placed between the grids and have very low electrical resistance. The spiral design provides a larger plate surface area than that in conventional batteries (Figure 5-18). In addition, the close plate spacing results in decreased resistance. Because of this design, output voltage and current are higher than in conventional batteries. The extra amount of available voltage



**FIGURE 5-17** The recombination battery is one of the most recent advances in the automotive battery.



**FIGURE 5-18** Construction of the recombination battery cells.



(approximately 0.6 V) assists in cold-weather starting. Also, gassing is virtually eliminated and the battery can recharge faster.

**The following are some other safety features and advantages of the recombination battery:**

1. Contains no liquid electrolyte. If the case is cracked, no electrolyte will spill.
2. Can be installed in any position, including upside down.
3. Is corrosion free.
4. Has very low maintenance because there is no electrolyte loss.
5. Can last as much as four times longer than conventional batteries.
6. Can withstand deep cycling without damage.
7. Can be rated over 800 cold cranking amperes.

Recombination batteries recombine the oxygen gas that is normally produced on the positive plates with the hydrogen given off by the negative plates. This recombination of oxygen and hydrogen produces water (H<sub>2</sub>O) and replaces the moisture in the battery. The electrolyte solution of the recombination battery is absorbed into the separators.

The oxygen produced by the positive plates is trapped in the cell by special pressurized sealing vents. The oxygen gases then travel to the negative plates through small fissures in the gelled electrolyte. There are between one and six one-way safety valves in the top of the battery. The safety valves are necessary for maintaining a positive pressure inside of the battery case. This positive pressure prevents oxygen from the atmosphere from entering the battery and causing corrosion. Also, the safety valves must release excessive pressure that may be produced if the battery is overcharged.

### **Absorbed Glass Mat Batteries**

A variation of the recombination battery is the **absorbed glass mat (AGM) battery**. Instead of using a gel, they hold their electrolyte in a moistened fiberglass matting. The matting is sandwiched between the battery's lead plates. The plates are made of high-purity lead and are tightly compressed into six cells. Separation of the plates is done by acid-permeated vitreous separators that act as sponges to absorb acid. Each cell is enclosed in its own cylinder within the battery case. This results in a sealed battery.

During normal discharging and charging of the battery, the hydrogen and oxygen sealed within the battery are captured and recombined to form water within the electrolyte. This process of recombining hydrogen and oxygen eliminates the need to add water to the battery.

Typical of recombination batteries, the AGM battery is not easily damaged due to vibrations or impact. AGM batteries also have short recharging times and low internal resistance, which increases output.

### **Valve-Regulated Batteries**

All recombination batteries are classified as valve regulated batteries since they have one-way safety valves that control the internal pressure of the battery case. The valve will open to relieve any excessive pressure within the battery but at all other times the valve is closed and seals the battery. A **Valve-Regulated Lead–Acid (VRLA) battery** is another variation of the recombination battery. As the name implies, these are lead–acid batteries. Within the VRLA battery, the oxygen produced on the positive plate is absorbed by the negative plate. This causes a decrease in the amount of hydrogen produced at the negative plate. The small amount of hydrogen that is produced is combined with the oxygen to produce water that is returned to the electrolyte.

The VRLA uses a plate construction with a base of lead-tin-calcium alloy. The active material of one of the plates is porous lead dioxide, while the active material of the other plate is spongy lead. Sulfuric acid is used as the electrolyte. The sulfuric acid is absorbed into plate separators made of a glass-fiber fabric.



## HIGH-VOLTAGE BATTERIES

Automotive manufacturers have been investigating the use of high-voltage batteries for over 20 years. The first step was to the use of 42-volt systems. Today, high-voltage batteries are required by electric-drive vehicles. This section discussed the high-voltage battery system and its progression.

The system is called 12 volt/14 volt because the battery is 12 volts but the charging system delivers 14 volts. The 42-volt system is actually a 36-volt/42-volt system.



### A BIT OF HISTORY

In 1955, automobile manufacturers started to move from 6-volt electrical systems to the present 12-volt system. The change was due to the demand for increased power to accommodate a greater number of electrical accessories. In 1955, the typical car wiring harness weighed 8 to 10 pounds and required approximately 250 to 300 watts. In 1990, the typical car wiring harness weighed 15 to 20 pounds and required over 1,000 watts. In 2000, the typical car wiring increased to weigh between 22 and 28 pounds and required over 1,800 watts. The conventional 14-volt generator is capable of producing a maximum output of 2,000 watts.

### 42-Volt Systems

The first production vehicle that used the 42-volt system was the 2002 Toyota Crown Sedan, which was only sold in the Japanese market. Although the use of 42-volt systems is very limited at the current time, the technology learned has been applied to the electric hybrid systems.

As you have probably come to realize, the increased use of electrical and electronic accessories in today's vehicles has about tapped the capabilities of the 12-volt/14-volt electrical system. Electronic content in vehicles has been rising at a rate of about 6% per year. It's been estimated that by the end of the decade the electronic content will be about 40% of the total cost of a high-line vehicle. The electrical demands on the vehicle have risen from about 500 watts in 1970 to about 4,000 watts in 2005. It is estimated that in 10 years the demand may reach 10,000 watts.

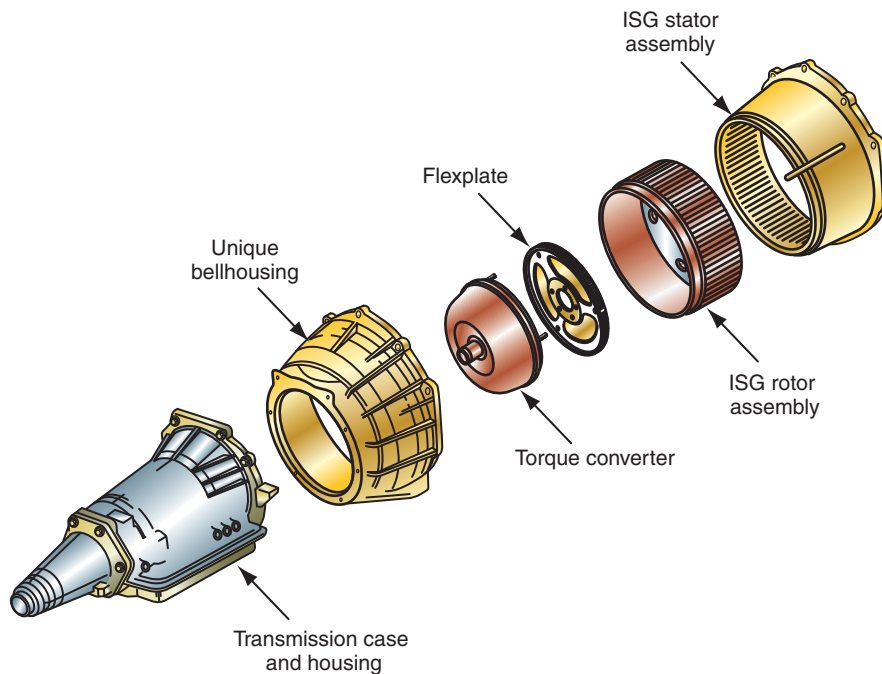
**AUTHOR'S NOTE:** The reason for using 42 volts is based on the current 12-volt system. Today's batteries are rated at 12 volts but actually store about 14 volts. In addition, the charging system produces about 14 to 15 volts when the engine is running. With the engine running, the primary source of electrical power is the charging system. This means that the automobile's electrical system is actually a 14-volt system. Forty-two volts represent three 12-volt batteries, but since they actually hold a 14-volt charge, the system is considered 42 volts (3 times 14 volts equals 42 volts).

An additional benefit that may be derived from the use of a 42-volt system is it allows manufacturers to electrify most of the inefficient mechanical and hydraulic systems that are currently used. The new technology will allow electromechanical intake and exhaust valve control, active suspension, electrical heating of the catalytic converters, electrically operated coolant and oil pumps, electric air conditioning compressor, brake-by-wire, steer-by-wire, and so on to be utilized. Studies have indicated that as these mechanical systems are replaced, fuel economy will increase by about 10% and emissions will decrease.

Additional fuel savings can also be realized due to the more efficient charging system used for the 42-volt system. Current 14-volt generators have an average efficiency across the engine speed range band of less than 60%. This translates to about 0.5 gallons (1.9L) of fuel for 65 miles (104.6 km) of driving to provide a continuous electrical load of 1,000 watts. With a 42-volt generator, the fuel consumption can be reduced the equivalent of up to 15% in fuel savings.

As simple as it may seem to convert from a 12-volt/14-volt system to a 36-volt/42-volt system, many challenges need to be overcome. It is not as simple as adding a higher-voltage output generator and expecting the existing electrical components to work. One of the biggest hurdles is the light bulb. Current 12-volt lighting filaments can't handle 42 volts. The dual voltage systems can be used as a step toward full 42-volt implantation. However, dual voltage systems are expensive to design. Another aspect of the 42-volt system is service technician training to address aspects of arcing, safety, and dual-voltage diagnostics.

Arcing is perhaps the greatest challenge facing the design and use of the 42-volt system. In fact, some manufacturers have abandoned further research and development of the system because of the problem with arcing. In the conventional 14-volt system, the power level is low enough that it is almost impossible to sustain an arc. Since there isn't enough electrical



**FIGURE 5-19** The ISG is usually located between the engine and the transmission in the bell housing.

© Delmar/Cengage Learning

energy involved, the arcs collapse quickly and there is less heat build up. Electrical energy in an arc at 42 volts is significantly greater and is sufficient to maintain a steady arc. The arc from a 42-volt system can reach a temperature of 6000°F (3,316°C).

One of the newest technologies to emerge from the research and development of the 42-volt system is the **integrated starter generator (ISG)**. Although this technology was not actually used on a 42-volt system, development was a result of this system. The ISG is one of the key contributors to the hybrid's fuel efficiency due to its ability to automatically stop and restart the engine under different operating conditions. A typical hybrid vehicle uses an electric induction motor or ISG between the engine and the transmission (Figure 5-19). The ISG performs many functions such as fast, quiet starting, automatic engine stops/starts to conserve fuel, recharges the vehicle batteries, smoothes driveline surges, and provide **regenerative braking**. These features will be discussed in greater detail in later chapters.

## HEV Batteries

As discussed earlier, lead–acid batteries are the most commonly used batteries in the automotive industry. By connecting the batteries in series to each other, they can provide high enough voltages to power some electric vehicles (EVs). For example, the first-generation General Motors' EV used twenty-six 12-volt lead–acid batteries connected in series to provide 312 volts. The down side of this arrangement is that the battery pack weighed 1,310 pounds (595 kg). In addition, distance that could be traveled between battery recharges was 55 to 95 miles (88 to 153 km). The next-generation EV used nickel-metal hydride (NiMH) batteries. These provided for a slightly longer traveling range between recharges. Although production of battery-powered EVs has slowed, the technology learned has provided for the development of hybrid vehicles. Now the hybrid technology is accelerating battery technology to the point that battery-powered EVs may become more common in the future.

The battery pack in a hybrid vehicle is typically made up of several cylindrical cells (Figure 5-20) or prismatic cells (Figure 5-21). These battery packs are often called high-voltage (HV) batteries. There are several types of HV batteries being used or in development.

**Regenerative braking** is a method of capturing the vehicle's kinetic energy while it slows down. The energy is used to recharge the batteries or a capacitor.

**Shop Manual**  
Chapter 5, page 207

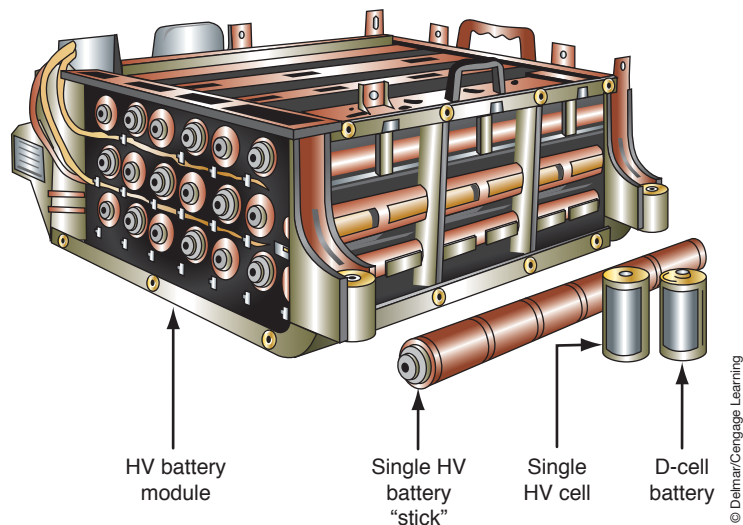


FIGURE 5-20 HV battery constructed of cylindrical cells.

© Delmar/Cengage Learning



FIGURE 5-21 Battery pack made of several prismatic cells.

© Delmar/Cengage Learning

NiCad batteries are also referred to as NiCd.

**Energy density** refers to the amount of energy that is available for a given amount of space.

**Nickel-Cadmium (NiCad) Batteries.** NiCad cells may have a future role in hybrid vehicles because of several advantages that it has. These include being able to withstand many deep cycles, low cost of production, and long service life. NiCad batteries perform very well when high energy boosts are required.

The negatives associated with the use of NiCad batteries include the following points: they use toxic metals, have low **energy density**, need to be recharged if they have not been used for a while, and suffer from the **memory effect**. The memory effect refers to the battery not being able to be fully recharged because it “remembers” its previous charge level. This results in a low battery charge due to a battery that is not completely discharged before it is recharged. For example, if the battery is consistently being recharged after it is only discharged 50%, the battery will eventually only accept and hold a 50% charge and not accept any higher charge.

The cathode (positive) electrode in a NiCad cell is made of fiber mesh covered with nickel hydroxide. The anode (negative) electrode is a fiber mesh that is covered with cadmium. The electrolyte is aqueous potassium hydroxide (KOH). The KOH is a conductor of ions and has little involvement in the chemical reaction process. During discharge, ions travel from the anode, through the KOH, and on to the cathode. During charging, the opposite occurs. Each cell produces 1.2 volts.

**Nickel-Metal Hydride (NiMH) Batteries.** NiMH batteries are very quickly replacing nickel-cadmium batteries since they are more environmentally friendly. They also have more capacity than the NiCad battery since they have a higher energy density. However, they have a lower current capacity when placed under a heavy load. At this time, the NiMH is the most common HV battery used in the hybrid vehicle.

The issue facing HEV manufacturers is that the NiMH battery has a relatively short service life. Service life suffers as a result of the battery being subjected to several deep cycles of charging and discharging over its lifetime. In addition, NiMH cells generate heat while being charged and they require long charge times. Because of the service life issue, most batteries used in HEVs have an eight-year warranty.

The cathode electrode of the NiMH battery is a fiber mesh that contains nickel hydroxide. The anode electrode is made of hydrogen-absorbing metal alloys. The most commonly used alloys are compounds containing two to three of the following metals: titanium, vanadium, zirconium, nickel, cobalt, manganese, and aluminum. The amount of hydrogen that can be accumulated and stored by the alloy is far greater than the actual volume of the alloy.

The cathode and anode electrodes are separated by a sheet of fine fibers saturated with an aqueous and alkaline electrolyte-KOH. The components of the cell are typically placed in a metal housing and then the unit is sealed. There is a safety vent that allows high pressures to escape, if needed.

Under load the cell discharges and the hydrogen moves from the anode to the cathode electrode. Since the electrolyte only supports the ion movement from one electrode to the other, it has no active role in the chemical reaction. This means that the electrolyte level does not change because of the chemical reaction. When the cell is recharged, hydrogen moves from the cathode to the anode electrode.

The cells can be constructed either cylindrical or prismatic. Both designs are currently being used in today's hybrid vehicles. The prismatic design requires less storage space but had less energy density than the cylindrical design.

A 300-volt battery is constructed of 240 cells that produce 1.2 volts each. The cells are made into a module, with each module having 6 cells. Each module is actually a self-contained 7.2 volt battery. The modules are connected in series to create the total voltage (Figure 5-22).

A service disconnect is used to disable the HV system if repairs or service to any part of the system is required (Figure 5-23). This service connector provides two functions that are used to separate the HV battery pack into two separate batteries, with approximately 150 volts each. First, when the service disconnect is lifted up, it opens a high-voltage interlock loop (HVIL), then when the service disconnect is fully removed, it opens the high-voltage



© Delmar/Cengage Learning

**FIGURE 5-22** Cell module connections.





**FIGURE 5-23** Service disconnect plug.

connector. When the HVIL is open, **contactors** should open. Contactors are heavy-duty relays that are connected to the positive and negative sides of the HV battery. The contactors are normally open and require a 12-volt supply to keep them closed. When the service disconnect is lifted and the HVIL is opened, the voltage supply to the contactors is interrupted and the contactors should open. However, if arcing has occurred that may have welded the contacts of the contactors together, the circuit will not be opened. This will result in a DTC being set.

**Lithium-Ion (Li-ion) Batteries.** Rechargeable lithium-based batteries are very similar in construction to the nickel-based batteries just discussed. Positives associated with the use of lithium batteries include high energy density, limited memory effect, and they being environmentally friendly. The negatives are lithium is considered an alkali metal and oxidizes very rapidly in air and water, which makes lithium highly flammable and slightly explosive when exposed to air and water. Lithium metal is also corrosive.

**AUTHOR'S NOTE:** Lithium is the lightest metal and provides the highest energy density of all known metals.

The anode electrode of a Li-ion battery is made of graphite (a form of carbon). The cathode mostly comprises graphite and a lithium alloy oxide. Due to the safety issues associated with lithium metal, the Li-ion battery uses a variety of lithium compounds. A manganese li-ion battery has been developed for use in hybrid vehicles that has the potential of lasting twice as long as a NiMH battery.

The electrolyte is a lithium salt mixed in a liquid. Polyethylene membranes are used to separate the plates inside the cells and, in effect, separate the ions from the electrons. The membranes have extremely small pores that allow the ions to move within the cell.

As with most other rechargeable cells, ions move from the anode to the cathode when the cell is providing electrical energy and during recharging, the ions are moved back from the cathode to the anode.

**Lithium-Polymer (Li-Poly) Batteries.** The lithium-polymer battery is nearly identical to a li-ion battery and share the same electrode construction. The difference is in the lithium salt electrolyte. The Li-Poly cell holds the electrolyte in a thin solid, polymer composite (polyacrylonitrile) instead as a liquid. The solid polymer electrolyte is not flammable.

The dry polymer electrolyte does not conduct electricity. Instead, it allows ions to move between the anode and cathode. The polymer electrolyte also serves as the separator between the plates. Since the dry electrode has very high resistance, it is unable to provide bursts of current for heavy loads. The efficiency can be increased by increasing the cell temperature above 140°F (60°C). The voltage of a Li-Poly cell is about 4.23 volts when fully charged.

## ULTRA-CAPACITORS

**Ultra-capacitors** are capacitors constructed to have a large electrode surface area and a very small distance between the electrodes. Unlike conventional capacitors that use a dielectric, the ultra-capacitors use an electrolyte (Figure 5-24). It also stores electrical energy at the boundary between the electrodes and the electrolyte. Although an ultra-capacitor is an electrochemical device, no chemical reactions are involved in the storing of electrical energy. This means that the ultra-capacitor remains an electrostatic device. The design of the ultra-capacitor increases its capacitance capabilities to as much as 5000 farads.

Ultra-capacitors are used in many present-day hybrid vehicles and in some experimental fuel cell EVs because of their ability to quickly discharge high voltages and then be quickly recharged. This makes them ideal for increasing boost to electrical motors during times of acceleration or heavy loads. Ultra-capacitors are also very good at absorbing the energy from regenerative braking.

## BATTERY TERMINALS

**Terminals** provide a means of connecting the battery plates to the vehicle's electrical system. All automotive batteries have two terminals. One terminal is a positive connection; the other is a negative connection. The battery terminals extend through the cover or the side of the battery case. The following are the most common types of battery terminals (Figure 5-25):

- 1. Post or top terminals:** Used on most automotive batteries. The positive post will be larger than the negative post to prevent connecting the battery in reverse polarity.



### A BIT OF HISTORY

The Toyota Prius Hybrid was the first automobile to use a bank of ultra-capacitors. The ultra-capacitors store energy captured during deceleration and braking and release that energy to assist the engine during acceleration. The energy in the capacitors is also used to restart the engine during the stop/start sequence.

**Shop Manual**  
Chapter 5, page 192

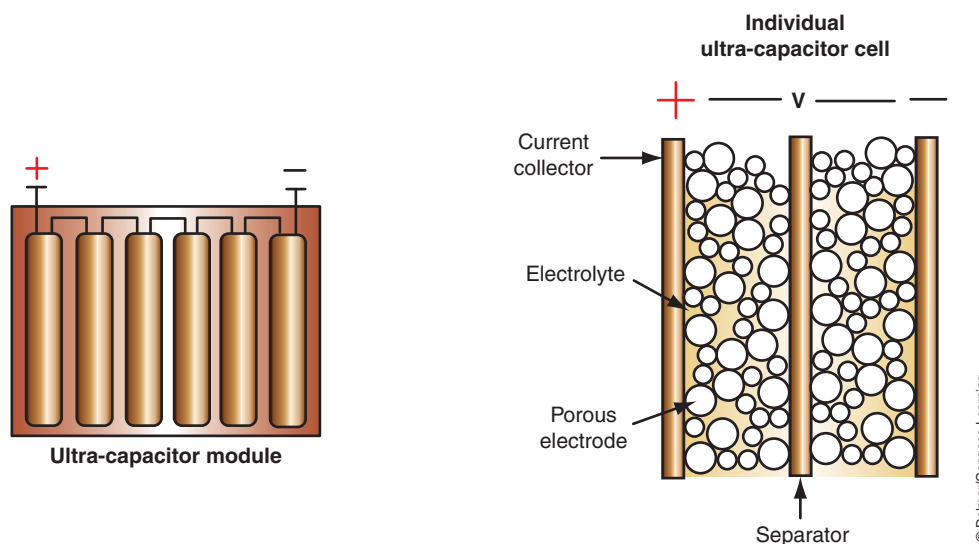
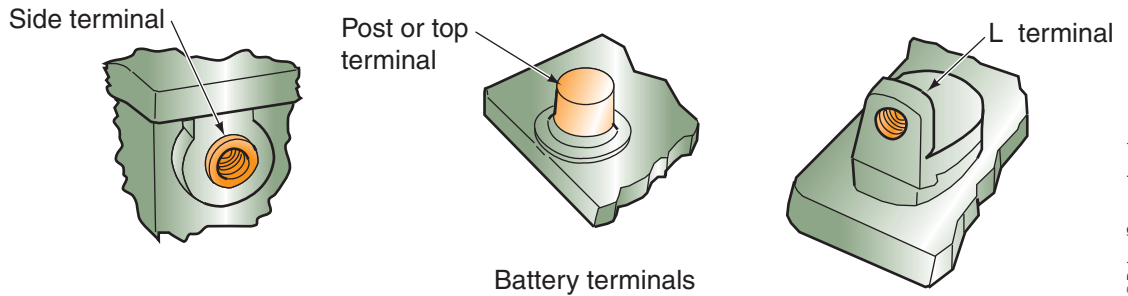


FIGURE 5-24 Ultra-capacitor cell construction.





**FIGURE 5-25** The most common types of automotive battery terminals.

© Delmar/Cengage Learning

2. **Side terminals:** Positioned in the side of the container near the top. These terminals are threaded and require a special bolt to connect the cables. Polarity identification is by positive and negative symbols.
3. **L terminals:** Used on specialty batteries and some imports.

## BATTERY RATINGS

Battery capacity ratings are established by the Battery Council International (BCI) in conjunction with the Society of Automotive Engineers (SAE). Battery cell voltage depends on the types of materials used in the construction of the battery. Current capacity depends on several factors:

1. The size of the cell plates. The larger the surface area of the plates, the more chemical action that can occur. This means a greater current is produced.
2. The weight of the positive and negative plate active materials.
3. The weight of the sulfuric acid in the electrolyte solution.

The battery's current capacity rating is an indication of its ability to deliver cranking power to the starter motor and of its ability to provide reserve power to the electrical system. The commonly used current capacity ratings are explained in the following sections.

### Ampere-Hour Rating

The **ampere-hour rating** is the amount of steady current that a fully charged battery can supply for 20 hours at 80°F (26.7°C) without the terminal voltage falling below 10.5 volts. For example, if a battery can be discharged for 20 hours at a rate of 4.0 amperes before its terminal voltage reads 10.5 volts, it would be rated at 80 ampere-hours. This method of battery rating is not widely used.

### Cold Cranking Rating

**Cold cranking rating** is the most common method of rating automotive batteries. It is determined by the load, in amperes, that a battery is able to deliver for 30 seconds at 0°F (−17.7°C) without terminal voltage falling below 7.2 volts (1.2 volts per cell) for a 12-volt battery. The cold cranking rating is given in total amperage and is identified as 300 CCA, 400 CCA, 500 CCA, and so on. Some batteries are rated as high as 1,100 CCA.

### Cranking Amps

**Cranking Amps (CA)** is an indication of the battery's ability to provide a cranking amperage at 32°F (0°C). This rating uses the same test procedure as the cold cranking rating or CCA discussed earlier, except it uses a higher temperature. To convert CA to CCA, divide the CA by 1.25. For example, a 650-CCA-rated battery is the same as 812 CA. It is important that the technician does not misread the rating and think the battery is rated as CCA instead of CA.

**Cold cranking rating** is also called cold cranking amps (CCA).

## Reserve-Capacity Rating

The **reserve-capacity rating** is determined by the length of time, in minutes, that a fully charged battery can be discharged at 25 amperes before battery voltage drops below 10.5 volts. This rating gives an indication of how long the vehicle can be driven, with the headlights on, if the charging system should fail.

## Battery Size Selection

Some of the aspects that determine the battery rating required for a vehicle include engine size, engine type, climatic conditions, vehicle options, and so on. The requirement for electrical energy to crank the engine increases as the temperature decreases. Battery power drops drastically as temperatures drop below freezing (Figure 5-26). The engine also becomes harder to crank due to the tendency of oils to thicken when cold, which results in increased friction. As a general rule, it takes 1 ampere of cold cranking power per cubic inch of engine displacement. Therefore, a 200-cubic-inch displacement (CID) engine should be fitted with a battery of at least 200 CCA. To convert this into metric, it takes 1 amp of cold cranking power for every 16 cm<sup>3</sup> of engine displacement. A 1.6-liter engine should require at least a battery rated at 100 CCA. This rule may not apply to vehicles that have several electrical accessories. The best method of determining the correct battery is to refer to the manufacturer's specifications.

The battery that is selected should fit the battery holding fixture and the holddown must be able to be installed. It is also important that the height of the battery not allow the terminals to short across the vehicle hood when it is shut. BCI group numbers are used to indicate the physical size and other features of the battery. This group number does not indicate the current capacity of the battery.

## BATTERY CABLES

**Battery cables** are high-current conductors that connect the battery to the vehicle's electrical system. Battery cables must be of a sufficient capacity to carry the current required to meet all electrical demands (Figure 5-27). Normal 12-volt cable size is usually 4 or 6 gauge. Various forms of clamps and terminals are used to assure a good electrical connection at each end of the cable. Connections must be clean and tight to prevent arcing, corrosion, and high-voltage resistance.

Temperature	% of Cranking Power
80°F (26.7°C)	100
32°F (0°C)	65
0°F (-17.8°C)	40

**FIGURE 5-26** The effect temperature has on the cranking power of the battery.



**FIGURE 5-27** The battery cable is designed to carry the high current required to start the engine and supply the vehicle's electrical systems.



## A BIT OF HISTORY

The storage battery on early automobiles was mounted under the car. It wasn't until 1937 that the battery was located under the hood for better accessibility. Today, with the increased use of maintenance-free batteries, some manufacturers have "buried" the battery again. For example, to access the battery on some vehicles, you must remove the left front wheel and work through the wheel well. Also, some batteries are now located in the trunk area.

The positive cable is usually red (but not always), and the negative cable is usually black. The positive cable will fasten to the starter solenoid or relay. The negative cable fastens to ground on the engine block or chassis. Some manufacturers use a negative cable with no insulation. Sometimes the negative battery cable may have a body grounding wire to help assure that the vehicle body is properly grounded.

**AUTHOR'S NOTE:** It is important to properly identify the positive and negative cables when servicing, charging, or jumping the battery. Do not rely on the color of the cable for this identification; use the markings on the battery case.

**AUTHOR'S NOTE:** Pinch on battery cable clamps are a temporary repair only!

## BATTERY HOLDDOWNS

All batteries must be secured in the vehicle to prevent damage and the possibility of shorting across the terminals if the battery tips. Normal vibrations cause the plates to shed their active materials. **Holddowns** reduce the amount of vibration and help increase the life of the battery (Figure 5-28).

In addition to holddowns, many vehicles may have a heat shield surrounding the battery (Figure 5-29). This heat shield is usually made of plastic and prevents under-hood temperatures from damaging the battery.

**AUTHOR'S NOTE:** It is important that all hold-downs and heat shields be installed to prevent early battery failure.

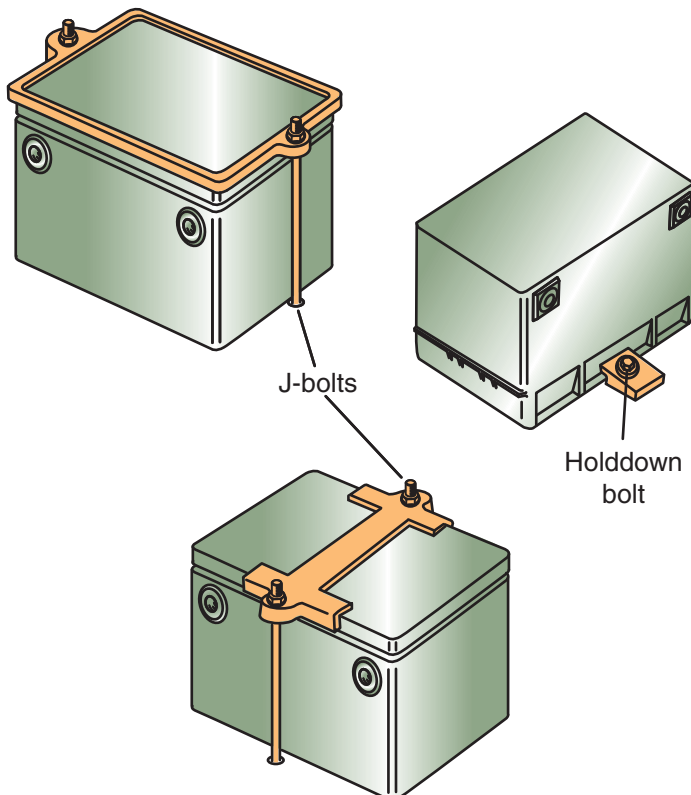


FIGURE 5-28 Different types of battery hold-downs.

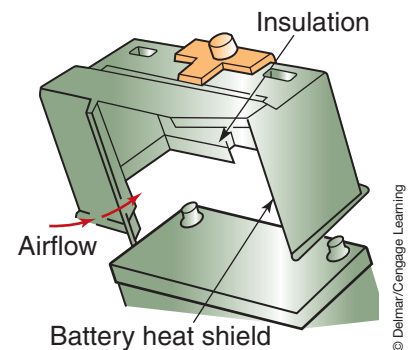


FIGURE 5-29 Some vehicles are equipped with a heat shield to protect the battery from excessive heat.

© Delmar/Cengage Learning

© Delmar/Cengage Learning

## SUMMARY

---

- An automotive battery is an electrochemical device that provides for and stores electrical energy.
- Electrical energy is produced in the battery by the chemical reaction that occurs between two dissimilar plates that are immersed in an electrolyte solution.
- An automotive battery has the following important functions:
  1. It operates the starting motor, ignition system, electronic fuel injection, and other electrical devices for the engine during cranking and starting.
  2. It supplies all the electrical power for the vehicle accessories whenever the engine is not running or at low idle.
  3. It furnishes current for a limited time whenever electrical demands exceed charging system output.
  4. It acts as a stabilizer of voltage for the entire automotive electrical system.
  5. It stores energy for extended periods of time.
- Electrical loads that are still placed on the battery when the ignition switch is in the OFF position are called key-off or parasitic loads.
- The amount of electrical energy that a battery is capable of producing depends on the size, weight, and active area of the plates and the specific gravity of the electrolyte solution.
- The conventional battery is constructed of seven basic components:
  1. Positive plates.
  2. Negative plates.
  3. Separators.
  4. Case.
  5. Plate straps.
  6. Electrolyte.
  7. Terminals.
- Electrolyte solution used in automotive batteries consists of 64% water and 36% sulfuric acid by weight.
- The electrolyte solution causes the chemical actions to take place between the lead dioxide of the positive plates and the sponge lead of the negative plates. The electrolyte is also the carrier that moves electric current between the positive and negative plates through the separators.
- The automotive battery has a fully charged specific gravity of 1.265 corrected to 80°F.
- Grid growth is a condition where the grid grows little metallic fingers that extend through the separators and short out the plates.
- Deep cycling is discharging the battery almost completely before recharging it.
- In a conventional battery, the positive plate is covered with lead peroxide and the negative plate is covered with sponge lead.
- In maintenance-free batteries, the cell plates contain calcium, cadmium, or strontium to reduce gassing and self-discharge.
- The grid construction of the hybrid battery consists of approximately 2.75% antimony alloy on the positive plates and a calcium alloy on the negative plates.
- The recombination battery uses separators that hold a gel-type material in place of liquid electrolyte.
- Absorbed glass mat (AGM) batteries hold their electrolyte in a moistened fiberglass matting that is sandwiched between the battery's high-purity lead plates. Separation of the plates is done by acid-permeated vitreous separators that act as sponges to absorb acid.
- Within a valve-regulated lead-acid (VRLA), the oxygen produced on the positive plates is absorbed by the negative plate, causing a decrease in the amount of hydrogen produced at the negative plate and combining it with the oxygen to produce water that is returned to the electrolyte.

## SUMMARY

### TERMS TO KNOW

Absorbed glass mat (AGM) battery  
Ampere-hour rating  
Battery cables  
Cell element  
Cold cranking rating  
Contactors  
Cranking amps (CA)  
Deep cycling  
Electrochemical  
Electrolyte  
Energy density  
Gassing  
Grid  
Grid growth  
Holddowns  
Hybrid batteries  
Hydrometer  
Integrated starter generator (ISG)  
Maintenance-free battery  
Material expanders  
Memory effect  
Radial  
Radial grid  
Recombination batteries  
Regenerative braking  
Reserve capacity  
Reserve-capacity rating  
Specific gravity  
Terminals  
Ultra-capacitors  
Valve Regulated Lead-Acid (VRLA) batteries

- Methods that are being used and developed for the electrical architecture of the 42-volt system include a single 42-volt system or a dual-voltage system.
- The dual voltage system may use a dual generator system where one generator operates at 42 volts, while the other operates at 14 volts.
- A dual stator, dual voltage system produces dual voltage from a single alternator that has two output voltages.
- A DC/DC converter is configured to provide a 14 V output from the 42-volt input. The 14 V output can be used to supply electrical energy to those components that do not require 42 volts.
- Cell construction of the NiCad battery is the cathode (positive) electrode is made of fiber mesh covered with nickel hydroxide, while the anode (negative) electrode is a fiber mesh that is covered with cadmium. The electrolyte is aqueous potassium hydroxide (KOH).
- During discharge, ions travel from the anode, through the KOH, and on to the cathode. During charging, the opposite occurs.
- The cathode electrode of the NiMH battery is a fiber mesh that contains nickel hydroxide. The anode electrode is made of hydrogen-absorbing metal alloys. The cathode and anode electrodes are separated by a sheet of fine fibers saturated with an aqueous and alkaline electrolyte-KOH.
- Under load, the cell discharges and the hydrogen moves from the anode to the cathode electrode. Since the electrolyte only supports the ion movement from one electrode to the other, it has no active role in the chemical reaction, and the electrolyte level does not change.
- A 300-volt NiMH battery is constructor of 240 cells that produce 1.2 volts each. The cells are made into a module, with each module having 6 cells. The modules are connected in series to create the total voltage.
- A service disconnect in the HV battery is used to disable the HV system if repairs or service to any part of the system is required. This service connector provides two functions that are used to separate the HV battery pack into two separate batteries, with approximately 150 volts each.
- Contactors are heavy-duty relays that are connected to the positive and negative sides of the HV battery.
- The contactors are normally open and require a 12-volt supply to keep them closed.
- Ultra-capacitors are capacitors constructed to have a large electrode surface area and a very small distance between the electrodes.
- Ultra-capacitors are used in many present day hybrid vehicles and in some experimental fuel cell electric vehicles because of their ability to quickly discharge high voltages and then be quickly recharged.
- Hybrids that use regenerative braking, a starter/generator with the stop/start feature, and the 42-volt system will use ultra-capacitors to restart the engine.
- The three most common types of battery terminals are:
  1. Post or top terminals: Used on most automotive batteries. The positive post will be larger than the negative post to prevent connecting the battery in reverse polarity.
  2. Side terminals: Positioned in the side of the container near the top. These terminals are threaded and require a special bolt to connect the cables. Polarity identification is by positive and negative symbols.
  3. L terminals: Used on specialty batteries and some imports.
- The most common methods of battery rating are cold cranking, cranking amps, reserve capacity, and ampere-hour.



## REVIEW QUESTIONS

### Short-Answer Essays

1. Explain the purposes of the battery.
  2. Describe how a technician can determine the correct battery to be installed into a vehicle.
  3. Describe the methods used to rate batteries.
  4. Describe the need for a 42-volt system.
  5. Explain the effects that temperature has on battery performance.
  6. Describe the different loads or demands that are placed on a battery during different operating conditions.
  7. List and describe the seven main elements of the conventional battery.
  8. What is the purpose of the service disconnect on a HV battery?
  9. List at least three safety concerns associated with working on or near the battery.
  10. Describe the difference in construction of the hybrid battery as compared to the conventional battery.
3. The assembly of the positive plates, negative plates, and separators is called the \_\_\_\_\_.
  4. The electrolyte solution used in automotive batteries consists of \_\_\_\_\_ % water and \_\_\_\_\_ % sulfuric acid.
  5. A fully charged automotive battery has a specific gravity of \_\_\_\_\_ corrected to 80°F (26.7°C).
  6. \_\_\_\_\_ is a condition where the grid grows little metallic fingers that extend through the separators and short out the plates.
  7. The \_\_\_\_\_ rating indicates the battery's ability to deliver a specified amount of current to start an engine at low ambient temperatures.
  8. The electrolyte solution causes the chemical actions to take place between the lead peroxide of the \_\_\_\_\_ plates and the \_\_\_\_\_ of the \_\_\_\_\_ plates.
  9. Some of the aspects that determine the battery rating required for a vehicle include engine \_\_\_\_\_, engine \_\_\_\_\_, \_\_\_\_\_ conditions, and vehicle \_\_\_\_\_.
  10. Electrical loads that are still present when the ignition switch is in the OFF position are called \_\_\_\_\_ loads.

### Fill in the Blanks

1. An automotive battery is an \_\_\_\_\_ device that provides for and stores \_\_\_\_\_ energy.
2. When discharging the battery, it changes \_\_\_\_\_ energy into \_\_\_\_\_ energy.

## MULTIPLE CHOICE

1. *Technician A* says the battery provides electricity by releasing free electrons.  
*Technician B* says the battery stores energy in chemical form.  
Who is correct?  
A. A only            C. Both A and B  
B. B only            D. Neither A nor B
2. *Technician A* says the largest demand on the battery is when it must supply current to operate the starter motor.  
*Technician B* says the current requirements of a starter motor may be over 100 amperes.  
Who is correct?  
A. A only            C. Both A and B  
B. B only            D. Neither A nor B
3. Which of the following statements about NiMH cells is NOT true?  
A. When a NiMH cell discharges, hydrogen moves from the anode to the cathode electrode.  
B. Nickel-metal hydride batteries have an anode electrode that contains nickel hydroxide.  
C. The alkaline electrolyte has no active role in the chemical reaction.  
D. The plates are separated by a sheet of fine fibers saturated with potassium hydroxide.



4. The current capacity rating of the battery is being discussed.  
*Technician A* says the amount of electrical energy that a battery is capable of producing depends on the size, weight, and active area of the plates.  
*Technician B* says the current capacity rating of the battery depends on the types of materials used in the construction of the battery.  
 Who is correct?  
 A. A only                      C. Both A and B  
 B. B only                      D. Neither A nor B
5. The construction of the battery is being discussed.  
*Technician A* says the 12-volt battery consists of positive and negative plates connected in parallel.  
*Technician B* says the 12-volt battery consists of six cells wired in series.  
 Who is correct?  
 A. A only                      C. Both A and B  
 B. B only                      D. Neither A nor B
6. Which of the following statements about battery ratings is true?  
 A. The ampere-hour rating is defined as the amount of steady current that a fully charged battery can supply for 1 hour at 80°F (26.7°C) without the cell voltage falling below a predetermined voltage.  
 B. The cold cranking amps rating represents the number of amps that a fully charged battery can deliver at 0°F (−17.7°C) for 30 seconds while maintaining a voltage above 9.6 volts for a 12V battery.  
 C. The cranking amp rating expresses the number of amperes a battery can deliver at 32°F (0°C) for 30 seconds and maintain at least 1.2 volts per cell.  
 D. The reserve capacity rating expresses the number of amperes a fully charged battery at 80°F can supply before the battery's voltage falls below 10.5 volts.
7. Battery terminology is being discussed.  
*Technician A* says grid growth is a condition where the grid grows little metallic fingers that extend through the separators and short out the plates.  
*Technician B* says deep cycling is discharging the battery almost completely before recharging it.  
 Who is correct?  
 A. A only                      C. Both A and B  
 B. B only                      D. Neither A nor B
8. Battery rating methods are being discussed.  
*Technician A* says the ampere-hour is determined by the load in amperes a battery is able to deliver for 30 seconds at 0°F (−17.7°C) without terminal voltage falling below 7.2 volts for a 12-volt battery.  
*Technician B* says the cold cranking rating is the amount of steady current that a fully charged battery can supply for 20 hours at 80°F (26.7°C) without battery voltage falling below 10.5 volts.  
 Who is correct?  
 A. A only                      C. Both A and B  
 B. B only                      D. Neither A nor B
9. The hybrid battery is being discussed.  
*Technician A* says the hybrid battery can withstand six deep cycles and still retain 100% of its original reserve capacity.  
*Technician B* says the grid construction of the hybrid battery consists of approximately 2.75% antimony alloy on the positive plates and a calcium alloy on the negative plates.  
 Who is correct?  
 A. A only                      C. Both A and B  
 B. B only                      D. Neither A nor B
10. *Technician A* says battery polarity must be observed when connecting the battery cables.  
*Technician B* says the battery must be secured in the vehicle to prevent internal damage and the possibility of shorting across the terminals if it tips.  
 Who is correct?  
 A. A only                      C. Both A and B  
 B. B only                      D. Neither A nor B

# Chapter 6

## STARTING SYSTEMS AND MOTOR DESIGNS

### UPON COMPLETION AND REVIEW OF THIS CHAPTER, YOU SHOULD BE ABLE TO UNDERSTAND AND DESCRIBE:

- The purpose of the starting system.
- The components of the starting system.
- The principle of operation of the DC motor.
- The purpose and operation of the armature.
- The purpose and operation of the field coil.
- The differences between the types of magnetic switches used.
- The differences between starter drive mechanisms.
- The differences between the positive engagement and solenoid shift starter.
- The operation and features of the permanent magnet starter.
- The principles of operation of the three-phase AC motor.
- The purpose of the inverter module.
- Explain the operating principles of integrated starter generator (ISG) systems.

### INTRODUCTION

The internal combustion engine must be rotated before it will run under its own power. The starting system is a combination of mechanical and electrical parts that work together to start the engine. The starting system is designed to change the electrical energy, which is being stored in the battery, into mechanical energy. To accomplish this conversion, a starter or cranking motor is used. The starting system includes the following components:

1. Battery.
2. Cable and wires.
3. Ignition switch.
4. Starter solenoid or relay.
5. Starter motor.
6. Starter drive and flywheel ring gear.
7. Starter safety switch.

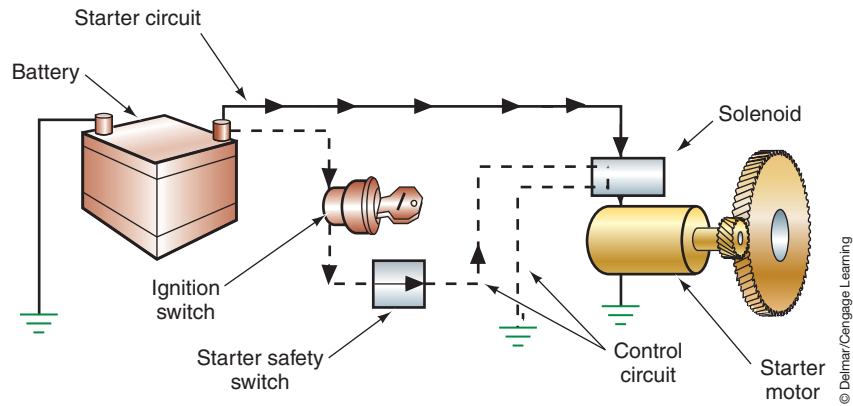
Components in a simplified cranking system circuit are shown (Figure 6-1). This chapter examines both this circuit and the fundamentals of electric motor operation.

### DIRECT-CURRENT MOTOR PRINCIPLES

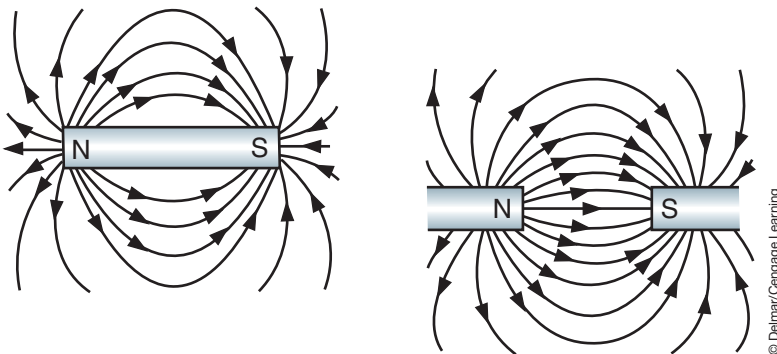
DC motors use the interaction of magnetic fields to convert the electrical energy into mechanical energy. Magnetic lines of force flow from the north pole to the south pole of a magnet (Figure 6-2). If a current-carrying conductor is placed within the magnetic field, two fields

**Shop Manual**  
Chapter 6, page 229

**Shop Manual**  
Chapter 6, page 235



**FIGURE 6-1** Major components of the starting system. The solid line represents the starting (cranking) circuit and the dashed line indicates the starter control circuit.

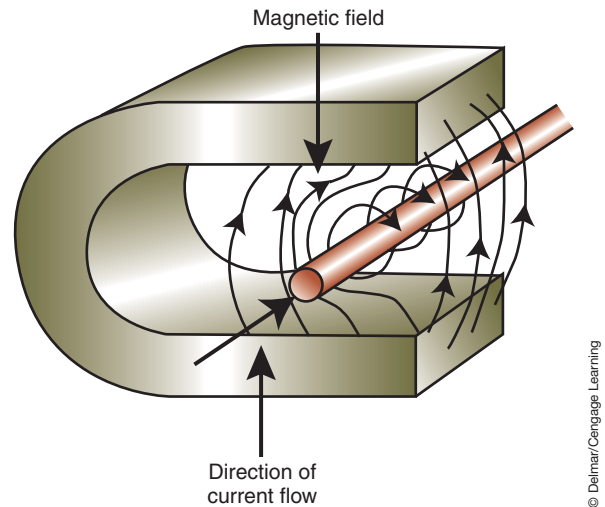


**FIGURE 6-2** Magnetic lines of force flow from the north pole to the south pole.



## A BIT OF HISTORY

In the early days of the automobile, the vehicle did not have a starter motor. The operator had to use a starting crank to turn the engine by hand. Charles F. Kettering invented the first electric “self-starter,” which was developed and built by the Delco Electrical Plant. The self-starter first appeared on the 1912 Cadillac and was actually a combination starter and generator.

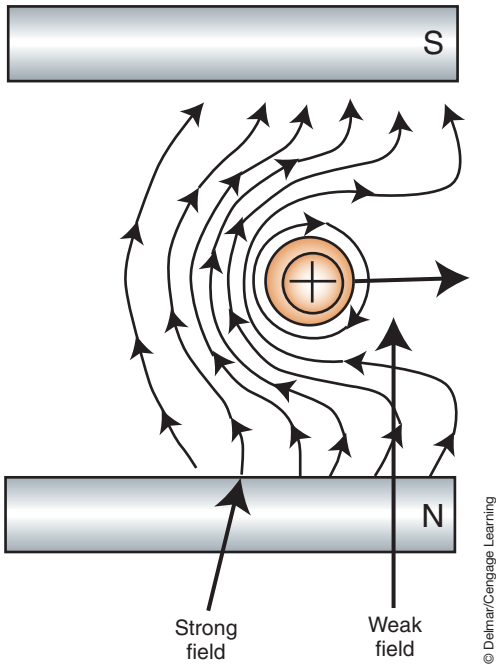


**FIGURE 6-3** Interaction of two magnetic fields.

will be present (Figure 6-3). On the left side of the conductor, the lines of force are in the same direction. This will concentrate the flux density of the lines of force on the left side. This will produce a strong magnetic field because the two fields will reinforce each other. The lines of force oppose each other on the right side of the conductor. This results in a weaker magnetic field. The conductor will tend to move from the strong field to the weak field (Figure 6-4). This principle is used to convert electrical energy into mechanical energy in a starter motor by electromagnetism.

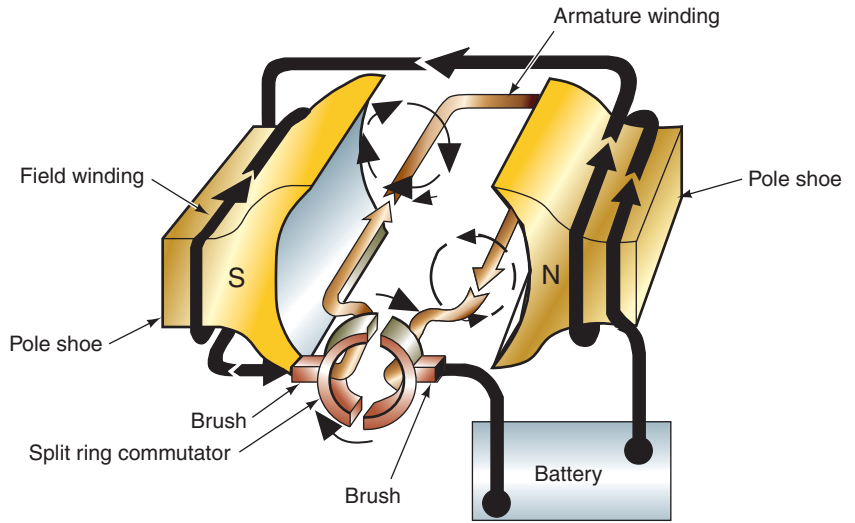
A simple electromagnet-style starter motor is shown (Figure 6-5). The inside windings are called the **armature**. The armature is the moveable component of the motor that consists of a conductor wound around a laminated iron core. It is used to create a magnetic field. The armature rotates within the stationary outside windings, called the **field coils**, which has windings coiled around **pole shoes** (Figure 6-6). Field coils are heavy copper wire wrapped around an iron core to form an electromagnet. Pole shoes are made of high-magnetic permeability material to help concentrate and direct the lines of force in the field assembly.

When current is applied to the field coils and the armature, both produce magnetic flux lines (Figure 6-7). The direction of the windings will place the left pole at a south polarity and



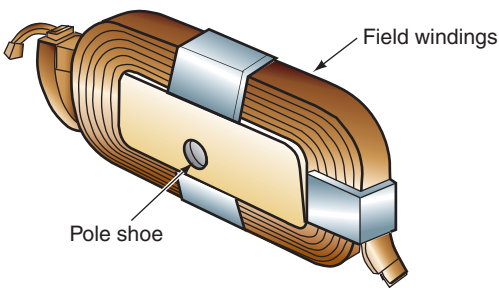
**FIGURE 6-4** Conductor movement in a magnetic field.

© Delmar/Cengage Learning



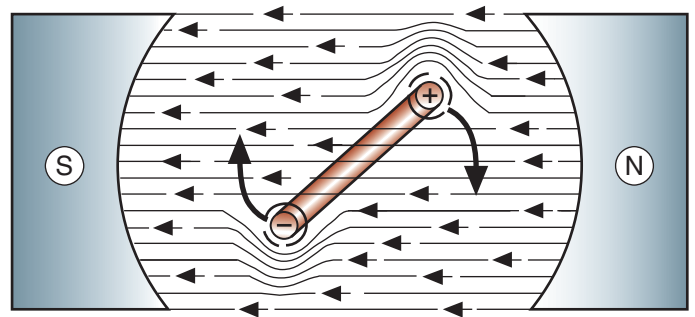
**FIGURE 6-5** Simple electromagnetic motor.

© Delmar/Cengage Learning



**FIGURE 6-6** Field coil wound around a pole shoe.

© Delmar/Cengage Learning



**FIGURE 6-7** Rotation of the conductor is in the direction of the weaker field.

© Delmar/Cengage Learning

the right side at a north polarity. The lines of force move from north to south in the field. In the armature, the flux lines circle in one direction on one side of the loop and in the opposite direction on the other side. Current will now set up a magnetic field around the loop of wire, which will interact with the north and south fields and put a turning force on the loop. This force will cause the loop to turn in the direction of the weaker field. However, the armature is limited in how far it is able to turn. When the armature is halfway between the shoe poles, the fields balance one another. The point at which the fields are balanced is referred to as the **static neutral point**.

For the armature to continue rotating, the current flow in the loop must be reversed. To accomplish this, a split-ring **commutator** is in contact with the ends of the armature loops. The commutator is a series of conducting segments located around one end of the armature. Current enters and exits the armature through a set of **brushes** that slide over the commutator's sections. Brushes are electrically conductive sliding contacts, usually made of copper and carbon. As the brushes pass over one section of the commutator to another, the current flow in the armature is reversed. The position of the magnetic fields are the same. However, the direction of current flow through the loop has been reversed. This will continue until the current flow is turned off.

**Shop Manual**  
Chapter 6, page 252

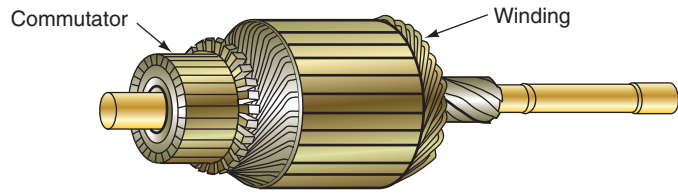


FIGURE 6-8 Starter armature.

© Delmar/Cengage Learning

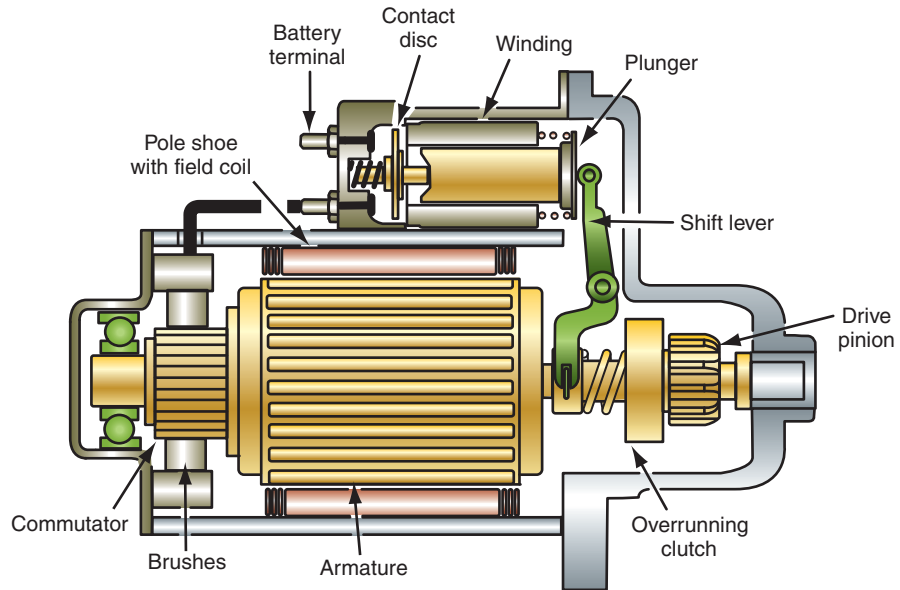


FIGURE 6-9 Starter and solenoid components.

© Delmar/Cengage Learning

A single-loop motor would not produce enough torque to rotate an engine. Power can be increased by the addition of more loops or pole shoes. An armature with its many windings, with each loop attached to corresponding commutator sections, is shown (Figure 6-8). In a typical starter motor (Figure 6-9) there are four brushes that make the electrical connections to the commutator. Two of the brushes are grounded to the starter motor frame and two are insulated from the frame. Also, the armature is supported by bushings at both ends.

## Armature

The armature is constructed with a laminated core made of several thin iron stampings that are placed next to each other (Figure 6-10). **Laminated construction** is used because, in a solid iron core, the magnetic fields would generate **eddy currents**. These are counter voltages induced in a core. They cause heat to build up in the core and waste energy. By using laminated construction, eddy currents in the core are minimized.

The slots on the outside diameter of the laminations hold the armature windings. The windings loop around the core and are connected to the commutator. Each commutator segment is insulated from the adjacent segments. A typical armature can have more than 30 commutator segments.

A steel shaft is fitted into the center hole of the core laminations. The commutator is insulated from the shaft.

Two basic winding patterns are used in the armature: lap winding and wave winding. In the lap winding, the two ends of the winding are connected to adjacent commutator segments (Figure 6-11). In this pattern, the wires passing under a pole field have their current flowing in the same direction.

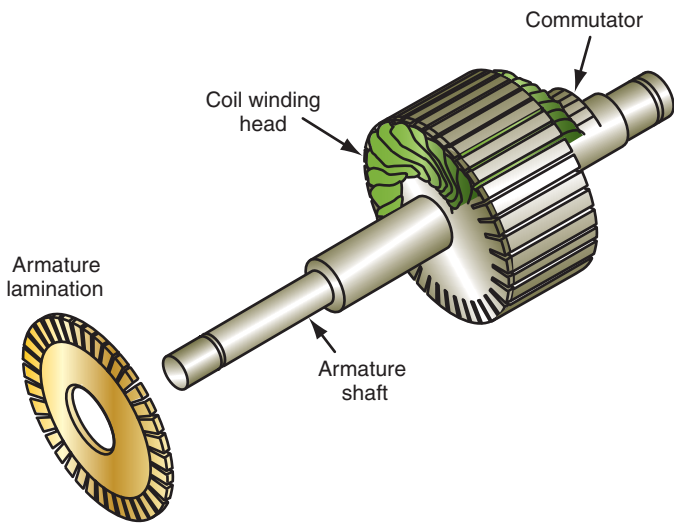


FIGURE 6-10 Lamination construction of a typical motor armature.

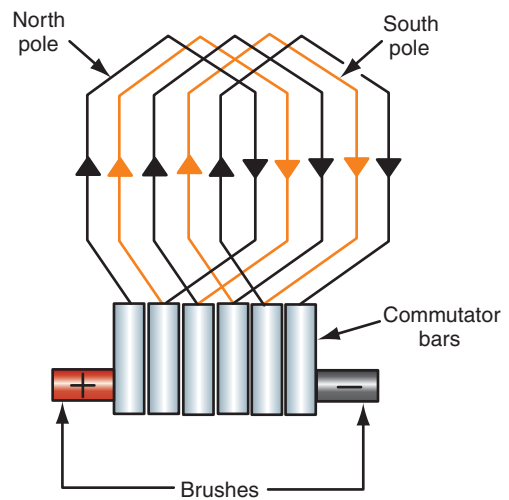


FIGURE 6-11 Lap winding diagram.

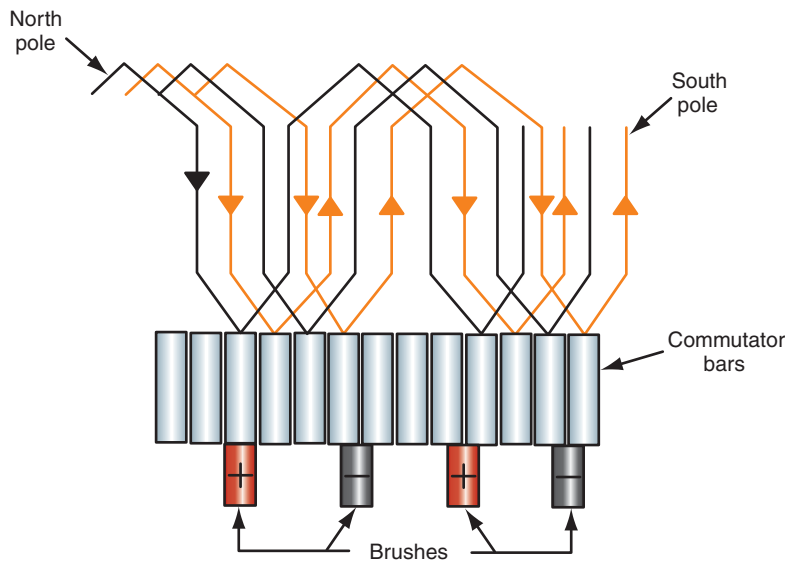


FIGURE 6-12 Wave-wound armature.

In the wave-winding pattern, each end of the winding connects to commutator segments that are 90 or 180 degrees apart (Figure 6-12). In this pattern design, some windings will have no current flow at certain positions of armature rotation. This occurs because the segment ends of the winding loop are in contact with brushes that have the same polarity. The wave-winding pattern is the most commonly used due to its lower resistance.

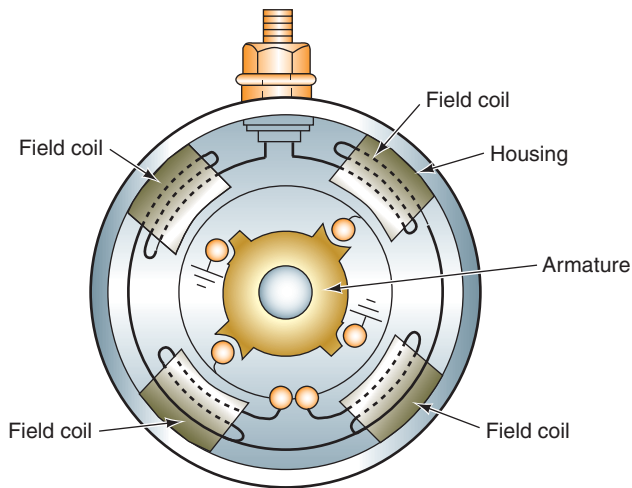
## Field Coils

The field coils are electromagnets constructed of wire ribbons or coils wound around a pole shoe. The pole shoes are constructed of heavy iron. The field coils are attached to the inside of the starter housing (Figure 6-13). Most starter motors use four field coils. The iron pole shoes and the iron starter housing work together to increase and concentrate the field strength of the field coils (Figure 6-14).

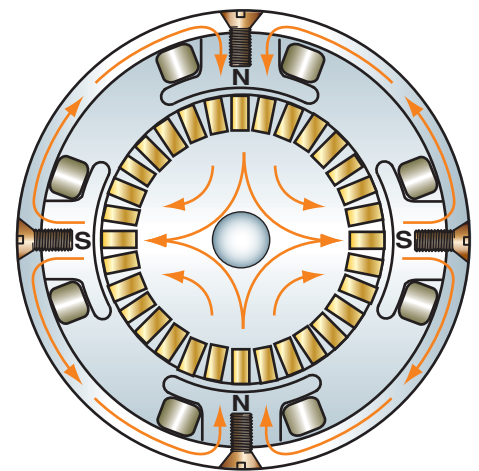
When current flows through the field coils, strong stationary electromagnetic fields are created. The fields have a north and south magnetic polarity based on the direction the windings are wound around the pole shoes. The polarity of the field coils alternate to produce opposing magnetic fields.

**Shop Manual**  
Chapter 6, page 251





**FIGURE 6-13** Field coils mounted to the inside of starter housing.



**FIGURE 6-14** Magnetic fields in a 4-pole starter motor.

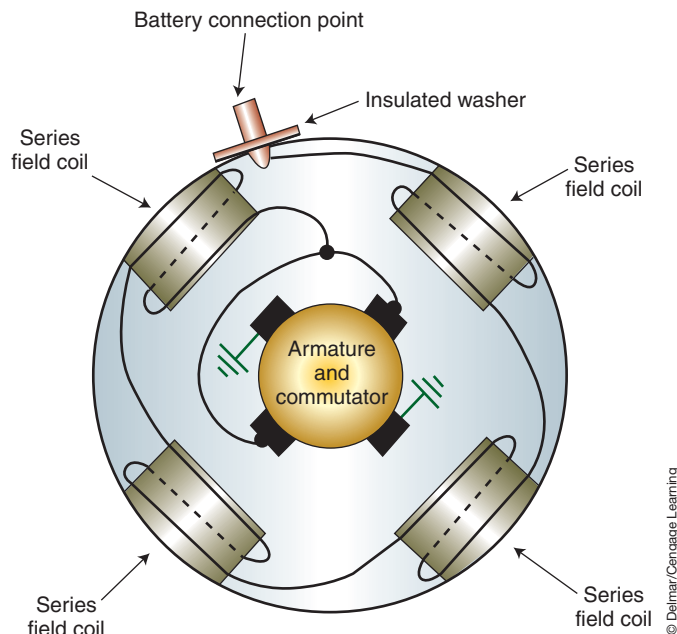
In any DC motor, there are three methods of connecting the field coils to the armature: in series, in parallel (shunt), and a compound connection that uses both series and shunt coils.

## DC MOTOR FIELD WINDING DESIGNS

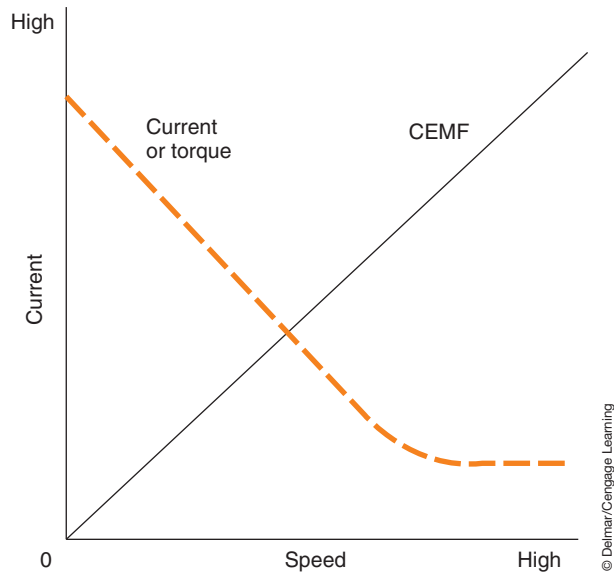
The field windings and armature of the DC motor can be wired in various ways. The motor design is referenced by the method these two components are wired together. In addition, many motors are using permanent magnet fields. Also, many newer motors are designed to be brushless.

### Series-Wound Motors

Most starter motors are series-wound with current flowing first to the field windings, then to the brushes, through the commutator and the armature winding contacting the brushes at that time, then through the grounded brushes back to the battery source (Figure 6-15). This design permits all of the current that passes through the field coils to also pass through the armature.



**FIGURE 6-15** A series-wound starter motor.



**FIGURE 6-16** Graph illustrating the relationship between CEMF, starter motor speed, and current draw. As speed increases so does CEMF, reducing current draw and torque.

© Delmar/Cengage Learning

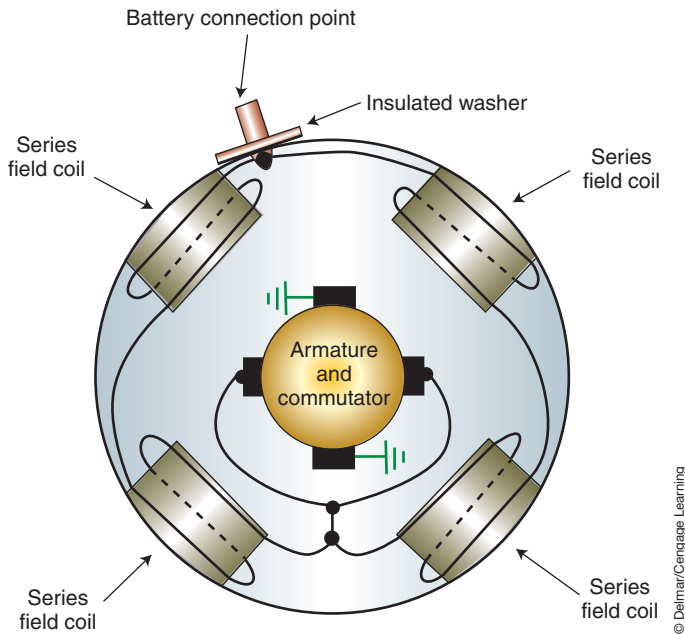
A series-wound motor will develop its maximum torque output at the time of initial start. As the motor speed increases, the torque output of the motor will decrease. This decrease of torque output is the result of **counter electromotive force (CEMF)** caused by self-induction. Since a starter motor has a wire loop rotating within a magnetic field, it will generate an electrical voltage as it spins. This induced voltage will be opposite the battery voltage that is pushing the current through the starter motor. The faster the armature spins, the greater the amount of induced voltage that is generated. This results in less current flow through the starter from the battery as the armature spins faster. Figure 6-16 shows the relationship between starter motor speed and CEMF. Notice that, at 0 (zero) rpm, CEMF is also at 0 (zero). At this time, maximum current flow from the battery through the starter motor will be possible. As the motor spins faster, CEMF increases and current decreases. Since current decreases, the amount of rotating force (torque) also decreases.

## Shunt-Wound Motors

Electric motors, or **shunt** motors, have the field windings wired in parallel across the armature (Figure 6-17). *Shunt* means there is more than one path for current to flow. A shunt-wound field is used to limit the speed that the motor can turn. A shunt motor does not decrease in its torque output as speeds increase. This is because the CEMF produced in the armature does not decrease the field coil strength. Due to a shunt motor's inability to produce high torque, it is not typically used as a starter motor. However, shunt motors may be found as wiper motors, power window motors, power seat motors, and so on.

## Compound Motors

In a **compound motor** most of the field coils are connected to the armature in series and one field coil is connected in parallel with the battery and the armature (Figure 6-18). This configuration allows the compound motor to develop good starting torque and constant operating speeds. The field coil that is shunt wound is used to limit the speed of the starter motor. Also, on Ford's positive engagement starters, the shunt coil is used to engage the starter drive. This is possible because the shunt coil is energized as soon as battery voltage is sent to the starter.



**FIGURE 6-17** A shunt-wound (parallel) starter motor.

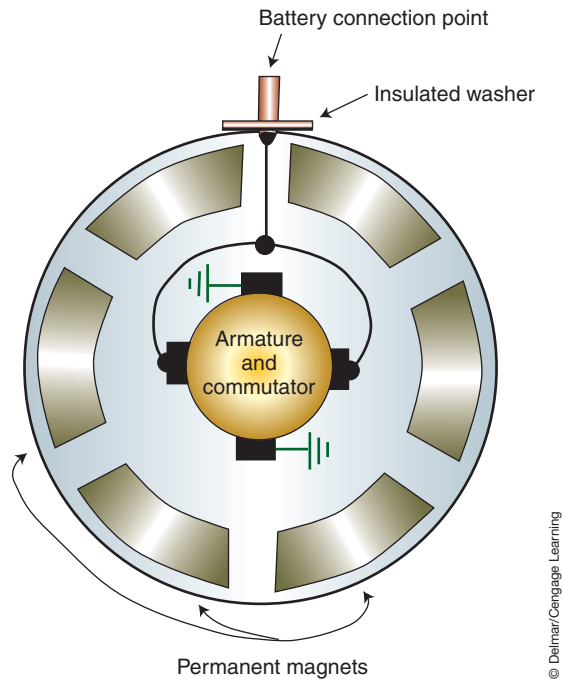


**FIGURE 6-18** A compound motor uses both series and shunt coils.

## Permanent Magnet Motors

Most newer vehicles have starter motors that use permanent magnets in place of the field coils (Figure 6-19). These motors are also used in many different applications. When a permanent magnet is used instead of coils, there is no field circuit in the motor. By eliminating this circuit, potential electrical problems are also eliminated, such as field-to-housing shorts. Another advantage to using permanent magnets is weight savings; the weight of a typical starter motor is reduced by 50%. Most permanent magnet starters are gear-reduction-type starters.

Multiple permanent magnets are positioned in the housing around the armature. These permanent magnets are an alloy of boron, neodymium, and iron. The field strength of these magnets is much greater than typical permanent magnets. The operation of these motors is the same as other electric motors, except there is no field circuit or windings.



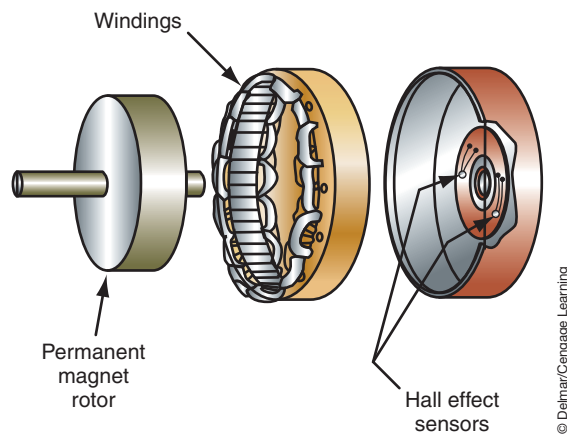
**FIGURE 6-19** A permanent magnet motor has only an armature circuit, as the field is created by strong permanent magnets.

## Brushless Motors

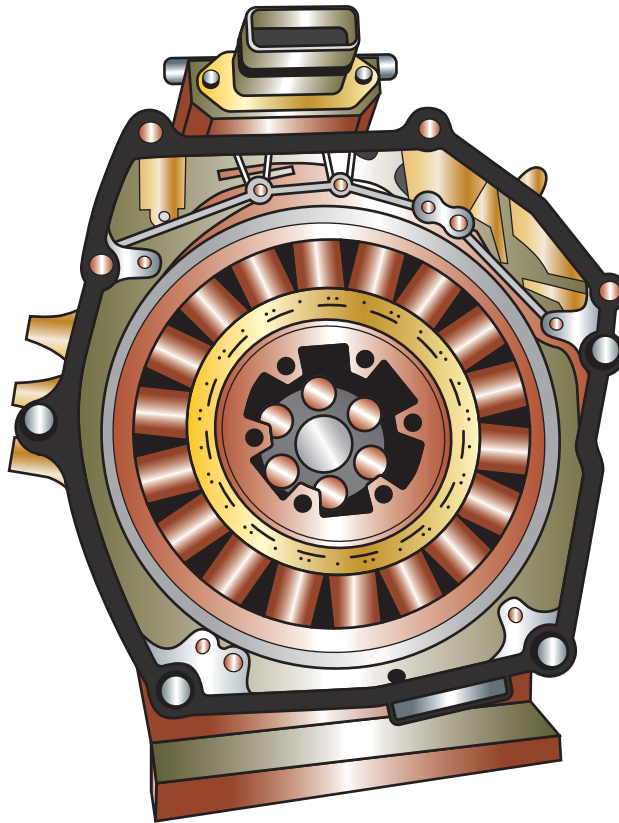
The brushless motor uses a permanent magnet rotor and electromagnet field windings (Figure 6-20). Since the motor design is brushless, the potential for arcing is decreased and longer service life is expected. In addition, arcing can cause electromagnetic interference (EMI) that can adversely affect electronic systems. High output brushless DC motors are used in some HEV-drive vehicles (Figure 6-21).

Control of the stator is by an electronic circuit that switches the current flow as needed to keep the rotor turning. Power transistors that are wired as “H” gates reverse current flow according to the position of the rotor. Motor speed can be controlled by PWM of the driver circuits. Rotor position is usually monitored by the use of Hall-effect sensors. However, rotor

The field windings of a brushless motor are also called the stator.



**FIGURE 6-20** Components of a brushless DC motor. The hall-effect sensor is used to determine rotor position.



© Delmar/Cengage Learning

**FIGURE 6-21** Brushless motor used by Honda in some of their HEVs.

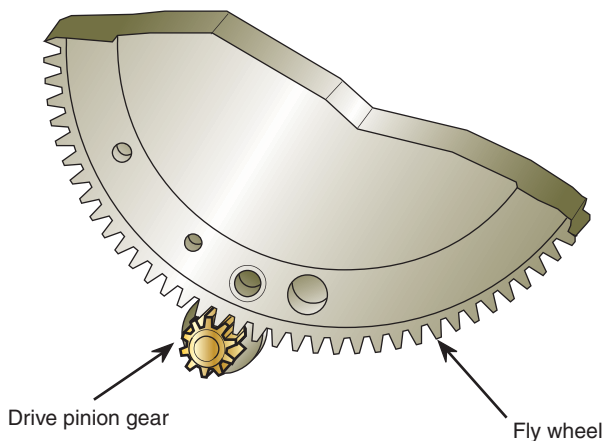
position can also be determined by monitoring the CEMF that is present in stator windings that are not energized.

## STARTER DRIVES

### Shop Manual

Chapter 6, page 253

The **starter drive** is the part of the starter motor that engages the armature to the engine flywheel ring gear. A starter drive includes a pinion gear set that meshes with the flywheel ring gear on the engine's crankshaft (Figure 6-22). To prevent damage to the pinion gear or the ring gear, the pinion gear must mesh with the ring gear before the starter motor rotates. To help assure smooth engagement, the ends of the pinion gear teeth are tapered (Figure 6-23). Also,



© Delmar/Cengage Learning

**FIGURE 6-22** Starter drive pinion gear is used to turn the engine's flywheel.



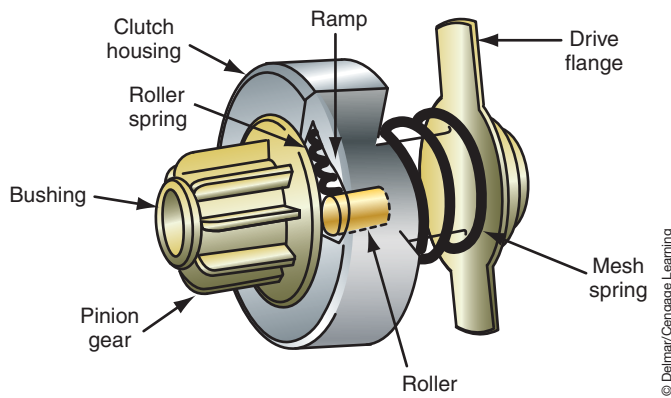
© Delmar/Cengage Learning

**FIGURE 6-23** The pinion gear teeth are tapered to allow for smooth engagement.

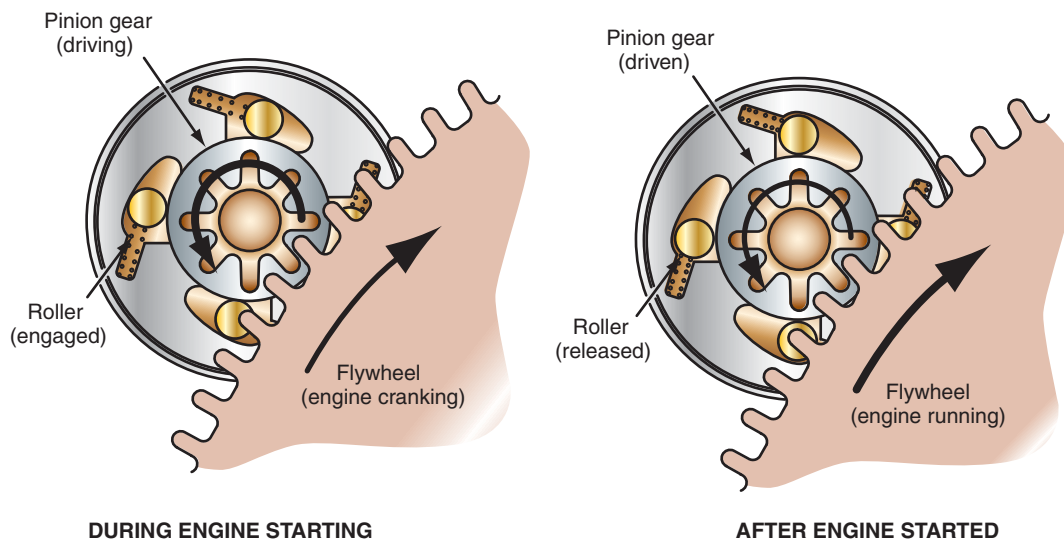
the action of the armature must always be from the motor to the engine. The engine must not be allowed to spin the armature. The **ratio** of the number of teeth on the ring gear and the starter drive pinion gear is usually between 15:1 and 20:1. This means the starter motor is rotating 15 to 20 times faster than the engine. The ratio of the starter drive is determined by dividing the number of teeth on the drive gear (pinion gear) into the number of teeth on the driven gear (flywheel). Normal cranking speed for the engine is about 200 rpm. If the starter drive had a ratio of 18:1, the starter would be rotating at a speed of 3,600 rpm. If the engine started and was accelerated to 2,000 rpm, the starter speed would increase to 36,000 rpm. This would destroy the starter motor if it was not disengaged from the engine.

The most common type of starter drive is the **overrunning clutch**. The overrunning clutch is a roller-type clutch that transmits torque in one direction only and freewheels in the other direction. This allows the starter motor to transmit torque to the ring gear but prevents the ring gear from transferring torque to the starter motor.

In a typical overrunning-type clutch (Figure 6-24), the clutch housing is internally splined to the starter armature shaft. The drive pinion turns freely on the armature shaft within the clutch housing. When torque is transmitted through the armature to the clutch housing, the spring-loaded rollers are forced into the small ends of their tapered slots (Figure 6-25). They are then wedged tightly against the pinion barrel. The pinion barrel and clutch housing are now locked together; torque is transferred through the starter motor to the ring gear and engine.



**FIGURE 6-24** Overrunning clutch starter drive.



**FIGURE 6-25** When the armature turns, it locks the rollers into the tapered notch.





## A BIT OF HISTORY

The integrated key starter switch was introduced in 1949 by Chrysler. Before this, the key turned the system on and the driver pushed a starter button.

**Shop Manual**  
Chapter 6, pages  
240, 242

When the engine starts and is running under its own power, the ring gear attempts to drive the pinion gear faster than the starter motor. This unloads the clutch rollers and releases the pinion gear to rotate freely around the armature shaft.

## CRANKING MOTOR CIRCUITS

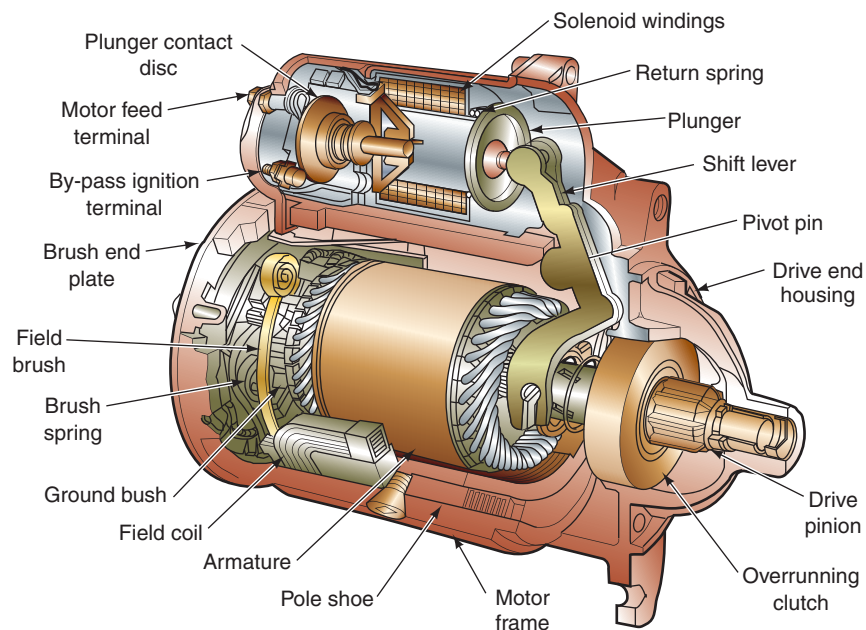
The starting system of the vehicle consists of two circuits: the starter control circuit and the motor feed circuit. These circuits are separate but related. The control circuit consists of the starting portion of the ignition switch, the starting safety switch (if applicable), and the wire conductor to connect these components to the relay or solenoid. The motor feed circuit consists of heavy battery cables from the battery to the relay and the starter or directly to the solenoid if the starter is so equipped.

## STARTER CONTROL CIRCUIT COMPONENTS

### Magnetic Switches

The starter motor requires large amounts of current (up to 300 amperes) to generate the torque needed to turn the engine. The conductors used to carry this amount of current (battery cables) must be large enough to handle the current with very little voltage drop. It would be impractical to place a conductor of this size into the wiring harness to the ignition switch. To provide control of the high current, all starting systems contain some type of magnetic switch. There are two basic types of magnetic switches used: the solenoid and the relay.

**Starter-Mounted Solenoids.** As discussed in Chapter 3, a solenoid is an electromagnetic device that uses the movement of a plunger to exert a pulling or holding force. In the solenoid-actuated starter system, the solenoid is mounted directly on top of the starter motor (Figure 6-26). The solenoid switch on a starter motor performs two functions: It closes the circuit between the battery and the starter motor. Then it shifts the starter motor pinion gear into mesh with the ring gear. This is accomplished by a linkage between the solenoid plunger and the shift lever on the starter motor. In the past, the most common method of energizing the solenoid was directly from the battery through the ignition switch. However, most of



**FIGURE 6-26** Solenoid-operated starter has the solenoid mounted directly on top of the motor.

© Delmar/Cengage Learning

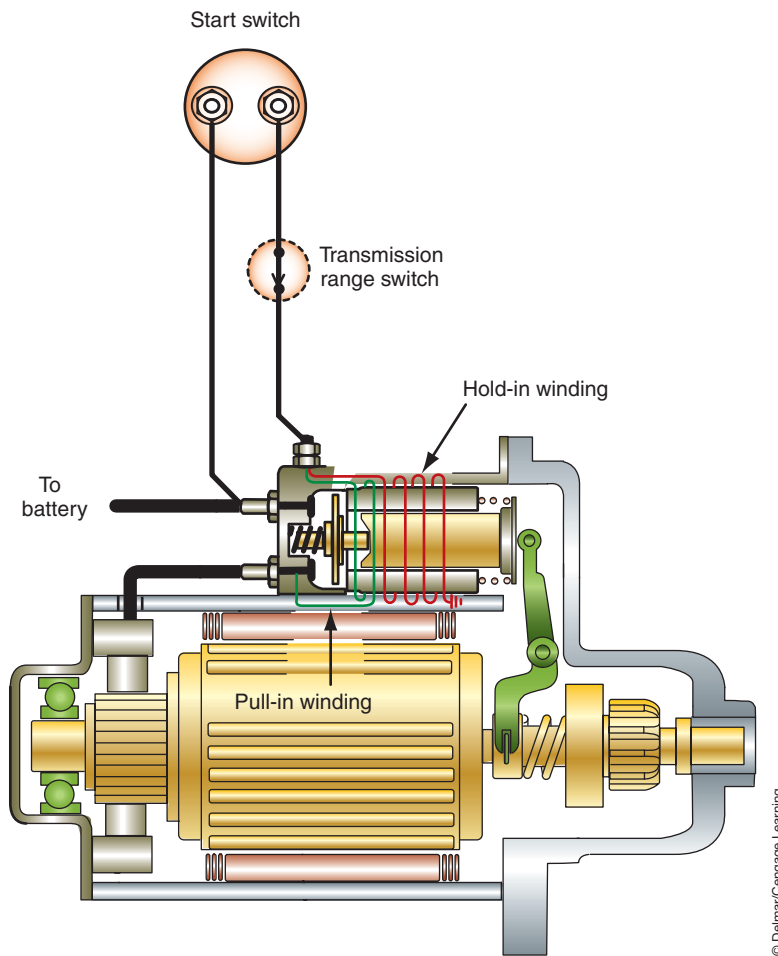
today's vehicles use a starter relay in conjunction with a solenoid. The relay is used to reduce the amount of current flow through the ignition switch and is usually controlled by the powertrain control module (PCM). This system will be discussed later in this chapter.

When the circuit is closed and current flows to the solenoid, current from the battery is directed to the **pull-in** and **hold-in windings** (Figure 6-27). Because it may require up to 50 amperes to create a magnetic force large enough to pull the plunger in, both windings are energized to create a combined magnetic field that pulls the plunger. Once the plunger is moved, the current required to hold the plunger is reduced. This allows the current that was used to pull the plunger in to be used to rotate the starter motor.

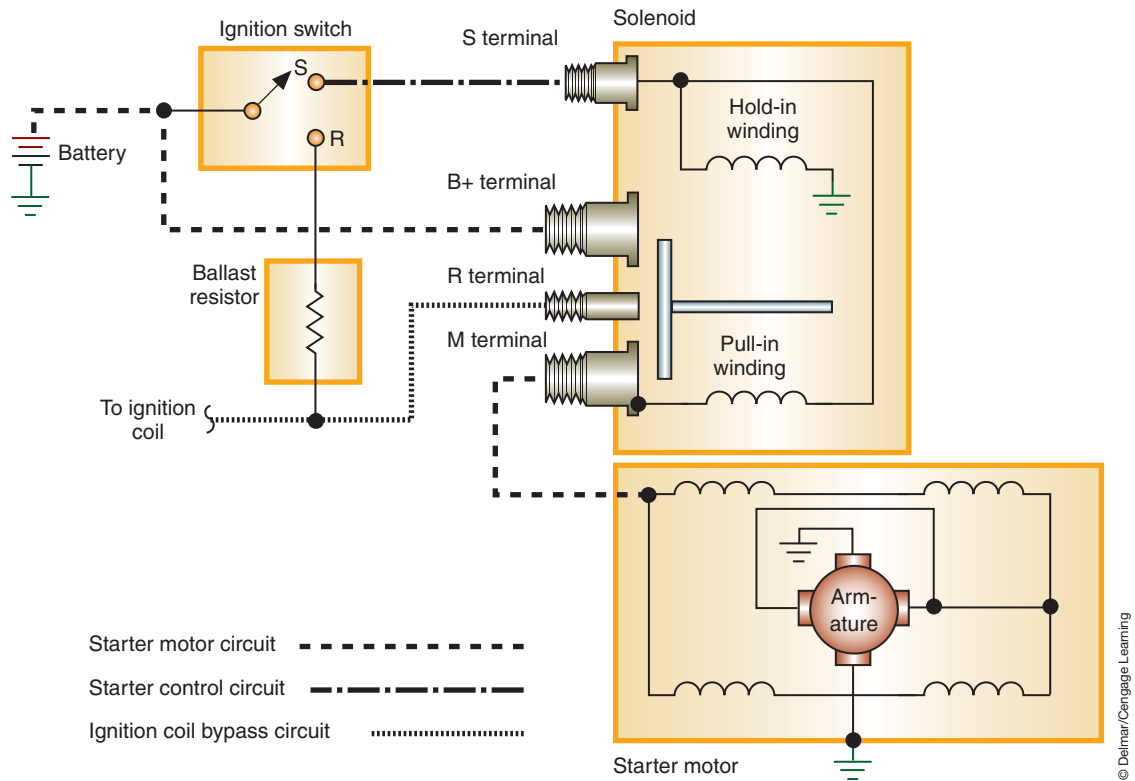
When the ignition switch is placed in the START position, voltage is applied to the S terminal of the solenoid (Figure 6-28). The hold-in winding has its own ground to the case of the solenoid. The pull-in winding's ground is through the starter motor. Current will flow through both windings to produce a strong magnetic field. When the plunger is moved into contact with the main battery and motor terminals, the pull-in winding is de-energized. The pull-in winding is not energized because the contact places battery voltage on both sides of the coil (Figure 6-29). The current that was directed through the pull-in winding is now sent to the motor.

Because the contact disc does not close the circuit from the battery to the starter motor until the plunger has moved the shift lever, the pinion gear is in full mesh with the flywheel before the armature starts to rotate.

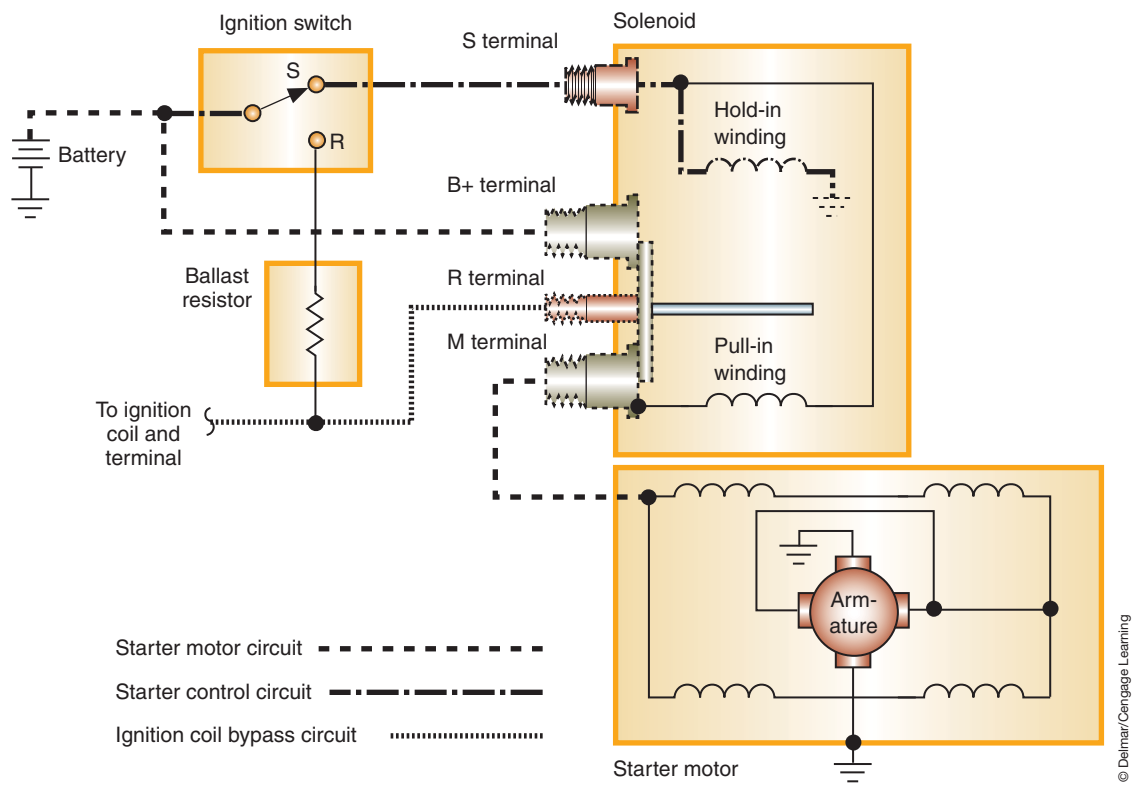
The two windings of the solenoid are called the **pull-in** and the **hold-in windings**. Their names explain their functions.



**FIGURE 6-27** The solenoid uses two windings. Both are energized to draw the plunger, then only the hold-in winding is used to hold the plunger in position.



**FIGURE 6-28** Schematic of solenoid operated starter motor circuit.



**FIGURE 6-29** Once the contact disc closes the terminals, the hold-in winding is the only one that is energized.

After the engine is started, releasing the key to the RUN position opens the control circuit. Voltage no longer is supplied to the hold-in windings, and the return spring causes the plunger to return to its neutral position.

In Figures 6-28 and 6-29, an R terminal is illustrated. This terminal provides current to the ignition bypass circuit that is used to provide full battery voltage to the ignition coil while the engine is cranking. This circuit bypasses the ballast resistor. The bypass circuit is not used on most ignition systems today.

A common problem with the control circuit is that low system voltage or an open in the hold-in windings will cause an oscillating action to occur. The combination of the pull-in winding and the hold-in winding is sufficient to move the plunger. However, once the contacts are closed, there is insufficient magnetic force to hold the plunger in place. This condition is recognizable by a series of clicks when the ignition switch is turned to the START position. Before replacing the solenoid, check the battery condition; a low battery charge will cause the same symptom.

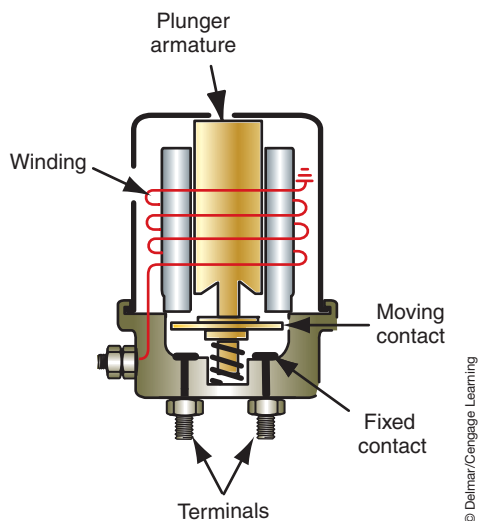
**AUTHOR'S NOTE:** Some manufacturers use a starter relay in conjunction with a solenoid relay. The relay is used to reduce the amount of current flow through the ignition switch.

**Remote Solenoids.** Some manufacturers use a starter solenoid that is mounted near the battery on the fender well or radiator support (Figure 6-30). Unlike the starter-mounted solenoid, the remote solenoid does not move the pinion gear into mesh with the flywheel ring gear.

When the ignition switch is turned to the START position, current is supplied through the switch to the solenoid windings. The windings produce a magnetic field that pulls the moveable core into contact with the internal contacts of the battery and starter terminals (Figure 6-31). With the contacts closed, full battery current is supplied to the starter motor.

A secondary function of the starter relay is to provide for an alternate path for current to the ignition coil during cranking. This is done by an internal connection that is energized by the relay core when it completes the circuit between the battery and the starter motor.

Many manufacturers call the remote solenoid the starter relay.



**FIGURE 6-30** A remote starter solenoid, often referred to as the starter relay.

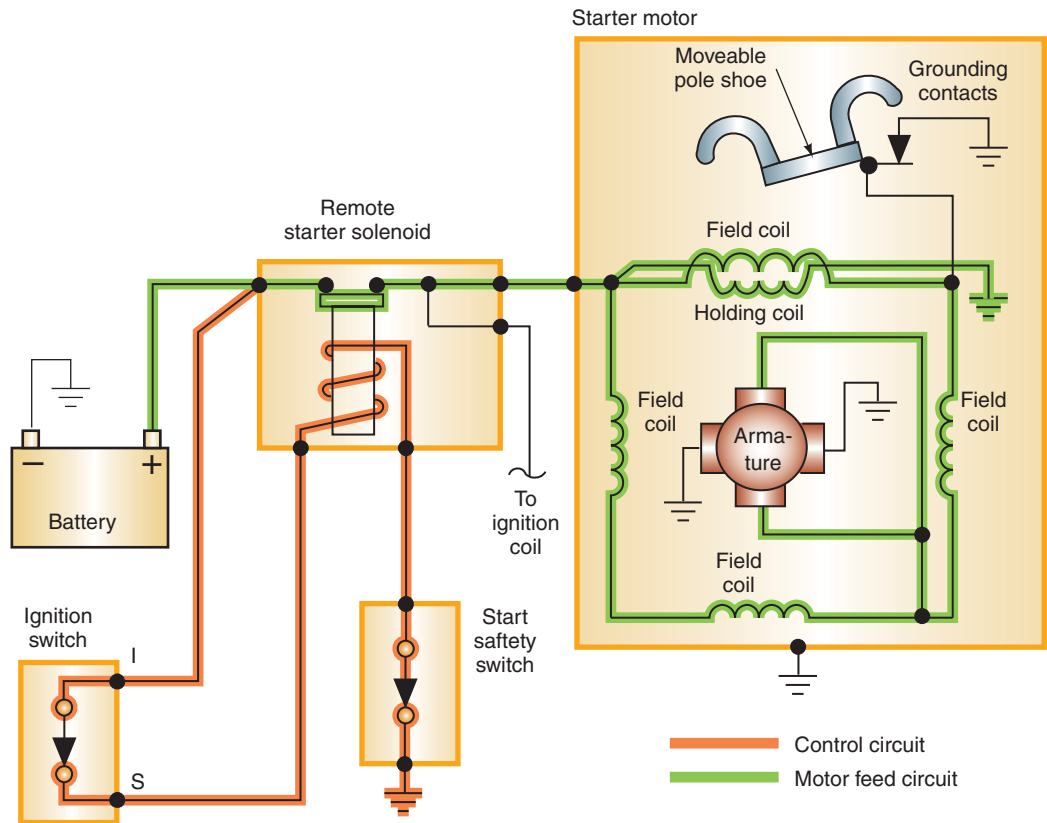


FIGURE 6-31 Current flow when the remote starter solenoid is energized.

© Delmar/Cengage Learning

## Starter Relay Controls

Most modern vehicles will use a starter relay in conjunction with a starter motor–mounted solenoid to control starter motor operation. The relay can be controlled through the ignition switch or by the powertrain control module (PCM).

In a system that uses the ignition switch to control the relay, the switch will usually be installed on the insulated side of the relay control circuit (Figure 6-32). When the ignition switch is turned to the START position, battery voltage is applied to the coil of the relay. Since the relay coil is grounded, the coil is energized and pulls the contacts closed. With the contacts closed, battery voltage is applied to the control side of the starter solenoid. The solenoid operates in the same manner as discussed previously.

In this type of system, a very small wire can be used through the steering column to the ignition switch. This reduces the size of the wiring harness.

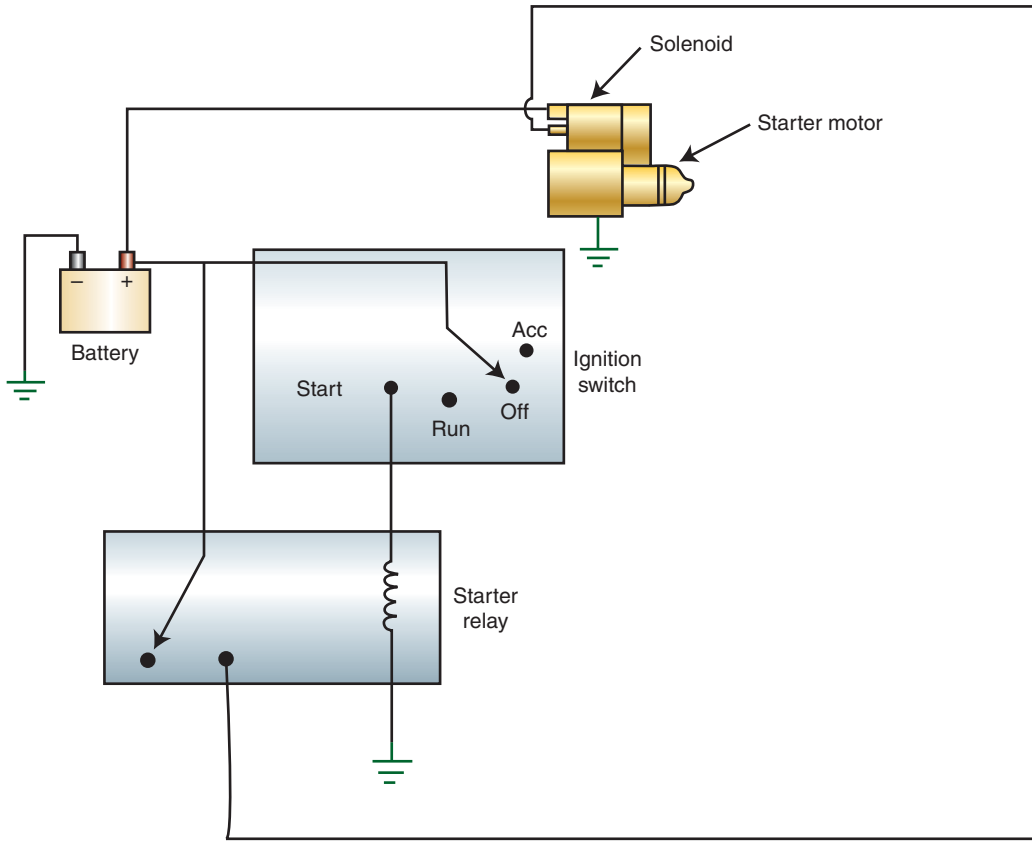
In a PCM-controlled system, the PCM will monitor the ignition switch position to determine if the starter motor should be energized. System operation differs among manufacturers. However, in most systems, the PCM will control the starter relay coil ground circuit (Figure 6-33). Control by the PCM allows the manufacturer to install software commands such as **double start override**, which prevents the starter motor from being energized if the engine is already running, and **sentry key** within the PCM.

## Ignition Switch

The ignition switch is the power distribution point for most of the vehicle's primary electrical systems (Figure 6-34). Most ignition switches have five positions:

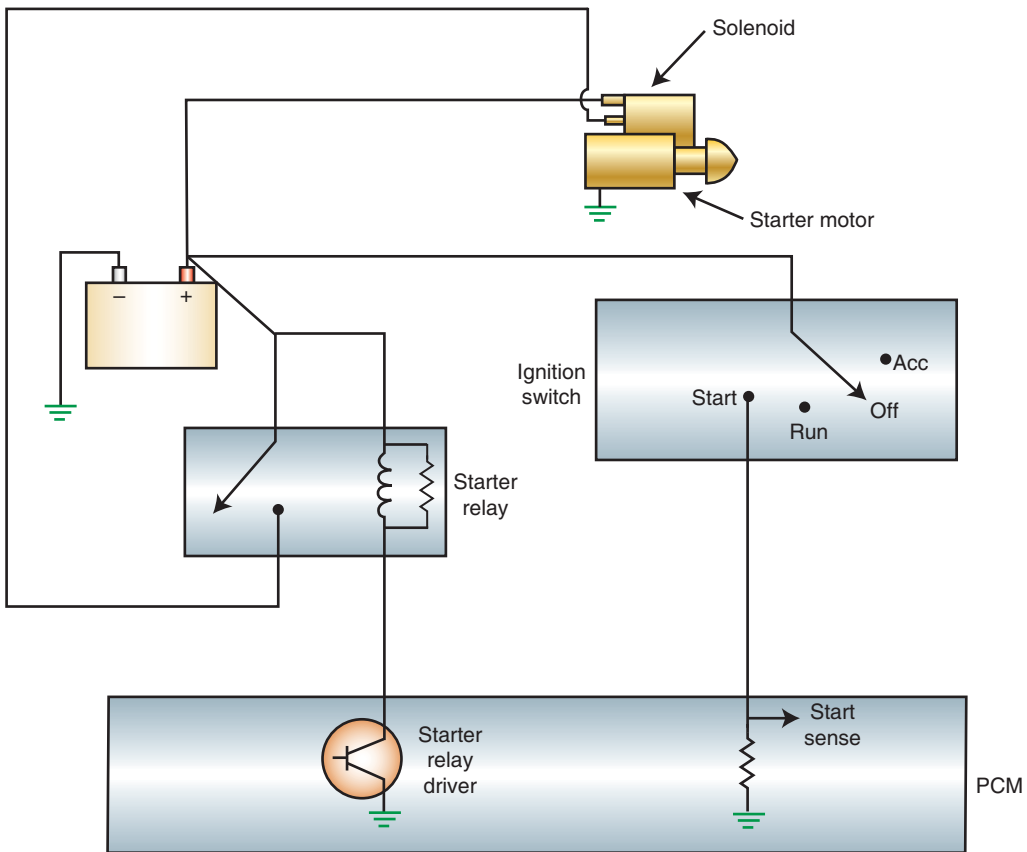
1. **ACCESSORIES:** Supplies current to the vehicle's electrical accessory circuits. It will not supply current to the engine control circuits, starter control circuit, or the ignition system.

**Sentry key** is one of the terms used to describe a sophisticated antitheft system that prevents the engine from starting unless a special key is used.



© Delmar/Cengage Learning

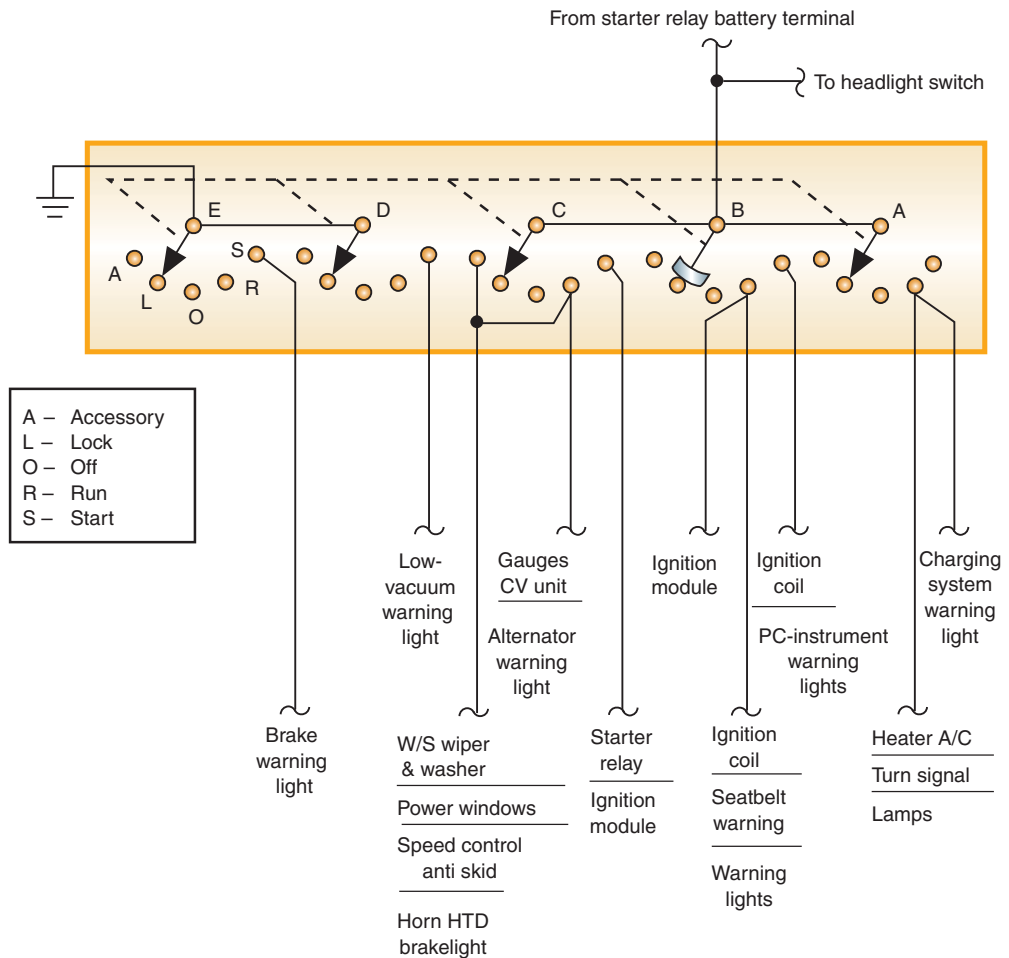
FIGURE 6-32 Starter control circuit using an insulated side relay to control current to the starter solenoid.



© Delmar/Cengage Learning

FIGURE 6-33 Typical PCM starter control circuit.



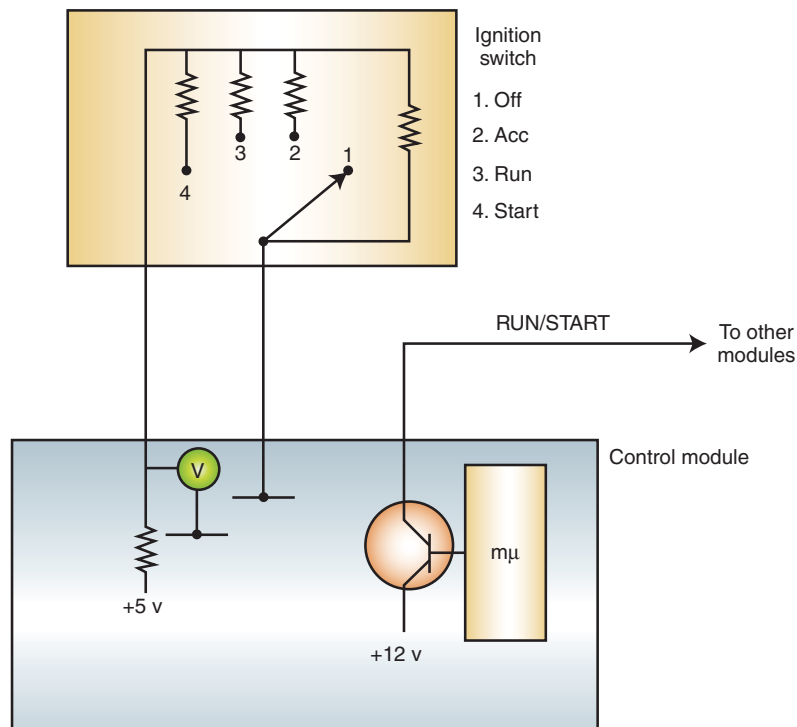


**FIGURE 6-34** Ganged ignition switch.

2. **LOCK:** Mechanically locks the steering wheel and transmission gear selector. All electrical contacts in the ignition switch are open. Most ignition switches must be in this position to insert or remove the key from the cylinder.
3. **OFF:** All circuits controlled by the ignition switch are opened. The steering wheel and transmission gear selector are unlocked.
4. **ON or RUN:** The switch provides current to the ignition, engine controls, and all other circuits controlled by the switch. Some systems will power a chime or light with the key in the ignition switch. Other systems power an antitheft system when the key is removed and turn it off when the key is inserted.
5. **START:** The switch provides current to the starter control circuit, ignition system, and engine control circuits.

The ignition switch is spring loaded in the START position. This momentary contact automatically moves the contacts to the RUN position when the driver releases the key. All other ignition switch positions are detent positions.

Many manufacturers have moved away from the use of ganged ignition switches with their numerous wires to a multiplexed switch (Figure 6-35). The multiplex switch reduces the wires required to determine switch position down to two. The control module then uses a high-side driver to provide other modules their switched battery voltage on the RUN/START circuit. Since the ignition switch is used only as an input, there is no high current flow through the switch and the wire size can be reduced.



**FIGURE 6-35** Multiplex ignition switches require fewer wires than the ganged switch.

© Delmar/Cengage Learning

In some instances, the ignition switch is a node on the bus network. In this case, the ignition switch module communicates the switch positions to all other modules that require this information.

## Starting Safety Switch

The neutral safety switch is used on vehicles equipped with automatic transmissions. It opens the starter control circuit when the transmission shift selector is in any position except PARK or NEUTRAL. The actual location of the neutral safety switch depends on the kind of transmission and the location of the shift lever. Some manufacturers place the switch in the transmission (Figure 6-36).

Vehicles equipped with automatic transmissions require a means of preventing the engine from starting while the transmission is in gear. Without this feature, the vehicle would lunge forward or backward once it was started, causing personal injury or property damage. The normally open neutral safety switch is connected in series in the starting system control circuit and is usually operated by the shift lever. When in the PARK or NEUTRAL position, the switch is closed, allowing current to flow to the starter circuit. If the transmission is in a gear position, the switch is opened and current cannot flow to the starter circuit.

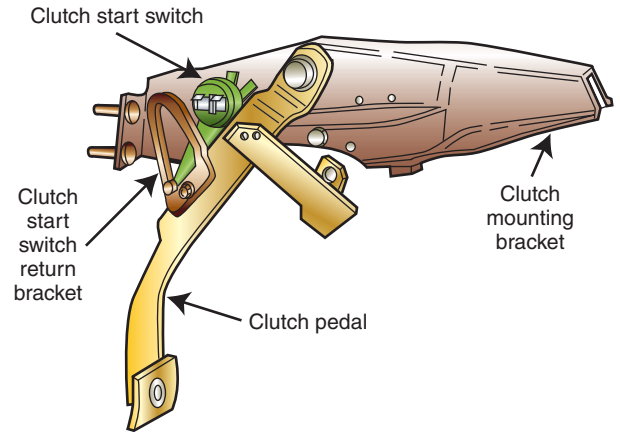
Many vehicles equipped with manual transmissions use a similar type of safety switch. The **startclutch interlock switch** is usually operated by movement of the clutch pedal (Figure 6-37). When the clutch pedal is pushed downward, the switch closes and current can flow through the starter circuit. If the clutch pedal is left up, the switch is open and current cannot flow.

Some vehicles use a mechanical linkage that blocks movement of the ignition switch cylinder unless the transmission is in PARK or NEUTRAL (Figure 6-38).

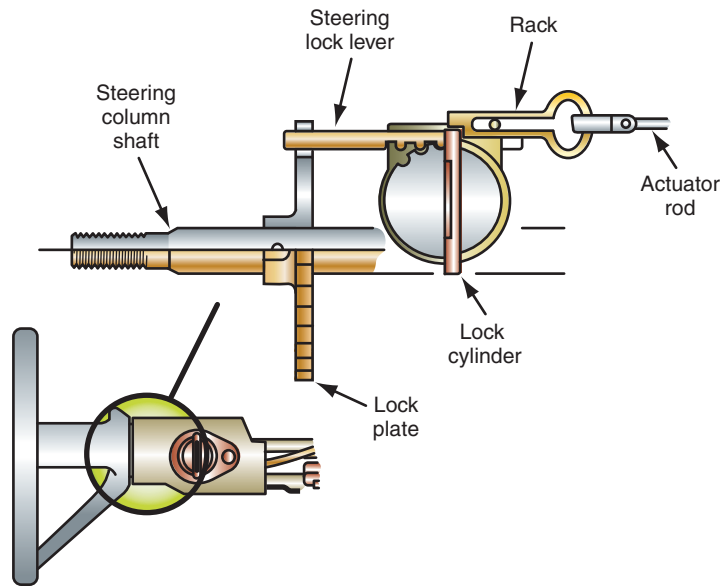
**AUTHOR'S NOTE:** One-touch and remote starting systems will be discussed in Chapter 14.



**FIGURE 6-36** The neutral safety switch can be combined with the backup light switch and installed on the transmission case.



**FIGURE 6-37** Most vehicles with a manual transmission use a clutch start switch to prevent the engine from starting unless the clutch pedal is pressed.



**FIGURE 6-38** Mechanical linkage used to prevent starting the engine while the transmission is in gear.

### Shop Manual

Chapter 6, page 247

## CRANKING MOTOR DESIGNS

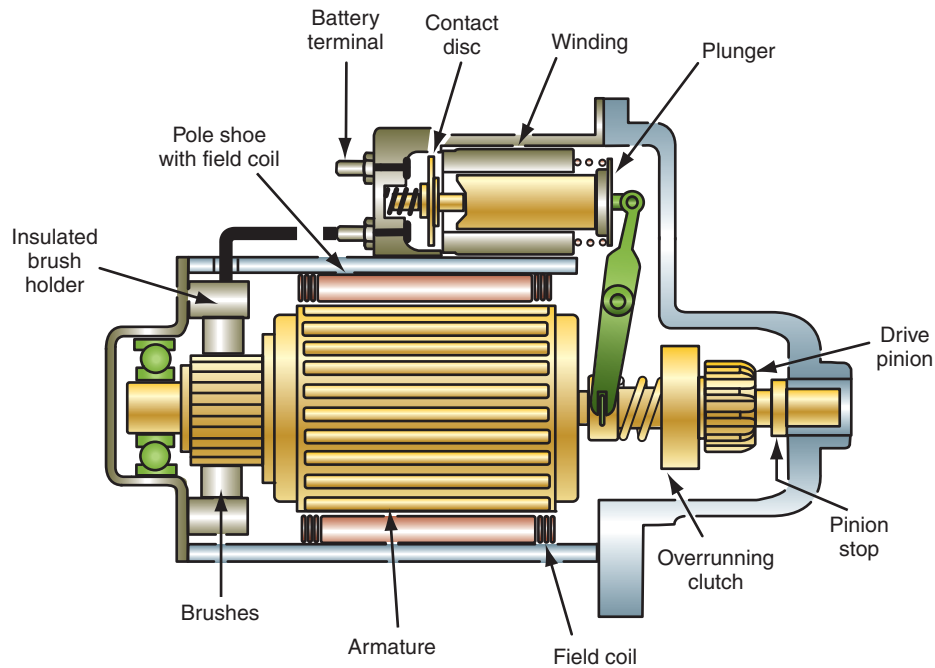
The most common type of starter motor used today incorporates the overrunning clutch starter drive instead of the old inertia-engagement bendix drive. There are four basic groups of starter motors:

1. Direct drive.
2. Gear reduction.
3. Positive-engagement (moveable pole).
4. Permanent magnet.

The direct drive starter motor can be either series-wound or compound motors.

### Direct Drive Starters

A common type of starter motor is the solenoid-operated direct drive unit (Figure 6-39). Although there are construction differences between applications, the operating principles are the same for all solenoid-shifted starter motors.



**FIGURE 6-39** Solenoid operated Delco MT series starter motor.

© Delmar/Cengage Learning

When the ignition switch is placed in the START position, the control circuit energizes the pull-in and hold-in windings of the solenoid. The solenoid plunger moves and pivots the shift lever, which in turn locates the drive pinion gear into mesh with the engine flywheel.

When the solenoid plunger is moved all the way, the contact disc closes the circuit from the battery to the starter motor. Current now flows through the field coils and the armature. This develops the magnetic fields that cause the armature to rotate, thus turning the engine.

## Gear Reduction Starters

Some manufacturers use a gear reduction starter to provide increased torque (Figure 6-40). The gear reduction starter differs from most other designs in that the armature does not drive the pinion gear directly. In this design, the armature drives a small gear that is in constant mesh with a larger gear. Depending on the application, the ratio between these two gears is between 2:1 and 3.5:1. The additional reduction allows for a small motor to turn at higher speeds and greater torque with less current draw.

The solenoid operation is similar to that of the solenoid-shifted direct drive starter in that the solenoid moves the plunger, which engages the starter drive.

## Positive-Engagement Starters

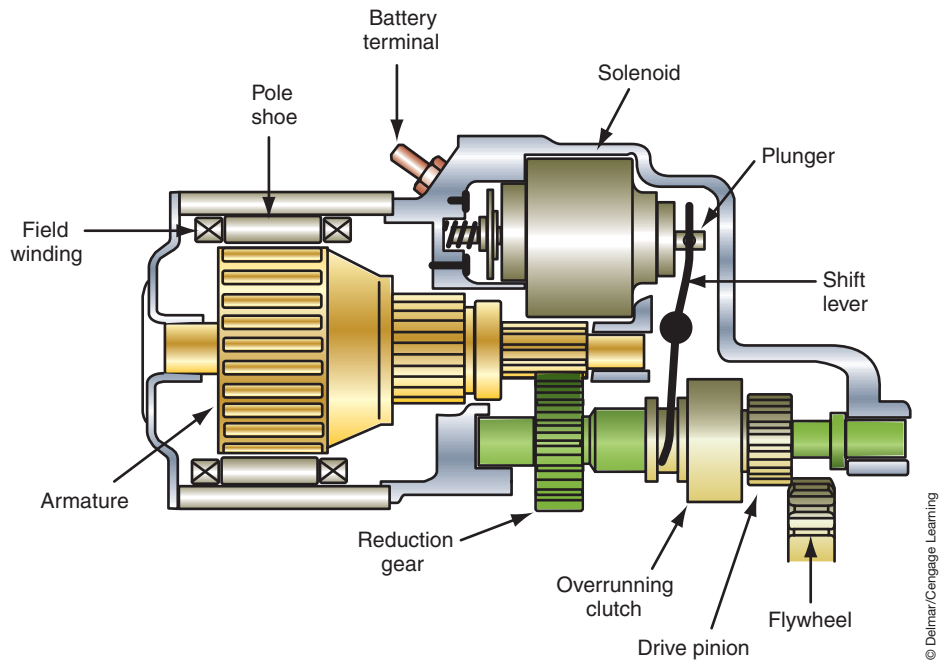
A commonly used starter on Ford applications in the past was the positive-engagement starter (Figure 6-41). Positive-engagement starters use the shunt coil windings of the starter motor to engage the starter drive. The high starting current is controlled by a starter solenoid mounted close to the battery. When the solenoid contacts are closed, current flows through a drive coil. The drive coil creates an electromagnetic field that attracts a moveable pole shoe. The moveable pole shoe is attached to the starter drive through the plunger lever. When the moveable pole shoe moves, the drive gear engages the engine flywheel.

As soon as the starter drive pinion gear contacts the ring gear, a contact arm on the pole shoe opens a set of normally closed grounding contacts (Figure 6-42). With the return to ground circuit opened, all the starter current flows through the remaining three field coils

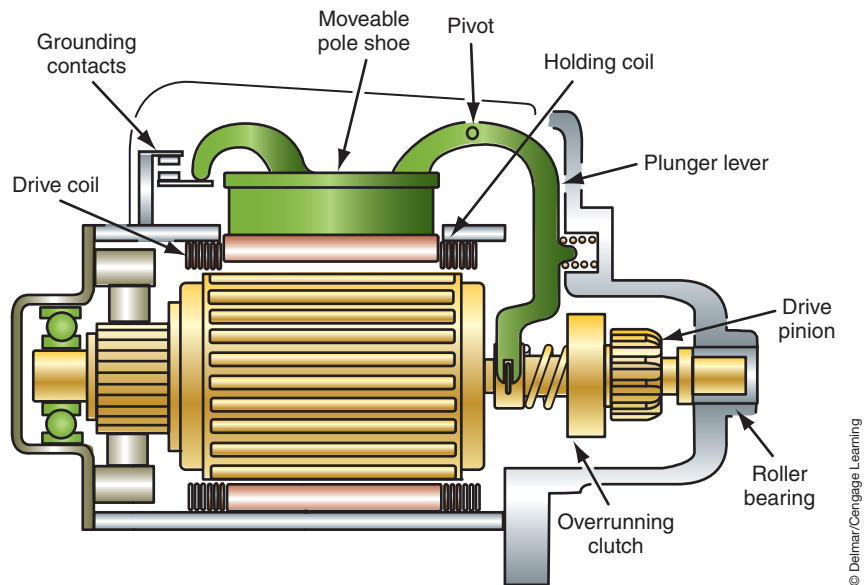
Some gear reduction starter motors are compound motors.

Most gear reduction starters have the commutator and brushes located in the center of the motor.

Positive-engagement starters are also called moveable-pole shoe starters.



**FIGURE 6-40** Gear reduction starter motor construction.



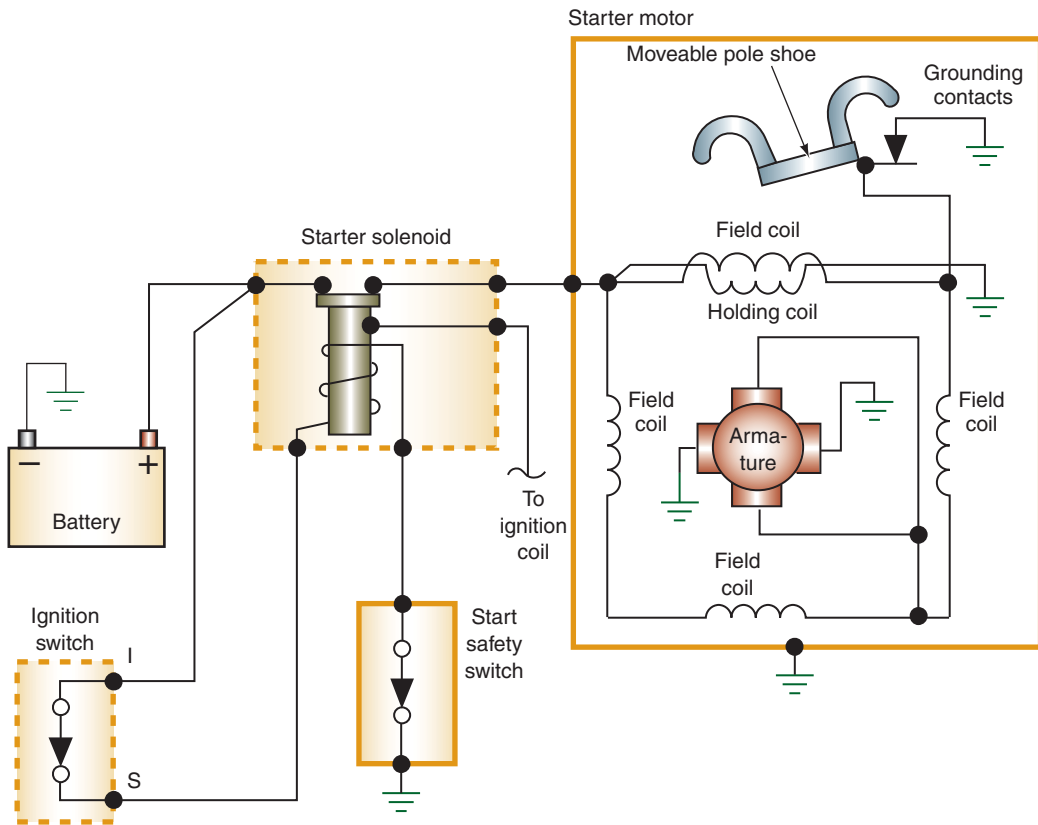
**FIGURE 6-41** Positive engagement starters use a moveable pole shoe.

The **drive coil** is a hollowed field coil that is used to attract the moveable pole shoe.

and through the brushes to the armature. The starter motor then begins to rotate. To prevent the starter drive from disengaging from the ring gear if battery voltage drops while cranking, the moveable pole shoe is held down by a holding coil. The holding coil is a smaller coil inside the main **drive coil** and is strong enough to hold the starter pinion gear engaged.

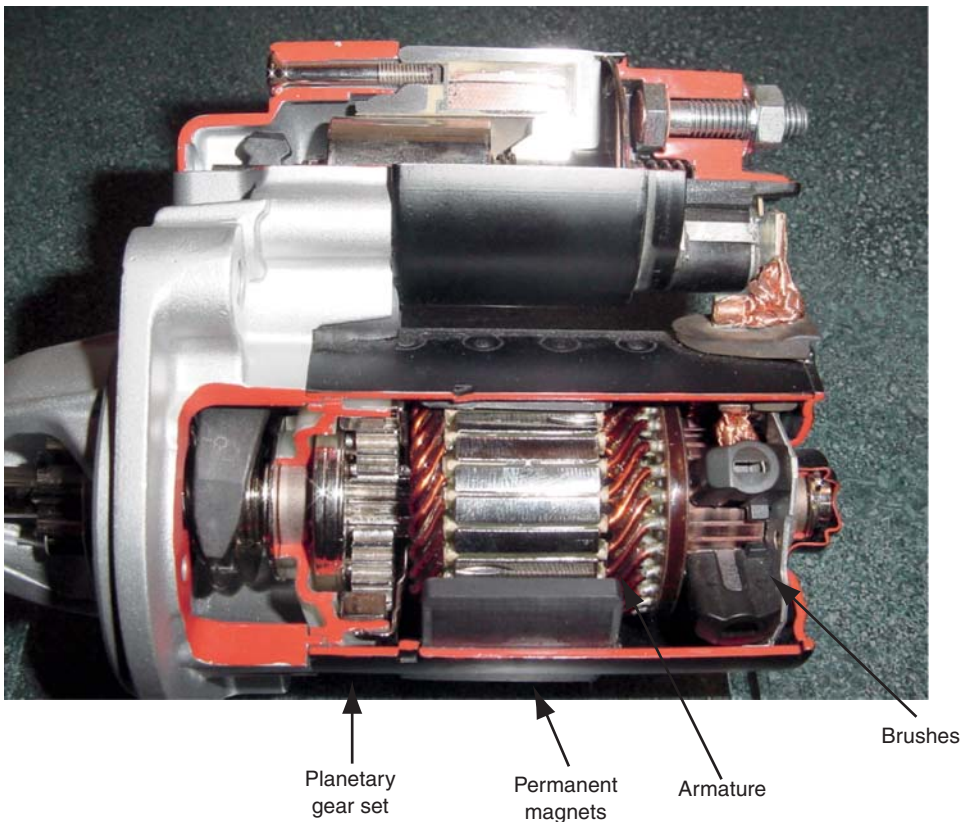
## Permanent Magnet Starters

The **permanent magnet gear reduction (PMGR)** starter design provides for less weight, simpler construction, and less heat generation as compared to conventional field coil starters (Figure 6-43). The permanent magnet gear reduction starter uses four or six permanent magnet field assemblies in place of field coils. Because there are no field coils, current is delivered directly to the armature through the commutator and brushes.



**FIGURE 6-42** Schematic of positive-engagement starter.

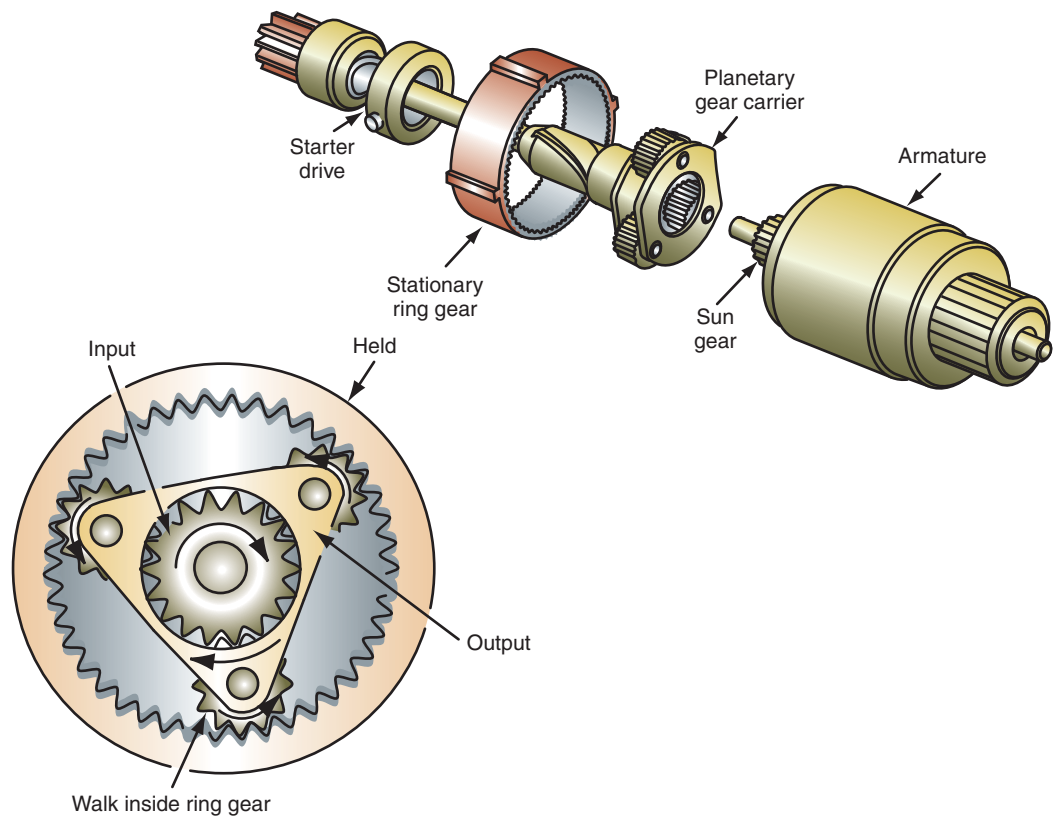
© Delmar/Cengage Learning



**FIGURE 6-43** The PMGR motor uses a planetary gear set and permanent magnets.

© Delmar/Cengage Learning





**FIGURE 6-44** Planetary gear set.

© Delmar/Cengage Learning

The permanent magnet starter also uses gear reduction through a planetary gear set (Figure 6-44). The planetary geartrain transmits power between the armature and the pinion shaft. This allows the armature to rotate at greater speed and increased torque. The planetary gear assembly consists of a sun gear on the end of the armature and three planetary carrier gears inside a ring gear. The ring gear is held stationary. When the armature is rotated, the sun gear causes the carrier gears to rotate about the internal teeth of the ring gear. The planetary carrier is attached to the output shaft. The gear reduction provided for by this gear arrangement is 4.5:1. By providing for this additional gear reduction, the demand for high current is lessened.

**AUTHOR'S NOTE:** The greatest amount of gear reduction from a planetary gear set is accomplished by holding the ring gear, inputting the sun gear, and outputting the carrier.

The electrical operation between the conventional field coil and PMGR starters remains basically the same (Figure 6-45).

## AC MOTOR PRINCIPLES

A few years ago, the automotive technician did not need to be concerned much about the operating principles of the AC motor. With the increased focus on HEVs and EVs, this is no longer an option since most of these vehicles use AC motors (Figure 6-46).

As discussed in Chapter 2, AC voltage has a changing direction of current flow. However, this change does not occur immediately (Figure 6-47). Notice that the AC voltage sine wave indicates that in one cycle the voltage will be zero at three times. Also notice that as the current changes directions, it gradually builds up or falls in the other direction. The sine wave illustrates that the amount of current in an AC circuit always varies. The current rating is based on the average referred to as a root mean square (RMS) value.

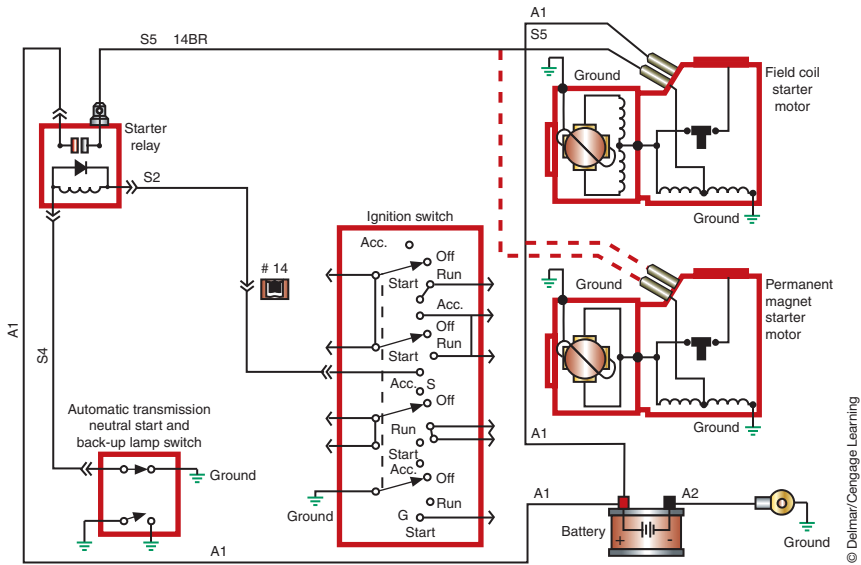


FIGURE 6-45 Comparison of the electrical circuits used in field coil and PMGR starters.



FIGURE 6-46 AC three-phase motor used in a HEV.

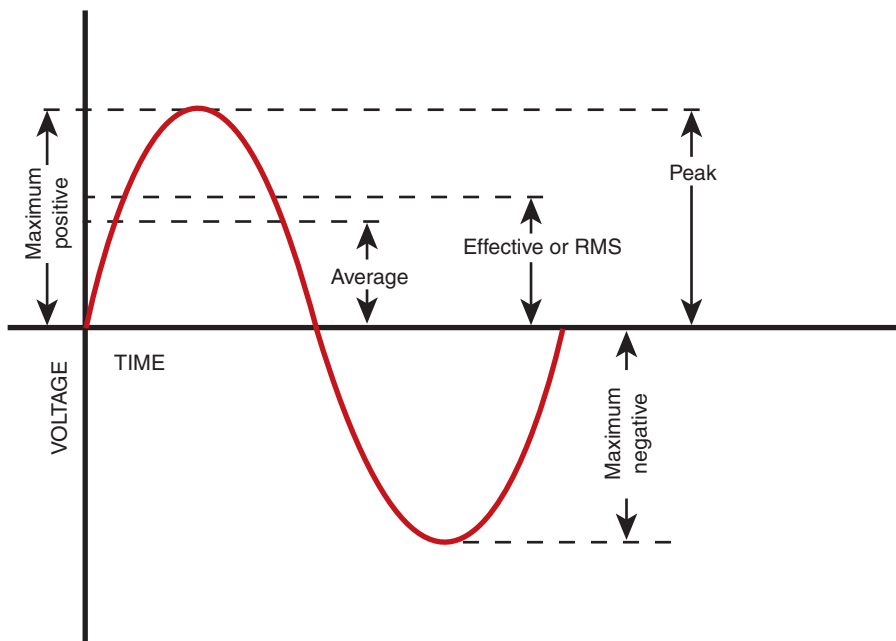


FIGURE 6-47 AC voltage gradually changes. It is rated at the RMS.

## AC Motor Construction

A **synchronous motor** operates at a constant speed regardless of load. An **induction motor** generates its own rotor current as the rotor cuts through the magnetic flux lines of the stator field.

Like the DC motor, the AC motor uses a stator (field winding) and a rotor. Common types of AC motors are the **synchronous motor** and the **induction motor**. In both motor types, the stator comprises individual electromagnets that are either electrically connected to each other or connected in groups. The difference is in the rotor designs. AC motors can use either single-phase or three-phase AC current. Since the three-phase is the most common motor used in HEV and EV vehicles, we will focus our discussion on these.

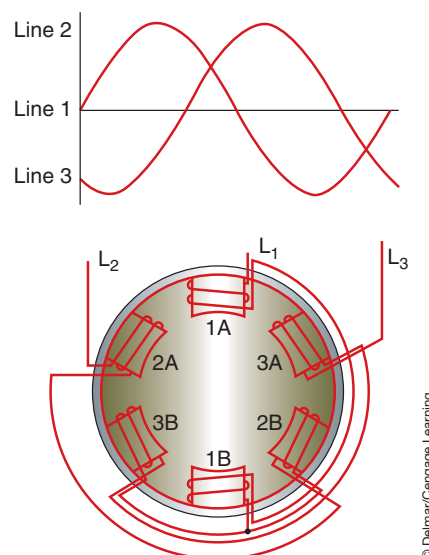
**AUTHOR'S NOTE: Three-phase AC voltage is commonly used in motors because it provides a smoother and more constant supply of power. Three-phase AC voltage is like having three independent AC power sources, which have the same amplitude and frequency but are 120 degrees out of phase with each other.**

As in a DC motor, the movement of the rotor is the result of the repulsion and attraction of the magnetic poles. However, the way this works in an AC motor is very different. Because the current is alternating, the polarity in the windings constantly changes. The principle of operation for all three-phase motors is the **rotating magnetic field**. The rotor turns because it is pulled along by a rotating magnetic field in the stator. The stator is stationary and does not physically move. However, the magnetic field does move from pole to pole. There are three factors that cause the magnetic field to rotate (Figure 6-48). The first is the fact that the voltages in a three-phase system are 120 degree out of phase with each other. The second is the fact that the three voltages change polarity at regular intervals. Finally, the third factor is the arrangement of the stator windings around the inside of the motor.

In Figure 6-48 the stator is a two-pole three-phase motor. Two-pole means that there are two poles per phase. The motor is wired with three leads:  $L_1$ ,  $L_2$ , and  $L_3$ .

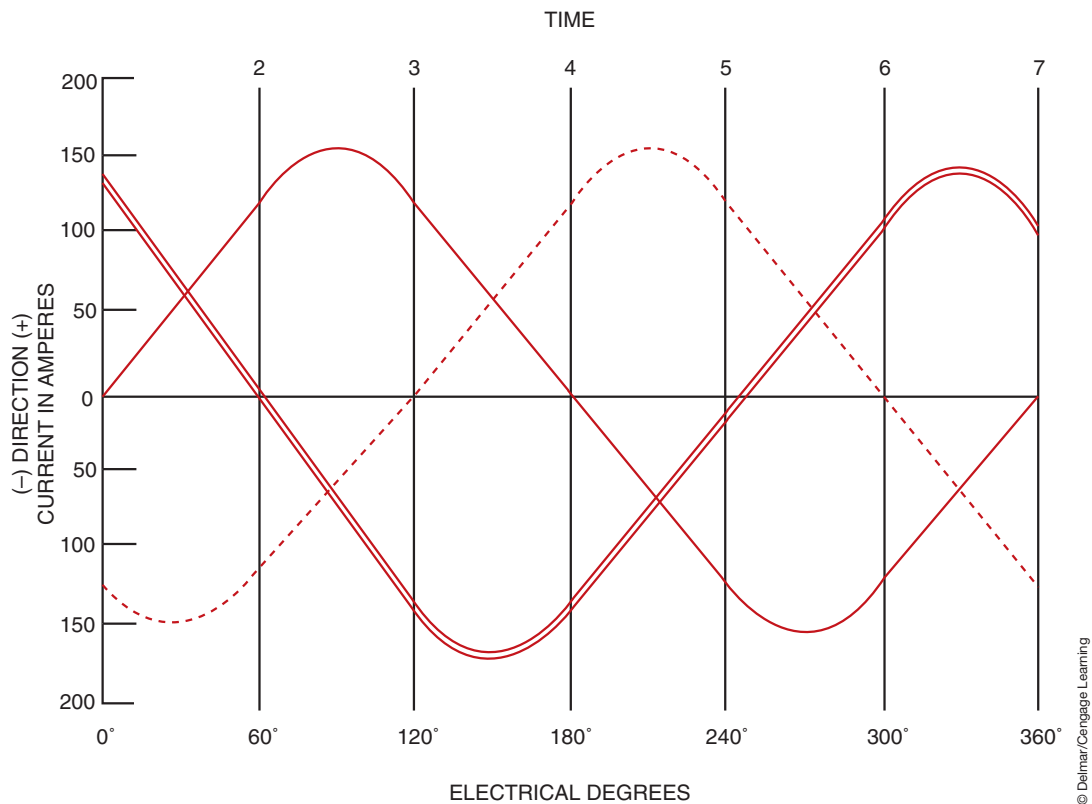
**AUTHOR'S NOTE: The stator of AC motors do not have actual pole pieces as shown in Figure 6-48. They are illustrated to help understand how the rotating magnetic field is created in a three-phase motor.**

Each of the poles is wound in such a manner that when current flows through the winding they develop opposite magnetic polarities. All three windings are joined to form a wye connection for the stator. Since each phase reaches its peak at successively later times



© Delmar/Cengage Learning

**FIGURE 6-48** The motor stator is energized with the three-phase AC voltage.



**FIGURE 6-49** The three AC sine waves are 120° apart. At any one time there are two voltages at the same polarity.

(Figure 6-49), the strongest point of the magnetic field in each winding is also in succession. This succession of the magnetic fields is what creates the effect of the magnetic field continually moving around the stator.

Since the rotating magnetic field will rotate around the stator once for every cycle of the voltage in each phase, the field is rotating at the frequency of the source voltage. Remember that as the magnetic field moves, new magnetic polarities are present. As each polarity change is made, the poles of the rotor are attracted by the opposite poles on the stator. Therefore, as the magnetic field of the stator rotates, the rotor rotates with it. The speed with which the rotor turns depends on the number of windings and poles built into the motor, the frequency of the AC supply voltage, and the load on the rotor's shaft. Frequency modulation (thus motor speed) can be altered by use of controllers.

## Synchronous Motors

The speed at which the magnetic field rotates is called the **synchronous speed**. The two main factors determining the synchronous speed of the rotating magnetic field are the number of stator poles (per phase) and the frequency of the applied voltage. A synchronous motor operates at a constant speed, regardless of load. The speed of the rotor is equal to the synchronous speed.

The synchronous motor does not depend on induced current in the rotor to produce torque. The strength of the magnetic field determines the torque output of the rotor, while the speed of the rotor is determined by the frequency of the AC input to the stator.

Synchronous motors cannot be started by the applying of three-phase AC power to the stator. This is because when the AC voltage is applied to the stator windings, a high-speed rotating magnetic field is present immediately. The rotating magnetic field will pass the rotor so quickly that the rotor does not have time to start turning.

In order to start the motor, the rotor contains a squirrel-type winding made of heavy copper bars connected by copper rings. When voltage is first applied to the stator windings, the resulting rotating magnetic field cuts through the squirrel-cage bars. The cutting action of the field induces

The squirrel-cage is known as the **amortisseur winding**.

The induction motor is also referred to as an asynchronous motor.

a current into the squirrel-cage. Since the squirrel cage is shorted, the low voltage that is induced into the squirrel-cage windings results in a relatively large current flow in the cage. This current flow produces a magnetic field within the rotor that is attracted to the rotating magnetic field of the stator. The result is the rotor begins to turn in the direction of rotation of the stator field.

The construction the rotor of a synchronous motor includes wound pole pieces that become electromagnets when DC voltage is applied to them. The excitation current can be applied to the rotor through sliprings or by a brushless exciter. As the rotor is accelerated to a speed of 95% of the speed of the rotating magnetic field, DC voltage is connected to the rotor through the sliprings on the rotor shaft or by a brushless exciter. The application of DC voltage to the rotor windings results in the creation of electromagnets. The electromagnetic field of the rotor is locked in step with the rotating magnetic field of the stator. The rotor will now turn at the same speed as the rotating magnetic field. Since the rotor is turning at the synchronous speed of the field, the cutting action between the stator field and the winding of the squirrel cage has ceased. This stops the induction of current flow in the squirrel cage. The speed of the rotor is locked to the speed of the rotating magnetic field even as different loads are applied.

## Induction Motors

An induction motor generates its own rotor current by induced voltage from the rotating magnetic field of the stator. The current is induced in the windings of the rotor as it cuts through the magnetic flux lines of the rotating stator field (Figure 6-50). Generally, the rotor windings are in the form of a squirrel cage. However, wound-rotor motors are constructed by winding three separate coils on the rotor 120 degree apart. The rotor will contain as many poles per phase as the stator winding. These coils are connected to three sliprings located on the rotor shaft so brushes can provide an external connection to the rotor.

When voltage is first applied to the stator windings, the rotor is not turning. To start the squirrel cage induction motor, the magnetic field of the stator cuts the rotor bars that induce a voltage into the cage bars. This induced voltage is the same frequency as the voltage applied to the stator. Since the rotor is stationary, maximum voltage is induced into the squirrel cage and causes current to flow through the cage's bars. The current flow results in the production of a magnetic field around each bar.

The magnetic field of the rotor is attracted to the rotating magnetic field of the stator. The rotor begins to turn in the same direction as the rotating magnetic field. As the rotor increases in speed, the rotating magnetic field cuts the cage bars at a slower rate, resulting in less voltage being induced into the rotor. This also results in a reduction of rotor current. With the decrease in rotor current, the stator current also decreases. If the motor is operating without a load, the rotor continues to accelerate until it reaches a speed close to that of the rotating magnetic field. This means that when a squirrel-cage induction motor is first started, it has a current draw several times greater than its normal running current.

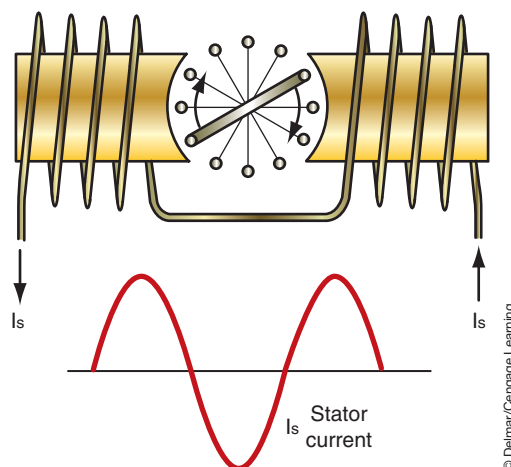


FIGURE 6-50 Concept of the induction motor.



© Delmar/Cengage Learning

**FIGURE 6-51** The inverter module controls the speed and direction of the AC motor.

If the rotor were to turn at the same speed as the rotating magnetic field, there would be no induced voltage in the rotor and, consequently, no rotor current. This means that an induction motor can never reach synchronous speed. If the motor is operated with no load, the rotor will accelerate until the torque developed is proportional to friction losses. As loads are applied to the motor, additional torque is required to overcome the load. The increase in load causes a reduction in rotor speed. This results in the rotating magnetic field cutting the cage bars at a faster rate. This in turn increases the induced voltage and current in the cage and produces a stronger magnetic field in the rotor, thus, more torque to be produced. The increased current flow in the rotor causes increased current flow in the stator. This is why motor current increases as load is added.

The difference between the synchronous speed and actual rotor speed is called **slip**. Slip is directly proportional to the load on the motor. When loads are on the rotor's shaft, the rotor tends to slow and slip increases. The slip then induces more current in the rotor and the rotor turns with more torque, but at a slower speed and therefore produces less CEMF.

In HEVs and EVs, the direction of motor rotation will need to change to meet certain operating requirements. In a three-phase AC motor, the direction of rotation can be changed by simply reversing any two of its stator leads. This causes the direction of the rotating magnetic field to reverse.

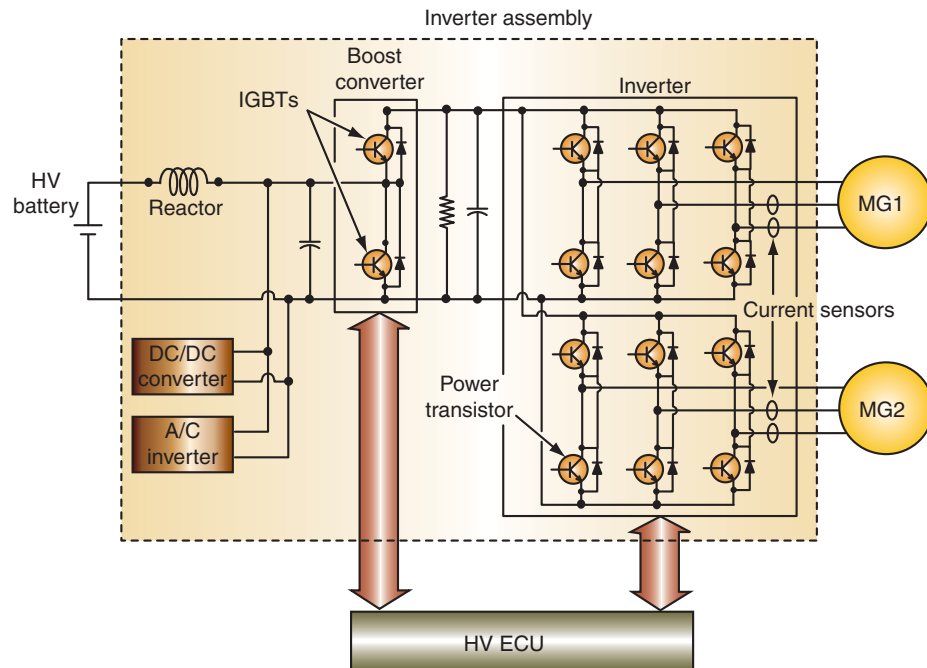
An electronic controller is used to manage the flow of electricity from the HV battery pack to control the speed and direction of rotation of the electric motor(s). The intent of the driver is relayed to the controller by use of an accelerator position sensor. The controller monitors this signal plus other inputs regarding the operating conditions of the vehicle. Based on this inputs, the controller provides a duty cycle control of the voltage levels to the motor(s).

If the HEV or EV uses AC motors, an inverter module is used to convert the DC voltage from the HV battery to a three-phase AC voltage for the motor (Figure 6-51). This conversion is done by using sets of power transistors. The transistors PWM the voltage while reversing polarity at a fixed frequency (Figure 6-52). The inverter module is usually a slave module to the hybrid control processor. Often the inverter module is called the motor control processor since it not only provides for current modification but also motor control.

## INTEGRATED STARTER GENERATOR

One of the newest technologies to emerge is the **integrated starter generator (ISG)**. Although this system can be used in conventional engine-powered vehicles, one of the key contributors to the Hybrid's fuel efficiency is its ability to automatically stop and restart the engine under different operating conditions. A typical Hybrid vehicle uses a 14 kilowatt (kW) electric induction motor or ISG between the engine and the transmission. The ISG performs many functions such as fast, quiet starting, automatic engine stops/starts to conserve fuel, recharges the vehicle batteries, smoothes driveline surges, and provide regenerative braking.





**FIGURE 6-52** Boost and power transistors of the inverter module.

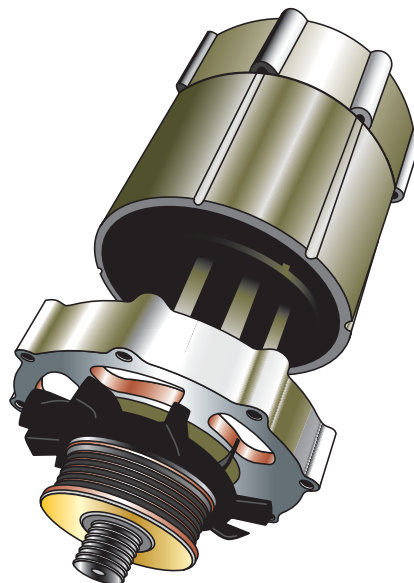
© Delmar/Cengage Learning

The ISG is a three-phase AC motor. At low vehicle speeds, the ISG provides power and torque to the vehicle. It also supports the engine, when the driver demands more power. During vehicle deceleration, ISG regenerates the power that is used to charge the traction batteries.

The ISG can also convert kinetic energy from AC to DC voltage. When the vehicle is traveling downhill and there is zero load on the engine, the wheels can transfer energy through the transmission and engine to the ISG. The ISG then sends this energy to the HV battery for storage.

An ISG can be mounted externally to the engine and connected to the crankshaft with a drive belt (Figure 6-53). This design is called a **belt alternator starter (BAS)**. In these applications, the unit can function as the engine's starter motor as well as a generator driven by the engine.

Both the BAS and the ISG use the same principle to start the engine. Current flows through the stator windings it generates magnetic fields in the rotor. This will cause the rotor to turn, thus turning the crankshaft and starting the engine. In addition, this same principle is used to assist the engine as needed when the engine is running.



**FIGURE 6-53** A BAS mounted external to the engine.

© Delmar/Cengage Learning

## SUMMARY

---

- The starting system is a combination of mechanical and electrical parts that work together to start the engine.
- The starting system components include the battery, cable and wires, the ignition switch, the starter solenoid or relay, the starter motor, the starter drive and flywheel ring gear, and the starting safety switch.
- The armature is the moveable component of the motor that consists of a conductor wound around a laminated iron core. It is used to create a magnetic field.
- Pole shoes are made of high-magnetic permeability material to help concentrate and direct the lines of force in the field assembly.
- The magnetic forces will cause the armature to turn in the direction of the weaker field.
- Within an electromagnetic style of starter motor, the inside windings are called the armature. The armature rotates within the stationary outside windings, called the field, which has windings coiled around pole shoes.
- The commutator is a series of conducting segments located around one end of the armature.
- A split-ring commutator is in contact with the ends of the armature loops. So, as the brushes pass over one section of the commutator to another, the current flow in the armature is reversed.
- Two basic winding patterns are used in the armature: lap winding and wave winding.
- The field coils are electromagnets constructed of wire coils wound around a pole shoe.
- When current flows through the field coils, strong stationary electromagnetic fields are created.
- In any DC motor, there are three methods of connecting the field coils to the armature: in series, in parallel (shunt), and a compound connection that uses both series and shunt coils.
- A starter drive includes a pinion gear set that meshes with the engine flywheel ring gear on the engine.
- To prevent damage to the pinion gear or the ring gear, the pinion gear must mesh with the ring gear before the starter motor rotates.
- The bendix drive depends on inertia to provide meshing of the drive pinion with the ring gear.
- The most common type of starter drive is the overrunning clutch. This is a roller-type clutch that transmits torque in one direction only and freewheels in the other direction.
- The starting system consists of two circuits called the starter control circuit and the motor feed circuit.
- The components of the control circuit include the starting portion of the ignition switch, the starting safety switch (if applicable), and the wire conductor to connect these components to the relay or solenoid.
- The motor feed circuit consists of heavy battery cables from the battery to the relay and the starter or directly to the solenoid if the starter is so equipped.
- There are four basic groups of starter motors: direct drive, gear reduction, positive engagement (moveable pole), and permanent magnet.
- A synchronous motor operates at a constant speed regardless of load.
- An induction motor generates its own rotor current as the rotor cuts through the magnetic flux lines of the stator field.
- The principle of operation for all three-phase motors is the rotating magnetic field.

## TERMS TO KNOW

Amortisseur winding  
Armature  
Belt alternator starter (BAS)  
Brushes  
Commutator  
Compound motor  
Counter electromotive force (CEMF)  
Double-start override  
Drive coil  
Eddy currents  
Field coils  
Hold-in windings  
Induction motor  
Integrated starter generator (ISG)  
Laminated construction  
Overrunning clutch  
Permanent magnet gear reduction (PMGR)  
Pole shoes  
Pull-in windings  
Ratio

## SUMMARY

### TERMS TO KNOW

(continued)

Rotating magnetic field

Sentry key

Shunt

Slip

Start/clutch interlock switch

Starter drive

Static neutral point

Synchronous motor

Synchronous speed

- In order to start the synchronous motor, the rotor contains a squirrel-type winding to act as an induction motor.
- An induction motor rotor windings can be in the form of a squirrel cage or constructed by winding three separate coils on the rotor 120° apart.
- The ISG can also convert kinetic energy to storable electric energy. When the vehicle is traveling downhill and there is zero load on the engine, the wheels can transfer energy through the transmission and engine to the ISG. The ISG then sends this energy to the battery for storage and use by the electrical components of the vehicle.
- The belt alternator starter (BAS) is about the same size as a conventional generator and is mounted in the same way.
- The IGS is a three-phase AC motor. At low vehicle speeds, the ISG provides power and torque to the vehicle. It also supports the engine, when the driver demands more power.
- Both the BAS and the ISG use the same principle to start the engine. Current flows through the stator windings it generates magnetic fields in the rotor. This will cause the rotor to turn, thus turning the crankshaft and starting the engine.

## REVIEW QUESTIONS

### Short-Answer Essays

1. What is the purpose of the starting system?
2. List and describe the purpose of the major components of the starting system.
3. Explain the principle of operation of the DC motor.
4. Describe the types of magnetic switches used in starting systems.
5. Describe the operation of the overrunning clutch drive.
6. Describe the differences between the positive-engagement and solenoid shift starter.
7. Explain the operating principles of the permanent magnet starter.
8. Describe the purpose and operation of the armature.
9. Describe the purpose and operation of the field coil.
10. Describe how the rotor turns in a three-phase AC motor

### Fill in the Blanks

1. DC motors use the interaction of magnetic fields to convert the \_\_\_\_\_ energy into \_\_\_\_\_ energy.
2. The \_\_\_\_\_ is the moveable component of the motor, which consists of a conductor wound around a \_\_\_\_\_ iron core and is used to create a \_\_\_\_\_ field.

3. Pole shoes are made of high-magnetic \_\_\_\_\_ material to help concentrate and direct the \_\_\_\_\_ in the field assembly.
4. The starter motor electrical connection that permits all of the current that passes through the field coils to also pass through the armature is called the \_\_\_\_\_ motor.
5. \_\_\_\_\_ is voltage produced in the starter motor itself. This current acts against the supply voltage from the battery.
6. A starter motor that uses the characteristics of a series motor and a shunt motor is called a \_\_\_\_\_ motor.
7. The \_\_\_\_\_ is the part of the starter motor that engages the armature to the engine flywheel ring gear.
8. The \_\_\_\_\_ is a roller-type clutch that transmits torque in one direction only and freewheels in the other direction.
9. The two circuits of the starting system are called the \_\_\_\_\_ circuit and the \_\_\_\_\_ circuit.
10. There are two basic types of magnetic switches used in starter systems: the \_\_\_\_\_ and the \_\_\_\_\_.

## MULTIPLE CHOICE

- The armature:
  - Is the stationary component of the starter that creates a magnetic field.
  - Is the rotating component of the starter that creates a magnetic field.
  - Carries electrical current to the commutator.
  - Prevents the starter from engaging if the transmission is in gear.
- What is the purpose of the commutator?
  - To prevent the field windings from contacting the armature.
  - To maintain constant electrical contact with the field windings.
  - To reverse current flow through the armature.
  - All of the above.
- The field coils:
  - Are made of wire wound around a nonmagnetic pole shoe.
  - Are always shunt wound to the armature.
  - Are always series wound with the armature.
  - None of the above.
- Which of the following describes the operation of the starter solenoid?
  - An electromagnetic device that uses movement of a plunger to exert a pulling or holding force.
  - Both the pull-in and hold-in windings are energized to engage the starter drive.
  - When the starter drive plunger is moved, the pull-in winding is de-energized.
  - All of the above.
- In the ISG, how does current flow to make the system perform as a starter?
  - Through the rotor to create an electromagnetic field that excites the stator, which causes the rotor to spin.
  - Through the rotor coils, which cause the magnetic field to collapse around the stator and rotate the crankshaft.
  - Through the stator windings, which generate magnetic fields in the rotor, causing the rotor to turn the crankshaft.
  - From the start generator control module to the rotor coils that are connected to the delta wound stator.
- Permanent magnet starters are being discussed. *Technician A* says the permanent magnet starter uses four or six permanent magnet field assemblies in place of field coils. *t* says the permanent magnet starter uses a planetary gear set. Who is correct?
  - A only
  - B only
  - Both A and B
  - Neither A nor B
- Typical components of the control circuit of the starting system include:
  - Ring gear.
  - Magnetic switch.
  - Pinion gear.
  - All of the above.
- The characteristic of the series-wound motor is:
  - Current flows from the armature, to the brushes, then to the field windings.
  - Current flows from the field windings, to the brushes, and to the armature.
  - Current flows through shunts to the field windings and the armature.
  - All of the above.
- The gear reduction starter uses:
  - A starter drive that is connected directly to the armature.
  - A larger gear to drive a smaller gear that is attached to the starter drive.
  - A smaller gear to drive a larger gear that is attached to the starter drive.
  - A starter drive that is attached to the commutator ring.
- A characteristic of permanent magnet starters is:
  - The use of planetary gears.
  - Current flows from the field windings, to the brushes, and to the armature.
  - Connection directly to the armature.
  - All of the above.

## CHARGING SYSTEMS

### UPON COMPLETION AND REVIEW OF THIS CHAPTER, YOU SHOULD BE ABLE TO UNDERSTAND AND DESCRIBE:

- The purpose of the charging system.
- The major components of the charging system.
- The function of the major components of the AC generator.
- The two styles of stators.
- How AC current is rectified to DC current in the AC generator.
- The three principle circuits used in the AC generator.
- The relationship between regulator resistance and field current.
- The relationship between field current and AC generator output.
- The differences between A circuit, B circuit, and isolated circuit.
- The operation of charge indicators, including lamps, electronic voltage monitors, ammeters, and voltmeters.
- The use of the ISG and AC motors in an HEV to recharge the HV battery.
- How regenerative braking is used to recharge the HV battery.
- The purpose of the DC/DC converter for charging the HEV auxiliary battery.

### INTRODUCTION

The automotive storage battery is not capable of supplying the demands of the electrical system for an extended period of time. Every vehicle must be equipped with a means of replacing the current being drawn from the battery. A charging system is used to restore the electrical power to the battery that was used during engine starting. In addition, the charging system must be able to react quickly to high load demands required of the electrical system. It is the vehicle's charging system that generates the current to operate all of the electrical accessories while the engine is running.

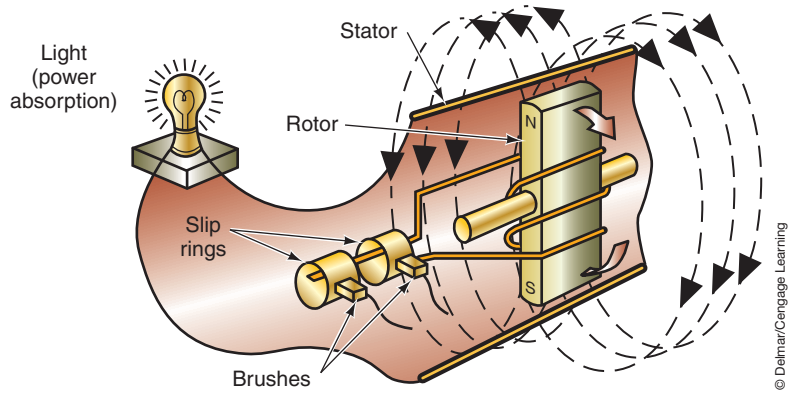
Two basic types of charging systems have been used. The first was a DC generator, which was discontinued in the 1960s. Since that time the AC generator has been the predominant charging device. The DC generator and the AC generator both use similar operating principles.

The purpose of the conventional charging system is to convert the mechanical energy of the engine into electrical energy to recharge the battery and run the electrical accessories. When the engine is first started, the battery supplies all the current required by the starting and ignition systems.

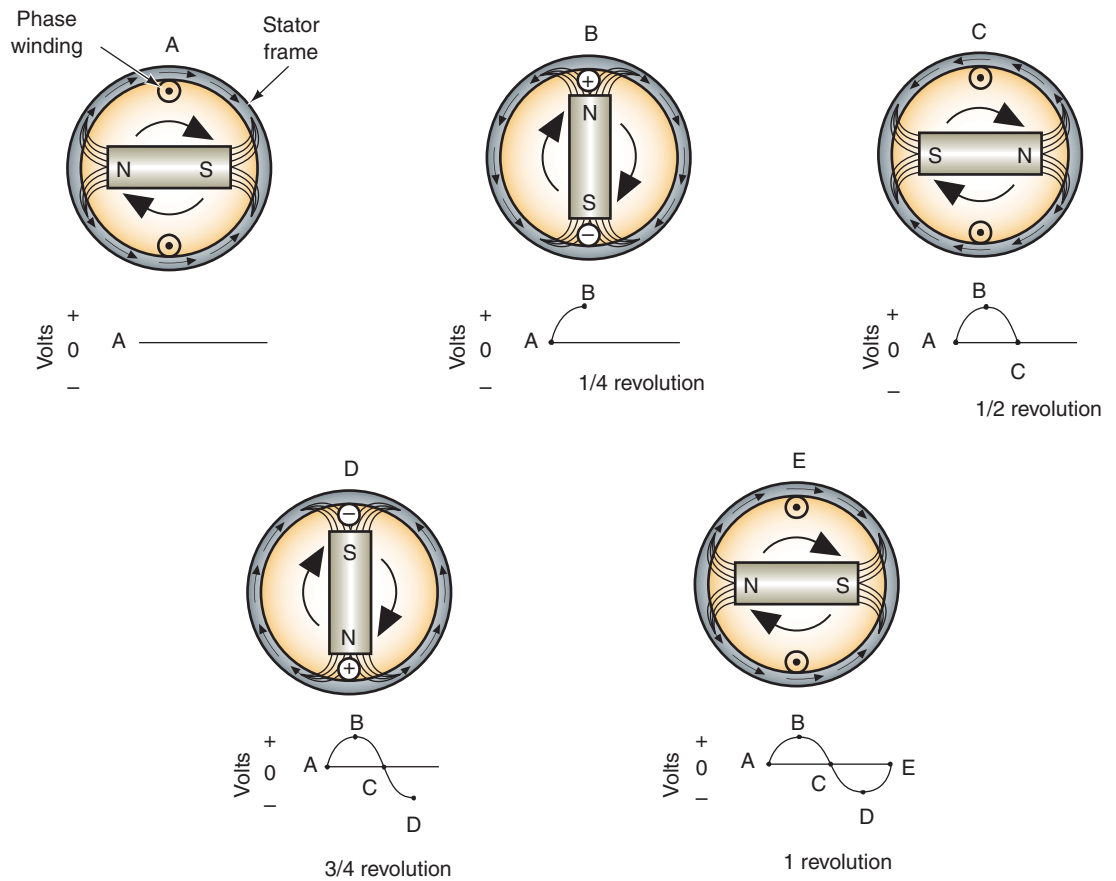
In an attempt to standardize terminology in the industry, the term *alternator* is being replaced with *generator*. Often an alternator is referred to as an AC generator.







**FIGURE 7-2** Simplified AC generator indicating electromagnetic induction.



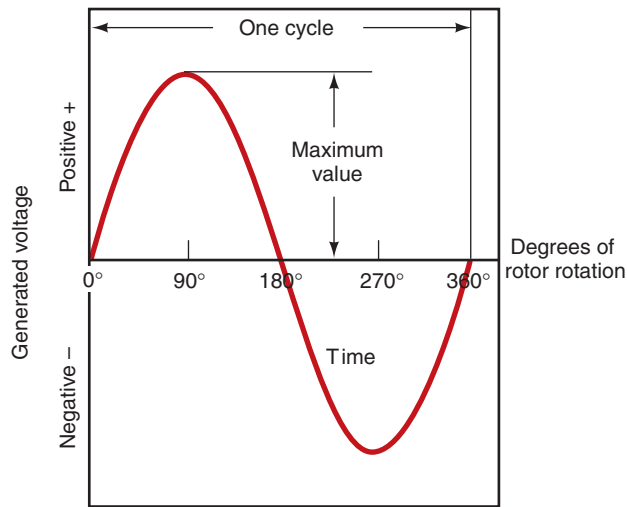
**FIGURE 7-3** Alternating current is produced as the magnetic field is rotated.

The sine wave produced by a single conductor during one revolution is called single-phase voltage.

parallel with the magnetic field, the conductor is not cut by any flux lines (Figure 7-3A). At this point in the revolution, zero voltage and current are being produced.

As the magnetic field is rotated 90 degrees, the magnetic field is at a right angle to the conductor (Figure 7-3B). At this point in the revolution, the maximum number of flux lines cut the conductor at the north pole. With the maximum amount of flux lines cutting the conductor, voltage is at its maximum positive value.

When the magnetic field is rotated an additional 90 degrees, the conductor returns to being parallel with the magnetic field (Figure 7-3C). Once again, no flux lines cut the conductor and voltage drops to zero.



© Delmar/Cengage Learning

**FIGURE 7-4** Sine wave produced in one revolution of the conductor or magnetic field.

An additional 90-degree revolution of the magnetic field results in the magnetic field being reversed at the top conductor (Figure 7-3D). At this point in the revolution, the maximum number of flux lines cut the conductor at the south pole. Voltage is now at maximum negative value.

When the magnetic field completes one full revolution, it returns to a parallel position with the magnetic field. Voltage returns to zero. The sine wave is determined by the angle between the magnetic field and the conductor. It is based on the trigonometry sine function of angles. The sine wave shown (Figure 7-4) plots the voltage generated during one revolution.

It is the function of the drive belt to turn the magnetic field. Drive belt tension should be checked periodically to assure proper charging system operation. A loose belt can inhibit charging system efficiency, and a belt that is too tight can cause early bearing failure.

## AC GENERATORS

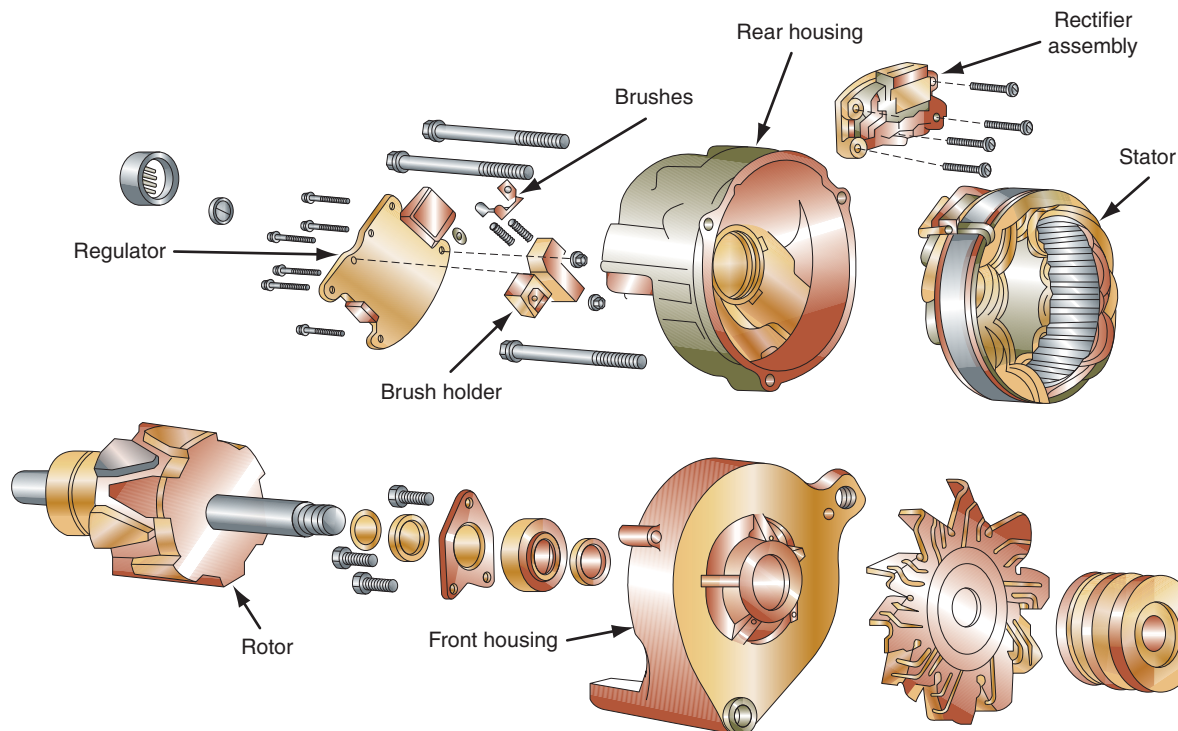
**AUTHOR'S NOTE:** The first charging systems used a DC generator that had two field coils that created a magnetic field. Output voltage was generated in the wire loops of the armature as it rotated inside the magnetic field. Current sent to the battery was through the commutator and the generator's brushes.

The DC generator was unable to produce the sufficient amount of current required when the engine was operating at low speeds. With the addition of more electrical accessories and components, the AC (alternating current) generator, or alternator, replaced the DC generator. The main components of the AC generator are (Figure 7-5)

1. The rotor.
2. Brushes.
3. The stator.
4. The rectifier bridge.
5. The housing.
6. Cooling fan.

### Rotors

The **rotor** creates the rotating magnetic field of the AC generator. It is the portion of the AC generator that is rotated by the drive belt. The rotor is constructed of many turns of copper wire around an iron core. There are metal plates bent over the windings at both ends of the



**FIGURE 7-5** Components of an AC generator.

© Delmar/Cengage Learning

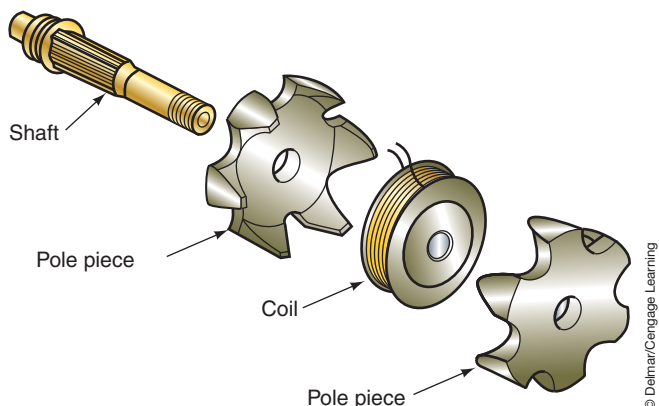
The current flow through the coil is referred to as field current.

Most rotors have twelve to fourteen poles.

rotor windings (Figure 7-6). The poles (metal plates) do not come into contact with each other, but they are interlaced. When current passes through the coil (1.5 to 3.0 amperes), a magnetic field is produced. The strength of the magnetic field is dependent on the amount of current flowing through the coil and the number of windings.

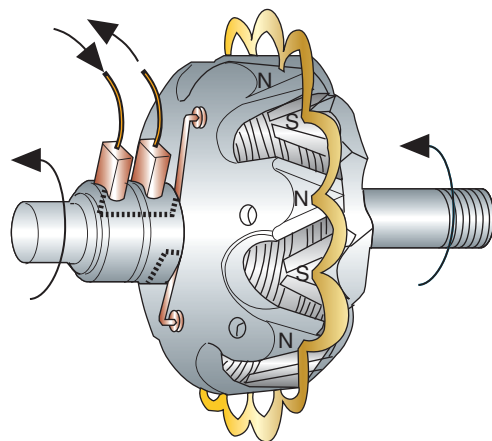
The poles will take on the polarity (north or south) of the side of the coil they touch. The right-hand rule will show whether a north or south pole magnet is created. When the rotor is assembled, the poles alternate from north to south around the rotor (Figure 7-7). As a result of this alternating arrangement of poles, the magnetic flux lines will move in opposite directions between adjacent poles (Figure 7-8). This arrangement provides for several alternating magnetic fields to intersect the stator as the rotor is turning. These individual magnetic fields produce a voltage by induction in the stationary stator windings.

The wires from the rotor coil are attached to two **slip rings** that are insulated from the rotor shaft. The slip rings function much like the armature commutator in the starter motor,



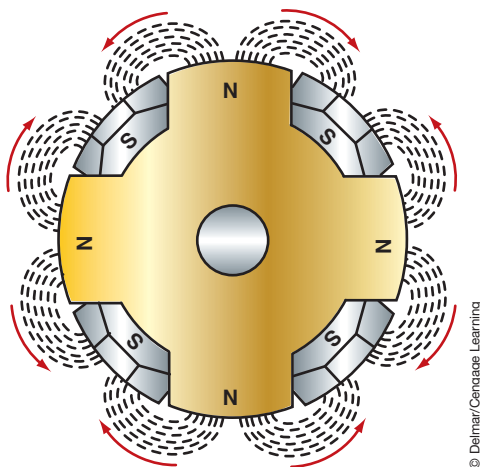
**FIGURE 7-6** Components of a typical AC generator rotor.

© Delmar/Cengage Learning



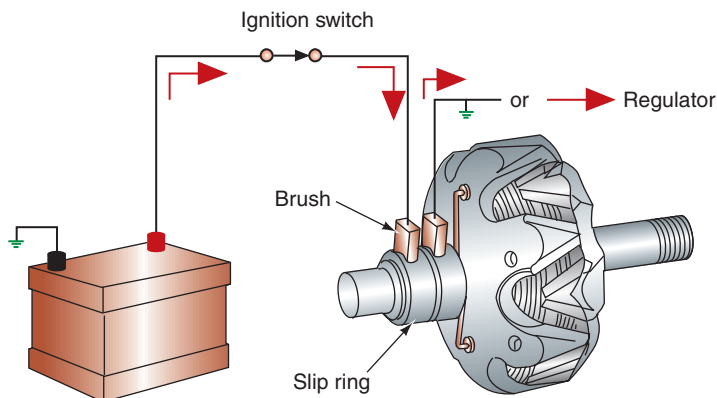
**FIGURE 7-7** The north and south poles of a rotor's field alternate.

© Delmar/Cengage Learning



**FIGURE 7-8** Magnetic flux lines move in opposite directions between the rotor poles.

© Delmar/Cengage Learning



**FIGURE 7-9** The slip rings and brushes provide a current path to the rotor coil.

© Delmar/Cengage Learning

except they are smooth. The insulated stationary carbon brush passes field current into a slip ring, then through the field coil, and back to the other slip ring. Current then passes through a grounded stationary brush (Figure 7-9) or to a voltage regulator.

## Brushes

The field winding of the rotor receives current through a pair of brushes that ride against the slip rings. The brushes and slip rings provide a means of maintaining electrical continuity between stationary and rotating components. The brushes (Figure 7-10) ride the surface of the slip rings on the rotor and are held tight against the slip rings by spring tension provided by the brush holders. The brushes conduct only the field current (2 to 5 amperes). The low current that the brushes must carry contributes to their longer life.

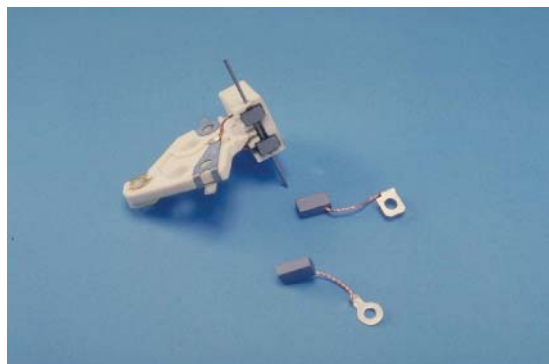
Direct current from the battery is supplied to the rotating field through the field terminal and the insulated brush. The second brush may be the ground brush, which is attached to the AC generator housing or to a voltage regulator.

## Stators

The **stator** contains three main sets of windings wrapped in slots around a laminated, circular iron frame (Figure 7-11). The stator is the stationary coil in which electricity is produced. Each of the three windings has the same number of coils as the rotor has pairs of north and

**Shop Manual**  
Chapter 7, page 294

**Shop Manual**  
Chapter 7, pages  
295, 282



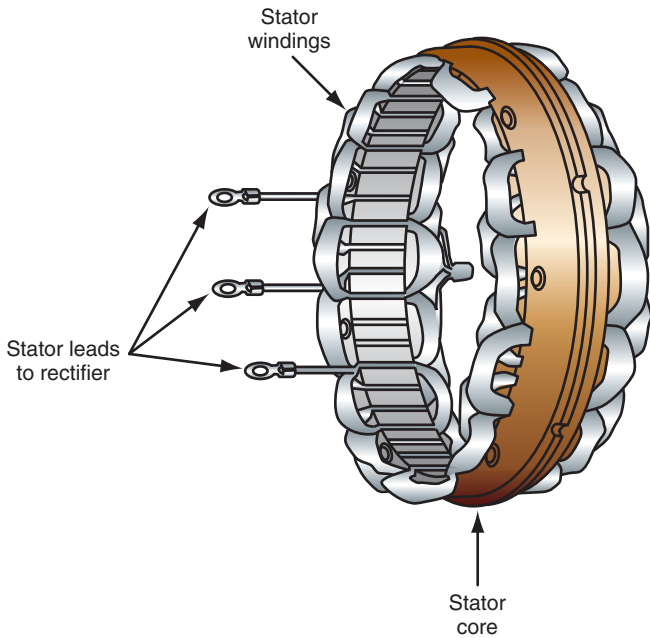
**FIGURE 7-10** Brushes are the stationary electrical contact to the rotor's slip rings

© Delmar/Cengage Learning

south poles. The coils of each winding are evenly spaced around the core. The three sets of windings alternate and overlap as they pass through the core (Figure 7-12). The overlapping is needed to produce the required phase angles.

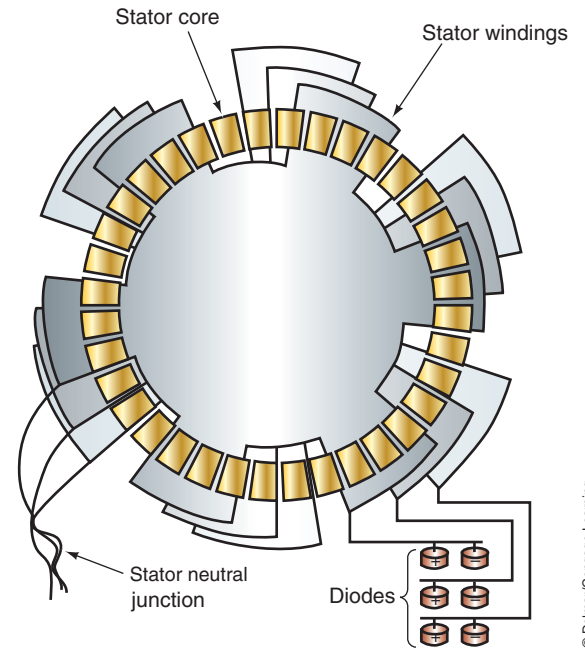
The rotor is fitted inside the stator (Figure 7-13). A small air gap (approximately 0.015 inch or 0.381 mm) is maintained between the rotor and the stator. This gap allows the rotor's magnetic field to energize all of the windings of the stator at the same time and to maximize the magnetic force.

Each group of windings has two leads. The first lead is for the current entering the winding. The second lead is for current leaving. There are two basic means of connecting the leads.



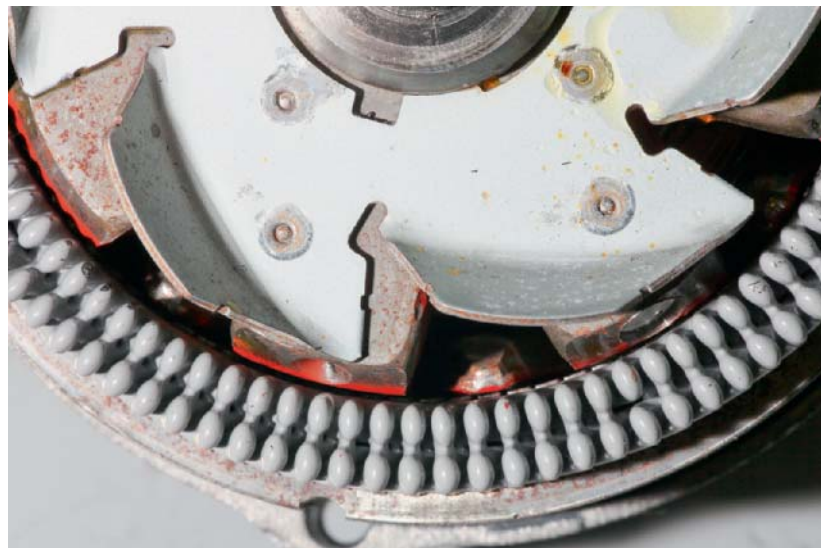
**FIGURE 7-11** Components of a typical stator.

© Delmar/Cengage Learning



**FIGURE 7-12** Overlapping stator windings produce the required phase angles.

© Delmar/Cengage Learning



**FIGURE 7-13** A small air gap between the rotor and the stator maximizes the magnetic force.

© Delmar/Cengage Learning



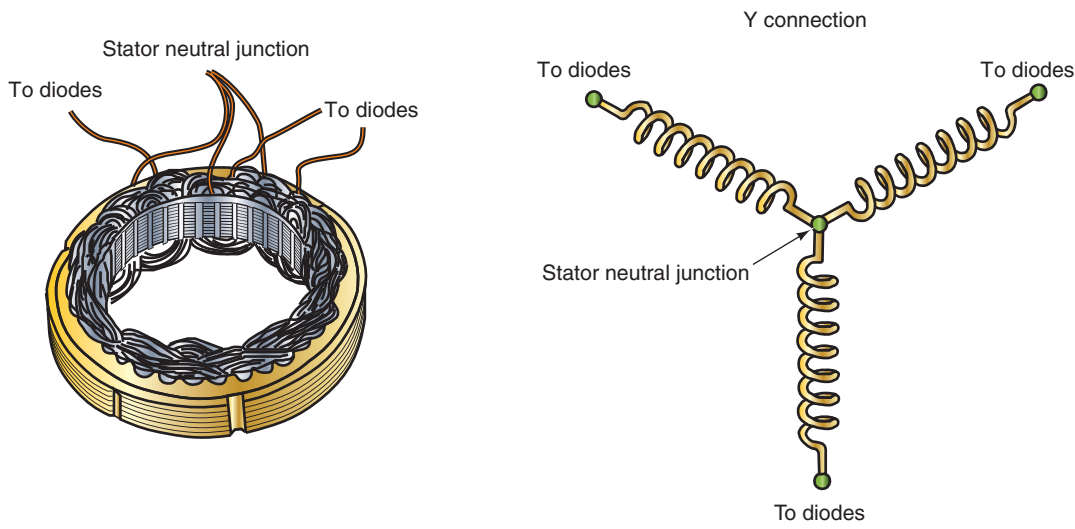


FIGURE 7-14 Wye-connected stator winding.

© Delmar/Cengage Learning

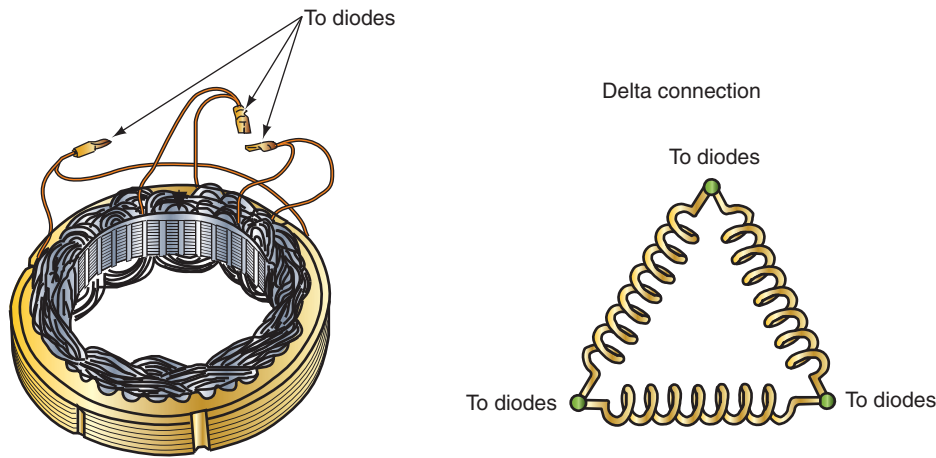


FIGURE 7-15 Delta-connected stator winding.

© Delmar/Cengage Learning

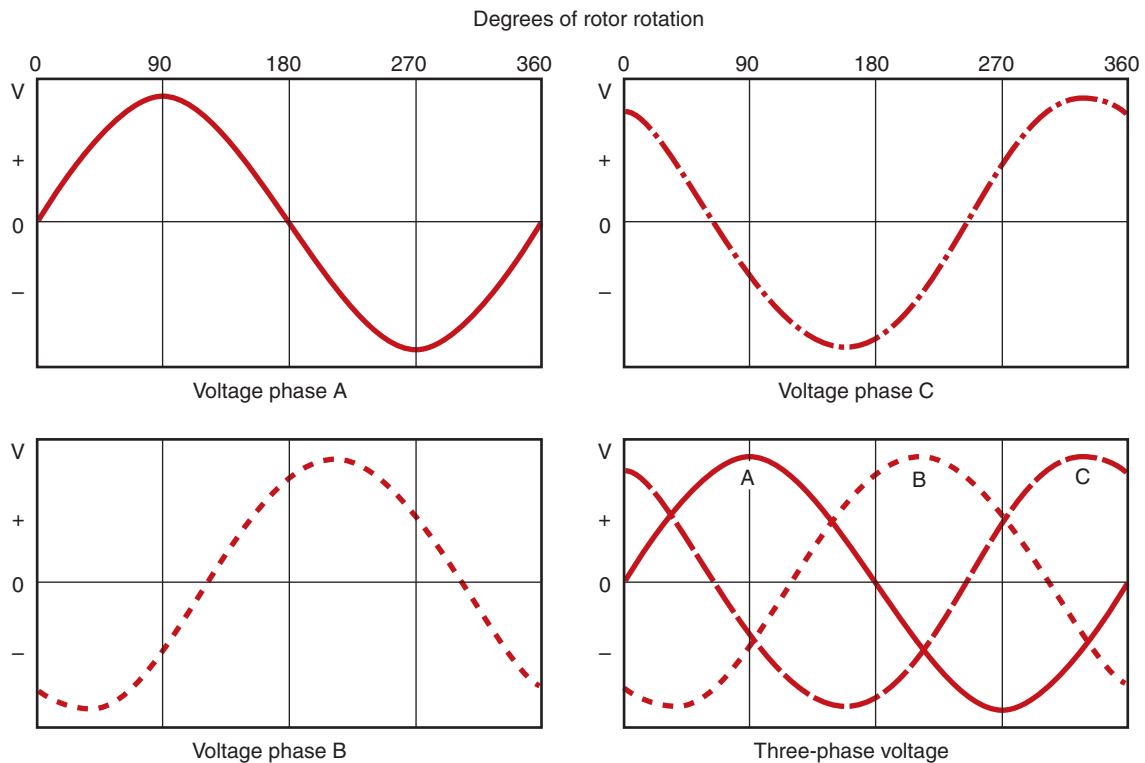
The first method is the **wye wound connection** (Figure 7-14). In the wye connection, one lead from each winding is connected to one common junction. From this junction, the other leads branch out in a Y pattern. A wye wound AC generator is usually found in applications that do not require high amperage output.

The second method of connecting the windings is called the **delta connection** (Figure 7-15). The delta connection attaches the lead of one end of the winding to the lead at the other end of the next winding. The delta connection is commonly used in applications that require high amperage output.

In a wye wound or delta wound stator winding, each group of windings occupies one third of the stator, or 120 degrees of the circle. As the rotor revolves in the stator, a voltage is produced in each loop of the stator at different phase angles. The resulting overlap of sine waves that is produced is shown (Figure 7-16). Each of the sine waves is at a different phase of its cycle at any given time. As a result, the output from the stator is divided into three phases.

The common junction in the wye connected winding is called the stator neutral junction.





**FIGURE 7-16** The voltage produced in each stator winding is added together to create a three-phase voltage.

© Delmar/Cengage Learning

**Shop Manual**  
Chapter 7, pages  
283, 296

The rectifier bridge is also known as a rectifier stack.

## Diode Rectifier Bridge

The battery and the electrical system cannot accept or store AC voltage. For the vehicle's electrical system to be able to use the voltage and current generated in the AC generator, the AC current needs to be converted to DC current. This process is called **rectification**. A split-ring commutator cannot be used to rectify AC current to DC current because the stator is stationary in an AC generator. Instead, a **diode rectifier bridge** is used to change the current in an AC generator (Figure 7-17). Acting as a one-way check valve, the diodes switch the current flow back and forth so that it flows from the AC generator in only one direction.

When AC current reverses itself, the diode blocks and no current flows. If AC current passes through a positively biased diode, the diode will block off the negative pulse. The result

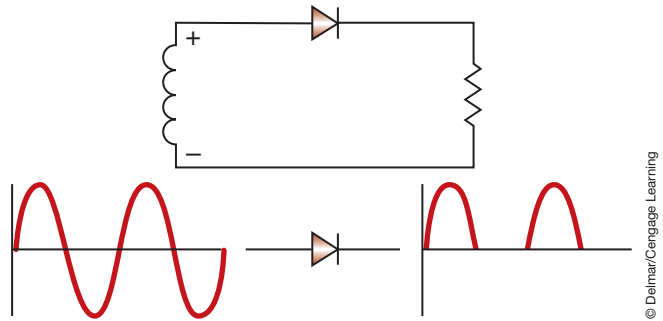


© Delmar/Cengage Learning

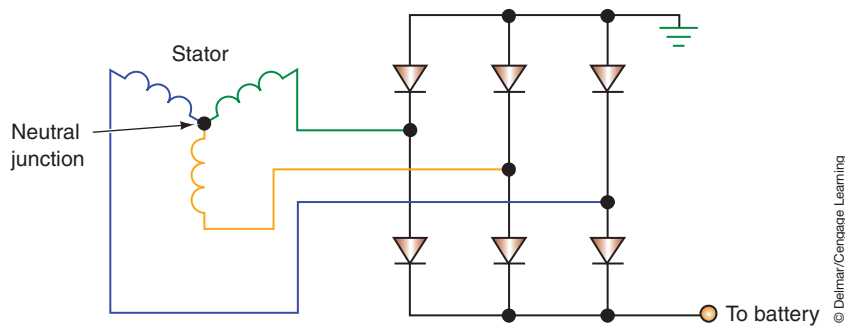
**FIGURE 7-17** General Motors' rectifier bridge.

is the scope pattern shown in Figure 7-18. The AC current has been changed to a pulsing DC current. This process is called **half-wave rectification**.

An AC generator usually uses a pair of diodes for each stator winding, for a total of six diodes (Figure 7-19). Three of the diodes are positive biased and are mounted in a **heat sink** to dissipate the heat (Figure 7-20). The three remaining diodes are negative biased and are attached directly to the frame of the AC generator (Figure 7-21). By using a pair of diodes that are reverse-biased to each other, rectification of both sides of the AC sine wave is achieved (Figure 7-22). The process of converting both sides of the sine wave to a DC voltage is called



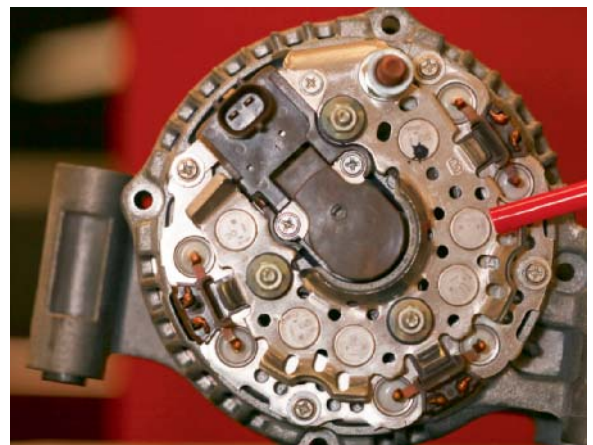
**FIGURE 7-18** AC current rectified to a pulsating DC current after passing through a positive-biased diode. This is called half-wave rectification.



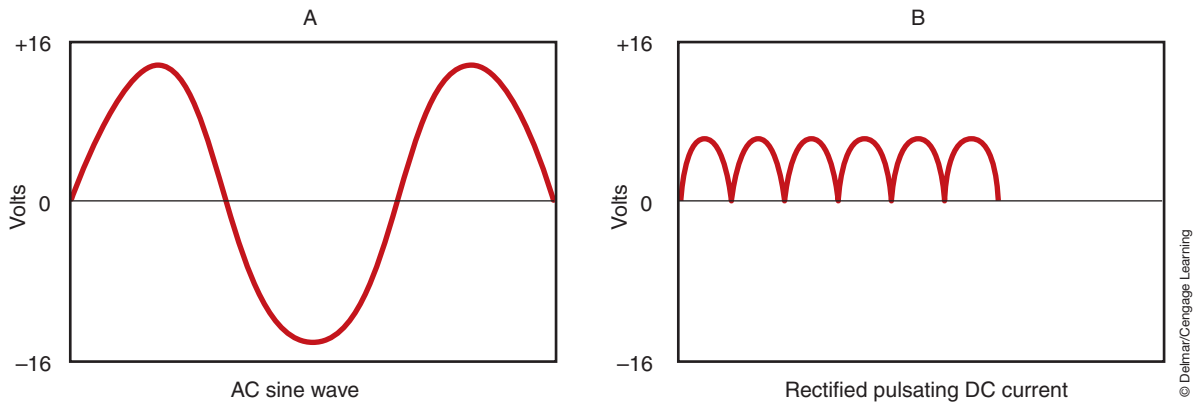
**FIGURE 7-19** A simplified schematic of the AC generator windings connected to the diode rectifier bridge.



**FIGURE 7-20** The positive-biased diodes are mounted into a heat sink to provide protection.



**FIGURE 7-21** Negative-biased diodes pressed into the AC generator housing.



**FIGURE 7-22** Full-wave rectification uses both sides of the AC sine wave to create a pulsating DC current.

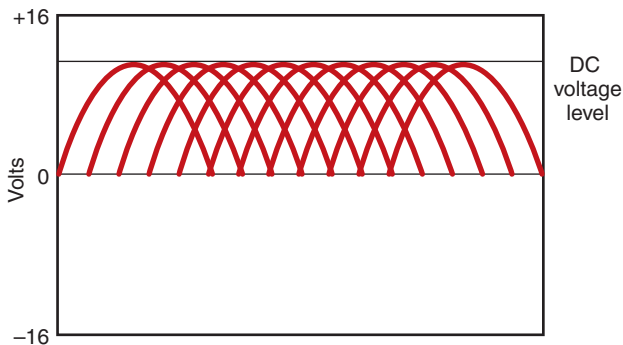
**full-wave rectification.** The negative-biased diodes allow for conducting current from the negative side of the AC sine wave and putting this current into the circuit. Diode rectification changes the negative current into positive output.

With each stator winding connected to a pair of diodes, the resultant waveform of the rectified voltage would be similar to that shown (Figure 7-23). With six peaks per revolution, the voltage will vary only slightly during each cycle.

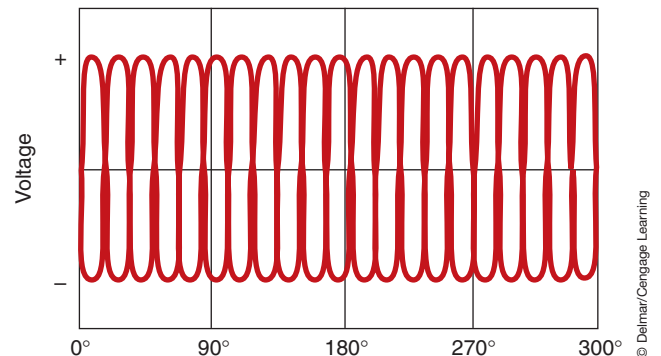
The examples used so far have been for single-pole rotors in a three-winding stator. Most AC generators use either a twelve- or fourteen-pole rotor. Each pair of poles produces one complete sine wave in each winding per revolution. During one revolution, a fourteen-pole rotor will produce seven sine waves. The rotor generates three overlapping sine wave voltage cycles in the stator. The total output of a fourteen-pole rotor per revolution would be twenty-one sine wave cycles (Figure 7-24). With final rectification, the waveform would be similar to the one shown (Figure 7-25).

Full-wave rectification is desired because using only half-wave rectification wastes the other half of the AC current. Full-wave rectification of the stator output uses the total potential by redirecting the current from the stator windings so that all current is in one direction.

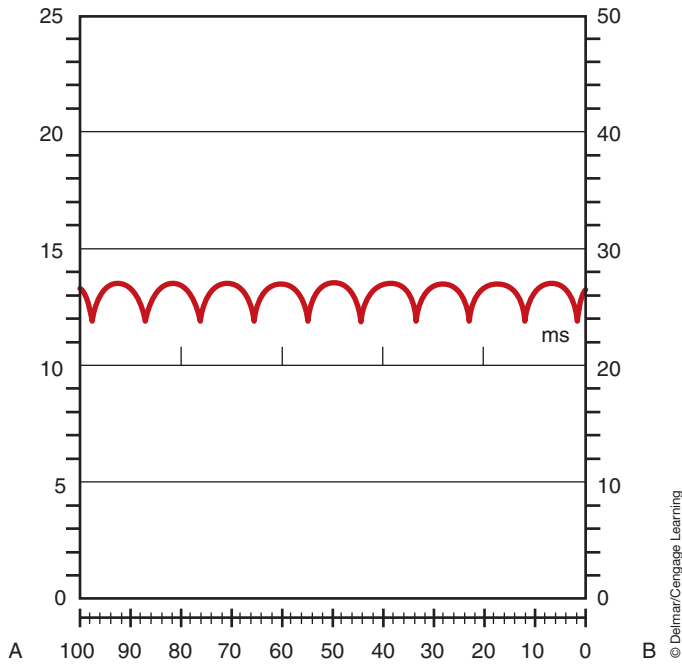
A wye wound stator with each winding connected to a pair of diodes is shown (Figure 7-26). Each pair of diodes has one negative and one positive diode. During rotor movement, two stator windings will be in series and the third winding will be neutral. As the rotor revolves, it will energize a different set of windings. Also, current flow through the windings is reversed as the rotor passes. Current in any direction through two windings in series will produce DC current.



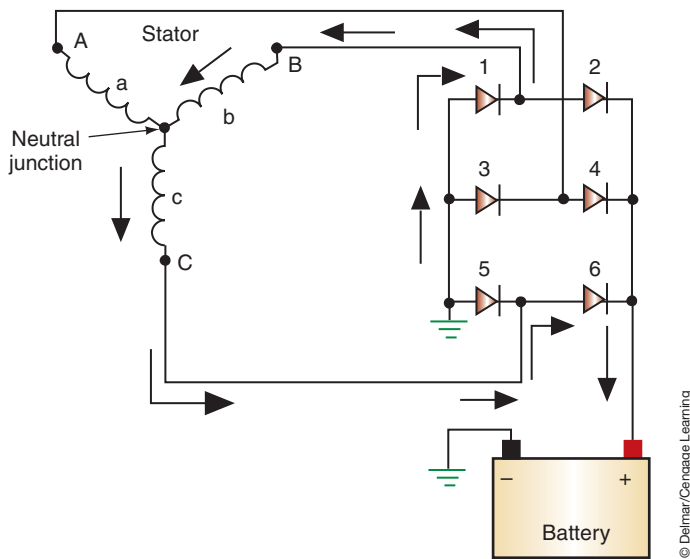
**FIGURE 7-23** With three-phase rectification, the DC voltage level is uniform.



**FIGURE 7-24** Sine wave cycle of a 14-pole rotor and three-phase stator.



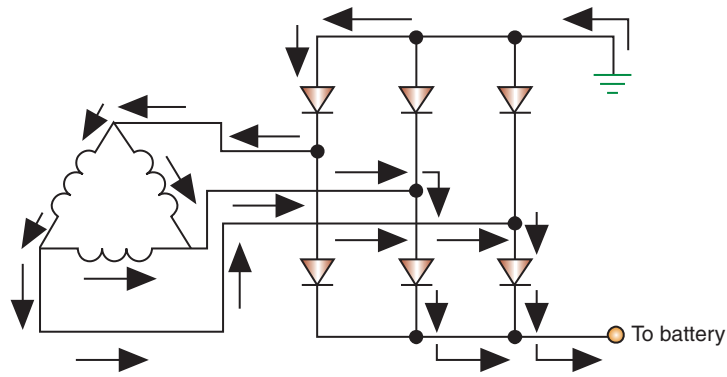
**FIGURE 7-25** Rectified AC output has a ripple pattern that can be shown on an oscilloscope.



**FIGURE 7-26** Current flow through a wye-wound stator.

The action that occurs when the delta wound stator is used is shown (Figure 7-27). Instead of two windings in series, the three windings of the delta stator are in parallel. This makes more current available because the parallel paths allow more current to flow through the diodes. Since the three outputs of the delta winding are in parallel, current flows from each winding continuously.

**AUTHOR'S NOTE:** Not only do the diodes rectify stator output, but they also block battery drain back when the engine is not running.



© Delmar/Cengage Learning

FIGURE 7-27 Current flow through a delta-wound stator.

**Shop Manual**

Chapter 7, page 294

## AC Generator Housing and Cooling Fan

Most AC generator housings are a two-piece construction, made from cast aluminum (Figure 7-28). The two end frames provide support of the rotor and the stator. In addition, the end frames contain the diodes, regulator, heat sinks, terminals, and other components of the AC generator. The two end pieces are referred to as:

1. The drive end housing: This housing holds a bearing to support the front of the rotor shaft. The rotor shaft extends through the drive end housing and holds the drive pulley and cooling fan.
2. The slip ring end housing: This housing also holds a rotor shaft that supports a bearing. In addition, it contains the brushes and has all of the electrical terminals. If the AC generator has an integral regulator, it is also contained in this housing.

The cooling fan draws air into the housing through the openings at the rear of the housing. The air leaves through openings behind the cooling fan (Figure 7-29).

## Liquid-Cooled Generators

High output generators have a tendency to have higher internal temperatures that can shorten the life of the diodes. To help reduce diode temperatures, some manufacturers are using a liquid cooled generator (Figure 7-30). In addition, since these generators do not use

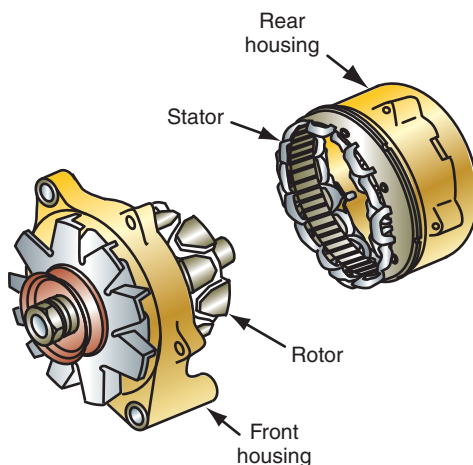


FIGURE 7-28 Typical two-piece AC generator housing.

© Delmar/Cengage Learning

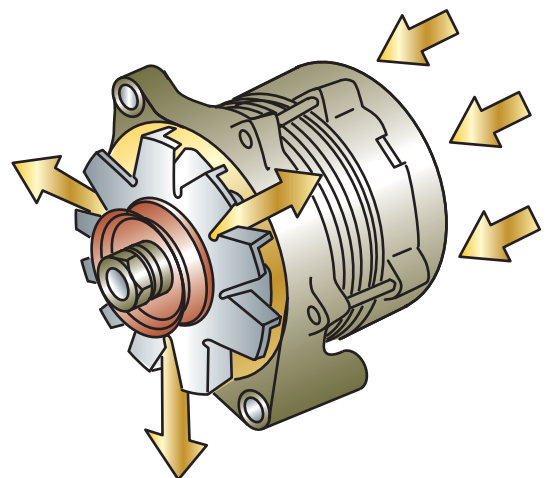
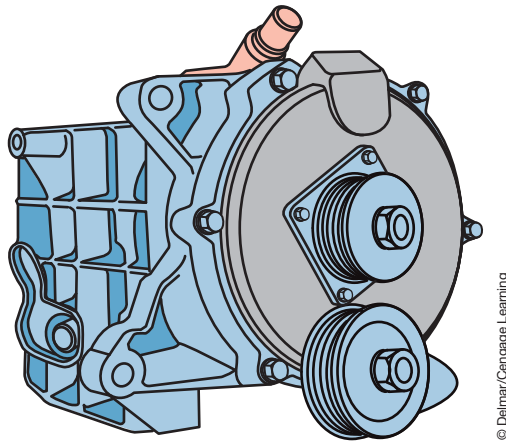


FIGURE 7-29 The cooling fan draws air in from the rear of the AC generator to keep the diodes cool.

© Delmar/Cengage Learning



© Delmar/Cengage Learning

FIGURE 7-30 Water-cooled generator.

a fan, underhood noises are reduced. The water-cooled generator has water jackets cast into their housing and is connected to the engine's cooling system by hoses.

## AC GENERATOR CIRCUITS

There are three principal circuits used in an AC generator:

1. The charging circuit: Consists of the stator windings and rectifier circuits.
2. The excitation circuit: Consists of the rotor field coil and the electrical connections to the coil.
3. The preexcitation circuit: Supplies the initial current for the field coil that starts the buildup of the magnetic field.

For the AC generator to produce current, the field coil must develop a magnetic field. The AC generator creates its own field current in addition to its output current.

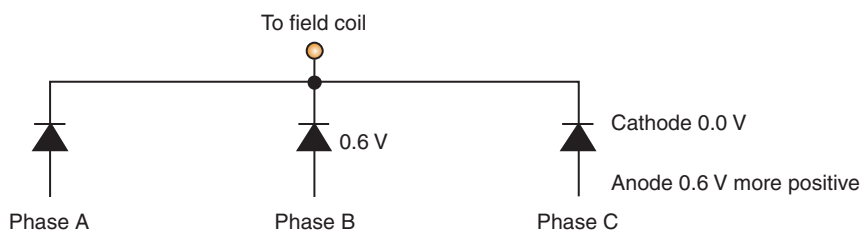
For excitation of the field to occur, the voltage induced in the stator rises to a point that it overcomes the forward voltage drop of at least two of the rectifier diodes. Before the **diode trio** can supply field current, the anode side of the diode must be at least 0.6 V more positive than the cathode side (Figure 7-31). When the ignition switch is turned on, the warning lamp current acts as a small magnetizing current through the field (Figure 7-32). This current preexcites the field, reducing the speed required to start its own supply of field current.

### Shop Manual

Chapter 7, page 296

The **diode trio** is used by some manufacturers to rectify current from the stator so that it can be used to create the magnetic field in the field coil of the rotor. This eliminates extra wiring.

**AUTHOR'S NOTE:** If the battery is completely discharged, the vehicle cannot be push started because there is no excitation of the field coil.



© Delmar/Cengage Learning

FIGURE 7-31 The diode trio connects the phase windings to the field. To conduct, there must be 0.6 V more positive on the anode side of the diodes.



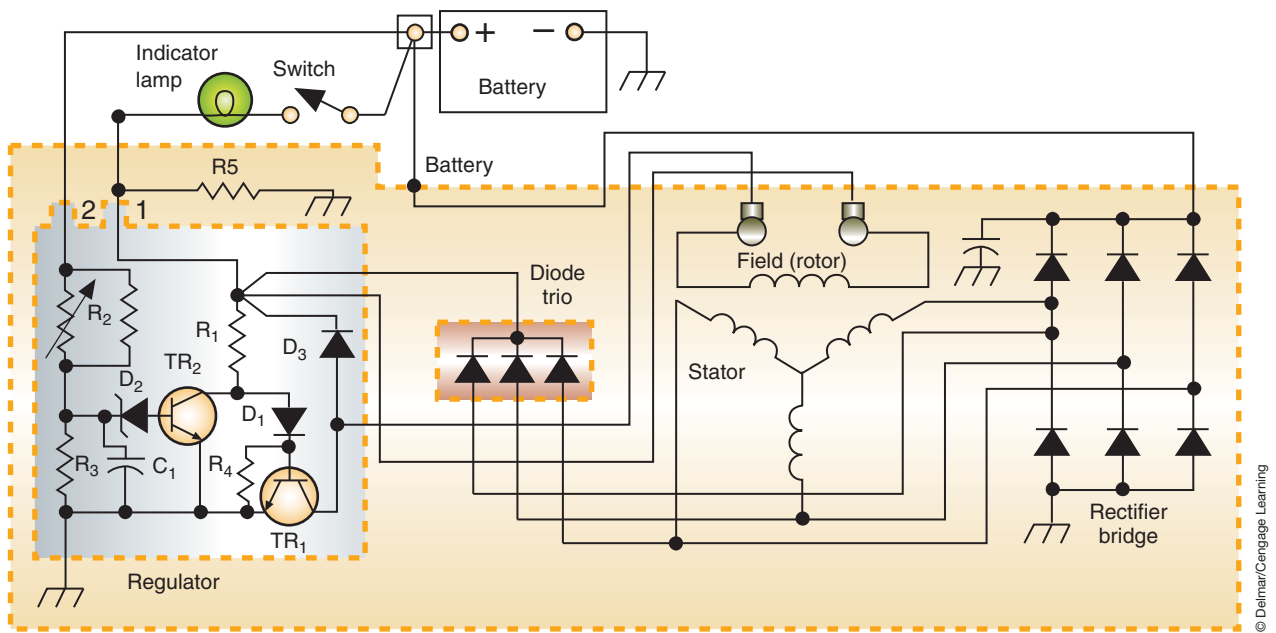


FIGURE 7-32 Schematic of a charging system.

## AC GENERATOR OPERATION OVERVIEW

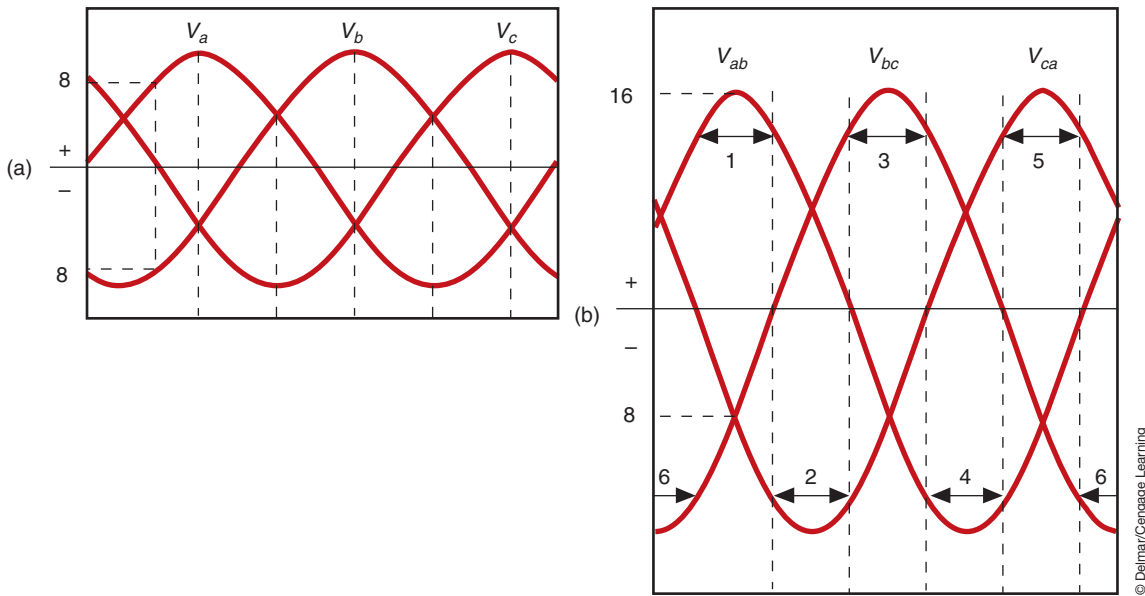
When the engine is running, the drive belt spins the rotor inside the stator windings. This magnetic field inside the rotor generates a voltage in the windings of the stator. Field current flowing through the slip rings to the rotor creates alternating north and south poles on the rotor.

The induced voltage in the stator is an alternating voltage because the magnetic fields are alternating. As the magnetic field begins to induce voltage in the stator's windings, the induced voltage starts to increase. The amount of voltage will peak when the magnetic field is the strongest. As the magnetic field begins to move away from the stator windings, the amount of voltage will start to decrease. Each of the three windings of the stator generates voltage, so the three combine to form a three-phase voltage output.

In the wye connection (refer to Figure 7-26), output terminals (A, B, and C) apply voltage to the rectifier. Because only two stator windings apply voltage (because the third winding is always connected to diodes that are reverse-biased), the voltages come from points A to B, B to C, and C to A.

To determine the amount of voltage produced in the two stator windings, find the difference between the two points. For example, to find the voltage applied from points A and B, subtract the voltage at point B from the voltage at point A. If the voltage at point A is 8 volts positive and the voltage at point B is 8 volts negative, the difference is 16 volts. This procedure can be performed for each pair of stator windings at any point in time to get the sine wave patterns (Figure 7-33). The voltages in the windings are designated as  $V_a$ ,  $V_b$ , and  $V_c$ . Designations of  $V_{ab}$ ,  $V_{bc}$ , and  $V_{ca}$  refer to the voltage difference in the two stator windings. In addition, the numbers refer to the diodes used for the voltages generated in each winding pair.

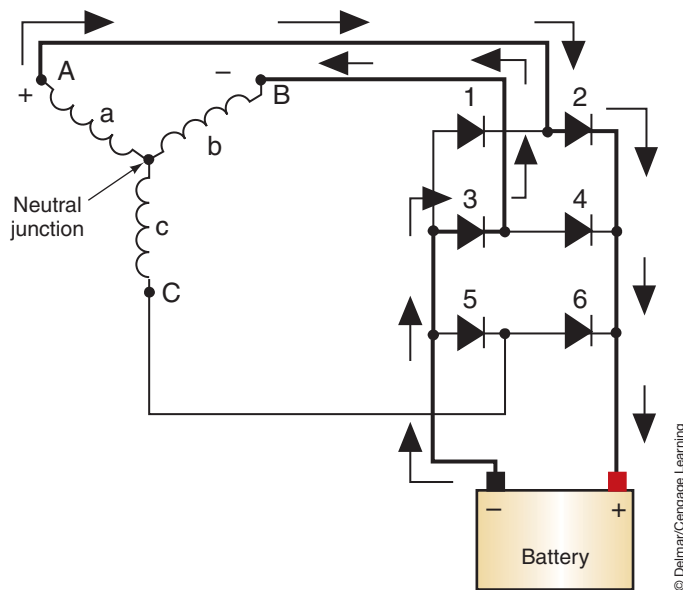
**AUTHOR'S NOTE:** Alternating current is constantly changing, so this formula would have to be performed at several different times.



**FIGURE 7-33 (A) Individual stator winding voltages; (B) voltages across the stator terminal A, B, and C.**

The current induced in the stator passes through the diode rectifier bridge, consisting of three positive and three negative diodes. At this point, there are six possible paths for the current to follow. The path that is followed depends on the stator terminal voltages. If the voltage from points A and B is positive (point A is positive in respect to point B), current is supplied to the positive terminal of the battery from terminal A through diode 2 (Figure 7-34). The negative return path is through diode 3 to terminal B.

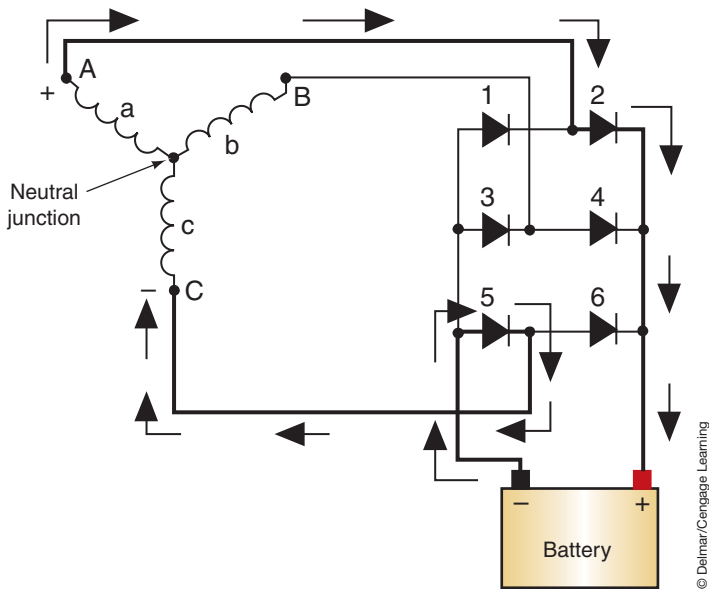
Both diodes 2 and 3 are forward-biased. The stator winding labeled C does not produce current because it is connected to diodes that are reverse-biased. The stator current is rectified to DC current to be used for charging the battery and supplying current to the vehicle's electrical system.



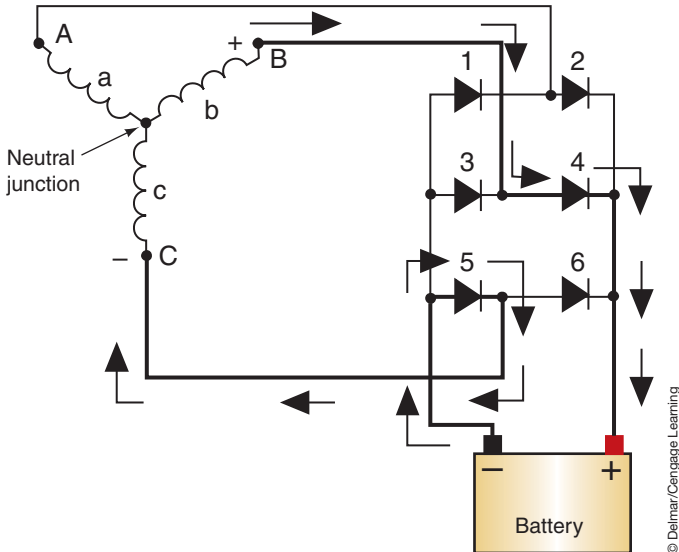
**FIGURE 7-34 Current flow when terminals A and B are positive.**

When the voltage from terminals C and A is negative (point C is negative in respect to point A), current flow to the battery positive terminal is from terminal A through diode 2 (Figure 7-35). The negative return path is through diode 5 to terminal C.

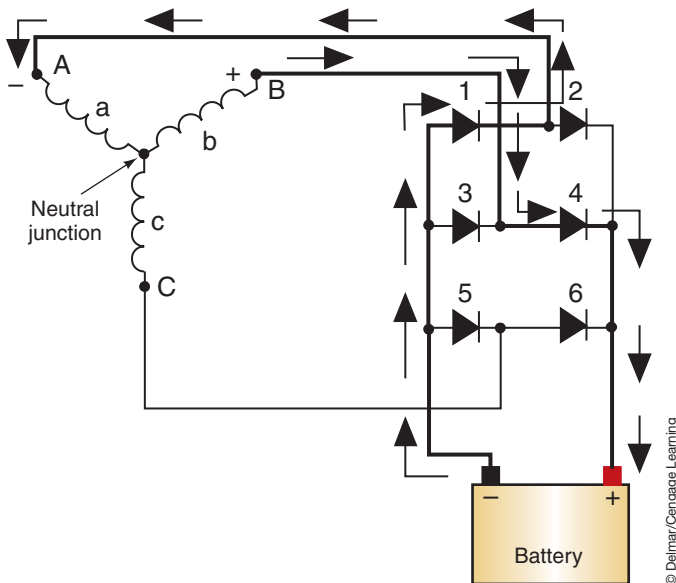
This procedure is repeated through the four other current paths (Figures 7-36 through 7-39).



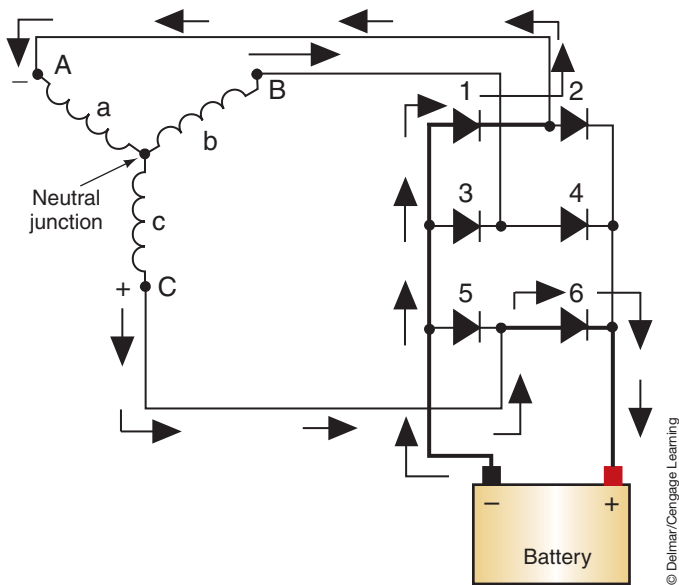
**FIGURE 7-35** Current flow when terminals A and C are negative.



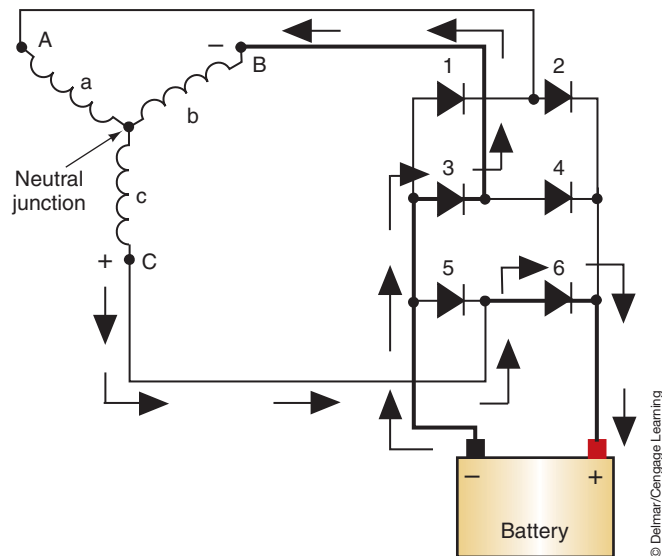
**FIGURE 7-36** Current flow when terminals B and C are positive.



**FIGURE 7-37** Current flow when terminals A and B are negative.



**FIGURE 7-38** Current flow when terminals A and C are positive



**FIGURE 7-39** Current flow when terminals B and C are negative.

## REGULATION

The battery, and the rest of the electrical system, must be protected from excessive voltages. To prevent early battery and electrical system failure, regulation of the charging system voltage is very important. Also, the charging system must supply enough current to run the vehicle's electrical accessories when the engine is running.

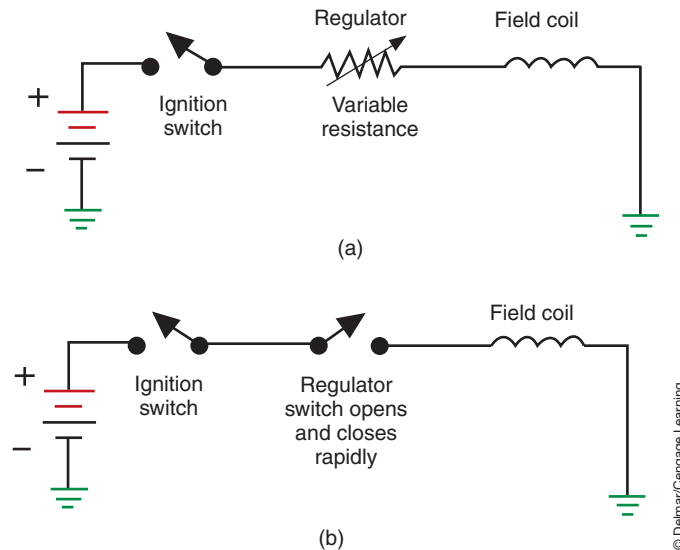
AC generators do not require current limiters; because of their design, they limit their own current output. Current limit is the result of the constantly changing magnetic field because of the induced AC current. As the magnetic field changes, an opposing current is induced in the stator windings. This **inductive reactance** in the AC generator limits the maximum current that the AC generator can produce. Even though current (amperage) is limited by its operation, voltage is not. The AC generator is capable of producing as high as 250 volts, if it were not controlled.

Regulation of voltage is done by varying the amount of field current flowing through the rotor. The higher the field current, the higher the output voltage. Control of field current can be done either by regulating the resistance in series with the field coil or by turning the field circuit on and off (Figure 7-40). By controlling the amount of current in the field coil, control of the field current and the AC generator output is obtained. To ensure a full battery charge, and operation of accessories, most voltage regulators are set for a system voltage between 13.5 and 14.5 volts.

The regulator must have system voltage as an input in order to regulate the output voltage. The input voltage to the AC generator is called **sensing voltage**. If sensing voltage is below the regulator setting, an increase in charging voltage output results by increasing field current. Higher sensing voltage will result in a decrease in field current and voltage output. A vehicle being driven with no accessories on and a fully charged battery will have a high sensing voltage. The regulator will reduce the charging voltage until it is at a level to run the ignition system while trickle charging the battery. If a heavy load is turned on (such as the headlights), the additional draw will cause a drop in the battery voltage. The regulator will sense this low system voltage and will increase current to the rotor. This will allow more current to the field windings. With the increase of field current, the magnetic field is stronger and AC generator voltage output is increased. When the load is turned off, the regulator senses the rise in system voltage and cuts back the amount of field current and ultimately AC generator voltage output.

**Shop Manual**

Chapter 7, page 282



**FIGURE 7-40** The regulator can control the field current by (A) controlling the resistance in series with the coil, or (B) by switching the field on and off.

Temperature	Volts	
	Minimum	Maximum
20°F	14.3	15.3
80°F	13.8	14.4
140°F	13.3	14.0
Over 140°F	Less than 13.3	—

**FIGURE 7-41** Chart indicating relationship between temperature and charge rate.

Another input that affects regulation is temperature. Because ambient temperatures influence the rate of charge that a battery can accept, regulators are temperature compensated (Figure 7-41). Temperature compensation is required because the battery is more reluctant to accept a charge at lower ambient temperatures. The regulator will increase the system voltage until it is at a higher level so the battery will accept it.

## Field Circuits

To properly test and service the charging system, it is important to identify the field circuit being used. Automobile manufacturers use three basic types of field circuits. The first type is called the A circuit. It has the regulator on the ground side of the field coil. The B+ for the field coil is picked up from inside the AC generator (Figure 7-42). By placing the regulator on the ground side of the field coil, the regulator will allow the control of field current by varying the current flow to ground.

The second type of field circuit is called the B circuit. In this case, the voltage regulator controls the power side of the field circuit. Also, the field coil is grounded from inside the AC generator.

**AUTHOR'S NOTE:** To remember these circuits: Think of “A” for “After” the field and “B” for “Before” the field.

### Shop Manual

Chapter 7, page 274

The A circuit is called an external grounded field circuit.

Usually the B circuit regulator is mounted externally of the AC generator. The B circuit is an internally grounded circuit.

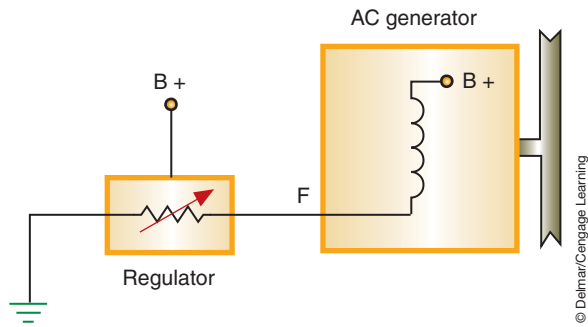


FIGURE 7-42 Simplified diagram of an A circuit field.

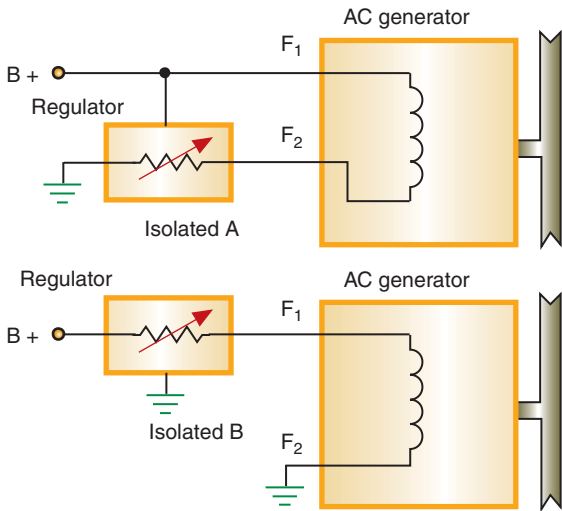


FIGURE 7-43 In the isolated circuit field AC generator, the regulator can be installed on either side of the field.

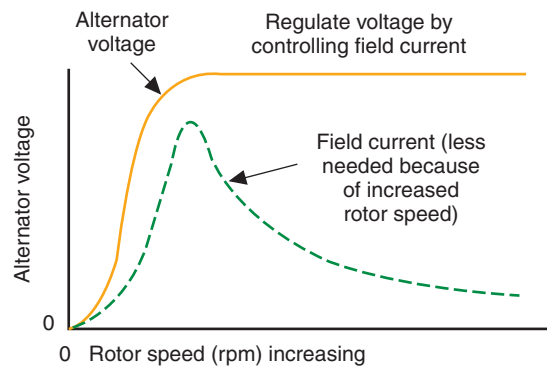


FIGURE 7-44 Graph showing the relationship between field current, rotor speed, and regulated voltage changes depending on electrical load.

The third type of field circuit is called the isolated field. The AC generator has two field wires attached to the outside of the case. The voltage regulator can be located on either the ground (A circuit) or on the B+ (B circuit) side (Figure 7-43).

Regardless of which type is used, the field circuit is designed to control the amount of voltage output by controlling the amount of current through the field windings. The relationship between the field current, rotor speed, and regulated voltage is illustrated in Figure 7-44. As rotor speed increases, field current must be decreased to maintain regulated voltage.

## Electronic Regulators

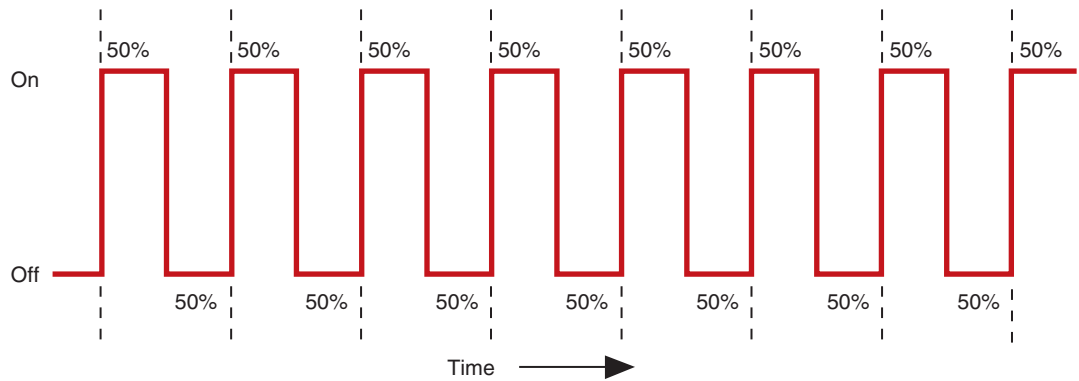
The **electronic regulator** uses solid-state circuitry to perform the regulatory functions. Electronic regulators can be mounted either externally or internally of the AC generator. There are no moving parts, so it can cycle between 10 and 7,000 times per second. This quick cycling provides more accurate control of the field current through the rotor.

**Pulse width modulation** controls AC generator output by varying the amount of time the field coil is energized. For example, assume that a vehicle is equipped with a 100-ampere generator. If the electrical demand placed on the charging system requires 50 amperes of current, the regulator would energize the field coil for 50% of the time (Figure 7-45). If the electrical system's demand was increased to 75 amperes, the regulator would energize the field coil 75% of the cycle time.

Isolated field AC generators pick up B+ and ground externally.

**Shop Manual**  
Chapter 7, page 282





© Delmar/Cengage Learning

**FIGURE 7-45** Pulse width modulation with 50% on time.

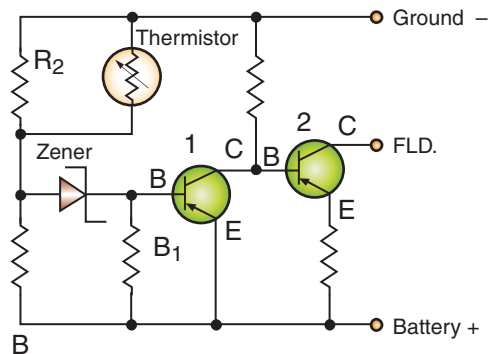
The electronic regulator uses a zener diode that blocks current flow until a specific voltage is obtained, at which point it allows the current to flow. An electronic regulator is shown (Figure 7-46).

Battery voltage is applied to the anode side of the zener diode as well as to the base of transistor number 1. No current will flow through the zener diode, since battery voltage is too low to push through the zener. However, as the AC generator produces voltage, the voltage at the anode will increase until it reaches the upper limit (14.5 volts) and is able to push through the zener diode. Current will now flow from the battery, through the resistor ( $R_1$ ) to the anode, through the zener diode, through the resistor ( $R_2$ ) and thermistor in parallel, and to ground. Since current is flowing, each resistance in the circuit will drop voltage. As a result, voltage to the base of transistor number 1 will be less than the voltage applied to the emitter. Since transistor number 1 is a PNP transistor and the base voltage is less than the emitter voltage, transistor number 1 is turned on. The base of transistor number 2 will now have battery voltage applied to it. Since the voltage applied to the base of transistor number 2 is greater than that applied to its emitter, transistor number 2 is turned off. Transistor number 2 is in control of the field current and generator output.

The thermistor changes circuit resistance according to temperature. This provides for the temperature-related voltage change necessary to keep the battery charged in cold-weather conditions.

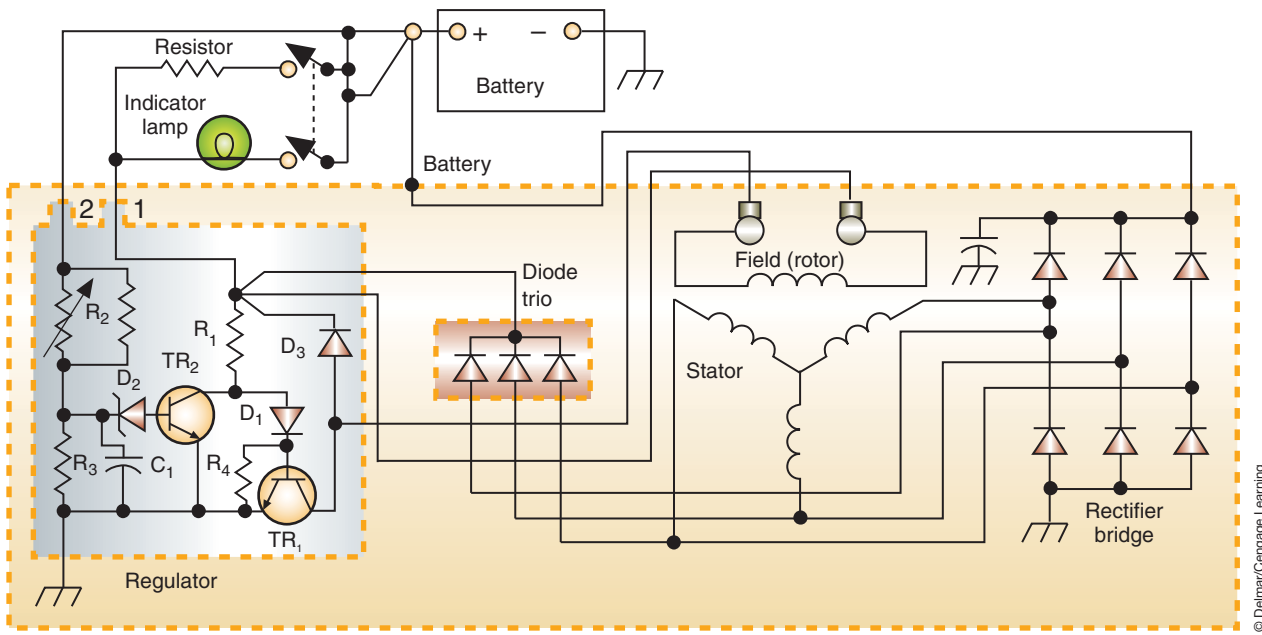
Many manufacturers are installing the voltage regulator inside the AC generator. This eliminates some of the wiring needed for external regulators. The diode trio rectifies AC current from the stator to DC current that is applied to the field windings (Figure 7-47).

Current flow with the engine off and the ignition switch in the RUN position is illustrated (Figure 7-48). Battery voltage is applied to the field through the common point above



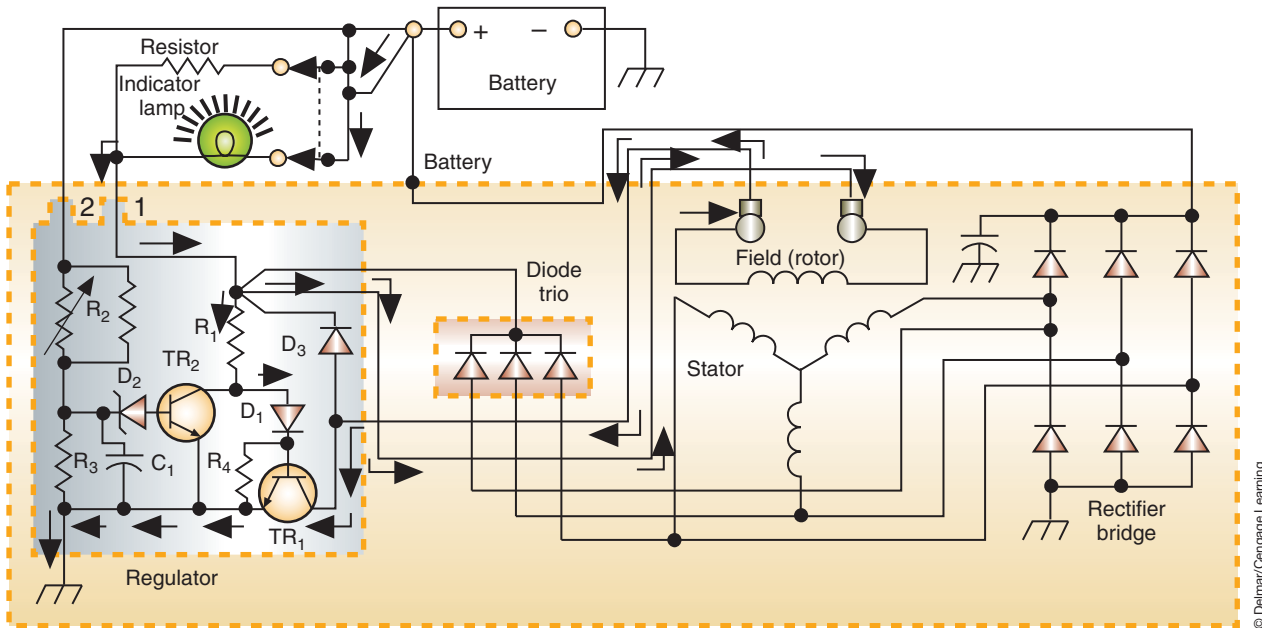
© Delmar/Cengage Learning

**FIGURE 7-46** A simplified circuit diagram of an electronic regulator utilizing a zener diode.



© Delmar/Cengage Learning

**FIGURE 7-47** AC generator circuit diagram with internal regulator. This system uses a diode trio to rectify stator current to be applied to the field coil. The resistor above the indicator lamp is used to ensure current will flow through the terminal 1 if the lamp burns out.

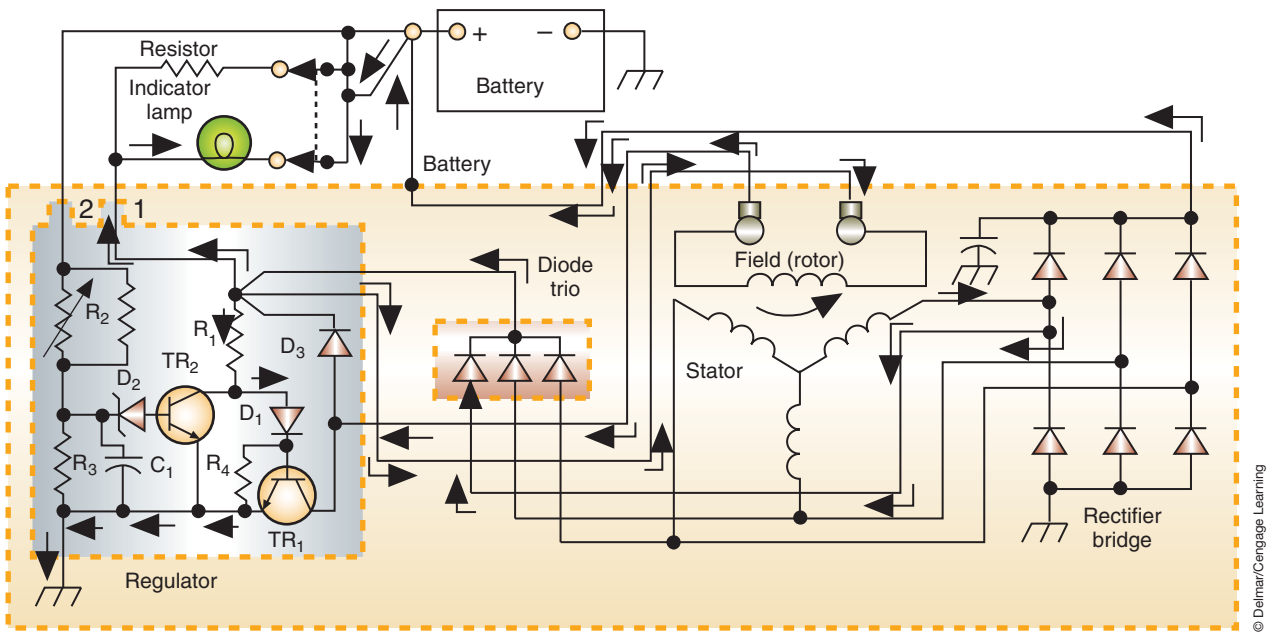


© Delmar/Cengage Learning

**FIGURE 7-48** Current flow to the rotor with the ignition switch in the RUN position and the engine OFF.

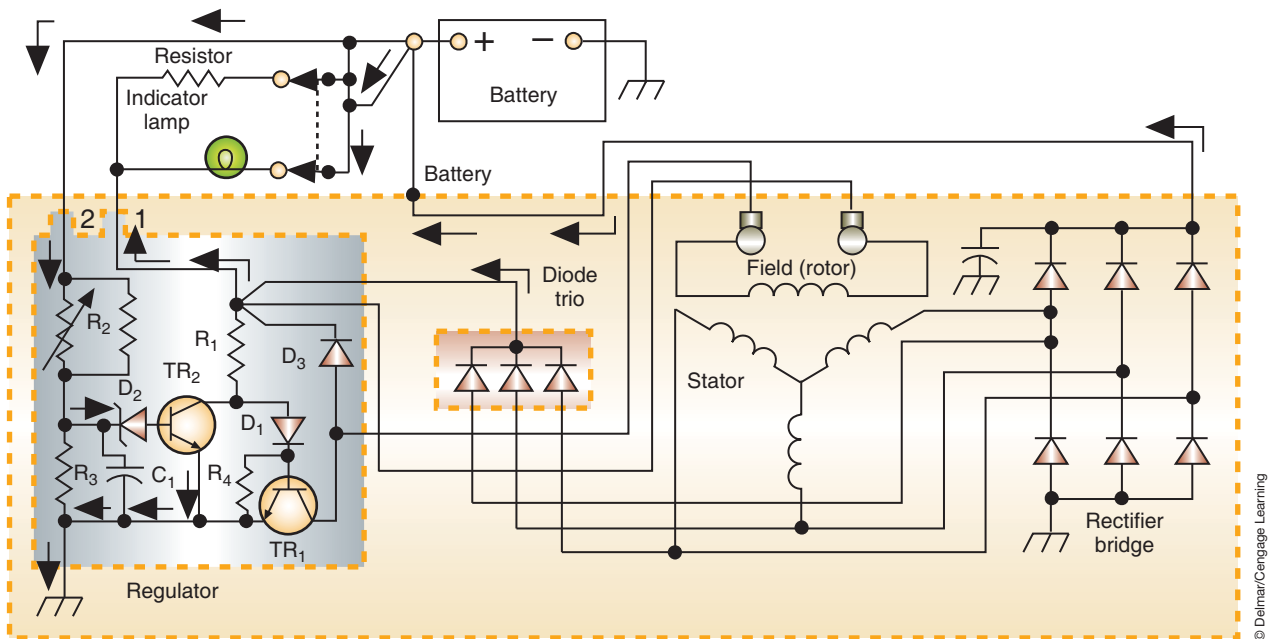
$R_1$ .  $TR_1$  conducts the field current coming from the field coil, producing a weak magnetic field. The indicator lamp lights because  $TR_1$  directs current to ground and completes the lamp circuit.

Current flow with the engine running is illustrated (Figure 7-49). When the AC generator starts to produce voltage, the diode trio will conduct and battery voltage is available for the field and terminal 1 at the common connection. Placing voltage on both sides of the lamp gives the same voltage potential at each side; therefore, current doesn't flow and the lamp goes out.



**FIGURE 7-49** Current flow with the engine running and AC generator producing voltage.

Current flow as the voltage output is being regulated is illustrated (Figure 7-50). The sensing circuit from terminal 2 passes through a thermistor to the zener diode ( $D_2$ ). When the system voltage reaches the upper voltage limit of the zener diode, the zener diode conducts current to  $TR_2$ . When  $TR_2$  is biased, it opens the field coil circuit and current stops flowing through the field coil. Regulation of this switching on and off is based on the sensing voltage received through terminal 2. With the circuit to the field coil opened, the sensing voltage decreases and the zener diode stops conducting.  $TR_2$  is turned off and the circuit for the field coil is closed.



**FIGURE 7-50** When the system voltage is high enough to allow the zener diode to conduct,  $TR_2$  is turned on and  $TR_1$  is shut off, which opens the field circuit.

## Computer-Controlled Regulation

On many vehicles after the mid-1980s, the regulator function has been incorporated into the powertrain control module (PCM). The operation is similar to the internal electronic regulator (Figure 7-51). Regulation of the field circuit is through the ground (A circuit). However, in recent years there has been an increase in manufacturers that will control the field circuit by use of high-side drivers.

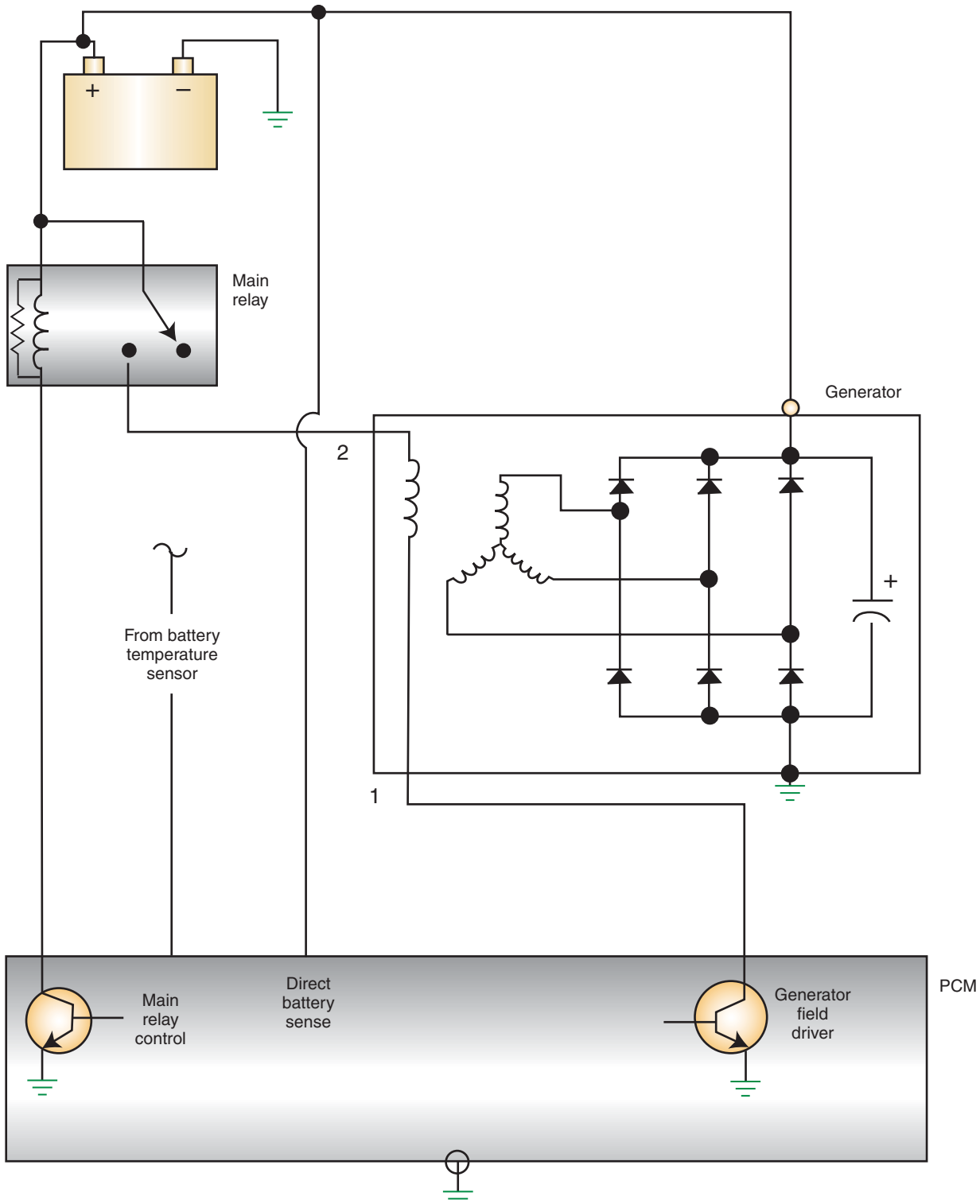


FIGURE 7-51 Computer-controlled voltage regulator circuit.

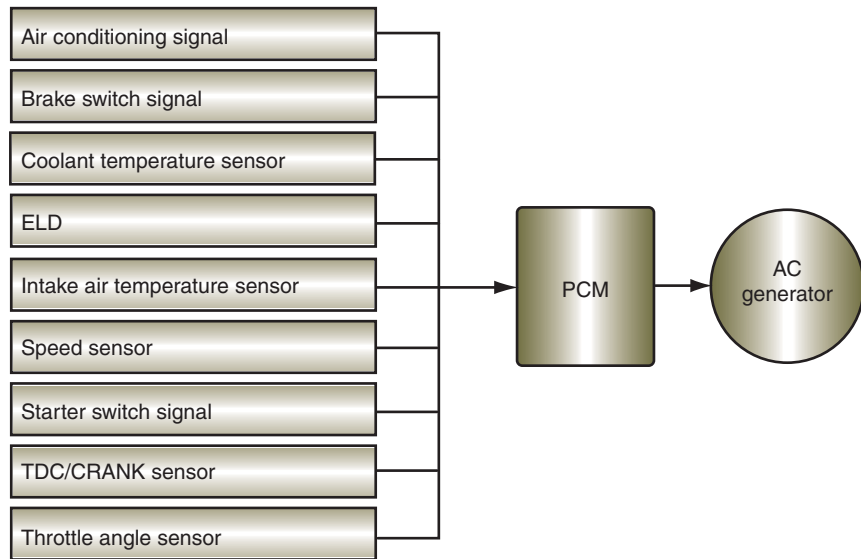
The PCM's decisions, concerning voltage regulation, are based on battery voltage and battery temperature. When the desired output voltage is obtained (based on battery temperature), the PCM switches the transistor on or off as needed. This transistor grounds the AC generator's field to control output voltage.

General Motors' CS series generators may be connected directly to the PCM through terminals L and F at the generator. The voltage regulator portion of the PCM switches the field current on and off at a frequency of about 400 times per second. Varying the on and off time of the field current controls the voltage output of the generator.

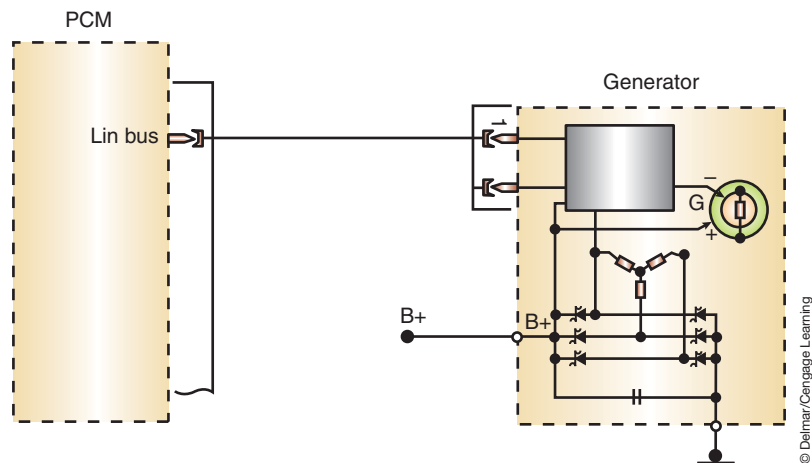
The computer-controlled regulation system has the ability to precisely maintain and control the changing rate according to the electrical requirements, battery (or ambient) temperature, and several other inputs (Figure 7-52).

Another generator control method is that like that used by Mercedes Benz (Figure 7-53). This system uses a generator that is actually a slave module on the LIN bus network. The PCM communicates power requirements over the LIN bus concerning voltage set point and a set point governing time to the generator. The LIN interface chip translates the request

When the generator is a slave, module on a bus network is often called an interfaced generator.



**FIGURE 7-52** The PCM will use various inputs to regulate AC generator output.



**FIGURE 7-53** A generator with internal microprocessor using a bus network for communications to the PCM.

and output control is achieved by the integrated electronics with driver stages and an 8-bit microprocessor. This is referred to a power on-demand and reduces fuel consumption since the generator field is turned on only when needed. This also reduces underhood noises.

## CHARGING INDICATORS

There are three basic methods of informing the driver of the charging system’s condition: indicator lamps, ammeter, and voltmeter.

**AUTHOR’S NOTE:** Greater detail concerning operation of indicator lamps and gauges, including computer controlled systems, is provided in Chapter 13.

### Indicator Light Operation

As discussed earlier, most indicator lamps operate on the basis of opposing voltages. If the AC generator output is less than battery voltage, there is an electrical potential difference in the lamp circuit and the lamp will light. If there is no stator output through the diode trio, then the lamp circuit is completed to ground through the rotor field and TR<sub>1</sub> (Figure 7-54).

On most systems, the warning lamp will be “proofed” when the ignition switch is in the RUN position before the engine starts. This indicates that the bulb and indicator circuit are operating properly. Proofing the bulb is accomplished because there is no stator output without the rotor turning.

### Ammeter Operation

In place of the indicator light, some manufacturers install an ammeter. The ammeter is wired in series between the AC generator and the battery (Figure 7-55). Most ammeters work on the principle of d’Arsonval movement.

The movement of the ammeter needle under different charging conditions is illustrated (Figure 7-56). If the charging system is operating properly, the ammeter needle will remain within the normal range. If the charging system is not generating sufficient current, the needle will swing toward the discharge side of the gauge. When the charging system is recharging

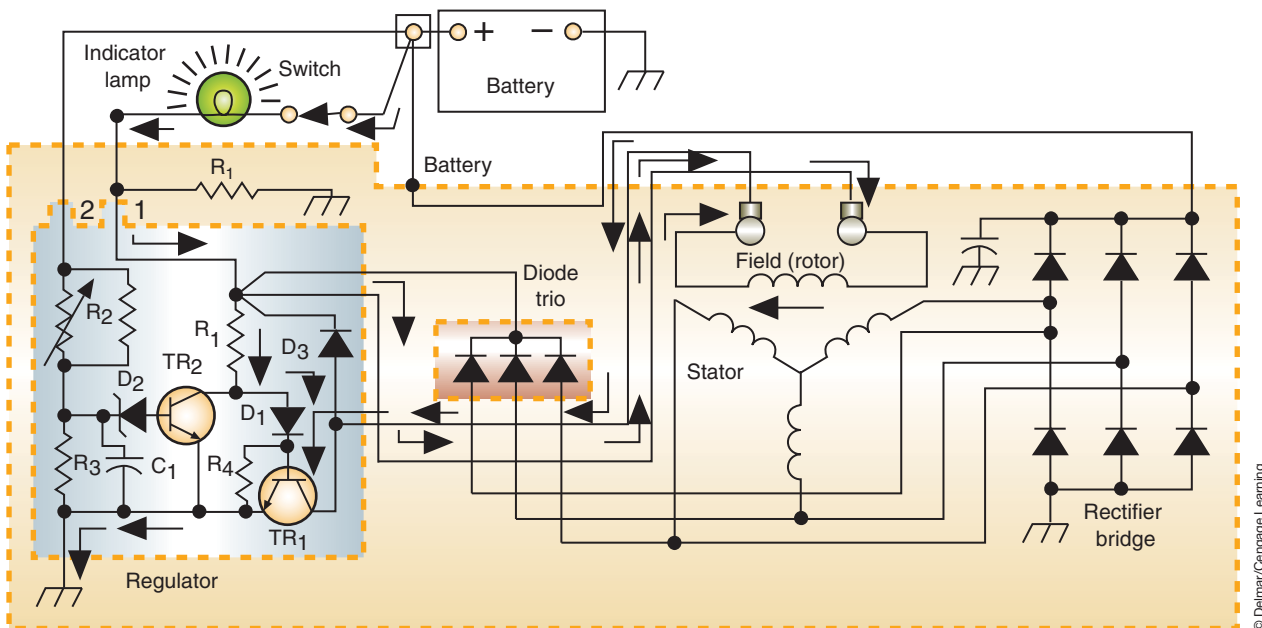
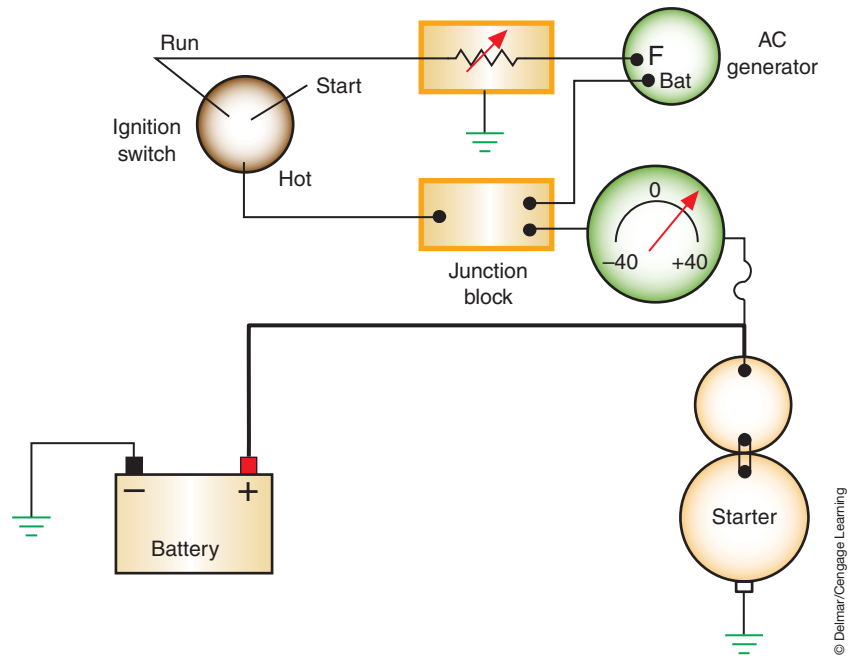


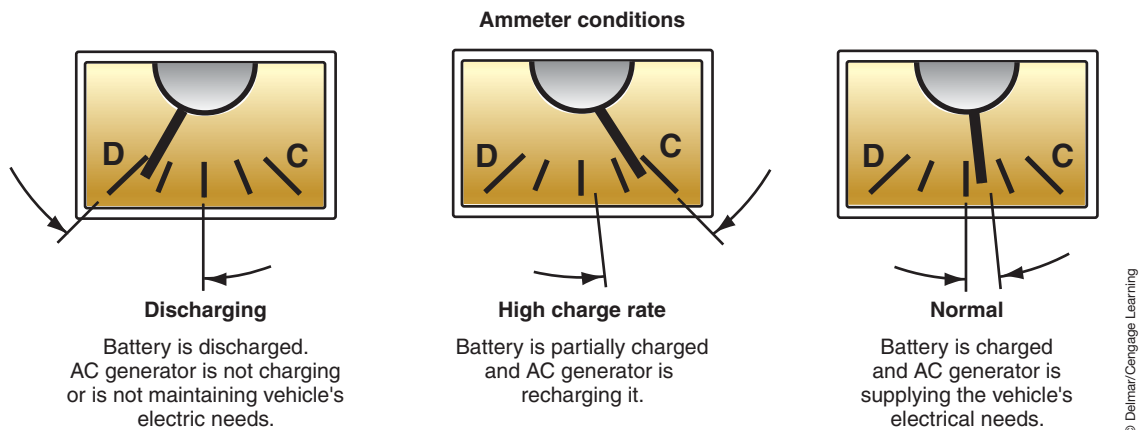
FIGURE 7-54 Electronic regulator with an indicator light on due to no AC generator output.

© Delmar/Cengage Learning





**FIGURE 7-55** Ammeter connected in series to indicate charging system operation.



**FIGURE 7-56** Ammeter needle movement indicates charging conditions.

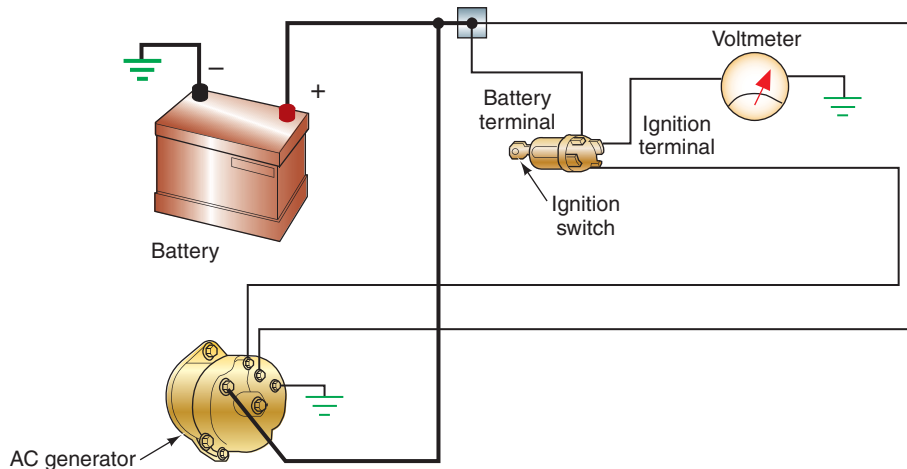
the battery, or is called on to supply high amounts of current, the needle deflects toward the charge side of the gauge.

It is normal for the gauge to read a high amount of current after initial engine startup. As the battery is recharged, the needle should move more toward the normal range.

## Voltmeter Operation

Because the ammeter is a complicated gauge for most people to understand, many manufacturers use a voltmeter to indicate charging system operation. In early systems, the voltmeter is connected between the battery positive and negative terminals (Figure 7-57).

When the engine is started, it is normal for the voltmeter to indicate a reading between 13.2 and 15.2 volts. If the voltmeter indicates a voltage level that is below 13.2, it may mean that the battery is discharging. If the voltmeter indicates a voltage reading that is above



**FIGURE 7-57** Voltmeter connected to the charging circuit to monitor operation.

15.2 volts, the charging system is overcharging the battery. The battery and electrical circuits can be damaged as a result of higher-than-normal charging system output.

In most modern systems, the voltmeter is controlled either directly by the PCM or by information sent to the instrument cluster by the PCM. A dedicated circuit from the battery to the PCM allows the PCM to constantly monitor the battery voltage.

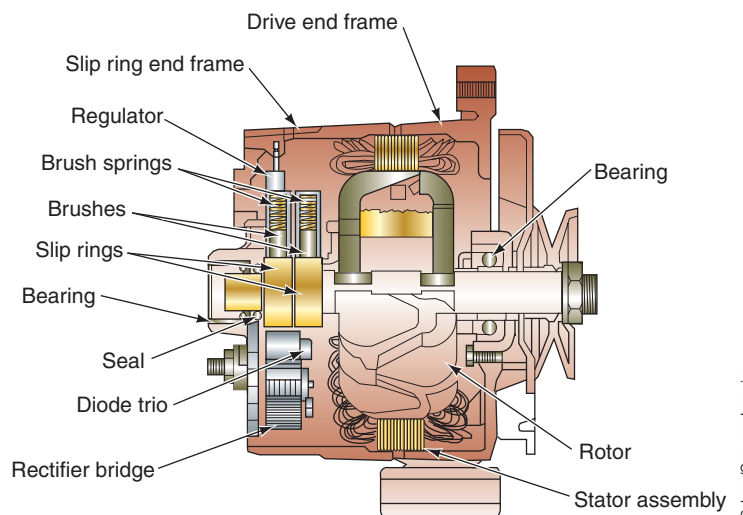
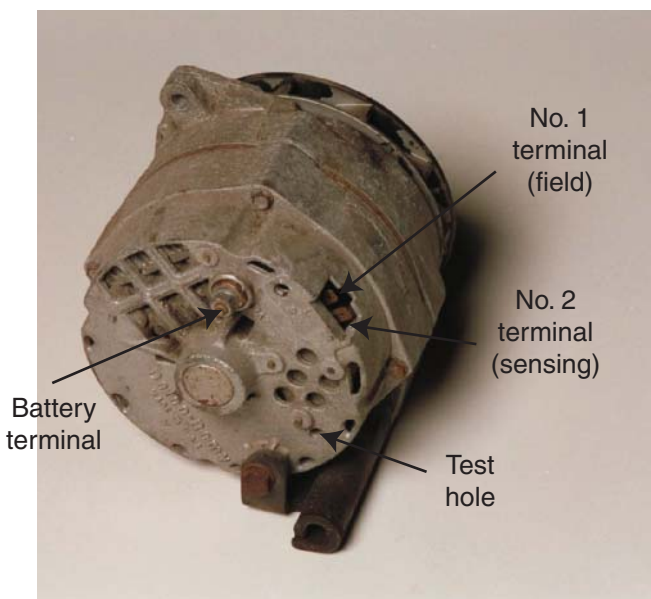
## AC GENERATOR DESIGN DIFFERENCES

Although all AC generators operate on the same principles, there are differences in the styles and construction.

### General Motors 10SI Series

SI series AC generators use an internal voltage regulator that is mounted to the inside of the slip ring end frame (Figure 7-58). There are three terminals on the rear-end frame of the AC generators:

**Shop Manual**  
Chapter 7, page 277



**FIGURE 7-58** 10SI AC generator.

- **Terminal number 1:** Connects to the field through one brush and slip ring and to the output of the diode trio. In addition, this terminal is connected to a portion of the regulator and warning light circuitry.
- **Terminal number 2:** Connects to the regulator to supply battery voltage to a portion of the regulator circuitry that senses system voltage.
- **BAT terminal:** Connects to the output of the stator windings and supplies the battery with charging voltage.

Most SI series AC generators use a 14-pole rotor. Depending on model, the stator is wired either in wye or delta fashion. Models 10 and 12 use the wye connection. All other models use the delta connection.

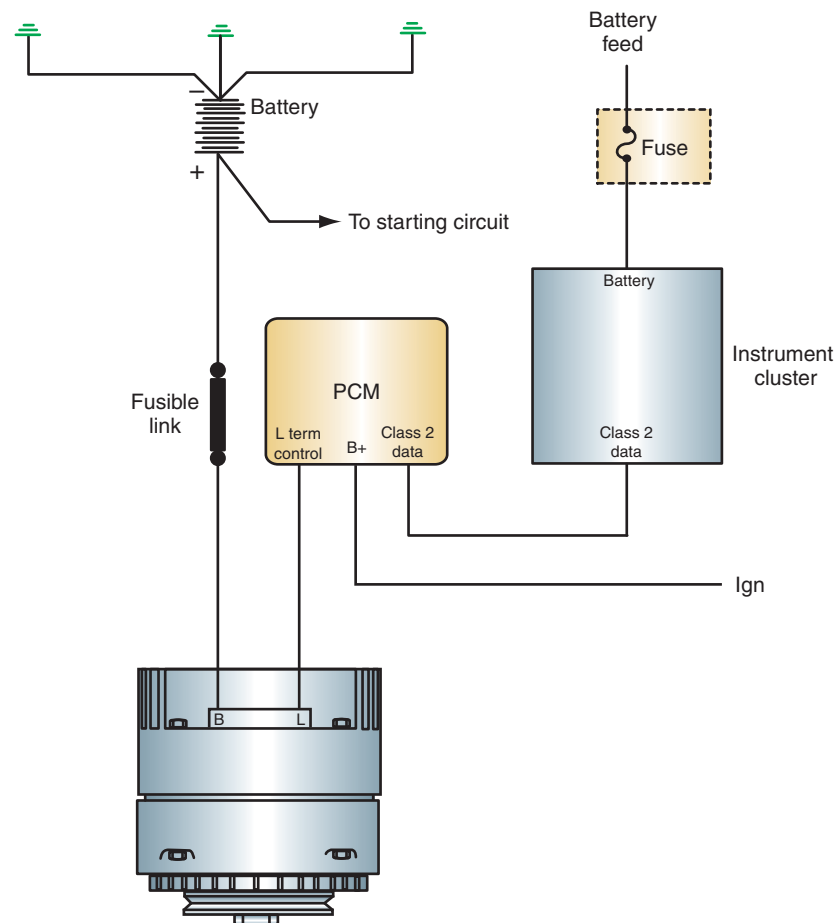
**Shop Manual**  
Chapter 7, page 277

The series designation number refers to the diameter of the outer stator lamination in millimeters.

## General Motors CS Series

Beginning in 1986 and continuing through the 1999 model year, General Motors used the smaller CS series AC generator with an internal regulator. This generator uses a delta wound stator. The field current is supplied directly from the stator, thus eliminating the need for a diode trio. The generators in this series include the CS-121, CS-130, and CS-144, which represent the unit size in millimeters.

As mentioned earlier, recent CS series generators use computer control regulation of the AC generator. In addition to regulation control by varying the ground of the field windings, General Motors also uses a system of pulsing the voltage output to the field windings from the PCM (Figure 7-59). This type of generator has a constant field winding ground connection.



**FIGURE 7-59** General Motors' PCM-controlled charging system using high side pulse width control.

© Delmar/Cengage Learning

## AD200 Series AC Generators

Beginning in 1999, General Motors began to change to a Delphi-designed AD200 series generator (Figure 7-60). The AD200 designation refers to second-generation (200), air-cooled (A) and dual internal fans (D). There are three AD200 series models being used, depending on unit diameters: AD230 (130 mm), AD237 (137 mm), and AD244 (144 mm). Amperage output of these alternators ranges from 102 amps to 150 amps. The AD200 series generator uses an offset-wound stator to achieve a more consistent output voltage. Some models also use a pulley with a built-in clutch. The rectifier design has an increased surface area and uses avalanche diodes.

## Ford AC Generators

Ford has used several different designs of AC generators. For many years, Ford used the common rear- or side-terminal AC generator. The rear-terminal AC generators used two different types of rectifiers. One rectifier had a single plate that contained all six of the diodes (Figure 7-61).

The second type of rectifier used two plates that were stacked on top of each other. One plate contained the positive diodes and the other contained the negative diodes.

**Shop Manual**  
Chapter 7, pages  
274, 278

The single-plate rectifier is called a flat rectifier.



FIGURE 7-60 AD200 series generator.

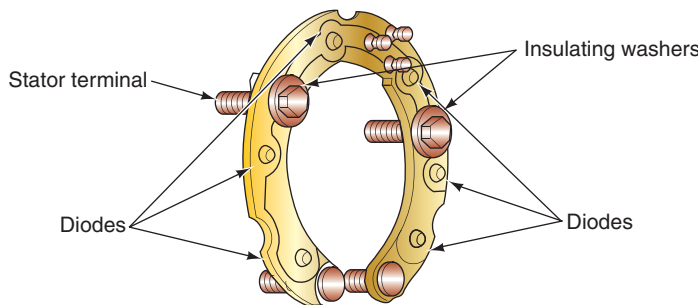


FIGURE 7-61 Flat-type rectifier has single plate containing all six diodes.

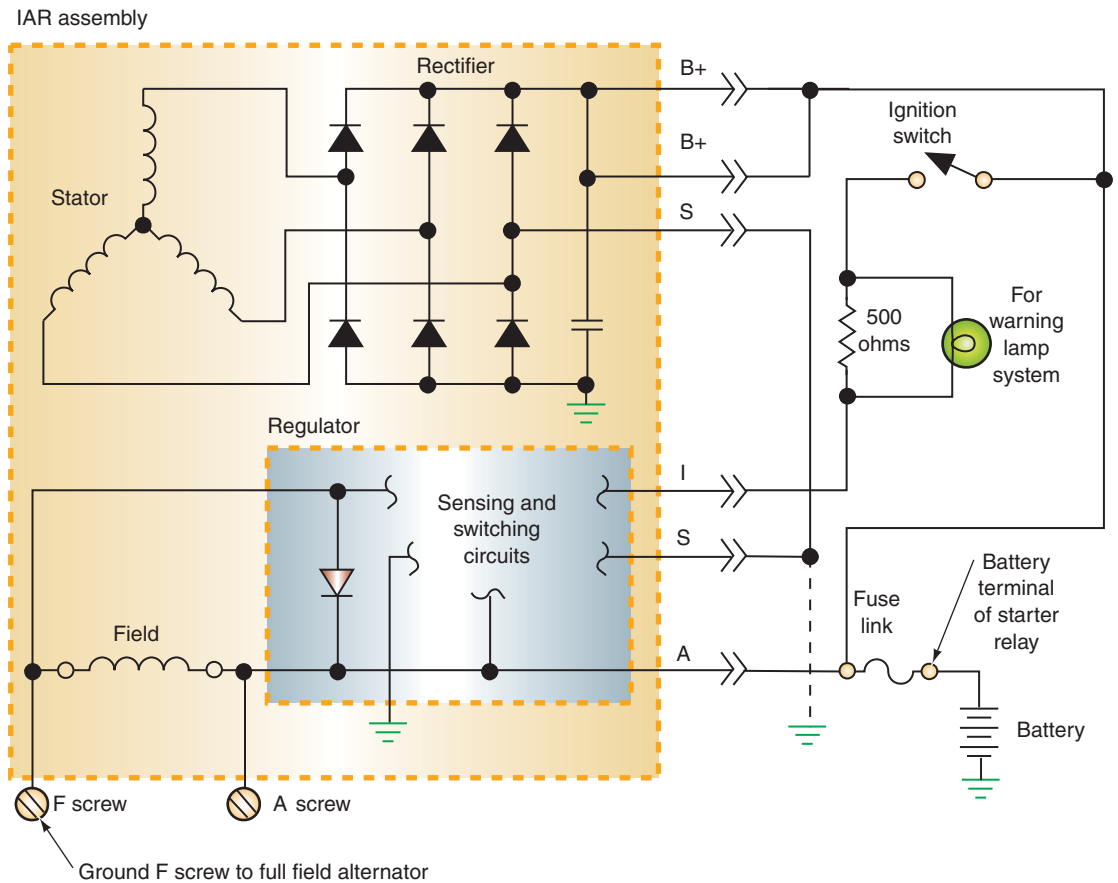


FIGURE 7-62 IAR charging system schematic.

The two-plate rectifier is called a stacked rectifier.

On the rear-terminal AC generators there were four terminals on the end frame:

- **BAT terminal:** Stator output connection to the battery.
- **FLD terminal:** Connection to one side of the field winding through the insulated brush and the slip ring.
- **STA terminal:** Connection to the neutral stator junction.
- **GRD terminal:** Connection for the ground wire from the regulator.

The Ford side terminal AC generator is larger and has higher output capacities. The same four terminals are used; however, they are arranged differently.

In 1984, Ford introduced an integral alternator regulator (IAR) AC generator. The regulator is mounted on the exterior of the rear-end frame, which simplifies testing and replacement of the regulator. The F and A terminals are used to test the charging system. Additional modifications include the brushes being a part of the regulator.

When the ignition switch is in the RUN position, voltage is sent to the I terminal of the regulator (Figure 7-62). Regulator terminal A senses system voltage. Field current is drawn through this terminal also.

Ford's EVR charging system uses a solid-state external regulator. This style is built with either rear or side terminals. The side-terminal design provides higher output by using delta wound stators.

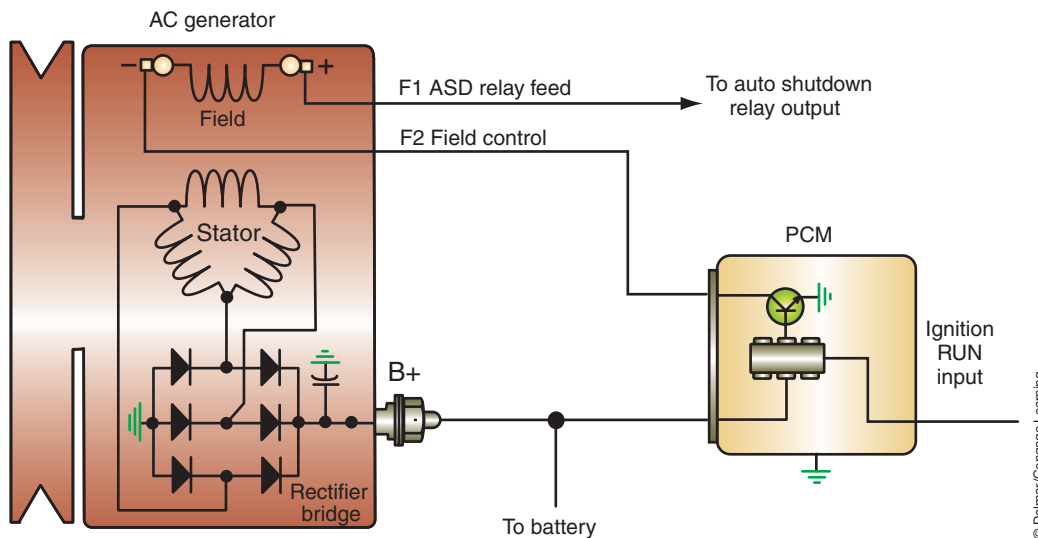
EVR stands for external voltage regulator.

## Chrysler AC Generators

Early Chrysler AC generators used separate heat sinks for the positive and negative diodes. Both heat sinks are attached to the rear-end frame. Also, the brushes are attached to the exterior of the end frame. This allows for brush replacement without having to disassemble the

Shop Manual

Chapter 7, page 280



**FIGURE 7-63** Computer-controlled dual-output charging system.

AC generator (in fact, the brushes can usually be replaced without having to remove the AC generator from the vehicle).

The three terminals on the rear-end frame are connected as follows:

- **BAT terminal:** Connects the stator output to the battery to supply charging voltage.
- **FLD terminal:** There are two field terminals. Battery voltage is applied to one of the field terminals; the regulator connects to the second field terminal.

In 1985, Chrysler introduced a delta wound, dual-output, computer-controlled charging system (Figure 7-63). This system has some unique capabilities:

1. The system is capable of varying charging system output based on the ambient temperature and the system's voltage needs.
2. The computer monitors the charging system and is capable of self-diagnosis.

When the ignition switch is in the RUN position, the PCM checks the ambient temperature and determines required field current. Based on inputs relating to temperature and system requirements, the PCM determines when current output adjustments are required.

In recent years, Chrysler used a Nipponclenso or Bosch-built AC generator that has a wye wound stator. This system also uses a PCM, to control voltage regulation by varying the field winding ground. Vehicles equipped with next-generation controllers (NGC) have high side control, similar to that of General Motors CS series discussed earlier.

## Mitsubishi AC Generators

Some Mitsubishi AC generators use an internal voltage regulator (Figure 7-64). It also has two separate wye connected stator windings (Figure 7-65). Each of the stator windings has its own set of six diodes for rectification.

This AC generator also uses a diode trio to rectify stator voltage to be used in the field winding. The three terminals are connected as follows:

- **B terminal:** Connects the output of both stator windings to the battery, supplying charging voltage.
- **R terminal:** Supplies 12 volts to the regulator.
- **L terminal:** Connects to the output of the diode trio to provide rectified stator voltage to designated circuits.

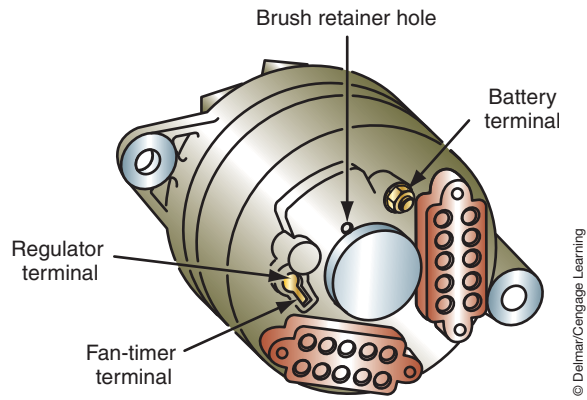
Another method that Mitsubishi uses for charging control involves a single wye wound stator generator with an internal regulator that interfaces with the PCM (Figure 7-66). The



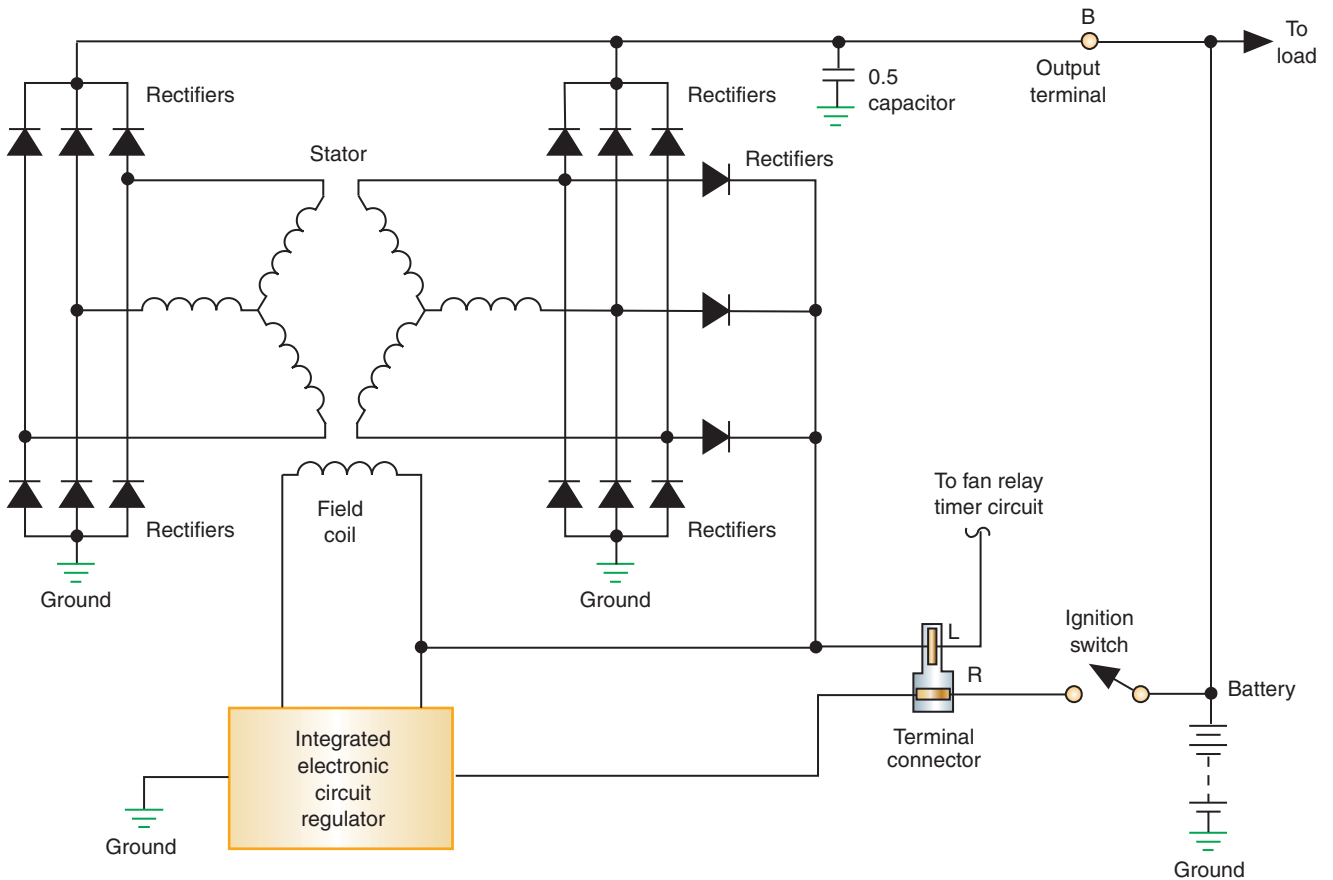
## A BIT OF HISTORY

Chrysler equipped its vehicles with AC generators in the late 1950s, making it the first manufacturer to use an AC generator. Chrysler introduced the dual-output AC generator (40 or 90 amperes) with computer control in 1985.



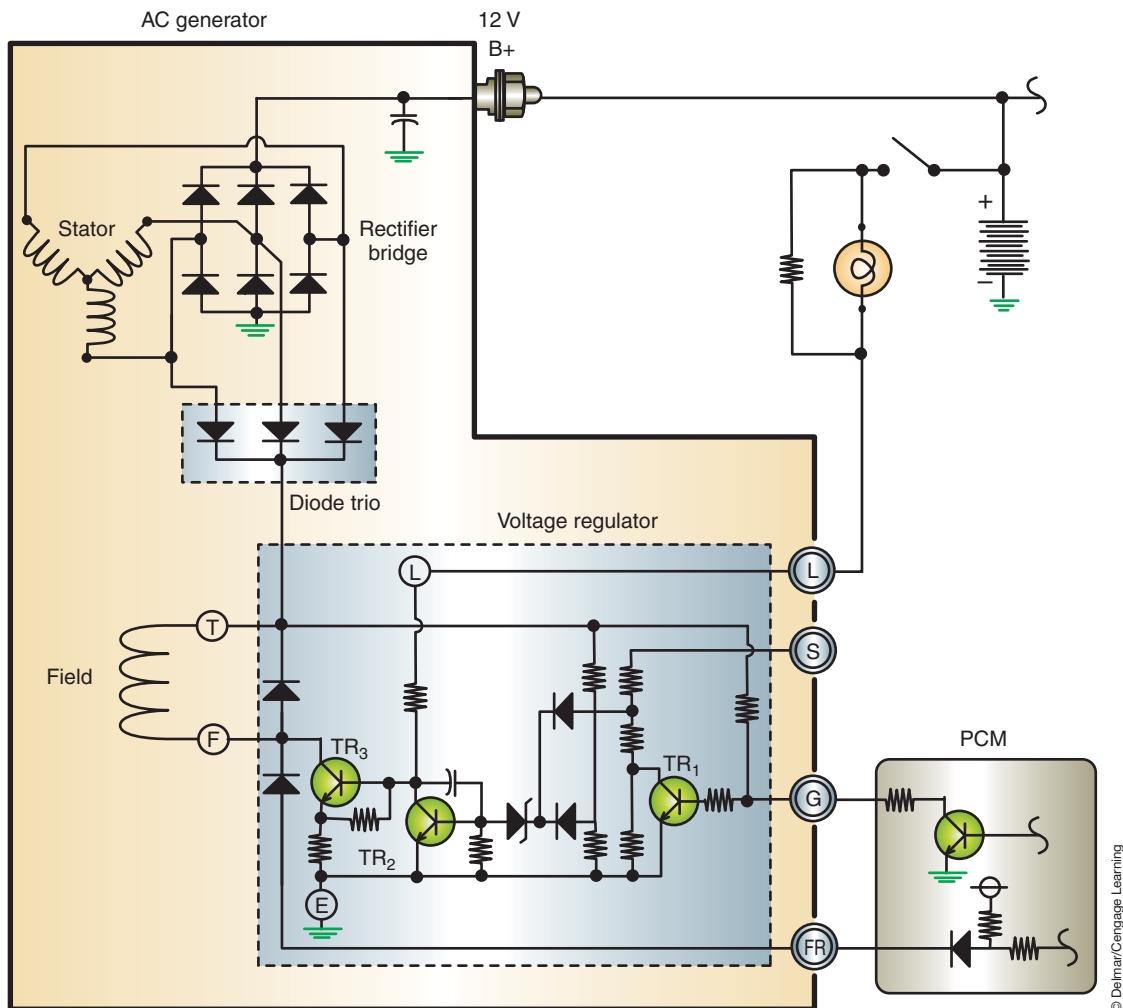


**FIGURE 7-64** Mitsubishi AC generator terminals.



**FIGURE 7-65** The Mitsubishi AC generator uses two separate stator windings and a total of 15 diodes.

PCM monitors the state of the field coil through terminal FR of the generator. The PCM sends 5 volts to the FR terminal. As the field coil is turned on and off by the internal regulator, the voltage will cycle between 5 and 0 volts. When the PCM senses 5 volts, it knows the field coil is turned off, and when the voltage drops close to 0 volts, it knows the field coil is turned on. This allows the PCM to control idle speed when the regulator is applying full field. In addition, the PCM can dampen the effects of full fielding during high electrical loads. This will prevent occurrences such as lights flicking bright and dim as the field coil is turned on and off.



**FIGURE 7-66** Schematic of Mitsubishi charging system using both an internal voltage regulator and the PCM to control output.

© Delmar/Cengage Learning

When a full field condition is sensed by the PCM, it will modulate its internal transistor. This will then control the power transistor in the internal regulator. The PCM has a maximum authority of 14.4 volts. If the charging system output exceeds this level, the internal regulator turns the power transistor off.

To perform this function, the PCM will duty cycle its internal transistor, which turns the TR<sub>1</sub> in the generator on and off. In Figure 7-66, battery voltage is applied to the S terminal of the generator. This voltage goes through three resistors in series to ground (Figure 7-67). Each of the resistors has 2 ohms of resistance. If the PCM internal transistor is turned on, the voltage to the base of TR<sub>1</sub> is pulled low and TR<sub>1</sub> is turned off. With TR<sub>1</sub> turned off, all three of the resistors are involved in the circuit. Each resistor will drop 4 volts. Since R<sub>1</sub> drops 4 volts, 8 volts is applied to the zener diode. This is enough to blow through the diode, applying voltage to the base of TR<sub>2</sub> and turning it on. With TR<sub>2</sub> turned on, base voltage to transistor TR<sub>3</sub> is pulled low and transistor TR<sub>3</sub> will be turned off. With TR<sub>3</sub> turned off, the field coil is de-energized.

If the internal transistor in the PCM is turned off, battery voltage will be applied to the base of TR<sub>1</sub> and turn it on. TR<sub>1</sub> will now supply an alternate path to ground, bypassing R<sub>3</sub>. Now, only R<sub>1</sub> and R<sub>2</sub> are in series and each resistor will drop 6 volts. This means that 6 volts

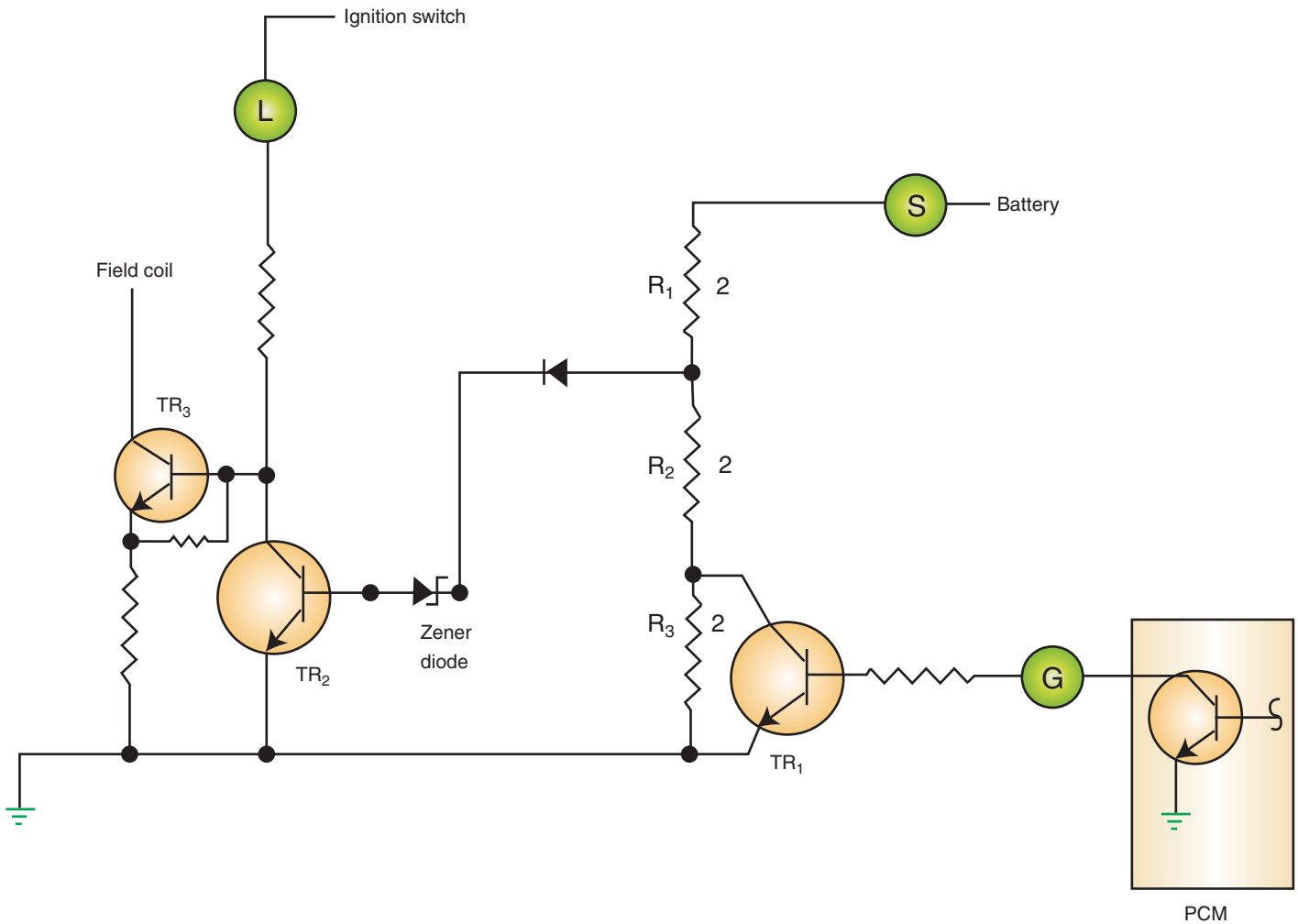


FIGURE 7-67 Three resistors in series on the sense circuit.

will be applied to the zener diode. This is not enough to blow through the zener; therefore,  $TR_2$  will be off. With  $TR_2$  off, battery voltage is applied to the base of transistor  $TR_3$  and it will be turned on. Since transistor  $TR_3$  is on, the field coil circuit to ground is complete and the coil is energized. The PCM internal transistor switches on and off several times a second to prevent the generator from going to full field too rapidly.

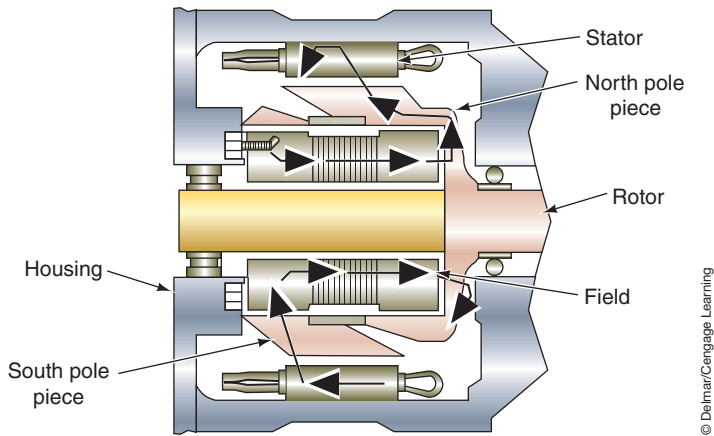
## Brushless AC Generators

Brushless AC generators are normally used in heavy-duty trucks.

Some manufacturers have developed AC generators that do not require the use of brushes or slip rings. In these AC generators, the field winding and the stator winding are stationary (Figure 7-68). A screw terminal is used to make the electrical connection. The rotor contains the pole pieces and is fitted between the field winding and the stator winding.

The magnetic field is produced when current is applied to the field winding. The air gaps in the magnetic path contain a nonmetallic ring to divert the lines of force into the stator winding.

The pole pieces on the rotor concentrate the magnetic field into alternating north and south poles. When the rotor is spinning, the north and south poles alternate as they pass the stator winding. The moving magnetic field produces an electrical current in the stator winding. The alternating current is rectified in the same manner as in conventional AC generators.



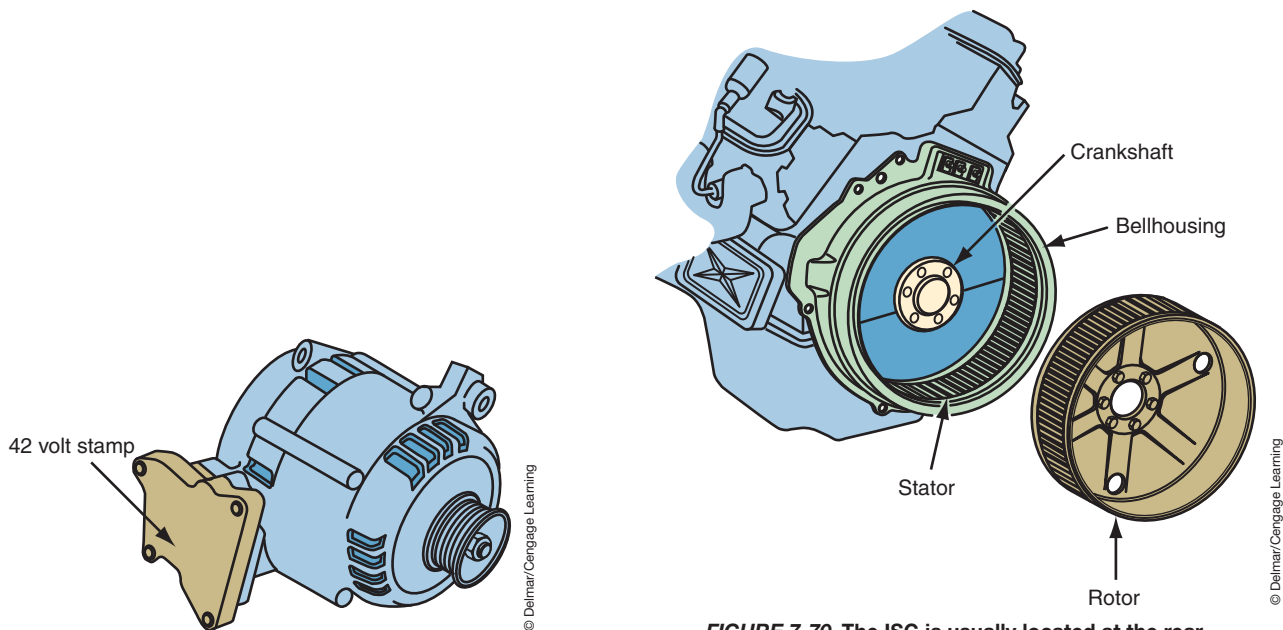
**FIGURE 7-68** Brushless AC generator with stationary field and stator windings.

## HEV CHARGING SYSTEMS

As was discussed in Chapter 6, HEVs utilize the automatic stop/start feature to shut off the engine whenever the vehicle is not moving or when power from the engine is not required. Some HEV systems use a starter/generator unit to perform both functions. The difference between a motor and a generator is the motor uses two opposing magnetic fields and the generator uses one magnetic field that has rotating conductors. The use of electronics to control the direction of current flow allows the unit to function as both a motor and a generator.

There are two basic designs of the starter/generator. The first design uses a belt alternator starter (BAS) that is about the same size as a conventional generator and is mounted in the same way (Figure 7-69). The second design is to mount an integrated starter/generator (ISG) at either end of the crankshaft. Most designs have the ISG mounted at the rear of the crankshaft between the engine and transmission (Figure 7-70).

The ISG is a 3-phase AC motor that can provide power and torque to the vehicle. It also supports the engine, when the driver demands more power. As seen in Figure 7-70, the ISG includes a rotor and stator that is located inside the transmission bell housing. The stator is attached to the engine block and is made up of two separate lamination stacks. The rotor is bolted to the engine crankshaft and has both wire wound and permanent magnet sections.



**FIGURE 7-69** A BAS used on some HEVs.

**FIGURE 7-70** The ISG is usually located at the rear of the crankshaft in the bell housing.

Rectification is accomplished with traditional diodes. The advantage of this rotor and stator design is that the output at engine idle speed is up to 240 amps. Maximum output can exceed 300 amps.

Generation is done anytime the engine is running. Since the rotor is connected to the crankshaft, it turns at the speed of the engine. Also, during vehicle deceleration the ISG regenerates the power that is used to slow the vehicle to recharge the HV and auxiliary batteries. When the vehicle is traveling downhill and there is zero load on the engine, the wheels can transfer energy through the transmission and engine to the ISG. The energy (AC voltage) is converted to DC voltage and sent to the batteries for storage and use by the electrical components of the vehicle.

Remember that the output of conventional AC generators is dependent upon the intensity of the magnetic field, the number of conductors passing through the magnetic field at any given time, the number of magnets, and the speed at which the lines of flux or the conductors are moving when the intercept occurs. Since the speed at which the magnetic poles move influences the amount of current output, then output will be the lowest at idle. Maximum output will not be achieved until higher engine speeds. It is during the times of low engine speeds that current demand is likely to be at its highest. To increase output, the hybrid rotor has permanent magnets located between the pole pieces of the rotor. The magnet flux from these permanent magnets goes into the pole piece, through the rotor shaft, and then back through the pole piece on the opposite side of the magnet. The permanent magnet fills the gap between the pole pieces, forcing more of the flux from the rotor into the stator windings. This results in an increase of the alternator's output.

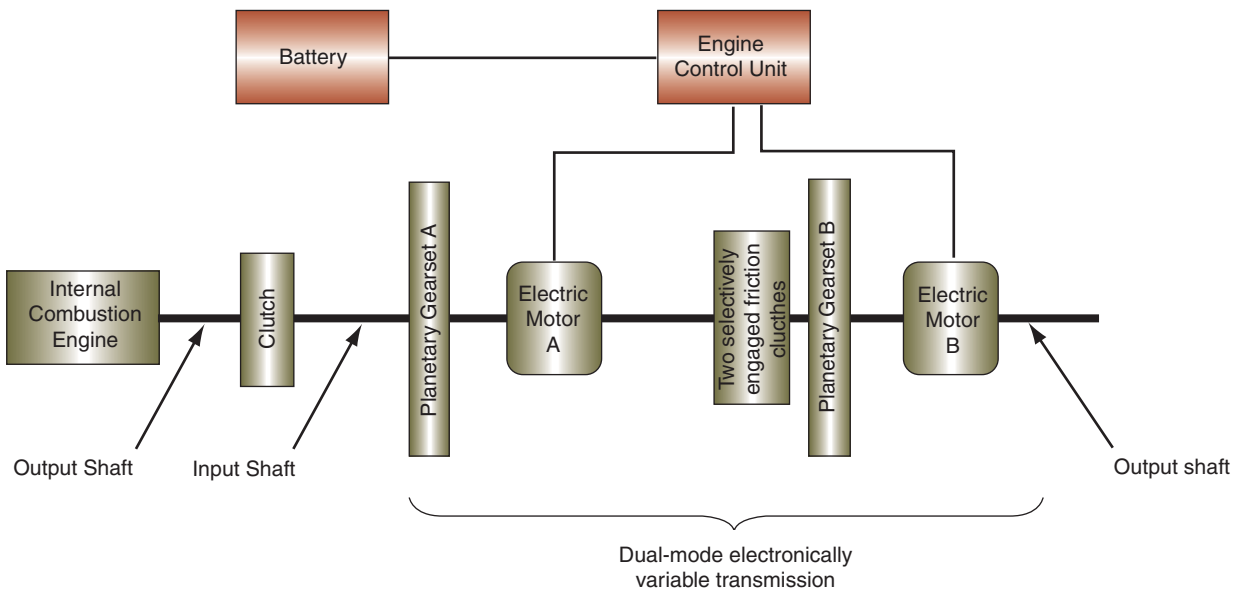
Regulation uses a technique that is referred to as "boost-buck." At low speed and high electrical loads, the wire wound section is fully energized. This extra magnetic flux then boosts the output of the permanent magnet section. When the engine is operated at a medium speed and with a medium electrical load, the field current is off. During this time only the permanent magnet section is producing the output. During high-speed, low-electrical-load conditions, the field current is reversed. This bucks the permanent magnet's field and maintains a constant output voltage.

Full hybrid vehicles that are capable of propelling the vehicle in an electric only mode require HV batteries to power the three-phase AC motors. These batteries may have a capacity of over 300 volts. Many full hybrid vehicles have at least two AC motors located in the transmission or transaxle assembly to operate the planetary gear sets that provide constantly variable gear ratios (Figure 7-71). These motors can also be used as generators. If the HV battery SOC becomes too low, the engine is started and the crankshaft drives motor "A" to generate high voltage AC current. The current is rectified to DC voltage and sent to recharge the HV battery. Voltage generation can also occur whenever one of the motors slips. In most cases one of the motors is slipping at all times. The slipping causes a cutting of the magnetic field and results in AC current. This current is used to supply electrical energy to the other motor (Figure 7-72).

## Regenerative Braking

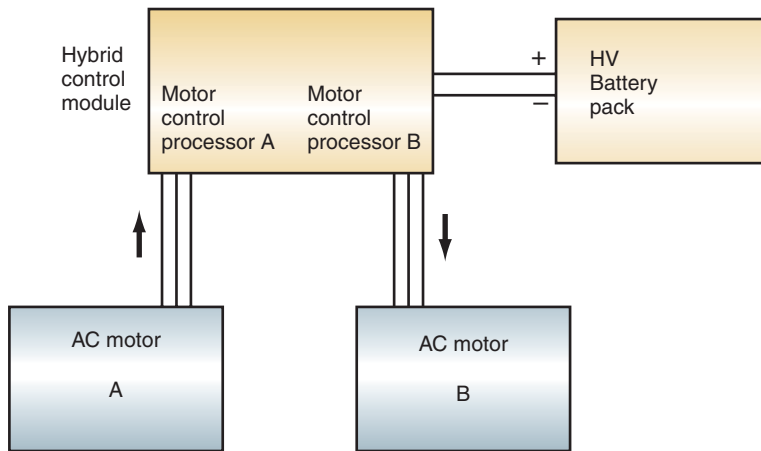
About 30% of the kinetic energy lost during braking is in heat. When decreasing acceleration, regenerative braking helps to minimize energy loss by recovering the energy used to slow the vehicle. This is done by converting rotational energy into electrical energy through the ISG or AC motors. Regenerative braking assumes some of the stopping duties from the conventional friction brakes and uses the electric motor to help slow the vehicle. To do this, the electric motor operates as a generator when the brakes are applied, recovering some of the kinetic energy and converting it into electrical energy. The motor becomes a generator by using the kinetic energy of the vehicle to store power in the battery for later use.

### GM Two-Mode Hybrid Electric Powertrain



© Delmar/Cengage Learning

**FIGURE 7-71** Multiple motors are usually used in a full hybrid.



© Delmar/Cengage Learning

**FIGURE 7-72** Current generated in one motor can be used to power the other.

When regenerative braking operation is taking place, no friction braking is occurring. Regenerative braking is mainly a function of light brake pedal application, using inputs from the various sensors such as the pedal angle sensor, the vacuum sensor, and the accelerator pedal position sensor. As soon as the accelerator pedal is released, the hybrid control module will initiate regenerative braking. At this point, the electric motors are being turned by the wheels, and act as generators to recharge the HV battery since the rotor is turning within the stator windings. The hydraulic brakes are not used during this phase. If additional vehicle deceleration is required, the hybrid controller can increase the force required to turn the electric motors. This increases resistance to wheel rotation that helps further slow the vehicle. In cases where more braking power is needed, hydraulic brakes are used.



## DC/DC Converter

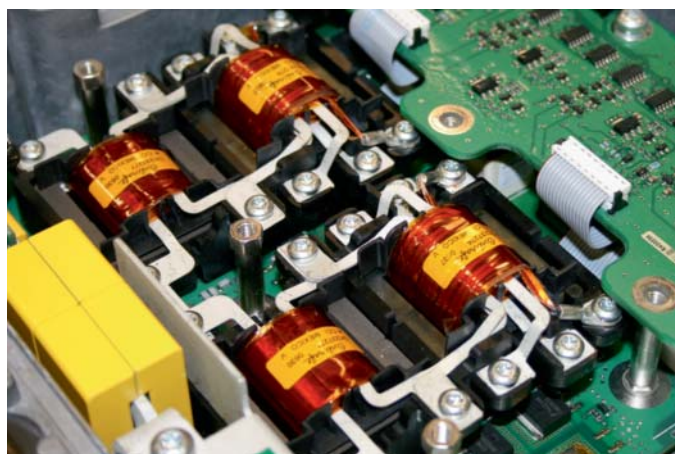
The AC voltage from the motors during regenerative or charging modes is rectified by the inverter module. Since this module converts the high AC voltage into high DC voltage to recharge the HV battery, it cannot be used to recharge the auxiliary battery. An additional function of the inverter is that of a DC/DC converter. The converter allows the conversion of electrical power between the HV direct current system and the low voltage (LV) direct current system. The converter is a bi-directional, solid state, DC conversion device that charges the 12-volt system from the 300-volt direct current system. The converter replaces the function of the engine driven generator while maintaining isolation of the HV system.

The conversion of HV to LV voltage is accomplished through magnetic fields instead of physical wired connections. Sets of coils are used to accomplish the voltage conversion (Figure 7-73). The coils operate as step down transformers to reduce the high DC voltage to the low DC voltage. By sequentially inducing and collapsing the magnetic field of the coils, a smooth output on the 12-volt side is maintained.

As discussed in Chapter 5, when the HEV is placed into the jump assist mode, the converter is required to charge the 300-volt system by use of the 12 volt battery. In this mode, the coils operate as step-up transformers to increase the 12 volts to the 300 volts required to charge the HV battery.

**AUTHOR'S NOTE:** When there is a high rate of current conversion taking place in the inverter/converter module, a significant amount of heat is produced. Many manufacturers will use a separate cooling system to run coolant through these modules to prevent damage from the heat.

The inverter is PWM controlled by the hybrid control module or by bus communication from the control module. The hybrid control module requests the required amount of voltage to be applied to the LV system. This will normally be a commanded PWM to the converter that is between 33% and 90%. In this range, the converter increases or decreases the charging voltage between 12.5 and 15.5 volts. In the event that the signal is lost from the control module (or the signal is corrupted in any way), the default low voltage setting is at 13.8 volts.



**FIGURE 7-73** DC/DC converter coils are used as transformers to reduce the 300 DC volts to about 14 DC volts.

## SUMMARY

---

- The most common method of stator connection is called the wye connection. In the wye connection, one lead from each winding is connected to one common junction. From this junction, the other leads branch out in a Y pattern.
- Another method of stator connection is called the delta connection. The delta connection connects the lead of one end of the winding to the lead at the other end of the next winding.
- The diode rectifier bridge provides reasonably constant DC voltage to the vehicle's electrical system and battery. The diode rectifier bridge is used to change the current in an AC generator.
- The converting of AC current to DC current is called rectification.
- The three principal circuits used in the AC generator are the charging circuit, which consists of the stator windings and rectifier circuits; the excitation circuit, which consists of the rotor field coil and the electrical connections to the coil; and the preexcitation circuit, which supplies the initial current for the field coil that starts the buildup of the magnetic field.
- The voltage regulator controls the output voltage of the AC generator, based on charging system demands, by controlling field current. The higher the field current, the higher the output voltage.
- The regulator must have system voltage as an input in order to regulate the output voltage. The input voltage to the regulator is called sensing voltage.
- Because ambient temperatures influence the rate of charge that a battery can accept, regulators are temperature compensated.
- The A circuit is called an external grounded field circuit and is always an electronic-type regulator. In the A circuit, the regulator is on the ground side of the field coil. The B+ for the field coil is picked up from inside the AC generator.
- Usually the B circuit regulator is mounted externally of the AC generator. The B circuit is an internally grounded circuit. In the B circuit, the voltage regulator controls the power side of the field circuit.
- Isolated field AC generators pick up B+ and ground externally. The AC generator has two field wires attached to the outside of the case. The voltage regulator can be located either on the ground (A circuit) or on the B+ (B circuit) side.
- An electronic regulator uses solid-state circuitry to perform the regulatory functions using a zener diode that blocks current flow until a specific voltage is obtained, at which point it allows the current to flow.
- On most modern vehicles, the regulator function has been incorporated into the vehicle's engine computer. Regulation of the field circuit is through the ground (A circuit).
- There are three basic methods of informing the driver of the charging system's condition: indicator lamps, ammeter, and voltmeter.
- Most indicator lamps operate on the basis of voltage drop. If the charging system output is less than battery voltage, there is an electrical potential difference in the lamp circuit and the lamp will light.
- The ammeter measures charging and discharging current in amperes. The ammeter is wired in series between the AC generator and the battery.
- The voltmeter is usually connected between the battery's positive and negative terminals.
- The hybrid AC generator design consists of a rotor assembly with both wire wound and permanent magnet sections. The permanent magnets are located between the pole pieces of the rotor.
- The IGS is a three-phase AC motor that can provide power and torque to the vehicle that can also generate voltage whenever the rotor is turning.

## TERMS TO KNOW

delta connection  
diode rectifier bridge  
diode trio  
electronic regulator  
EVR  
Full-wave rectification  
half-wave rectification  
heat sink  
inductive reactance  
Pulse width modulation  
rectification  
rotor  
sensing voltage  
slip rings  
stator  
wye wound connection

## SUMMARY

- Generation is done anytime the engine is running.
- During vehicle deceleration the ISG regenerates the power that is used to slow the vehicle to recharge the HV and auxiliary batteries.
- The AC motors used in full hybrid vehicles can be used as generators whenever the engine is running and during vehicle deceleration.
- Generation can also occur whenever one of the motors slips. The slipping causes a cutting of the magnetic field and results in AC current. This current is used to supply electrical energy to the other motor.
- During vehicle coast conditions the electric motors are being turned by the wheels, and act as generators to recharge the HV battery. If additional vehicle deceleration is required, the hybrid controller can increase the force required to turn the electric motors.
- The AC voltage from the motors during regenerative or charging modes is rectified by the inverter module. Since this module converts the high AC voltage into high DC voltage to recharge the HV battery.
- The DC/DC converter allows the conversion of electrical power between the HV system and the low voltage (LV) system and replaces the function of the engine driven generator while maintaining isolation of the HV system.

## REVIEW QUESTIONS

### Short-Answer Essays

1. List the major components of the charging system.
  2. List and explain the function of the major components of the AC generator.
  3. What is the relationship between field current and AC generator output?
  4. Identify the differences between A, B, and isolated circuits.
  5. Explain the operation of charge indicator lamps.
  6. Describe the two styles of stators.
  7. What is the difference between half-wave and full-wave rectification?
  8. Describe how AC voltage is rectified to DC voltage in the AC generator.
  9. What is the purpose of the charging system?
  10. Explain the meaning of regenerative braking.
2. All charging systems use the principle of \_\_\_\_\_ to generate the electrical power.
  3. The \_\_\_\_\_ creates the rotating magnetic field of the AC generator.
  4. \_\_\_\_\_ are electrically conductive sliding contacts, usually made of copper and carbon.
  5. In the \_\_\_\_\_ connection stator, one lead from each winding is connected to one common junction.
  6. The \_\_\_\_\_ controls the output voltage of the AC generator, based on charging system demands, by controlling \_\_\_\_\_ current.
  7. In an electronic regulator, \_\_\_\_\_ controls AC generator output by varying the amount of time the field coil is energized.
  8. Full-wave rectification in the AC generator requires \_\_\_\_\_ pair of diodes.
  9. The \_\_\_\_\_ is the stationary coil that produces current in the AC generator.
  10. \_\_\_\_\_ recovers the heat energy used to brake by converting rotational energy into \_\_\_\_\_ energy through a system of electric motors and generators.

### Fill in the Blanks

1. The charging system converts the \_\_\_\_\_ energy of the engine into \_\_\_\_\_ energy to recharge the battery and run the electrical accessories.

## MULTIPLE CHOICE

---

- The magnetic field current of the AC generator is carried in the:  
A. Rotor.            C. Rectifier bridge.  
B. Diode trio.       D. Stator.
- The voltage induced in one conductor by one revolution of the rotor is called:  
A. Three-phase.    C. Single-phase.  
B. Half-wave.       D. Full-wave.
- Rectification is being discussed.  
*Technician A* says the AC generator uses a segmented commutator to rectify AC current.  
*Technician B* says the DC generator uses a pair of diodes to rectify AC current.  
Who is correct?  
A. A only            C. Both A and B  
B. B only            D. Neither A nor B
- Rotor construction is being discussed.  
*Technician A* says the poles will take on the polarity of the side of the coil that they touch.  
*Technician B* says the magnetic flux lines will move in opposite directions between adjacent poles.  
Who is correct?  
A. A only            C. Both A and B  
B. B only            D. Neither A nor B
- The amount of voltage output of the AC generator is related to:  
A. Field strength.  
B. Stator speed.  
C. Number of rotor segments.  
D. All of the above.
- The delta wound stator:  
A. Shares a common connection point.  
B. Has each winding connected in series.  
C. Does not require rectification.  
D. None of the above.
- Indicator lamp operation is being discussed.  
*Technician A* says in a system with an electronic regulator, the lamp will light if there is no stator output through the diode trio.  
*Technician B* says when there is stator output, the lamp circuit has voltage applied to both sides and the lamp will not light.  
Who is correct?  
A. A only            C. Both A and B  
B. B only            D. Neither A nor B
- Technician A* says only two stator windings apply voltage because the third winding is always connected to diodes that are reverse-biased.  
*Technician B* says AC generators that use half-wave rectification are the most efficient.  
Who is correct?  
A. A only            C. Both A and B  
B. B only            D. Neither A nor B
- Charging system regulation is being discussed.  
*Technician A* says the regulation of voltage is done by varying the amount of field current flowing through the rotor.  
*Technician B* says control of field current can be done either by regulating the resistance in series with the field coil or by turning the field circuit on and off.  
Who is correct?  
A. A only            C. Both A and B  
B. B only            D. Neither A nor B
- In a full hybrid HEV, which component is responsible for recharging the 12-volt battery from the 300-volt direct current system?  
A. The battery control module.  
B. The belt driven generator.  
C. The DC/DC converter.  
D. The LV control module.

# LIGHTING CIRCUITS

### UPON COMPLETION AND REVIEW OF THIS CHAPTER, YOU SHOULD BE ABLE TO UNDERSTAND AND DESCRIBE:

- The operation and construction of automotive lamps.
- The differences between conventional sealed-beam, halogen, and composite headlight lamps.
- The operation and controlled circuits of the headlight switch.
- The operation of the dimmer switch.
- The operation of the most common styles of concealed headlight systems.
- The operation of the various exterior light systems, including parking, tail, brake, turn, side, clearance, and hazard warning lights.
- The operating principles of the turn signal and hazard light flashers.
- The operation of the various interior light systems, including courtesy and instrument panel lights.

### INTRODUCTION

Today's technician is required to understand the operation and purpose of the various lighting circuits on the vehicle. The addition of computers and their many sensors and actuators (some that interlink to the lighting circuits) make it impossible for technicians to just bypass part of the circuit and rewire the system to their own standards. If a lighting circuit is not operating properly, the safety of the driver, the passengers, people in other vehicles, and pedestrians are in jeopardy. When today's technician performs repairs on the lighting systems, the repairs must meet at least two requirements: They must assure vehicle safety and meet all applicable laws.

The lighting circuits of today's vehicles can consist of more than 50 light bulbs and hundreds of feet of wiring. Incorporated within these circuits are circuit protectors, relays, switches, lamps, and connectors. In addition, more sophisticated lighting systems use computers and sensors. The lighting circuits consist of an array of interior and exterior lights, including headlights, taillights, parking lights, stoplights, marker lights, dash instrument lights, courtesy lights, and so on.

The lighting circuits are largely regulated by federal laws, so the systems are similar between the various manufacturers. However, there are variations. Before attempting to do any repairs on an unfamiliar circuit, the technician should always refer to the manufacturer's service information. This chapter provides information about the types of lamps used, describes the headlight circuit, discusses different types of concealed headlight systems, and explores the various exterior and interior light circuits individually.



# LAMPS

A **lamp** generates light through a process of changing energy forms called **incandescence**. The lamp produces light as a result of current flow through a filament. The filament is enclosed within a glass envelope and is a type of resistance wire that is generally made from tungsten. As current flows through the tungsten filament, it gets very hot (Figure 8-1). The changing of electrical energy to heat energy in the resistive wire filament is so intense that the filament starts to glow and emits light. The lamp must have a vacuum surrounding the filament to prevent it from burning so hot that the filament burns in two. The glass envelope that encloses the filament maintains the presence of vacuum. When the lamp is manufactured, all the air is removed and the glass envelope seals out the air. If air is allowed to enter the lamp, the oxygen would cause the filament to oxidize and burn up.

Many lamps are designed to execute more than one function. A **double-filament lamp** has two filaments so the bulb can perform more than one function (Figure 8-2). It can be used in the stop light circuit, taillight circuit, and turn signal circuit combined.

It is important that any burned-out lamp be replaced with the correct lamp. The technician can determine what lamp to use by checking the lamp's standard trade number (Table 8-1).

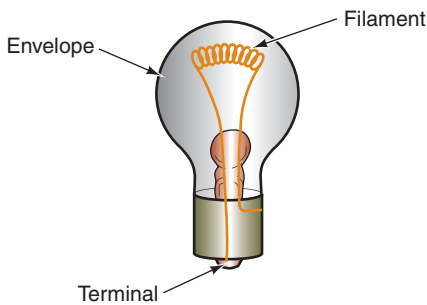


FIGURE 8-1 A single-filament bulb.

© Delmar/Cengage Learning

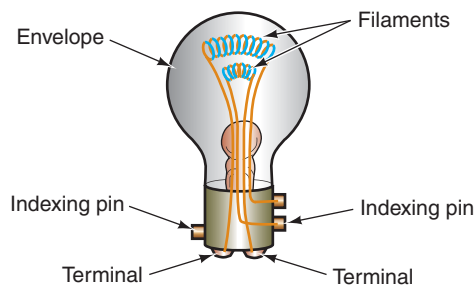


FIGURE 8-2 A double-filament lamp.

© Delmar/Cengage Learning

TABLE 8-1 A TABLE OF SOME TYPICAL AUTOMOTIVE LIGHT BULB EXAMPLES.

TYPICAL AUTOMOTIVE LIGHT BULBS			
Trade Number	Design Volts	Design Amperes	Watts: $P = A \times V$
168	14.0	0.35	4.9
192	13.0	0.33	4.3
194	14.0	0.27	3.8
194E-1	14.0	0.27	3.8
194NA	14.0	0.27	3.8
912	12.8	1.00	12.8
921	12.8	1.40	17.92
1141	12.8	1.44	18.4
1142	12.8	1.44	18.4
1156	12.8	2.10	26.9
1157	12.8	2.10/0.59	26.9/7.6
1157A	12.8	2.10/0.59	26.9/7.6
1157NA	12.8	2.10/0.59	26.9/7.6
2057	12.8	2.10/0.48	26.9/6.1
2057NA	12.8	2.10/0.48	26.9/6.1
3057	12.8–14.0	2.1/0.48	26.9/6.72
3156	12.8	2.10	26.9
3157	12.8–14.0	2.1/0.59	26.9/8.26
3457	12.8–14.0	2.23/0.59	28.5/8.26
4157	12.8–14.0	2.23/0.59	28.5/8.26
6411	12.0	0.833	10.0
6418	12.0	0.417	5.0
7440	12.0	1.75	21.0
7443	12.0	1.75/0.417	21.0/5.0
7507	12.0	1.75	21.0



## HEADLIGHTS

There are four basic types of headlights used on automobiles today: (1) standard sealed beam, (2) halogen sealed beam, (3) composite, and (4) high-intensity discharge (HID).

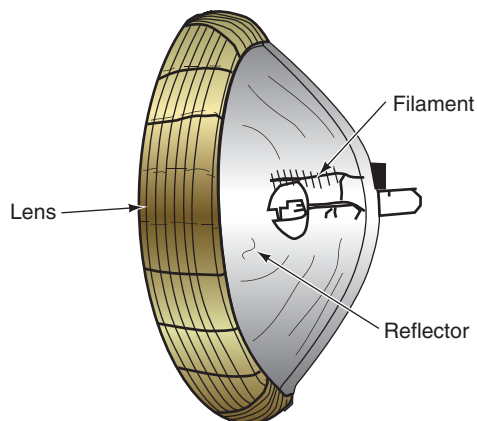
### Shop Manual

Chapter 8, page 312

### Sealed-Beam Headlights

From 1939 to about 1975, the headlights used on vehicles remained virtually unchanged. During this time, the headlight was a round lamp. The introduction of the rectangular headlight in 1975 enabled the vehicle manufacturers to lower the hood line of their vehicles. Both the round and rectangular headlights were **sealed-beam** construction (Figure 8-3). The sealed-beam headlight is a self-contained glass unit made up of a filament, an inner reflector, and an outer glass lens. The standard sealed-beam headlight does not surround the filament with its own glass envelope (bulb). The glass lens is fused to the parabolic reflector, which is sprayed with **vaporized aluminum** that gives a reflecting surface that is comparable to silver. The inside of the lamp is filled with argon gas. All oxygen must be removed from the standard sealed-beam headlight to prevent the filament from becoming oxidized. The reflector intensifies the light that the filament produces, and the lens directs the light to form the required light beam pattern.

The lens is designed to produce a broad, flat beam. The light from the reflector is passed through concave **prisms** in the glass lens (Figure 8-4). Lens prisms redirect the light beam and create a broad, flat beam. The illustration (Figure 8-5) shows the horizontal spreading and the vertical control of the light beam to prevent upward glaring.



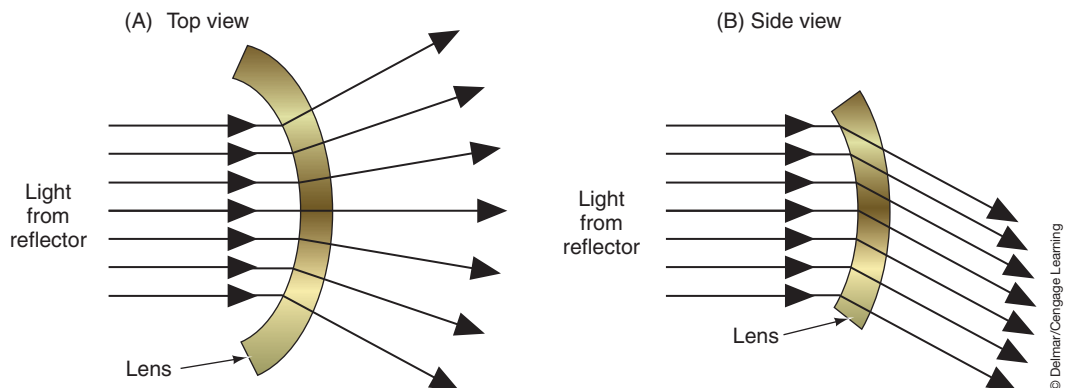
© Delmar/Cengage Learning



© Delmar/Cengage Learning

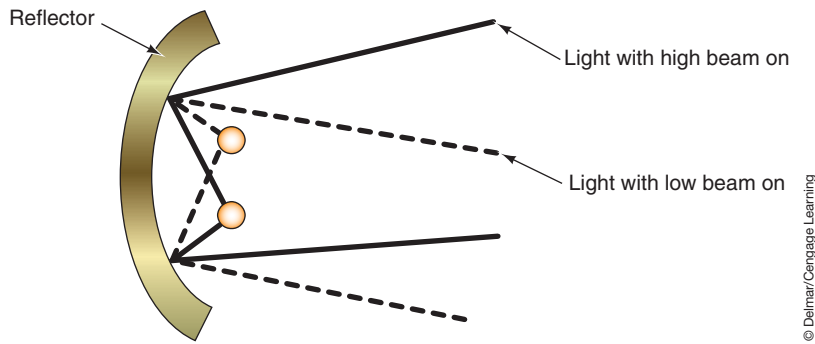
FIGURE 8-3 Sealed-beam headlight construction.

FIGURE 8-4 The lens uses prisms to redirect the light.



© Delmar/Cengage Learning

FIGURE 8-5 The prism directs the beam into (A) a flat horizontal pattern and (B) downward.



**FIGURE 8-6** Filament placement controls the projection of the light beam.

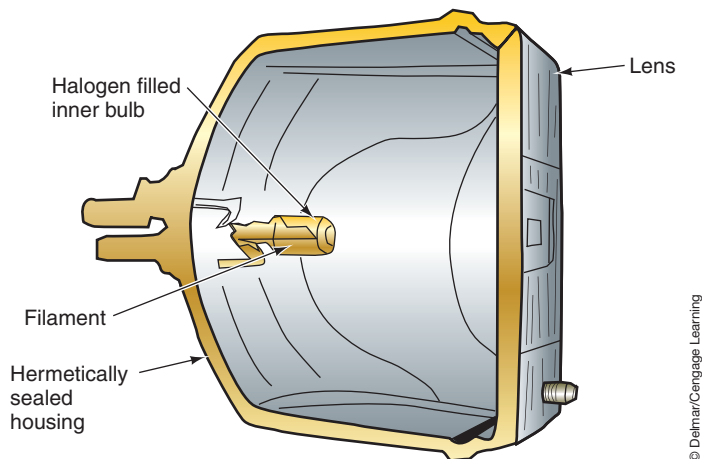
By placing the filament in different locations on the reflector, the direction of the light beam is controlled (Figure 8-6). In a dual-filament lamp, the lower filament is used for the high beam and the upper filament is used for the low beam.

## Halogen Headlights

The **halogen** lamp most commonly used in automotive applications consists of a small bulb filled with iodine vapor. The bulb is made of a high-temperature-resistant quartz that surrounds a tungsten filament. This inner bulb is installed in a sealed glass housing (Figure 8-7). With the halogen added to the bulb, the tungsten filament is capable of withstanding higher temperatures than that of conventional sealed-beam lamps. The halogen lamp can withstand higher temperatures and thus is able to burn brighter.

In a conventional sealed-beam headlight, the heating of the filament causes atoms of tungsten to be released from the surface of the filament. These released atoms deposit on the glass envelope and create black spots that affect the light output of the lamp. In a halogen lamp, the iodine vapor causes the released tungsten atoms to be redeposited onto the filament. This virtually eliminates any black spots. It also allows for increased high-beam output of 25% over conventional lamps and for longer bulb life.

**AUTHOR'S NOTE:** Because the filament is contained in its own bulb, cracking or breaking of the lens does not prevent halogen headlight operation. As long as the filament envelope has not been broken, the filament will continue to operate. However, a broken lens will result in poor light quality and should be replaced.



**FIGURE 8-7** A halogen sealed-beam headlight with iodine vapor bulb.



## A BIT OF HISTORY

Improved sealed-beam headlamps were introduced in 1955.

**Halogen** is the term used to identify a group of chemically related nonmetallic elements. These elements include chlorine, fluorine, and iodine.

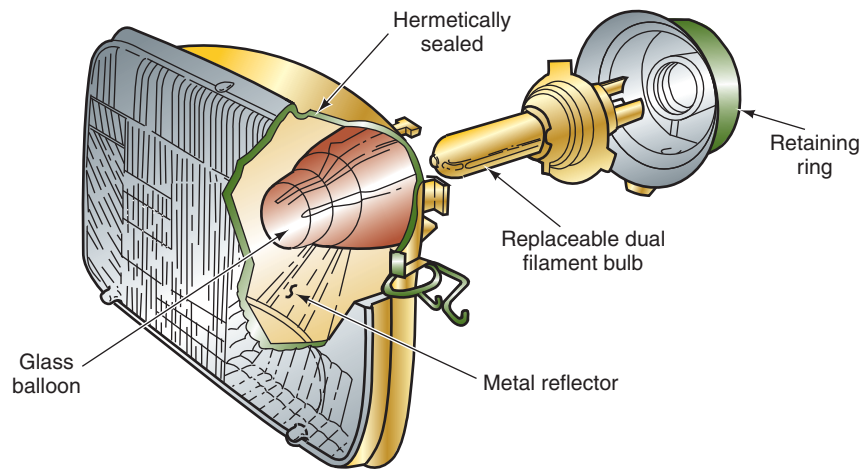


FIGURE 8-8 A composite headlight system with a replaceable halogen bulb.

© Delmar/Cengage Learning

### Shop Manual

Chapter 8, page 314

Many of today's vehicles have a halogen headlight system. This system is called **composite headlights**.

## Composite Headlights

By using the **composite headlight** system, vehicle manufacturers are able to produce any style of headlight lens they desire (Figure 8-8). This improves the aerodynamics, fuel economy, and styling of the vehicle. Composite headlight systems use a replaceable halogen bulb.

Many manufacturers vent the composite headlight housing because of the increased amount of heat these bulbs develop. Because the housings are vented, condensation may develop inside the lens assembly. This condensation is not harmful to the bulb and does not affect headlight operation. When the headlights are turned on, the heat generated from the halogen bulbs will dissipate the condensation quickly. Ford uses integrated nonvented composite headlights. On these vehicles, condensation is not considered normal. The assembly should be replaced.

### Shop Manual

Chapter 8, page 315

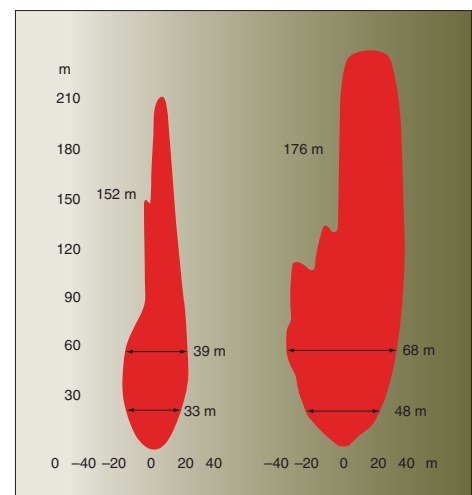
## HID Headlights

**High-intensity discharge (HID)** headlamps are the latest headlight development. HID headlights use an inert gas to amplify the light produced by arcing across two electrodes. These headlamps (Figure 8-9) put out three times more light and twice the light spread on the road than conventional halogen headlamps (Figure 8-10). They also use about two-thirds



© Delmar/Cengage Learning

FIGURE 8-9 HID headlamps; note the reduced size of the headlamp assemblies.



© Delmar/Cengage Learning

FIGURE 8-10 Comparison between light intensity and patter. Halogen lamp is shown on the left and the xenon (HID) lamp is on the right.



FIGURE 8-11 HID bulb element.

© Delmar/Cengage Learning

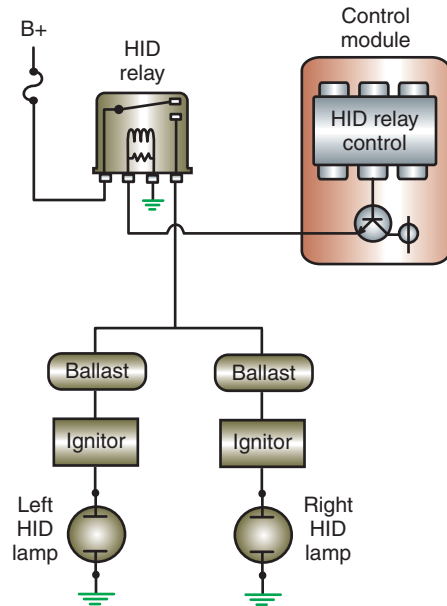


FIGURE 8-12 HID headlight schematic showing the use of a ballast and ignitor.

© Delmar/Cengage Learning

less power to operate and will last two to three times longer. HID lamps produce light in both ultraviolet and visible wavelengths. This advantage allows highway signs and other reflective materials to glow. This type of lamp first appeared on select models from BMW in 1993, Ford in 1995, and Porsche in 1996.

The HID lamp (Figure 8-11) consists of an outer bulb made of cerium-doped quartz that houses the inner bulb (arc tube). The inner bulb is made of fused quartz and contains two tungsten electrodes. It also is filled with xenon gas, mercury, and metal halides (salts).

The HID lamp does not rely on a glowing filament for light. Instead it uses a high-voltage arcing bridge across the air gap between the electrodes. The xenon gas amplifies the light intensity given off by the arcing. The HID system requires the use of an ignitor and ballast to provide the electrical energy required to arc the electrodes (Figure 8-12). The ignitor is usually built into the base of the HID bulb and will provide the initial 15,000 to 25,000 volts to jump the gap. Once the gap has been jumped and the gas warms, then the ballast will provide the required voltage to maintain current flow across the gap. The ballast must deliver 35 watts to the lamp when the voltage across the lamp is between 70 and 110 volts.

The greater light output of these lamps allows the headlamp assembly to be smaller and lighter. These advantages allow designers more flexibility in body designs as they attempt to make their vehicles more aerodynamic and efficient. For example, the Infiniti Q45 models are equipped with a seven-lens HID system (Figure 8-13) to provide stylish looks and high lamp output.

## Bi-Xenon Headlamps

Due to the increased amount of light that the HID headlamps produces, they are not used in a quad headlight system as a high beam lamp. Instead they are used as the low beam lamp only and a halogen bulb for the high beam. Since the quad headlamp system uses all four bulbs for high beam operation, using a quad lamp system with HID lamps would blind any oncoming drivers due to the excessive amount of light output. Also, it is not possible to reduce the light intensity of an HID by PWM of the current to the element.

To overcome these issues and to still be able use the HID, manufacturers have started to use **bi-xenon headlamps** in their dual headlamp systems. Bi-xenon refers to the use of a



© Delmar/Cengage Learning

**FIGURE 8-13** Seven-lens HID headlamp.

single xenon lamp to provide both the high beam and the low beam operation. The full light output is used to produce the high beam. Low beam is formed by either moving the xenon bulb within the lens or by moving a shutter between the bulb and the lens.

Systems that use the shutter will have a motor within the headlamp assembly that raises and lowers the shutter. The position of the shutter dictates the amount of the projected light that will be allowed to escape from the lens and its pattern.



## A BIT OF HISTORY

The Model T Ford used a headlight system that had a replaceable bulb. The owner's manual warned against touching the reflector except with a soft cloth.

**AUTHOR'S NOTE:** The actual direction that the shutter travels, to block or unblock varies based on application.

In some systems a motor is used to change the position of the bulb. The bulb is physically raised in the reflector housing to produce the high beam output. In low beam mode, the bulb is lowered in the reflector housing. The amount of reflection dictates the light intensity and pattern.

Using the same lamp for both low and high beam operation permits both modes to have the same light color. This produces less visual contrast when switching between modes and is less stressful to the eyes of the driver.

## HEADLIGHT SWITCHES

The headlight switch may be located either on the dash by the instrument panel or on the steering column (Figure 8-14). It controls most of the vehicle's lighting systems. The most common style of headlight switch is the three-position type with OFF, PARK, and HEADLIGHT positions. The headlight switch will generally receive direct battery voltage to two terminals of the switch. This allows the light circuits to be operated without having the ignition switch in the RUN or ACC (accessory) position.

When the headlight switch is in the OFF position, the open contacts prevent battery voltage from continuing to the lamps. When the switch is in the PARK position, battery voltage that is present at terminal 5 is able to be applied through the closed contacts to the side marker, taillight, license plate, and instrument cluster lights (Figure 8-15). This circuit is usually protected by a 15- to 20-ampere fuse that is separate from the headlight circuit.

When the switch is located in the HEADLIGHT position, battery voltage that is present at terminal 1 is able to be applied through the circuit breaker and the closed contacts to light the headlights. Battery voltage from terminal 5 continues to light the lights that were on in the PARK position (Figure 8-16). The circuit breaker is used to prevent temporary overloads to the system from totally disabling the headlights.

### Shop Manual

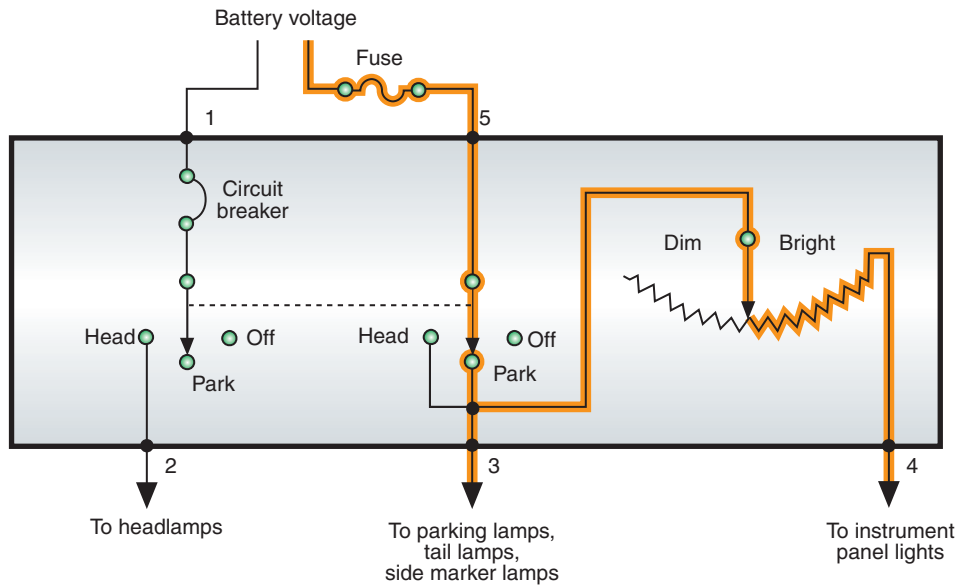
Chapter 8, page 323





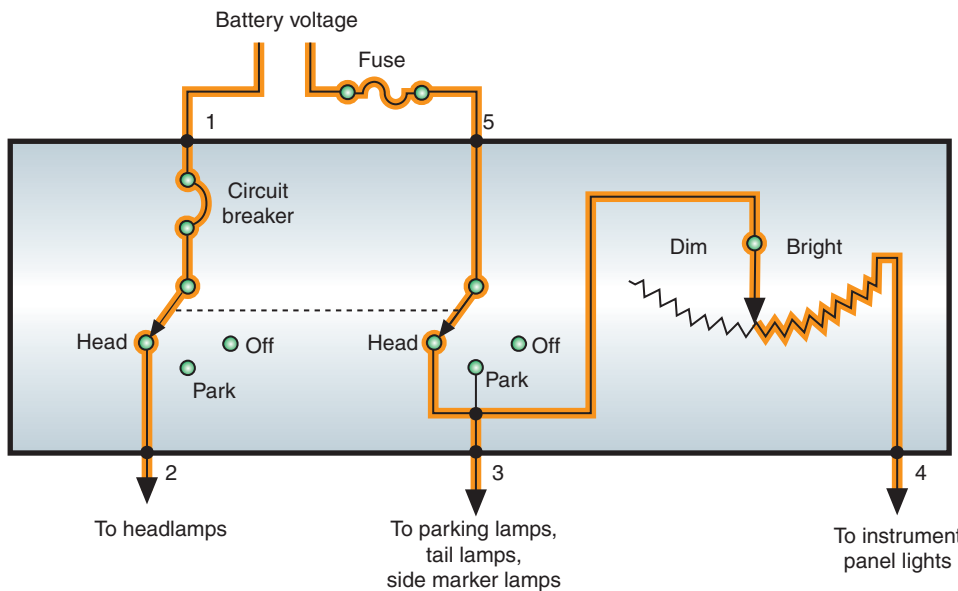
© Delmar/Cengage Learning

**FIGURE 8-14** (A) Instrument panel-mounted headlight switch. (B) Steering column-mounted headlight switch.



© Delmar/Cengage Learning

**FIGURE 8-15** Operation with the headlight switch in the PARK position.



© Delmar/Cengage Learning

**FIGURE 8-16** Operation with the headlight switch in the HEADLIGHT position.



The rheostat is a variable resistor that the driver uses to control the instrument cluster illumination lamp brightness. As the driver turns the light switch knob, the resistance in the rheostat is changed. The greater the resistance, the dimmer the instrument panel illumination lights glow. In vehicles that have the headlight switch located in the steering column, the rheostat may be a separate unit located on the dash near the instrument panel.

### Shop Manual

Chapter 8, page 326



### A BIT OF HISTORY

Foot-operated dimmer switches became standard equipment in 1923.

### Shop Manual

Chapter 8, page 321

## Dimmer Switches

The **dimmer switch** provides the means for the driver to select either high- or low-beam operation, and to switch between the two. The dimmer switch is connected in series within the headlight circuit and controls the current path for high and low beams. In the past, the most common location of the dimmer switch was on the floor board next to the left kick panel. The driver operates this switch by pressing on it with a foot. Positioning the switch on the floor board made the switch subject to damage because of rust, dirt, and so forth. Most newer vehicles locate the dimmer switch on the steering column to prevent early failure and to increase driver accessibility (Figure 8-17). This switch is activated by the driver pulling the stock switch (turn signal lever) rearward.

## Headlight Circuits

The complete headlight circuit consists of the headlight switch, dimmer switch, high-beam indicator, and the headlights. When the headlight switch is pulled to the HEADLIGHT position, current flows to the dimmer switch through the closed contacts (Figure 8-18). If the dimmer switch is in the LOW position, current flows through the low-beam filament of the headlights. When the dimmer switch is placed on the HIGH position, current flows through the high-beam filaments of the headlights (Figure 8-19).

The headlight circuits just discussed are designed with insulated side switches and grounded bulbs. In this system, battery voltage is present to the headlight switch. The switch must be closed in order for current to flow through the filaments and to ground. The circuit is complete because the headlights are grounded to the vehicle body or chassis. Many import manufacturers use a system design that has insulated bulbs and ground side switches. In this system, when the headlight switch is located in the HEADLIGHT position, the contacts are closed to complete the circuit path to ground. The headlight switch is located after the headlight lamps in the circuit. Battery voltage is applied directly to the headlights when the relays are closed. But the headlights will not light until the switch completes the ground side of the relay circuits. In this system, both the headlight and dimmer switches complete the circuits to ground.

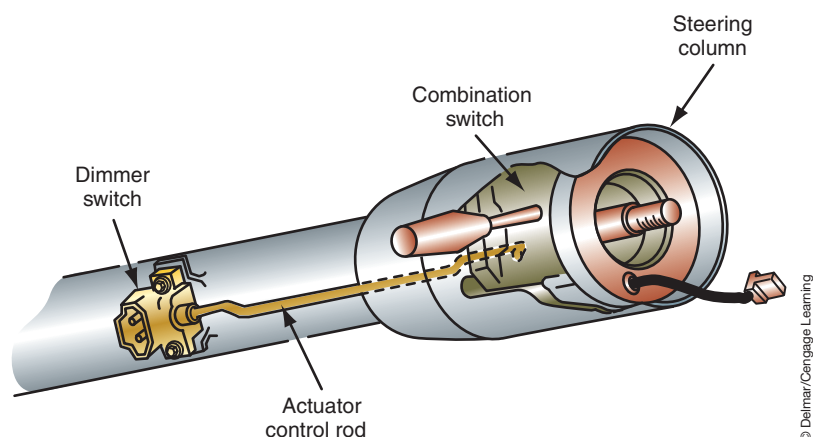
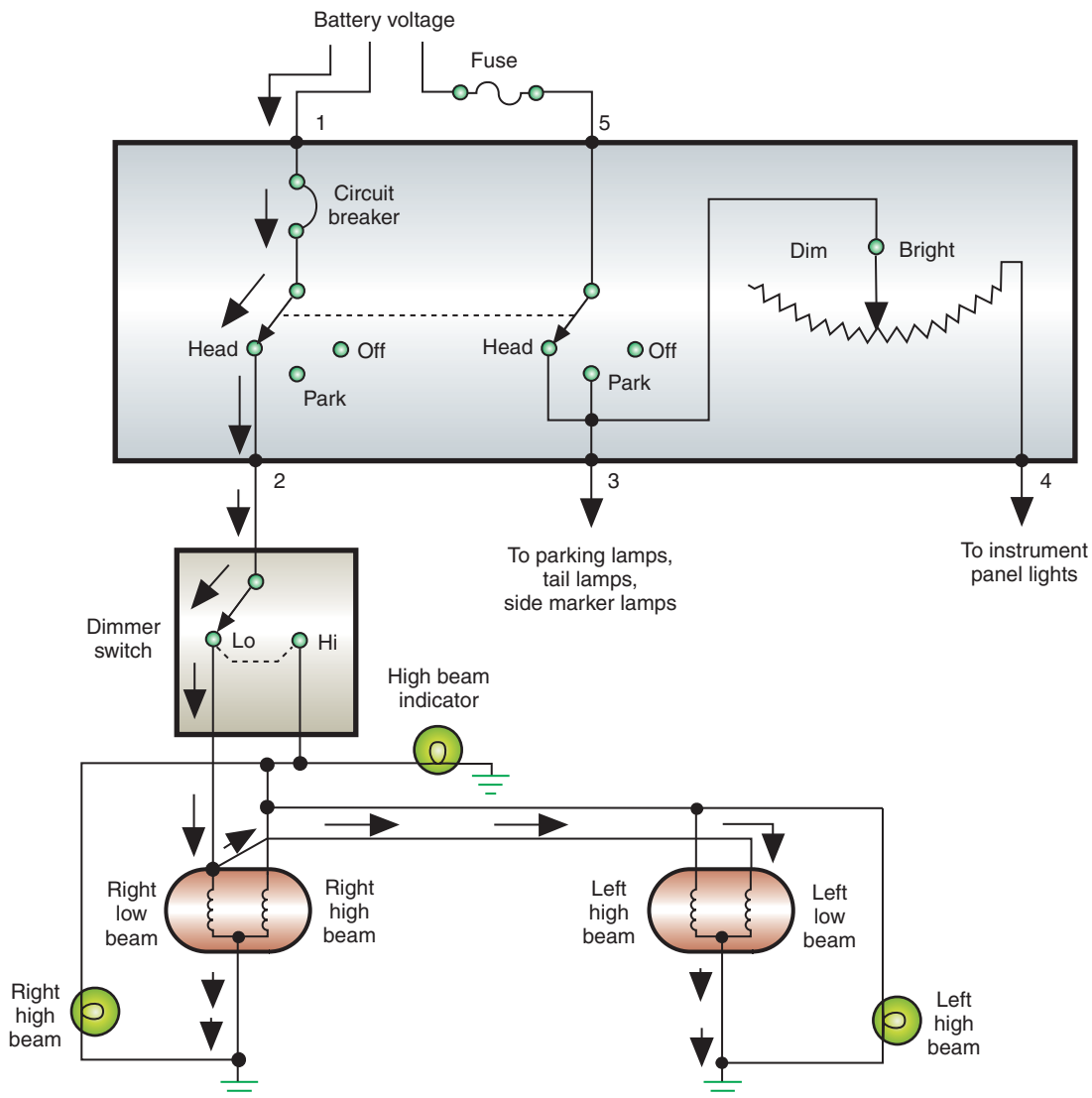


FIGURE 8-17 A steering column—mounted dimmer switch.



© Delmar/Cengage Learning

**FIGURE 8-18** A headlight circuit indicating current flow with the dimmer switch in the LOW-BEAM position.

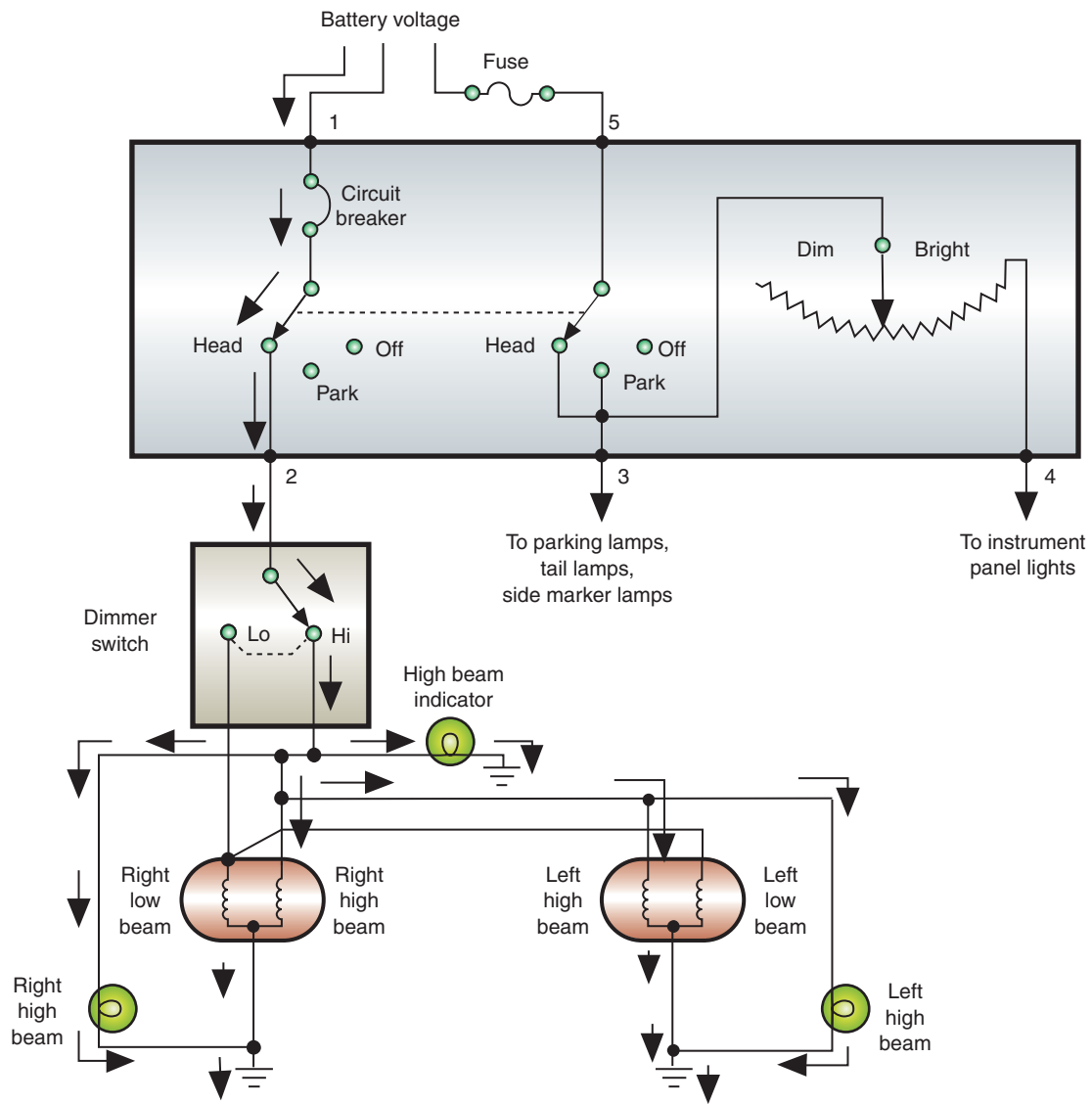
No matter if the headlights use insulated side switches or ground side switches, each system is wired in parallel. This prevents total headlight failure if one filament burns out.

## CONCEALED HEADLIGHTS

A vehicle equipped with a **concealed headlight** system hides the lamps behind doors when the headlights are turned off. When the headlight switch is turned to the HEADLIGHT position, the headlight doors open (Figure 8-20). Early systems used vacuum-controlled doors. Today most systems use electric motors.

Electrically controlled systems can use either a torsion bar and a single motor to open both headlight doors, or a separate motor for each headlight door. Most systems will use limit switches to stop current flow when the doors are full up or full down. These switches generally operate from a cam on the reaction motor (Figure 8-21). Only one limit switch can be closed at a time. When the door is full up, the opening limit switch opens and the closing limit switch closes. When the door is full down, the closing limit switch is open and the opening limit switch closes. This prepares the reaction motor for the next time that the system is activated or deactivated.

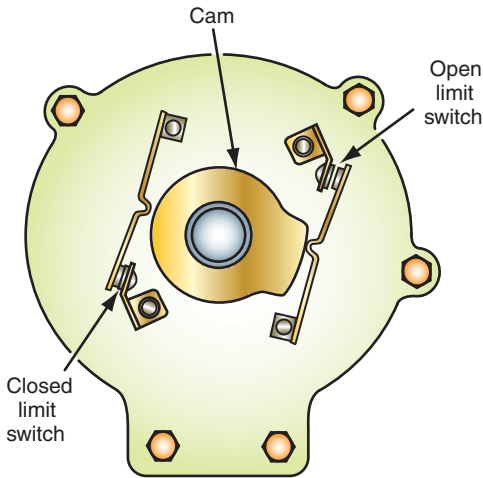
**Shop Manual**  
Chapter 8, page 322



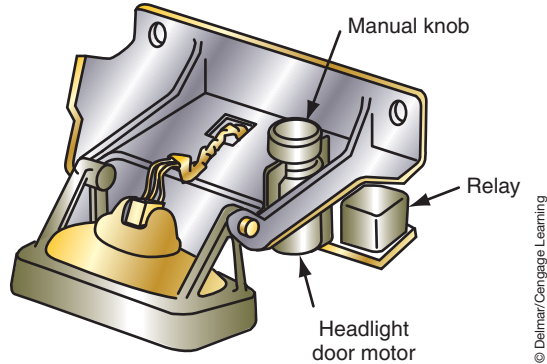
**FIGURE 8-19** A headlight circuit indicating current flow with the dimmer switch in the HIGH-BEAM position.



**FIGURE 8-20** Concealed headlights enhance the vehicle's styling and aerodynamics.



**FIGURE 8-21** Most limit switches operate off of a cam on the motor.

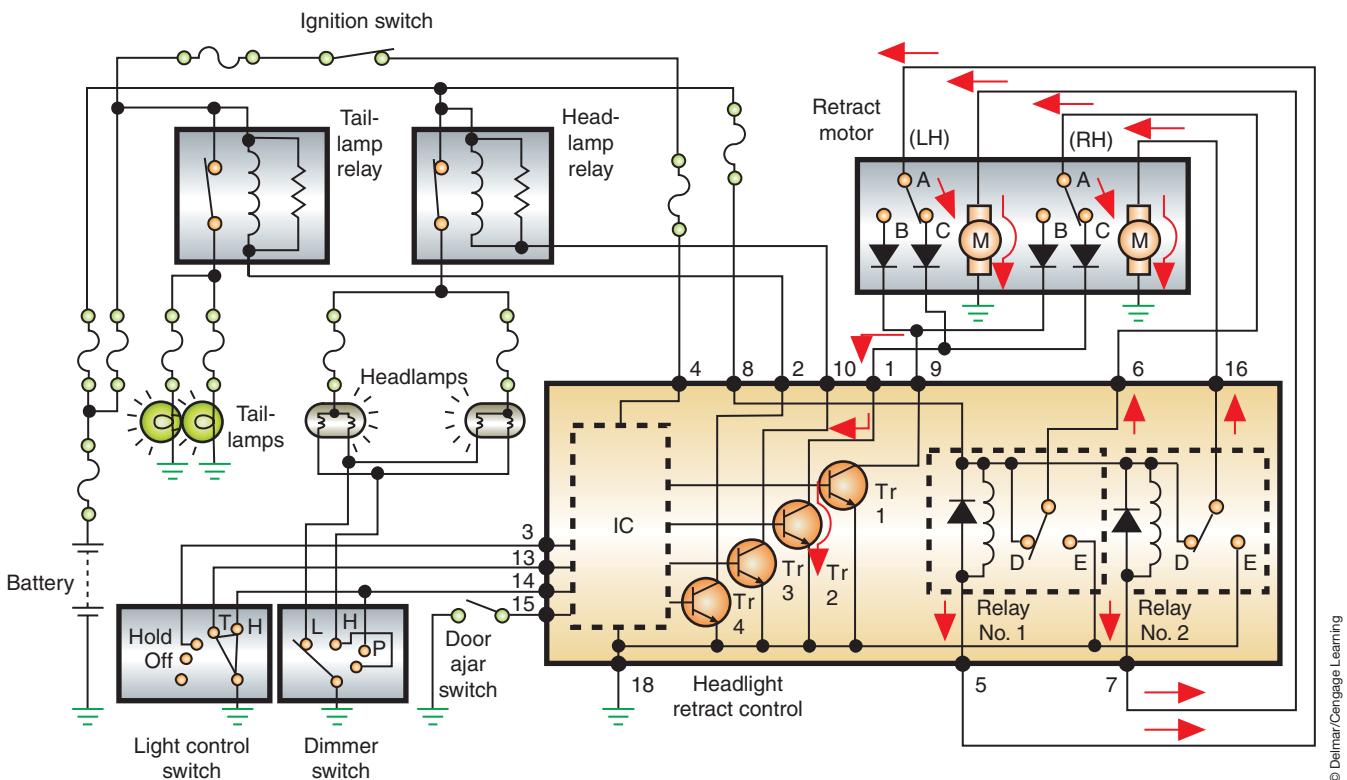


**FIGURE 8-22** An electrically controlled concealed headlight system with a manual control knob.

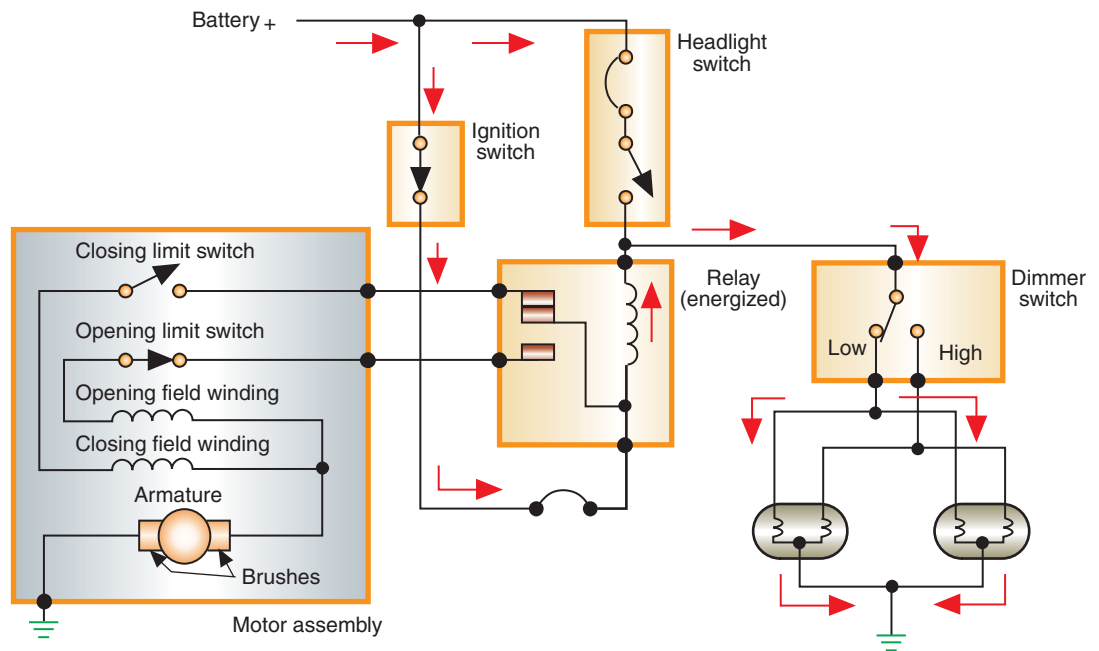
The electrically operated concealed headlight system provides a provision for manually opening the doors in the event of a system failure (Figure 8-22).

Figure 8-23 illustrates a system that incorporates an integrated chip (IC). Each motor has its own relay and limiting switches. When the limit switches are in the A-B position, the doors are full open. When the switches are in the A-C position, the doors are full closed.

Figure 8-24 illustrates another method used to operate the electric motors of a concealed headlight system. When the ignition switch is in the RUN position but the headlight switch is off, current flows through the ignition switch to the relay. The relay is energized because the coil is grounded through the headlight filaments. With the coil energized, the relay points



**FIGURE 8-23** Pop-up headlight system wiring schematic.



**FIGURE 8-24** Current flow with the headlight switch OFF and the headlight doors closed.

© Delmar/Cengage Learning

close. However, the door closing limit switch is open. This results in a de-energized door closing field winding.

When the headlight switch is turned to the HEADLIGHT position, current continues to flow to the relay coil through the ignition switch. However, current is also sent to the other side of the relay coil from the headlight switch. Voltage is equal on both sides of the relay coil, so there is no voltage potential and the coil is de-energized. The relay contact points close to the door opening field winding. With the door opening limit switch closed, the motor operates until the limit switch is opened.

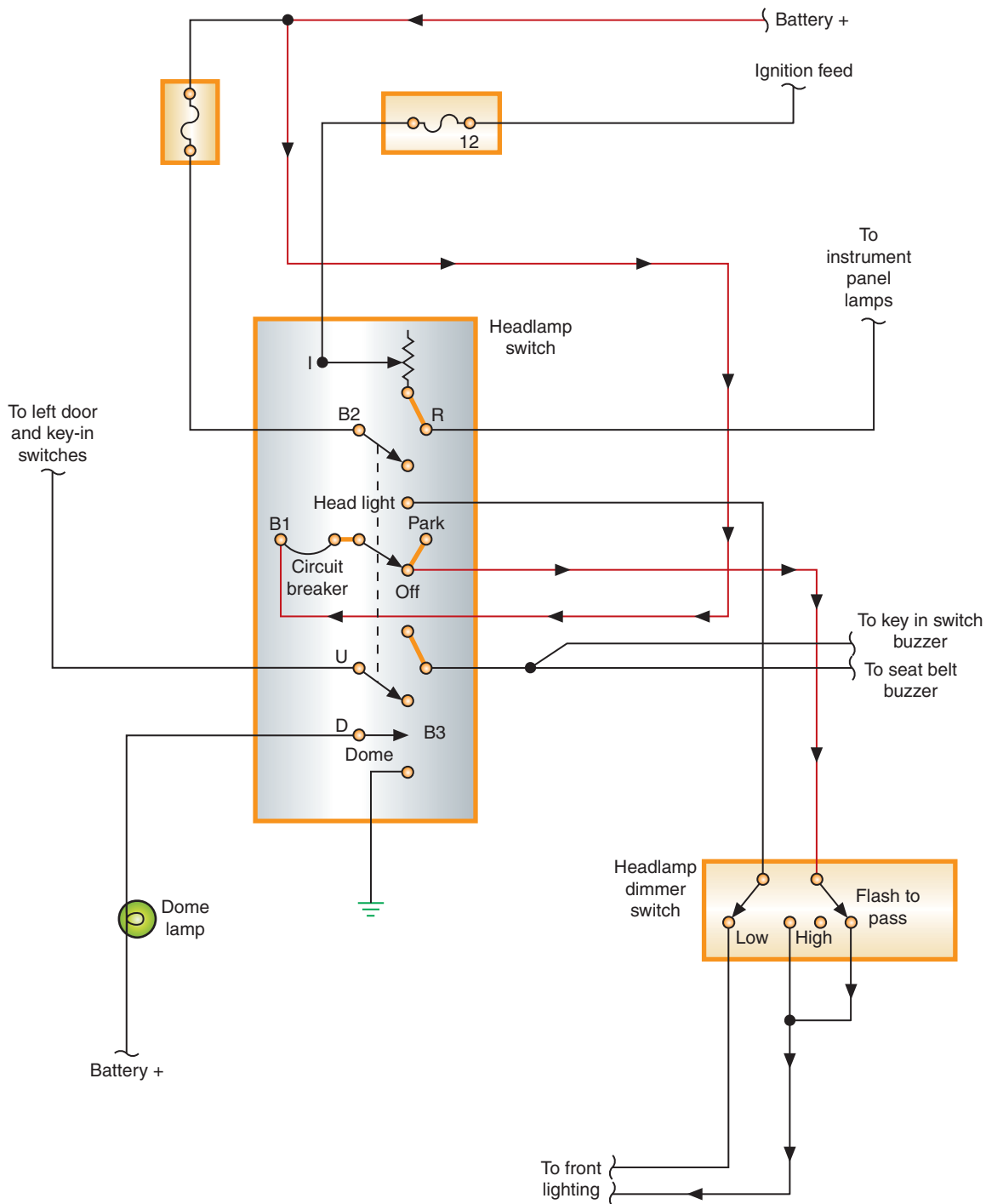
## FLASH TO PASS

Many steering column-mounted dimmer switches have an additional feature called “flash to pass.” This circuit illuminates the high-beam headlights even with the headlight switch in the OFF or PARK position (Figure 8-25). In this illustration, battery voltage is supplied to terminal B1 of the headlight switch and on to the dimmer switch. Battery voltage is available to the dimmer switch through this wire in both the OFF and PARK positions of the headlight switch. When the driver activates the flash-to-pass feature, the contacts in the dimmer switch complete the circuit to the high-beam filaments.

## EXTERIOR LIGHTS

When the headlight switch is placed in the PARK or HEADLIGHT position, the front parking lights, taillights, side marker lights, and rear license plate light are all turned on. The front parking lights usually use dual-filament bulbs. The other filament is used for the turn signals and hazard lights.

Most taillight assemblies include the brake, parking, rear turn signal, and rear hazard lights. The center high mounted stop light (CHMSL), back-up lights, and license plate lights can be included as part of the taillight circuit design. Depending on the manufacturer, the taillight assembly can be wired to use single-filament or dual-filament bulbs. When single-filament bulbs are used, the taillight assembly is wired as a three-bulb circuit. A three-bulb circuit uses one bulb each for the tail, brake, and turn signal lights on each side of the vehicle.



**FIGURE 8-25** Flash-to-pass feature added to the headlight circuit.

© Delmar/Cengage Learning

When dual-filament bulbs are used, the system is wired as a two-bulb circuit. Each bulb can perform more than one function.

## Taillight Assemblies

The headlight switch controls parking lights and taillights. They can be turned on without having to turn on the headlights. Usually, the first detent on the headlight switch is provided for this function. Figure 8-26 illustrates a parking light and taillight circuit. This circuit is controlled by the headlight switch. Thus the lights can be operated with the ignition switch in the OFF position.

### Shop Manual

Chapter 8, page 329

Parking lights can also be referred to as running lights.



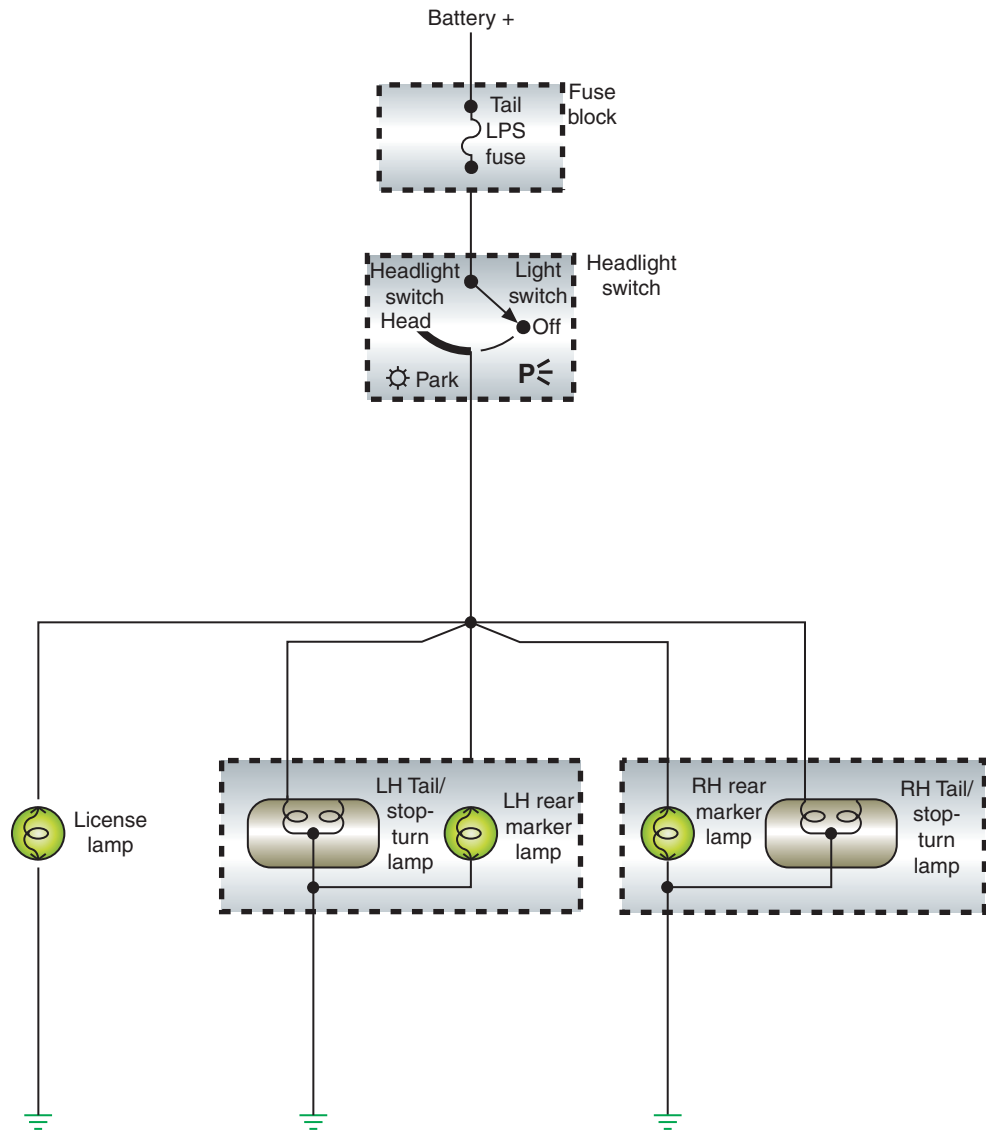


FIGURE 8-26 An example of a two-bulb taillight circuit.

© Delmar/Cengage Learning



## A BIT OF HISTORY

Taillights on both sides of the car didn't appear until 1929.

### Shop Manual

Chapter 8, page 330

In a three-bulb taillight system, the brake lights are controlled directly by the brake light switch. In most applications, the brake light switch is attached to the brake pedal. When the brakes are applied, the pedal moves down and the switch plunger closes the contact points and lights the brake lights (Figure 8-27). On some vehicles, the brake light switch may be a pressure-sensitive switch located in the brake master cylinder. When the brakes are applied, the pressure developed in the master cylinder closes the switch to light the lamps.

The brake light switch receives direct battery voltage through a fuse, which allows the brake lights to operate when the ignition switch is in the OFF position. Once the switch is closed, voltage is applied to the brake lights. The brake lights on both sides of the vehicle are wired in parallel. The bulb is grounded to complete the circuit.

Many brake light systems use dual-filament bulbs that perform multifunctions. Usually, the filament of the dual-filament bulb, which is also used by the turn signal and hazard lights, is used for the brake lights (the high-intensity filament). In this type of circuit, the brake lights are wired through the turn signal and hazard switches. If neither turn signal is on, the current is sent to both of the brake lights (Figure 8-28). If the left turn signal is on, current for the right brake light is sent to the lamp through the turn signal switch terminal 5. The left brake light

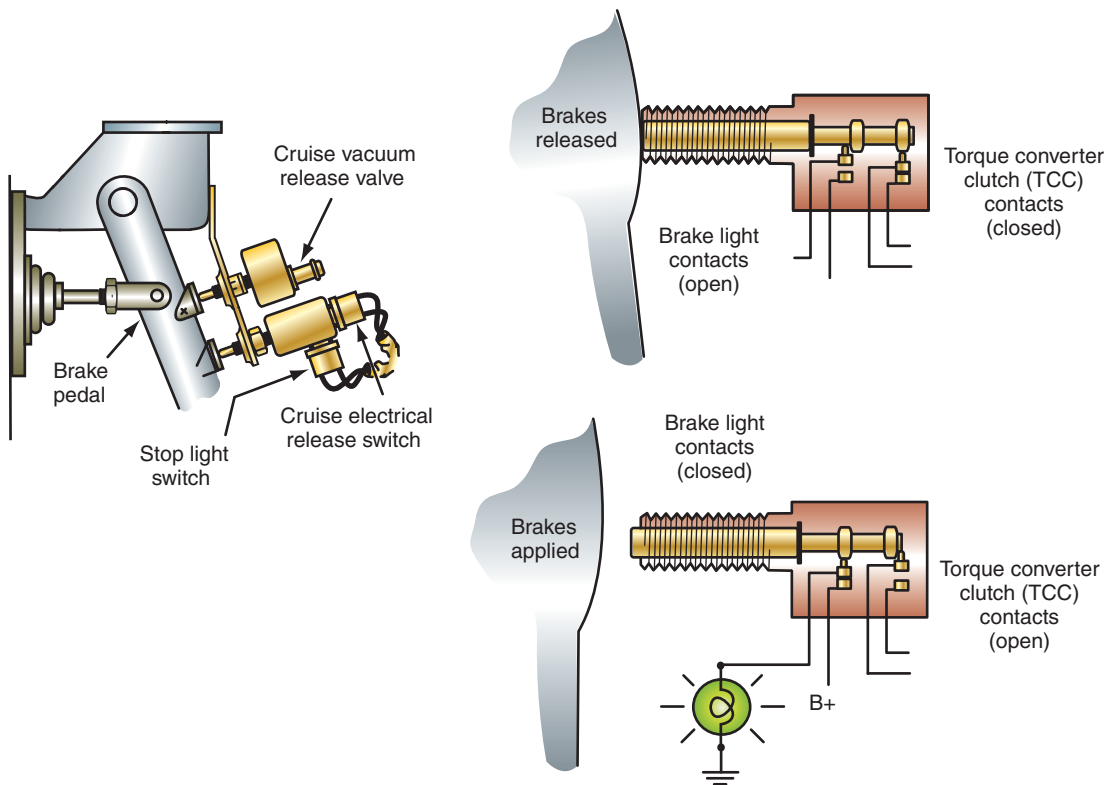


FIGURE 8-27 Operation of a brake light switch.

© Delmar/Cengage Learning



## A BIT OF HISTORY

In 1921, turn signals were made standard equipment by Leland Lincoln. This marque later joined Ford Motor Company. Leland Lincolns were built by Henry Leland, who was the originator of Cadillac. Early turn signals were not like those used today; many were steel arms with reflective material on them. These arms pivoted out on the side of the car as it was turning. This style continued for many years until Buick introduced electric turn signals to the public in 1939.

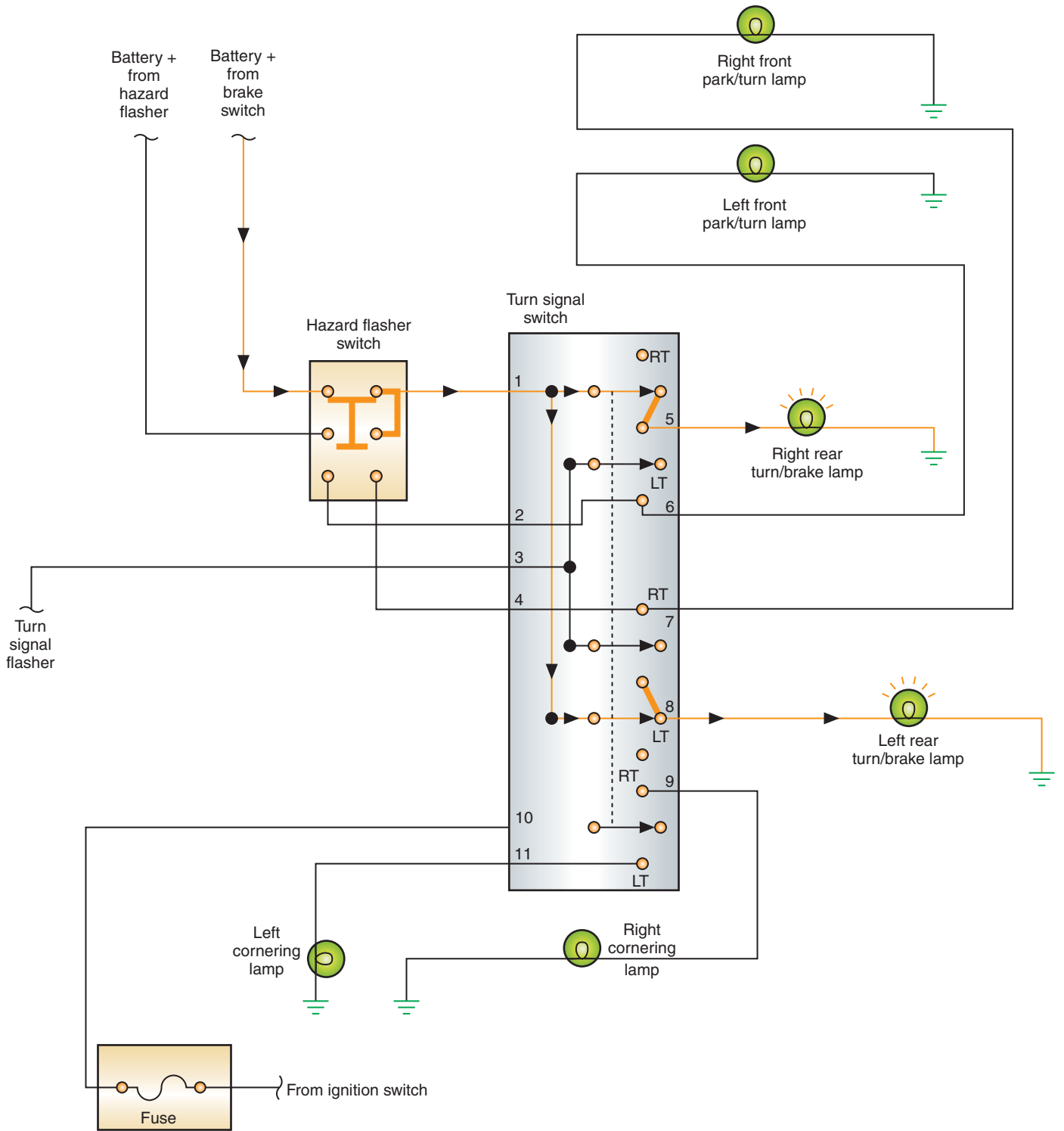
does not receive any voltage from the brake switch because the turn signal switch opens that circuit (Figure 8-29). The left-rear lamp will flash as the turn signal flasher provides pulsed voltage into switch terminal 3 and out terminal 8.

**AUTHOR'S NOTE:** Because the turn signal switches used in a two-bulb system also control a portion of the operation of the brake lights, they have a complex system of contact points. The technician must remember that many brake light problems are caused by worn contact points in the turn signal switch.

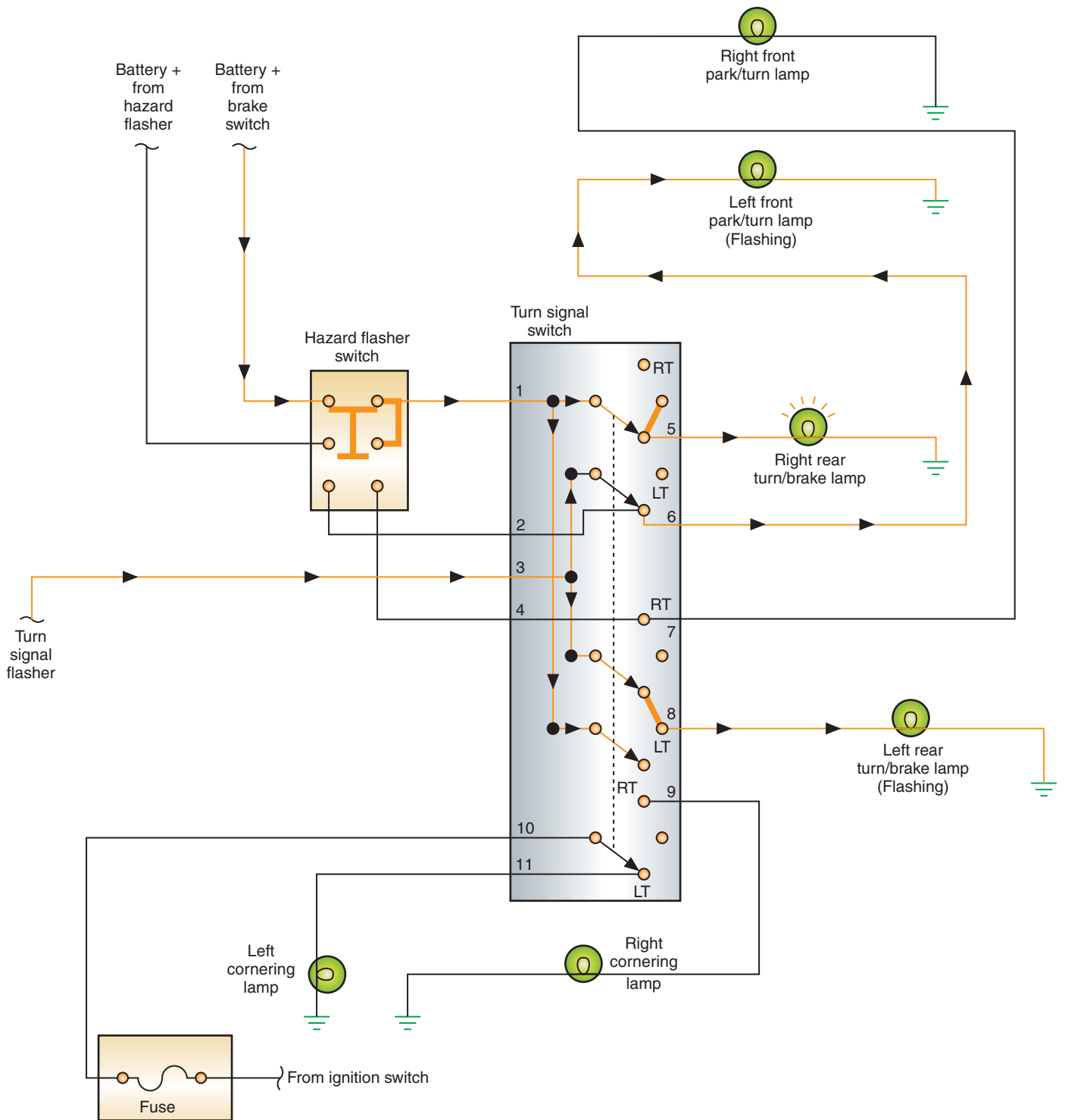
All brake lights must be red and, starting in 1986, the vehicle must have a center high mounted stop lamp (CHMSL). This lamp must be located on the center line of the vehicle and no lower than 3 inches below the bottom of the rear window (6 inches on convertibles). In a three-bulb system, wiring for the CHMSL is in parallel to the brake lights (Figure 8-30).

In a two-bulb circuit, the CHMSL can be wired in one of two common methods. The first method is to connect to the brake light circuit between the brake light switch and the turn signal switch (Figure 8-31). This method is simple to perform. However, it increases the number of conductors needed in the harness.

The most common method used by manufacturers is to install diodes in the conductors that are connected between the left- and right-side bulbs (Figure 8-32). If the brakes are applied with the turn signal switch in the neutral position, the diodes will allow voltage to flow to the CHMSL. If the turn signal switch is placed in the left-turn position, the left light must receive a pulsating voltage from the flasher. However, the steady voltage being applied to the right brake light would cause the left light to burn steady if the diode was not used. Diode 1 will block the voltage from the right lamp, preventing it from reaching the



**FIGURE 8-28** Brake light operation with the turn signals in the neutral position.



**FIGURE 8-29** Brake light operation with the turn signal in the left-turn position.

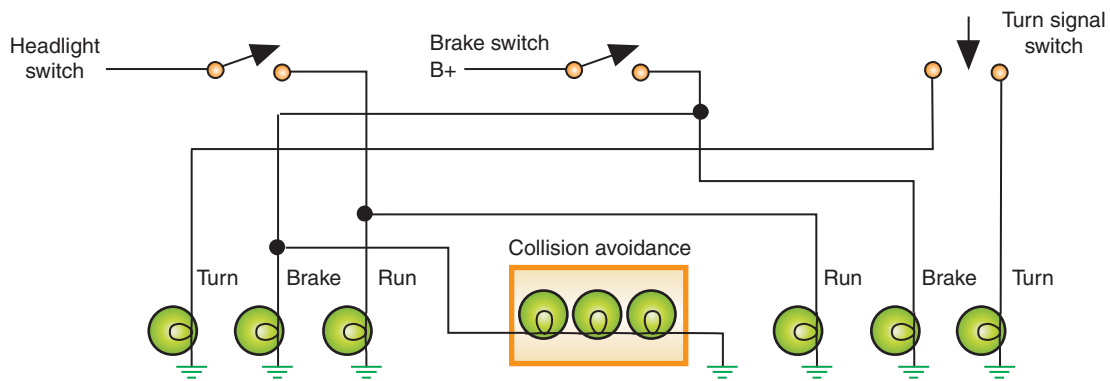


FIGURE 8-30 Wiring of a CHMSL in a three-bulb circuit.

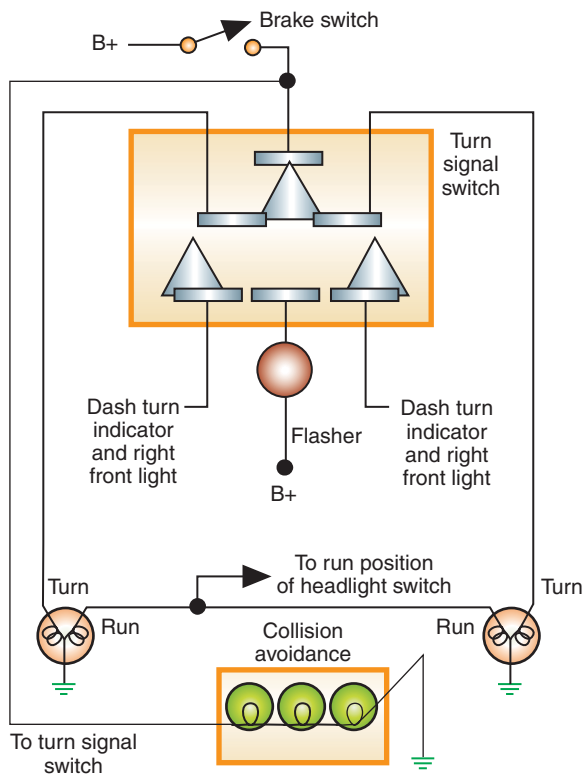


FIGURE 8-31 Wiring the CHMSL into the two-bulb circuit between the brake light switch and the turn signal.

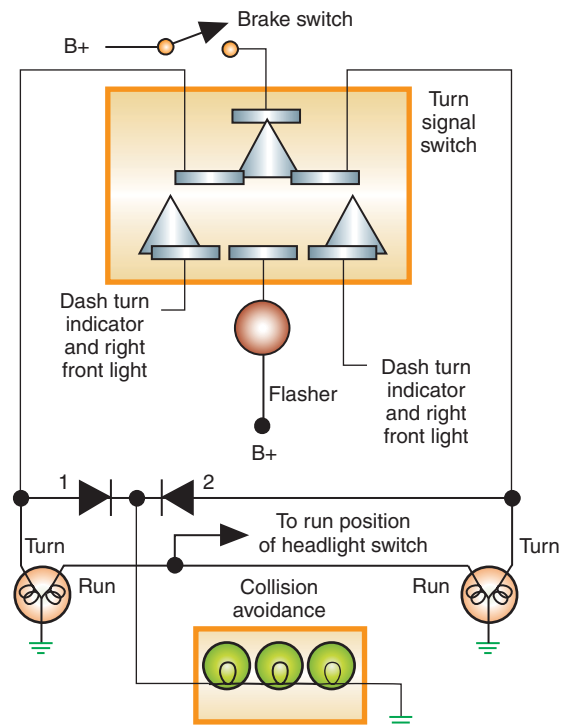


FIGURE 8-32 Two-bulb taillight circuit incorporating a CHMSL into the brake light system.

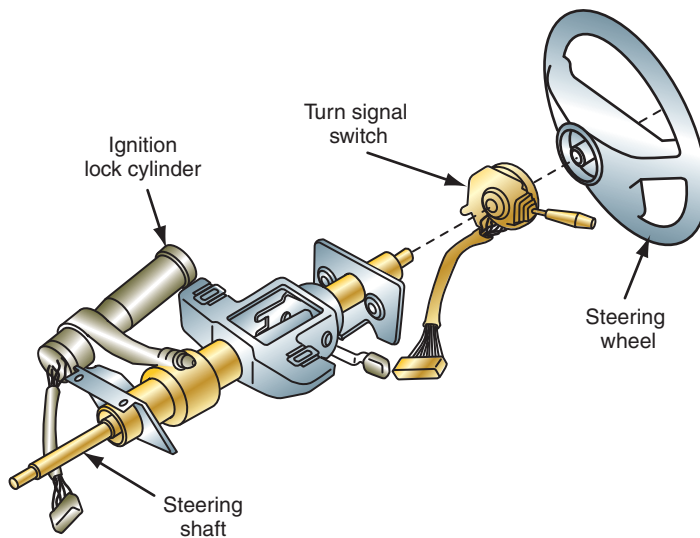
left light. Diode 2 will allow this voltage from the right brake light circuit to be applied to the CHMSL.

## Turn Signals

Turn signals are used to indicate the driver's intention to change direction or lanes. The driver will actuate a turn signal switch that is usually located in the steering column (Figure 8-33). In the neutral position, the contacts are opened, preventing current flow. When the driver moves the turn signal lever to indicate a left turn, the turn signal switch closes the contacts to direct voltage to the front and rear lights on the left side of the vehicle (Figure 8-34). When the turn signal switch is moved to indicate a right turn, the contacts are moved to direct voltage to the front and rear turn signal lights on the right side of the vehicle.

### Shop Manual

Chapter 8, page 330



**FIGURE 8-33** Typical turn signal switch location.

© Delmar/Cengage Learning

A **flasher** is used to open and close the turn signal circuit at a set rate. With the contacts closed, power flows from the flasher through the turn signal switch to the lamps. The flasher consists of a set of normally closed contacts, a bimetallic strip, and a coil heating element (Figure 8-35). These three components are wired in series. As current flows through the heater element, it increases in temperature, which heats the bimetallic strip. The strip then bends and opens the contact points. Once the points are open, current flow stops. The bimetallic strip cools and the contacts close again. With current flowing again, the process is repeated. Because the flasher is in series with the turn signal switch, this action causes the turn signal lights to turn on and off.

The hazard warning system is part of the turn signal system. It has been included on all vehicles sold in North America since 1967. All four turn signal lamps flash when the hazard warning switch is turned on. Depending on the manufacturer, a separate flasher can be used for the hazard lights than the one used for the turn signal lights. The operation of the hazard flasher is identical to that of the turn signal. The only difference is that the hazard flasher is capable of carrying the additional current drawn by all four turn signals. And, it receives its power source directly from the battery. Figure 8-36 shows the current flow through the hazard warning system.

## Neon Third Brake Lights

Some vehicles use neon lamps for rear high-mount brake lights. These lights are more energy efficient and turn on more quickly than the regular lights. Behind the third brake light lens is a single neon bulb. Since neon bulbs have no filament, the neon bulb should last much longer than a regular bulb.

The neon bulbs turn on within 3 milliseconds after being activated. Halogen lamps require 300 milliseconds. The importance of this quickness is that it gives the driver behind the vehicle an earlier warning to stop. This early warning can give the approaching driver 19 more feet (6 meters) for stopping when driving at 60 miles per hour (96 kmh).

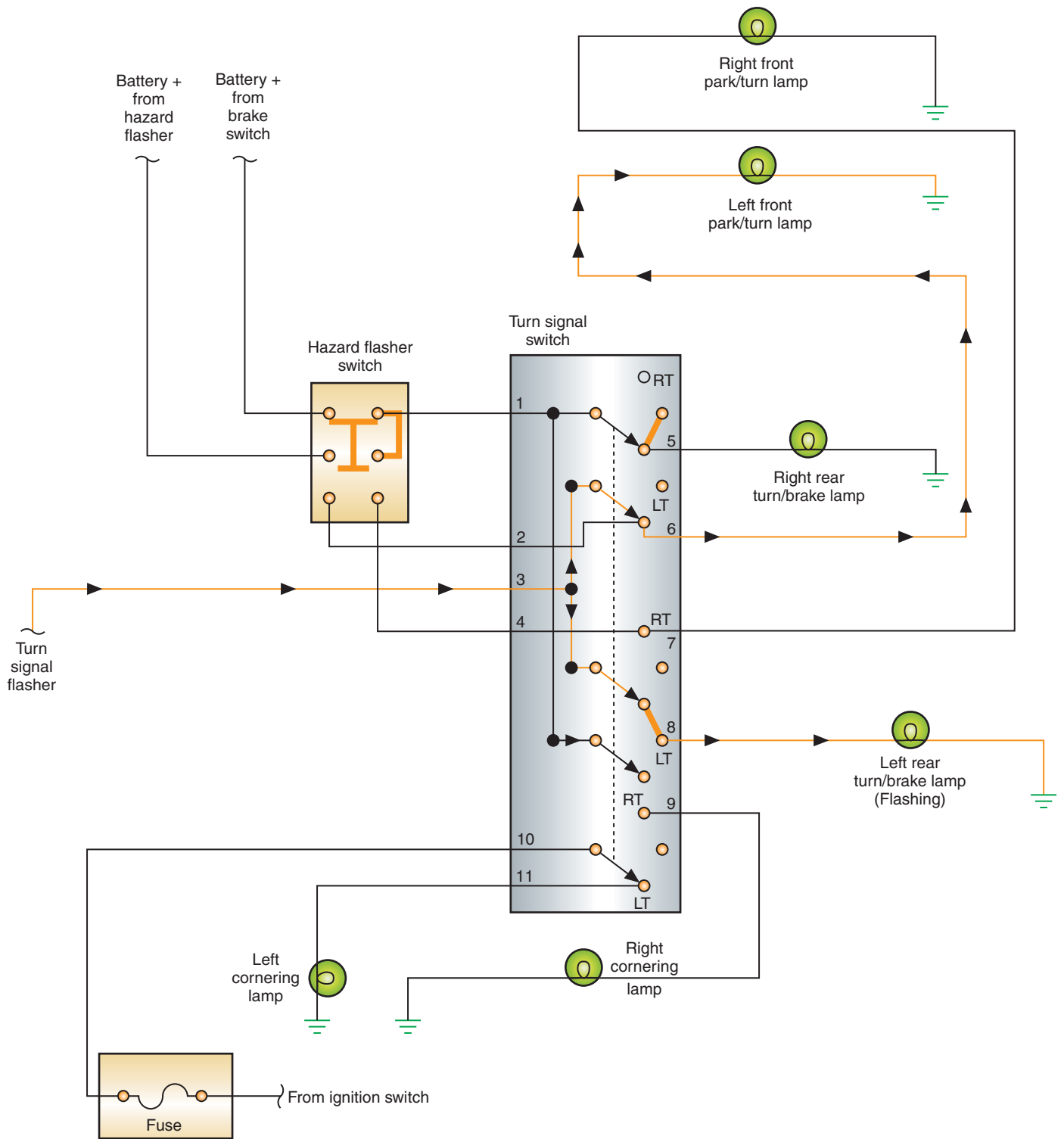
## LED Exterior Lighting

Many car manufacturers use LED lighting technology for several exterior lighting functions. The most common use of LEDs is in the CHMSL. Other uses include taillight assemblies (Figure 8-37), side marker lights, and turn-indicating outside mirrors. LEDs used in rear-lighting applications (especially the CHMSL) provide one means of increasing traffic safety. Driver reaction times in response to the brake light function is shorter for CHMSLs equipped

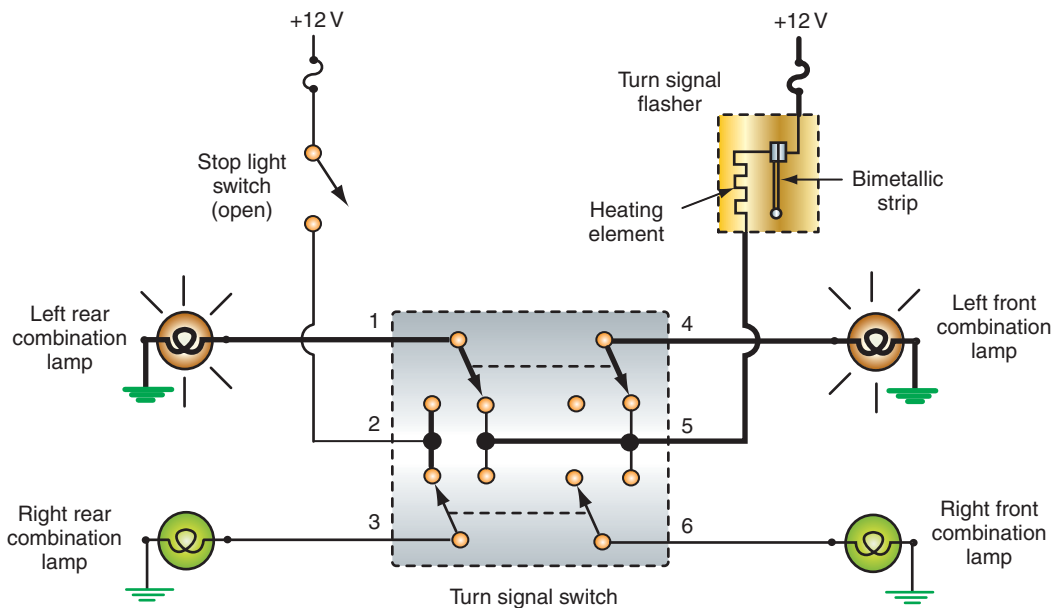
**Shop Manual**

Chapter 8, page 332





**FIGURE 8-34** Turn signal circuit with the switch in the left-turn position.



**FIGURE 8-35** The flasher uses a bimetallic strip and a heating coil to flash the turn signal lights.

© Delmar/Cengage Learning

with conventional incandescent bulbs than for those equipped with LEDs. This is due to the shorter LED illumination time of less than one millisecond. Another advantage of LED lighting is the extended life of the LED compared to a bulb.

An example of the use of LED technology in rear-lighting systems occurs in the Cadillac STS. Each tail lamp assembly has thirty points of illumination by using two vertical boards, each board consisting of fifteen LEDs. The CHMSL is approximately 1/2 inch (12 mm) thick and consists of seventy-eight points of illumination.

## Cornering Lights

**Cornering lights** are lamps that illuminate when the turn signals are activated. They burn steady when the turn signal switch is in a turn position to provide additional illumination of the road in the direction of the turn (Figure 8-38). Vehicles equipped with cornering lights have an additional set of contacts in the turn signal switch. These contacts operate the cornering light circuit only. The contacts can receive voltage from either the ignition switch or the headlight switch. If the ignition switch provides the power, the cornering lights will be activated any time the turn signals are used (Figure 8-39). If the contacts receive the voltage from the headlight switch, the cornering lights do not operate unless the headlight switch is in the PARK or HEADLIGHT position.

## Fog Lights

For increased safety when driving in snow, sleet, heavy rains, and heavy fog conditions, some vehicles are equipped with fog lights. Fog lights can also be installed as an after-market accessory. Headlights will reflect off heavy, dense fog and cause a white haze that can reduce visibility. Fog lights emit a specialized beam to penetrate through the snow, rain, or fog, providing the driver with a better and safer field of vision.

Fog lights are installed on each side of the vehicle, generally low on the front fascia. Due to their mounting location, fog lights illuminate below the normal line of sight. This minimizes the amount of reflected light, to help the driver see better.

Common fog light circuits use a relay (Figure 8-40). Also, most fog light circuits are wired so the fog lights will come on only if the headlight switch is in the PARK or Low beam positions.

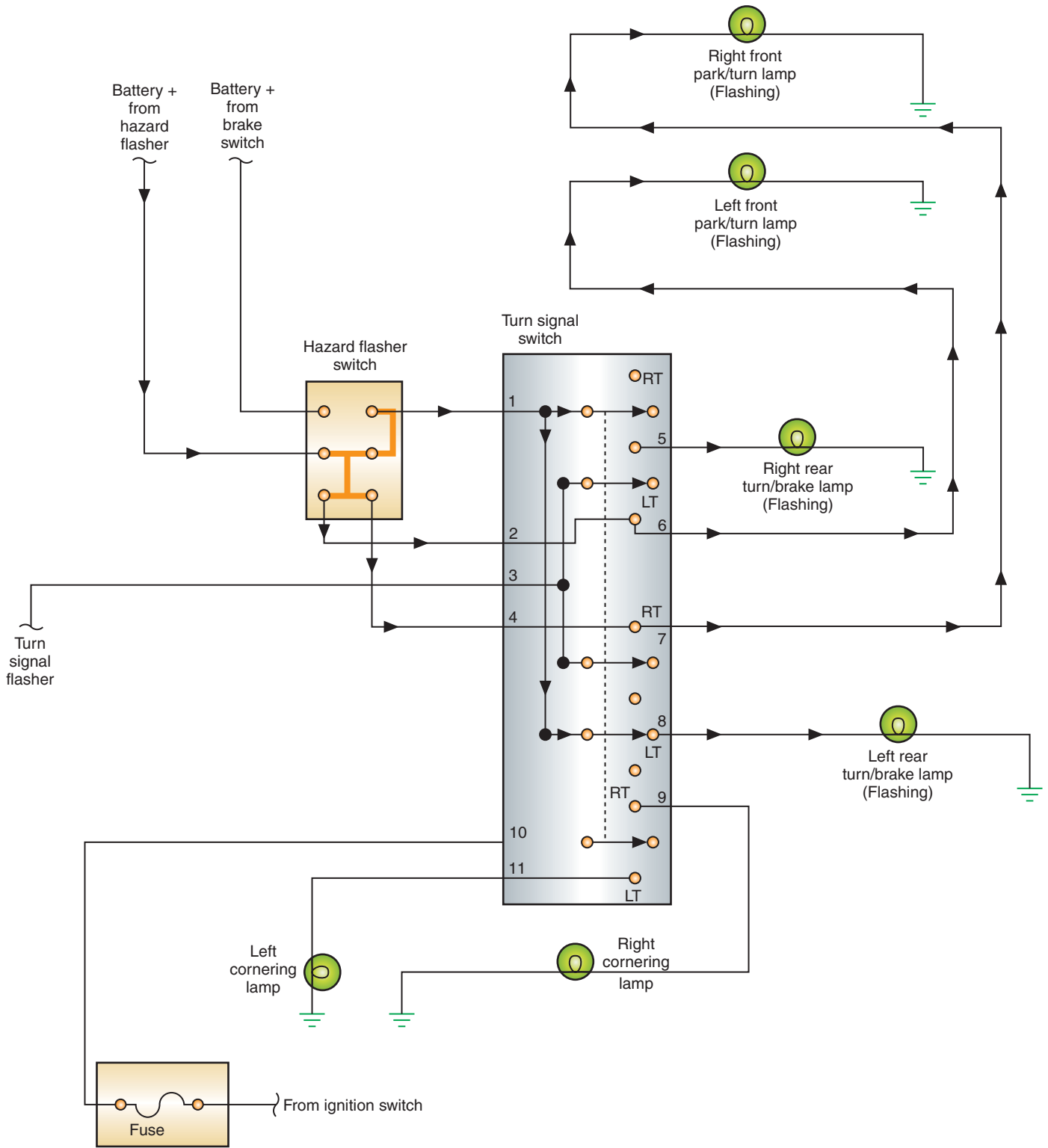


FIGURE 8-36 Current flow when the hazard warning system is activated.



© Delmar/Cengage Learning

**FIGURE 8-37** LED taillight assembly.



© Delmar/Cengage Learning

**FIGURE 8-38** Cornering lights are used to provide additional illumination during turns.

## Back-up Lights

All vehicles sold in North America after 1971 are required to have back-up lights. Back-up lights illuminate the road behind the vehicle and warn other drivers and pedestrians of the driver's intention to back up. Figure 8-41 illustrates a back-up light circuit. Power is supplied through the ignition switch when it is in the RUN position. When the driver shifts the transmission into reverse, the back-up light switch contacts are closed and the circuit is completed.

Many vehicles equipped with automatic transmissions incorporate the back-up light switch into the neutral safety switch. Most manual transmissions are equipped with a separate switch. Either style of switch can be located on the steering column, on the floor console, or on the transmission (Figure 8-42). Depending on the type of switch used, there may be a means of adjusting the switch to assure that the lights are not on when the vehicle is in a forward gear selection.

## Side Marker Lights

Side marker lights are installed on all vehicles sold in North America since 1969. These lamps permit the vehicle to be seen when entering a roadway from the side. This also provides a



### A BIT OF HISTORY

The 1921 Wills-St. Claire was the first car to display a backup lamp.



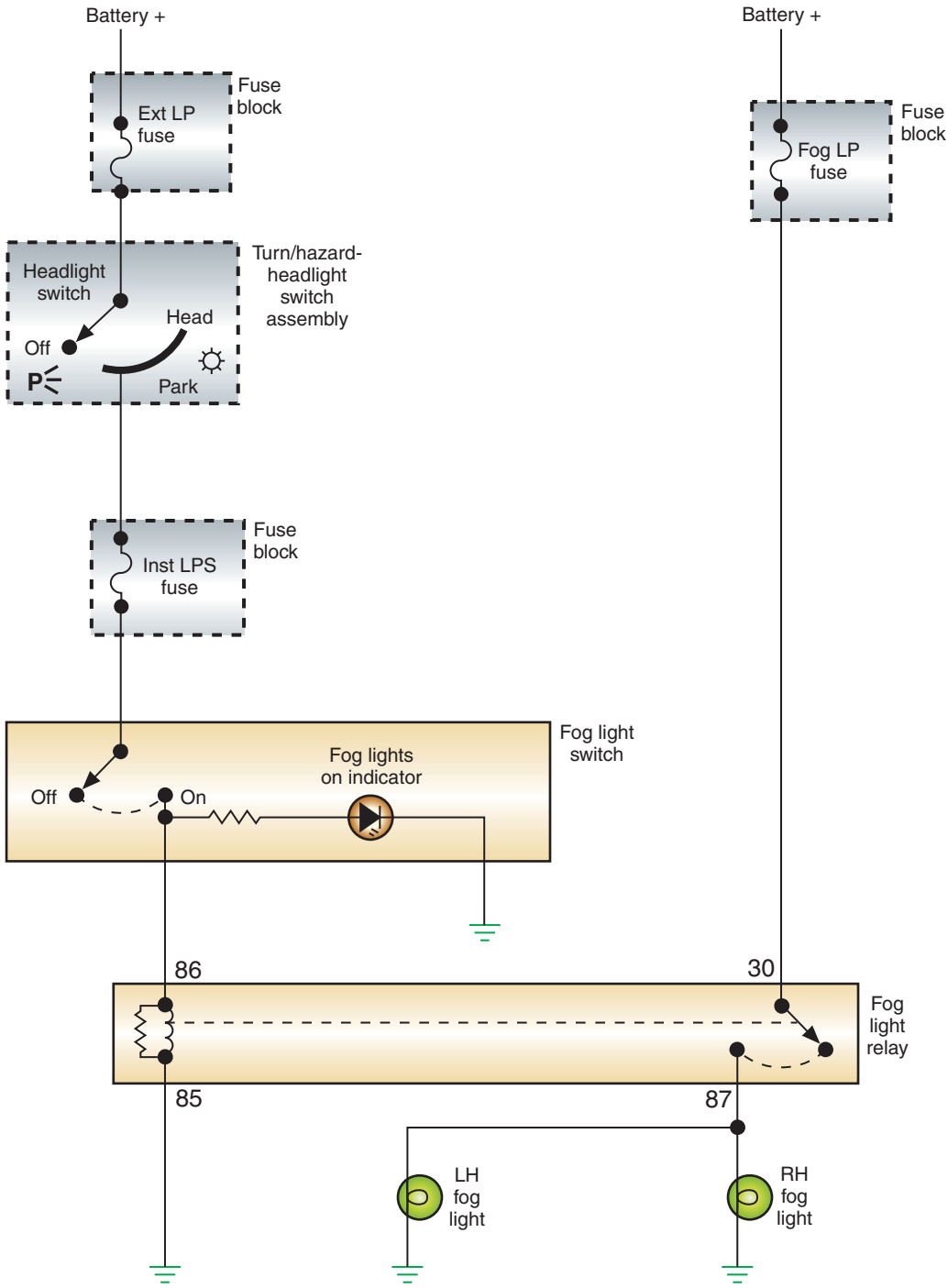
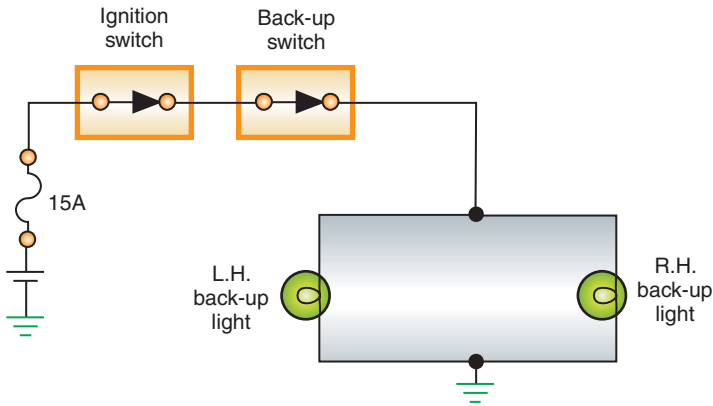


FIGURE 8-40 Typical fog light circuit.

© Delmar/Cengage Learning





**FIGURE 8-41** Backup light circuit.



**FIGURE 8-42** A combination backup and neutral safety switch installed on an automatic transmission.

means for other drivers to determine vehicle length. The front side marker light lens must be amber and the rear lens must be red. Vehicles that use wrap-around headlight and taillight assemblies also use this lens for the side marker lights (Figure 8-43). Vehicles that surpass certain length and height limits are also required to have clearance lights that face both to the front and rear of the vehicle.

The common method of wiring the side marker lights is in parallel with the parking lights. Wired in this manner, the side marker lights would illuminate only when the headlight switch was in the PARK or HEADLIGHT position.

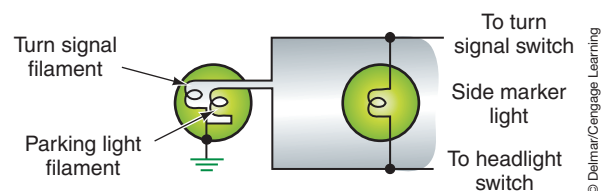
Many vehicle manufacturers use a method of wiring in the side marker lights so that they flash when the turn signals are activated. The side marker light is wired across the parking light and turn signal light (Figure 8-44). If the parking lights are on, voltage is applied to the side marker light from the parking light circuit. Ground for the side marker light is provided through the turn signal filament. Because of the large voltage drop across the side marker lamp, the turn signal bulb will barely illuminate. In this condition, the side marker light stays on constantly (Figure 8-45).

If the parking lights are off and the turn signal is activated, the side marker light receives its voltage source from the turn signal circuit. Ground for the side marker light is provided through the parking light filament. The voltage drop over the side marker light is so high that the parking light will not illuminate. The side marker light will flash with the turn signal light (Figure 8-46).

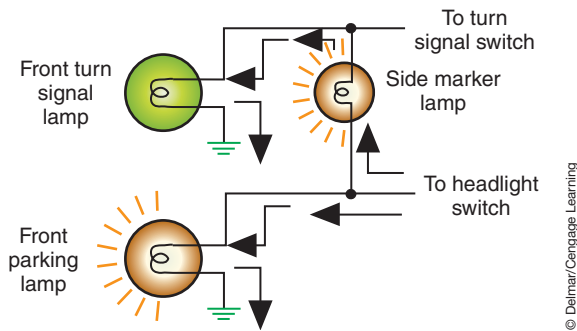
If the turn signal is activated while the parking lights are illuminated, the side marker light will flash alternately with the turn signal light. When both the turn signal light and the parking light are on, there is equal voltage applied to both sides of the side marker light. There is no voltage potential across the bulb, so the light does not illuminate (Figure 8-47). The turn signal light turns off as a result of the flasher opening. Then the turn signal light filament



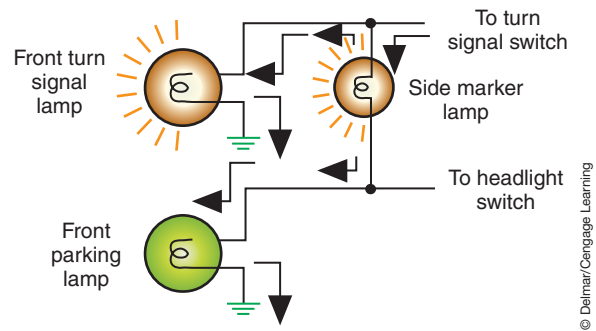
**FIGURE 8-43** Wrap-around headlights serve as side marker lights.



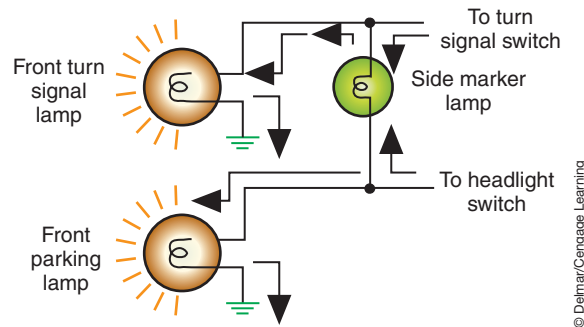
**FIGURE 8-44** A side marker light wired across two circuits.



**FIGURE 8-45** Current flow to the side marker light with the parking light on.



**FIGURE 8-46** Side marker operation with the turn signal switch activated.



**FIGURE 8-47** Side marker light with the turn signal light and parking light on.

provides a ground path and the side marker light comes on. The side marker light will stay on until the flasher contacts close to turn on the turn signal light again.

## INTERIOR LIGHTS

Interior lighting includes courtesy lights, map lights, and instrument panel lights.

### Courtesy Lights

**Courtesy lights** illuminate the vehicle's interior when the doors are open. Courtesy lights operate from the headlight and door switches and receive their power source directly from a fused battery connection. The switches can be either ground switch circuit (Figure 8-48) or insulated switch circuit design (Figure 8-49). In the insulated switch circuit, the switch is used as the power relay to the lights. In the grounded switch circuit, the switch controls the grounding portion of the circuit for the lights. The courtesy lights may also be activated by the headlight switch. When the headlight switch knob is turned to the extreme counterclockwise position, the contacts in the switch close and complete the circuit.

### Reading and Map Lights

Individual switches and controls to allow passengers in the vehicle to turn on individual lights are incorporated within most courtesy light systems (refer to Figure 8-49). The system shown has individual two-position switches that allow the passenger to turn on a light. When the switch is pressed, it completes the circuit to ground for that light only.

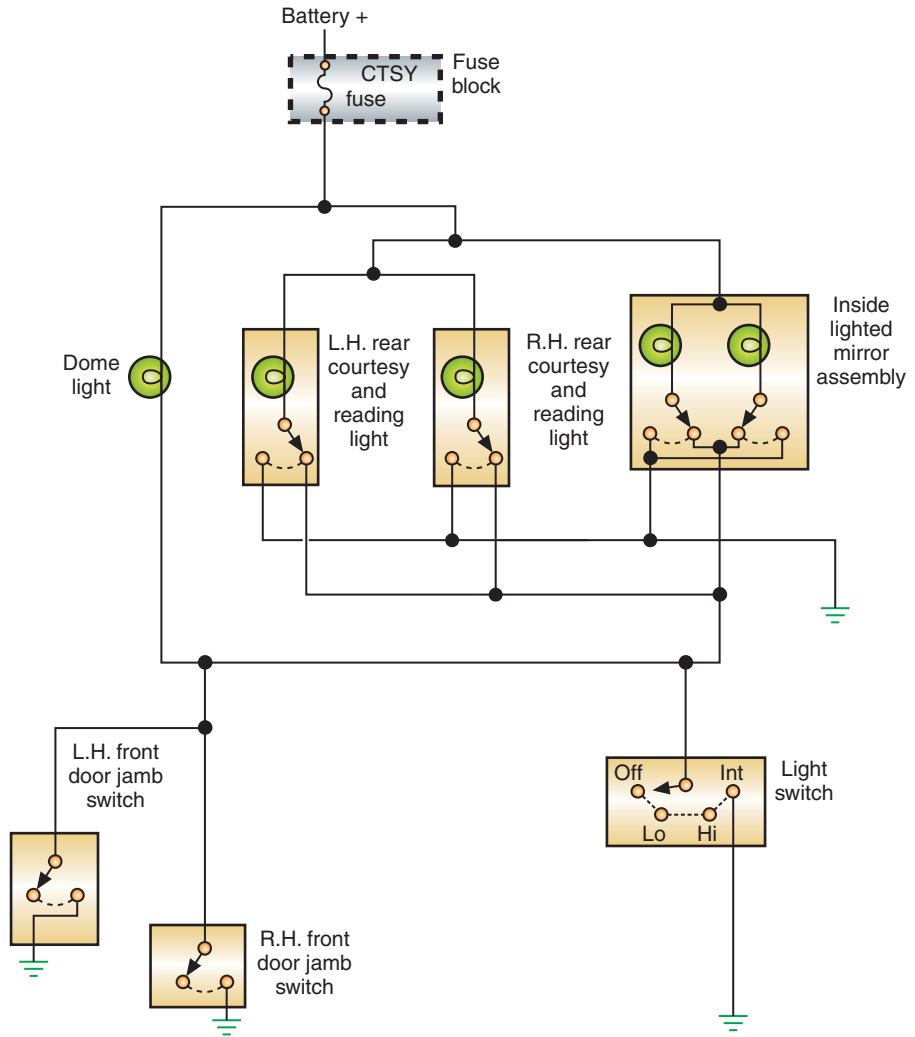
**Shop Manual**

Chapter 8, page 335



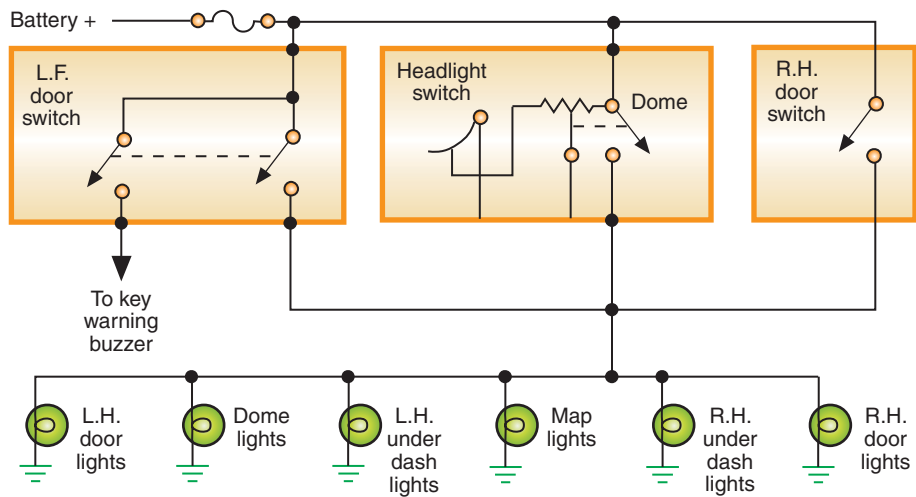
## A BIT OF HISTORY

In 1913, the Spaulding touring car had such luxuries as four seats with folding backs, air mattresses, and electric reading lamps.



© Delmar/Cengage Learning

FIGURE 8-48 Courtesy lights using ground side switches.



© Delmar/Cengage Learning

FIGURE 8-49 Courtesy lights using insulated side switches.

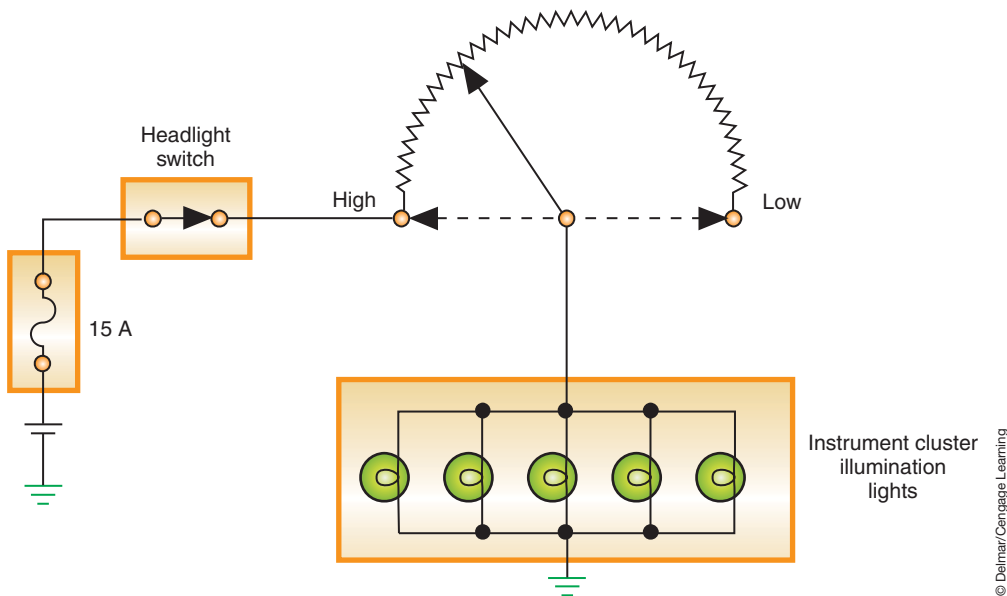


FIGURE 8-50 A rheostat controls the brightness of the instrument panel lights.

## Instrument Cluster and Panel Lights

Consider the following three types of lighting circuits within the instrument cluster:

1. **Warning lights** alert the driver to potentially dangerous conditions such as brake failure or low oil pressure.
2. **Indicator lights** include turn signal indicators.
3. **Illumination lights** provide indirect lighting to illuminate the instrument gauges, speedometer, heater controls, clock, ashtray, radio, and other controls.

The power source for the instrument panel lights is provided through the headlight switch. The contacts are closed when the headlight switch is located in the PARK or HEADLIGHT position. The current must flow through a variable resistor (rheostat) that is either a part of the headlight switch or a separate dial on the dash. The resistance of the rheostat is varied by turning the knob. By varying the resistance, changes in the current flow to the lamps control the brightness of the lights (Figure 8-50).

## SUMMARY

- The most commonly thought of light circuit is the headlights. But there are many lighting systems in the vehicle.
- Different types of lamps are used to provide illumination for the systems. The lamp may be either a single-filament bulb that performs a single function, or a double-filament bulb that performs several functions.
- The headlight lamps can be one of four designs: standard sealed beam, halogen sealed beam, composite, or high-intensity discharge (HID).
- The headlight filament is located on a reflector that intensifies the light, which is then directed through the lens. The lens is designed to change the circular light pattern into a broad, flat light beam. Placement of the filament in the reflector provides for low- and high-beam light patterns.
- Some manufacturers use concealed headlights to improve the aerodynamics of the vehicle. The concealed headlight doors can operate from vacuum or by electrically controlled motors. Some systems incorporate the use of IC chips into the concealed headlight door control.

Shop Manual

Chapter 8, page 338

## TERMS TO KNOW

Bi-xenon headlamps  
 Composite headlight  
 Concealed headlight  
 Courtesy lights

## TERMS TO KNOW

(continued)

Dimmer switch

Double-filament lamp

Flasher

Halogen

High-intensity

discharge (HID)

Incandescence

Lamp

Prisms

Sealed-beam

Vaporized aluminum

## SUMMARY

- In addition to the headlight system, the lighting systems include:
  - Stop lights.
  - Turn signals.
  - Hazard lights.
  - Parking lights.
  - Taillights.
  - Back-up lights.
  - Side marker lights.
  - Courtesy lights.
  - Instrument panel lights.
- The headlight switch can be used as the control of many of these lighting systems. Most headlight switches have a circuit breaker that is an integral part of the switch. The circuit breaker provides protection of the headlight system without totally disabling the headlight operation if a circuit overload is present.
- A rheostat is used in conjunction with the headlight switch to control the brightness of the instrument panel illumination lights.

## REVIEW QUESTIONS

### Short-Answer Essays

1. What lighting systems are controlled by the headlight switch?
2. How is the brightness of the instrument cluster lamps controlled?
3. What is CHMSL?
4. What is the purpose of the lamp filament?
5. What three lighting circuits are incorporated within the instrument cluster?
6. List and describe the four types of headlight lamps used.
7. Describe the influence that the turn signal switch has on the operation of the brake lights in a two-bulb taillight assembly.
8. What is the purpose of the diodes on some CHMSL circuits?
9. How are most cornering light circuits wired to allow the cornering light to be on steady when the turn signal switch is activated?
10. Describe the purpose of bi-xenon headlights.

### Fill in the Blanks

1. When today's technician performs repairs on the lighting systems, the repairs must meet at least two requirements: They must assure vehicle \_\_\_\_\_ and meet all \_\_\_\_\_.
2. A \_\_\_\_\_ is a device that produces light as a result of current flow through a \_\_\_\_\_.
3. \_\_\_\_\_ redirect the light beam and create a broad, flat beam.
4. The \_\_\_\_\_ controls most of the vehicle's lighting systems.
5. The \_\_\_\_\_ provides the means for the driver to select either high- or low-beam operation.
6. The complete headlight circuit consists of the \_\_\_\_\_, \_\_\_\_\_, \_\_\_\_\_, \_\_\_\_\_, and the \_\_\_\_\_.
7. The headlight doors of a concealed system can be controlled by either \_\_\_\_\_ or by \_\_\_\_\_.
8. On vehicles equipped with cornering lights, the turn signal switch has an additional set of \_\_\_\_\_ that operate the cornering light circuit only.
9. Most limit switches operate off of a \_\_\_\_\_ on the motor.
10. In most vehicles equipped with automatic transmissions, the back-up light switch is part of the \_\_\_\_\_.

Most manual transmissions are equipped with a \_\_\_\_\_ switch.

## MULTIPLE CHOICE

- In the two-bulb taillight assembly:
  - The brake lights use the high-intensity filament of the taillight bulb.
  - The current to the brake lights flows through the turn signal switch.
  - All of the above.
  - None of the above.
- In a composite headlight:
  - The bulb is replaceable.
  - A cracked lens will prevent lamp operation.
  - All of the above
  - None of the above.
- Current to the brake light switch usually comes from the:
  - Ignition switch feed.
  - Headlight switch feed.
  - Turn signal switch feed.
  - Direct battery feed.
- Which of the following statements about the turn signal circuit is NOT correct?
  - The dimmer switch is not a part of the circuit.
  - Most flashers use a bimetallic strip to open and close the circuit.
  - The turn signals operate only when the neutral safety switch is open.
  - The turn signal switch provides the means for lighting brake lights when the turn signals are operating.
- The turn signal system is being discussed.

*Technician A* says there is a separate flasher unit used for the left and the right turn signals.

*Technician B* says on most vehicles, the flasher unit is located in the lamp socket.

Who is correct?

  - A only
  - B only
  - Both A and B
  - Neither A nor B
- The concealed headlight system is being discussed.

*Technician A* says the system can use vacuum to operate the doors.

*Technician B* says the system can use electric motors to operate the doors.

Who is correct?

  - A only
  - B only
  - Both A and B
  - Neither A nor B
- The CHMSL circuit is being discussed.

*Technician A* says the diodes are used to assure proper turn signal operation.

*Technician B* says the diodes are used to prevent radio static when the brake light is activated.

Who is correct?

  - A only
  - B only
  - Both A and B
  - Neither A nor B
- Which statement about the cornering light system is NOT correct?
  - The cornering lights use an additional set of contacts in the turn signal switch.
  - The cornering lights can receive voltage from the ignition switch.
  - The cornering lights can receive voltage from the headlight switch.
  - The cornering lights can operate only if the vehicle speed sensor input indicates speeds over 3 mph (4.8 kph).
- Technician A* says the side marker lights can be wired to flash with the turn signals.

*Technician B* says wrap-around lenses can be used for side marker lights.

Who is correct?

  - A only
  - B only
  - Both A and B
  - Neither A nor B
- Which of the following best describes the function of the bi-xenon headlight system?
  - Uses double filament headlights to provide the high beam output.
  - Use a chamber filled with multiple xenon gases that are ignited at different temperatures to provide high beam and low beam operation.
  - Uses multiple chamber of xenon gas that are ignited based on dimmer switch position. One chamber is for low beam, and both chambers are ignited for high beam.
  - None of the above.



## Chapter 9

# INTRODUCTION TO THE BODY COMPUTER

**UPON COMPLETION AND REVIEW OF THIS CHAPTER, YOU SHOULD BE ABLE TO UNDERSTAND AND DESCRIBE.**

- The basic functions of the computer.
- The principle of analog and digital voltage signals.
- The principle of computer communications.
- The basics of logic gate operation.
- The basic function of the microprocessor.
- The basic method by which the microprocessor is able to make determinations.
- The differences in memory types.
- The operation of low-side and high-side drivers.
- The operation of common output actuators.

### INTRODUCTION

A computer is an electronic device that stores and processes data. It is also capable of controlling other devices. This chapter introduces the basic theory and operation of the digital computer used to control many of the vehicle's accessories. The use of computers on automobiles has expanded to include control and operation of several functions, including climate control, lighting circuits, cruise control, antilock braking, electronic suspension systems, and electronic shift transmissions. Some of these are functions of what is known as a body computer module (BCM). Some body computer-controlled systems include direction lights, rear window defoggers, illuminated entry, intermittent wipers, and other systems once thought of as basic.

**AUTHOR'S NOTE:** When computer controls were first installed on the automobile, the aura of mystery surrounding these computers was so great that some technicians were afraid to work on them. Most technicians coming into the field today have grown up around computers and the fear is not as great. Regardless of your comfort level with computers, knowledge is key to understanding their function. Although it is not necessary to understand all of the concepts of computer operation in order to service the systems they control, knowledge of the digital computer will help you feel more comfortable when working on these systems.

### COMPUTER FUNCTIONS

A computer processes the physical conditions that represent information (data). The operation of the computer is divided into four basic functions:

1. *Input:* A voltage signal sent from an input device. This device can be a sensor or a switch activated by the driver or technician.

2. **Processing:** The computer uses the input information and compares it to programmed instructions. The logic circuits process the input signals into output demands.
3. **Storage:** The program instructions are stored in an electronic memory. Some of the input signals are also stored for later processing.
4. **Output:** After the computer has processed the sensor input and checked its programmed instructions, it will put out control commands to various output devices. These output devices may be the instrument panel display or a system actuator. The output of one computer can also be used as an input to another computer.

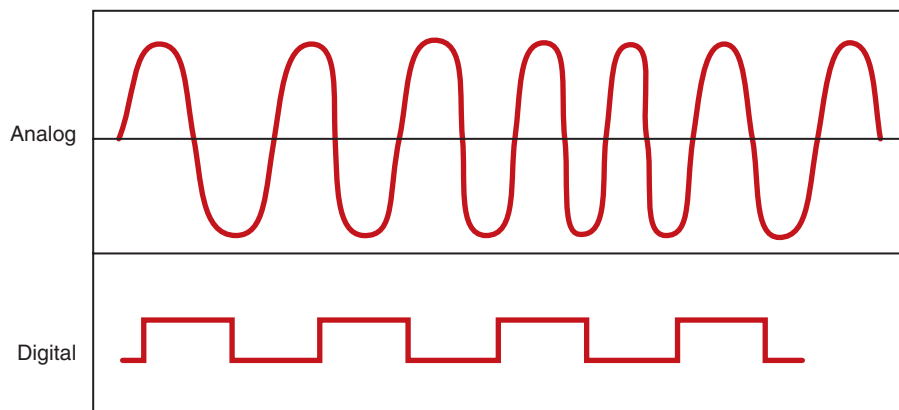
Understanding these four functions will help today's technician organize the troubleshooting process. When a system is tested, the technician will be attempting to isolate the problem to one of these functions.

## ANALOG AND DIGITAL PRINCIPLES

Remembering the basics of electricity, voltage does not flow through a conductor; current flows and voltage is the pressure that “pushes” the current. However, voltage can be used as a signal; for example, difference in voltage levels, frequency of change, or switching from positive to negative values can be used as a signal.

The computer is capable of reading only voltage signals. A **program** is a set of instructions the computer must follow to achieve desired results. The program used by the computer is “burned” into integrated circuit (IC) chips using a series of numbers. These numbers represent various combinations of voltages that the computer can understand. The voltage signals to the computer can be either analog or digital. Many of the inputs from the sensors are analog variables. For example, ambient temperature sensors do not change abruptly. The temperature varies in infinite steps from low to high. The same is true for several other inputs such as engine speed, vehicle speed, fuel flow, and so on.

Compared to an analog voltage representation, digital voltage patterns are square-shaped because the transition from one voltage level to another is very abrupt (Figure 9-1). A digital signal is produced by an on/off or high/low voltage. The simplest generator of a digital signal is a switch (Figure 9-2). If 5 volts are applied to the circuit, the voltage sensor will read 5 volts (a high-voltage value) when the switch is open. Closing



**FIGURE 9-1** Analog voltage signals are constantly variable. Digital voltage patterns are either on or off. Digital signals are referred to as a square sine wave.



## A BIT OF HISTORY

“Computer” was originally a job title, so the first computers were actual people. The job title of computer was used to describe those people that performed the repetitive calculations required to compute navigational tables, tide charts, and planetary positions. Electronic computers were given this name because they performed the work that had previously been assigned to people. People who had the job title of computer, relied upon a tool known as the abacus to aid their memory while performing the calculations. Since people who worked as computers would often suffer from boredom that resulted in carelessness and mistakes inventors started searching for ways to mechanize this task.

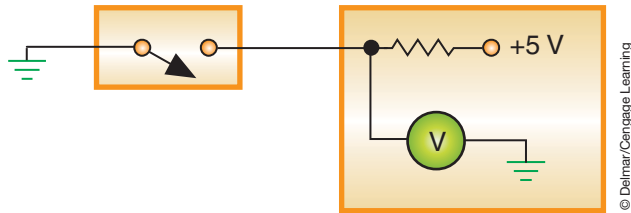
During World War II, the United States had battleships capable of firing shells weighing over a ton at targets up to 25 miles away. To determine the trajectory of the shells, physicists provided the equations but solving these equations using human computers proved to be labor intensive. In order to



## A BIT OF HISTORY

(continued)  
 solve its problems, the U.S. military invested in means of automating these computations. An early success was a computer built from a partnership between Harvard and IBM in 1944 known as the Harvard Mark I. The Harvard Mark I was the first programmable digital computer made in the United States. However, the Harvard Mark I was not exclusively electronic and was constructed out of switches, relays, rotating shafts, and clutches. The computer was 8 feet tall and 51 feet long and weighed 5 tons. It used 500 miles of wire, and required a 50 ft rotating shaft that ran its length that was turned by a 5 horsepower electric motor. The Harvard Mark I contained three quarters of a million components, yet it was capable of storing only 72 numbers. Today's home computers can store 30 million numbers in RAM and another 10 billion numbers on their hard disk. The Mark I ran non-stop for 15 years.

Grace Hopper was one of the primary programmers for the Harvard Mark I and



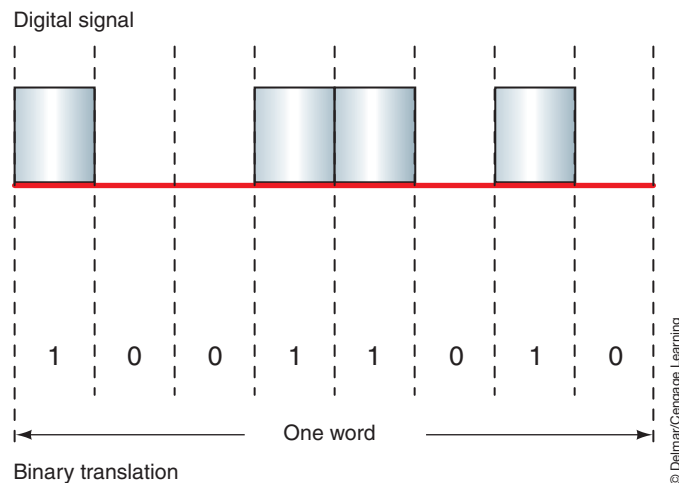
**FIGURE 9-2** Simplified voltage sensing circuit that indicates if the switch is opened or closed.

the switch will result in the voltage sensor reading close to 0 volts. This measuring of voltage drops sends a digital signal to the computer. The voltage values are represented by a series of digits, which create a **binary code**. Binary code is represented by the numbers 1 and 0. Any number and word can be translated into a combination of binary 1's and 0's.

## Binary Numbers

A transistor that operates as a relay is the basis of the digital computer. As the input signal switches from off to on, the transistor output switches from cutoff to saturation. The on and off output signals represent the binary digits 1 and 0.

The computer converts the digital signal into binary code by translating voltages above a given value to 1 and voltages below a given value to 0. As shown (Figure 9-3), when the switch is open and 5 volts are sensed, the voltage value is translated into a 1 (high voltage). When the switch is closed, lower voltage is sensed and the voltage value is translated into a 0. Each 1 or 0 represents one bit of information.



**FIGURE 9-3** Each binary 1 and 0 is one bit of information. Eight bits equal one byte.



## A BIT OF HISTORY

(continued)  
is said to be the founder of the first computer “bug.” A dead moth had gotten into the Harvard Mark I and its wings blocked the reading of the holes in the paper tape.

Decimal number	Binary number code 8 4 2 1	Binary to decimal conversion
0	0000	$= 0 + 0 = 0$
1	0001	$= 0 + 1 = 1$
2	0010	$= 2 + 0 = 2$
3	0011	$= 2 + 1 = 3$
4	0100	$= 4 + 0 = 4$
5	0101	$= 4 + 1 = 5$
6	0110	$= 4 + 2 = 6$
7	0111	$= 4 + 2 + 1 = 7$
8	1000	$= 8 + 0 = 8$
9	1001	$= 8 + 1 = 9$

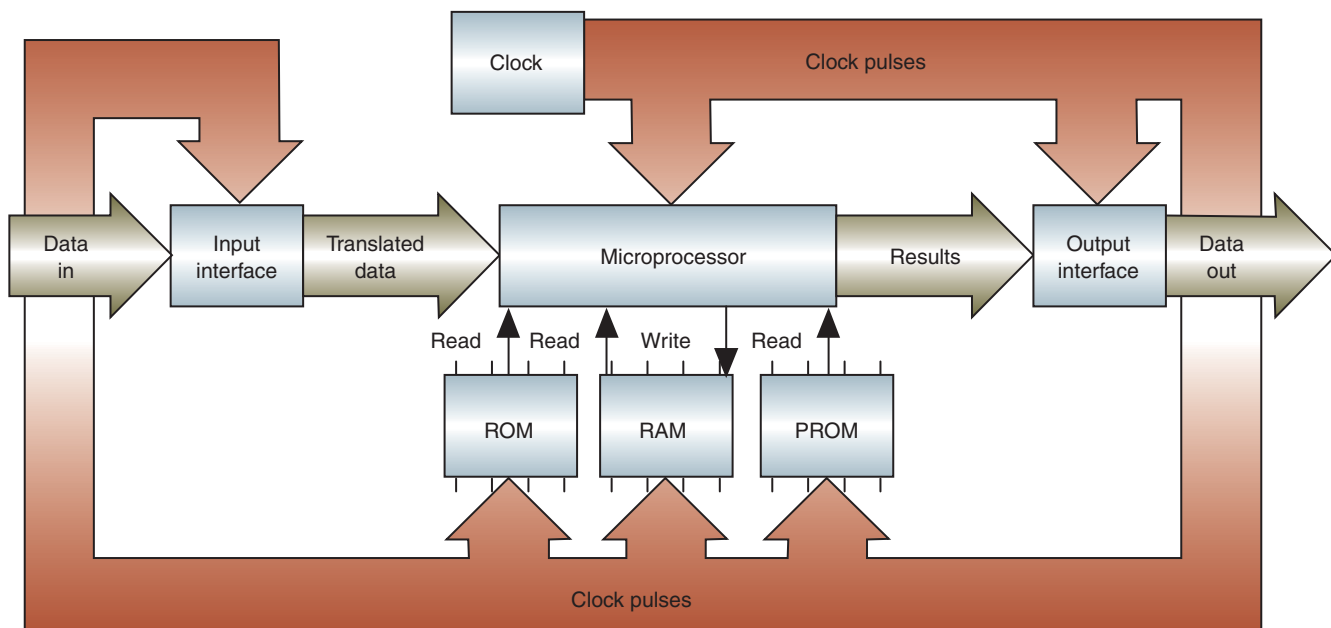
© Delmar/Cengage Learning

FIGURE 9-4 Binary number code conversion to base 10 numbers.

In the binary system, whole numbers are grouped from right to left. Because the system uses only two digits, the first portion must equal a 1 or a 0. To write the value of 2, the second position must be used. In binary, the value of 2 would be represented by 10 (one two and zero ones). To continue, a 3 would be represented by 11 (one two and one one). Figure 9-4 illustrates the conversion of binary numbers to digital base ten numbers. If a thermistor is sensing 150 degrees, the binary code would be 10010110. If the temperature increases to 151 degrees, the binary code changes to 10010111.

The computer contains a crystal oscillator or **clock circuit** that delivers a constant time pulse. The clock is a crystal that electrically vibrates when subjected to current at certain voltage levels. As a result, the chip produces a very regular series of voltage pulses. The clock maintains an orderly flow of information through the computer circuits by transmitting one **bit** of binary code for each pulse (Figure 9-5). In this manner, the computer is capable of distinguishing between the binary codes such as 101 and 1001.

A **bit** is a 0 or a 1 of the binary code. Eight bits is called a byte.



© Delmar/Cengage Learning

FIGURE 9-5 Interaction of the main components of the computer. All of the components monitor clock pulses.

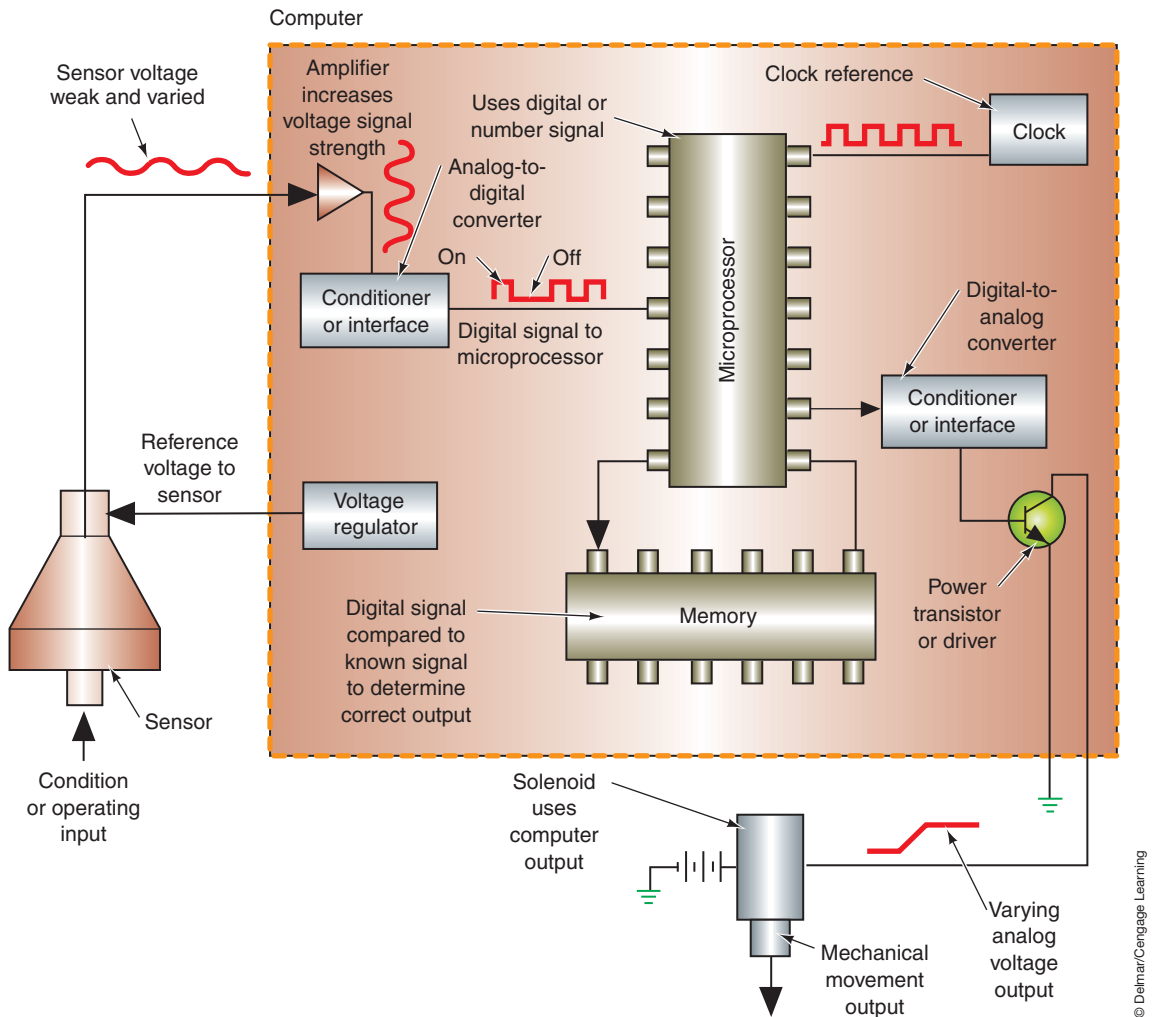
## Signal Conditioning and Conversion

The input and/or output signals may require conditioning in order to be used. This conditioning may include amplification and/or signal conversion.

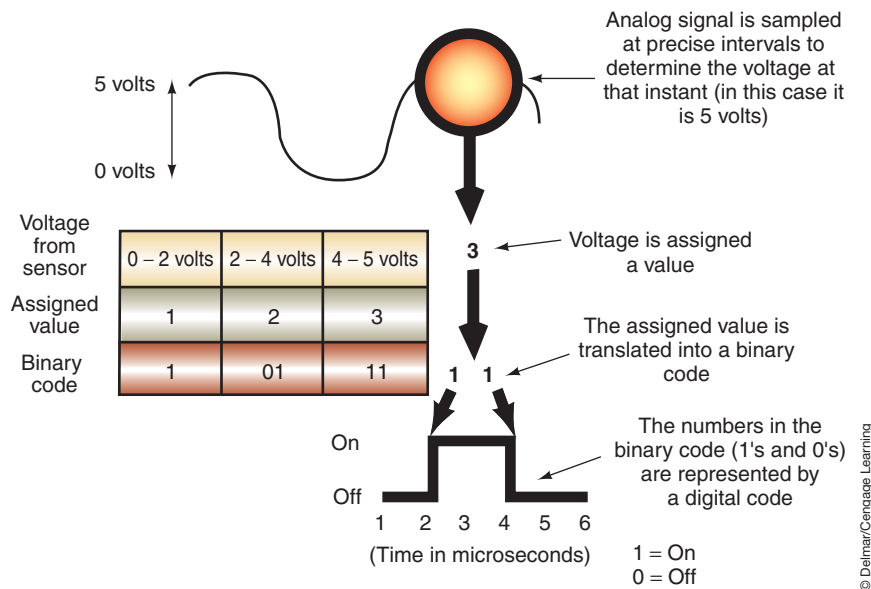
Some input sensors produce a very low-voltage signal of less than 1 volt. This signal also has an extremely low-current flow. Therefore, this type of signal must be amplified, or increased, before it is sent to the microprocessor. This amplification is accomplished by the amplification circuit in the input conditioning chip inside the computer (Figure 9-6).

For the computer to receive information from the sensor and give commands to actuators, it requires an **interface**. The computer will have two interface circuits: input and output. An interface is used to protect the computer from excessive voltage levels and to translate input and output signals. The digital computer cannot accept analog signals from the sensors and requires an input interface to convert the analog signal to digital. The analog to digital (A/D) converter continually scans the analog input signals at regular intervals. For example, if the A/D converter scans the TPS signal and finds the signal at 5 volts, the A/D converter assigns a numeric value to this specific voltage. Then the A/D converter changes this numeric value to a binary code (Figure 9-7).

Also, some of the controlled actuators may require an analog signal. In this instance, an output digital to analog (D/A) converter is used.



**FIGURE 9-6** Amplification and interface circuits in the computer. The amplification circuit boosts the voltage and conditions it. The interface converts analog inputs into digital signals. The digital-to-analog converter changes the output from digital to analog.



**FIGURE 9-7** The A/D converter assigns a numeric value to input voltages and changes this numeric value to a binary code.

## MICROPROCESSOR

The **microprocessor ( $\mu\text{P}$ )** is the brain of the computer. The  $\mu\text{P}$  is constructed of thousands of transistors that are placed on a small chip. The  $\mu\text{P}$  brings information into and out of the computer's memory. The input information is processed in the  $\mu\text{P}$  and checked against the program in memory. The  $\mu\text{P}$  also checks memory for any other information regarding programmed parameters. The information obtained by the  $\mu\text{P}$  can be altered according to the program instructions. The program may have the  $\mu\text{P}$  apply logic decisions to the information. Once all calculations are made, the  $\mu\text{P}$  will deliver commands to make the required corrections or adjustments to the operation of the controlled system.

The program guides the microprocessor in decision making. For example, the program may inform the microprocessor when sensor information should be retrieved and then tell the microprocessor how to interpret this information. Finally, the program guides the microprocessor regarding the activation of output control devices such as relays and solenoids. The various memories contain the programs and other vehicle data that the microprocessor refers to as it performs calculations. As the  $\mu\text{P}$  performs calculations and makes decisions, it works with the memories by either reading or writing information to them.

The  $\mu\text{P}$  has several main components (Figure 9-8). The registers used include the accumulator, the data counter, the program counter, and the instruction register. The control unit implements the instructions located in the instruction register. The arithmetic logic unit (ALU) performs the arithmetic and logic functions.

## COMPUTER MEMORY

The computer requires a means of storing both permanent and temporary memory. The memories contain many different locations. These locations can be compared to file folders in a filing cabinet, with each location containing one piece of information. An address is assigned to each memory location. This address may be compared to the lettering or numbering arrangement on file folders. Each address is written in a binary code, and these codes are numbered sequentially beginning with 0.

While the engine is running, the engine computer receives a large quantity of information from a number of sensors. The computer may not be able to process all this information immediately. In some instances, the computer may receive sensor inputs that the computer

The terms *microprocessor* and *central processing unit* are basically interchangeable.

The terms *ROM*, *RAM*, and *PROM* are used fairly consistently in the computer industry. However, the names vary between automobile manufacturers.



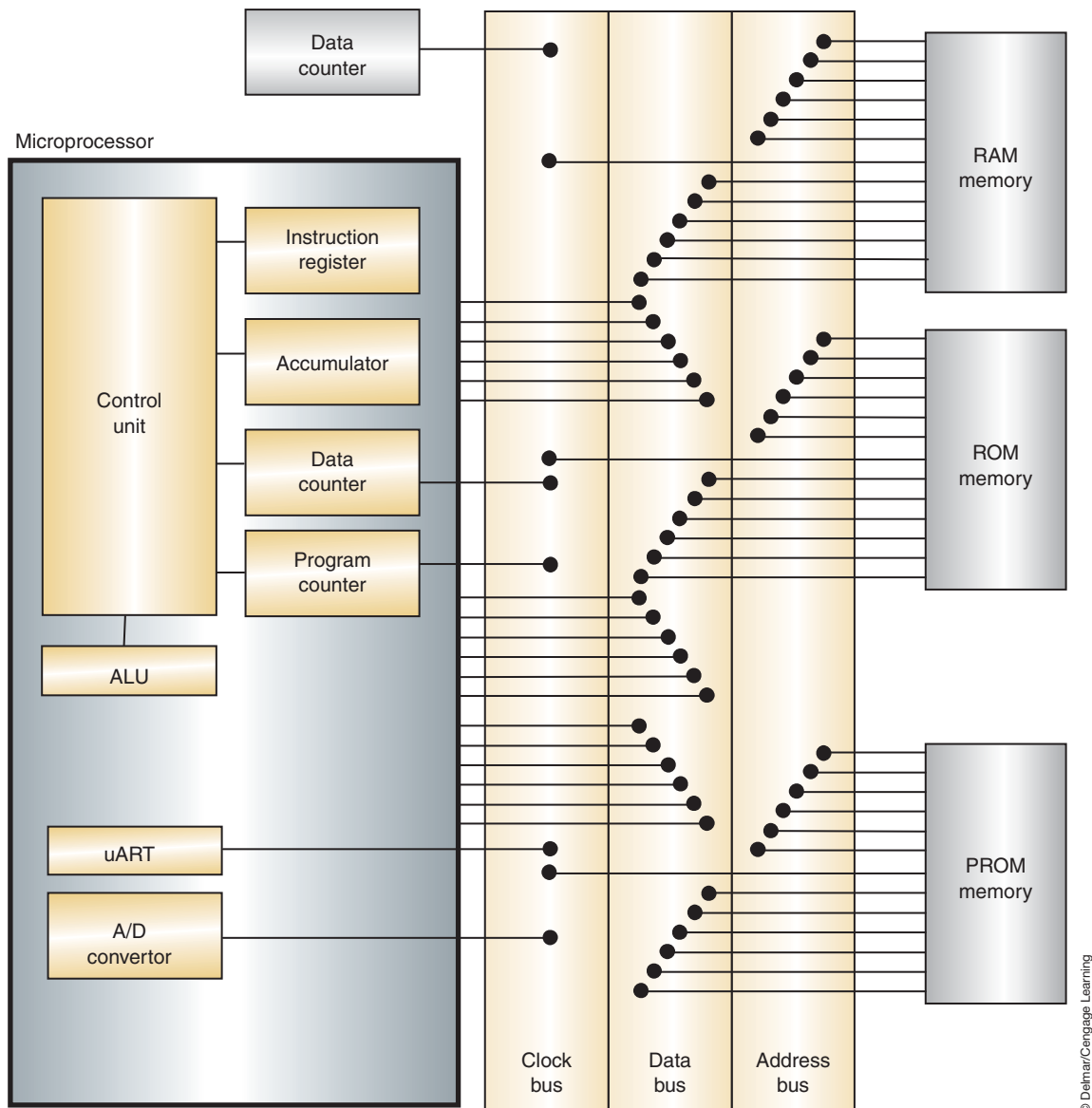


FIGURE 9-8 Main components of the computer and the  $\mu$ P.

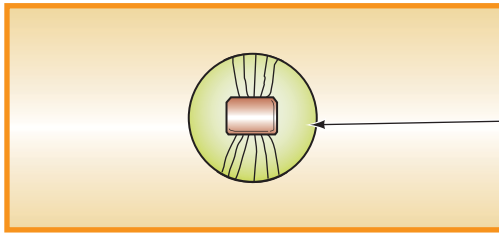
requires to make a number of decisions. In these cases, the microprocessor writes information into memory by specifying a memory address and sending information to this address.

When stored information is required, the  $\mu$ P specifies the stored information address and requests the information. When stored information is requested from a specific address, the memory sends a copy of this information to the  $\mu$ P. However, the original stored information is still retained in the memory address.

The memories store information regarding the ideal air-fuel ratios for various operating conditions. The sensors inform the computer about the engine and vehicle operating conditions. The  $\mu$ P reads the ideal air-fuel ratio information from memory and compares this information with the sensor inputs. After this comparison, the  $\mu$ P makes the necessary decision and operates the injectors to provide the exact air-fuel ratio the engine requires.

Several types of memory chips may be used in the computer:

1. **Read only memory (ROM)** contains a fixed pattern of 1's and 0's that represent permanent stored information. This information is used to instruct the  $\mu$ P on what to do in response to input data. The  $\mu$ P reads the information contained in ROM but it cannot write to it or change it. ROM is permanent memory that is programmed in. This memory



The Erasable PROM has a window such as this that the microcircuitry can be viewed through. This is normally covered by a piece of Mylar™-type material so that the information in it will not be erased by exposing it to ultraviolet light rays.

© Delmar/Cengage Learning

**FIGURE 9-9** EPROM memory is erased when the ultra-violet ray contact the microcircuitry.

is not lost when power to the computer is lost. ROM contains formulas, calibrations, and so on.

2. **Random access memory (RAM)** is constructed from flip-flop circuits formed into the chip. The RAM will store temporary information that can be read from or written to by the  $\mu\text{P}$ . RAM stores information that is waiting to be acted upon and it stores output signals that are waiting to be sent to an output device. RAM can be designed as **volatile** or **nonvolatile**. In volatile RAM, the data will be retained as long as current flows through the memory. RAM that is connected to the battery through the ignition switch will lose its data when the switch is turned off (see number 7, nonvolatile RAM).
3. **Keep alive memory (KAM)** is a version of RAM. KAM is connected directly to the battery through circuit protection devices. For example, the  $\mu\text{P}$  can read and write information to and from the KAM and erase KAM information. However, the KAM retains information when the ignition switch is turned off. KAM will be lost when the battery is disconnected, the battery drains too low, or the circuit opens.
4. **Programmable read only memory (PROM)** contains specific data that pertains to the exact vehicle in which the computer is installed. This information may be used to inform the  $\mu\text{P}$  of the accessories that are equipped on the vehicle. The information stored in the PROM is the basis for all computer logic. The information in PROM is used to define or adjust the operating perimeters held in ROM.
5. **Erasable PROM (EPROM)** is similar to PROM except that its contents can be erased to allow new data to be installed. A piece of Mylar tape covers a window. If the tape is removed, the microcircuit is exposed to ultraviolet light that erases its memory (Figure 9-9).
6. **Electrically erasable PROM (EEPROM)** allows changing the information electrically one bit at a time. Some manufacturers use this type of memory to store information concerning mileage, vehicle identification number, and options. The flash EEPROM may be reprogrammed through the data link connector (DLC) using the manufacturer's specified diagnostic equipment.
7. **Nonvolatile RAM (NVRAM)** is a combination of RAM and EEPROM in the same chip. During normal operation, data is written to and read from the RAM portion of the chip. If the power is removed from the chip, or at programmed timed intervals, the data is transferred from RAM to the EEPROM portion of the chip. When the power is restored to the chip, the EEPROM will write the data back to the RAM.

**Shop Manual**  
Chapter 5, page 373

## Adaptive Strategy and Memory

If a computer has **adaptive strategy** capabilities, the computer can actually learn from past experience. For example, the normal voltage input range from an ambient temperature sensor may be 0.6 volt to 4.5 volts. If the sensor sends a 0.4-volt signal to the computer, the  $\mu\text{P}$  interprets this signal as an indication of component wear and stores this altered calibration in the RAM. The  $\mu\text{P}$  now refers to this new calibration during calculations and normal system performance is maintained. If a sensor output is erratic or considerably out of range, the

computer may ignore this input. When a computer has adaptive strategy, a short learning period is necessary under the following conditions:

1. After the battery has been disconnected.
2. When a computer system component has been replaced or disconnected.
3. On a new vehicle.

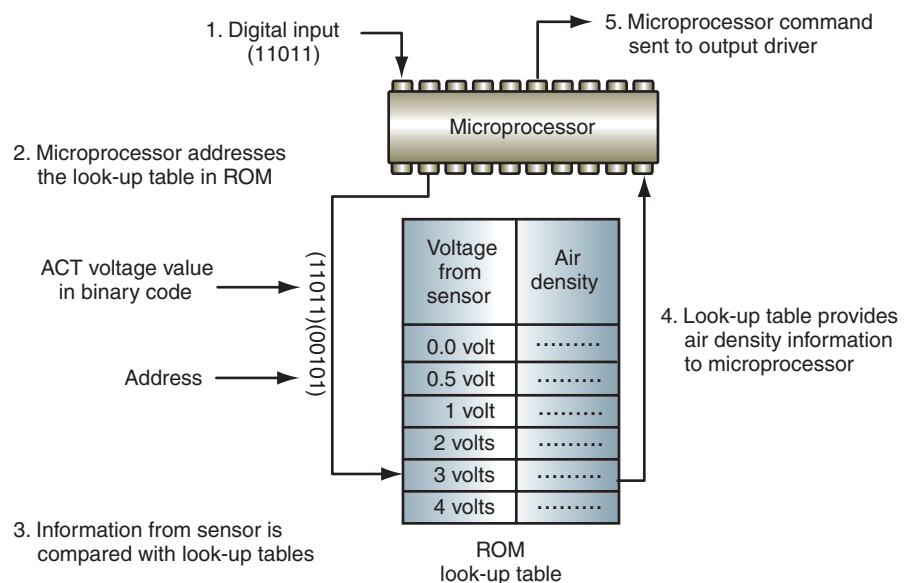
**Adaptive memory** is the ability of the computer system to store changing values in order to correct operating characteristics. For example, a transmission control module may monitor the transmission's input and output shaft speeds to determine gear ratio. If the input speed sensor indicates a speed of 1,000 rpms and the output speed sensor indicates a speed of 333 rpms then the controller determines that the ratio is 3.00 to 1 (1st gear). When the controller determines that it will make the shift to second gear (2.00 to 1 ratio) it will monitor the sensors to see how long it takes to achieve the ratio change from 3.00 to 1 to 2.00 to 1. The length of time required represents the amount of fluid needed to stroke the clutch piston and lock up the clutch element. This value is learned so the timing of the shifts can be altered as the clutch elements wear, yet the quality of the shifts will not deteriorate over the life of the transmission.

## INFORMATION PROCESSING

The air charge temperature (ACT) sensor input will be used as an example of how the computer processes information. If the air temperature is low, the air is denser and contains more oxygen per cubic foot. Warmer air is less dense and therefore contains less oxygen per cubic foot. The cold, dense air requires more fuel compared to the warmer air that is less dense. The microprocessor must supply the correct amount of fuel in relation to air temperature and density.

An ACT sensor is positioned in the intake manifold where it senses air temperature. This sensor contains a resistive element that has an increased resistance when the sensor is cold. Conversely, the ACT sensor resistance decreases as the sensor temperature increases. When the ACT sensor is cold, it sends a high-analog voltage signal to the computer, and the A/D converter changes this signal to a digital signal.

When the  $\mu\text{P}$  receives this ACT signal, it addresses the tables in the ROM. The look-up tables list air density for every air temperature. When the ACT sensor voltage signal is very high, the look-up table indicates very dense air. This dense air information is relayed to the  $\mu\text{P}$ , and the  $\mu\text{P}$  operates the output drivers and injectors to supply the exact amount of fuel the engine requires (Figure 9-10).



**FIGURE 9-10** The microprocessor addresses the lookup tables in the ROM, retrieves air density information, and issues commands to the output devices.

# Logic Gates

**Logic gates** are the thousands of field effect transistors (FETs) incorporated into the computer circuitry. These circuits are called logic gates because they act as gates to output voltage signals depending on different combinations of input signals. The FETs use the incoming voltage patterns to determine the pattern of pulses leaving the gate. The following are some of the most common logic gates and their operations. The symbols represent functions and not electronic construction:

1. **NOT gate:** A NOT gate simply reverses binary 1's to 0's and vice versa (Figure 9-11). A high input results in a low output and a low input results in a high output.
2. **AND gate:** The AND gate will have at least two inputs and one output. The operation of the AND gate is similar to two switches in series to a load (Figure 9-12). The only way the light will turn on is if switches A *and* B are closed. The output of the gate will be high only if both inputs are high. Before current can be present at the output of the gate, current must be present at the base of both transistors (Figure 9-13).
3. **OR gate:** The OR gate operates similarly to two switches that are wired in parallel to a light (Figure 9-14). If switch A *or* B is closed, the light will turn on. A high signal to either input will result in a high output.
4. **NAND and NOR gates:** A NOT gate placed behind an OR or AND gate inverts the output signal (Figure 9-15).
5. **Exclusive-OR (XOR) gate:** A combination of gates that will produce a high-output signal only if the inputs are different (Figure 9-16).

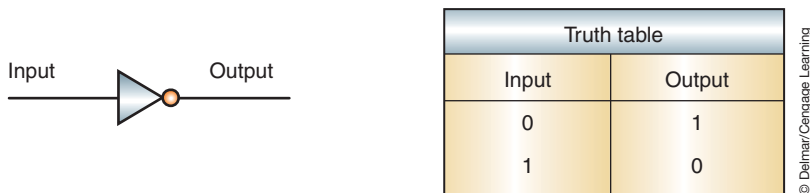


FIGURE 9-11 The NOT gate symbol and truth table. The NOT gate inverts the input signal.

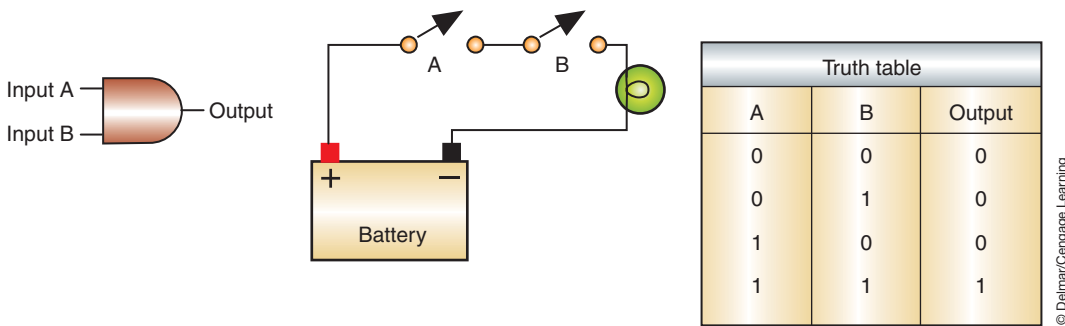


FIGURE 9-12 The AND gate symbol and truth table. The AND gate operates similar to switches in series.

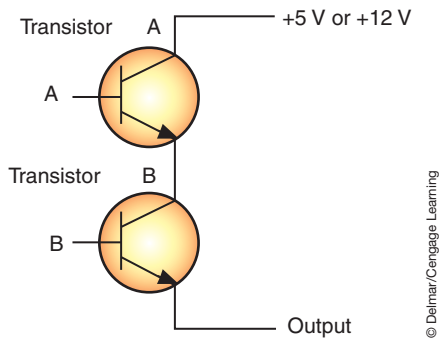


FIGURE 9-13 The AND gate circuit.

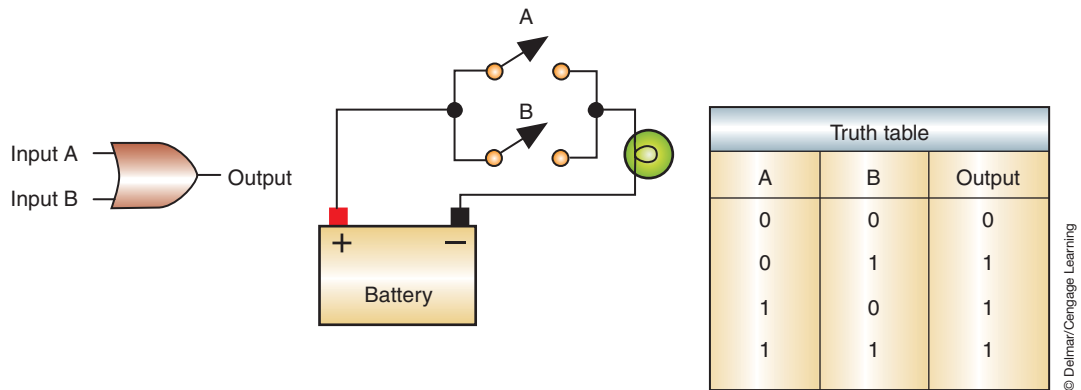


FIGURE 9-14 OR gate symbol and truth table. The OR gate is similar to parallel switches.

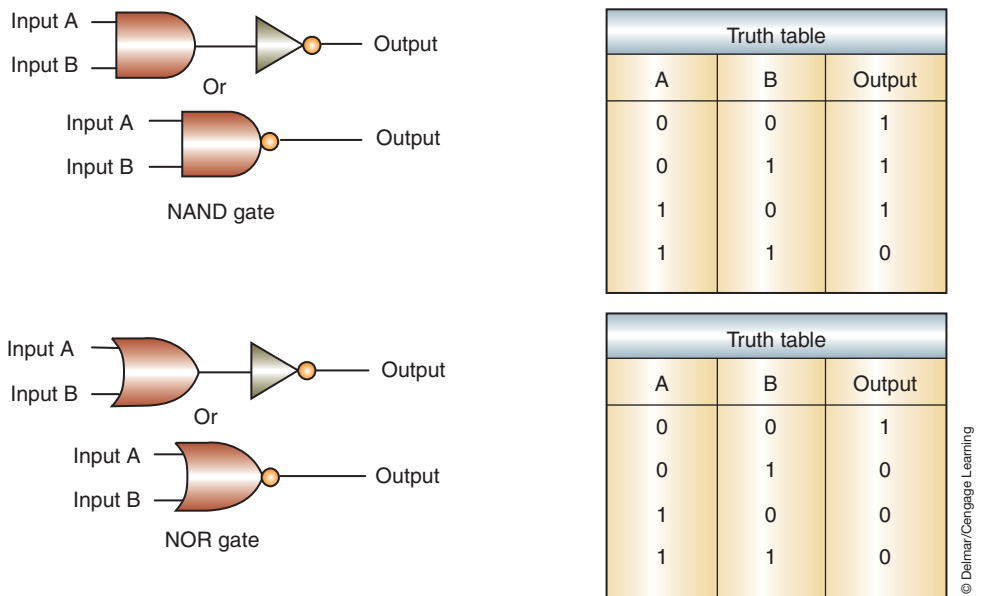


FIGURE 9-15 Symbols and truth tables for NAND and NOR gates. The small circle represents an inverted output on any logic gate symbol.

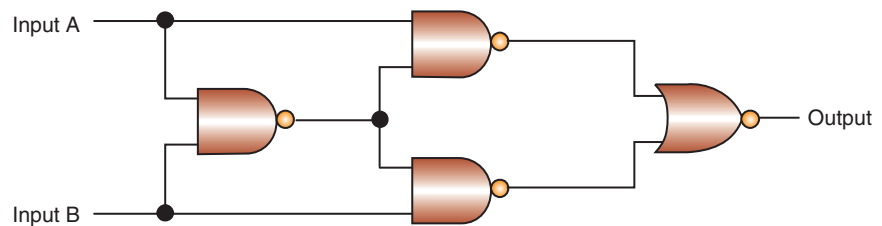
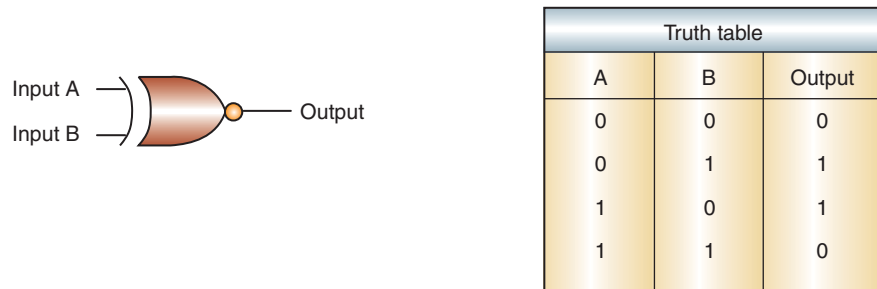
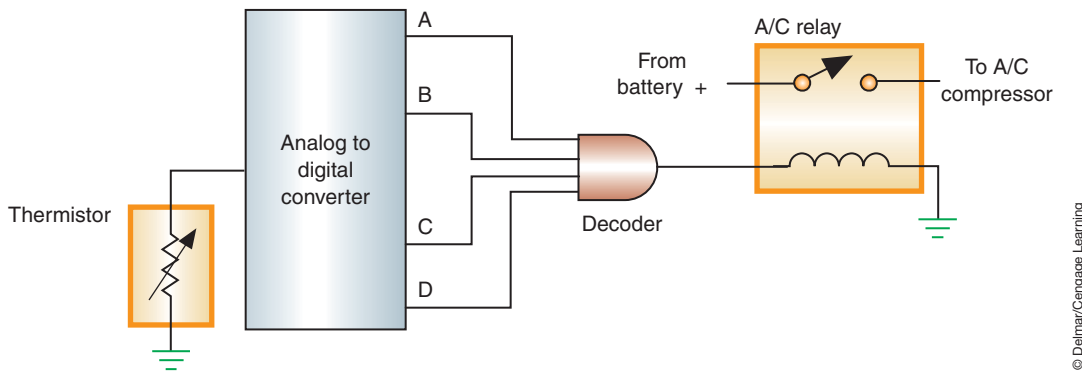


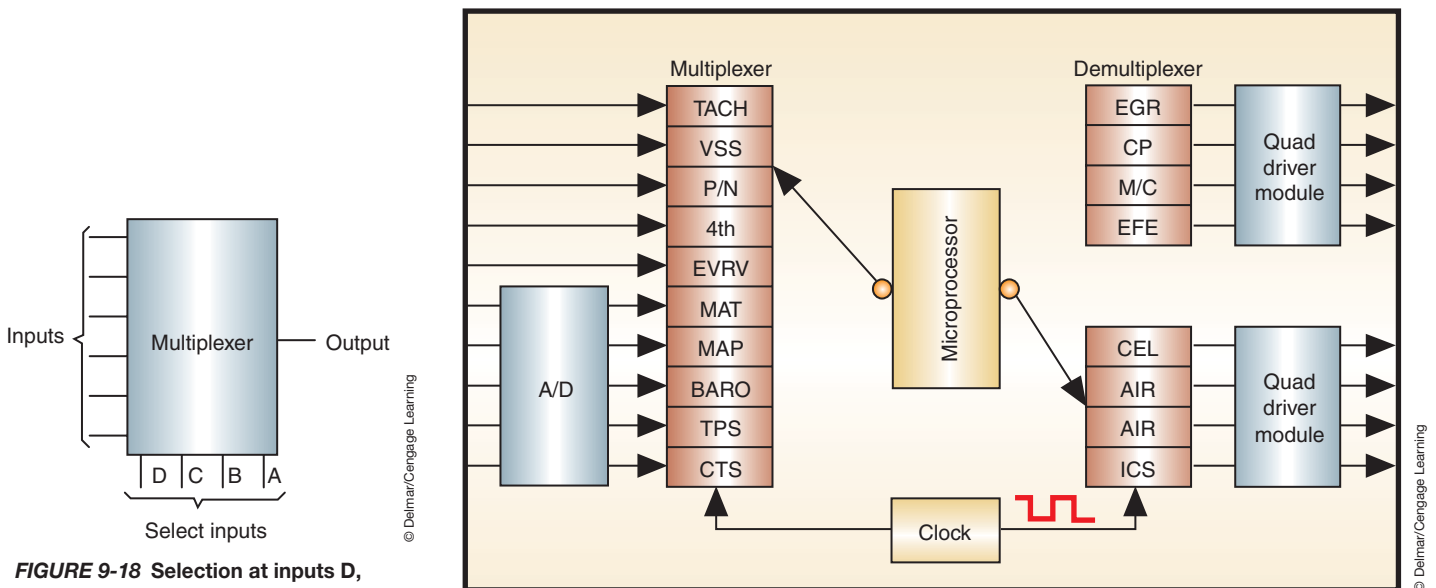
FIGURE 9-16 XOR gate symbol and truth table. A XOR gate is a combination of NAND and NOR gates.

These different gates are combined to perform the processing function. The following are some of the most common combinations:

1. **Decoder circuit:** A combination of AND gates used to provide a certain output based on a given combination of inputs (Figure 9-17). When the correct bit pattern is received by the decoder, it will produce the high-voltage signal to activate the relay coil.
2. **Multiplexer (MUX):** The basic computer is not capable of looking at all of the inputs at the same time. A multiplexer is used to examine one of many inputs depending on a programmed priority rating (Figure 9-18). This process is called **sequential sampling**. This means the computer will deal with all of the sensors and actuators one at a time.
3. **Demultiplexer (DEMUX):** Operates similar to the MUX except that it controls the order of the outputs (Figure 9-19).
4. **RS and clocked RS flip-flop circuits:** Logic circuits that remember previous inputs and do not change their outputs until they receive new input signals. The illustration (Figure 9-20) shows a basic RS flip-flop circuit. The clocked flip-flop circuit has an inverted clock signal as an input so that circuit operations occur in the proper order (Figure 9-21). Flip-flop circuits are called **sequential logic circuits** because the output is determined by the sequence of inputs. A given input affects the output produced by the next input.



**FIGURE 9-17** Simplified temperature sensing circuit that will turn on the air conditioning compressor when inside temperatures reach a predetermined value.



**FIGURE 9-18** Selection at inputs D, C, B, A will determine which data input will be processed.

**FIGURE 9-19** Block diagram representation of the MUX and DEMUX circuit.



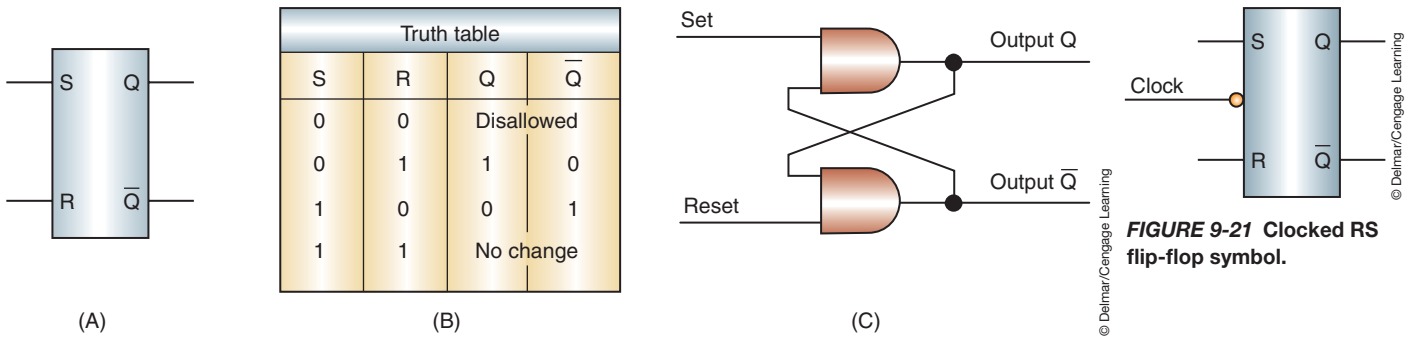


FIGURE 9-21 Clocked RS flip-flop symbol.

FIGURE 9-20 (A) RS flip-flop symbol. (B) Truth table. (C) Logic diagram. Variations of the circuit may include NOT gates at the inputs, if used, the truth table outputs would be reversed.

5. **Driver circuits:** A *driver* is a term used to describe a transistor device that controls the current in the output circuit. Drivers are controlled by the  $\mu\text{P}$  to operate high-current circuits. The high currents handled by a driver are not really that high; they are just more than what is typically handled by a transistor. Several types of driver circuits are used on automobiles, such as Quad, Discrete, Peak and Hold, and Saturated Switch driver circuits.
6. **Registers:** A register is a combination of flip-flops that transfer bits from one to another every time a clock pulse occurs (Figure 9-22). It is used in the computer to temporarily store information.
7. **Accumulators:** Registers designed to store the results of logic operations that can become inputs to other modules.

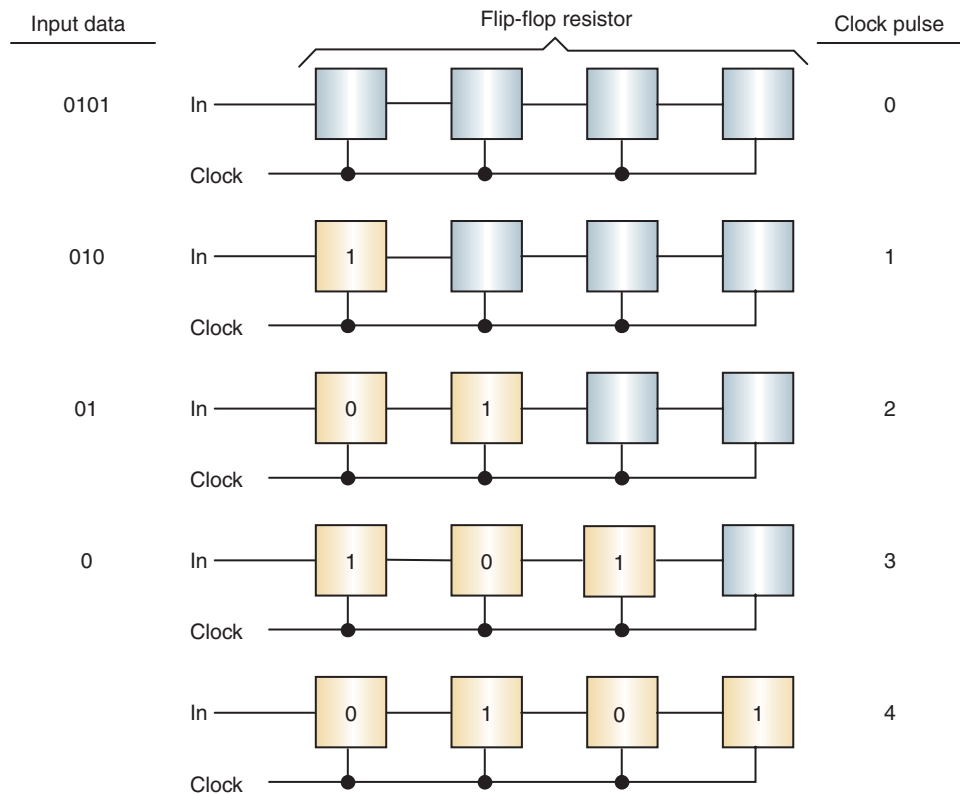


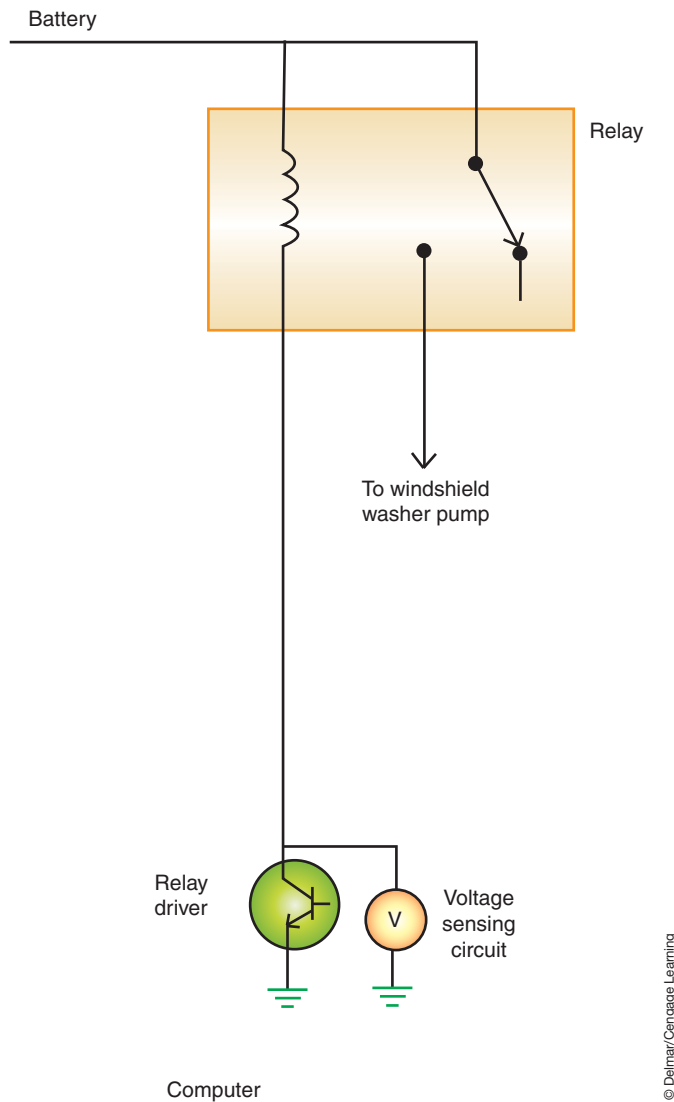
FIGURE 9-22 It takes four clock pulses to load 4 bits into the register.

## HIGH-SIDE AND LOW-SIDE DRIVERS

Usually the computer will control an actuator by the use of **low-side drivers**. These drivers will complete the path to ground through an FET transistor to control the output device. The computer may monitor the voltage on this circuit to determine if the actuator operates when commanded (Figure 9-23). Monitoring of the system can be done either by measuring voltage on the circuit or by measuring the current draw of the circuit.

Many newer vehicles are now using **high-side drivers**, which control the output device by varying the positive (12-volt) side. High-side drivers consist of a Metal Oxide Field Effect Transistor (MOSFET) that is controlled by a bipolar transistor. The bipolar transistor is controlled by the microprocessor. The advantage of the high-side driver is that it can provide quick-response self-diagnostics for shorts, opens, and thermal conditions. It also reduces vehicle wiring.

High-side driver diagnostic capabilities include the ability to determine a short circuit or open circuit condition. The high-side driver will take the place of a fuse in the event of a short



**FIGURE 9-23** Computers using low-side drivers may be able to monitor the circuit for proper operation. When the relay coil is not energized, the sense circuit should see a high (12 V) volt. When the relay is turned on, the voltage should go low (0 V).

© Delmar/Cengage Learning

circuit condition. When it senses a high-current condition, it will turn off the power flow and then store a DTC in memory. The driver will automatically reset once the short circuit condition is removed. In addition, the high-side driver monitors its temperature. The driver reports the junction temperature to the microprocessor. If a slow acting resistive short occurs in the circuit, the temperature will begin to climb. Once the temperature reaches 300°F (150°C) the driver will turn off and set a DTC.

The high-side driver is also capable of detecting an open circuit, even if the system is turned off. This is done by reading a feedback voltage to the microprocessor when the driver is off. A 5-volt, 50  $\mu$ A current is fed through the circuit, which also has a resistor wired in parallel. Low voltage (less than 2.25 volts) will indicate a normal circuit. If the voltage is high (above 2.25 volts), a high resistance or open circuit is detected. If the open circuit is detected, a DTC is set.

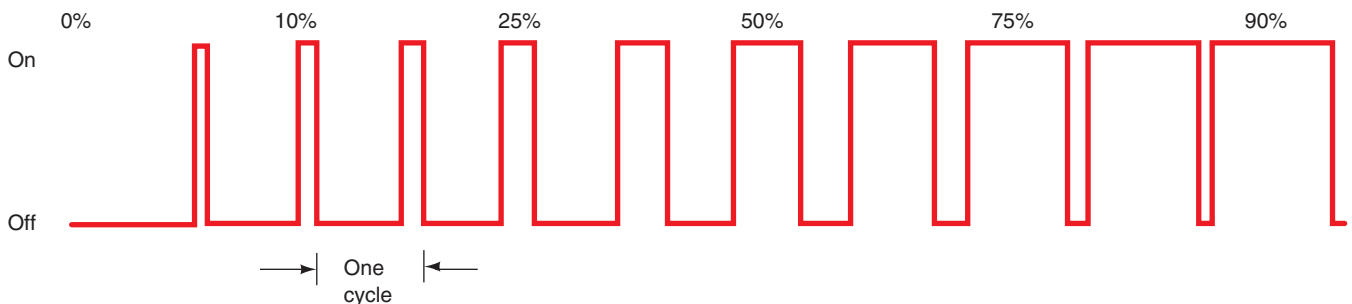
## OUTPUTS

Once the computer's programming instructs that a correction or adjustment must be made in the controlled system, an **output signal** is sent to an actuator. This involves translating the electronic signals into mechanical motion.

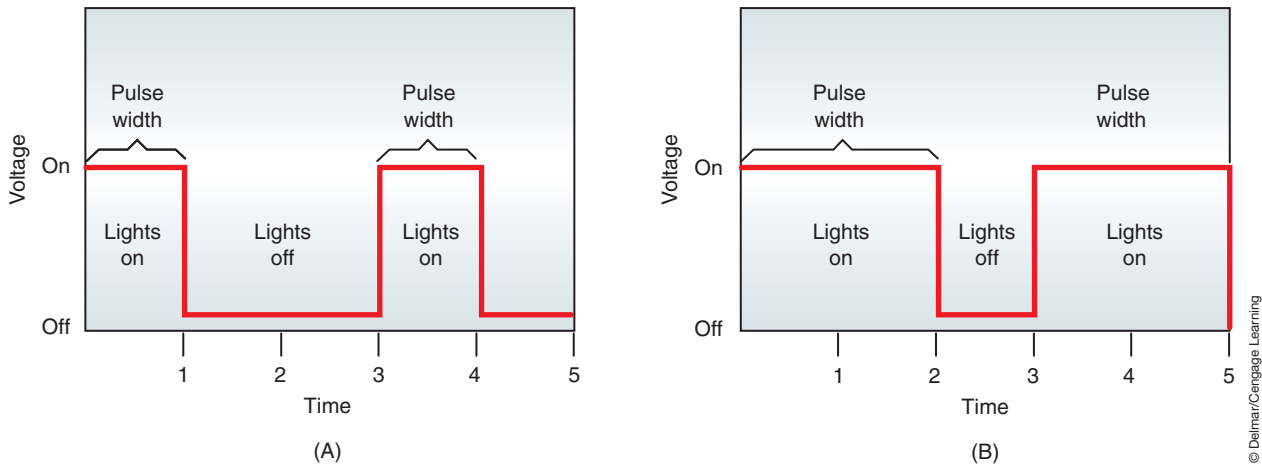
An **output driver** is used within the computer to control the actuators. The circuit driver usually applies the ground circuit of the actuator. The ground can be applied steadily if the actuator must be activated for a selected amount of time. For example, if the BCM inputs indicate that the automatic door locks are to be activated, the actuator is energized steadily until the locks are latched. Then the ground is removed.

Other systems require the actuator to be turned either on and off very rapidly or for a set amount of cycles per second. It is duty cycled if it is turned on and off a set amount of cycles per second. Most duty cycled actuators cycle ten times per second. To complete a cycle it must go from off to on to off again. If the cycle rate is ten times per second, one actuator cycle is completed in one tenth of a second. If the actuator is turned on for 30% of each tenth of a second and off for 70%, it is referred to as a 30% duty cycle (Figure 9-24).

If the actuator is cycled on and off very rapidly, the pulse width can be varied to provide the programmed results. For example, the computer program will select an illumination level of the digital instrument panel based on the intensity of the ambient light in the vehicle. The illumination level is achieved through pulse width modulation of the lights. If the lights need to be bright, the pulse width is increased, which increases the length of on-time. As the light intensity needs to be reduced, the pulse width is decreased (Figure 9-25).



**FIGURE 9-24** Duty cycle is the percentage of on time per cycle. Duty cycle can be changed; however total cycle times remains constant.



**FIGURE 9-25** Pulse width is the duration of on time. (A) Pulse width modulation to achieve dimmer dash lights. (B) Pulse width modulation to achieve brighter dash illumination.

© Delmar/Cengage Learning

## Actuators

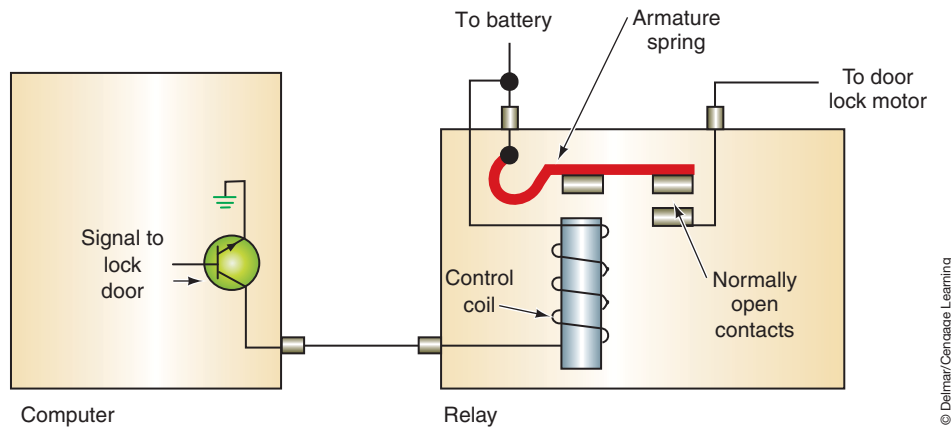
Most computer-controlled **actuators** are electromechanical devices that convert the output commands from the computer into mechanical action. These actuators are used to open and close switches, control vacuum flow to other components, and operate doors or valves, depending on the requirements of the system.

Although they do not fall into the strict definition of an actuator, the BCM can also control lights, gauges, and driver circuits.

**Relays.** A relay allows control of a high-current draw circuit by a very low current draw circuit. The computer usually controls the relay by providing the ground for the relay coil (Figure 9-26). The use of relays protects the computer by keeping the high current from passing through it. For example, the motors used for power door locks require a high current draw to operate them. Instead of having the computer operate the motor directly, it will energize the relay. With the relay energized, a direct circuit from the battery to the motor is completed (Figure 9-27).

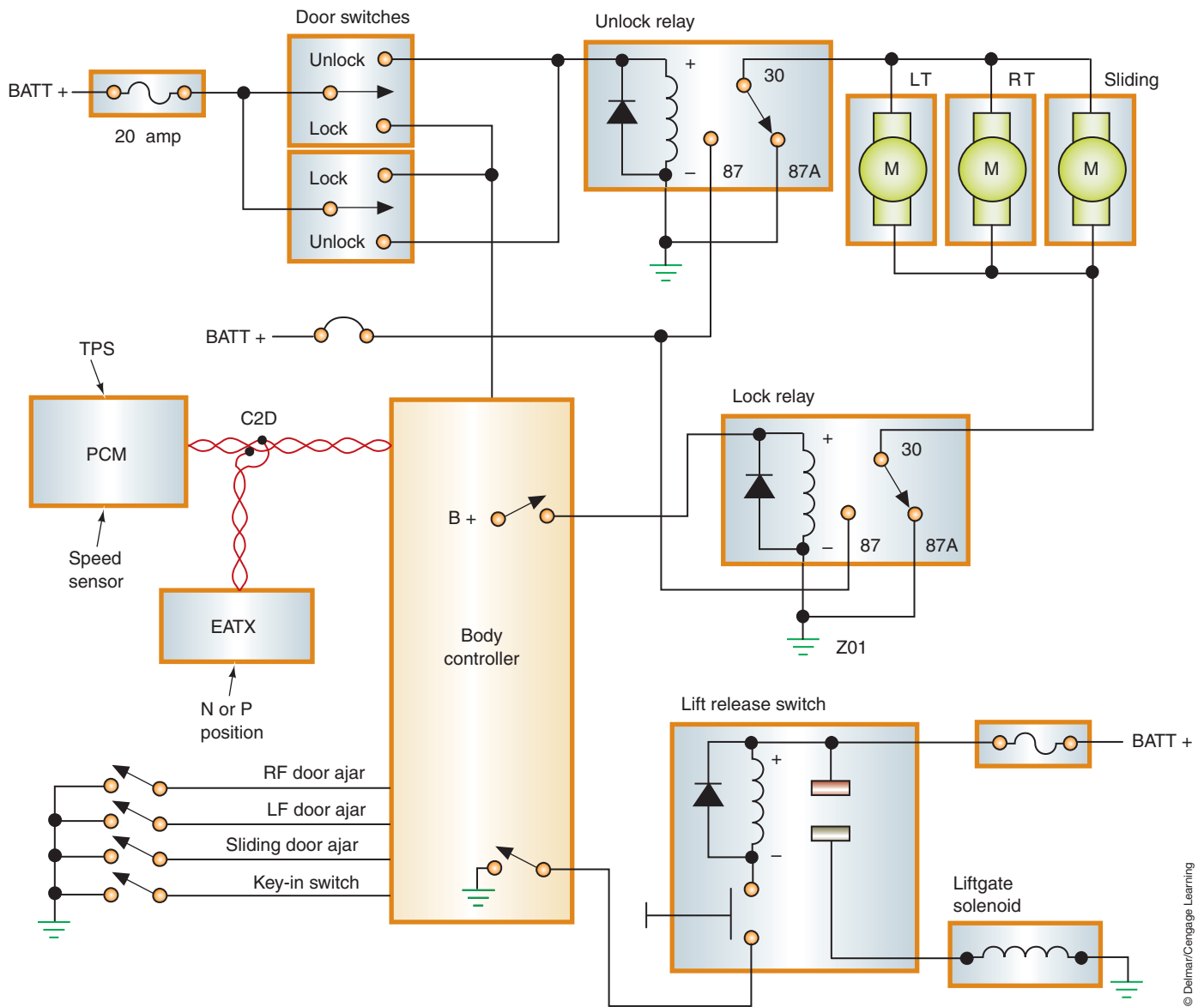
**Solenoids.** Computer control of the solenoid is usually provided by applying the ground through the output driver. A solenoid is commonly used as an actuator because it operates well under duty-cycling conditions.

**Shop Manual**  
Chapter 9, page 368



© Delmar/Cengage Learning

**FIGURE 9-26** The computer's output driver applies the ground for the relay coil.



**FIGURE 9-27** The computer controls the operation of the door lock motors by controlling the relays.

One of the most common uses of the solenoid is to control vacuum to other components. Many automatic climate control systems use vacuum motors to move the blend doors. The computer can control the operation of the doors by controlling the solenoid.

**Motors.** Many computer-controlled systems use a **stepper motor** to move the controlled device to whatever location is desired. A stepper motor contains a permanent magnet armature with two, four, or more field coils (Figure 9-28). By applying voltage pulses to selected coils of the motor, the armature will turn a specific number of degrees. When the same voltage pulses are applied to the opposite coils, the armature will rotate the same number of degrees in the opposite direction.

Some applications require the use of a permanent magnet field **servomotor** (Figure 9-29). A servomotor produces rotation of less than a full turn. A feedback mechanism is used to position itself to the exact degree of rotation required. The polarity of the voltage applied to the armature windings determines the direction the motor rotates. The computer can apply a continuous voltage to the armature until the desired result is obtained.

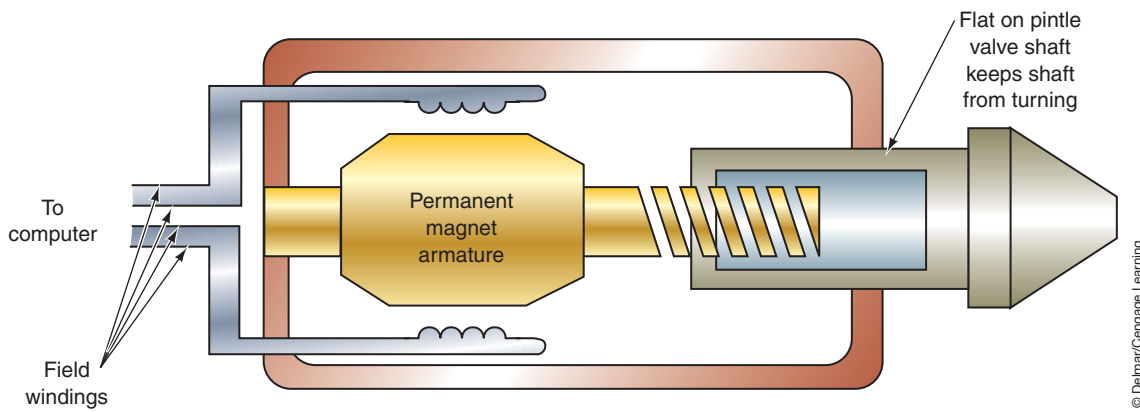


FIGURE 9-28 Typical stepper motor.

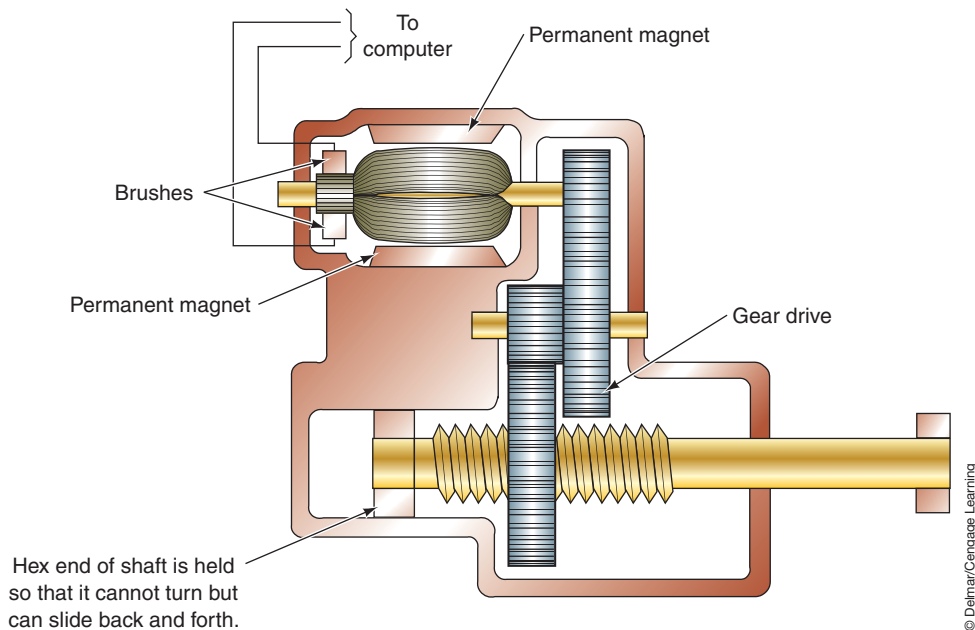


FIGURE 9-29 Reversible permanent magnet motor.

## SUMMARY

- A computer is an electronic device that stores and processes data and is capable of operating other devices.
- The operation of the computer is divided into four basic functions: input, processing, storage, and output.
- Binary numbers are represented by the numbers 1 and 0. A transistor that operates as a relay is the basis of the digital computer. As the input signal switches from off to on, the transistor output switches from cutoff to saturation. The on and off output signals represent the binary digits 1 and 0.
- Logic gates are the thousands of field effect transistors that are incorporated into the computer circuitry. The FETs use the incoming voltage patterns to determine the pattern of pulses that leave the gate. The most common logic gates are NOT, AND, OR, NAND, NOR, and XOR gates.

## TERMS TO KNOW

Adaptive memory  
 Adaptive strategy  
 Binary code  
 Bit  
 Clock circuit  
 High-side drivers  
 Interface



## SUMMARY

### TERMS TO KNOW

(continued)

Logic gates

Low-side drivers

Microprocessor

Nonvolatile

Output Driver

Output Signal

Program

Sequential logic

circuits

Sequential sampling

Servomotor

Stepper motor

Volatile

- There are several types of memory chips used in the body computer; ROM, RAM, and PROM are the most common types.
- ROM (read only memory) contains a fixed pattern of 1's and 0's representing permanent stored information used to instruct the computer on what to do in response to input data.
- RAM (random access memory) will store temporary information that can be read from or written to by the  $\mu$ P.
- PROM (programmable read only memory) contains specific data that pertains to the exact vehicle in which the computer is installed.
- EPROM (Erasable PROM) is similar to PROM except its contents can be erased to allow new data to be installed.
- EEPROM (Electrically Erasable PROM) allows changing the information electrically one bit at a time.
- NVRAM (Nonvolatile RAM) is a combination of RAM and EEPROM into the same chip.
- Actuators are devices that perform the actual work commanded by the computer. They can be in the form of a motor, relay, switch, or solenoid.
- A servomotor produces rotation of less than a full turn. A feedback mechanism is used to position itself to the exact degree of rotation required.
- A stepper motor contains a permanent magnet armature with two, four, or more field coils. It is used to move the controlled device to whatever location is desired by applying voltage pulses to selected coils of the motor.

## REVIEW QUESTIONS

### Short-Answer Essays

1. What is binary code?
  2. Describe the basics of NOT, AND, and OR logic gate operation.
  3. List and describe the four basic functions of the microprocessor.
  4. What is the difference between ROM, RAM, and PROM?
  5. Explain the differences between analog and digital signals.
  6. What is adaptive strategy?
  7. Describe the basic function of a stepper motor.
  8. Explain the function of a high-side driver.
  9. What is the difference between duty cycle and pulse width?
  10. What are the purposes of the interface?
2. The \_\_\_\_\_ is a crystal that electrically vibrates when subjected to current at certain voltage levels.
  3. \_\_\_\_\_ are registers designed to store the results of logic operations.
  4. The \_\_\_\_\_ is the brain of the computer.
  5. \_\_\_\_\_ contains specific data that pertains to the exact vehicle in which the computer is installed.
  6. The \_\_\_\_\_ gate reverses binary code.
  7. \_\_\_\_\_ drivers complete the actuator control circuit to ground.
  8. If a control circuit to an actuator is turned on and off a set amount of cycles per second it is called \_\_\_\_\_.
  9. The \_\_\_\_\_ function of the computer holds the program instructions.
  10. The input \_\_\_\_\_ converts analog signals to digital signals.

### Fill in the Blanks

1. In binary code, the number 4 is represented by \_\_\_\_\_.

## MULTIPLE CHOICE

- Technician A* says during the processing function the computer uses input information and compares it to programmed instructions.  
*Technician B* says during the output function the computer will put out control commands to various output devices.  
Who is correct?

A. A only                      C. Both A and B  
B. B only                      D. Neither A nor B
- Which of the following is correct?

A. Analog signals are either high-low, on-off, or yes-no.  
B. Digital signals are infinitely variable within a defined range.  
C. All of the above.  
D. None of the above.
- Logic gates are being discussed.  
*Technician A* says NOT gate operation is similar to that of two switches in series to a load.  
*Technician B* says an AND gate simply reverses binary 1's to 0's and vice versa.  
Who is correct?

A. A only                      C. Both A and B  
B. B only                      D. Neither A nor B
- All of the following statements about computer memory are true, EXCEPT:

A. RAM stores temporary information that can be written to and read by the CPU.  
B. ROM can only be read by the CPU.  
C. All PROM memory is flashable.  
D. Volatile memory is erased when voltage is removed.
- Nonvolatile memory is retained if removed from its power source.

A. True  
B. False
- Technician A* says EPROM memory is erased if the tape is removed and the microcircuit is exposed to ultraviolet light.  
*Technician B* says electrostatic discharge will destroy the memory chip.  
Who is correct?

A. A only                      C. Both A and B  
B. B only                      D. Neither A nor B
- Technician A* says high-side drivers control the ground side of the circuit.  
*Technician B* says high-side drivers may be capable of determining circuit faults.  
Who is correct?

A. A only  
B. B only  
C. Both A and B  
D. Neither A nor B
- Which of the following would represent the number "255" in binary code?

A. 00000000  
B. 11111111  
C. 00001111  
D. 11110000
- Which of the following is responsible for sequential sampling?

A. DEMUX  
B. Driver  
C. MUX  
D. Register
- Technician A* says the microprocessor commands actuators by output drivers.  
*Technician B* says that outputs are never controlled by supplying voltage to the actuator.  
Who is correct?

A. A only                      C. Both A and B  
B. B only                      D. Neither A nor B

# Chapter 10

## COMPUTER INPUTS

### UPON COMPLETION AND REVIEW OF THIS CHAPTER YOU SHOULD BE ABLE TO UNDERSTAND AND DESCRIBE:

- The function of input devices.
- The purpose of the thermistor and how it is used in a circuit.
- The difference between NTC and PTC thermistors.
- The operation and purpose of the Wheatstone Bridge.
- The operation and purpose of piezoelectric devices.
- The operation and purpose of piezoresistive devices.
- The function of the potentiometer and how it is used.
- The purpose and operation of magnetic pulse generators.
- The purpose and operation of Hall-effect switches.
- The function of the pull-down sense circuit.
- The function of the pull-up sense circuit.
- The purpose and operation of feedback systems.

### INTRODUCTION

As discussed in Chapter 9, the microprocessor receives inputs that it checks with programmed values. Several types of input devices are used to gather information for the computer to use in determining the desired output. Many input devices are also used as a feedback signal to confirm proper positioning of the actuator. Depending on the input, the computer will control the actuator(s) until the programmed results are obtained (Figure 10-1). The inputs can come from other computers, the vehicle operator, the technician, or through a variety of sensors.

Driver input signals are usually provided by momentarily applying a ground through a switch. The computer receives this signal and performs the desired function. For example, if the driver wishes to reset the trip odometer on a digital instrument panel, he would push the reset switch. This switch will provide a momentary ground that the computer receives as an input and sets the trip odometer to zero.

Switches can be used as an input for any operation that only requires a yes–no, or on–off, condition. Other inputs include those supplied by means of a sensor and those signals returned to the computer in the form of feedback.

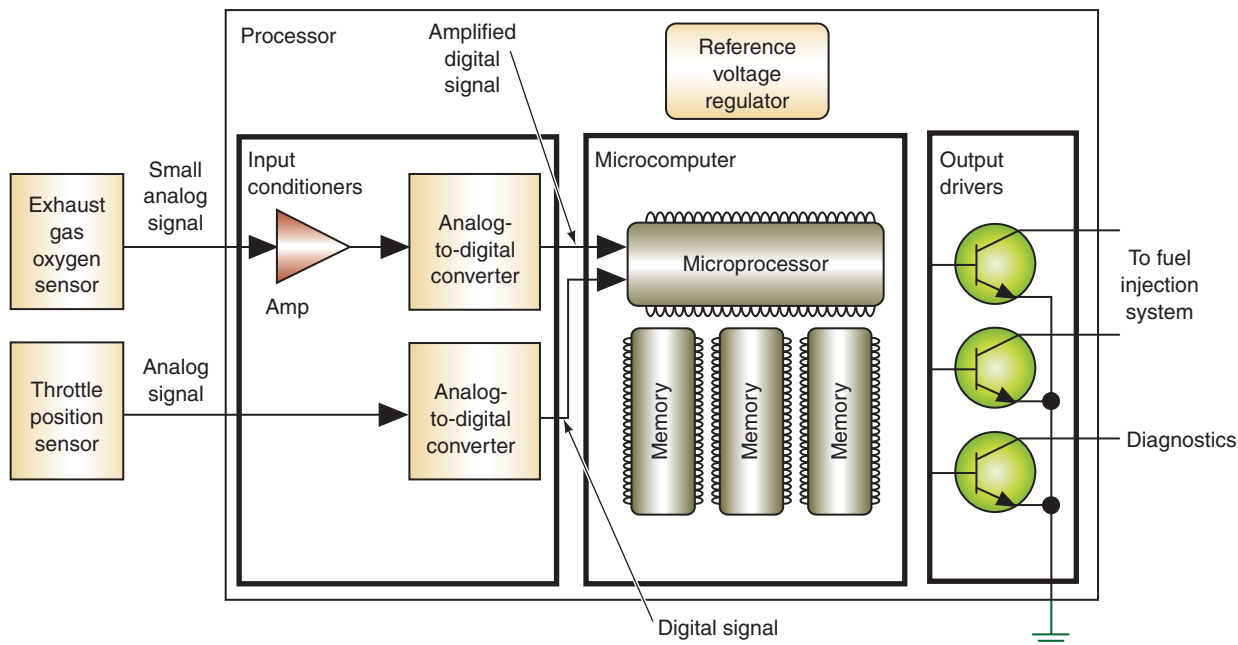
This chapter discussed the many different designs of **sensors** and inputs. Sensors convert some measurement of vehicle operation into an electrical signal. Some sensors are nothing more than a switch that completes the circuit. Others are complex chemical reaction devices that generate their own voltage under different conditions. Repeatability, accuracy, operating range, and **linearity** are all requirements of a sensor.

Sensors discussed in this chapter include common forms of electrical and electronic devices. These include the following:

#### Shop Manual

Chapter 10, page 391

**Linearity** refers to the sensor signal being as constantly proportional to the measured value as possible. It is an expression of the sensor's accuracy.



© Delmar/Cengage Learning

**FIGURE 10-1** The input signals are processed in the microprocessor. The microprocessor directs the output drivers to activate actuators as instructed by the program.

- **Thermistor**—a solid-state variable resistor made from a semiconductor material that changes resistance in relation to temperature changes.
- **Wheatstone Bridge**—A series-parallel arrangement of resistors between an input terminal and ground. The sensing circuit will receive a voltage reading that is proportional to the amount of resistance change.
- **Piezoelectric device**—A voltage generator with a resistor connected in series that is used to measure fluid and air pressures.
- **Piezoresistive device**—Similar to a piezoelectric except they operate like a variable resistor. Its resistance value changes as the pressure applied to the crystal changes.
- **Potentiometer**—A voltage divider that provides a variable DC voltage reading to the computer. The potentiometer usually consists of a wire wound resistor with a moveable center wiper.
- **Magnetic pulse generators**—Commonly used to send data to the computer about the speed of the monitored component. They use the principle of magnetic induction to produce a voltage signal.
- **Hall-effect switch**—A switch that operates on the principle that if a current is allowed to flow through thin conducting material that is exposed to a magnetic field, another voltage is produced. The switch contains a permanent magnet, a thin semiconductor layer made of gallium arsenate crystal (Hall layer), and a shutter wheel.

## THERMISTORS

Thermistors are commonly used to measure the temperature of liquids and ambient air. A thermistor is a solid-state variable resistor made from a semiconductor material, such as metal oxides, that have very reproducible resistance versus temperature properties.

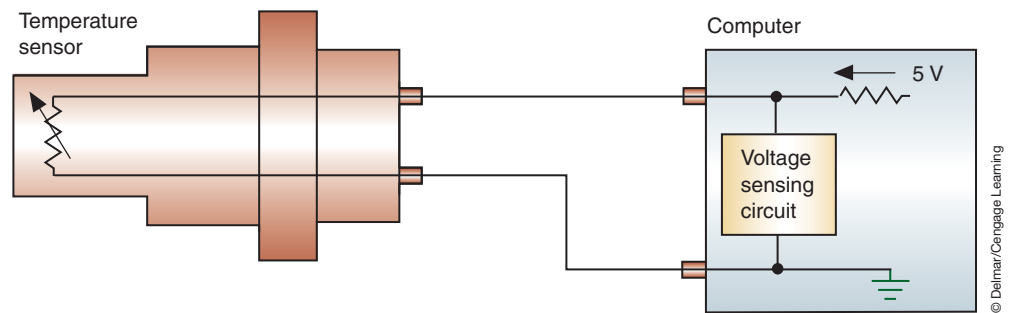
By monitoring the thermistor's resistance value, the computer is capable of observing very small changes in temperature. The computer sends a reference voltage to the thermistor (usually 5 volts) through a fixed resistor. As the current flows through the thermistor resistance to ground, a voltage sensing circuit measures the voltage after the fixed resistor (Figure 10-2). The voltage dropped over the fixed resistor will change as the resistance of the thermistor changes. Using its programmed values, the computer is able to translate the voltage drop into a temperature value.

**Shop Manual**  
Chapter 10, page 394

Dual range circuits are also referred to as dual ramping circuits.

There are two types of thermistors: **negative temperature coefficient (NTC) thermistors** and **positive temperature coefficient (PTC) thermistors**. NTC thermistors reduce their resistance as the temperature increases, while PTC thermistors increase their resistance as the temperature increases. The NTC is the most commonly used.

Using the circuit shown in Figure 10-2, if the value of the fixed resistor is 10K ohms and the value of the thermistor is also 10K ohms, the voltage sensing circuit will read a voltage value of 2.5 volts. If the thermistor is a NTC, as the ambient temperature increases its resistance decreases. If the resistance of the NTC is now 8K ohms, the voltage reading by the voltage sensing circuit will now be 2.22 volts. As ambient temperature increases and the NTC value continues to decrease, the voltage sensing circuit will measure a voltage decrease (Figure 10-3). If the thermistor was a PTC, the opposite would be true and the voltage sensing circuit would measure an increase in voltage as the ambient temperature increases.

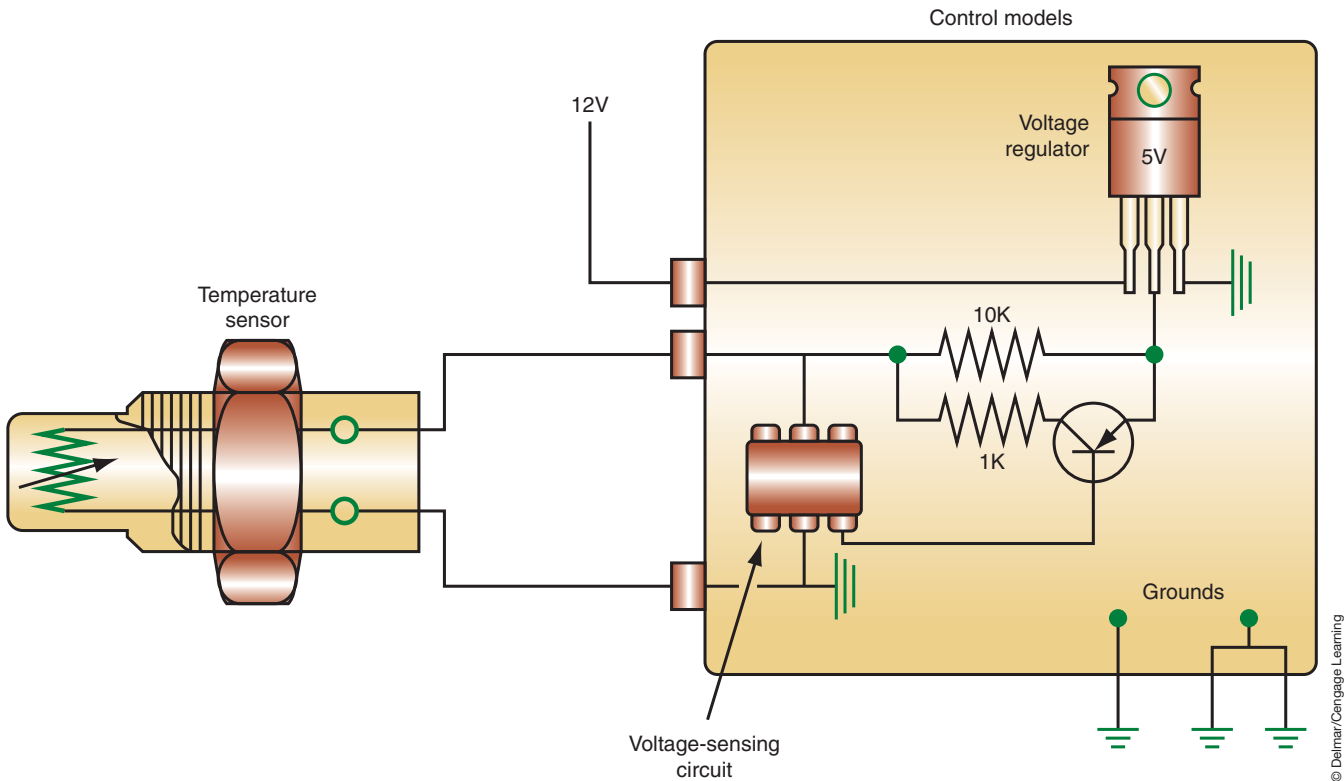


**FIGURE 10-2** A thermistor is used to measure temperature. The sensing unit measures the resistance change and translates the data into temperature values.

Temperature Sensor			
Voltages vs. Temperature Values			
Cold Temperature		Hot Temperature	
Degrees F	Volts	Degrees F	Volts
-20	4.70	110	4.20
-10	4.57	120	4.10
0	4.45	130	4.00
10	4.30	140	3.60
20	4.10	150	3.40
30	3.90	160	3.20
40	3.60	170	3.02
50	3.30	180	2.80
60	3.00	190	2.60
70	2.75	200	2.40
80	2.44	210	2.20
90	2.15	220	2.00
100	1.83	230	1.80
110	1.57	240	1.62
120	1.25	250	1.45

**FIGURE 10-3** Chart of temperature and voltage correlation.

Some temperature sensing circuits are designed as **dual range** circuits (Figure 10-4). This circuit provides for a switch in the resistance values to allow the microprocessor to more accurately measure temperatures. When the voltage sensing circuit records a calibrated voltage value (1.25 volts for example), the microprocessor will turn on the transistor which places the 1K resistor in parallel with the 10K resistor. The circuit will operate the same as described until the 1.25 volts is recorded. With the 1K resistor now involved in the circuit the resistance of the fixed resistor portion of the circuit is now 909 ohms. At this occurrence, the voltage sensing circuit will record the sharp increase of voltage and a second range of values can be used. Depending of which side of the switch the voltage is sensed, it can represent two totally different temperatures (Figure 10-5).



**FIGURE 10-4** Dual ramp temperature sensor circuit.

COLD	HOT
10K-ohm resistor	909-ohm resistor
-20°F 4.7 V	110°F 4.2 V
0°F 4.4 V	130°F 3.7 V
20°F 4.1 V	150°F 3.4 V
40°F 3.6 V	170°F 3.0 V
60°F 3.0 V	180°F 2.8 V
80°F 2.4 V	200°F 2.4 V
100°F 1.8 V	220°F 2.0 V
120°F 1.2 V	240°F 1.6 V

**FIGURE 10-5** The same voltage value can represent different temperatures.



## PRESSURE SENSORS

This section discusses the various types of pressure sensors that are used in automotive applications. In some instances, a simple pressure switch is used. In systems that require monitoring of the exact pressure electromechanical pressure sensors, piezoresistive, or piezoelectric sensor are used. These sensors convert the applied pressure to an electrical signal. A wide variety of materials and technologies has been used in these devices. These sensors are used to measure the atmospheric air pressure, manifold pressure, pressure of a gas (such as R134a), exhaust pressures, fluid pressures, and so forth. The types of sensors that can be used include; potentiometric, strain gauges using Wheatstone bridges or capacitance discharge, piezoelectric transducers, and pressure differential sensors.

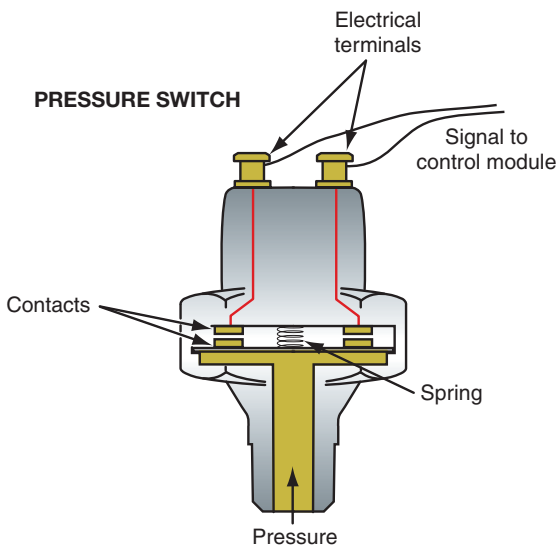
### Pressure Switches

Pressure switches will usually use a diaphragm that works against a calibrated spring or other form of tension (Figure 10-6). When pressure is applied to the diaphragm that is of a sufficient value to overcome the spring tension a switch is closed. Current that is supplied to the switch now has a completed path to ground. In a very simple warning light circuit, the closed pressure switch completed the circuit for the bulb and alerts the driver to an unacceptable condition. For example a simple oil pressure warning lamp circuit will use a pressure switch.

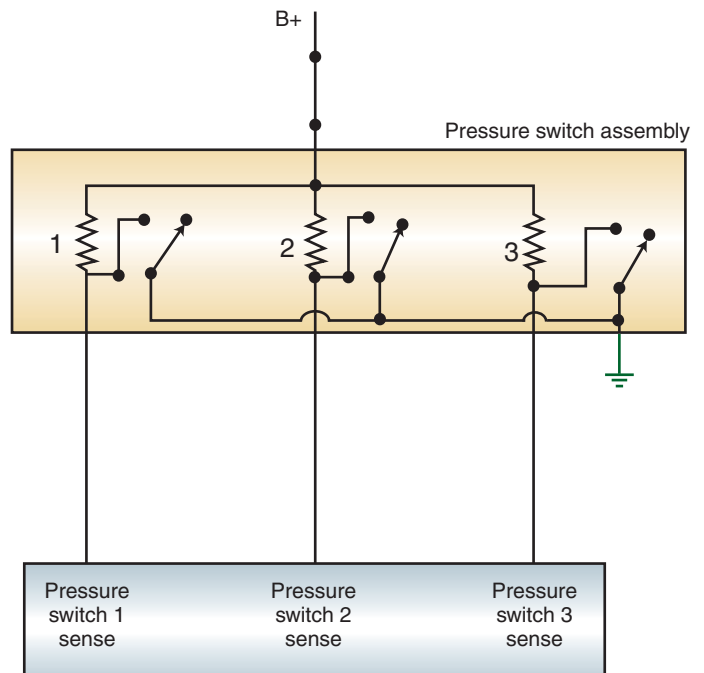
Computer monitored pressure switch circuits use the change in voltage as an indication of pressure. When the pressure change (either from low to high or high to low) changes the state of the switch, the voltage change is interpreted by the computer (Figure 10-7). Pressure switches are used to monitor the presence of pressure that is above or below a setpoint; they do not indicate the exact amount of pressure being applied.

### Potentiometric Pressure Sensor

One of the basic types of pressure sensor is the **potentiometric pressure sensor**. The potentiometric pressure sensors use a Bourdon tube, a capsule, or bellows to move a wiper arm on



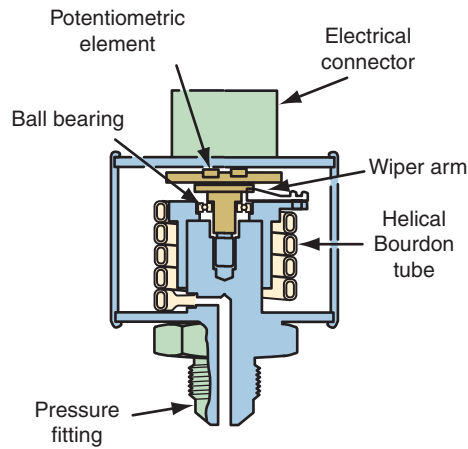
**FIGURE 10-6** Simple pressure switch uses contacts to complete electrical circuit.



**FIGURE 10-7** Computer monitors pressure switch circuit.

### Shop Manual

Chapter 10, page 397



© Delmar/Cengage Learning

**FIGURE 10-8** Potentiometric pressure sensors use a Bourdon tube, capsule, or bellows to drive a wiper arm on a resistive element.

a resistive element (Figure 10-8). Using the principle of variable resistance, the movement of the wiper across the resistive element will record a different voltage reading to the computer. Although this type of sensor can be used as a computer input, a computer is not always involved. Some early analog instrument panels used this sensor unit with an air core gauge to display engine oil pressure.

## Piezoresistive Devices

A **strain gauge** sensor determines the amount of applied pressure by measuring the strain a material experiences when subjected to the pressure. In their simplest form, a strain gauge sensor is a piezoresistive device. A piezoresistive sensor behaves like a variable resistor because its resistance value changes as the pressure applied to the sensing material changes. This type of sensor changes resistance values as a function of pressure changes.

A voltage regulator supplies a constant voltage to the sensor. Since the amount of voltage that the sensor drops will change with the change of resistance, the control module can determine the amount of pressure on the sensing material by measuring the voltage drop across the sensor. Piezoresistive sensors are commonly used as a gauge sending unit. (Figure 10-9).

## Wheatstone Bridges

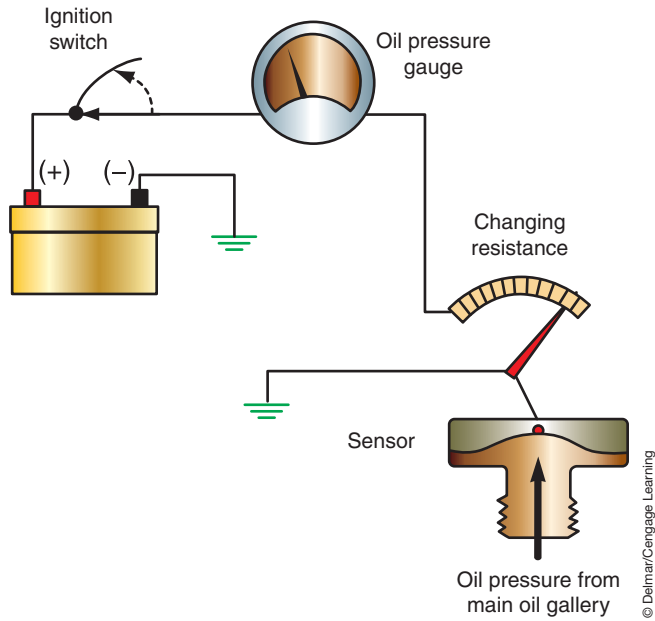
A Wheatstone bridge is commonly used to measure changes in pressure or strain. Although commonly used for engine control systems, body and chassis control systems that use them include tire pressure monitoring and supplemental restraint systems.

A Wheatstone bridge is nothing more than two simple series circuits connected in parallel across a power supply (Figure 10-10). Usually three of the resistors are kept at exactly the same value and the fourth is the sensing resistor. When all four resistors have the same value, the bridge is balanced and the voltage sensor will indicate a value of 0 volts. The output from the amplifier acts as a voltmeter. Remember, since a voltmeter measures electrical pressure between two points, it will display this value. For example, if the reference voltage is 5 volts and the resistors have the same value, then the voltage drop over each resistor is 2.5 volts. Since the voltmeter is measuring the potential on the line between  $R_3$  and  $R_1$  and  $R_2$  and  $R_3$ , it will read 0 volts because both of these lines have 2.5 volts on them. If there is a

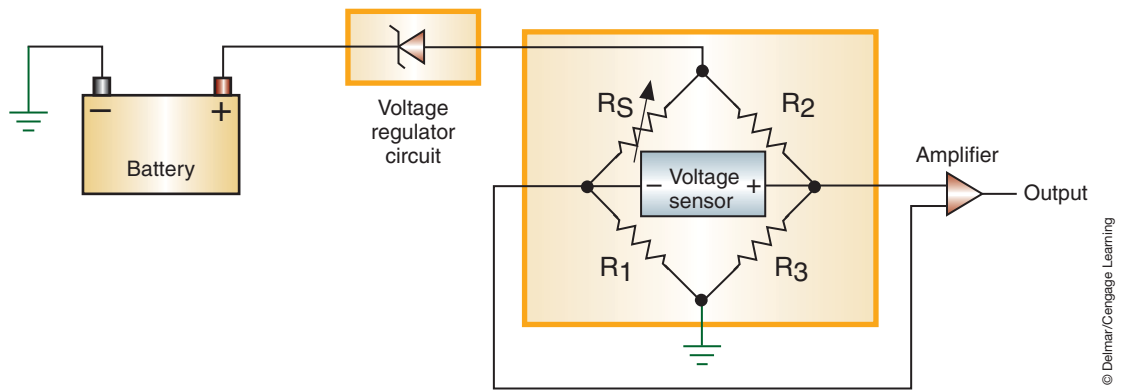
Strain gauges are also called stress gauges.

The term “piezo” refers to pressure and is derived from the Greek to mean “to be pressed.”

**Shop Manual**  
Chapter 10, page 400



**FIGURE 10-9** Oil pressure sensor used in gauge indicator circuit.

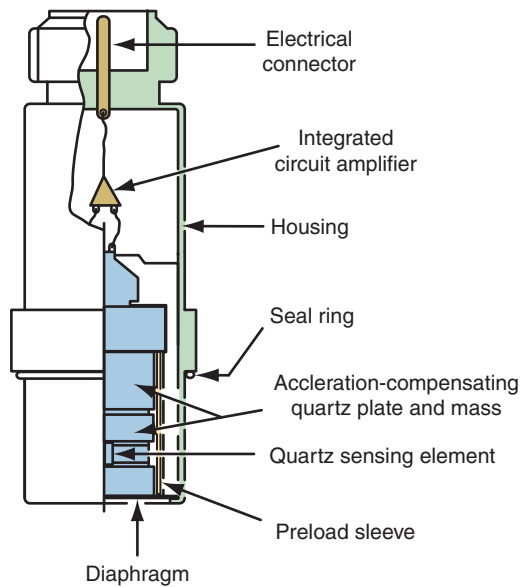


**FIGURE 10-10** Wheatstone bridge.

change in the resistance value of the sense resistor, a change will occur in the circuit's balance. The sensing circuit will receive a voltage reading that is proportional to the amount of resistance change.

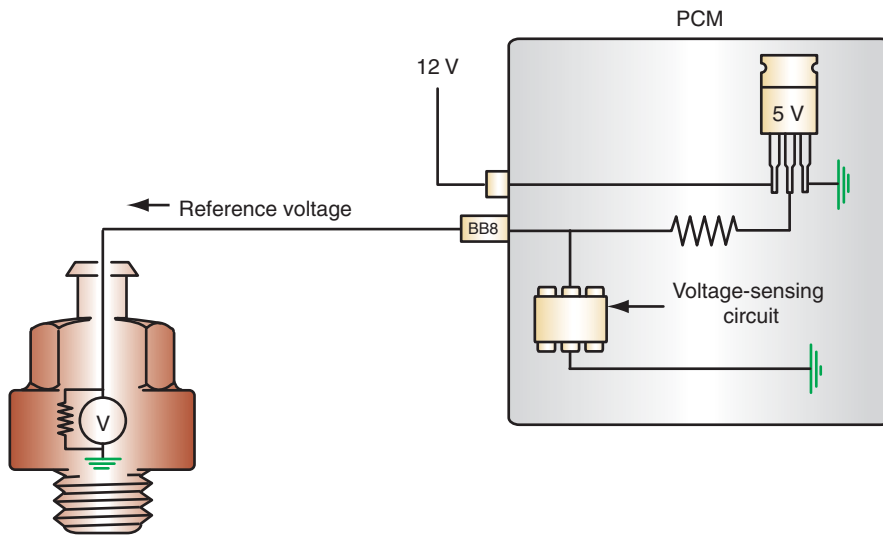
## Piezoelectric Devices

Piezoelectric devices are used to measure pressures by the generation of voltage. Piezoelectric sensors are constructed from alumina ceramics, metallized quartz, single crystals, or ultrasonic transducer materials that make up a bi-directional transducer capable of converting stress into an electric potential (Figure 10-11). The piezoelectric materials consist of polarized ions within the crystal. As pressure is applied on the piezoelectric material some mechanical deformation occurs in the polarized crystal, which produces a proportional output charge due to the displacement in the ions. Uses of this type of sensor in the automotive industry include piezoelectric accelerometers, piezoelectric force sensors, and piezoelectric pressure sensors.



© Delmar/Cengage Learning

**FIGURE 10-11** Piezoelectric sensors convert stress into an electric potential and vice versa. Sensors based on this technology are used to measure varying pressures.



© Delmar/Cengage Learning

**FIGURE 10-12** Piezoelectric sensor circuit.

The sensor is a voltage generator and has a resistor connected in series with it (Figure 10-12). The resistor protects the sensor from excessive current flow in case the circuit becomes shorted. The voltage generator is a thin ceramic disc attached to a metal diaphragm. When engine knock occurs, the vibration of the noise puts pressure on the diaphragm. This puts pressure on the piezoelectric crystals in the ceramic disc. The disc generates a voltage that is proportional to the amount of pressure. The voltage generated ranges from zero to one or more volts. Each time the engine knocks, the sensor generates a voltage spike.

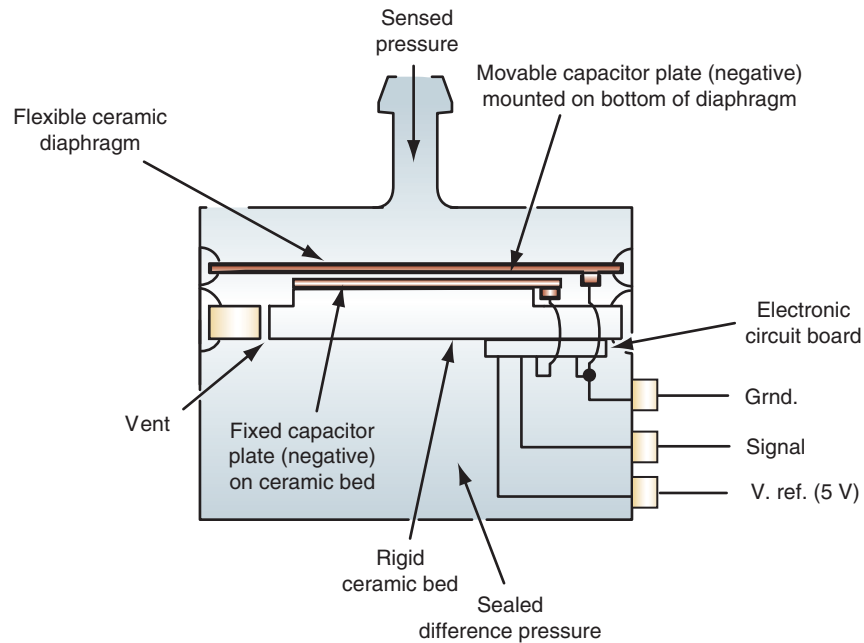


FIGURE 10-13 Capacitance discharge sensor.

**Shop Manual**

Chapter 10, page 403

## Capacitance Discharge Sensors

Another variation of the piezosensor uses capacitance discharge. Instead of using a silicon diaphragm, the **capacitance discharge sensor** uses a variable capacitor. In the capacitor capsule-type sensor, two flexible alumina plates are separated by an insulating washer (Figure 10-13). A film electrode is deposited on the inside surface of each plate and a connecting lead is extended for external connections. The result of this construction is a parallel plate capacitor with a vacuum between the plates. This capsule is placed inside a sealed housing that is connected to the sensed pressure. If constructed to measure vacuum, as the pressure increases (goes toward atmospheric), the alumina plates deflect inward, resulting in a decrease in the distance between the electrodes.

As the distance between the electrodes changes, so does the capacity of the capacitor. A measure of capacitance constitutes a measurement of pressure that is detected by a bridge circuit. The output from the bridge circuit can be either an analog DC voltage or applied to a chip that produces a frequency modulated digital signal.

## POSITION AND MOTION DETECTION SENSORS

Many electronic systems require input data concerning position, motion, and speed. Most motion and speed sensors use a magnet as the sensing element or sensed target to detect rotational or linear speed. The types of magnetic speed sensors include magnetoresistive (MR), inductive, variable reluctance (VR), and Hall-effect. In addition, the potentiometer and commutator pulse counting can be used to detect position.

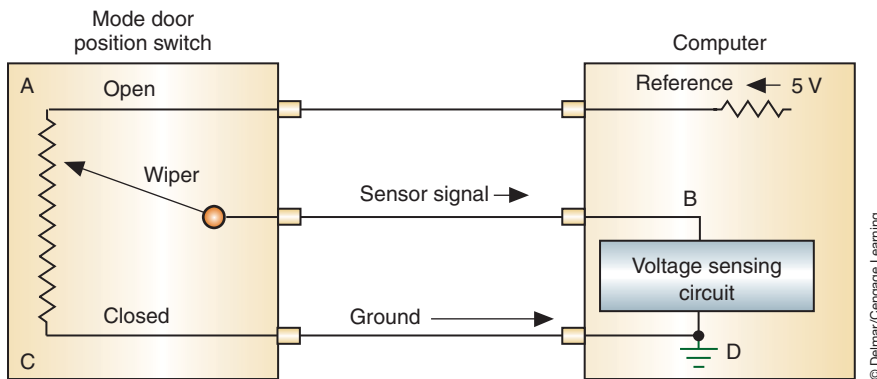
Some systems require the use of photoelectric sensors that use light sensitive elements to detect the movement of an object. In addition, solid state accelerometers, axis rotation sensors, yaw sensors, and roll sensors are becoming common components on many systems. This chapter will explore the operation of common position and motion detection sensors.

**Shop Manual**

Chapter 10, page 407

## Potentiometer

A common position sensor used to monitor linear or rotary motion is the potentiometer. A potentiometer is a voltage divider that provides a variable DC voltage reading to the



**FIGURE 10-14** A potentiometer sensor circuit measures the amount of voltage drop to determine position.

computer. These sensors are typically used to determine the position of a valve, air conditioning unit door, seat track, and so on.

The potentiometer usually consists of a wire wound resistor with a moveable center wiper (Figure 10-14). A constant voltage value (usually 5 volts) is applied to terminal A. If the wiper (which is connected to the shaft or moveable component of the unit that is being monitored) is located close to this terminal, there will be low voltage drop represented by high voltage signal back to the computer through terminal B. As the wiper is moved toward the C terminal, the sensor signal voltage to terminal B decreases. The computer interprets the different voltage value into different shaft positions. The potentiometer can measure linear or rotary movement. As the wiper is moved across the resistor, the position of the unit can be tracked by the computer.

Since applied voltage must flow through the entire resistance, temperature and other factors do not create false or inaccurate sensor signals to the computer. A rheostat is not as accurate and its use is limited in computer systems.

## Magnetic Pulse Generator

An example of the use of magnetic pulse generators is to determine vehicle and individual wheel speed. The signals from the speed sensors are used for computer-driven instrumentation, cruise control, antilock braking, speed sensitive steering, and automatic ride control systems. The magnetic pulse generator is also used to inform the computer of the position of a monitored component. This is common in engine controls where the computer needs to know the position of the crankshaft in relation to rotational degrees.

The components of the pulse generator are (Figure 10-15):

1. A **timing disc** that is attached to the rotating shaft or cable. The number of teeth on the timing disc is determined by the manufacturer and depends on application. The teeth will cause a voltage generation that is constant per revolution of the shaft. For example, a vehicle speed sensor may be designed to deliver 4,000 pulses per mile. The number of pulses per mile remains constant regardless of speed. The computer calculates how fast the vehicle is going based on the frequency of the signal.
2. A **pickup coil** consists of a permanent magnet that is wound around by fine wire.

An air gap is maintained between the timing disc and the pickup coil. As the timing disc rotates in front of the pickup coil, the generator sends an A/C signal (Figure 10-16). As a tooth on the timing disc aligns with the core of the pickup coil, it repels the magnetic field. The magnetic field is forced to flow through the coil and pickup core (refer to Figure 10-15). Since the magnetic field is not expanding, a voltage of zero is induced in the pickup coil. As the tooth passes the core, the magnetic field is able to expand

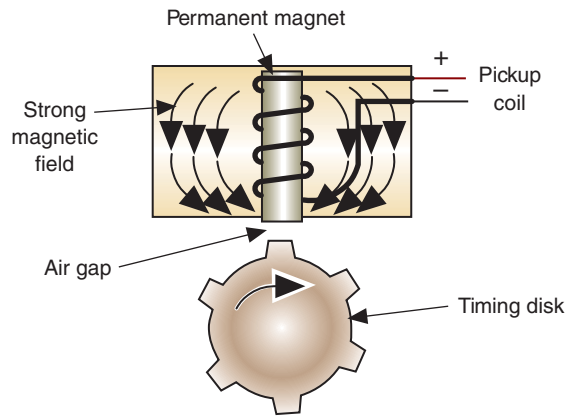
### Shop Manual

Chapter 10, page 410

The **timing disc** is known as an armature, reluctor, trigger wheel, pulse wheel, or timing core. It is used to conduct lines of magnetic force.

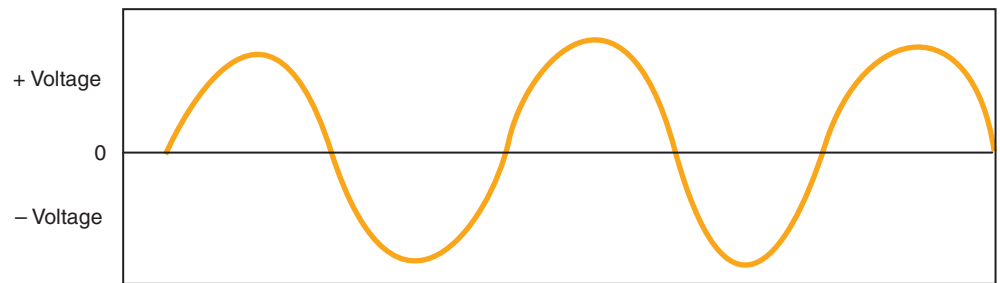
The **pickup coil** is also known as a stator, sensor, or pole piece.





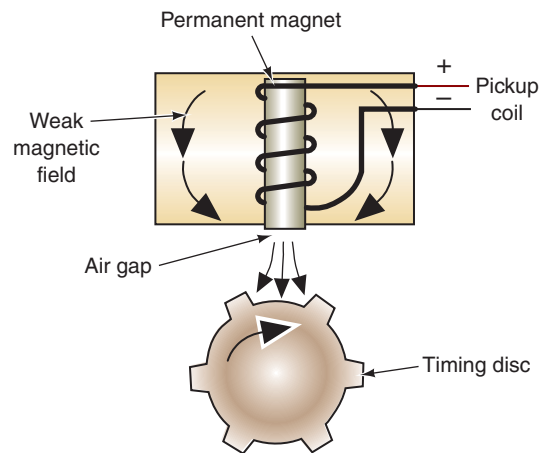
© Delmar/Cengage Learning

**FIGURE 10-15** Components of the magnetic pulse generator. A strong magnetic field is produced in the pick-up coil as the teeth align with the core.



© Delmar/Cengage Learning

**FIGURE 10-16** Pulse signal sine wave.

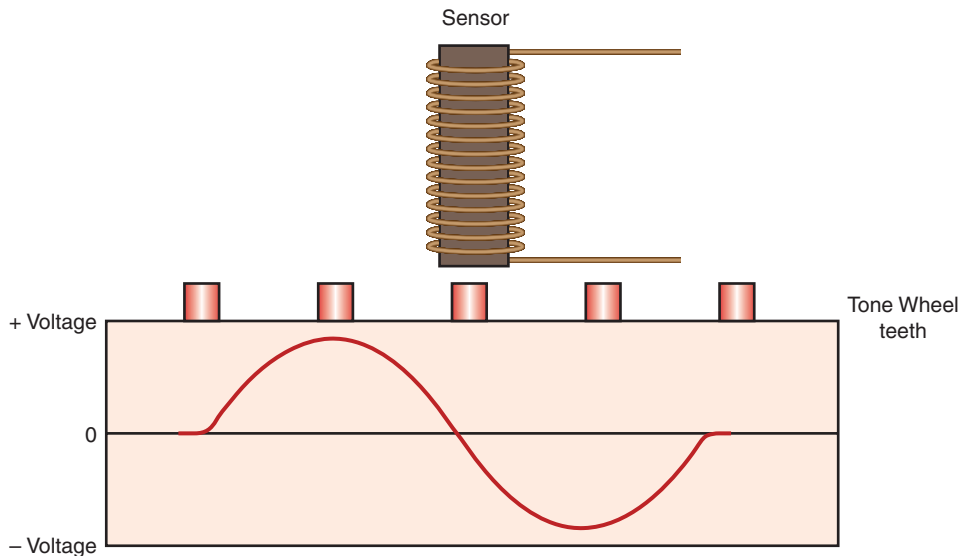


© Delmar/Cengage Learning

**FIGURE 10-17** The magnetic field expands as the teeth pass the core.

(Figure 10-17). The expanding magnetic field cuts across the windings of the pickup coil. This movement of the magnetic field induces a voltage in the windings. This action is repeated every time a tooth passes the core. The moving lines of magnetic force cut across the coil windings and induce a voltage signal.

When a tooth approaches the core, a positive current is produced as the magnetic field begins to concentrate around the coil (Figure 10-18). The voltage will continue to climb as



© Delmar/Cengage Learning

**FIGURE 10-18** A positive voltage swing is produced as the tooth approaches the core. When the tooth aligns with the core, there is no magnetic movement and no voltage. A negative wave form is created as the tooth passes the core.

long as the magnetic field is expanding. As the tooth approaches the magnet, the magnetic field gets smaller, causing the induced voltage to drop off. When the tooth and core align, there is no more expansion or contraction of the magnetic field (thus no movement) and the voltage drops to zero. When the tooth passes the core, the magnetic field expands and a negative current is produced. The resulting pulse signal is amplified, digitalized, and sent to the microprocessor.

**AUTHOR'S NOTE:** The magnetic pulse (PM) generator operates on basic magnetic principles. Remember that a voltage can only be induced when a magnetic field is moved across a conductor. The magnetic field is provided by the pickup unit, and the rotating timing disc provides the movement of the magnetic field needed to induce voltage.

## Magnetoresistive Sensor

**Magnetoresistive (MR) sensors** consist of the magnetoresistive sensor element, a permanent magnet, and an integrated signal conditioning circuit to make use of the **magnetoresistive effect**. This effect defines that if a current carrying magnetic material is exposed to an external magnetic field its resistance characteristics will change. This results in the resistance of the sensing element being a function of the direction and intensity of an applied magnetic field. Magnetoresistive sensors cannot generate a signal voltage on their own, and must

**Shop Manual**  
Chapter 10, page 413

**AUTHOR'S NOTE:** The magnetoresistive principle provides rotational speed measurements down to zero. For this reason they are sometimes called "zero speed sensors."

have an external power source. The magnetoresistive bridge changes resistance due to the relationship of the tone wheel and magnetic field surrounding the sensor.

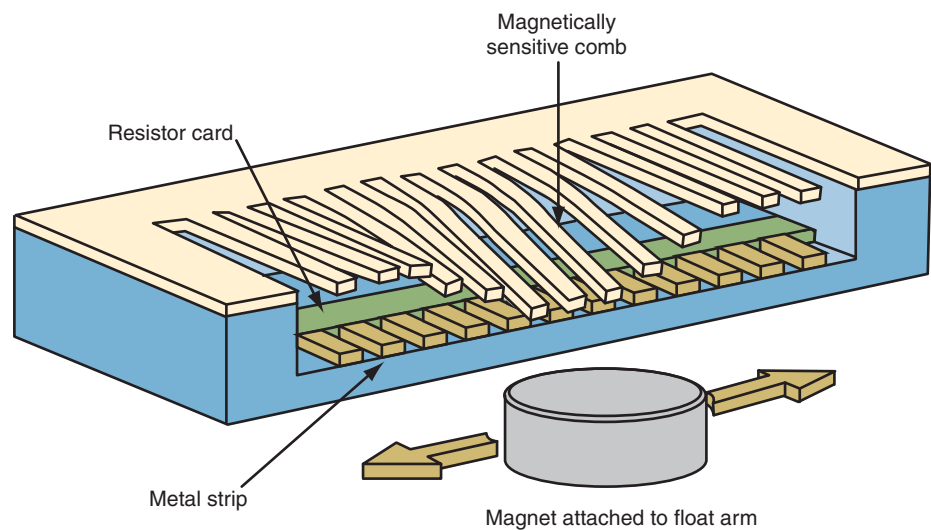
## Magnetically Coupled Linear Sensors

Linear sensors are used for such functions such as fuel level sending units. The most common type of fuel level sensor is a rheostat style with wire wound resistor and a movable wiper. The wiper is in constant contact with the winding and may eventually rub through the wire. Many manufacturers are now using **magnetically coupled linear sensors** that are not prone to the wear (Figure 10-19).

Magnetically coupled linear sensors used for fuel level sensing have a magnet attached to the end of the float arm. Also a resistor card and a magnetically sensitive comb are located next to the magnet. When the magnetic field passes the comb, the fingers are pulled against the resistor card contacting resistors that represent the various levels of fuel (Figure 10-20).



**FIGURE 10-19** Magnetically coupled linear sensor used to measure fuel level.



**FIGURE 10-20** Comb design magnetic sensor pulls the fingers against the resistor card.

When the tank is full, the float is on top along with the magnet. As the fuel level falls, the float drops and the position of the magnet changes. The magnet is so close to the sensor that it attracts the closest metal fingers. The fingers contact a metal strip. Different contact sites on the strip produce different resistances that are used to determine the fuel level.

## Hall-Effect Sensors

Based on the principle that if a current is allowed to flow through thin conducting material that is exposed to a magnetic field, another voltage is produced (Figure 10-21). The switch contains a permanent magnet, a thin semiconductor layer made of gallium arsenate crystal (Hall layer), and a **shutter wheel** (Figure 10-22). The Hall layer has a negative and a positive

**Shop Manual**  
Chapter 10, page 416

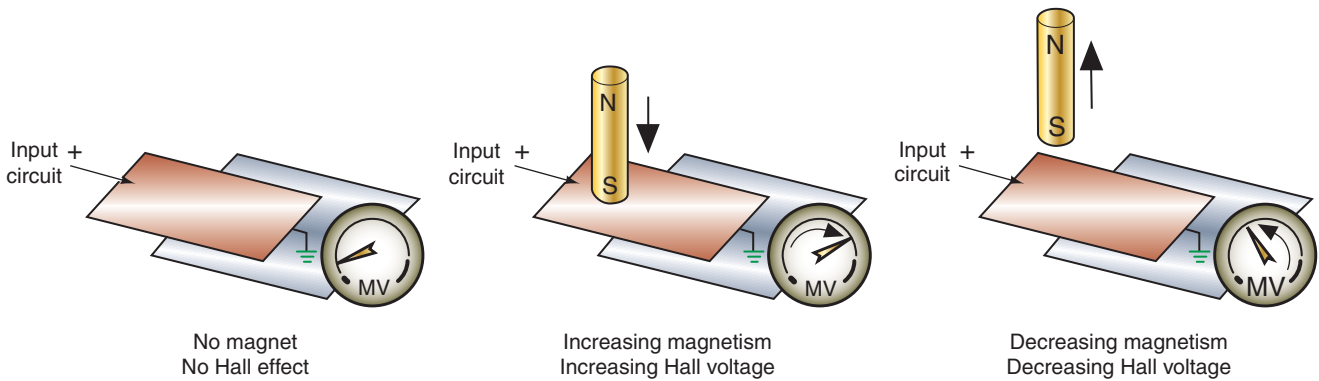


FIGURE 10-21 Hall-effect principles of voltage induction.

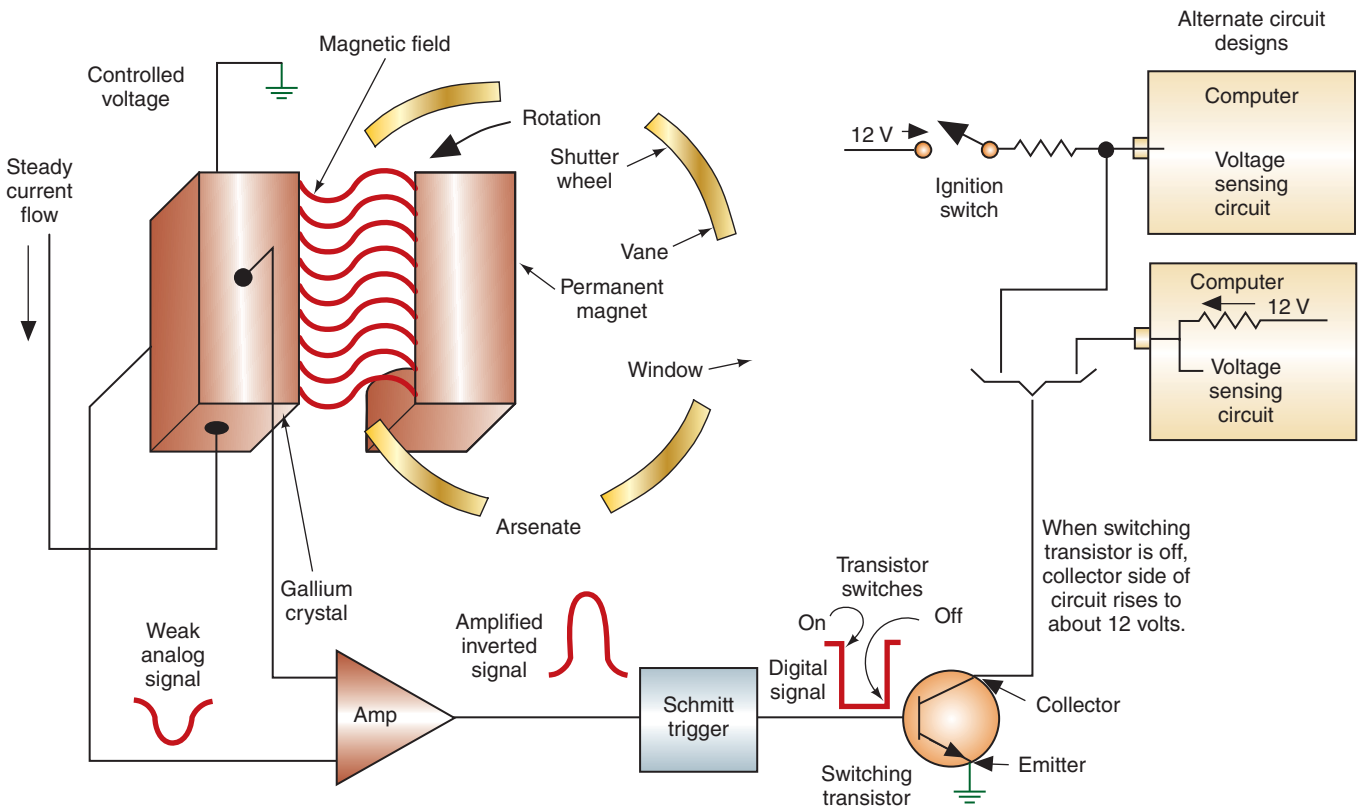
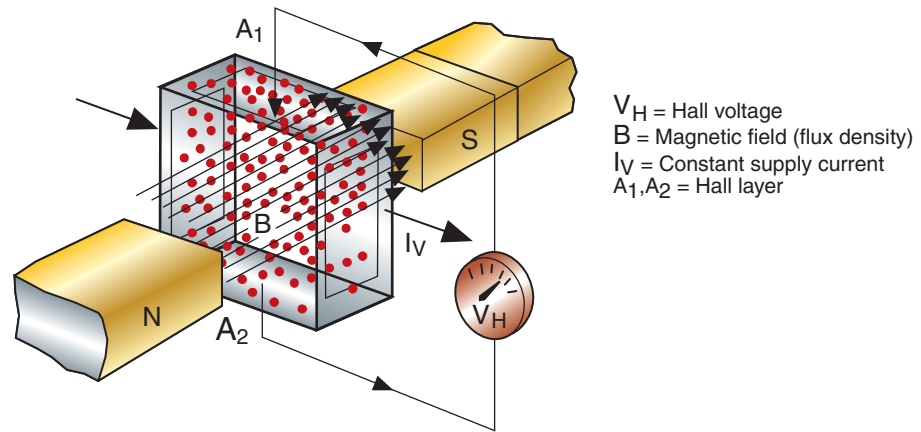


FIGURE 10-22 Typical circuit of a Hall-effect switch.

© Delmar/Cengage Learning



© Delmar/Cengage Learning

**FIGURE 10-23** The magnetic field causes the electrons from the supply current to gather at the Hall layer negative terminal. This creates a voltage potential.

terminal connected to it. Two additional terminals located on either side of the Hall layer are used for the output circuit. The shutter wheel consists of a series of alternating windows and vanes. It creates a magnetic shunt that changes the strength of the magnetic field from the permanent magnet.

The permanent magnet is located directly across from the Hall layer so that its lines of flux will bisect at right angles to the current flow. The permanent magnet is mounted so that a small air gap is between it and the Hall layer.

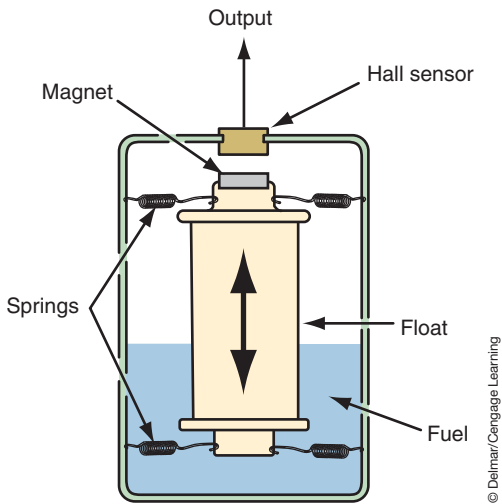
A steady current is applied to the crystal of the Hall layer. This produces a signal voltage that is perpendicular to the direction of current flow and magnetic flux. The signal voltage produced is a result of the effect the magnetic field has on the electrons. When the magnetic field bisects the supply current flow, the electrons are deflected toward the Hall layer negative terminal (Figure 10-23). This results in a weak voltage potential being produced in the Hall switch.

A shutter wheel is attached to a rotational component. As the wheel rotates, the shutters (vanes) will pass in this air gap. When a shutter vane enters the gap, it intercepts the magnetic field and shields the Hall layer from its lines of force. The electrons in the supply current are no longer disrupted and return to a normal state. This results in low voltage potential in the signal circuit of the Hall switch.

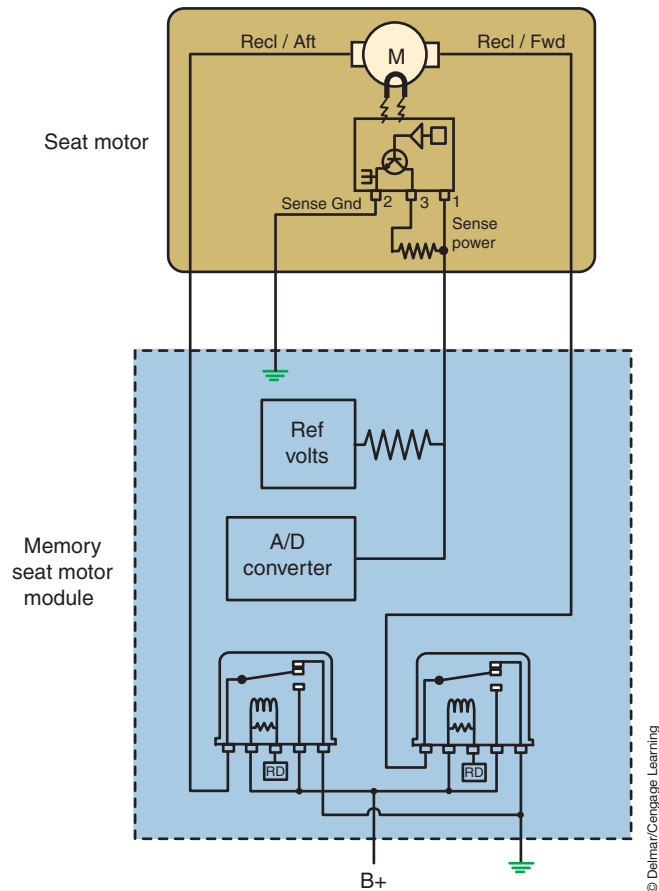
The signal voltage leaves the Hall layer as a weak analog signal. To be used by the computer, the signal must be conditioned. It is first amplified because it is too weak to produce a desirable result. The signal is also inverted so that a low input signal is converted into a high output signal. It is then sent through a **Schmitt trigger** where it is digitized and conditioned into a clean square wave signal. The signal is finally sent to a switching transistor. The computer senses the turning on and off of the switching transistor to determine the frequency of the signals and calculates speed.

The Hall-effect just discussed describes its usage as a switch. It can also be designed as an analog (or linear) sensor that produces an output voltage that is proportional to the applied magnetic field. This makes them useful for determining to position of a component instead of just rotation. For example, this type of sensor can be used to monitor fuel level or to track seat positions in memory seat systems.

A fuel level indication can be accomplished with a Hall-effect sensor by attaching a magnet to the float assembly (Figure 10-24). As the float moves up and down with the fuel level, the gap between the magnet and the Hall element will change. The gap changes the Hall-effect and thus the output voltage.



**FIGURE 10-24** Hall-effect sensor used for fuel level indication.



**FIGURE 10-25** Two-wire linear Hall-effect sensor.

As discussed, typical Hall-effect sensors and switches use three wires. However, linear Hall-effect sensors can also be constructed using two wire circuits (Figure 10-25). This is common on systems that use a DC motor drive. The reference voltage to the sensor is supplied through a pull-up resistor. Typically this reference voltage will be 12 volts. Whenever the motor is operated the reference voltage will be applied. After the motor is turned off, this reference voltage will remain for a short time.

Internal to the motor assembly is a typical three terminal Hall sensor. The reference voltage is supplied to terminal 1 of the Hall sensor. A pull-up resistor also connects the reference voltage to terminal 3 of the Hall sensor. This becomes the signal circuit. The two pull-up resistors will be of equal value. Terminal 2 of the Hall sensor is connected to the sensor return circuit. A magnet is attached to the motor armature to provide a changing magnetic field once per motor revolution.

When the Hall sensor is off the voltage supplied to the Hall sensor will be near that of the source voltage. Since this is an open circuit condition in the Hall sensor at terminal 3, the voltage drop over the signal circuit pull-up resistor will be 0.

When the motor rotates and the influence of the magnetic field turns on the Hall sensor, the signal terminal 3 is connected to ground within the sensor. This pulls the signal voltage low and results in the formation of a series circuit from the reference supply to terminal 3. Since each of the pull-up resistors are equal the voltage drop will be split between the two. Approximately half the voltage will be dropped across the pull-up resistor in the computer and the other half over the pull-up resistor in the motor assembly. The Hall-effect sensor will remain powered since the reference voltage to terminal 1 is connected between the two resistors and the 6 volts on the circuit is sufficient to operate the sensor.



### A BIT OF HISTORY

The American physicist, Edwin Herbert Hall (1855–1938), discovered the principle of the Hall-effect switch in 1879.



G force is used to describe the measurement of the net effect of the acceleration that an object experiences and the acceleration that gravity is trying to impart to it. Basically G force is the apparent force that an object experiences due to acceleration.

## Accelerometers

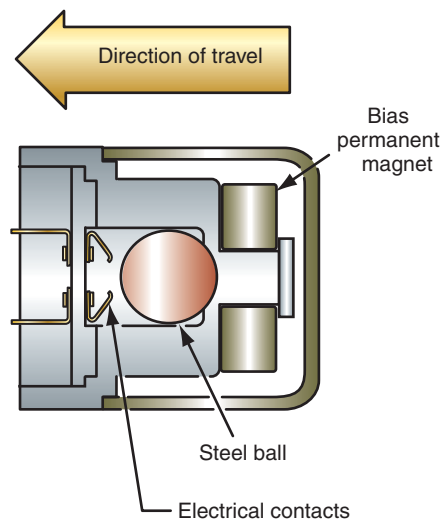
**Accelerometers** are sensors designed to measure the rate of acceleration or deceleration. Common sensors include mass-type, roller-type, and solid state accelerometers. The first extensive use of the accelerometer was in the airbag system. The use of accelerometers has expanded greatly in today's vehicles. They are now used on vehicle stability systems, roll over mitigation, hill hold control, electronic steering, and navigational systems. These sensors may perform specific functions other than forward acceleration and deceleration forces. For example they will operate as a gyro to determine direction change and rotation.

Accelerometers react to the amount of **G force** associated with the rate of acceleration or deceleration. In airbag systems they are used to determine deceleration forces that indicate the vehicle has been involved in a collision that requires the airbag to be deployed.

Early accelerometers used in airbag systems were electromechanical designs. The mass-type sensor contains a normally open set of gold-plated switch contacts and a gold-plated ball that acts as a sensing mass (Figure 10-26). The gold-plated ball is mounted in a cylinder coated with stainless steel. A magnet holds the ball away from the contacts. When the vehicle is involved in a frontal collision of sufficient force, the sensing mass (ball) moves forward in the sensor and closes the switch contacts.

In many air bag systems, solid-state accelerometers are used to sense deceleration forces. The piezoelectric accelerometer generates an analog voltage proportional to a G force. The accelerometer contains a piezoelectric element that is distorted during a high G force condition and generates an analog voltage in relation to the force. The analog voltage from the piezoelectric element is sent to a collision-judging circuit in the airbag computer. If the collision impact is great enough, the computer deploys the air bag.

Accelerometers can also be designed as piezoresistive sensors that use a silicon mass that is suspended from four deflection beams. The deflection beams are the strain sensing elements. The four strain elements are in a Wheatstone bridge circuit. The strain elements on the beam generate a signal that is proportional to the G forces. The resistance changes over the bridge are interpreted by an internal chip that then communicates the status to the control module using a frequency modulated digital pulse.



© Delmar/Cengage Learning

**FIGURE 10-26** Sensing mass held by a magnet will break loose if deceleration forces are severe enough.

## SWITCH INPUTS

Switches are simplest of all input devices. The computer monitors the two states of the switch by measuring the voltage on the sense circuit. There are two types of voltage sensing circuits used with switches; the **pull-down circuit** and the **pull-up circuit**. Basically, the pull-down circuit will close the switch to ground and the pull-up circuit will close the switch to voltage.

A pull-down voltage sense circuit usually uses an internal voltage source within the computer (Figure 10-27). It is also possible to use an external voltage source (Figure 10-28). The current limiting resistor is used to protect the computer and the circuit. It also prevents input values from **floating**. Floating occurs when the switch is open resulting in the input to the voltage sense circuit of the control module being susceptible to electrical noise that may cause the control module to misread the switch state. The current limiting resistor used in the circuit is referred to as a **pull-up resistor** since it assures the proper high voltage reading by connecting the voltage sense circuit to an electrical potential that can be removed when the switch is closed.

The pull-up resistor is usually of a very high ohms value to keep amperage to a minimum. This resistor can have a value of 10K to 10M ohms. When the switch is open, there is no current flow through the resistor and no voltage drop over it. This results in the voltage sense circuit recording a value equal to the reference voltage. When the switch is closed, current flows through the resistor and results in a voltage drop. Since the switch should provide a clean contact to ground, the voltage sense circuit should read a value close to 0 volts.

The pull-up circuit will have a reference voltage through the switch (Figure 10-29). Usually the reference voltage will be provided directly from the battery or by the ignition switch. The current limiting resistor performs the same function in this circuit as it does in the pull-down circuit. This resistor is referred to as a **pull-down resistor** since it assures a proper low voltage reading by preventing float when the switch is open. With the switch in the open position the voltage sense circuit will read 0 volts. With the switch closed, the sense circuit should read close to reference voltage.

Both of these circuits are limited concerning the ability to determine circuit faults. Since there are only two states for the switch, there are two voltage values that the computer expects to see. An open or short to ground will not produce an unexpected voltage value, but will result in improper system operation. However, the computer may be capable of determining an functionality problem with the input circuit if the seen voltage is implausible for the conditions. For example, if the switch is an operator activated switch that requests A/C operation and the voltage indicates that the switch may be stuck the computer can set a stuck switch DTC and ignore the input.

To provide continuity diagnostics, the circuit may have a diagnostic resistor wired parallel to the switch (Figure 10-30). The computer will be able to recognize three different

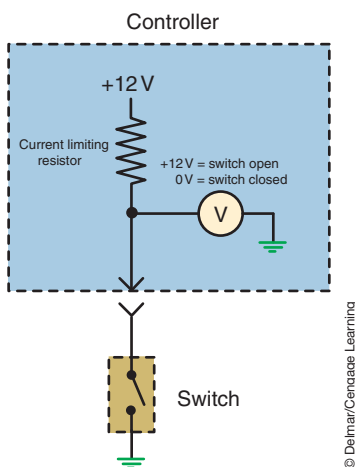


FIGURE 10-27 Pull-down switch circuit.

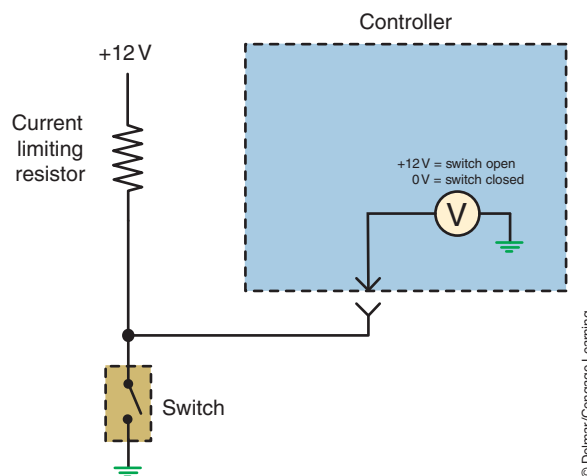


FIGURE 10-28 Pull-down switch circuit with external voltage source.

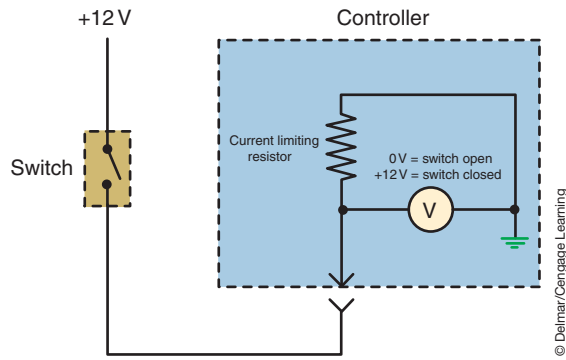


FIGURE 10-29 Pull-up switch circuit.

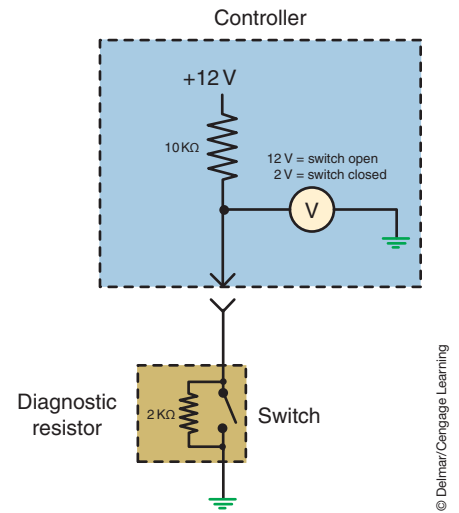


FIGURE 10-30 Pull-down circuit with a diagnostic resistor.

voltage values. In the example, the current limiting resistor has a value of 10K ohms while the diagnostic resistor has a value of 2K ohms. With the switch in the open state, the voltage sense circuit would read 10 volts. With the switch closed the voltage read will be close to 0 volts. A reading of 12 volts would indicate an open in the circuit.

Another typical type of switch that is used is the resistive multiplex switch. This switch is used to provide multiple inputs from a single switch using one circuit (Figure 10-31). The

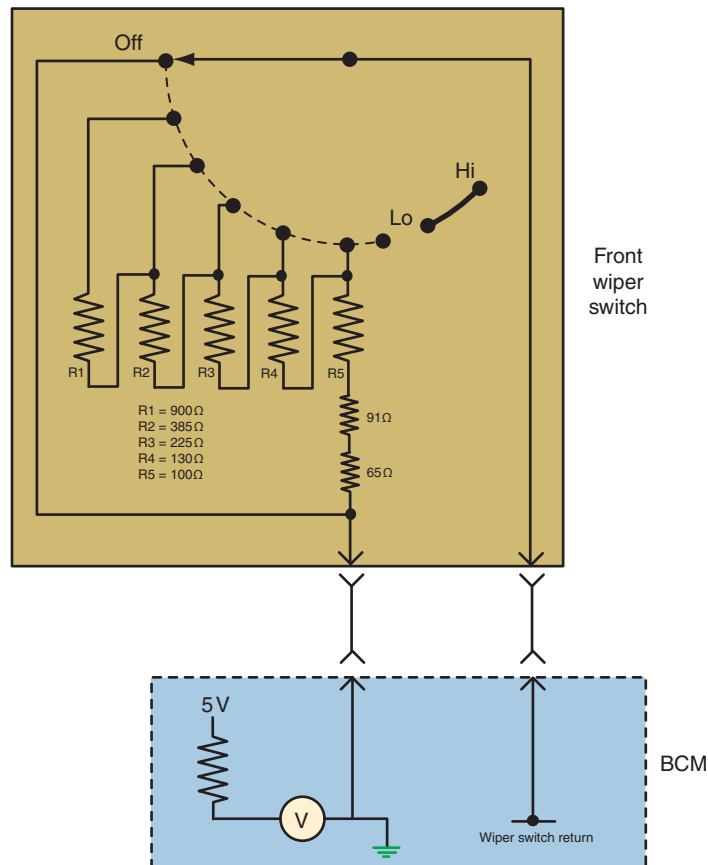
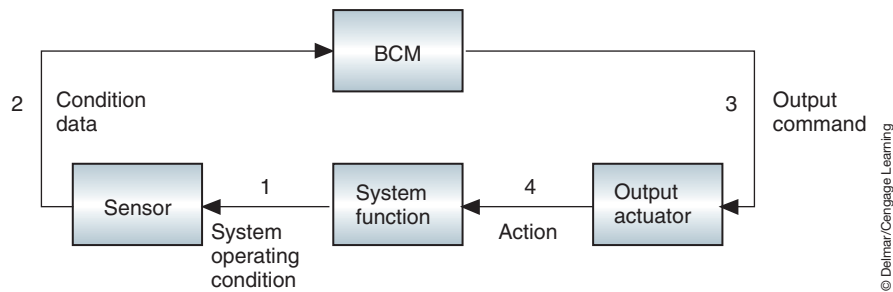


FIGURE 10-31 Resistive multiplex switch.



**FIGURE 10-32** Principle of feedback signals.

© Delmar/Cengage Learning

control module sends a signal voltage to the switch through a fixed resistor. Each switch position has an unique resistance value that will be placed in series with the resistor in the control module. As different switch positions are selected, a different amount of voltage is dropped over the fix resistor in the control module and the sensed voltage level changes. Based on the sensed voltage value, the control module interprets what operation the driver is requesting.

## FEEDBACK SIGNALS

If the computer sends a command signal to open a blend door in an automatic climate control system, a **feedback** signal may be sent back from the actuator to inform the computer the task was performed. The feedback signal will confirm both the door position and actuator operation (Figure 10-32). Another form of feedback is for the computer to monitor voltage as a switch, relay, or other actuator is activated. Changing states of the actuator will result in a predictable change in the computer’s voltage sensing circuit. The computer may set a diagnostic code if it does not receive the correct feedback signal.

## SUMMARY

- Inputs provide the computer with system operation information or driver requests.
- Driver input signals are usually provided by momentarily applying a ground through a switch.
- Switches can be used as an input for any operation that only requires a yes–no, or on–off, condition.
- Sensors convert some measurement of vehicle operation into an electrical signal. There are many different designs of sensors: thermistors, Wheatstone bridge, potentiometers, magnetic pulse generator, and Hall-effect switches.
- A thermistor is a solid-state variable resistor made from a semiconductor material that changes resistance in relation to temperature changes.
- Negative temperature coefficient (NTC) thermistors reduce their resistance as the temperature increases.
- Positive temperature coefficient (PTC) thermistors increase their resistance as the temperature increases.
- Some temperature sensing circuits are designed as dual range circuits to provide more accurate temperature measurements.
- Pressure switches will usually use a diaphragm that works against a calibrated spring or other form of tension. When pressure is applied to the diaphragm that is of a sufficient value to overcome the spring tension a switch is closed.

## SUMMARY

---

### TERMS TO KNOW

Accelerometers  
Capacitance discharge sensor  
Dual range  
Feedback  
Floating  
Hall-effect switch  
Linearity  
Magnetically coupled linear sensors  
Magnetic pulse generators  
Magnetoresistive effect  
Magnetoresistive (MR) sensors  
Negative temperature coefficient (NTC) thermistors  
Permalloy  
Pickup coil  
Piezoelectric device  
Piezoresistive device  
Potentiometer  
Potentiometric pressure sensors  
Positive temperature coefficient (PTC) thermistors  
Pull-down circuit  
Pull-down resistor  
Pull-up circuit  
Pull-up resistor  
Schmitt trigger  
Sensors  
Shutter wheel  
Strain gauge  
Thermistor  
Timing disc  
Wheatstone bridge

- A strain gauge sensor determines the amount of applied pressure by measuring the strain a material experiences when subjected to the pressure.
- Piezoresistive devices are similar to variable resistors whose resistance values change as the pressure applied to the crystal changes.
- The Wheatstone bridge is a series-parallel arrangement of resistors between an input terminal and ground.
- Piezoelectric devices are voltage generators with a resistor connected in series that is used to measure fluid and air pressures.
- The capacitance discharge sensor uses a variable capacitor constructed of two flexible alumina plates that are separated by an insulating washer. As the distance between the electrodes changes, so does the capacity of the capacitor. A measure of capacitance constitutes a measurement of pressure that is detected by a bridge circuit.
- A potentiometer is a variable resistor that usually consists of a wire wound resistor with a moveable center wiper.
- Magnetic pulse generators use the principle of magnetic induction to produce a voltage signal and are commonly used to send data concerning the speed of the monitored component to the computer.
- Magnetoresistive (MR) sensors consist of the magnetoresistive sensor element, a permanent magnet, and an integrated signal conditioning circuit to change resistance due to the relationship of the tone wheel and magnetic field surrounding the sensor.
- Magnetically coupled linear sensors use a moveable magnet that is attached to the measured element, a resistor card, and a magnetically sensitive comb. When the magnetic field passes the comb, the fingers are pulled against the resistor card contacting resistors that represent the various positions of the measured element.
- Hall-effect switches operate on the principle that if a current is allowed to flow through thin conducting material that is exposed to a magnetic field, another voltage is produced.
- The Hall-effect can also be designed as an analog (or linear) sensor that produces an output voltage that is proportional to the applied magnetic field.
- Accelerometers are sensors designed to measure the rate of acceleration or deceleration. Accelerometers react to the amount of G force associated with the rate of acceleration or deceleration.
- The piezoelectric accelerometer generates an analog voltage proportional to a G force.
- Accelerometers can also be designed as piezoresistive sensors.
- The pull-down circuit will close the switch to ground.
- The pull-up circuit will close the switch to voltage.
- The pull-up resistor assures the proper high voltage reading by connecting the voltage sense circuit to an electrical potential that can be removed when the switch is closed.
- The pull-down resistor assures a proper low voltage reading by prevent float when the switch is open.
- The resistive multiplex switch is used to provide multiple inputs from a single switch using one circuit.
- Feedback signals are used to confirm position and operation of an actuator.

## REVIEW QUESTIONS

---

### Short-Answer Essays

1. What is the function of input devices?
2. Explain the purpose of the thermistor and how it is used in a circuit.
3. Describe the operation and purpose of the Wheatstone Bridge.
4. Explain the operation and purpose of piezoelectric devices.
5. What is the difference between NTC and PTC thermistors?
6. How does the Hall-effect switch generate a voltage signal?
7. Describe the basic function of a stepper motor.
8. What is meant by feedback as it relates to computer control?
9. Describe the operation of the pull-down sense circuit.
10. Describe the operation of the pull-up sense circuit.

### Fill in the Blanks

1. The piezoelectric accelerometer generates an analog voltage proportional to a \_\_\_\_\_.
2. The \_\_\_\_\_ resistor assures the proper high voltage reading by connecting the voltage sense circuit to an electrical potential that can be removed when the switch is closed.
3. The resistive multiplex switch is used to provide multiple inputs from a single switch using \_\_\_\_\_ circuit.
4. Magnetoresistive (MR) sensors consist of the magnetoresistive sensor element, a permanent magnet, and an integrated signal conditioning circuit to change \_\_\_\_\_ due to the relationship of the tone wheel and magnetic field surrounding the sensor.
5. The capacitance discharge sensor changes its capacitance by the difference in \_\_\_\_\_ between the electrodes.
6. \_\_\_\_\_ convert some measurement of vehicle operation into an electrical signal.
7. Negative temperature coefficient (NTC) thermistors \_\_\_\_\_ their resistance as the temperature increases.
8. \_\_\_\_\_ switches operate on the principle that if a current is allowed to flow through thin conducting material exposed to a magnetic field, another voltage is produced.
9. Magnetic pulse generators use the principle of \_\_\_\_\_ to produce a voltage signal.
10. \_\_\_\_\_ means that data concerning the effects of the computer's commands are fed back to the computer as an input signal.

## MULTIPLE CHOICE

---

1. All of the following can be used to measure movement or position, EXCEPT:
  - A. Potentiometer
  - B. Magnetic pulse generator
  - C. Piezoelectric device
  - D. Hall-effect sensor
2. *Technician A* says the piezoresistive sensor changes resistance as a function of temperature. *Technician B* says the piezoresistive sensor outputs its own current based on the pressure it is exposed to. Who is correct?
  - A. A only
  - B. B only
  - C. Both A and B
  - D. Neither A nor B
3. The Wheatstone bridge is:
  - A. A pressure sensing device that uses a variable capacitor.
  - B. A pressure sensing device that uses varying resistances in a series-parallel circuit design.
  - C. Used to measure motion by use of magnetic inductance
  - D. None of the above.



4. The piezoelectric sensor operates by:
- Altering the resistance values of the bridge circuit located on a ceramic disc.
  - Dropping voltage over a fixed resistor as pressure is applied to the switching transistor.
  - Generating a voltage within a thin ceramic disc voltage generator that is attached to a diaphragm that stress the crystals in the disc.
  - None of the above.
5. Capacitance discharge sensors are being discussed. *Technician A* says the size of the electrodes alters as the sensing element is exposed to different pressures. *Technician B* says the distance between the electrodes alters as the sensing element is exposed to different pressures. Who is correct?
- A only
  - B only
  - Both A and B
  - Neither A nor B
6. *Technician A* says a potentiometer is a voltage divider circuit used to measure movement of a component, *Technician B* says a magnetoresistive sensor alters current flow through the sense circuit when influenced by the magnetic field. Who is correct?
- A only
  - B only
  - Both A and B
  - Neither A nor B
7. *Technician A* says negative temperature coefficient thermistors reduce their resistance as the temperature decreases. *Technician B* says positive temperature coefficient thermistors increase their resistance as the temperature increases. Who is correct?
- A only
  - B only
  - Both A and B
  - Neither A nor B
8. *Technician A* says magnetic pulse generators are commonly used to send data to the computer concerning the speed of the monitored component. *Technician B* says an on-off switch sends a digital signal to the computer. Who is correct?
- A only
  - B only
  - Both A and B
  - Neither A nor B
9. Speed sensors are being discussed. *Technician A* says the timing disc is stationary and the pickup coil rotates in front of it. *Technician B* says the number of pulses produced per mile increases as rotational speed increases. Who is correct?
- A only
  - B only
  - Both A and B
  - Neither A nor B
10. *Technician A* says a Hall-effect switch uses a steady supply current to generate a signal. *Technician B* says a Hall-effect switch consists of a permanent magnet wound with a wire coil. Who is correct?
- A only
  - B only
  - Both A and B
  - Neither A nor B

## VEHICLE COMMUNICATION NETWORKS

### UPON COMPLETION AND REVIEW OF THIS CHAPTER, YOU SHOULD BE ABLE TO UNDERSTAND AND DESCRIBE:

- The principle of multiplexing.
- The different OBD II multiplexing communication protocols.
- The different classes of communications.
- The operation of a class A multiplexing system.
- The operation of a class B multiplexing system.
- The operation of the Controller Area Network (CAN) bus system.
- The purpose and operation of different supplemental data bus networks.
- The operation of the Local Interconnect Network (LIN) data bus system.
- The operation of the Media Oriented System Transport (MOST) data bus using fiber optics.
- The operation of wireless networks using Bluetooth technology.

### INTRODUCTION

In the past, if an accessory was added to the vehicle that required input information from sensors, either additional sensors had to also be added or the new accessory would have to be spliced into an existing sensor circuit. Either way, the cost of production was increased due to added components and wiring. For example, some early vehicles were equipped with as many as three engine coolant temperature sensors. One sensor was used by the powertrain control module (PCM) for fuel and ignition strategies, the other was used by the cooling fan module to operate the radiator fans at the correct speed based on temperature, and the third was used by the instrument cluster for temperature gauge operation.

Today vehicle manufacturers will use **multiplexing (MUX)** systems to enable different control modules to share information. Multiplexing provides the ability to use a single circuit to distribute and share data between several control modules throughout the vehicle. Because the data is transmitted through a single circuit, bulky wiring harnesses are eliminated. A MUX wiring system uses bus data links that connect each module and allow for the transporting of data from one module to another. Each module can transmit and receive digital codes over the bus data links. Each computer connected to the data bus is called a **node**. The signal sent from a sensor can go to any of the modules and can be used by the other modules. Before multiplexing, if information from the same sensing device was needed by several controllers, a wire from each controller needed to be connected in parallel to that sensor. If the sensor signal was analog, the controllers needed an analog to digital (A/D) convertor to be able to “read” the sensor information. By using multiplexing, the need for separate conductors from the sensor to each module is eliminated and the number of drivers in the controllers is reduced.

As discussed in Chapter 9, binary code is sent by digital signals to the nodes. The nodes use this code to communicate messages, both internally and with other controllers. A chip is used to prevent the digital codes from overlapping by allowing only one code to be transmitted at a time. Each digital message is preceded by an identification code that establishes its priority. If two modules attempt to send a message at the same time, the message with the higher priority code is transmitted first.

The major difference between a multiplexed system and a nonmultiplexed system is the way data is gathered and processed. In nonmultiplexed systems, the signal from a sensor is sent as an analog signal through a dedicated wire to the computer or computers. At the computer, the signal is changed from an analog to a digital signal. Because each sensor requires its own dedicated signal wire, the number of wires required to feed data from all of the sensors and transmit control signals to all of the output devices is great.

In a MUX system, the signal is sent to a computer where it is converted from analog to digital if needed. Since the computer or control module of any system can process only one input at a time, it calls for input signals as it needs them. By timing the transmission of data from the sensors to the control module, a single data circuit can be used. Between each transmission of data to the control module, the sensor is electronically disconnected from the control module.

## MULTIPLEXING COMMUNICATION PROTOCOLS

A **protocol** is a language computers use to communicate with one another over the data bus. Protocols may differ in baud rate and in the method of delivery. For example, some manufacturers use pulse width modulation while others use variable pulse width. In addition, there may be differences in the voltage levels that equal a 1 or a 0.

The Society of Automotive Engineers (SAE) has defined different classes of protocols according to their **baud rate** (speed of communication):

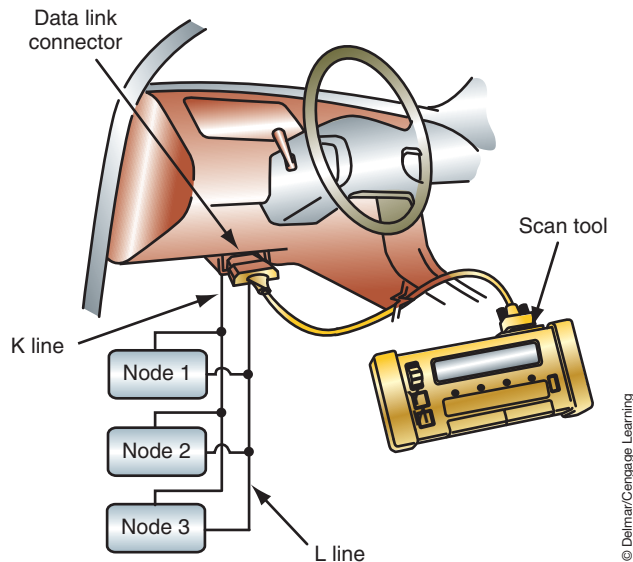
- Class A—Generic Universal **Asynchronous** Receiver/Transmitter (UART) low-speed protocol that has a baud rate of up to 10 Kb/s (10,000 bits per second). Asynchronous protocol means that the communication between nodes is done only when needed instead of continuously.
- Class B—Medium-speed protocol that has a baud rate between 10 Kb/s and 125 Kb/s.
- Class C—A high-speed protocol with a baud rate between 125 Kb/s and 1000 Kb/s, used for functions that require real-time control.

Newer automotive protocols fall under on-board diagnostics, second generation (OBD II) requirements. The SAE has adopted the OBD II protocol as the class B standard protocol (Figure 11-1).

ISO 9141-2 (K-line)
ISO 14230-4 (Keyword protocol (Kwp) 2000)
J 1850 10.4 Kb/s Variable pulse width
J 1850 41.6 Kb/s Pulse width modulated
J 2284/ISO 15765-4 Controller area network (CAN)

© Delmar/Cengage Learning

**FIGURE 11-1** OBD II communication protocols.



**FIGURE 11-2** The two-wire ISO 9141-2 data bus used for diagnostic purposes.

## ISO 9141-2 Protocol

The International Standards Organization (ISO) protocol known as the **ISO 9141-2** is a class B system with a baud rate of 10.4 Kb/s. ISO 9141-2 is not a network protocol since it can only be used for diagnostic purposes. ISO 9141 standardizes a protocol to be used between the nodes on the data bus and an OBD II standardized scan tool (as per SAE J1978 standards) for diagnostic purposes. This system is a two-wire system (Figure 11-2). One wire is called the **K-line** and is used for transmitting data from the module to the scan tool. The scan tool provides the bias voltage onto this circuit and the module pulls the voltage low to transmit its data. The other wire is called the **L-line** and is used by the module to receive data from the scan tool. The module provides the bias onto this circuit and the scan tool pulls the voltage low to communicate.

An adoption of the ISO 9141-2 protocol is the **ISO-K** bus that allows for bidirectional communication on a single wire. Vehicles that use the ISO-K bus require that the scan tool provide the bias voltage to power up the system. The scan tool provides up to 12 volts onto the circuit, and the data is transferred when the voltage is pulled low to create a digital signal (Figure 11-3). The actual voltage seen on the circuit can be a little less than 12 volts, based on the number of modules in the circuit.

## ISO 14230-4 Protocol

The **ISO 14230-4** protocol uses a single-wire bidirectional data line to communicate between the scan tool and the nodes. This system is used by many European manufacturers. This data bus is only used for diagnostics and maintains the ISO 9141 protocol with a baud rate of 10.4 Kb/s. The operation of receive and transmit is similar to the UART system since communication requires a **master module**. The master module controls the transportation of messages by polling all of the **slave modules** and then waiting for the response. The communication occurs as the voltage on the wire is pulled low at a fixed pulse width. When there is no communication occurring, the voltage on the line will be 5 volts.

## J1850 Protocol

The **J1850** bus system is the class B standard for OBD II. The J1850 standard allows for two different versions based on baud rate. The first supports a baud rate of 41.6 Kb/s. Ford uses this protocol and calls it the Standard Corporate Protocol (SCP). This system uses a pulse width

**Shop Manual**  
Chapter 11, page 448

Biasing refers to the voltage supplied to the bus.

**ISO 14230-4** is also called Keyword Protocol 2000 or KWP2000.

**Shop Manual**  
Chapter 11, page 454



**FIGURE 11-3** ISO K data bus transmission voltages.

modulated (PWM) signal that is transferred using a twisted pair of wires. The second protocol supports a baud rate of 10.4 Kb/s average. General Motors and Chrysler have adopted this protocol. General Motors calls their system Class 2 and Chrysler calls theirs Programmable Communication Interface (PCI). These systems use a variable pulse width (VPW) data bus with a single wire. This system will be discussed in great detail later in this chapter.

### J2284/ISO 15765-4 Protocol

The principal class C protocol is J2284. This system is referred to as **Controller Area Network (CAN)**. The CAN network system can support baud rates up to 1 Mb/s and is designed for real-time control of specific systems. Robert Bosch developed CAN in the early 1980s, and it has been a very popular bus system in Europe. Until recently most CAN bus-equipped vehicles used the CAN bus for communications between modules only and not for diagnostics with a scan tool. Scan tool diagnostics are usually performed over the ISO-K bus.

New U.S. regulations are requiring the use of the CAN bus system under industry standard J2284. This is the protocol for communications with a scan tool on U.S.-sold vehicles. Although the CAN bus system has been used since the 1980s, J2284 makes it unique in that it will be used for diagnostics. Manufacturers will be required to use CAN for 2008 model year vehicles. This system will be discussed in greater detail later in this chapter.

**YOU SHOULD KNOW:** As a vehicle bus system, the CAN bus is not a legislated system. The SAE has mandated the CAN C network as the protocol for scan tool communications to the PCM. Thus manufacturers can continue to use any system they wish for vehicle communications.

### MULTIPLEXING SYSTEMS

The following are some examples of how data bus messages are transmitted. Although protocols are in place, manufacturers have some freedom to design the system they wish to use. The following examples will explain the common methods that are employed.

## Class A Data Bus Network

One of the earliest multiplexing systems was developed by Chrysler in 1988 and used through the 2003 model year. This system is called **Chrysler Collision Detection (CCD)**. The term *collision* refers to the collision of data occurring simultaneously. This bus circuit uses two wires. The advantages of the CCD system include:

1. Reduction of wires.
2. Reduction of drivers required in the computers.
3. Reduced load across the sensors.
4. Enhanced diagnostics.

The CCD system uses a twisted pair of wires to transmit the data in digital form. One of the wires is called the **bus (+)** and the other is **bus (-)**. Negative voltages are not used. The (+) and (-) indicate that one wire is more positive than the other when the bus is sending the dominant bit "0." All modules that are connected to the CCD bus system have a special CCD chip installed (Figure 11-4). In most vehicles (but not all), the body control module (BCM) will provide the bias voltage to power the bus circuits. Since the BCM powers the system, its internal components are illustrated (Figure 11-5). The other modules will operate the same as the BCM to send messages.

The bias voltage on the bus (+) and bus (-) circuits is approximately 2.50 volts when the system is idle (no data transmission occurring). This is accomplished through a regulated 5-volt circuit and a series of resistors. The regulated 5 volts sends current through a 13K-ohm resistor to the bus (-) circuit (Figure 11-6). The current is then sent through the two 120-ohm resistors that are wired in parallel and to the bus (+) circuit. Finally, the current is sent to ground through a second 13K-ohm resistor. A simplified schematic of this biasing circuit is shown along with the normal voltage drops that occur as a result of the resistors (Figure 11-7). The two 120-ohm resistors are referred to as **termination resistors**. Termination resistors are used to control induced voltages. Since voltage is dropped over resistors, the induced

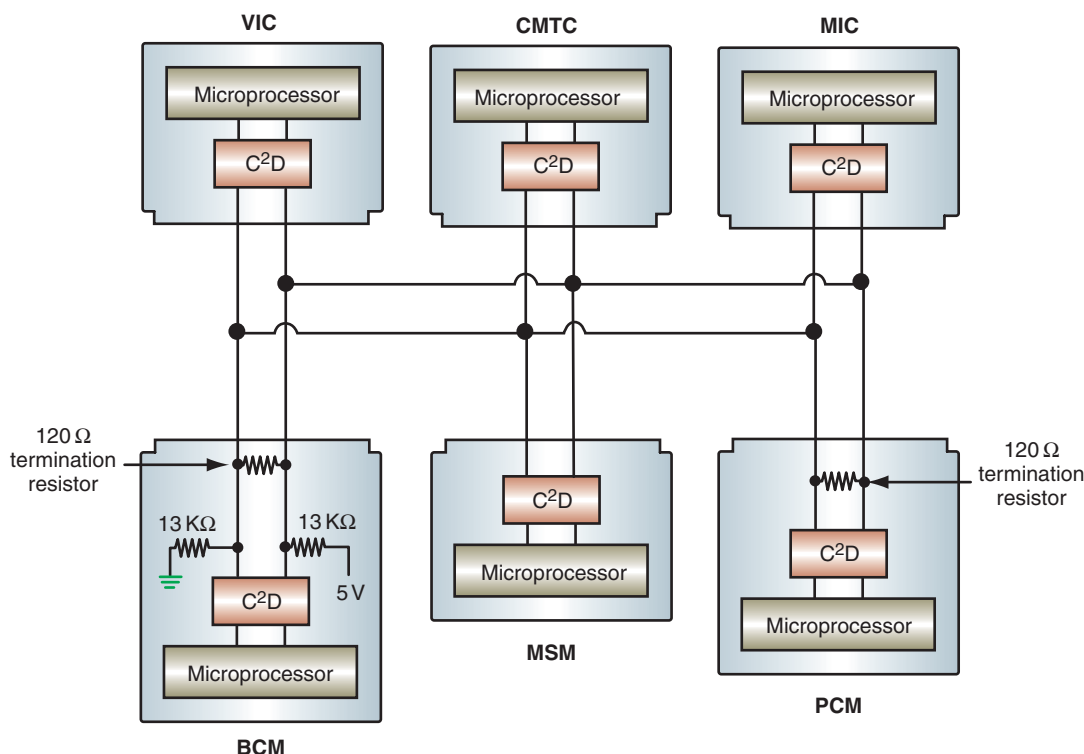


FIGURE 11-4 Each module on the CCD bus system has a CCD (C<sup>2</sup>D) chip.

The Chrysler Collision Detection (CCD) system is also referred to as C2D (C squared D).



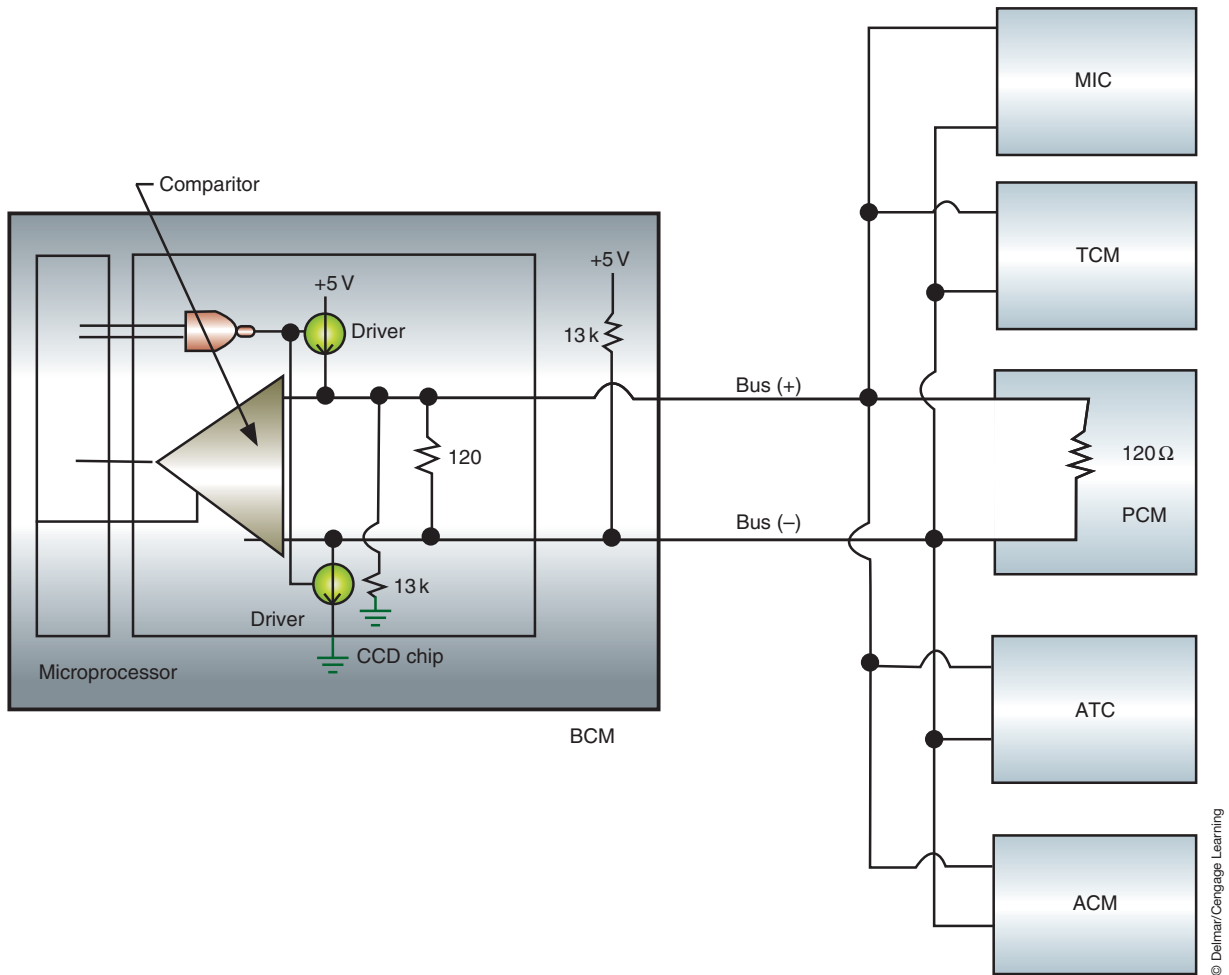


FIGURE 11-5 CCD bus circuit.

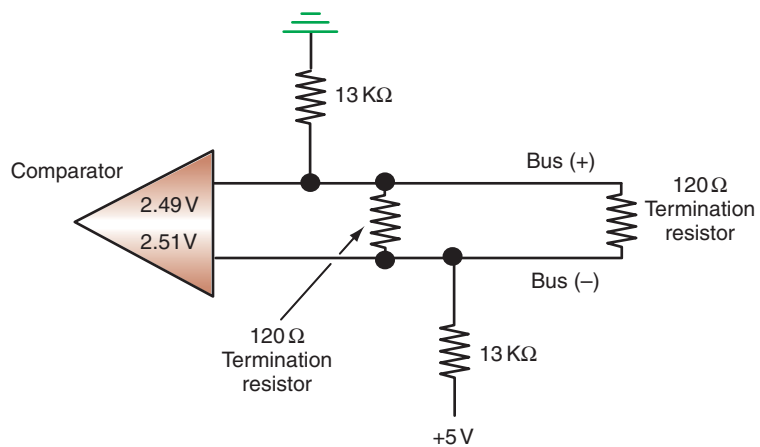


FIGURE 11-6 The bus is supplied 2.5 volts through the use of pull-up and pull-down resistors.

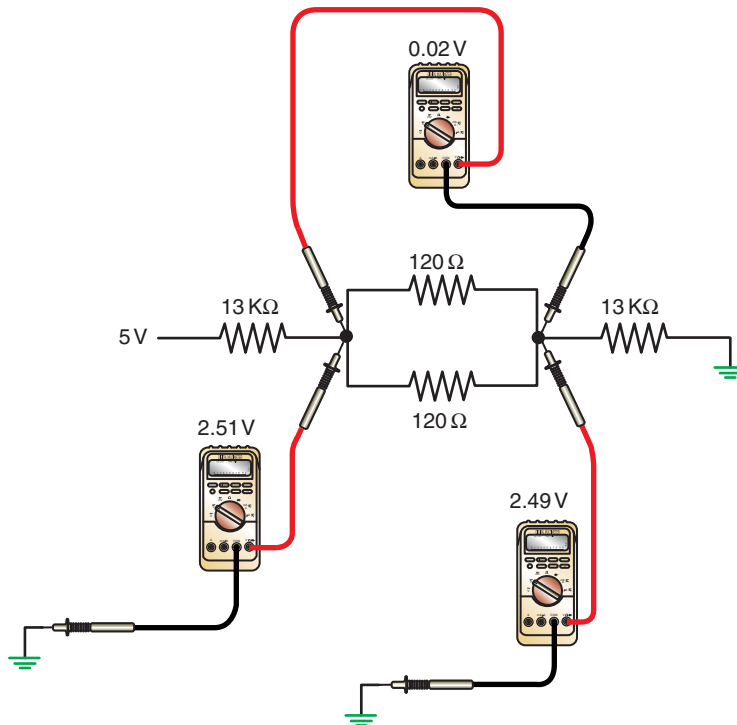


FIGURE 11-7 Simplified bus bias circuit for clarification.

© Delmar/Cengage Learning

voltage is terminated. One termination resistor is internal to the BCM while the other is located in the powertrain control module (PCM).

With the bus circuits at the proper voltage levels, communication can occur. The comparator in the CCD chip acts as a voltmeter. If the positive lead of the voltmeter is connected to the bus (+) circuit and the negative lead is connected to the bus (-) circuit, the voltmeter will read the voltage difference between the circuits. At idle, the difference is 0.02 volts. When a module needs to send a message, the microprocessor will use the NAND gate to turn on and off the two drivers at the same time (Figure 11-8). The driver to the bus (+) circuit provides alternate 5 volts to the bus (+) circuit. The comparator will measure this voltage. At the

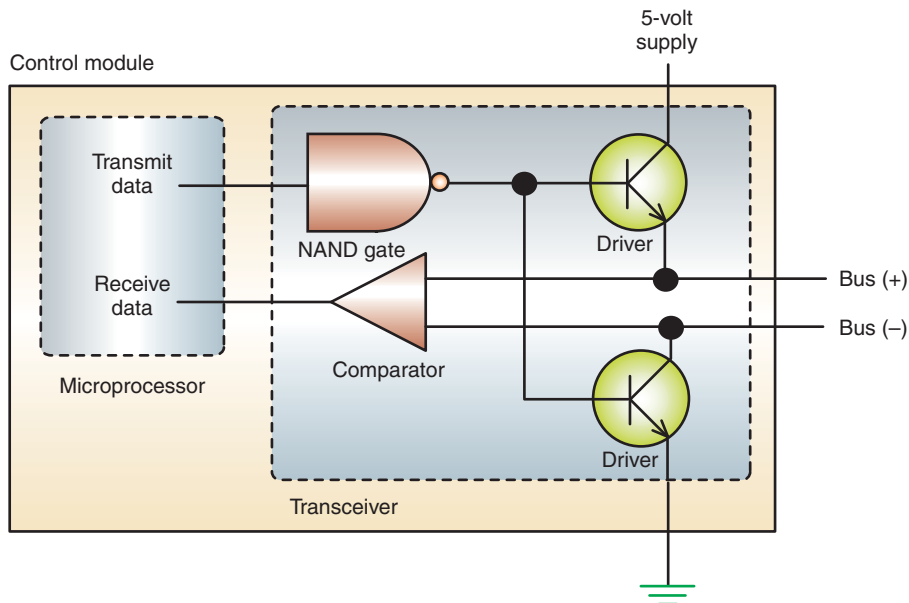
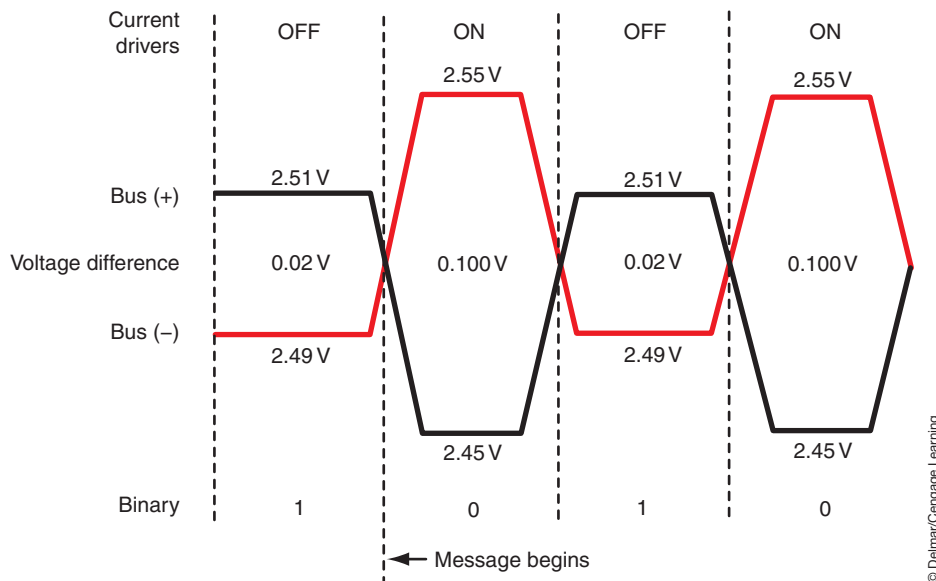


FIGURE 11-8 For a message to be transmitted, the drivers are activated, which pulls up bias on bus (+) and pulls down bias on bus (-).

© Delmar/Cengage Learning



**FIGURE 11-9** As the drivers are activated, the voltage difference between bus (+) and bus (-) increases over their voltage values at idle. The difference in voltage determines if a binary 1 or 0 is being transmitted.

same time, the driver to the bus (-) circuit provides an alternate ground path for the original 5 volts. This alternate ground bypasses the termination resistors and the second 13K-ohm resistor. Since the first 13K-ohm resistor is now the only one in the circuit, all of the voltage is dropped over it and the comparator will see low voltage on the bus (-) circuit.

Since the drivers are turned on and off at a rate of 7812.5 times per second, the voltage will not go to a full 5 volts on bus (+) nor to 0 volts on bus (-). However, bus (+) voltage is pulled higher *toward* 5 volts and bus (-) is pulled lower *toward* 0 volts (Figure 11-9). Once the comparator measures a voltage difference greater than 0.060 volts, the computers will recognize a bit value change. When the bus circuit is idle (0.02 voltage difference), the bit value is a 1. Once the voltage difference increases, the bit value is changed to a 0.

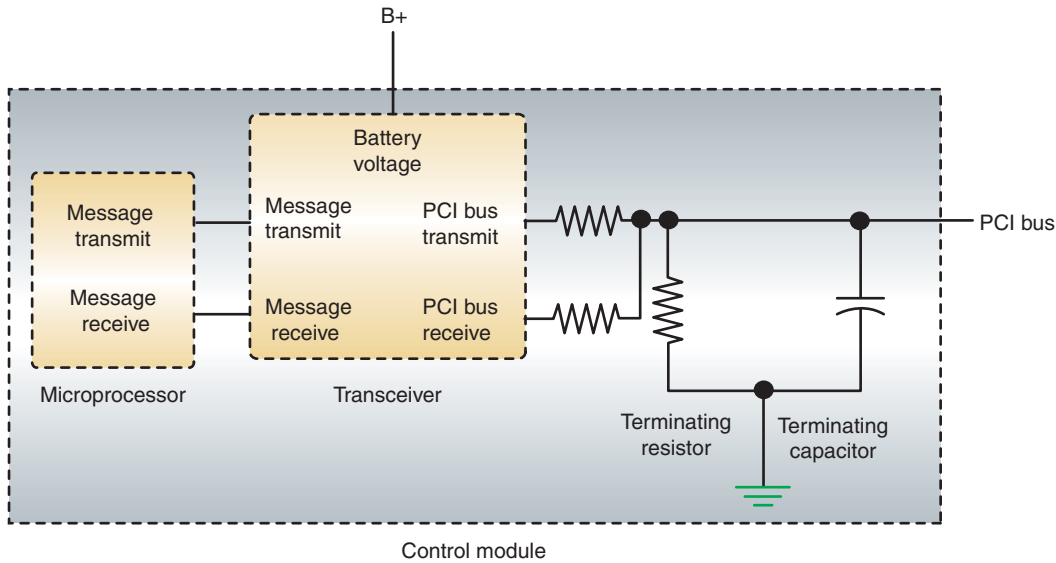
## Class B Data Bus Network

The J1850 protocol regulates the class B data bus network. As an example of this system, we will look at a VPW 10.4 Kb/s system that Chrysler uses. This system is similar to General Motors, class 2 bus.

Beginning in the 1998 model year, Chrysler began to phase out the CCD bus system and replace it with a new **Programmable Communication Interface (PCI)** bus system. Since this system is similar to that of other manufacturers, it will be used for discussion purposes.

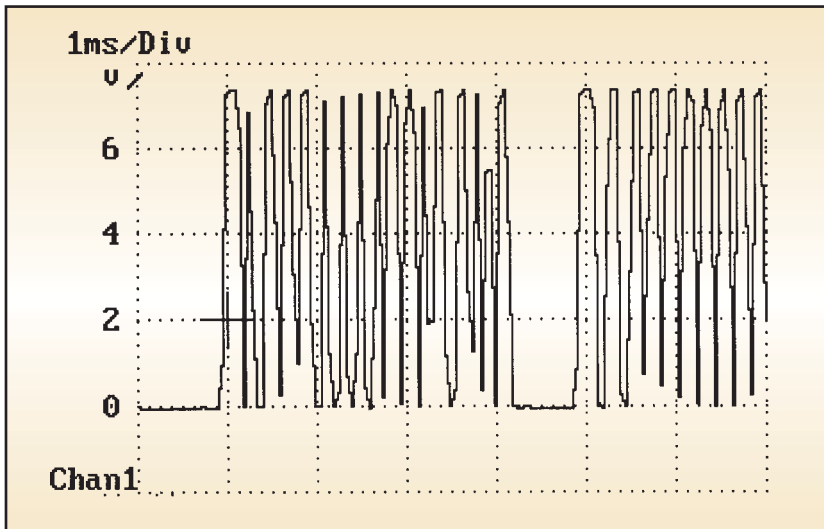
The PCI system is a single-wire, bidirectional communication bus. Each module on the bus system supplies its own bias voltage and has its own termination resistors (Figure 11-10). Like the CCD system, the modules of the PCI system are connected in parallel. As a message is sent, a variable pulse-width modulation (VPWM) voltage between 0 and 7.75 volts is used to represent the 1 and 0 bits (Figure 11-11). The voltage signal is not a clean digital signal. Rather, the voltage traces appear to be trapezoidal in shape because the voltage is slowly ramped up and down to prevent magnetic induction.

**AUTHOR'S NOTE:** The reference to “slowly ramped up and down” is relative. In the PCI bus, an average of 10,400 bits are transmitted per second. So, relatively speaking, the voltage is slow to go to 7.75 volts and slow to return to 0 volts.



**FIGURE 11-10** Bias and termination is supplied by each module on the PCI bus system.

© Delmar/Cengage Learning



**FIGURE 11-11** Lab scope trace of PCI bus voltages.

© Delmar/Cengage Learning

The length of time the voltage is high or low determines if the bit value is a 1 or a 0 (Figure 11-12). The typical PCI bus message will have the following elements (Figure 11-13):

- Header—One to three bytes of information concerning the type, length, priority, target module, and sending module.
- Data byte(s)—The message that is being sent. This can be up to 8 bytes in length.
- Cyclic Redundancy Check (CRC) byte—Detects if the message has been corrupted or if there are any other errors.
- In-Frame Response (IFR) byte(s)—If the sending module requires an acknowledgment or an immediate response from the target module, this request will be received with the message. The IFR is the target module sending the requested information to the original sending module.

Figure 11-14 illustrates the type of information that is sent over the PCI bus system.

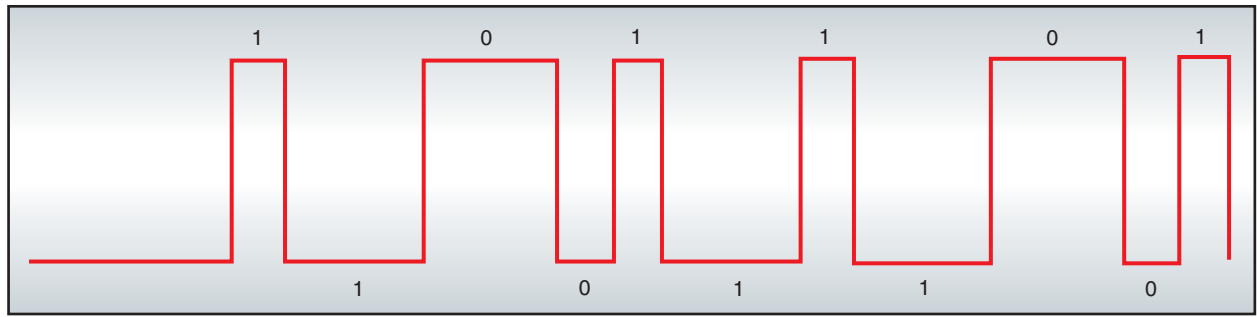


FIGURE 11-12 The VPWM determines the bit value.

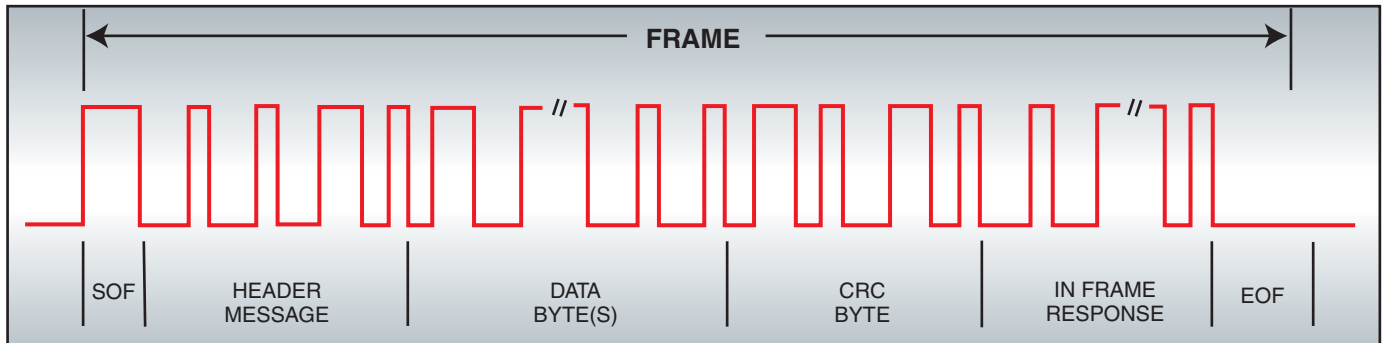


FIGURE 11-13 Components of a typical PCI bus message.

### Shop Manual

Chapter 11, page 457

## Controller Area Network

**AUTHOR'S NOTE:** The following is an example of the controller area network (CAN) bus system. Again, baud rates and design vary between manufacturers. This is provided as a common method used. By understanding this system, you should be able to grasp any system design.



### A BIT OF HISTORY

The first production car to use a CAN network was the 1991 Mercedes S-Class.

Most vehicles that are following the J2284 protocol integrate either two or three controller area network bus networks that operate at different baud rates. The lower-speed bus is typically used for vehicle body functions such as seat, window, radio, and instrumentation. A high-speed bus is used for real-time functions such as required for engine management and antilock brake operation. The third CAN bus would be used for diagnostics.

The CAN bus system uses terminology such as CAN B and CAN C. The letters *B* and *C* distinguish the speed of the bus. CAN B is a medium-speed bus with a speed of up to 125,000 bits per second. The CAN C bus has a speed of 500,000 bits per second. A vehicle can be equipped with both of these bus networks. In addition, a new diagnostics CAN C bus is used to connect the scan tool. Diagnostic CAN C (which can be called by many different names) has a speed of 500,000 bits per second.

The CAN bus circuit consists of a pair of twisted wires. The transfer of digital data is done by simultaneously pulling the voltage on one circuit high, and pulling the voltage on the other circuit low. The wires for the CAN bus system are twisted to reduce electromagnetic interference (EMI). This requires 33 to 50 twists per meter. To maintain the twist, the bus wire pair is in adjacent cavities at connectors. Wires are routed to avoid parallel paths with high-current sources, such as ignition coil drivers, motors, and high-current PWM circuits.

**POWERTRAIN CONTROL MODULE**

Broadcasts	Receives
<ul style="list-style-type: none"> <li>* A/C pressure</li> <li>* Brake switch ON</li> <li>* Charging system malfunction</li> <li>* Engine coolant temperature</li> <li>* Engine size</li> <li>* Engine RPM</li> <li>* Fuel type</li> <li>* Injector ON time</li> <li>* Intake air temperature</li> <li>* Map sensor</li> <li>* MIL lamp ON</li> <li>* Target idle speed</li> <li>* Throttle position</li> <li>* Vehicle speed</li> <li>* VIN</li> </ul>	<ul style="list-style-type: none"> <li>* A/C request</li> <li>* Ambient temperature</li> <li>* Fuel level</li> <li>* VTSS message</li> <li>* Ignition OFF</li> <li>* Idle speed request</li> <li>* Transmission temperature</li> <li>* OBD II faults</li> </ul>

**BODY CONTROL MODULE**

Broadcasts	Receives
<ul style="list-style-type: none"> <li>* Ambient temperature</li> <li>* A/C request</li> <li>* ATC head status</li> <li>* Distance to empty</li> <li>* Fuel economy</li> <li>* Low fuel</li> <li>* Odometer</li> <li>* RKE key fob press</li> <li>* Seat belt switch</li> <li>* Switch status</li> <li>* Trip odometer</li> <li>* VTSS lamp status</li> <li>* VTSS status</li> </ul>	<ul style="list-style-type: none"> <li>* ATC request</li> <li>* A/C clutch status</li> <li>* Cluster type</li> <li>* Engine RPM</li> <li>* Engine sensor status</li> <li>* Engine size</li> <li>* Fuel type</li> <li>* Odometer info</li> <li>* Injector ON time</li> <li>* High beam</li> <li>* MAP</li> <li>* OTIS reset</li> <li>* PRND3L status</li> <li>* US/Metric toggle</li> <li>* VIN</li> </ul>

© Delmar/Cengage Learning

**MECHANICAL INSTRUMENT CLUSTER**

Broadcasts	Receives
<ul style="list-style-type: none"> <li>* Air-bag lamp</li> <li>* Chime request</li> <li>* High beam</li> <li>* Traction switch</li> </ul>	<ul style="list-style-type: none"> <li>* A/C faults</li> <li>* Air-bag lamp</li> <li>* Charging system status</li> <li>* Door status</li> <li>* Dimming message</li> <li>* Engine coolant temperature</li> <li>* Fuel gauge</li> <li>* Low fuel warning</li> <li>* MIL lamp</li> <li>* Odometer</li> <li>* PCM DTC info</li> <li>* PRND3L position</li> <li>* Speed control ON</li> <li>* Trip odometer</li> <li>* US/metric toggle</li> <li>* Vehicle speed</li> </ul>

**TRANSMISSION CONTROL MODULE**

Broadcasts	Receives
<ul style="list-style-type: none"> <li>* PRND3L position</li> <li>* TCM OBD II faults</li> <li>* Transmission temperature</li> </ul>	<ul style="list-style-type: none"> <li>* Ambient temperature</li> <li>* Brake ON</li> <li>* Engine coolant temperature</li> <li>* Engine size</li> <li>* MAP</li> <li>* Speed control ON</li> <li>* Target idle</li> <li>* Torque reduction confirmation</li> <li>* VIN</li> </ul>

**RADIO**

Receives
<ul style="list-style-type: none"> <li>* Display brightness</li> <li>* RKE ID</li> </ul>

**OVERHEAD CONSOLE**

Receives
<ul style="list-style-type: none"> <li>* Average fuel economy</li> <li>* Dimming message</li> <li>* Distance to empty</li> <li>* Elapsed time</li> <li>* Instant fuel economy</li> <li>* Outside temperature</li> <li>* Trip odometer</li> </ul>

**AIR BAG MODULE**

Broadcasts	Receives
<ul style="list-style-type: none"> <li>* Air-bag deployment</li> <li>* Air-bag lamp request</li> </ul>	<ul style="list-style-type: none"> <li>* Air-bag lamp status</li> </ul>

**ABS CONTROLLER**

Broadcasts	Receives
<ul style="list-style-type: none"> <li>* ABS status</li> <li>* Yellow light status</li> <li>* TRAC OFF</li> </ul>	<ul style="list-style-type: none"> <li>* ABS status</li> <li>* Yellow light status</li> <li>* TRAC OFF</li> <li>* Traction switch</li> </ul>

**DATA LINK CONNECTOR**

© Delmar/Cengage Learning

**FIGURE 11-14** Chart of messages received and broadcasted by each module on the PCI bus.



On a CAN bus system, each module provides its own bias. Because of this, communication between groups of modules is still possible if an open occurs in the bus circuit. The CAN bus transceiver has drivers internal to the transceiver chip to supply the voltage and ground to the bus circuit.

Each CAN bus system has its advantages and limitations. For example, the high-speed CAN C bus may be functional only when the ignition is on. On the other hand, the CAN B bus can remain active when the ignition is turned off, if a module requires it to be active. The requirements of each module determine which bus system it will be connected to. The use of two separate bus networks on the same vehicle gives the manufacturer the optimum characteristics of each system.

**AUTHOR'S NOTE: Some CAN C bus networks do become active based on an event on the CAN B bus. Also, if the CAN C bus is used for vehicle interior systems it is event driven.**

Vehicle systems that exchange data at real time use CAN C. Typically these modules would be the antilock brake module and the powertrain control module. The manufacturer may also include the transmission control module and other modules that require real-time information. Other modules that may need to transfer data with the ignition turned off will be connected to the CAN B bus.

Most CAN B bus systems are very fault tolerant and can operate with one of their conductors shorted to ground or both of their conductors shorted together. Provided there is an electrical potential between one of the CAN B circuits and chassis ground, communication may still be possible. Due to its high speed, CAN C is not fault tolerant.

**YOU SHOULD KNOW: Since the CAN B bus can be designed to have a baud rate between 10.4 Kb/s and 125 Kb/s, fault tolerance diminishes as the baud rate increases.**

When CAN C bus becomes active the bus is biased to approximately 2.5 volts. When both CAN C (+) and CAN C (-) are equal, the bus is recessive and the bit "1" is transmitted. When CAN C (+) is pulled high and CAN C (-) is pulled low, the bit "0" is transmitted. When the bit "0" is transmitted, the bus is considered dominant (Figure 11-15). To be dominant, the voltage difference between CAN C (+) and CAN C (-) must be at least 1.5 volts and not more than 3.0 volts. To be recessive, the voltage difference between the two circuits must not be more than 50 mV.

The optimum CAN C bus termination is 60 ohms. Two CAN C modules will provide 120 ohms of termination each. Since the modules are wired in parallel, total resistance is 60 ohms. The two modules that provide termination are typically located the farthest apart from each other. The terminating modules have two 60-ohm resistors that are connected in series to equal the 120 ohms. Common to both resistors are the connections to the center tap and ultimately through a capacitor to ground. This center tap may also be connected to the transceiver (Figure 11-16). The other ends of the resistors are connected to CAN (+) and to CAN (-).

**AUTHOR'S NOTE: Some CAN bus networks will have additional termination resistance in other modules. Due to this, the total resistance of the bus may be lower than 60 ohms.**

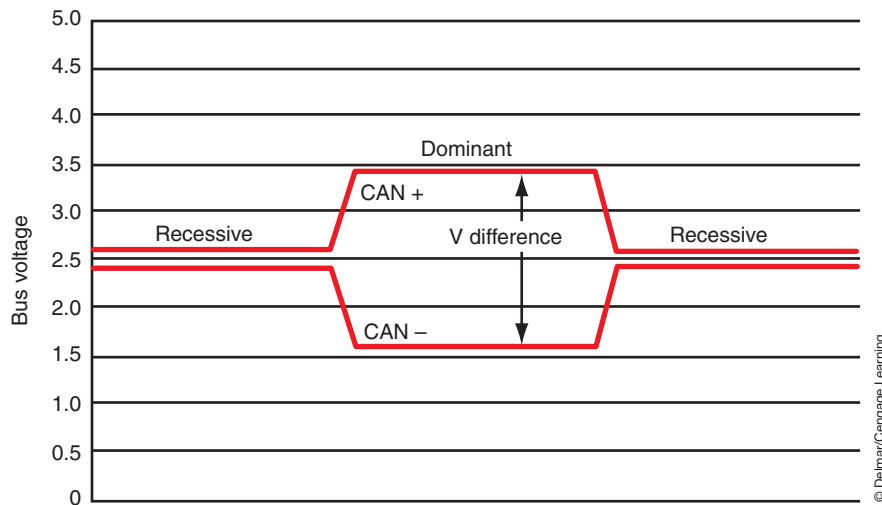


FIGURE 11-15 Voltages on the CAN C bus.

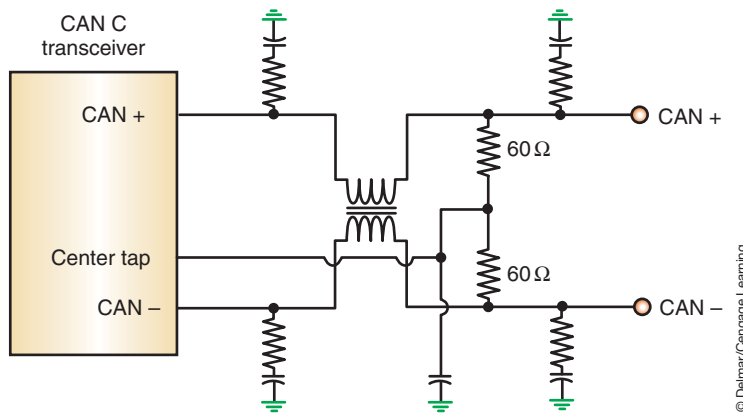


FIGURE 11-16 Termination resistance of a CAN C module.

The CAN B bus can be active whether the ignition is on or off. When CAN B (+) is approximately 0 to 0.2 volts and CAN B (-) is 4.8 to 5 volts, the bus is idle or recessive. In this state, the logic is “1.” When CAN B (+) is pulled between 3.6 and 5 volts and CAN B (-) is pulled low to 1.4 to 0 volts, the bus is considered dominant and the logic is “0” (Figure 11-17). When CAN B (+) is approximately 0 volts and CAN B (-) is near battery voltage, the bus is asleep.

Each module on the CAN B bus supplies its own termination resistance. Total bus termination resistance is determined by the number of modules installed on the vehicle. Internal to CAN B modules are two termination resistors. The resistors connect CAN B (+) and CAN B (-) to their respective transceiver termination pins (Figure 11-18). To provide termination and bias, the transceiver internally connects the CAN B (+) resistor to ground and the CAN B (-) resistor to a 5-volt source. When the CAN B bus goes into sleep mode, the termination pin connected to CAN B (-) switches from 5 volts to battery voltage by the transceiver.

Some of the network messages are defined by the following:

- **Cyclic:** A message launched on a periodic schedule. An example is the ignition on status broadcasts on the CAN B bus every 100 ms.
- **Spontaneous:** An application-driven message.
- **Cyclic and Change:** A message launched on a periodic schedule as long as the signal D is not changing. The message is relaunched whenever the signal changes.
- **By Active Function (BAF):** A message that is only transmitted at a specific rate when the message does not equal a default value.

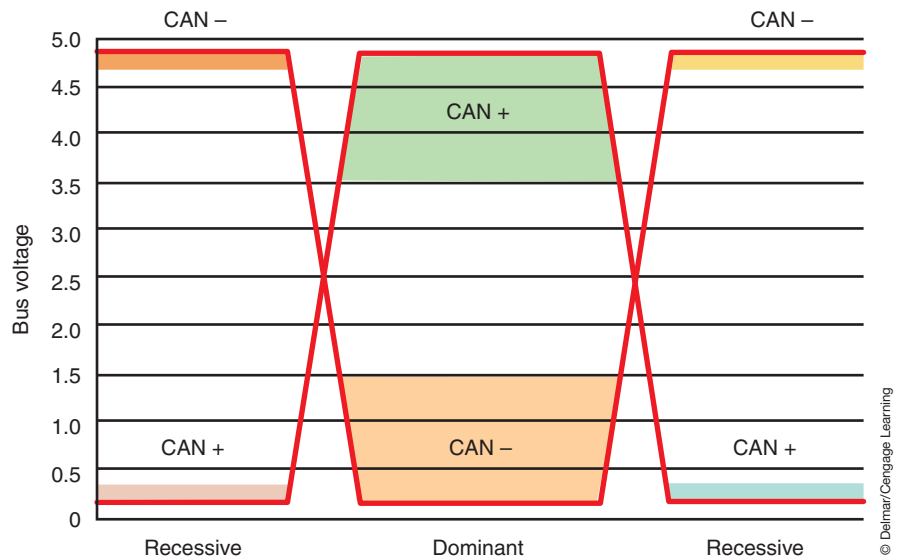


FIGURE 11-17 Typical CAN B bus voltages.

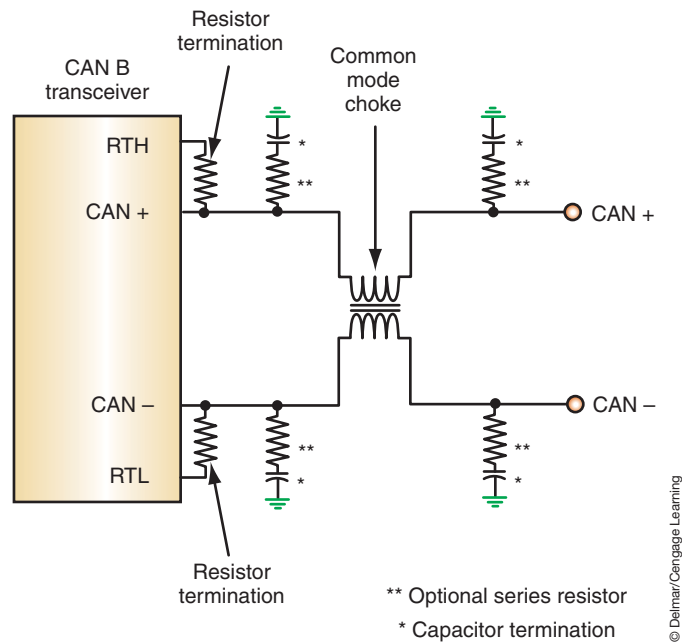


FIGURE 11-18 CAN B bus module termination resistance.

A **central gateway (CGW)** module is used where all three CAN bus networks (CAN B, CAN C, and diagnostic CAN C) connect together. Similar to a router in a computer network, this module allows data exchange between the different busses. The CGW can take a message on one bus and transfer that message to the other bus without changing the message. If several messages are being sent simultaneously, some of the messages will be captured in a buffer and sent out based on priority. The CGW also monitors the CAN network for failures and can log a network DTC (U code) if it detects a malfunction.

The CGW is also the gateway to the CAN network for the scan tool. The scan tool is connected to the gateway using its own CAN bus circuit known as diagnostic CAN C. Because CAN C is used for diagnostics, data can be exchanged with the scan tool at a real-time rate (500 Kb/s). As a result, a scan tool that is compatible with the CAN bus system is required for vehicle diagnosis.

Since a variety of generic scan tools may be connected to the vehicle, mandated regulations prohibit scan tools from containing any termination resistance. Due to the speed of the CAN C bus, termination resistors that are used need to be closely matched. If termination resistance resided in the tool, the variance in the tool termination could affect the operation of the diagnostic CAN C bus. For this reason, the entire termination for the diagnostic CAN C resides in the CGW. The configuration of the resistors is similar to a dominant CAN C module except two 30-ohm resistors are connected in series.

**AUTHOR'S NOTE: The most aggressive company advancing CAN bus networking into the automobile design is Intel.**

## SUPPLEMENTAL DATA BUS NETWORKS

Since no one data bus can handle all of the requirements of computer-controlled operations on today's vehicles, **supplemental bus networks** are also used. These are bus networks that are on the vehicle in addition to the main bus network. For example, a vehicle may have the CAN bus network and supplemental bus network to handle specified requirements. This section discusses the common bus networks that may also be on the vehicle.

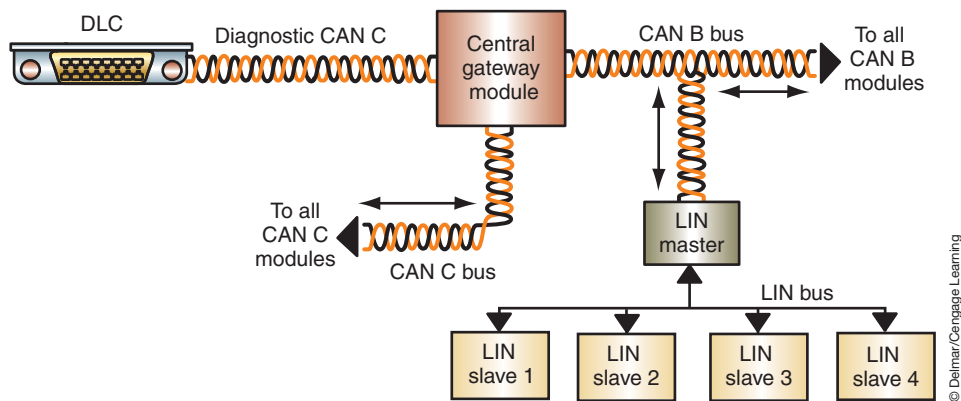
### Local Interconnect Network Data Bus

The **local interconnect network (LIN)** bus is a UART single master module, multiple slave module, low-speed network. The term *local interconnect* refers to all of the modules in the LIN network being located within a limited area. The LIN master module is connected to the CAN bus and controls the data transfer speed. The master module translates data between the slave module and the CAN bus (Figure 11-19). Diagnosis of the slave modules is performed through the master module. The termination resistance of the master module is 1K ohms.

The LIN bus system can support up to 15 slave modules. Slave modules use 30K-ohm termination resistors. The slave modules can be actual control modules or sensors and actuators. **Smart sensors** are capable of sending digital messages on the LIN bus. The intelligent actuators receive commands in digital signals on the LIN bus from the master module. Only one pin of the master module is required to monitor several sensors and actuators.

The data transmission is variable between 1 Kb/s and 20 Kb/s over a single wire. The specific baud rate is programmed into each module. When a steady 12 volts is applied to the circuit, there is no message and the recessive bit is sent (bit 1). To transmit a dominant bit (bit "0"), the circuit is pulled low by a transceiver in the module that is transmitting the message (Figure 11-20). The master module or the slave module can send messages.

**Shop Manual**  
Chapter 11, page 460



**FIGURE 11-19** The LIN master communicates messages from the slaves onto the CAN bus.

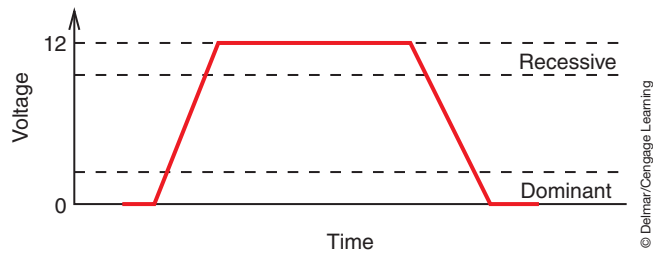


FIGURE 11-20 Voltages of the LIN bus.

## Media Oriented System Transport Data Bus

The **Media Oriented System Transport (MOST)** cooperation data bus system is based on standards established by cooperative efforts between automobile manufacturers, suppliers, and software programmers. The result is a data system that is specifically designed for the transmission of audio and video data. The MOST bus uses **fiber optics** to transmit data at a speed of upto 25 megabits per second (25 Mb/s). The fiber optics use light waves to transmit the data without the effects of EMI or RFI. In the past, video and audio were transmitted as analog signals. With the MOST system using a fiber optics data bus, the data communications is digital.

Modules on the MOST data bus use an LED, photodiode, and a MOST transceiver to communicate with light signals (Figure 11-21). The LED and photodiode are part of the fiber optic transceiver. The photodiode changes light signals into voltage that is then transmitted to the MOST transceiver. The LED is used to convert voltage signals from the MOST transceiver into light signals.

The conversion of light to voltage signals in the photodiode is by subjecting the P-N junction of the photodiode with light. When the junction is penetrated with light, the energy is converted to free electrons and holes. The electrons and holes pass through the junction in direct proportion to the amount of light. The photodiode is connected in series with a resistor (Figure 11-22). As the voltage through the photodiode increases, the voltage drop across the

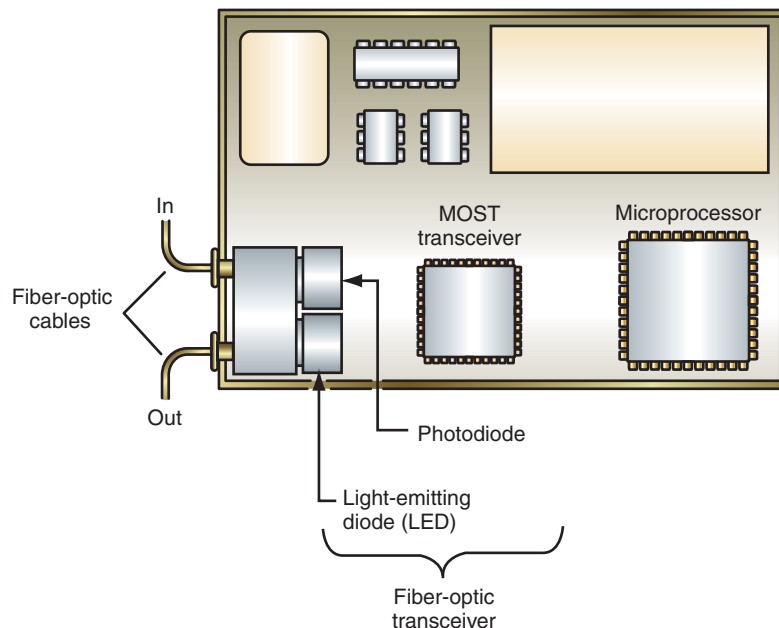
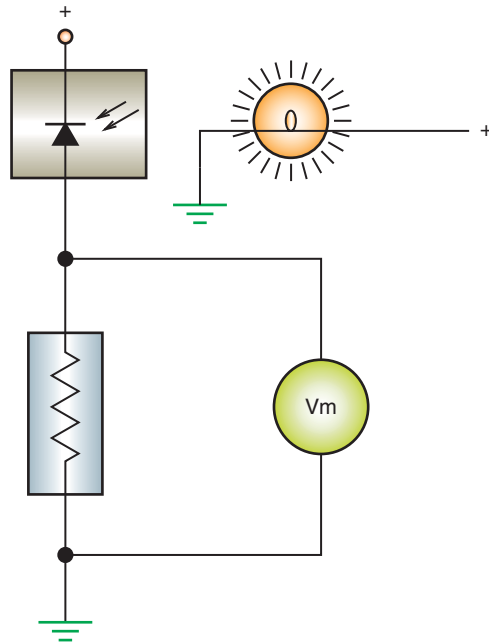


FIGURE 11-21 Typical MOST data system controller components.



**FIGURE 11-22** The voltage drop over the resistor changes in relation to the amount of light applied to the photodiode.

© Delmar/Cengage Learning

resistor also increases. Since the voltage drop changes with light intensity, the light signals are changed to voltage signals.

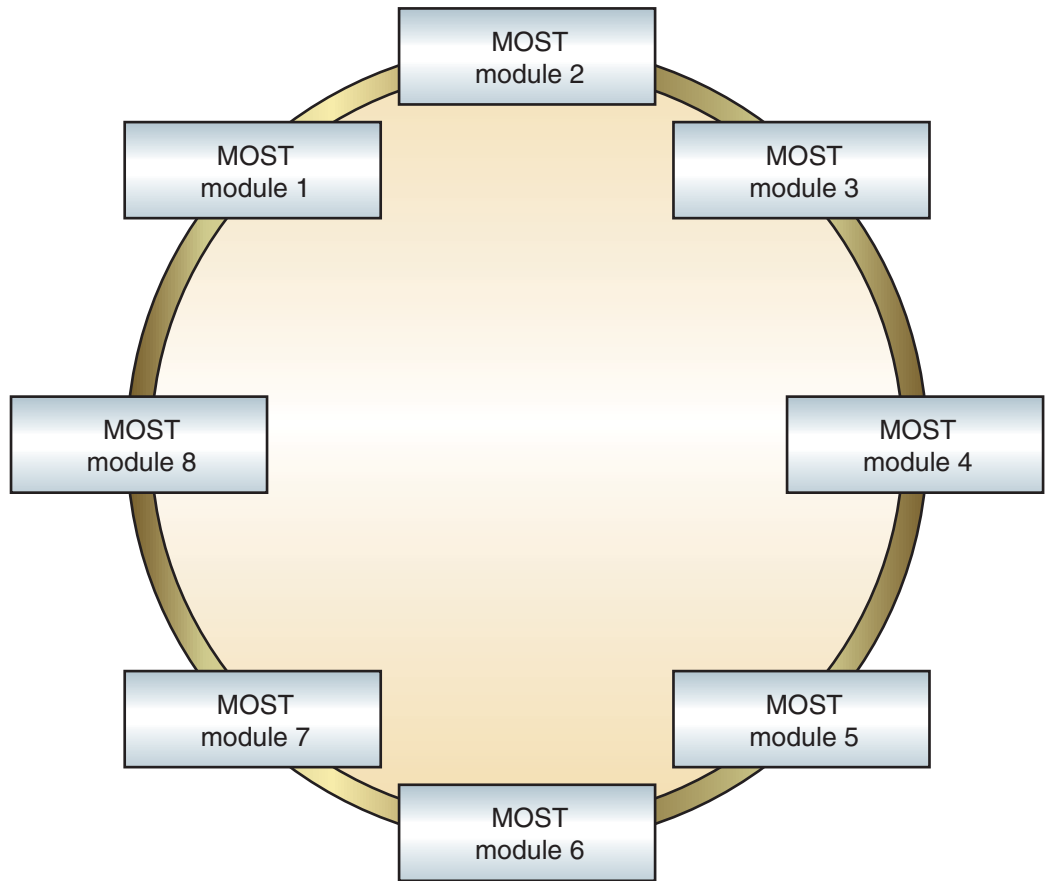
The microprocessor commands the MOST transceiver to send messages to the fiber optic transceiver as voltage signals. Also, the MOST transceiver sends voltage signals from the fiber optic transceiver to the microprocessor.

The modules are connected in a ring fashion by fiber-optic cable (Figure 11-23). Messages are sent in one direction only. The message is usually started by the master module, but not always. The master module sends the message onto the data bus with a duty cycle frequency of 44.1 kHz. This frequency corresponds to the frequency of digital audio and video equipment. A message that is originated by a module is sent to the next module in the ring. That module then sends it to the next module, and this continues until the originating module receives its own message. At this time the ring is closed and the message is no longer passed on. If a module receives a message that it does not need, the message is sent through the MOST transceiver and back to the fiber-optic transceiver without being transmitted to the microprocessor. If the MOST bus is powered down (asleep), it can be awakened by the ignition switch input or an input from a module. When an input is received, the master module will send a “wake up” message to all of the modules in the ring.

The fiber-optic cable is constructed with several layers (Figure 11-24). The core consists of polymethyl methacrylate (PMMA). Light travels through the core of the cable based on the principle of **total reflection**. Total reflection is achieved when a light wave strikes a layer that is between a dense and a thin material. The core of the cable is coated with an optically transparent reflective coating. The core makes up the dense material, and the coating is the thin material. The casing of the cable is made from polyamide and protects the core from outside light. An outer cover is colored so the cable can easily be identified, but it also protects the cable from damage and high temperatures.

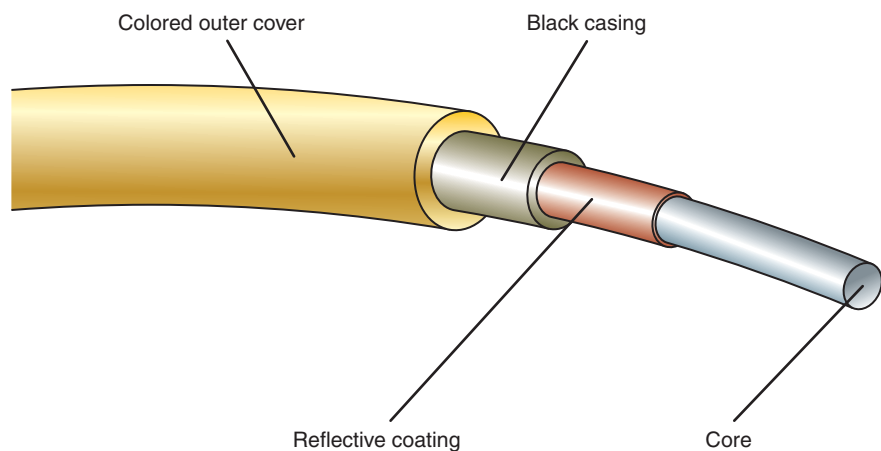
If the cable is laid out straight, some of the light travel through the core will be in a straight line. However, most of the light waves travel in a zigzag pattern (Figure 11-25). The zigzag pattern is a result of the total reflection. If the fiber-optic cable is bent, the light waves are reflected by total reflection at the borderline of the core coating and are guided through the bend (Figure 11-26).





**FIGURE 11-23** The MOST data system transfers data in a single direction through the use a ring configuration.

© Delmar/Cengage Learning

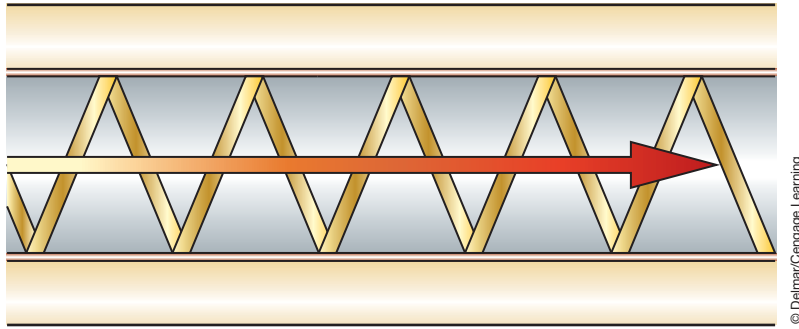


**FIGURE 11-24** Fiber optic cable construction.

© Delmar/Cengage Learning

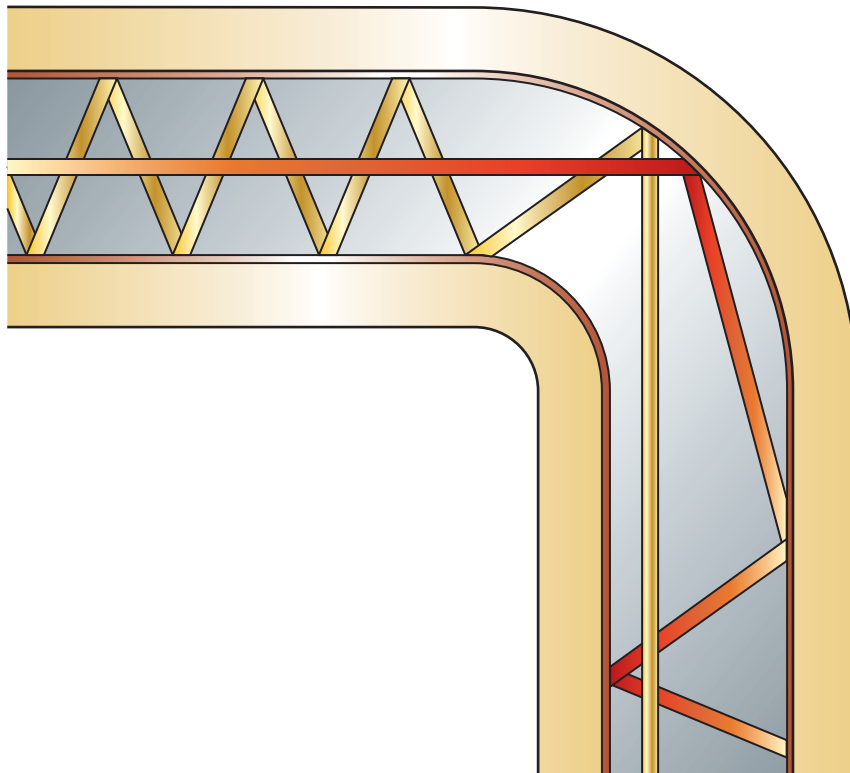
## Wireless Bus Networks

**Wireless networks** can connect modules together to transmit information without the use of physical connections by wires. For example, tire pressure information can be transmitted from a sensor in the tire to a module on the vehicle without wires. Although there are different technologies used for wireless communications, a popular one is called **Bluetooth**. Bluetooth technology allows several modules from different manufacturers to



**FIGURE 11-25** Light waves traveling through a straight section of the fiber optic cable.

© Delmar/Cengage Learning



**FIGURE 11-26** Light waves traveling through a curve in the fiber optic cable.

© Delmar/Cengage Learning



## A BIT OF HISTORY

The Bluetooth Special Interest Group consists of more than 2,000 companies. The name *Bluetooth* comes from the Viking King Harald Blåtand who was nicknamed Bluetooth. King Harald ruled Denmark between 940 and 985 AD. During his reign King Harald united Denmark and Norway. The name *Bluetooth* was adopted for a particular wireless communications technology because it shares the same philosophy as the king, multinational unity. Bluetooth unifies multinational companies. Bluetooth was initially a code name for the project; however, it has now become the trademark name.

be connected using a standardized radio transmission. Laptop computers, notepads, and hands-free cell phones are all examples of devices that may be connected in the vehicle through Bluetooth.

Radio transmission uses the 2.40 GHz to 2.48 GHz frequency range. Transmitting on this band does not require a license or a fee. The transmission rate is up to 1 Mb/s, and the normal operating range for transmissions is about 33 feet (10 meters). The short transmitting range makes it possible to integrate the antenna, control, encryption, and transmission/receiver technology into a single module.

Since the frequency range Bluetooth uses is the same as that of other wireless devices such as garage door openers, microwaves, and many types of medical equipment, the technology uses special measures to protect against interference. These measures include:

- Dividing the data into short message packages using a duration of about 625 ms.
- Using a check sum of 16 bits to confirm the messages were not corrupted.
- Automatically repeating the transmission of faulty data.
- Using language coding that is converted into digital signals.
- Changing the transmitting/receiving frequencies at random, 1600 times per second.

For security, the data is encrypted using a key that is 128 bits long. The receiver is checked for authenticity with the key. In addition, a secret password is used so devices can connect to each other. The key uses rolling code and is different for each connection.

To connect devices, each device is first adapted through the use of a personal identification number (PIN). When the PIN is entered, **piconets** are formed. These are small transmission cells that assist in the organization of the data. Each piconet will allow for up to eight devices to be operated at the same time. One device in each piconet will be assigned as the master. The master is responsible for establishing the connection and synchronizing the other devices. Once the PIN is entered, two Bluetooth-compatible devices will automatically establish a connection.

**AUTHOR'S NOTE: Each device has an address that is 48 bits long and is unique worldwide. This means over 281 trillion devices can be identified worldwide.**

## SUMMARY

- Multiplexing (MUX) is a system in which electrical signals are transmitted by a peripheral serial bus instead of by conventional wires. This allows several devices to share signals on a common conductor.
- A MUX wiring system uses bus data links that connect each module and allow for the transporting of data from one module to another.
- Each computer connected to the data bus is called a node.
- The Society of Automotive Engineers (SAE) has defined different classes of protocols according to their baud rate (speed of communication).
- ISO 9141-2 is not a network protocol since it can be used only for diagnostic purposes. It is a Class B system that has a baud rate of 10.4 Kb/s.
- An adoption of the ISO 9141-2 protocol is the ISO-K bus that allows for bidirectional communication on a single wire.
- The ISO 14230-4 protocol uses a single-wire, bidirectional data line to communicate between the scan tool and the nodes.
- J1850 protocol is the class B standard for OBD II. The J1850 standard allows for two different versions based on baud rate.
- The controller area network (CAN) system can support baud rates up to 1 Mb/s and is designed for real-time control of specific systems.
- One of the earliest multiplexing systems was developed by Chrysler in 1988 and used through the 2003 model year. This system is called Chrysler Collision Detection (CCD).
- The CCD system uses a twisted pair of wires to transmit the data in digital form. One of the wires is called the bus (+) and the other is bus (-).
- The CCD bias voltage on the bus (+) and bus (-) circuits is approximately 2.50 volts when the system is idle (no data transmission occurring). This is accomplished through a regulated 5-volt circuit and a series of resistors.
- The Programmable Communication Interface (PCI) system is a single-wire, bidirectional communication bus. Each module on the bus system supplies its own bias voltage and has its own termination resistors.
- The modules of the PCI system send messages by a variable pulse width modulation (VPWM) voltage; between 0 and 7.75 volts is used to represent the 1 and 0 bits.

## TERMS TO KNOW

Asynchronous

Baud rate

Bluetooth

Bus

Bus (-)

Bus (+)

Central gateway (CGW)

Chrysler Collision

Detection (CCD)

Controller Area

Network (CAN)

Fiber optics

ISO 9141-2

ISO 14230-4

ISO-K

J1850

## SUMMARY

---

- Most vehicles that are following the J2284 protocol integrate either two or three controller area network (CAN) bus networks that operate at different baud rates.
- The lower-speed bus is typically used for vehicle body functions such as seat, window, radio, and instrumentation control. A high-speed bus is used for real-time functions as required for engine management and antilock brake operation.
- The circuitry of the CAN bus usually consists of a pair of twisted wires. For digital data to transfer, voltage is simultaneously pulled high on one circuit and pulled low on the other.
- A central gateway (CGW) module is used where all three CAN bus networks (CAN B, CAN C, and diagnostic CAN C) connect together. Similar to a router in a computer network, this module allows data exchange between the different busses. The CGW is also the gateway to the CAN network for the scan tool.
- The local interconnect network (LIN) was developed to supplement the CAN bus system. The term *local interconnect* refers to all of the modules in the LIN network being located within a limited area.
- The LIN bus is a UART single master, multiple slave, low-speed network.
- The Media Oriented System Transport (MOST) cooperation data bus system is based on standards established by a cooperative effort between automobile manufacturers, suppliers, and software programmers that resulted in a data system specifically designed for the data transmission of media-oriented data. MOST uses fiber optics to transmit data at an extremely fast rate, up to 25 megabits per second.
- Modules on the MOST data bus use an LED, a photodiode, and a MOST transceiver to communicate with light signals.
- Wireless networks can connect modules together to transmit information without the use of physical connection by wires.
- Bluetooth technology allows several modules from different manufacturers to be connected using a standardized radio transmission.

## TERMS TO KNOW

(continued)

K-line  
L-line  
Local interconnect network (LIN)  
Master module  
Media Oriented System Transport (MOST)  
Multiplexing (MUX)  
Node  
Piconets  
Programmable Communication Interface (PCI)  
Protocol  
Slave modules  
Smart sensors  
Supplemental bus networks  
Termination resistors  
Total reflection  
Wireless networks

## REVIEW QUESTIONS

---

### Short-Answer Essay

1. Explain the principle of multiplexing.
2. Briefly describe the different multiplexing communication protocols.
3. Explain the different classes of communications.
4. Briefly explain the principle of operation of the CCD bus system as an example of Class A multiplexing.
5. Briefly explain the principle of operation of the PCI bus system as an example of Class B multiplexing.
6. Briefly explain the principle of operation of the Controller Area Network (CAN) bus system.
7. Describe the purpose and operation of different supplemental data bus networks.
8. Explain the operation of the local interconnect network data bus system.
9. Describe the operation of the Media Oriented System Transport data bus using fiber optics.
10. Explain the operation of wireless networks using Bluetooth technology.

### Fill in the Blanks

1. Multiplexing provides the ability to use a \_\_\_\_\_ circuit to distribute and share data between several control modules.
2. Each computer connected to the data bus is called a \_\_\_\_\_.
3. The \_\_\_\_\_ protocol is the class B standard for OBD II.
4. The CCD system uses a twisted pair of wires to transmit the data in \_\_\_\_\_ form.
5. \_\_\_\_\_ are used to control induced voltages.
6. The PCI system uses a \_\_\_\_\_ pulse width modulation voltage between 0 and 7.75 volts to represent the 1 and 0 bits.

7. A \_\_\_\_\_ module is used where all three CAN bus networks (CAN B, CAN C, and diagnostic CAN C) connect together.
8. In the MOST data bus system, the \_\_\_\_\_ changes light signals into voltage that is then transmitted to the MOST transceiver.
9. The modules of the MOST data bus system are connected in a \_\_\_\_\_ fashion by fiber optic cable.
10. \_\_\_\_\_ technology allows several modules from different manufacturers to be connected using a standardized radio transmission.

## MULTIPLE CHOICE

---

1. In the CAN bus system:
  - A. CAN B is high speed and not fault tolerant.
  - B. CAN C is fault tolerant.
  - C. Can C is low speed and used for many body control functions.
  - D. None of the above.
2. All of the following statements concerning multiplexing are true EXCEPT:
  - A. Hard wiring and vehicle weight are reduced.
  - B. A single computer controls all of the vehicle functions.
  - C. Enhanced diagnostics are possible.
  - D. Reduces driver requirements in the computer.
3. The purpose of the central gateway module in a CAN bus system is:
  - A. To provide a means for the modules on the different CAN bus networks to communicate with each other.
  - B. To provide a method for the scan tool to communicate with the modules.
  - C. Both A and B.
  - D. Neither A nor B.
4. *Technician A* says that some multiplexing systems use a data bus that consists of a twisted pair of wires.  
*Technician B* says that some multiplexing systems use a data bus that consists of a single wire.  
Who is correct?
  - A. A only.
  - B. B only.
  - C. Both A and B.
  - D. Neither A nor B.
5. On a data bus that uses two wires, why are the wires twisted?
  - A. To increase the physical strength of the wires.
  - B. For identification of the circuit.
  - C. To reduce the effect of the high current flow through the bus wires on other circuits.
  - D. To minimize the effects of an induced voltage on the data bus.
6. In the local interconnect network (LIN) bus:
  - A. The master controller is connected to the CAN bus and controls the data transfer speed.
  - B. The master controller translates data between the slave modules and the CAN bus.
  - C. Supporting up to 15 slave modules is possible.
  - D. All of the above.
7. Protocol is defined as:
  - A. A common communication method.
  - B. A method of reducing EMI.
  - C. Data transmission through a single circuit.
  - D. All of the above.
8. *Technician A* says that multiplexed circuits are used to communicate multiple messages over a single circuit.  
*Technician B* says that multiplexed circuits communicate by transmitting serial data.  
Who is correct?
  - A. A only.
  - B. B only.
  - C. Both A and B.
  - D. Neither A nor B.
9. In a single-wire bus network, EMI is controlled by:
  - A. Using a shielded wire.
  - B. Slowly ramping up and down the voltage levels.
  - C. Locating the wire outside of the normal wiring harness.
  - D. None of the above.
10. A computer that can communicate on a data bus is known as:
  - A. Node.
  - B. Byte.
  - C. Protocol.
  - D. Transceiver.

# Chapter 12

## ADVANCED LIGHTING CIRCUITS

### UPON COMPLETION AND REVIEW OF THIS CHAPTER, YOU SHOULD BE ABLE TO UNDERSTAND AND DESCRIBE:

- The operation of common computer-controlled concealed headlight systems.
- The function of the computer-controlled headlight system.
- The function of automatic headlight on/off and time delay features.
- The operation of most common types of automatic headlight dimming systems.
- The operation of the SmartBeam headlight system as an example of today's sophisticated headlight systems.
- The function of automatic headlight leveling systems.
- The operation of adaptive headlight systems.
- The purpose and function of daytime running lamps.
- The operation of adaptive brake light systems.
- The operation of common illuminated entry systems.
- The operation of common instrument panel dimming systems.
- The use and function of fiber optics.
- The purpose and operation of lamp outage indicators.

### INTRODUCTION

With the addition of solid-state circuitry in the automobile, manufacturers have been able to incorporate several different lighting circuits or modify the existing ones. Some of the refinements that were made to the lighting system include automatic headlight washers, automatic headlight dimming, automatic on/off with timed delay headlights, and illuminated entry systems. Some of these systems use sophisticated body computer-controlled circuitry and fiber optics.

Some manufacturers have included such basic circuits as turn signals into their body computer to provide for pulse width dimming in place of a flasher unit. The body computer can also be used to control instrument panel lighting based on inputs, including if the side marker lights are on or off. By using the body computer to control many of the lighting circuits, the amount of wiring has been reduced. In addition, the use of computer control has provided a means of self-diagnosis in some applications.

### COMPUTER-CONTROLLED CONCEALED HEADLIGHTS

The body control module (BCM) has been utilized by some manufacturers to operate the concealed headlight system. The BCM will receive inputs from the headlight and flash-to-pass switches (Figure 12-1). When the headlight switch is turned on, the BCM receives a signal that the headlights are being activated. To open the headlight doors, the BCM energizes the open door relay. The contacts of the open relay are closed and battery voltage is applied to the door motor. In this example, battery voltage to operate the door motor is supplied from

**Shop Manual**  
Chapter 12,  
page 487



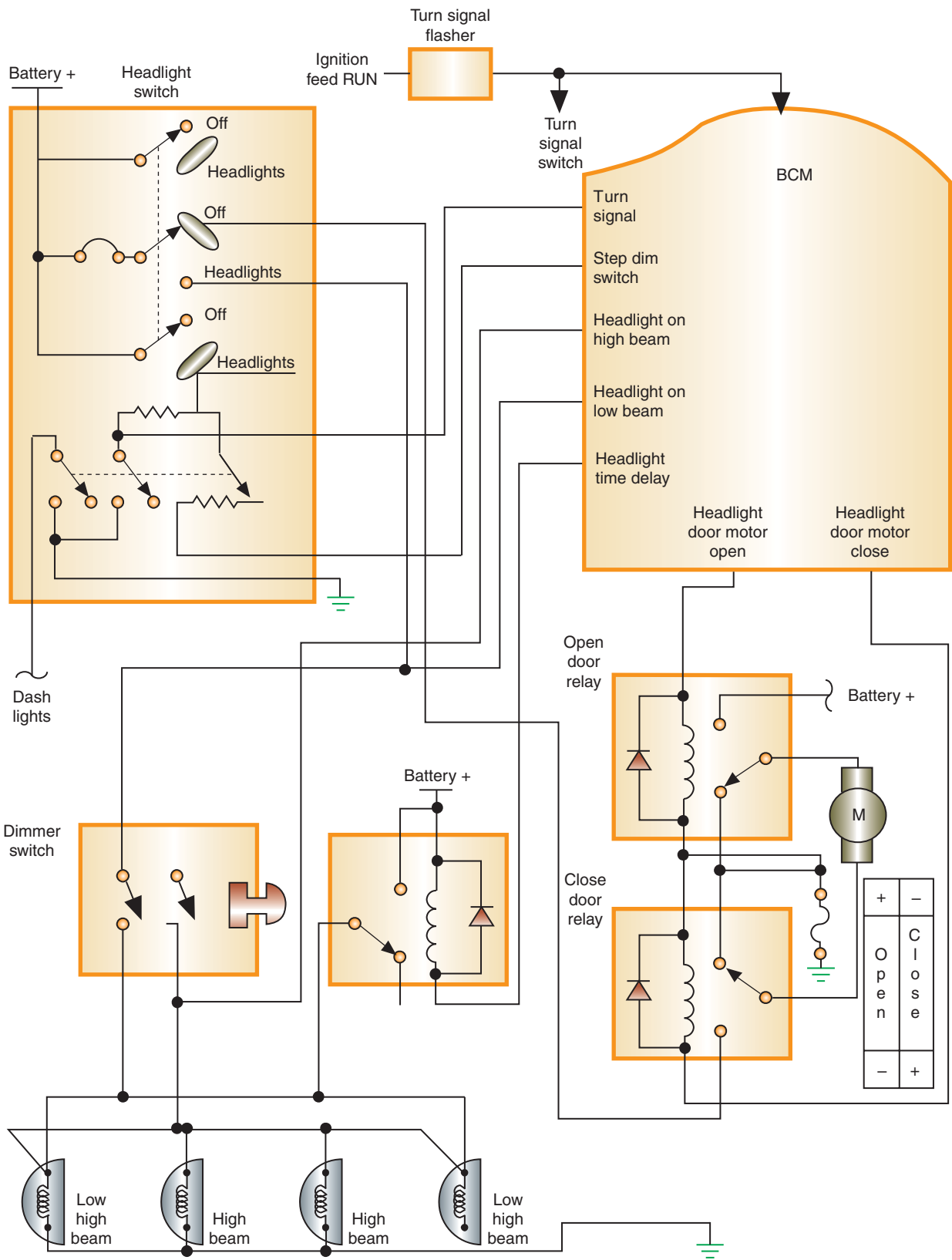


FIGURE 12-1 Computer-controlled concealed headlight door circuit.

the 30-ampere circuit breaker. The computer energizes the door open relay, which moves the normally open relay contact arm. Ground is provided through the door close relay contact.

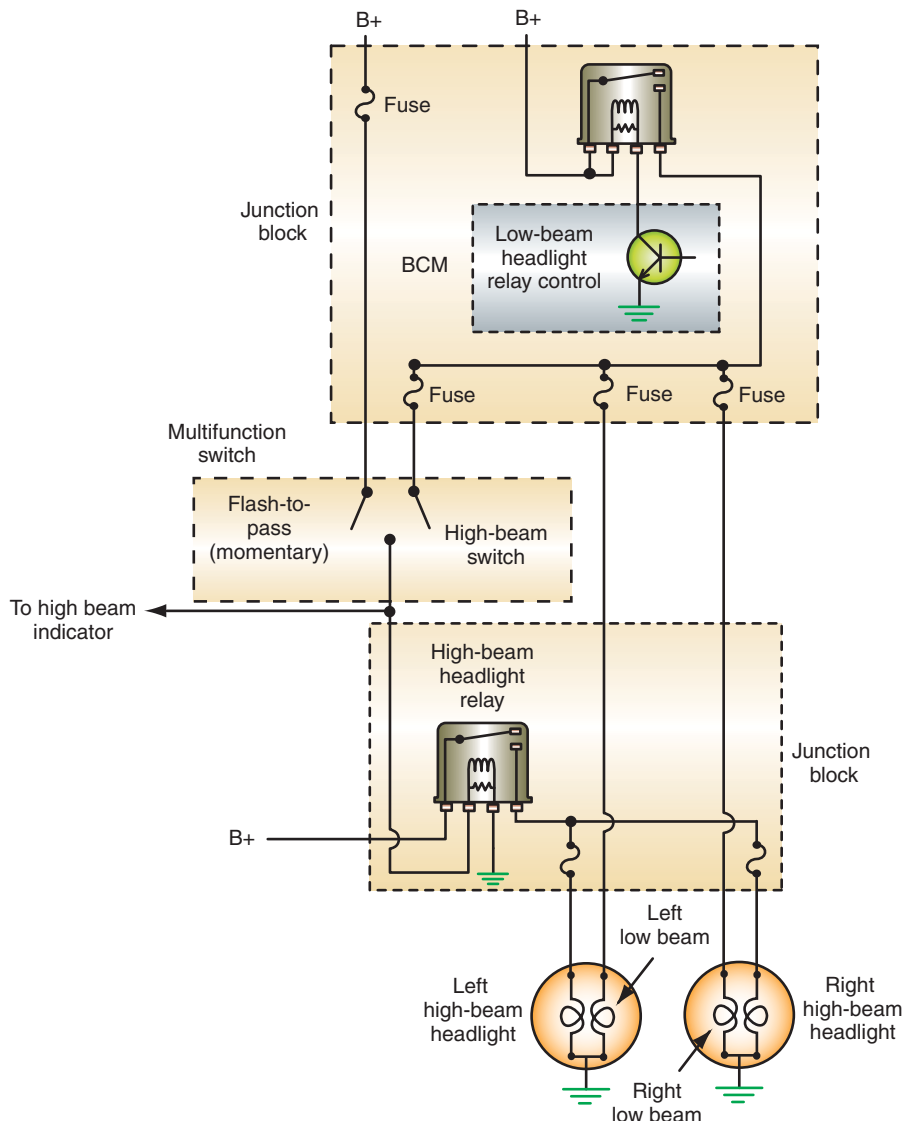
**AUTHOR'S NOTE:** Another module besides the BCM can be used to operate the concealed headlight system; however, the function of the system is the same as described.

## COMPUTER-CONTROLLED HEADLIGHT SYSTEMS

The computer can be used to control the operation of the headlights. Simpler circuits use the headlight switch as an input to the body computer. The headlight switch is usually a **resistive multiplex** switch that provides multiple inputs over a single circuit. The BCM sends a fixed voltage to the switch through a fixed resistor. Each switch position has a different resistor value in series with the fixed resistor. As different switch positions are selected, voltage drop over the fixed resistor changes.

The BCM will control the relays associated with the exterior lighting. If input from the switch indicates that the headlights are requested, the BCM will energize the low-beam headlight relay (Figure 12-2). With this relay energized, current flows to the low-beam lamps.

**Shop Manual**  
Chapter 12,  
page 489



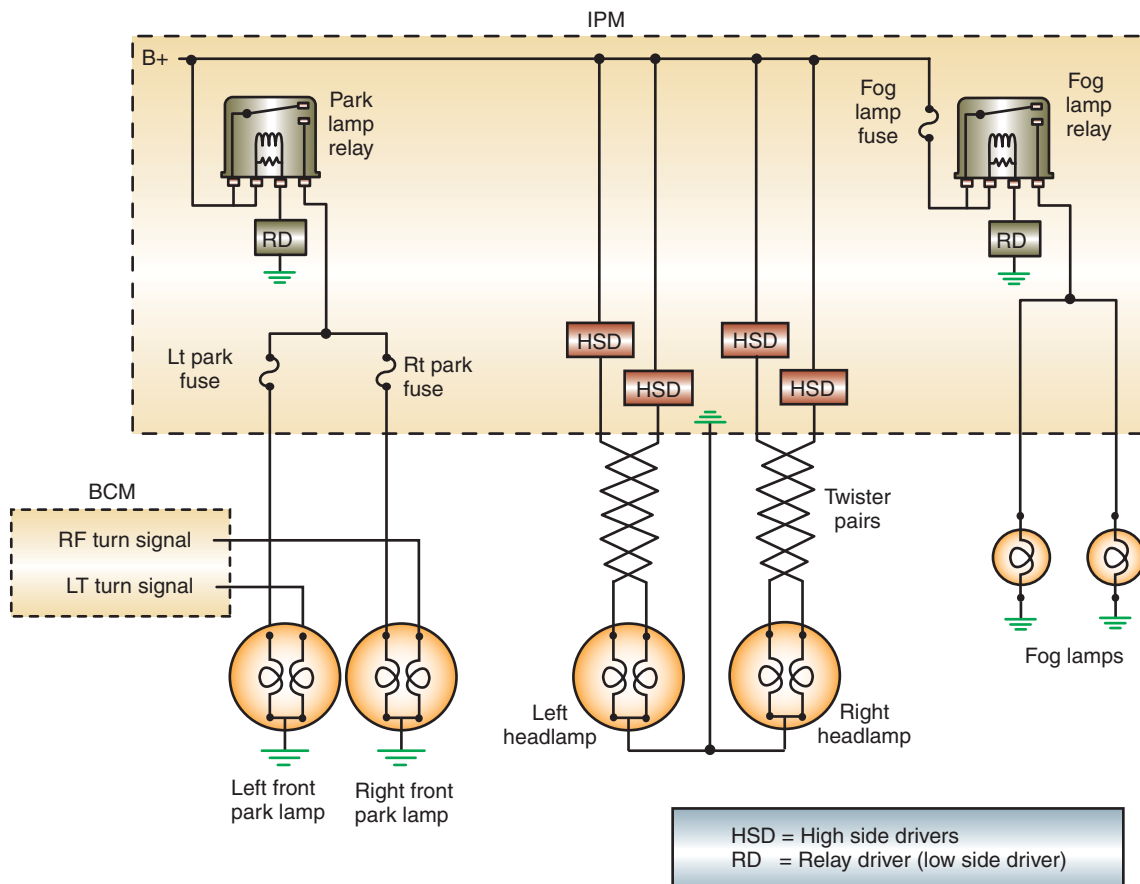
© Delmar/Cengage Learning

**FIGURE 12-2** The body computer controls the relay of the headlight system.

Voltage is also applied to the multifunction switch (dimmer switch function). If the multifunction switch is placed in the high-beam position, it will complete the path for the flow of current to the coil of the high-beam headlight relay. Since this relay is connected to ground, the coil is energized and the contacts move to supply current to the high-beam lamps. The low-beam relay must be energized to turn on the high beams unless the flash-to-pass function is being performed. The flash-to-pass function of the multifunction switch bypasses the BCM control of the circuit.

Park and fog light relays are controlled in the same fashion. Since the BCM controls the operation of the relays, it can turn off the exterior lights if the driver forgets to do so. Once the ignition switch is turned off, a timer is started. After a programmed length of time, the BCM will turn off all the relays associated with the exterior lighting system, even if the switch is still in the headlight position.

A more sophisticated system uses high side drivers (HSD) (Figure 12-3). In the example shown, the lamp and fog lamp relays are controlled, as previously described, using low side drivers (relay drivers). The difference is that the headlight switch input is sent to the BCM, then the BCM sends the request to the integrated power module (IPM). The IPM then turns on and off the relays as needed. The operation of the headlights is unique. Based on the input from the headlight switch, the BCM sends the requested state to the IPM. The IPM then turns on the headlights by supplying power from the HSDs. This system does not require relays or fuses because the HSDs perform these functions. If a high current condition occurs, the HSDs sense this and turn off the circuit until the cause of the high current is no longer present. The output of the HSDs is pulse width modulated at a frequency of 90 Hz in order to maintain a constant 13.5 volts to the headlight bulbs, relative to battery voltage. This is done



**FIGURE 12-3** Headlight circuit that uses high side drivers.

to increase the life of the headlight bulbs. In addition, the HSDs can perform diagnostics of the system, set DTCs, and turn on indicator lights to notify the driver of a malfunction.

## AUTOMATIC ON/OFF WITH TIME DELAY

**AUTHOR'S NOTE:** This system is given several different names by the various manufacturers. Some of the more common names include: Twilight Sentinel, Auto-lamp/Delayed Exit, and Safeguard Sentinel.

### Shop Manual

Chapter 12,  
page 492

The **automatic on/off with time delay** has two functions: to turn on the headlights automatically when ambient light decreases to a predetermined level and to allow the headlights to remain on for a certain amount of time after the vehicle has been turned off. The common components of the automatic on/off with time delay include:

1. Photocell and amplifier.
2. Power relay.
3. Timer control.

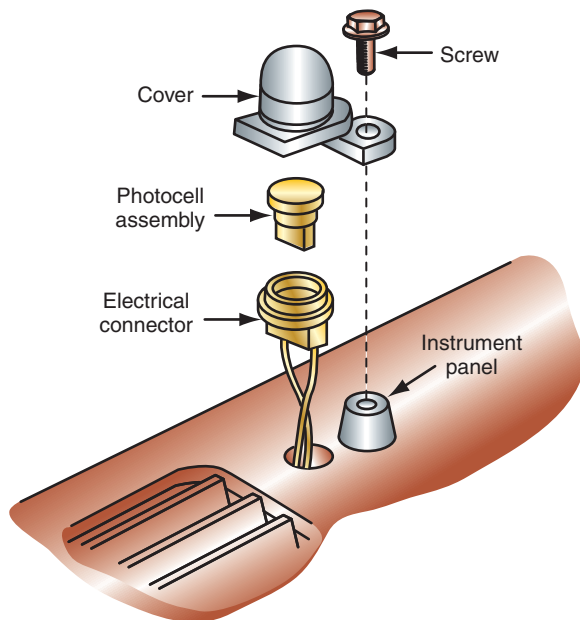
In a typical automatic on/off with time delay headlight system, a photocell is located inside the vehicle's dash to sense outside light (Figure 12-4). In most systems, the headlight switch must be in the OFF or AUTO position to activate the automatic mode (Figure 12-5). Battery voltage is applied to the normally open headlight contacts of the relay through the headlight switch. Battery voltage is also supplied to the normally open exterior light contacts through the fuse panel (Figure 12-6).

### Shop Manual

Chapter 12,  
page 492

To activate the automatic on/off feature, the photocell and amplifier must receive voltage from the ignition switch. As the ambient light level decreases, the internal resistance of the photocell increases. When the resistance value reaches a predetermined level, the photocell and amplifier trigger the sensor-amplifier module. The sensor-amplifier module energizes the relay, turning on the headlights and exterior parking lights (Figure 12-7).

Early systems use a **timer control** that uses a potentiometer that is part of the headlight switch. The timer control unit controls the automatic operation of the system and the length



**FIGURE 12-4** Most automatic on/off headlight systems have the photocell located in the dash to sense incoming light levels.

© Delmar/Cengage Learning

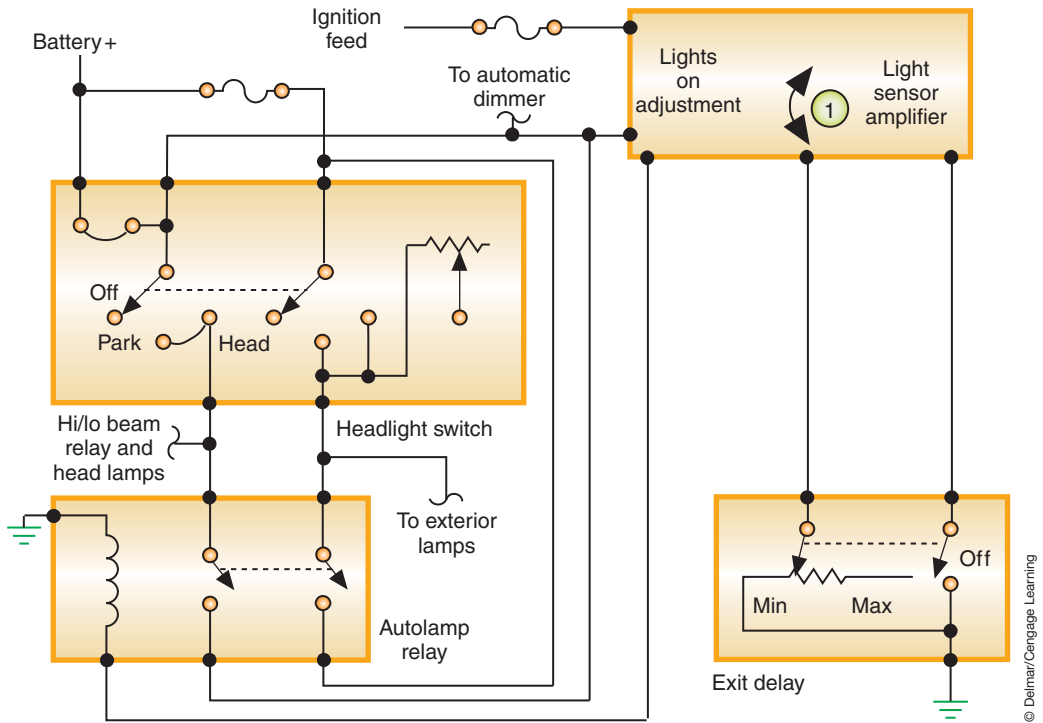


FIGURE 12-5 Schematic of automatic headlight on/off with time delay system.

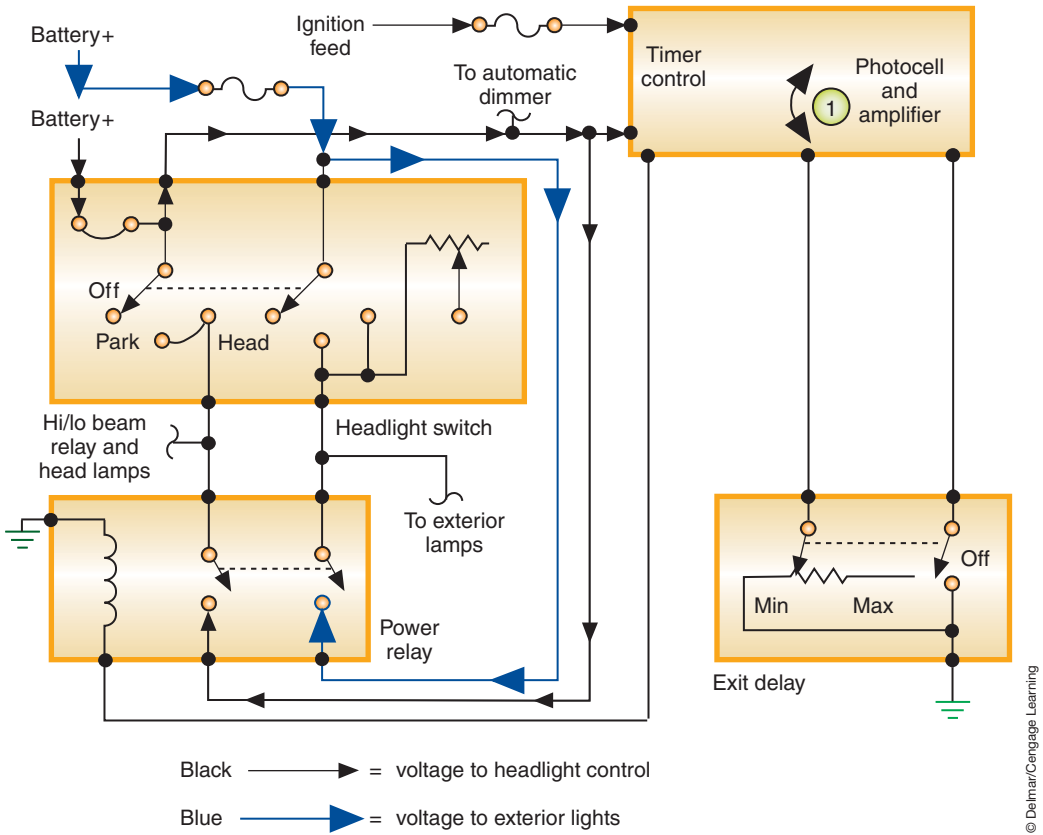
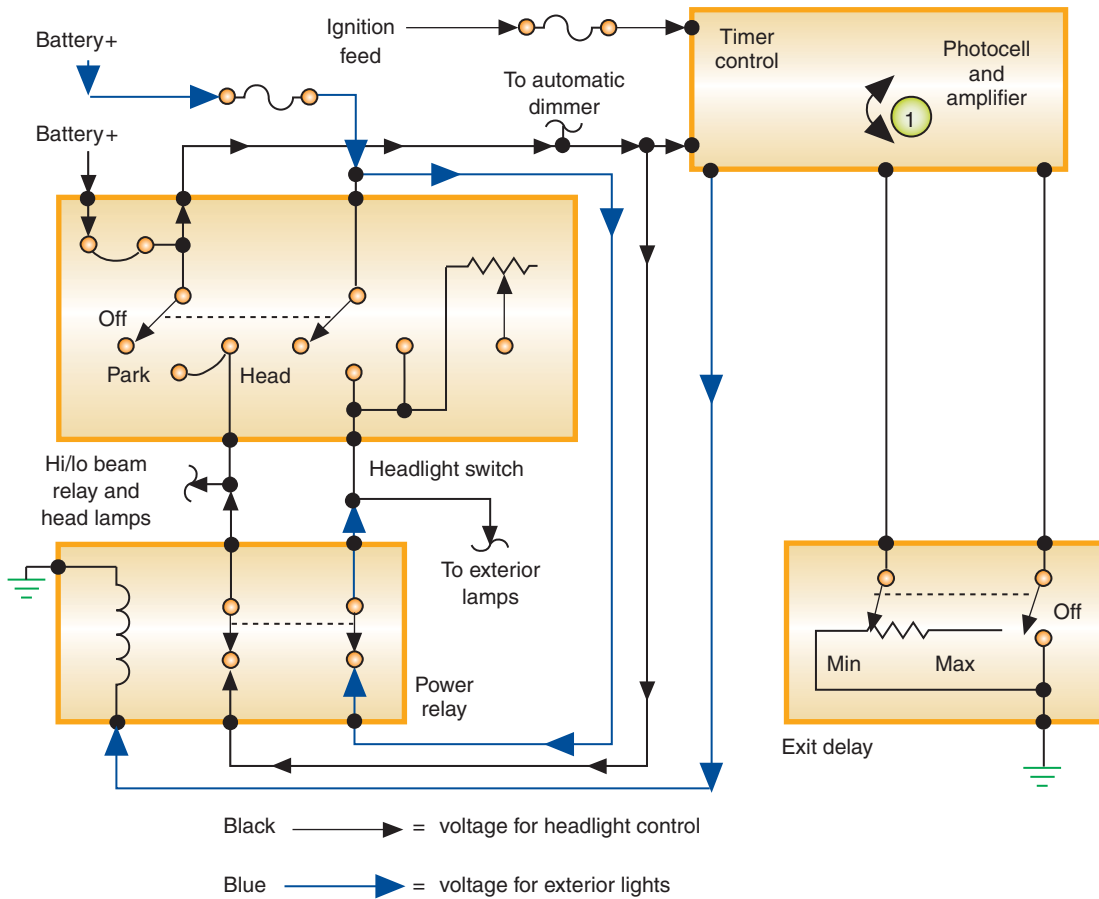


FIGURE 12-6 Current flow in automatic mode with the headlights off.



**FIGURE 12-7** Current flow in the automatic mode with the headlights on.

© Delmar/Cengage Learning

of time the headlights stay on after the ignition switch is turned off. The timer control signals the sensor-amplifier module to energize the relay for the requested length of time.

If the headlights are on when the ignition switch is turned off, the photocell and amplifier's ignition switch voltage is opened. This activates a timer circuit in the amplifier. The amplifier still receives battery voltage from the headlight switch and uses this voltage to keep the relay energized for the requested time interval. When the preset length of time has passed, the amplifier module removes power to the relay and the headlights (and exterior lights) turn off.

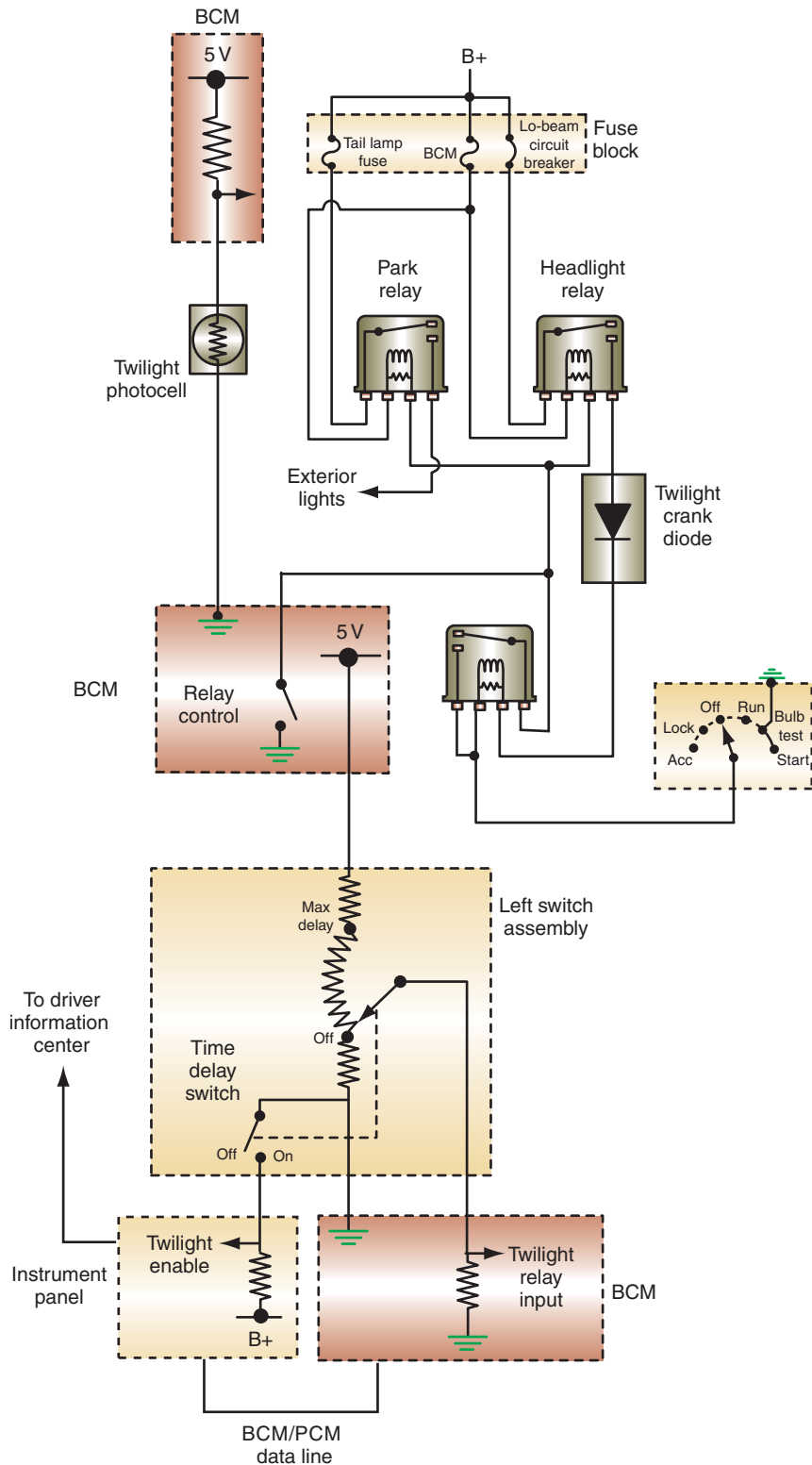
The driver can override the automatic on/off feature by placing the headlight switch in the ON position. This bypasses the relay and sends battery voltage directly to the headlight circuit.

**AUTHOR'S NOTE:** The Twilight Sentinel System is overridden when the delay control switch is in the OFF position. The delay control switch is located on the left switch panel.

Depending on model application, General Motors' Twilight Sentinel System can use the body computer to control system operation (Figure 12-8). The body control module (BCM) senses the voltage drop across the photocell and the delay control switch. The delay control switch resistance is wired in series with the photocell. If the ambient light level drops below a specific value, the BCM grounds the headlamp and parklamp relay coils. The BCM also keeps the headlights on for a specific length of time after the ignition switch is turned off.

Most newer systems continue to use the same principle of using the photocell as the early systems for automatic headlight operation. The difference is that the time control is a





© Delmar/Cengage Learning

**FIGURE 12-8** Some systems use the BCM to sense inputs from the photocell and delay control switch.

function of the module (usually the BCM). An interface module such as the instrument panel or overhead console provides a means for the driver to select the desired amount of time delay after the ignition switch is turned off. The BCM keeps the headlight relay energized for the length of time programmed. When the ignition switch is turned off, all other relays controlling exterior lighting are de-energized except the headlight relay.

## AUTOMATIC HEADLIGHT DIMMING

Modern **automatic headlight dimming** systems use solid-state circuitry and electromagnetic relays to control the beam switching. Automatic headlight dimming automatically switches the headlights from high beams to low beams under two different conditions: when light from oncoming vehicles strikes the photocell-amplifier or light from the taillights of a vehicle being passed strikes the photocell-amplifier. Most systems consist of the following major components:

1. Light-sensitive **photocell** and amplifier unit.
2. High-low beam relay.
3. Sensitivity control.
4. Dimmer switch.
5. Flash-to-pass relay.
6. Wiring harness.

The photocell-amplifier is usually mounted behind the front grill, but ahead of the radiator. The **sensitivity control** sets the intensity level at which the photocell-amplifier will energize. This control is set by the driver and is located next to, or is a part of, the headlight switch assembly (Figure 12-9). The driver is able to adjust the sensitivity level of the system by rotating the control knob. An increase in the sensitivity level will make the headlights switch to the low beams sooner (approaching vehicle is farther away). A decrease in the sensitivity level will switch the headlights to low beams when the approaching vehicle is closer. If the knob is rotated to the full counterclockwise position, the system goes into manual override.

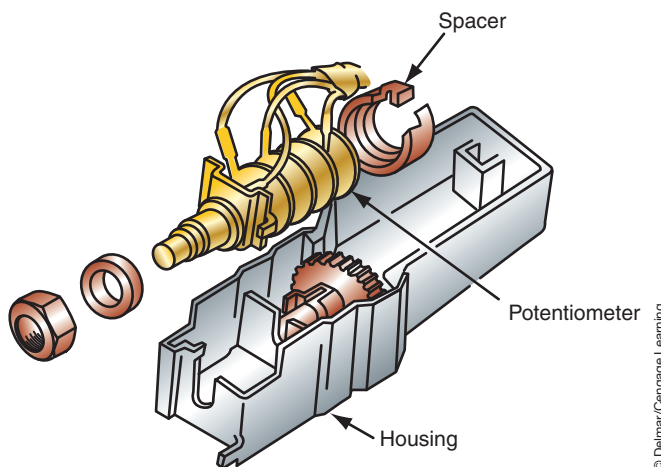
**AUTHOR'S NOTE:** Many vehicle manufacturers install the sensor-amplifier in the rearview mirror support.

The high–low relay is a single-pole, double-throw unit that provides the switching of the headlight beams. The relay also contains a clamping diode for electrical transient damping to protect the photocell and amplifier assembly.

The dimmer switch is usually a flash-to-pass design. If the turn signal lever is pulled part-way up, the flash-to-pass relay is energized. The high beams will stay on as long as the lever is held in this position, even if the headlights are off. In addition, the driver can select either low beams or automatic operation through the dimmer switch.

Although the components are similar in most systems, there are differences in system operations. Systems differ in how the manufacturer uses the relay to do the switching from high beams

The **photocell** is like a variable resistor that uses light to change resistance.



**FIGURE 12-9** The driver sets the sensitivity of the automatic headlight dimmer system by rotating the potentiometer to change resistance values.

to low beams. The system can use either an energized relay to activate the high beams or an energized relay to activate the low beams. If the system uses an energized relay to activate the high beams, the relay control circuit is opened when the dimmer switch is placed in the low-beam position or the driver manually overrides the system (Figure 12-10). With the headlight switch in the ON position and the dimmer switch in the low-beam position, battery voltage is not applied to the relay coil and the relay coil is not energized. Since the dimmer switch is in the low-beam position, it opens the battery feed circuit to the relay coil and the automatic feature is bypassed.

With the dimmer switch in the automatic position, battery feed is provided for the relay coil (Figure 12-11). Ground for the relay coil is through the sensor-amplifier. The energized coil closes the relay contacts to the high beams and battery voltage is applied to the headlamps. When the photocell sensor receives enough light to overcome the sensitivity setting, the amplifier opens the relay's circuit to ground. This de-energizes the relay coil and switches battery voltage from the high-beam to the low-beam position.

If the system uses an energized relay to switch to low beams, placing the dimmer switch in the low-beam position will energize the relay. With the headlights turned on and the dimmer

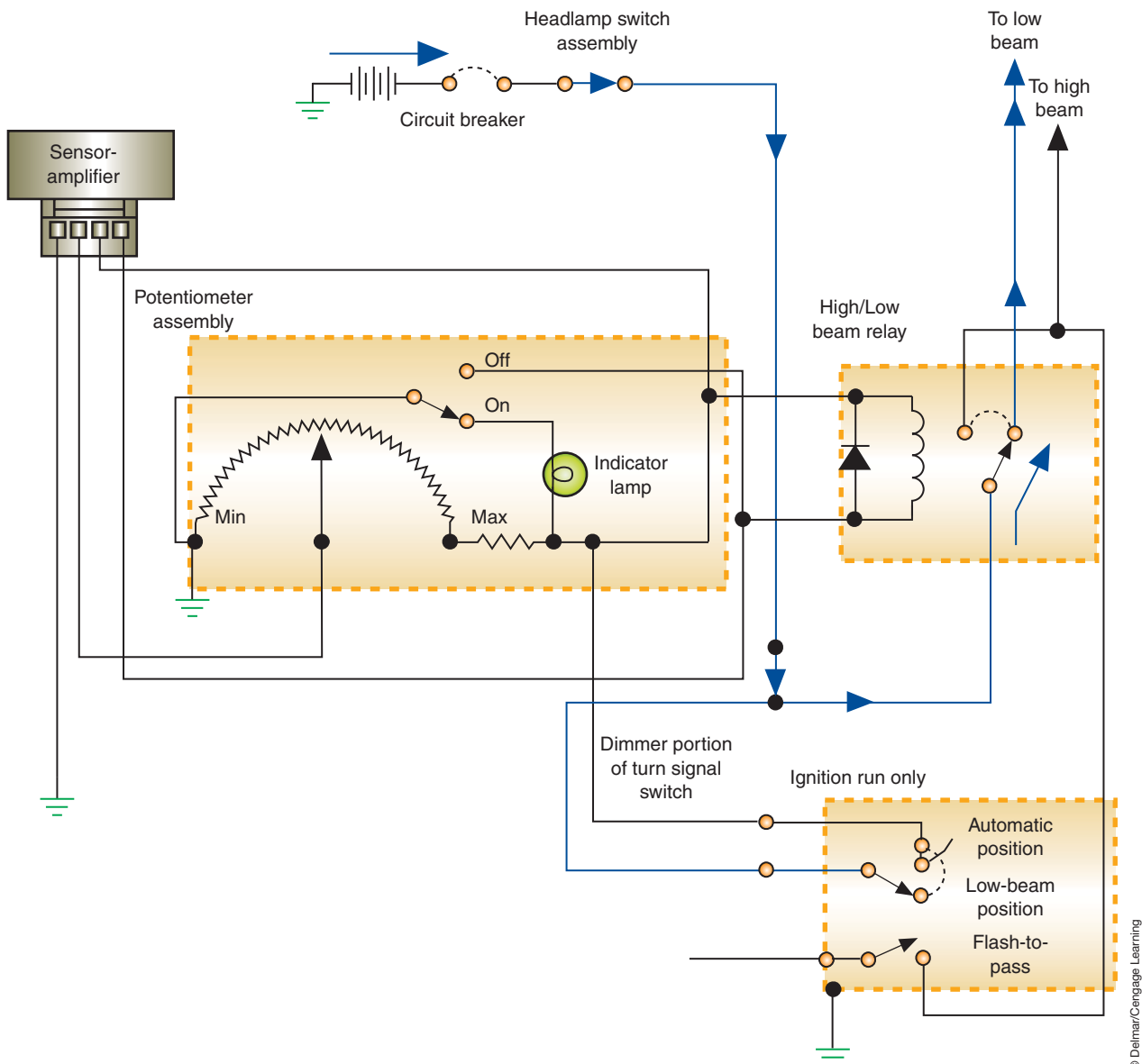
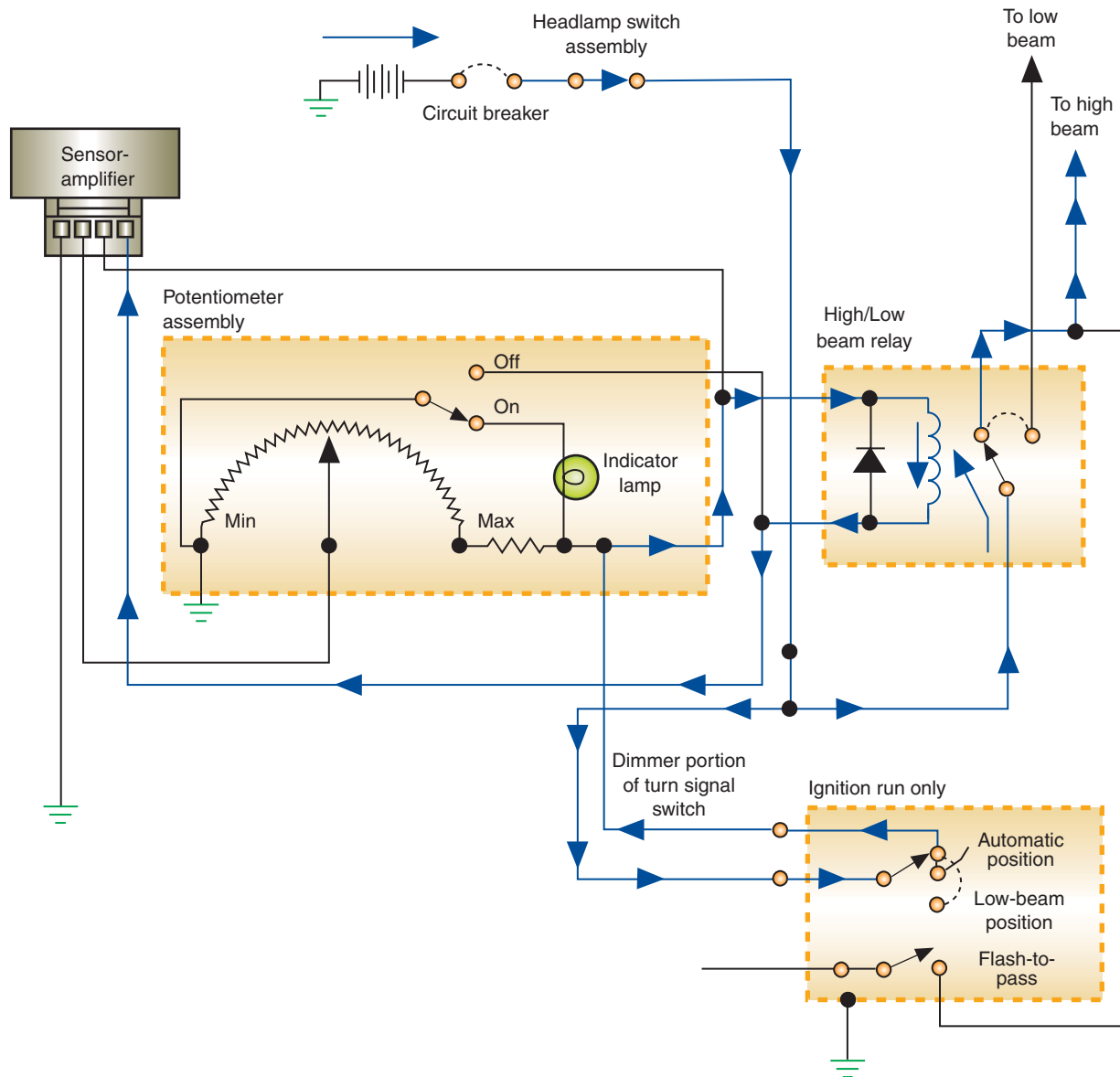


FIGURE 12-10 Automatic headlight dimming circuit with the dimmer switch located in the LOW-BEAM position.



© Delmar/Cengage Learning

**FIGURE 12-11** Automatic headlight dimming circuit with the dimmer switch located in the automatic position and no oncoming light sensed.

switch in the automatic position, battery voltage is applied to the photocell-amplifier, one terminal of the high–low control, and through the relay contacts to the high beams. The voltage drop through the high–low control is an input to the photocell-amplifier. When enough light strikes the photocell-amplifier to overcome the sensitivity setting, the amplifier allows battery current to flow through the high–low relay, closing the contact points to the low beams. Once the light has passed, the photocell-amplifier opens battery voltage to the relay coil and the contacts close to the high beams.

When flash-to-pass is activated, the switch closes to ground. This bypasses the sensitivity control and de-energizes the relay to switch from low beams to high beams.

Today the headlight system can be very sophisticated. The following is an example of how the SmartBeam system used by some manufacturers performs auto headlamp and auto high-beam operation. This system provides lighting levels based on conditions and will operate the high beams by sensing light levels.

The SmartBeam system uses a forward-facing, 5,000-pixel, digital imager camera that is attached to the rearview mirror mount (Figure 12-12). The camera’s field of vision is in front of the vehicle within 2 degrees of the vehicle’s centerline and 10 degrees of horizontal.

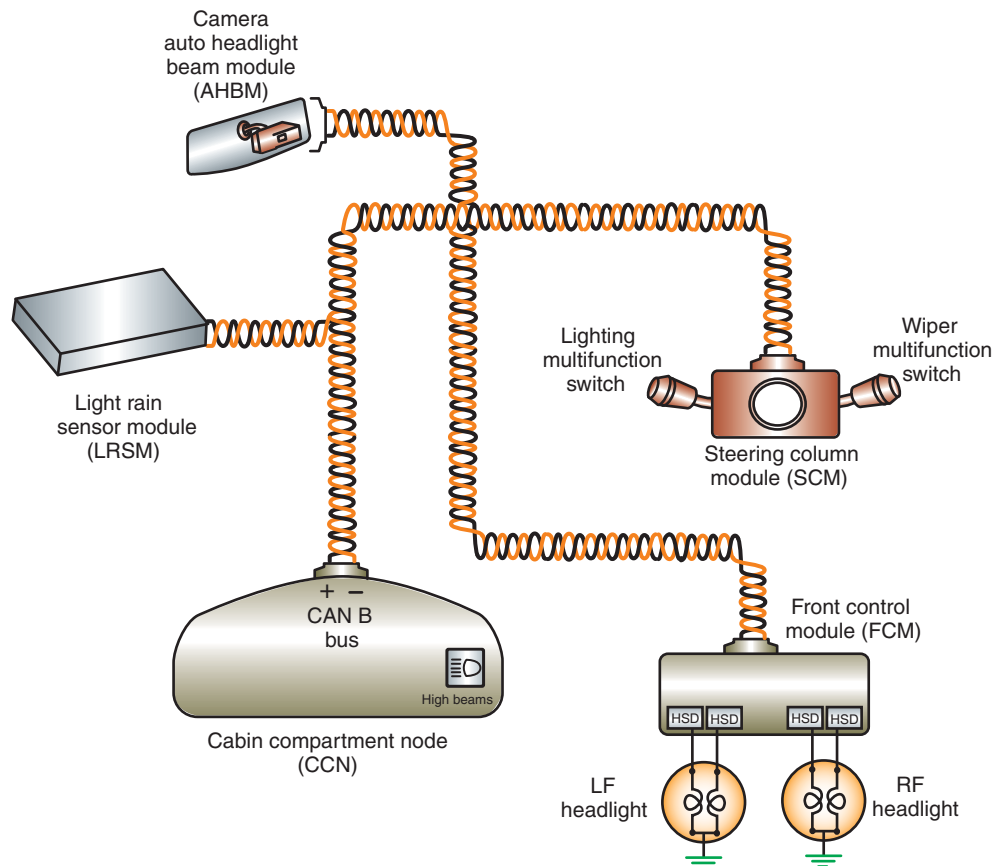
**Shop Manual**  
Chapter 12,  
page 496



© Delmar/Cengage Learning

**FIGURE 12-12** The SmartBeam auto headlight system uses a digital camera to determine oncoming light intensity.

The operation of SmartBeam requires interaction with several vehicle modules. Figure 12-13 shows how one system interacts between modules. Ambient light levels for automatic headlight operation are provided by the light rain sensor module (LRSM), if equipped. If the LRSM is not used on the vehicle, then the system will use a photocell located on top of the dash. The headlamp switch position is signaled by the lighting multifunction switch and is an input to the steering column module (SCM). The SCM sends switch position status over the data bus. The front control module (FCM) uses HSDs to provide power to the both low- and high-beam bulbs. The cabin compartment node (CCN) controls the operation of the high-beam indicator.



© Delmar/Cengage Learning

**FIGURE 12-13** The auto headlight system integrates several modules.

The decisions made for headlight intensity are based on the sensed intensity of light, the light's location, and the light's movement. The system is capable of distinguishing between light types, such as mercury vapor used for street lighting. In addition, it can distinguish colors, so it is possible to identify the red lights used on taillamps and sign colors. Distinguishing light types and colors is done by identifying the wave length of the light source. If it is determined that the approaching light source is another vehicle, a data bus message is sent from the auto high-beam module (AHBM) to the module that controls headlight operation (FCM in this case) to deactivate the high beams.

For this system to be operational, the headlight switch must be placed in the auto headlamp position and the "LOW/HIGH BEAM" option must be selected from the configurable display (Figure 12-14). The engine must also be running for the auto headlight function to operate. For the SmartBeam function to operate, the vehicle speed must be over 20 mph.

The auto headlight function will use either a photocell in the dash or a part of the mirror assembly to sense ambient light intensity. When the engine is running and the ambient light levels are less than 1000 LUX, the auto headlamp low beam becomes operational. LUX is the International System unit of measurement of the intensity of light. It is equal to the illumination of a surface one meter away from a single candle (one lumen per square meter).

Once vehicle speed exceeds 20 mph, if the ambient light level sensed at the SmartBeam camera is 5 LUX or less, a PWM voltage is applied to the high-beam circuit by the controlling module (FCM). Within 2½ to 5 seconds, the high beams will be at full intensity. By using PWM, the high beams are ramped up and down; this eliminates the usual "flash" that occurs as the high beams are turned on and off. Drivers in oncoming vehicles do not see any indication of the beam change since it is gradual and based on distance.

When another vehicle approaches, the camera determines the light intensity from its headlights. Once the light intensity reaches a predetermined level, a bus message is sent to the control module (FCM) to deactivate the high beams. The voltage to the high beams is ramped down using PWM until they are turned off.

**AUTHOR'S NOTE:** Federal law specifies that the high-beam indicator is turned on at the initial start of the ramping up to high-beam operation and that it remains on during all high-beam operation. High beam is considered in operation throughout the ramp down phase; thus, the indicator light stays on until the high beams are totally turned off.



**FIGURE 12-14** For the auto headlight system to operate, the drive must activate it.



If the driver uses the high-beam switch to manually turn on the high beams, SmartBeam operation is defeated. Also, the system is momentarily defeated if the driver uses the flash-to-pass function. If the headlamp switch is placed in any other position other than AUTO, both the auto headlamp and SmartBeam functions are defeated.

Initial camera calibration and verification are performed at the factory as the vehicle is near completion. During this time the camera is precisely aligned. Once the camera is properly aligned, logic used by the AHBM will make adjustments to fine-tune the alignment based on sensed lighting inputs while the vehicle is driven. These adjustments occur as the processing logic looks for a light source that represents oncoming headlights. This would include light sources that start as low intensity and then gradually increase in brightness and have movement, indicating a gradual rate of approach. In addition, the light source must be coming from just to the left of center. These conditions indicate a vehicle is approaching from a distance. The computer logic of the AHBM will apply a weighting factor to its calibration to correct the aim. If the system is out of calibration, the LED in the mirror will flash.

## HEADLIGHT LEVELING

Some European and Asian markets require a **headlight leveling system (HLS)**. These systems can also be found on import vehicles from these market areas. The HLS uses front lighting assemblies with a leveling actuator motor. Some systems use a leveling switch that the driver controls. The switch will allow the headlights to be adjusted into different vertical positions (usually four). This allows the driver to compensate for headlight position that can occur when the vehicle is loaded.

Electrical motors use a pushrod assembly to change the position of the headlight reflector. When different voltage levels are inputted to leveling motors from the multiplexed switch, the motors move the reflector to the selected position.

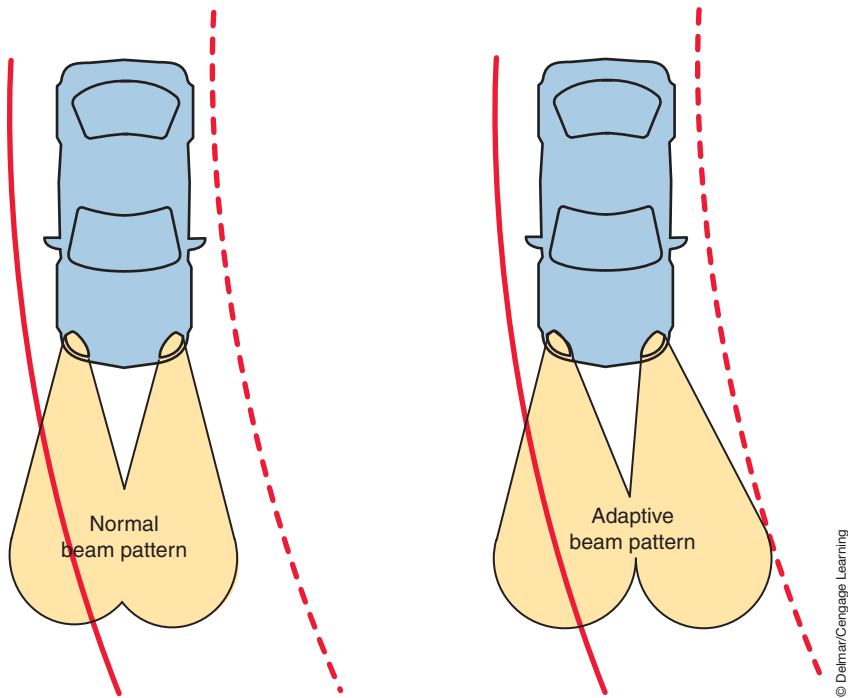
## ADAPTIVE HEADLIGHTS

The **adaptive headlight system (AHS)** is designed to enhance night-time safety by turning the headlight beams to follow the direction of the road as the vehicle enters a turn (Figure 12-15). This provides the driver additional reaction time if approaching any road hazards. Conventional fixed headlights illuminate the road straight in front of the vehicle only. On turns, the light beam can shine onto oncoming traffic or leave the road beyond the turn in darkness. The AHS uses headlight assemblies that swivel into the direction the vehicle is steering. This provides a 90% improvement in illumination of the road so obstacles become visible sooner.

The AHS uses sensors that measure vehicle speed, steering angle, and yaw (degree of rotation around the vertical axis). Based on this information, small electric motors turn the headlights so the beam falls on the road ahead, guiding the driver into the turn (Figure 12-16). The headlights can follow the bends of the road through an arc of 15 degrees. The headlight located on the side of the vehicle opposite the direction of turn will rotate about 7 degrees.

**AUTHOR'S NOTE:** The AHS is activated whenever the vehicle is traveling forward. If the vehicle is in reverse, or if the steering wheel is turned when the vehicle is not moving then the AHS is deactivated.

Some systems are capable of “predicting” the arrival of the vehicle at a turn. These systems not only use steering angle, vehicle speed, and yaw rate inputs; but also GPS-fed road data. They not only adjust the rotation of the headlamp motors, but will also adjust the pattern of illumination of the bi-xenon lamps.



**FIGURE 12-15** The adaptive headlight system will illuminate the road beyond a turn for added safety.

© Delmar/Cengage Learning



**FIGURE 12-16** The adaptive headlight assembly use motors to rotate the beam.

© Delmar/Cengage Learning

## Night Vision

The **night vision** system uses an infrared camera to transfer images to a display panel to enable the driver to identify and react to obstacles outside of the headlight range (Figure 12-17). The infrared camera captures images based on heat. Warm objects such as pedestrians or animals appear on the display as bright shapes. Some systems provide a panning function that turns the camera image automatically when the vehicle is cornering. This enables the driver to detect pedestrians or animals in the approaching turn.



© Delmar/Cengage Learning

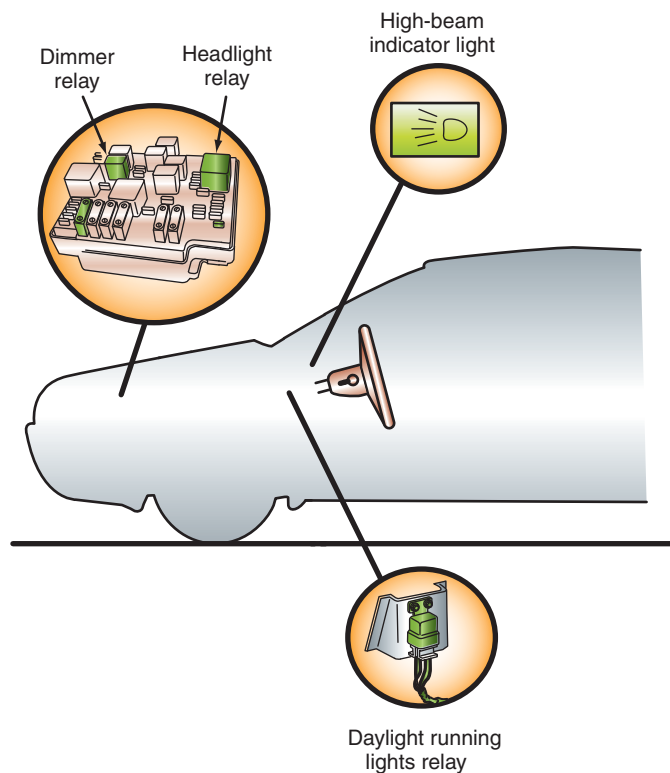
**FIGURE 12-17** Night vision uses an infrared camera to project object onto a screen. The objects may be out of the range of the headlights.

**Shop Manual**

Chapter 12,  
page 505

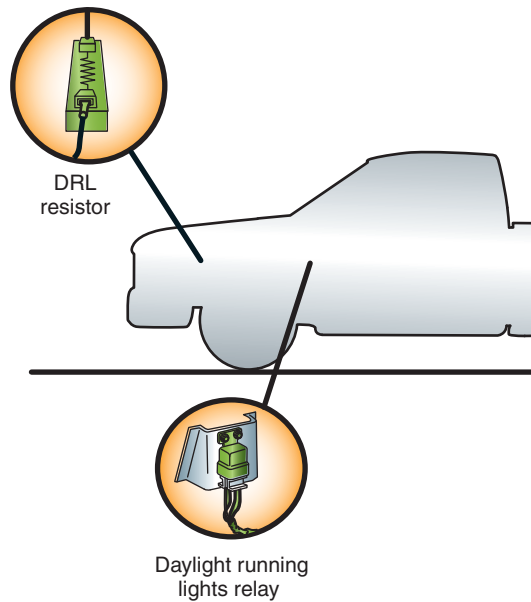
## DAYTIME RUNNING LAMPS

All late-model Canadian vehicles and many domestic vehicles are equipped with **daytime running lamps (DRL)**. The basic idea behind DRLs is dimly lit headlamps during the day. This allows other drivers and pedestrians to see the vehicle from a distance. Manufacturers have taken many different approaches to achieve this lighting. Most have a control module or relay (Figure 12-18) that turns the lights on when the engine is running and allows normal headlamp operation when the driver turns on the headlights. Daytime running lamps generally use the high-beam or low-beam headlight system at a reduced intensity.



© Delmar/Cengage Learning

**FIGURE 12-18** A daytime running light relay.



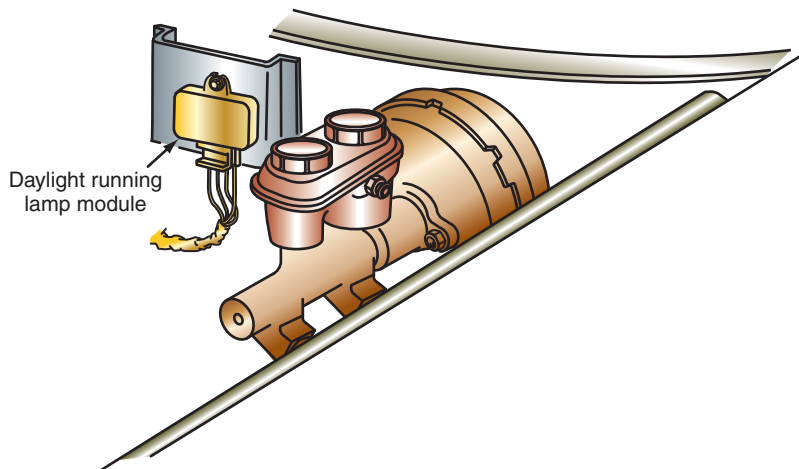
© Delmar/Cengage Learning

**FIGURE 12-19** A resistor in-line with the headlights reduces the current going to the headlights.

The dimmer headlights can result from headlight current passing through a resistor during daylight hours (Figure 12-19). The resistor reduces the voltage available and the current flowing through the circuit to the headlights. The resistor is bypassed during normal headlamp operation.

Other systems use a control module (Figure 12-20), which uses a duty cycled output to either the high-beam or low-beam headlights (depending on manufacturer). The duty cycle reduces the output of the headlights by 50 to 75%. Most systems that use the high-beam headlights have a method of turning off the high-beam indicator lamp in the instrument cluster if DRLs are activated. However, on some systems, it is normal for the high-beam indicator to be dimly lit during DRL operation.

GM's DRL system includes a solid-state control module assembly, a relay, and an ambient light sensor assembly. The system lights the low-beam headlights at a reduced



© Delmar/Cengage Learning

**FIGURE 12-20** A DRL system that uses a control module to pulse current to the high-beam headlights. This results in reduced illumination.

intensity when the ignition switch is in the RUN position during daylight. The DRL system is designed to light the low-beam headlamps at full intensity when low-light conditions exist.

As the intensity of the light reaching the ambient light sensor increases, the electrical resistance of the sensor assembly decreases. When the DRL control module assembly senses the low resistance, the module allows voltage to be applied to the DRL diode assembly and then to the low-beam headlamps. Because of the voltage drop across the diode assembly, the low-beam headlamps are on with a low intensity.

As the intensity of the light reaching the ambient light sensor decreases, the electrical resistance of the sensors increases. When the DRL module assembly senses high resistance in the sensor, the module closes an internal relay, which allows the low-beam headlamps to illuminate with full intensity.

If the normal headlights are controlled by PWM from a high-side driver (refer to Figure 12-3), the DRLs are controlled by the same drivers. The headlight switch inputs to the computer if the switch position is in the OFF or AUTO modes of operation. In these modes, DRL is activated by PWM of the voltage to the lamps at a reduced rate. The low PWM results in low luminous output of the lamps.

**AUTHOR'S NOTE: BMW uses a DRL system that are integrated into the corona rings of the HID headlights.**

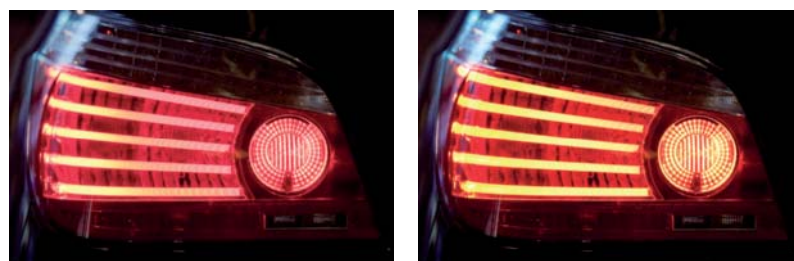
Most DRL systems also use the parking brake switch as an input. If the parking brake is applied while the engine is running, the daytime running light feature is turned off.

## ADAPTIVE BRAKE LIGHTS

Since normal brake lights behave the same regardless of how hard the brakes are being applied, drivers behind the vehicle that is stopping have no indication if the vehicle is stopping under normal or emergency conditions. The BMW X6 and other vehicles are using an **adaptive brake light** system that selects different illumination levels or methods of display for the rear brake lights depending on conditions. This increases the visibility of the vehicle to other drivers and provides them with greater information concerning the events ahead of them.

One method is to use the normal brake lights (including the CHMSL) during moderate braking events. However, under intense braking or ABS braking intervention, additional lights in the tail lamp assembly are used (Figure 12-21). This increases the intensity of the brake light assembly. Another method is to use the normal brake lights during moderate braking. However, during intense braking or ABS intervention, the rear brake lights will blink several times per second.

Regardless of the method of display, the adaptive brake light system uses information gathered from sensors used by the ABS module and vehicle speed to determine the rate of deceleration and to calculate the intensity of the braking event.



**FIGURE 12-21** Adaptive brake lights can use two illumination levels. Left is normal braking, while the right photo is during hard braking.

© Delmar/Cengage Learning



## ILLUMINATED ENTRY SYSTEMS

**Illuminated entry systems** turn on the courtesy lights before the doors are opened. Most modern illuminated entry systems incorporate solid-state circuitry that includes an illuminated entry actuator and side door switches in the door handles. Illumination of the door lock tumblers can be provided by the use of fiber optics or light-emitting diodes.

When either of the front door handles is lifted, a switch in the handle will close the ground path from the actuator. This signals the logic module to energize the relay (Figure 12-22). With the relay energized, the contacts close and the interior and door lock lights come on. A timer circuit is incorporated that will turn off the lights after 25 to 30 seconds. If the ignition switch is placed in the RUN position before the timer circuit turns off the interior lights, the timer sequence is interrupted and the interior lights turn off.

Some manufacturers have incorporated the illuminated entry actuator into their BCM (Figure 12-23). Activation of the system is identical as discussed. The signal from the door handle switch can also be used as a **“wake-up” signal** to the BCM. A wake-up signal is used to notify the BCM that an engine start and operation of accessories is going to be initiated soon. This signal is used to warm up the circuits that will be processing information.

The signal from the door handle switch informs the body computer to activate the courtesy light driver. Some systems use a pair of door jamb switches that signal the body computer to keep the courtesy lights on when the door is open. When the door is closed and the ignition switch is in the RUN position, the lights are turned off.

Referring to Figure 12-23, this type of system is capable of turning off the interior lights if the driver forgets to turn them off or leaves a door open. After a programmed period of time has elapsed with the ignition in the OFF position and no other inputs received, the BCM will turn off the courtesy lamp driver and turn off the lamps. The battery saver driver is turned on whenever the BCM receives its wake-up signal and provides ground for the lamps through the switches. This allows the vehicle occupants to turn on and off individual reading lights. Once the ignition key is turned off and a programmed length of time has elapsed, the BCM will turn off the battery saver driver. This will assure that all lights are turned off while the vehicle is not being used even though a switch was left in the ON position.

Another feature of this system is fade-to-off. Whenever the BCM determines it will turn off the courtesy lamps (either by the ignition switch being placed in the RUN position or the timer expiring), the driver circuit will gradually change the duty cycle, resulting in the lamps dimming as they go off.

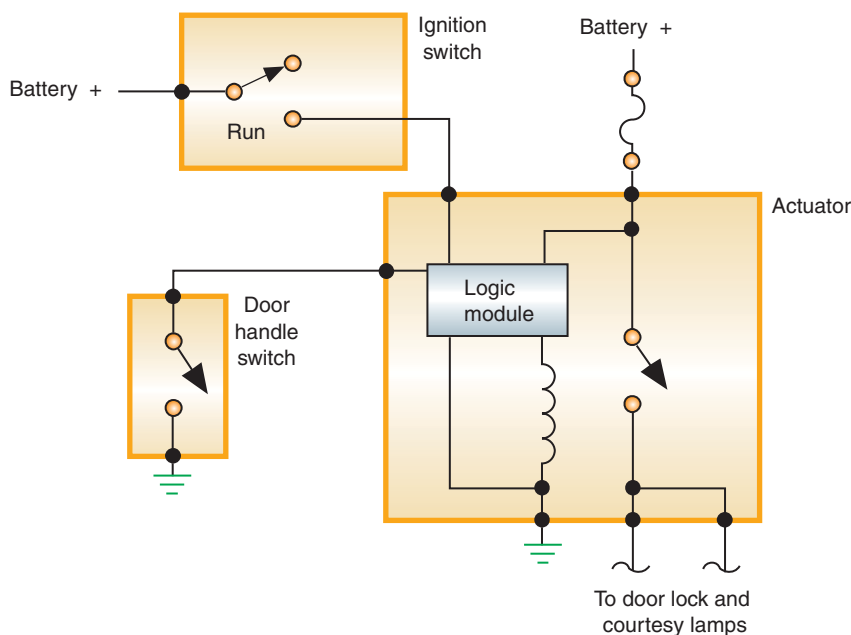


FIGURE 12-22 Illuminated entry actuator circuit.



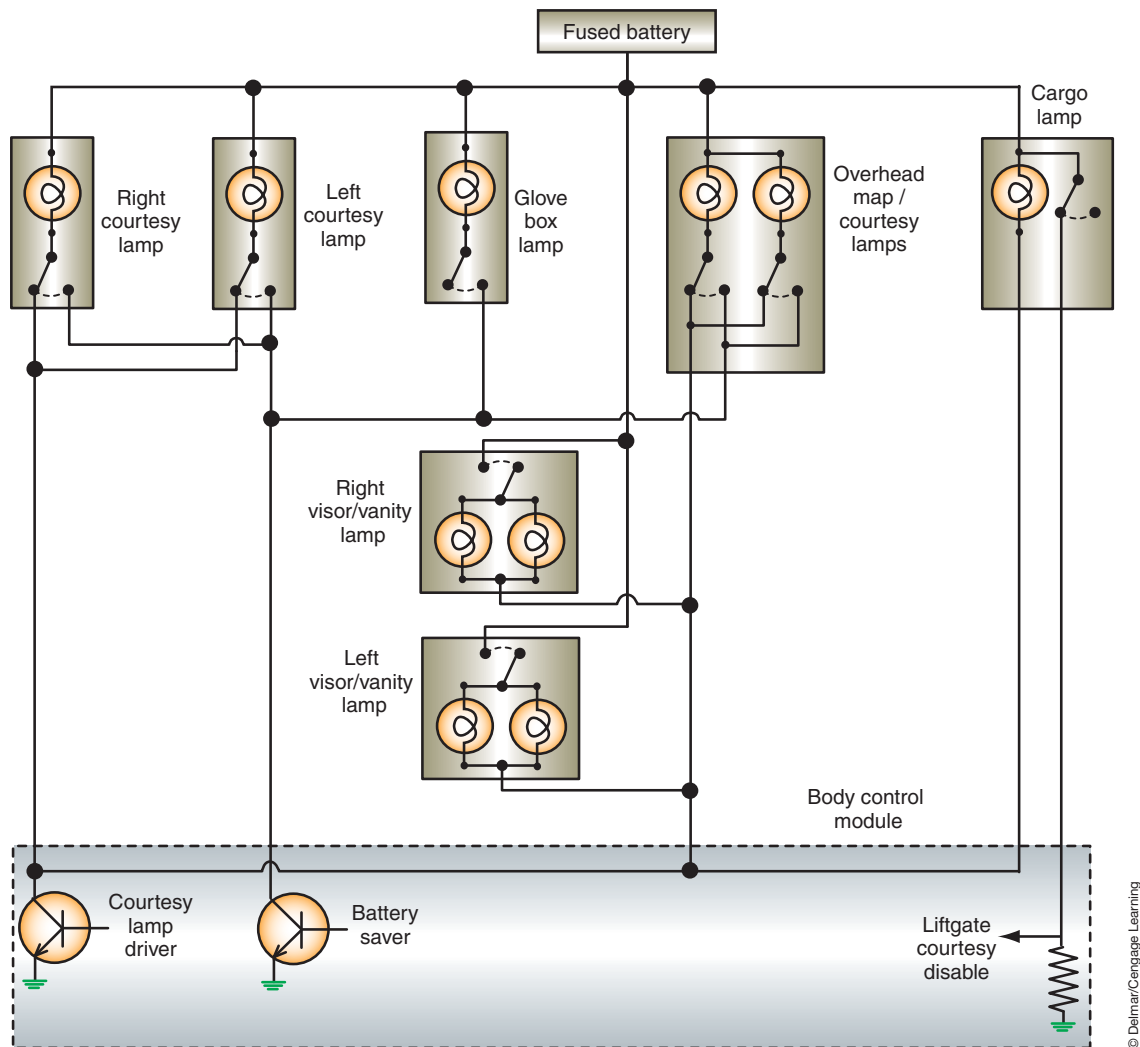


FIGURE 12-23 Body computer control of the illuminated entry system.

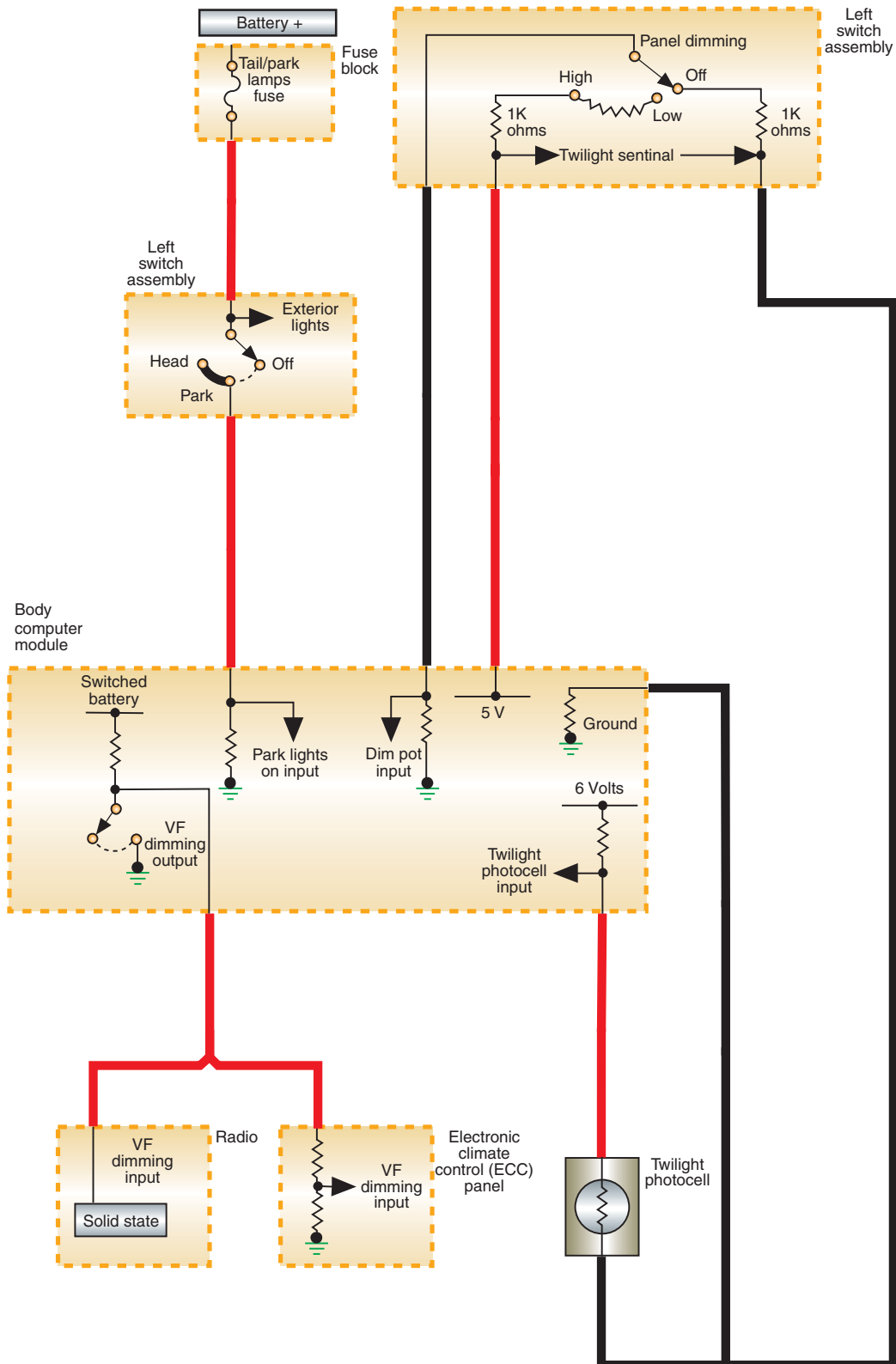
Some manufacturers use the twilight photocell to inform the body computer of ambient light conditions. If the ambient light is bright, the photocell signals the BCM that courtesy lights are not required.

## INSTRUMENT PANEL DIMMING

The BCM can also be used to control the **instrument panel dimming** feature. The body computer uses inputs from the panel dimming control and photocell to determine the illumination level of the instrument panel lights (Figure 12-24). With the ignition switch in the RUN position, a 5-volt signal is supplied to the panel dimming control potentiometer. The wiper of the potentiometer returns the signal to the BCM.

When the dimmer control is moved toward the dimmer positions, the increased resistance results in a decreased voltage signal to the BCM. By measuring the voltage that is returned, the BCM is able to determine the resistance value of the potentiometer. The BCM controls the intensity level of the illumination lamps by pulse-width modulation.

Some digital instrument panel modules use an ambient light sensor in addition to the rheostat. The ambient sensor will control the display brightness over a 35-to-1 range and the rheostat will control over a 30-to-1 range. When the headlights are on, the module compares the values from both inputs and determines the illumination level. When the headlights are off, the module uses only the ambient light sensor for its input.



© Delmar/Cengage Learning

**FIGURE 12-24** The dimming control and photocell are inputs to the BCM to control panel instrument panel dimming.

A variation of this operation is that the BCM will receive the light intensity level request from the headlight rheostat as it did before, but the requested level is then sent to the instrument cluster by the multiplexing circuit. The instrument cluster uses this input information to control lamp intensity through its own microprocessor.

## FIBER OPTICS

Fiber optics is the transmission of light through polymethyl methacrylate plastic that keeps the light rays parallel even if extreme bends are in the plastic. The invention of fiber optics has made it possible to provide illumination of several objects by a single light source (Figure 12-25). Plastic fiber-optic strands are used to transmit light from the source to the object to be illuminated. The strands of plastic are sheathed by a polymer that insulates the light rays as they travel within the strands. The light rays travel through the strands by means of internal reflections.

Fiber optics are commonly used as indicator lights to show the driver that certain lights are functioning. Many vehicles with fender-mounted turn signal indicators use fiber optics from the turn signal light to the indicator (Figure 12-26). The indicator will only show light if the turn signal light is on and working properly.

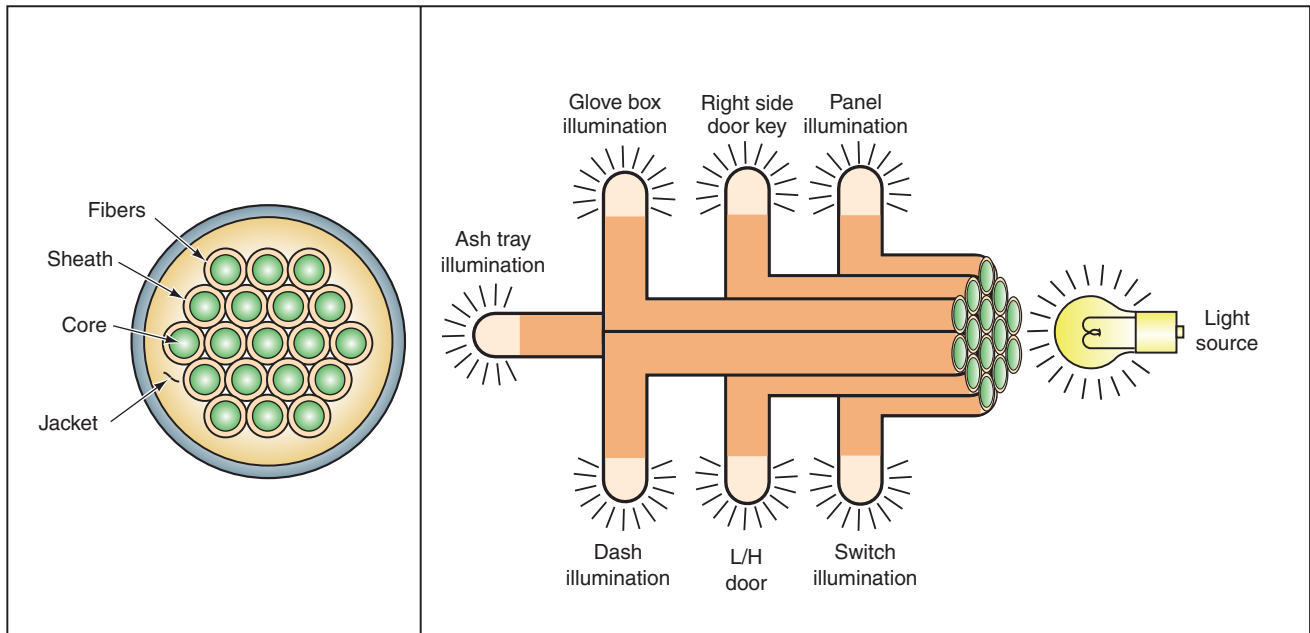


FIGURE 12-25 One light source can illuminate several areas by using fiber optics.

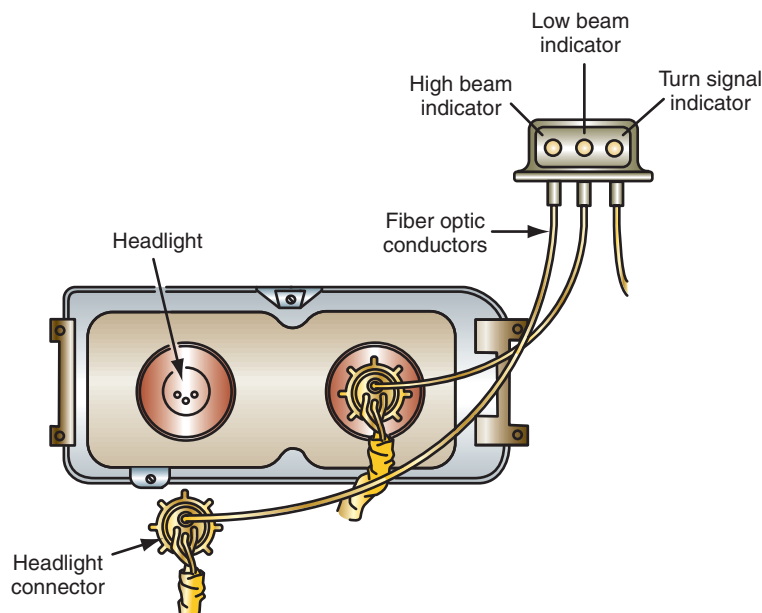


FIGURE 12-26 Fiber optics can be used to indicate the operation of exterior lights to the driver.



## A BIT OF HISTORY

Optical communication systems date back to the “optical telegraph” that French engineer Claude Chappe invented in the 1790s. Alexander Graham Bell patented an optical telephone system, which he called the Photophone, in 1880. During the 1920s, John Logie Baird of England and Clarence W. Hansell of the United States patented the idea of using arrays of hollow pipes or transparent rods to transmit images for television or facsimile systems. However, the first person known to have demonstrated image transmission through a bundle of optical fibers was Heinrich Lamm, a medical student in Munich. His goal was to look inside inaccessible parts of the body and, in a 1930 paper, he reported transmitting the image of a light bulb filament through a short bundle.

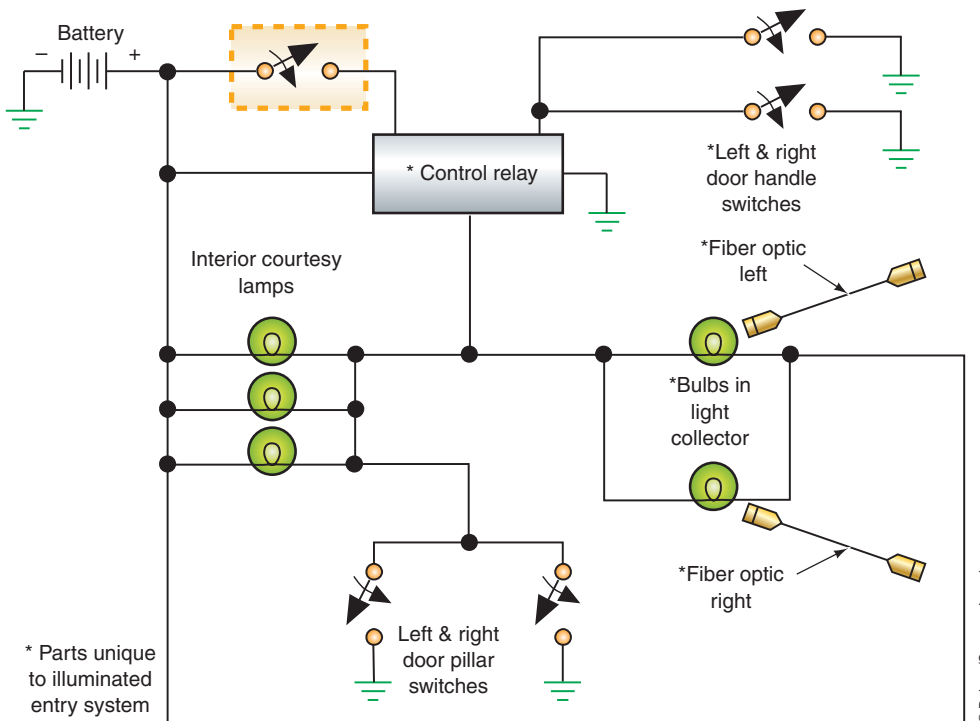


FIGURE 12-27 Fiber optics used in an illuminated entry system.

Some manufacturers use fiber optics to provide illumination of the lock cylinder “halo” during illuminated entry operation (Figure 12-27). When the illuminated entry system is activated, the light collector provides the source light to the fiber optics and the halo lens receives the light from the fiber optic cable.

The advantage of fiber optics is it can be used to provide light in areas where bulbs would be inaccessible for service. Other uses of fiber optics include:

- Lighting ash trays.
- Illuminating instrument panels.
- Dash lighting over switches.

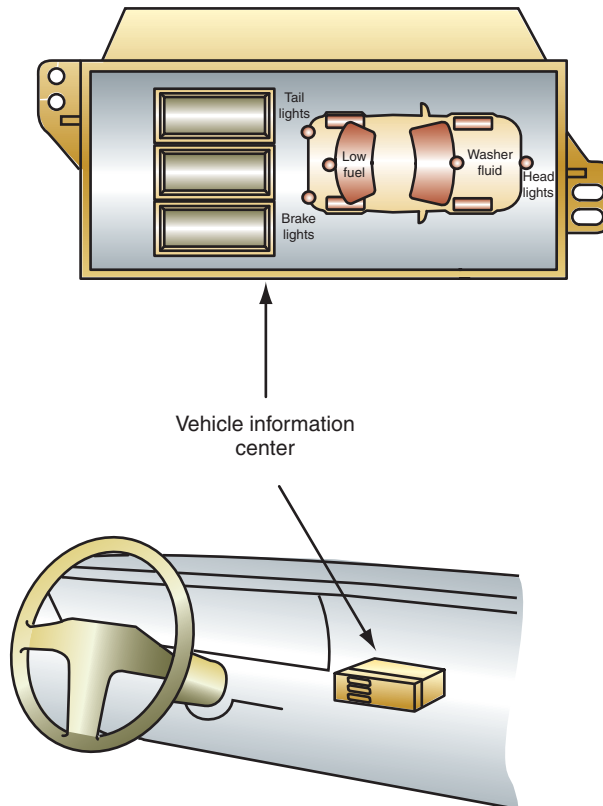
## LAMP OUTAGE INDICATORS

A common lamp outage indicator uses a translucent drawing of the vehicle (Figure 12-28). If one of the monitored systems fails or is in need of driver attention, the graphic display illuminates a light to indicate the location of the problem.

The basic lamp outage indicator system is used to monitor the stop light circuit. This system consists of a reed switch and opposing electromagnetic coils (Figure 12-29). When the ignition switch is turned to the RUN position, battery voltage is applied to the normally open reed switch. When the brake light switch is closed, current flows through the coils on the way to the stop light bulbs. If both bulbs are operating properly, the coils create opposing magnetic fields that keep the reed switch in the open position. If one of the stop light bulbs burns out, current will only flow through one of the coils, which attracts the reed switch contacts and closes them. This completes the stop light warning circuit and illuminates the warning light on the dash. The warning light will remain on as long as the stop light switch is closed.

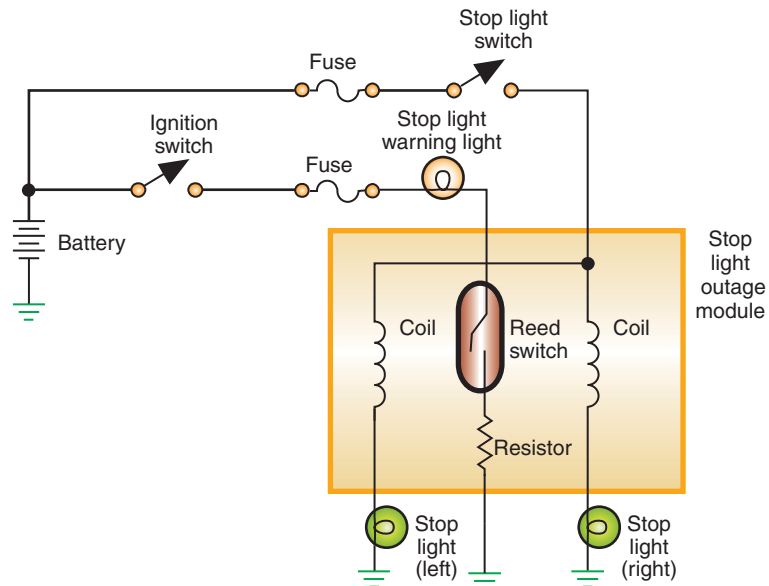
**AUTHOR’S NOTE:** Opposing magnetic fields are created because the coils are wound in opposite directions.

Some manufacturers will use a **lamp outage module** either as a stand-alone module or in conjunction with the BCM. A lamp outage module is a current-measuring sensor that



**FIGURE 12-28** Many vehicle information systems use a graphic display to indicate warning areas to the driver.

© Delmar/Cengage Learning



**FIGURE 12-29** Stop light lamp outage indicator circuit.

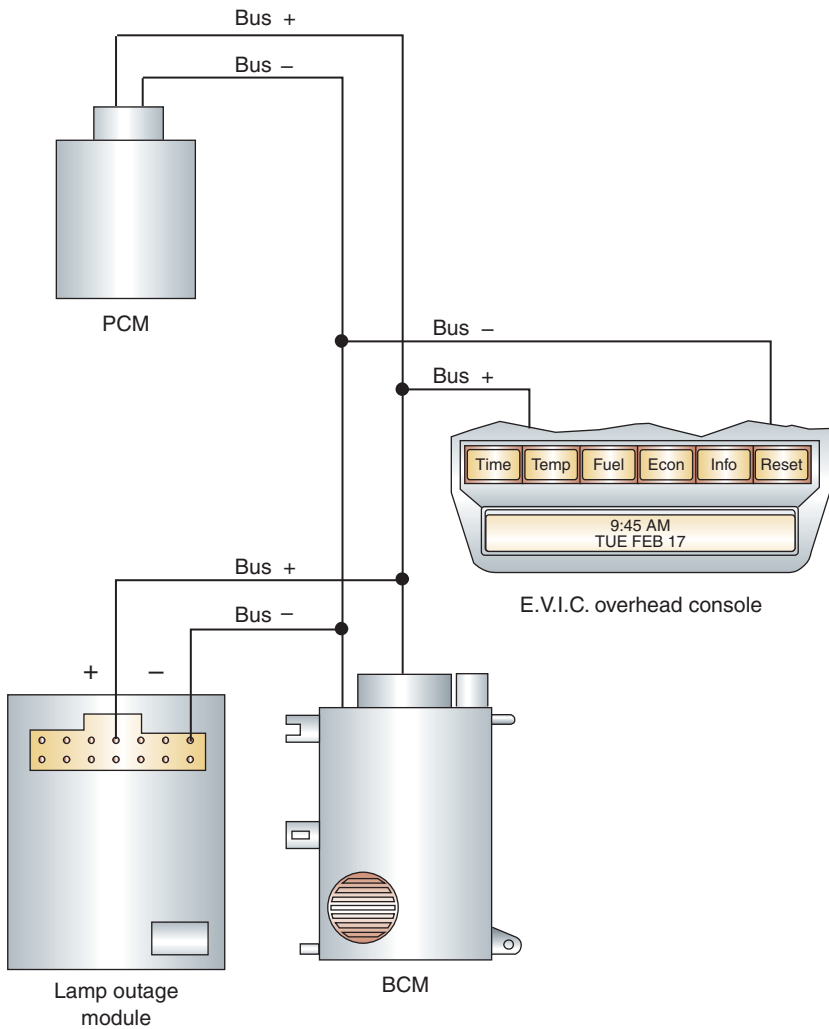
© Delmar/Cengage Learning

contains a set of resistors, wired in series with the power supply to the headlights, taillights, and stop lights. If the module is a “stand-alone” unit, it will operate the warning light directly. The module monitors the voltage drop of the resistors. If the circuits are operating properly, there is a 500 mV input signal to the module. If one of the monitored bulbs burns out, the voltage input signal drops to about 250 mV. The module completes the ground circuit to the warning light to alert the driver that a bulb has burned out. The module is capable of monitoring several different light circuits.

Many vehicles today use a computer-driven information center to keep the driver informed of the condition of monitored circuits (Figure 12-30). The vehicle information center usually receives its signals from the BCM (Figure 12-31). In this system, the lamp outage module is used to send signals to the BCM. The BCM will either illuminate a warning light,



**FIGURE 12-30** The computer-driven vehicle information center keeps the driver aware of the condition of monitored systems.



**FIGURE 12-31** The body computer can be used to receive signals from various inputs and to give signals to control the information center.



give a digital message, or activate a voice warning device to alert the driver that a light bulb is burned out.

A burned-out light bulb means there is a loss of current flow in one of the resistors of the lamp outage module. A monitoring chip in the module compares the voltage drop across the resistor. If there is no voltage drop across the resistor, there is an open in the circuit (burned-out light bulb). When the chip measures no voltage drop across the resistor, it signals the BCM, which then gives the necessary message to the vehicle information center.

**AUTHOR'S NOTE: The bulbs are monitored only when current is supplied to them.**

General Motors uses the lamp monitor module to connect the light circuits to ground (Figure 12-32). When the circuits are operating properly, the ground connection in the module causes a low-circuit voltage. Input from the lamp circuits are through two equal resistance wires. The module output to the bulbs is from the same module terminals as the inputs.

If a bulb burns out, the voltage at the lamp monitor module terminal will increase. The module will open the appropriate circuit from the BCM, signaling the BCM to send a communication to the instrument panel cluster (IPC) computer, which displays the message in the information center.

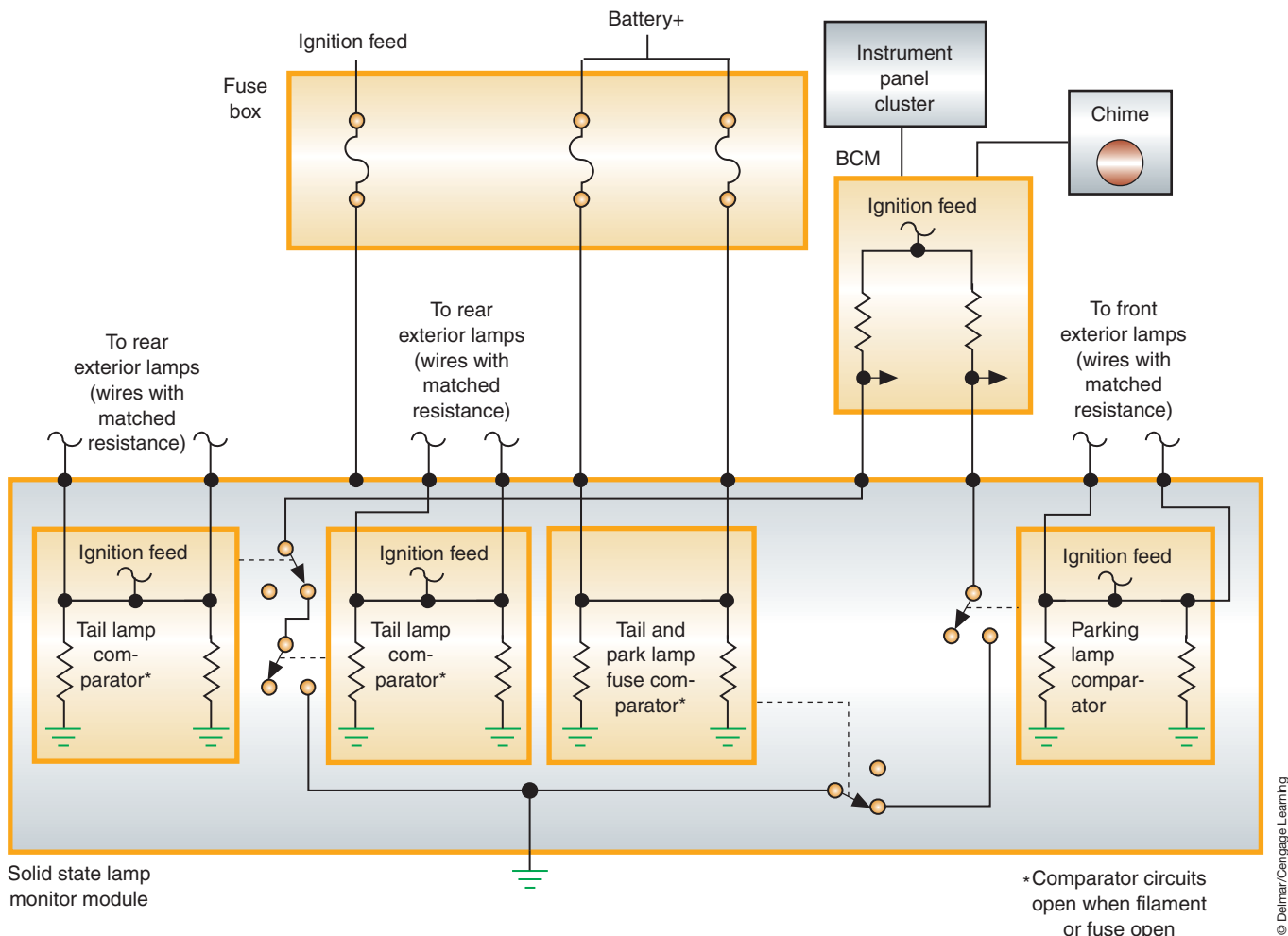


FIGURE 12-32 Lamp monitor module circuit.

Vehicles that use HSDs to control lamp illumination are also capable of detecting lamp outage. Often these systems can determine if a lamp circuit is open without the lamp system being activated. This is done by sending a small diagnostic current through the circuit. If the circuit is in tack, an expected voltage drop will occur. If the circuit is open, the voltage reading will remain high and the module will request the lamp outage indicator to come on.

## SUMMARY

---

- Some manufacturers can use the body control module (BCM) to operate the concealed headlight system.
- Usually the concealed headlight system will use a pair of relays that the BCM controls.
- Many computer-controlled headlight systems use resistive multiples headlight switches as an input.
- Computer-controlled headlight systems can use relays operated by the control module or high side drivers (HSDs) to illuminate the lamps.
- The automatic on/off with time delay has two functions: to turn on the headlights automatically when ambient light decreases to a predetermined level and to allow the headlights to remain on for a certain amount of time after the vehicle has been turned off.
- Most automatic headlight dimming systems consist of a light-sensitive photocell and amplifier unit, High–Low beam relay, sensitivity control, dimmer switch, flash-to-pass relay, and a wiring harness.
- The SmartBeam system uses a forward-facing, 5,000-pixel, digital imager camera.
- The operation of SmartBeam requires interaction with several vehicle modules, including the light rain sensor module (LRSM), the steering column module (SCM), the front control module (FCM), and the cabin compartment node (CCN).
- Decisions about headlight intensity are based on the sensed intensity of light, the light's location, and the light's movement.
- Once vehicle speed exceeds 20 mph, if the ambient light level sensed at the SmartBeam camera is 5 LUX or less, a PWM voltage is applied to the high-beam circuit by the controlling module (FCM). Within 2/2 to 5 seconds, the high beams will be at full intensity.
- A headlight leveling system (HLS) uses front lighting assemblies with a leveling actuator motor.
- The adaptive headlight system (AHS) is designed to enhance night-time safety by turning the headlight beams to follow the direction of the road as the vehicle enters a turn.
- The AHS uses sensors that measure vehicle speed, steering angle, and yaw (degree of rotation around the vertical axis). Based on this information, small electric motors turn the headlights so the beam falls on the road ahead, guiding the driver into the turn.
- The night vision system uses an infrared camera to transfer images to a display panel to enable the driver to identify and react to obstacles outside of the headlight range.
- Daytime running lamps can use a relay or module to illuminate the low- or high-beam lamps at a reduced output.
- The adaptive brake light system that selects different illumination levels or methods of display for the rear brake lights depending on conditions.
- The illuminated entry system turns on the interior lights prior to the door being opened. The system may also be capable of turning off the lights if the driver fails to shut a door when exiting.
- Instrument panel dimming is usually done by the BCM providing a pulse-width modulation to the illumination lamps or LEDs.
- Fiber optics is the transmission of light through polymethyl methacrylate plastic that keeps the light rays parallel even if there are extreme bends in the plastic.
- The lamp outage indicator alerts the driver, through an information center on the dash or console, that a light bulb has burned out.

## TERMS TO KNOW

Adaptive brake light  
Adaptive headlight system (AHS)  
Automatic headlight dimming  
Automatic on/off with time delay  
Daytime running lamps (DRL)  
Headlight leveling system (HLS)  
Illuminated entry systems  
Instrument panel dimming  
Lamp outage module  
LUX  
Photocell  
Resistive multiplex switch  
Sensitivity control  
Timer control  
“Wake-up” signal

## REVIEW QUESTIONS

---

### Short-Answer Essays

1. Describe the operation of computer-controlled concealed headlight systems.
  2. List the common components of the automatic headlight dimming system.
  3. Explain the operation of body computer-controlled instrument panel illumination dimming.
  4. What is the function of the sensitivity control in the automatic dimmer system?
  5. What is the basic operation of the illuminated entry system?
  6. Explain the operation of the SmartBeam headlight system.
  7. Describe the function of automatic headlight leveling systems.
  8. Describe the purpose and function of daytime running lamps.
  9. Explain the use and function of fiber optics.
  10. What is meant by pulse width dimming?
2. The sensitivity control used with automatic dimming sets the sensitivity at which the photocell and amplifier are \_\_\_\_\_.
  3. The photocell will have \_\_\_\_\_ resistance as the ambient light level increases.
  4. In some illuminated entry systems the \_\_\_\_\_ signals the body computer that the courtesy lights are not required.
  5. The body computer uses inputs from the \_\_\_\_\_ and \_\_\_\_\_ to determine the illumination level of the instrument panel lights.
  6. The body computer dims the illumination lamps by using a \_\_\_\_\_ signal to the panel lights.
  7. Most computer-controlled headlight systems use a \_\_\_\_\_ switch for an input.
  8. Fiber optics are commonly used as \_\_\_\_\_ lights.
  9. Lamp outage modules detect \_\_\_\_\_ in a normally operating circuit.
  10. HSDs supply \_\_\_\_\_ to the lamps.

### Fill in the Blanks

1. With body computer-controlled concealed headlights, the computer receives inputs from the \_\_\_\_\_ and \_\_\_\_\_ switches.

## MULTIPLE CHOICE

---

1. Which of the following statements is most correct?
  - A. Decreasing the sensitivity control of the automatic headlight dimming system means the headlights will switch to low beams when the approaching vehicle is farther away.
  - B. Increasing the sensitivity control of the automatic headlight dimming system means the headlights will switch to low beams when the approaching vehicle is closer.
  - C. All of the above.
  - D. None of the above.
2. All of the following statements about the SmartBeam system are true, EXCEPT:
  - A. The system uses a digital camera to determine light intensity.
  - B. The system is capable of detecting movement of oncoming light.
  - C. The system is capable of distinguishing colors.
  - D. The AHBM turns off the high-beam relay when oncoming light intensity is 10 LUX or more.

3. Computer-controlled instrument panel dimming is being discussed.  
*Technician A* says the body computer dims the illumination lamps by varying resistance through a rheostat that is wired in series to the lights.  
*Technician B* says the body computer can use inputs from the panel dimming control and photocell to determine the illumination level of the instrument panel lights on certain systems.  
 Who is correct?  
 A. A only.            C. Both A and B.  
 B. B only.            D. Neither A nor B.
4. Which statement about fiber optics is correct?  
 A. Fiber optics is the transmission of light through several plastic strands that are sheathed by a polymer.  
 B. Fiber optics is used only for exterior lighting.  
 C. Fiber optics can only be used in applications where the conduit can be laid straight.  
 D. All of the above.
5. The purpose of the headlight leveling system is to:  
 A. Reduce the need to align the light beams.  
 B. To allow the driver to raise or lower the light beams as vehicle loads change.  
 C. To allow the driver to raise or lower the light beams as the vehicle ascends and descends hills.  
 D. All of the above.
6. *Technician A* says computer-controlled headlight systems can use relays that the BCM operates.  
*Technician B* says computer-controlled headlight systems can use high side drivers to operate the lamps.  
 Who is correct?  
 A. A only.            C. Both A and B.  
 B. B only.            D. Neither A nor B.
7. In the SmartBeam system, the headlight intensity is based on which of the following:  
 A. Movement of the light.  
 B. Intensity of the light.  
 C. Location of the light.  
 D. All of the above.  
 E. None of the above.
8. *Technician A* says daytime running lamps illuminate the taillights at 25% duty cycle.  
*Technician B* says daytime running lamps can use a resistor to reduce current to the low-beam headlight.  
 Who is correct?  
 A. A only.            C. Both A and B.  
 B. B only.            D. Neither A nor B.
9. Which statement is the most correct?  
 A. Lamp outage modules can use voltage drop to determine circuit operation.  
 B. HSDs can only be used to detect opens in activated circuits.  
 C. Low-side driver controlled lamps cannot determine lamp outage conditions.  
 D. All of the above.
10. *Technician A* says the computer-controlled concealed headlight system cannot support the flash-to-pass feature.  
*Technician B* says the computer-controlled concealed headlight system may use a pair of relays to operate the doors.  
 Who is correct?  
 A. A only.            C. Both A and B.  
 B. B only.            D. Neither A nor B.

## Chapter 13

# INSTRUMENTATION AND WARNING LAMPS

### UPON COMPLETION AND REVIEW OF THIS CHAPTER, YOU SHOULD BE ABLE TO:

- Describe the operation of electromagnetic gauges, including d'Arsonval, three-coil, two-coil, and air-core.
- Describe the operation of electronic fuel, temperature, oil, and voltmeter gauges.
- Describe the operation of quartz analog instrumentation.
- Explain the function and operation of the various gauge sending units, including thermistors, piezoresistive, and mechanical variable resistors.
- Describe the purpose of speedometers and odometers.
- Describe the purpose of the tachometer.
- Describe the operating principles of the digital speedometer.
- Explain the operation of IC chip and stepper motor odometers.
- Explain the operation of various warning lamp circuits.
- Explain the operation of various audible warning systems.
- Explain the operation of body computer-controlled instrument panel illumination light dimming.

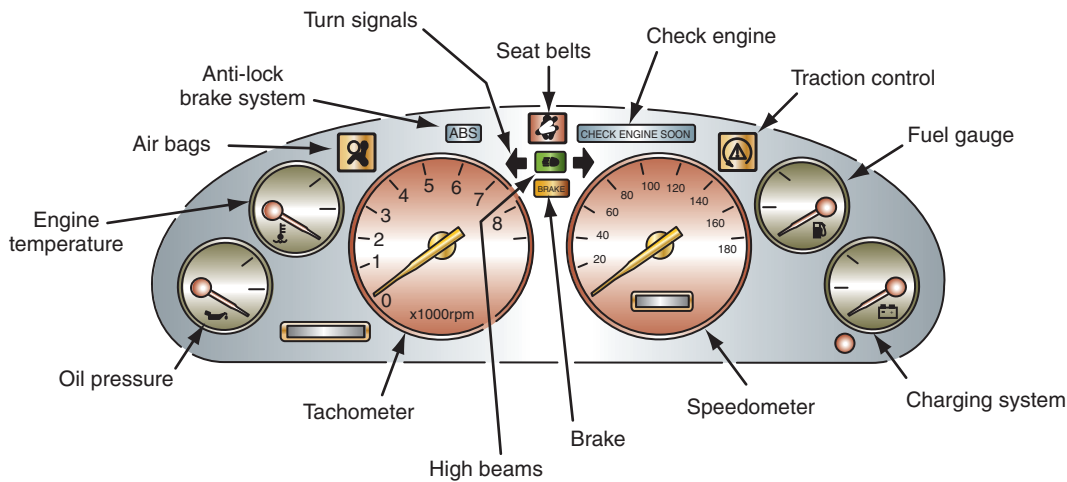
### INTRODUCTION

Instrument gauges and indicator lights monitor the various vehicle operating systems. They provide information to the driver of their correct operation (Figure 13-1). Warning devices also provide information to the driver; however, they are usually associated with an audible signal. Some vehicles use a voice module to alert the driver to certain conditions.

Early instrument cluster gauges were analog or swing needle type. Although many modern vehicles still use the analog gauge, they are now computer-driven. Computer-driven instruments are becoming increasingly popular on today's vehicle. These instruments provide far more accurate readings than their conventional analog counterparts. This chapter introduces you to the most commonly used computer-driven instrumentation systems. These systems include the speedometer, odometer, fuel, oil, tachometer, and temperature gauges.

The computer-driven instrument panel uses a microprocessor to process information from various sensors and to control the gauge display. Depending on the manufacturer, the microprocessor can be a separate computer that receives direct information from the sensors and makes the calculations, or can use the BCM to perform all functions.

In addition, there are many types of information systems used today. These systems keep the driver informed of a variety of monitored conditions, including vehicle maintenance, trip information, and navigation.



© Delmar/Cengage Learning

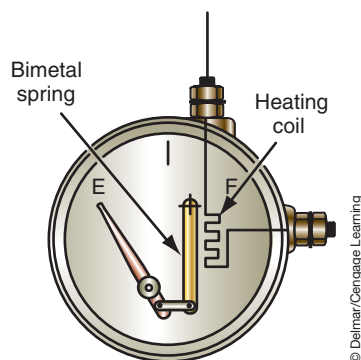
**FIGURE 13-1** Typical gauge and warning indicator layout of an instrument panel.

## ELECTROMECHANICAL GAUGES

A gauge is a device that displays the measurement of a monitored system by the use of a needle or pointer that moves along a calibrated scale. The **electromechanical** gauge acts as an ammeter since the gauge reading changes with variations in resistance. The gauge is called an electromechanical device because it is operated electrically, but its movement is mechanical. There are two basic types of electromechanical gauges: the bimetallic gauge and the electromagnetic gauge. Conventional analog instrument clusters that used these types of gauges had a direct connection to the sending unit. The resistance of the sending unit determined the location of the needle on the gauge face. A short study of the different types of gauges is provided to give a foundation to the study of computer-driven gauges.

Bimetallic gauges are not used in today's automobiles. These gauges (or thermoelectric gauges) were simple dial and needle indicators that transformed the heating effect of electricity into mechanical movement. The construction of the bimetallic gauge featured an indicating needle linked to the free arm of a U-shaped bimetallic strip (Figure 13-2). The free arm had a heater coil connected to the gauge terminal posts. When current flowed through the heater coil, it heated the bimetallic arm and caused the arm to bend and move the needle across the gauge dial. The amount the bimetallic strip bent is proportional to the heat produced in the heater coil; the greater the heat created, the more the needle would move. Current flow was controlled by the changing resistance of a sending unit.

**Electromagnetic gauges** produce needle movement by magnetic forces instead of heat. There are four types of electromagnetic gauges: the d'Arsonval, the three-coil, the two-coil, and the air-core.



© Delmar/Cengage Learning

**FIGURE 13-2** Bimetallic gauge construction.

**Shop Manual**  
Chapter 13, page 539



The **d'Arsonval gauge** uses the interaction of a permanent magnet and an electromagnet, and the total field effect to cause needle movement. The d'Arsonval gauge consists of a permanent horseshoe-type magnet that surrounds a moveable electromagnet (armature) that is attached to a needle (Figure 13-3). When current flows through the armature, it becomes an electromagnet and is repelled by the permanent magnet. When current flow through the armature is low, the strength of the electromagnet is weak and needle movement is small. When the current flow is increased, the magnetic field created in the armature is increased and needle movement is greater. The armature has a small spring attached to it to return the needle to zero when current is not applied to the armature.

The **three-coil gauge** is also known as a magnetic bobbin gauge.

The **three-coil gauge** uses the interaction of three electromagnets and the total field effect upon a permanent magnet to cause needle movement. The three-coil gauge consists of a permanent magnet with a needle attached to it. The permanent magnet is surrounded by three electromagnets. There may also be a quantity of silicone dampening fluid to restrict needle movement due to vehicle movement. The current flow controlled by the resistance from the variable resistor-type sending unit determines the magnetic strength of the coils.

The three coils of fine wire are wound on a square plastic frame. The needle shaft is supported by a bearing sleeve extending from the frame. The needle shaft connects the pointer.

The three coils are the **bucking coil**, the **low-reading coil**, and the **high-reading coil** (Figure 13-4). The bucking coil produces a magnetic field that bucks or opposes the low-reading coil. The low-reading coil and the bucking coil are wound together, but in opposite directions. The high-reading coil is positioned at a 90° angle to the low-reading and bucking coils. To compensate for production tolerances in the coils, a selective shunt resistor is attached to the back of the gauge housing. This selective resistor bypasses a certain amount of current past the coils.

When voltage is applied to the gauge, there are two paths in which the current can flow. One path is through the low-reading coil and through the sending unit to ground (Figure 13-5). The second path is through the low-reading coil to the bucking coil and the high-reading coil to ground (Figure 13-6). The amount of resistance that the sending unit has determines the path. If there is less resistance to ground through the sending unit than through the bucking and high-reading coils, most of the current will take the path through the sending unit. If the resistance through the sending unit is greater than the resistance through the coils, very little current will flow through the sending unit.

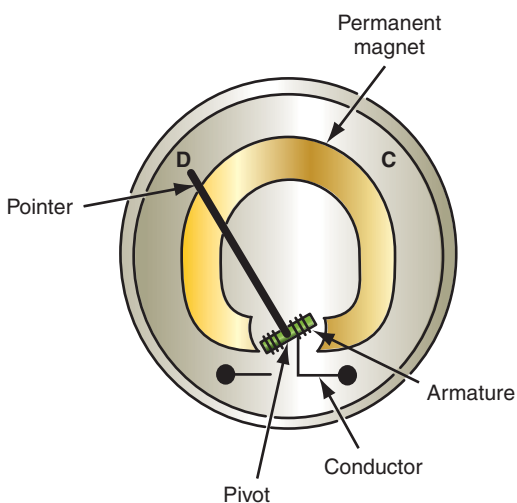


FIGURE 13-3 d'Arsonval gauge needle movement.

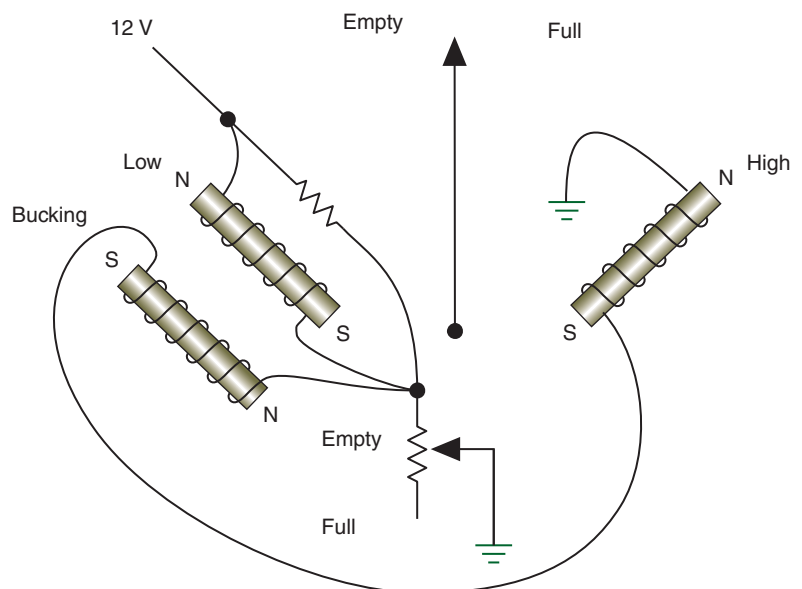
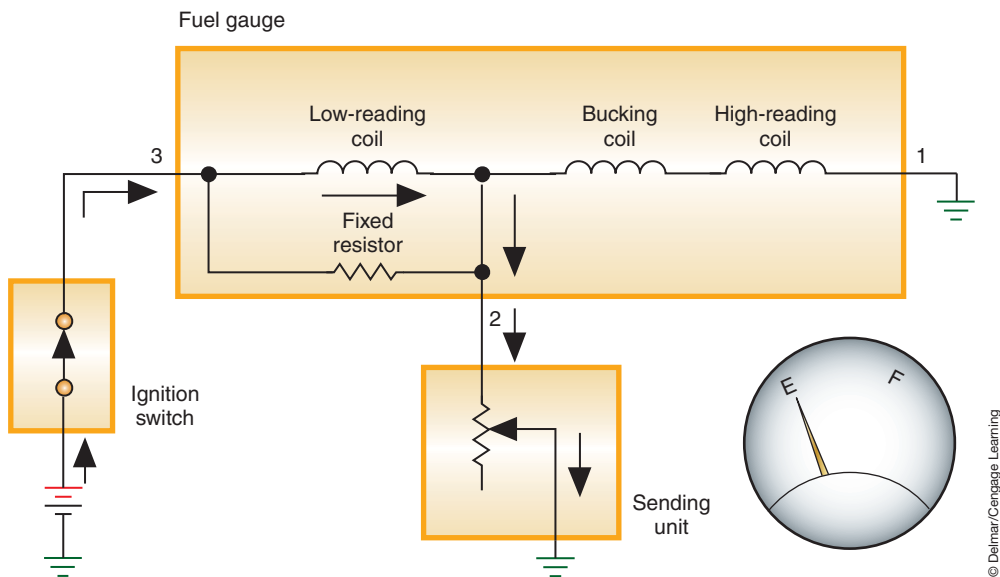
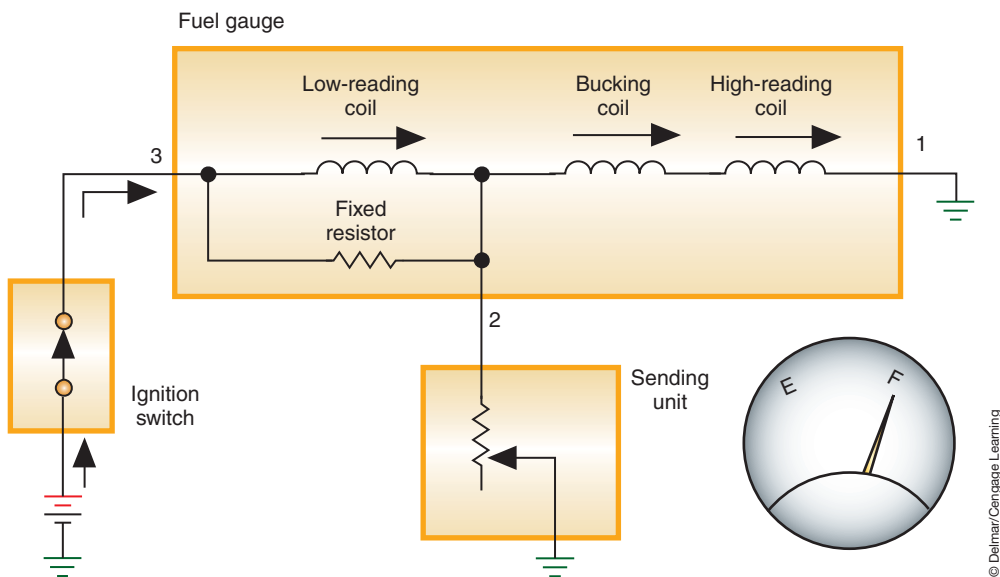


FIGURE 13-4 Three-coil gauge circuit.



**FIGURE 13-5** With sending unit resistance low, the needle is attracted to the low-reading coil.



**FIGURE 13-6** With sending unit resistance high, the needle is attracted to the high-reading coil.

When sending unit resistance is low, more current flows through the low-reading coil than through the bucking and high-reading coils. This causes the needle to be attracted to the left, and the gauge reads toward zero. When sending unit resistance is high, very little current will flow through the sending unit. The current now flows through the three coils. The magnetic field created by the bucking coil cancels the magnetic field of the low-reading coil. The high-reading coil's magnetic field then attracts the needle and it swings toward maximum.

At an intermediate sending unit resistance value, the current can flow through both paths. If resistance was equal in the two paths, the needle would point at the midrange. As the magnetic field(s) changes, as the result of resistance change in the sending unit, the needle will swing toward the more powerful magnetic field.

The **two-coil gauge** uses the interaction of two electromagnets and the total field effect on an armature to cause needle movement. There are different designs of the two-coil

gauge, depending upon the gauge application. For example, in a coolant temperature gauge (Figure 13-7), both coils receive battery voltage. One of the coils is grounded directly, while the other is grounded through the sender unit. As the resistance in the sender unit varies, as a result of temperature changes, the current flow through that coil changes. The two magnetic fields have different strengths, depending upon the amount of current flow through the sender unit. A two-coil gauge that is constructed to be used as a fuel gauge will have the E coil receiving battery voltage (Figure 13-8). At the end of the coil, the voltage is divided. One path is through the F coil to ground, while the other is through the sender unit to ground. The stronger the current flow through a coil, the more the needle will move toward that coil.

The most common style of gauge used today is the **air-core gauge**. The air-core gauge works on the same principle as the two-coil by using the interaction of two electromagnets and the total field effect upon a permanent magnet to cause needle movement. This gauge has the pointer connected to a permanent magnet (Figure 13-9). Two windings are placed at different angles, one wound around the other. There is no core inside of the windings. Instead, the permanent magnet is placed inside the windings. The magnet aligns itself to a resultant field, in the field windings, according to the resistance of the sender unit. The sender unit resistance varies the strength of the field winding, which opposes the strength of the reference winding. The strength of the electromagnetic field depends upon the resistance in the sending unit.

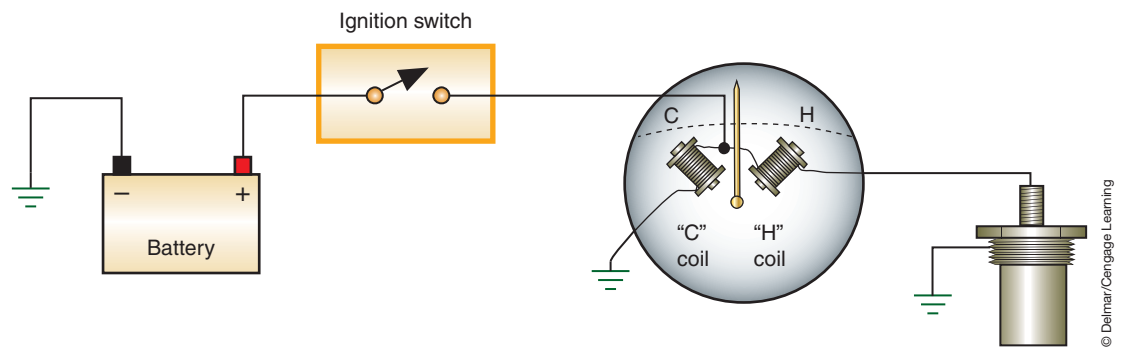


FIGURE 13-7 A two-coil temperature gauge.

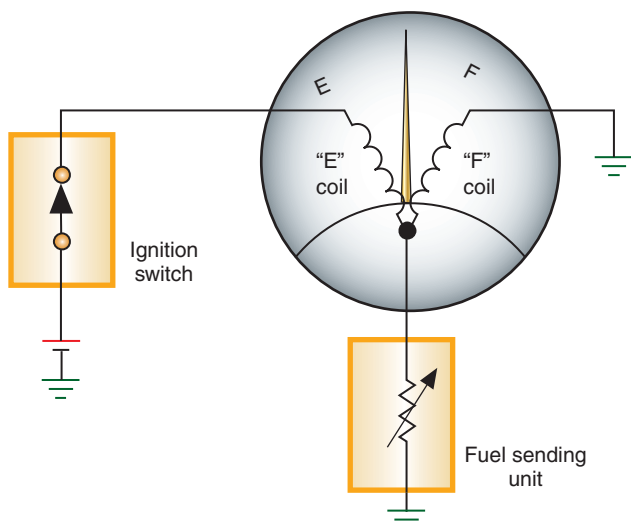


FIGURE 13-8 A two-coil fuel gauge.

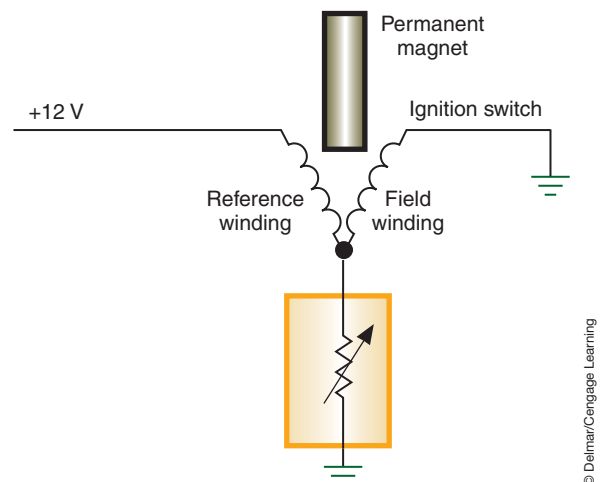


FIGURE 13-9 Air-core fuel gauge circuit.

## QUARTZ ANALOG INSTRUMENTATION

Computer-driven quartz swing needle displays are similar in design to the air-core electromagnetic gauges used in conventional analog instrument panels (Figure 13-10). Any, or all, of the gauges in the instrument cluster may be this type. We will look at the **speedometer** as an example of operation. The speedometer is used to indicate the speed of the vehicle.

Conventional speedometers used a cable that was connected to the output shaft of the transmission (or transfer case if four-wheel drive). The rotation of the output shaft caused the speedometer cable to rotate within its housing and then transferred to the speedometer assembly. This system relied on a rotating permanent magnet that produced a rotating magnetic field around a drum. The rotating magnetic field generated circulating eddy currents in the drum that produced a small magnetic field that interacted with the field of the rotating magnet. This interaction of the two magnetic fields pulled the drum and needle around with the rotating magnet. It is not hard to see that this system would not be extremely accurate. Today's vehicles use sensors and computer logic to display vehicle speed.

In many quartz analog speedometer gauge systems, a permanent magnet generator sensor is installed in the transaxle, transmission, or differential. As the PM generator is rotated, it causes a small AC voltage to be induced in its coil. This AC voltage signal is sent to a **buffer circuit** that changes the AC voltage from the PM generator into a digitalized signal (Figure 13-11). The signal is then sent to the processing unit (Figure 13-12). The signal is passed to a quartz clock circuit, a gain selector circuit, and a driver circuit. The driver circuit sends voltage pulses to the coils of the gauge; the coils operate like conventional air-core gauges to move the needle.



FIGURE 13-10 Electronically controlled swing needle instrumentation.

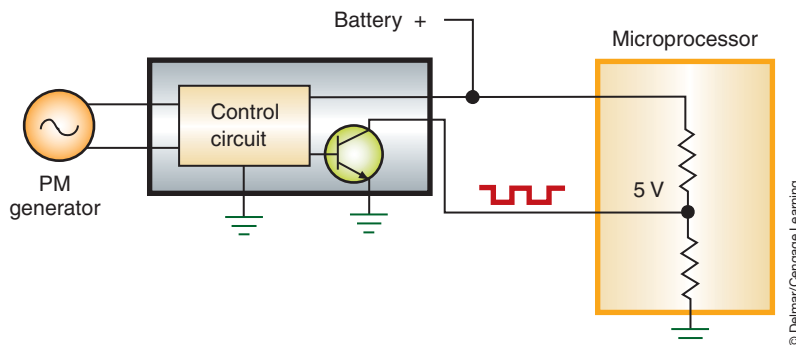


FIGURE 13-11 A buffer circuit.

**Shop Manual**  
Chapter 13, pages  
536, 543

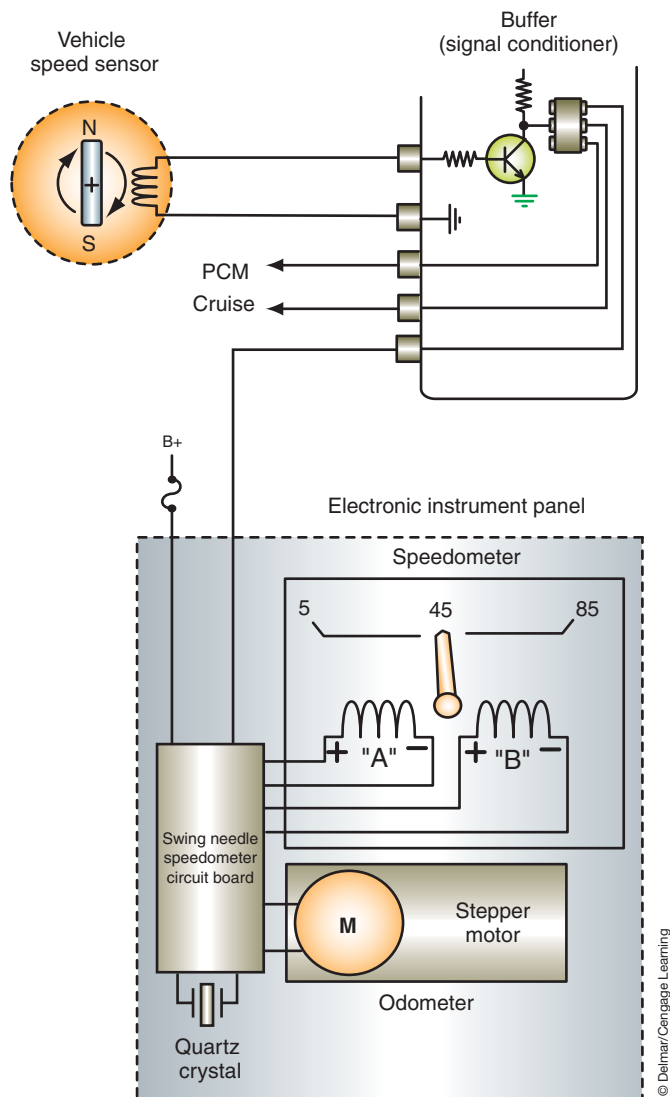
**Shop Manual**  
Chapter 13, page 534

**Shop Manual**  
Chapter 13, page 537



### A BIT OF HISTORY

One of the early styles of speedometers used a regulated amount of air pressure to turn a speed dial. The air pressure was generated in a chamber containing two intermeshing gears. The gears were driven by a flexible shaft that was connected to a front wheel or the driveshaft. The air was applied against a vane inside the speed dial. The amount of air applied was proportional to the speed of the vehicle.



**FIGURE 13-12** Quartz swing needle speedometer schematic. The “A” coil is connected to system voltage and the “B” coil receives a voltage that is proportional to input frequency. The magnetic armature reacts to the changing magnetic fields.

Often the sensor used to determine vehicle speed has multiple purposes. In this case, the signal being generated may not be an accurate representation of vehicle speed because it comes before the final drive unit. The control module may need to do additional calculations to make the speedometer accurate. For example, Chrysler vehicles equipped with the 41TE or 42LE electronic shift transaxles use an output speed sensor that generates an AC signal from a 24-tooth tone wheel on the rear planetary unit. This signal is sent to the transmission control module (TCM). The TCM will apply **pinion factor** to the hertz count of the speed sensor signal to calculate vehicle speed. Pinion factor is a calculation using the final drive ratio and the tire circumference to obtain accurate vehicle speed signals. The TCM then transmits this information to the PCM at a set rate of 8,000 pulses per mile by pulsing the dedicated circuit. The PCM will then send the vehicle speed signal over the data bus circuit to all modules that require it.

In some applications, the mechanical instrument cluster (MIC) receives the vehicle speed message from the BCM instead of receiving it directly from the PCM. The MIC then sets the needle to read the vehicle speed. Even though the MIC is on the bus system, it does not respond to the vehicle speed signal the PCM sends. It is programmed to accept messages only from the BCM.

Pinion factor information is set into the TCM at the factory. If the TCM is replaced in the field, the scan tool must be used to program the tire size used on the vehicle. In some systems, the gear ratio also has to be programmed. If the pinion factor is not programmed into the TCM, the speedometer and cruise control systems will not function.

Some manufacturers will use the wheel speed sensors from the antilock brake system (ABS) to determine vehicle speed. Usually the two front or the two rear sensor inputs are averaged. The ABS module then determines vehicle speed and broadcasts the information on the data bus.

The other air-core gauges (temperature, fuel level, and so on) work as described earlier, with conventional instrument clusters. The difference is the sending unit input goes to a module. The current flow through the gauge coils is controlled by the module, based on the sending unit resistance.

## GAUGE SENDING UNITS

The **sending unit** is the sensor for the gauge. It is a variable resistor that changes resistance values with changes in the monitored conditions. There are three types of sending units that are associated with the gauges just described: (1) a **thermistor**, (2) a **piezoresistive sensor**, and (3) a mechanical variable resistor. These same types of sending units can also be used for computer-driven instrument clusters.

In the conventional coolant temperature sensing circuit, current is sent from the gauge unit into the top terminal of the sending unit, through the variable resistor (thermistor), and to the engine block (ground). The resistance value of the thermistor changes in proportion to coolant temperature (Figure 13-13). As the temperature rises, the resistance decreases and the current flow through the gauge increases. As the coolant temperature lowers, the resistance value increases and the current flow decreases.

In a computer-driven gauge or digital display, the control module will send a 5-volt reference voltage through a pull-up resistor and then to the temperature sensor. This type of circuit was discussed in Chapter 10. As the resistance changes, the voltage dropped over the pull-up resistor changes and the voltmeter reading will indicate the engine temperature. The PCM will send the temperature information over the data bus to the instrument cluster (or BCM). The module will then send a current to the gauge coils to move the pointer to the correct temperature reading.

The piezoresistive sensor sending unit is threaded into the oil delivery passage of the engine and the pressure that is exerted by the oil causes the flexible diaphragm to move (Figure 13-14). The diaphragm movement is transferred to a contact arm that slides along the resistor. The position of the sliding contacts on the arm in relation to the resistance coil determines the resistance value, and the amount of current flow through the gauge to ground.

Another style is a transducer that operates much like a Wheatstone bridge MAP sensor. The function of the gauge is the same as that just discussed for the computer-driven temperature gauge, based on data bus messages from the PCM.

Some computer-driven instrument clusters have an oil gauge but do not use a sensor. These systems use an oil pressure switch. When oil pressure is greater than 6 psi (41 kPa), the switch opens the sense circuit. This will pull the sense voltage high. The gauge will display an oil pressure that is based on a calculated value determined by engine run time, engine temperature, engine load value, and ambient temperature. If the oil pressure drops below 6 psi (41 kPa), the switch closes the circuit to ground, pulling the sense voltage low. The instrument cluster gauge will now read 0. As long as the switch is open, the gauge will indicate normal oil pressure.

A fuel level sending unit is an example of a mechanical variable resistor (Figure 13-15). The sending unit is located in the fuel tank and has a float that is connected to the wiper of a

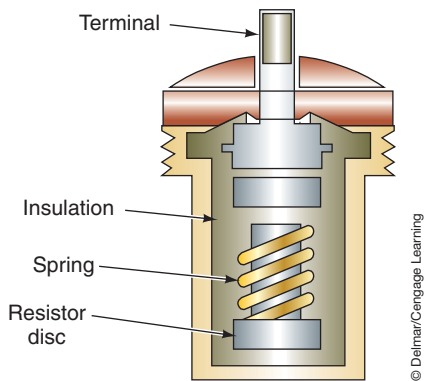
### Shop Manual

Chapter 13, page 544

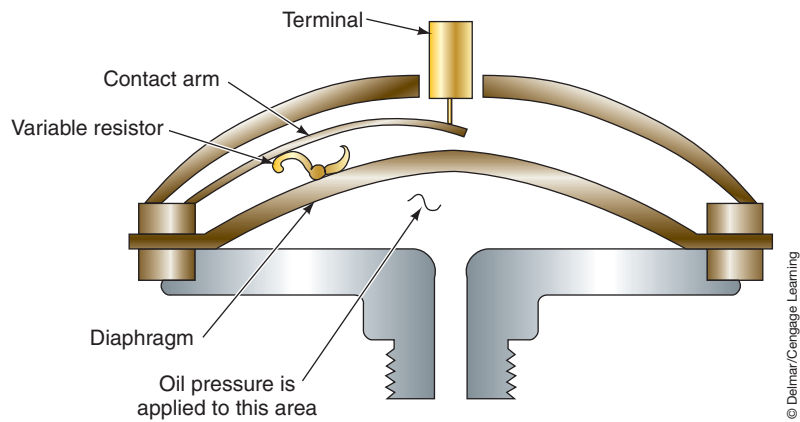
The **thermistor** is a resistor whose resistance changes in relation to changes in temperature; it is often used as a coolant temperature sensor.

A **piezoresistive** sensor is sensitive to pressure changes. The most common use of this type of sensor is to measure the engine oil pressure.

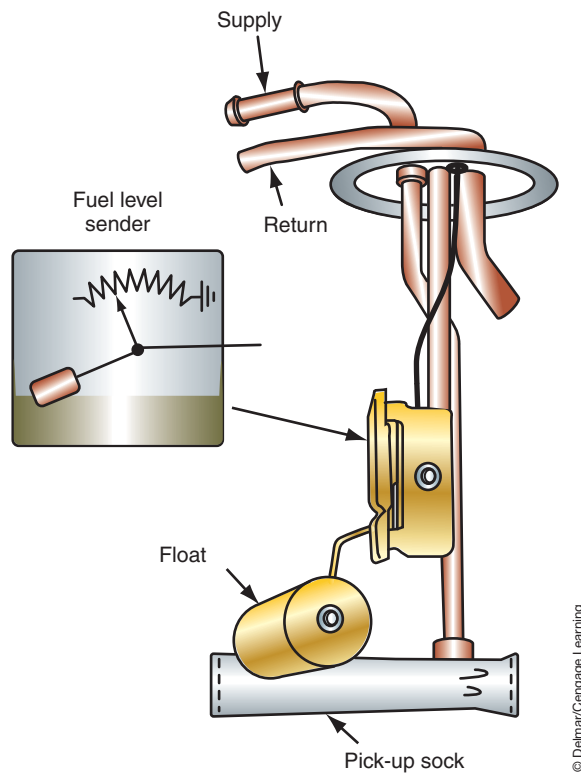




**FIGURE 13-13** A thermistor used to sense engine temperature.



**FIGURE 13-14** Piezoresistive sensor used for measuring engine oil pressure.



**FIGURE 13-15** Fuel gauge sending unit.

variable resistor. The floating arm rises and falls with the difference in fluid level. This movement of the float is transferred to the sliding contacts. The position of the sliding contacts on the resistor determines the resistor value.

## DIGITAL INSTRUMENTATION

Digital instrumentation is far more precise than conventional analog gauges. Analog gauges display an average of the readings received from the sensor; a digital display will present exact readings. In some systems, the information to the gauge is updated as often as 16 times per second.

**Digital instrument clusters** use digital and linear displays to notify the driver of monitored system conditions (Figure 13-16). Most digital instrument clusters provide for display in English or metric values. Also, many gauges are a part of a multigauge system. Drivers



© Delmar/Cengage Learning

FIGURE 13-16 Digital instrument cluster.

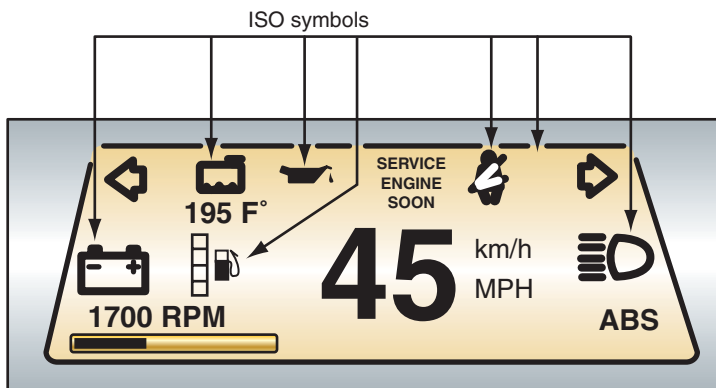
select which gauges they wish to have displayed. Most of these systems will automatically display the gauge to indicate a potentially dangerous situation. For example, if the driver has chosen the oil pressure gauge to be displayed and the engine temperature increases above set limits, the temperature gauge will automatically be displayed to warn the driver. A warning light and/or a chime will also activate to get the driver's attention.

Most electronic instrument panels have self-diagnostic capabilities. The tests are initiated through a scan tool or by pushing selected buttons on the instrument panel. The instrument panel cluster also initiates a self-test every time the ignition switch is turned to ACC or RUN. Usually the entire dash is illuminated and every segment of the display is lighted. **International Standards Organization (ISO)** symbols are used to represent the gauge function (Figure 13-17). These symbols will usually flash during this test. At the completion of the test, all gauges will display current readings. A code is displayed to alert the driver if a fault is found.

## Speedometers

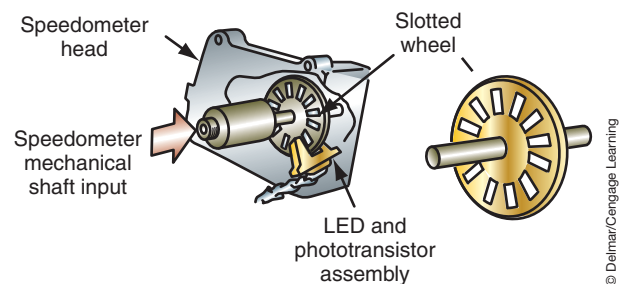
Ford, GM, and Toyota have used optical vehicle speed sensors. The Ford and Toyota optical sensors are operated from the conventional speedometer cable. The cable rotates a slotted wheel between an LED and a phototransistor (Figure 13-18). As the slots in the wheel break the light, the transistor conducts an electronic pulse signal to the speedometer. An integrated circuit rectifies the analog input signal from the optical sensor and counts the pulses per second. The value is calculated into mph and displayed in the digital readout. The display is updated every 1/2 second. If the driver selected the readout to be in kilometers per hour, the

**Shop Manual**  
Chapter 13, pages  
536, 538



© Delmar/Cengage Learning

FIGURE 13-17 A few of the ISO symbols used to identify the gauge.



© Delmar/Cengage Learning

FIGURE 13-18 Optical speed sensor.

The electronic speedometer receives voltage signals from the vehicle speed sensor (VSS). This sensor can be a PM generator, Hall-effect switch, or an optical sensor.

### Shop Manual

Chapter 13, page 529

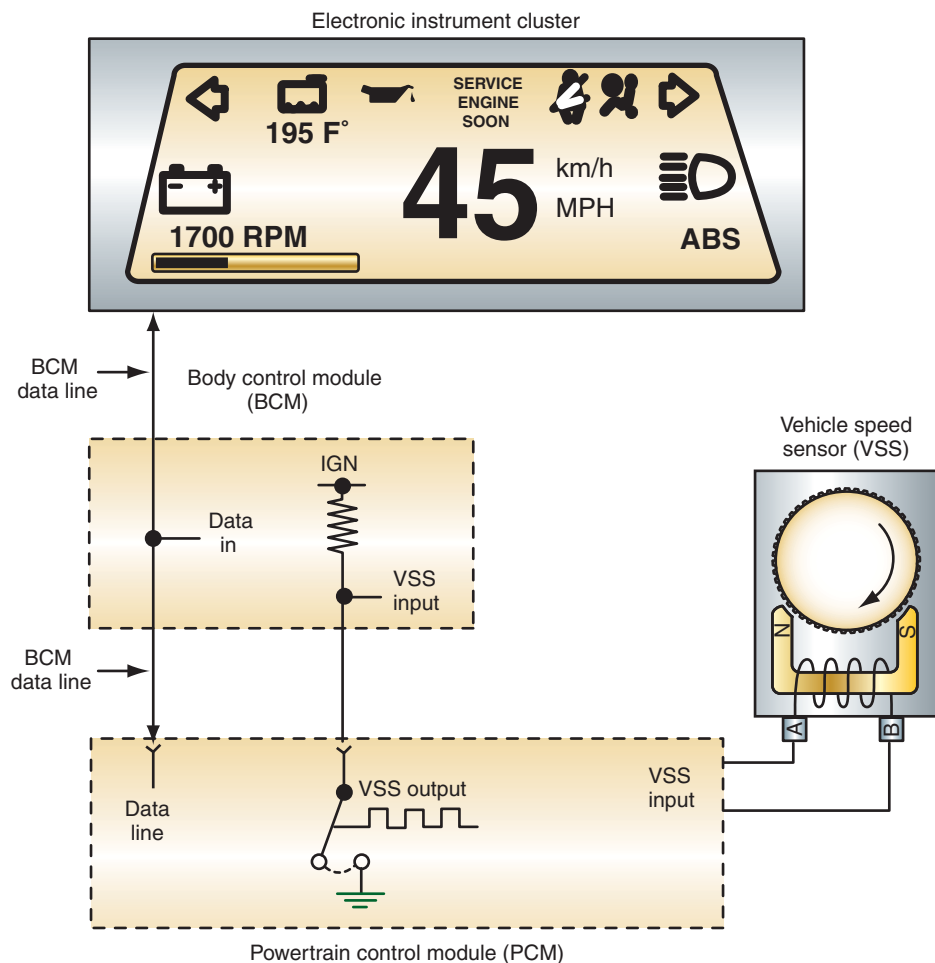
computer makes an additional calculation to convert the readout. These systems may use a conventional gear-driven odometer.

The early style of GM speed sensor also operated from the conventional speedometer cable. The LED directs its light onto the back of the speedometer cup. The cup is painted black and the drive magnet has a reflective surface applied to it. As the drive magnet rotates in front of the LED, its light is reflected back to a phototransistor. A small voltage is created every time the phototransistor is hit with the reflective light.

The illustration (Figure 13-19) is a schematic of an instrument panel cluster that uses a PM generator for the VSS. As the PM generator is rotated, it causes a small AC voltage to be induced in its coil. This AC voltage signal is sent to the powertrain control module (PCM) and is shared with the BCM. The signal is rectified into a digital signal that is used to control the output to the instrument panel cluster (IPC) module. The BCM calculates the vehicle speed and provides this information to the IPC module through the serial data link. The IPC module turns on the proper display.

The microprocessor will initiate a self-check of the electronic instrument cluster any time the ignition switch is placed in the ACC or RUN position. The self-check usually runs for about 3 seconds. The most common sequence for the self-check is as follows:

1. All display segments are illuminated.
2. All displays go blank.
3. 0 mph or 0 km/h is displayed.



**FIGURE 13-19** The instrument panel cluster module receives its instructions from the BCM, which shares the signals from the VSS with the ECM.

© Delmar/Cengage Learning

In addition to the methods of sensing speed mentioned earlier, Hall-effect switches are also used. The sensor is attached to a gear-driven wheel that rotates a trigger wheel. The gear is determined by tire size and the final drive gear ratio of the vehicle. As the trigger wheel rotates, it will cause the Hall-effect switch to change voltages to high and low at a set amount each revolution. The amount of switches per revolution remains constant regardless of vehicle speed. Once the control module receives a programmed number of switches (8,000 for example), it knows it has traveled one mile.

## Odometers

The **odometer** is a counter that uses the speedometer inputs to indicate the total miles accumulated on the vehicle. Many vehicles also have a second odometer that can be reset to zero; this is referred to as a trip odometer.

Early odometers were driven by the speedometer cable through a worm gear. If the speedometer uses an optical sensor, the odometer may be of conventional design. Two other types of odometer are used with electronic displays: the electromechanical type with a stepper motor and the electronic design using an IC chip.

**Stepper Motor.** The electromechanical odometer uses a DC stepper motor that receives control signals from the speedometer circuit (Figure 13-20). The digital signal impulses from the speedometer are processed through a circuit that will halve the signal. The stepper motor receives one-half of the VSS signals sent to the instrument panel cluster. As the stepper motor is activated, the rollers are rotated to accurately display accumulated mileage.

General Motors controls the stepper motor through the same impulses that are sent to the speedometer. The stepper motor uses these signals to turn the odometer drive IC on and off. An **H-gate** arrangement of four transistors is used to drive the stepper motor by alternately activating a pair of its coils (Figure 13-21). The H-gate is constantly

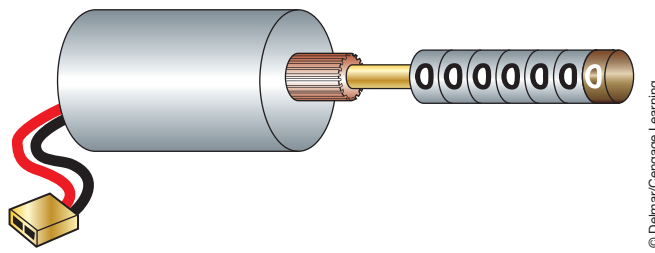


FIGURE 13-20 A stepper motor is used to rotate the odometer dial.

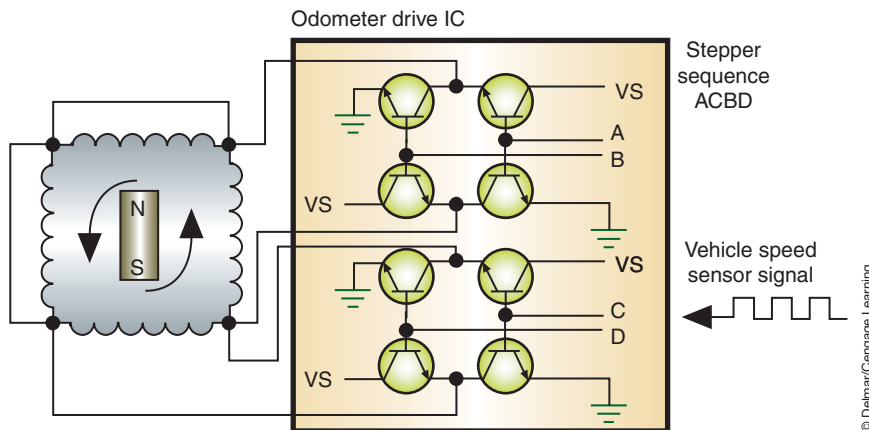


FIGURE 13-21 The H-gate energizes two coils at a time and constantly reverses system polarity.

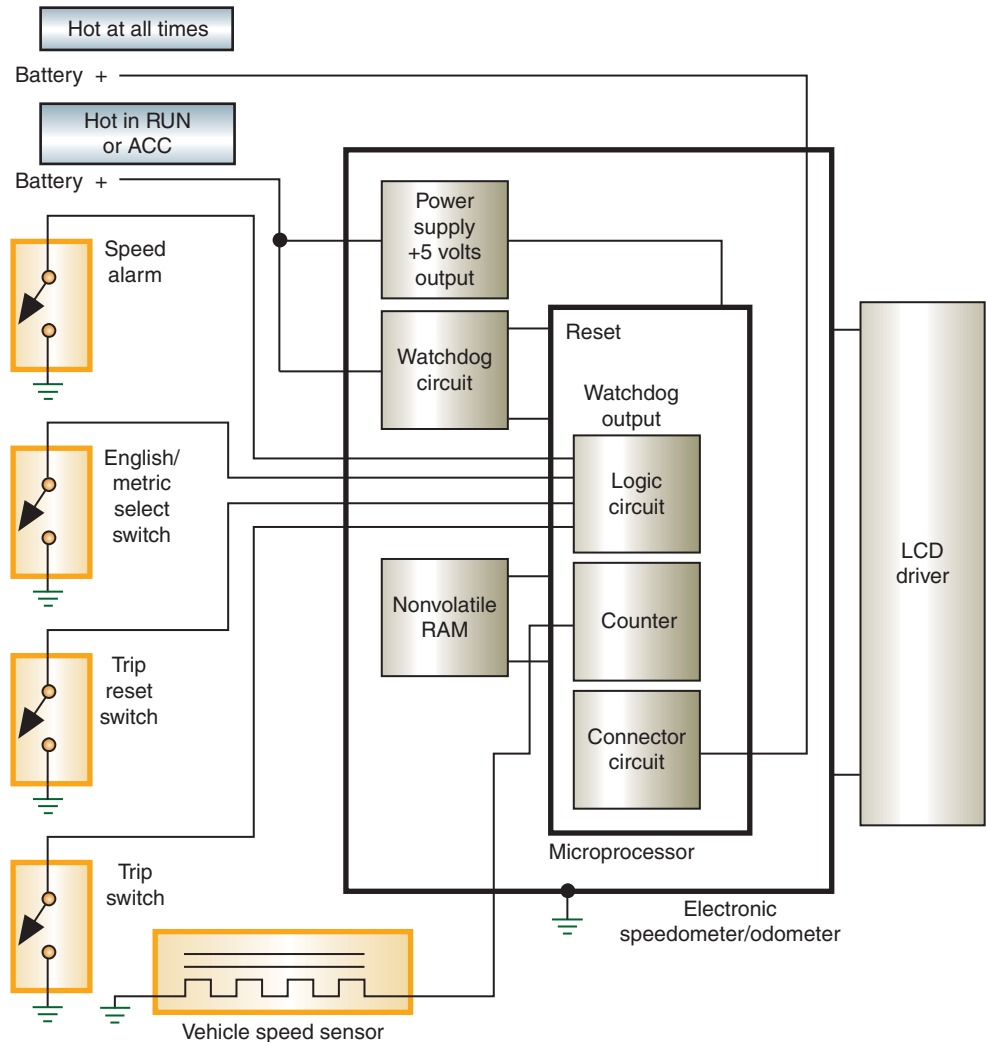
reversing system polarity, causing the permanent magnet poles to rotate in the same direction.

In most systems, distance is updated to the RAM every 10 miles and whenever the ignition switch is turned off.

**IC Chip.** The IC chip–type odometer uses a nonvolatile RAM that receives distance information from the speedometer circuit or from the engine controller. The controller can update the odometer display every 1/2 second.

Many instrument panel clusters cannot display both trip mileage and odometer readings at the same time. Drivers must select which function they wish to have displayed (Figure 13-22). By depressing the trip reset button, a ground is applied as an input to the microprocessor. The microprocessor clears the trip odometer readings from memory and returns the display to zero. The trip odometer will continue to store trip mileage even if this function is not selected for display.

If the IC chip fails, some manufacturers provide for replacement of the chip. Depending on the manufacturer, the new chip may be programmed to display the last odometer reading. Most replacement chips will display an X, S, or \* to indicate the odometer has been changed. If the odometer IC chip cannot be programmed to display correct accumulated mileage, a door sticker must be installed to indicate the odometer has been replaced.



**FIGURE 13-22** The trip reset button provides a ground signal to the logic circuit, which is programmed to erase the trip odometer memory while retaining total accumulated mileage in the odometer.

**AUTHOR'S NOTE:** Federal Motor Vehicle Safety Standards require the odometer be capable of storing up to 500,000 miles in nonvolatile memory. Most odometer readouts are up to 199,999.9 miles.

If an error occurs in the odometer circuit, the display will change to notify the driver. The form of error message differs among manufacturers. In some systems, the word "ERROR" is displayed, while others may use dashed lines.

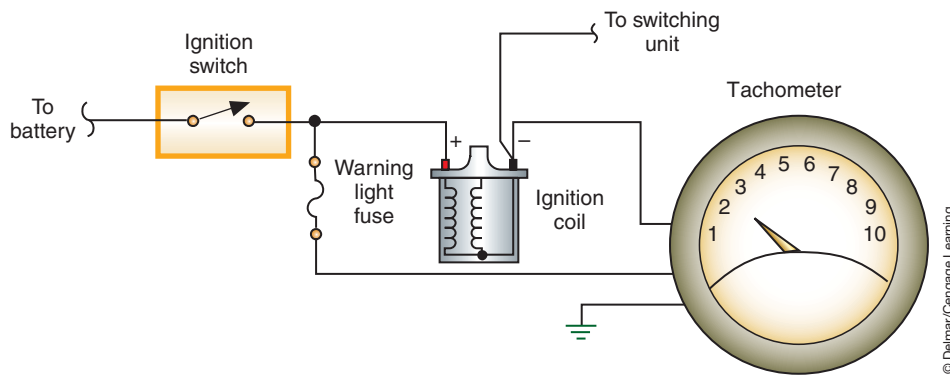
Federal and state laws prohibit tampering with the correct mileage as indicated on the odometer. If the odometer must be replaced, it must be set to the reading of the original odometer, or a door sticker must be installed indicating the reading of the odometer when it was replaced.

## Tachometers

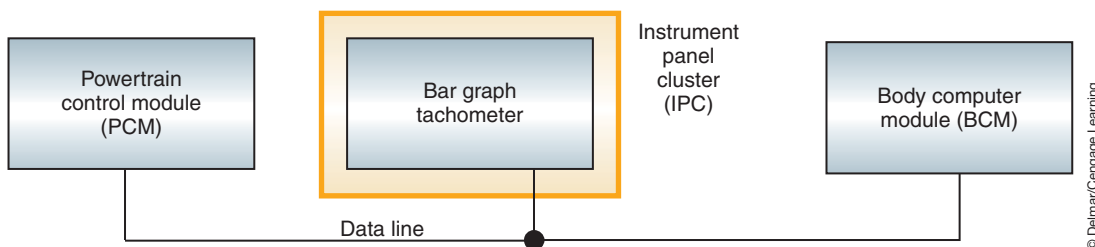
A **tachometer** is an instrument that measures the speed of the engine in revolutions per minute (rpm). The electric tachometer receives voltage pulses from the ignition system, usually the ignition coil (Figure 13-23). The tachometer signal is picked up from the negative (-) side of the coil as the switching unit opens the primary circuit. Each of the voltage pulses represents the generation of one spark at the spark plug. The rate of spark plug firing is in direct relationship to the speed of the engine. A circuit within the tachometer converts the ignition pulse signal into a varying voltage. The voltage is applied to a voltmeter that serves as the engine speed indicator.

The digital tachometer can be a separate function that is displayed at all times, or a part of a multigauge display. The digital tachometer receives its voltage signals from the ignition module or PCM via the bus network and displays the readout in a bar graph (Figure 13-24). The multigauge system has a built-in power supply that provides a 5-volt

**Shop Manual**  
Chapter 13, page 539



**FIGURE 13-23** Electrical tachometer wired into the ignition system.



**FIGURE 13-24** The IPC "listens in" on the communications between the PCM and the BCM to gather information on engine speed.



reference signal to the other monitored systems for the gauge. Also, the gauge has a **watch-dog circuit** incorporated in it. The power on/off watchdog circuit supplies a reset voltage to the microprocessor in the event that pulsating output signals from the microprocessor are interrupted.

## Shop Manual

Chapter 13, page 544

### Electronic Fuel Gauges

Most digital fuel gauges use a fuel level sender that decreases resistance value as the fuel level decreases. This resistance value is converted to voltage values by the microprocessor. A voltage-controlled **oscillator** changes the signal into a frequency signal. The microprocessor counts the cycles and sends the appropriate signal to operate the digital display (Figure 13-25).

An F is displayed when the tank is full and an E is displayed when less than 1 gallon is remaining in the tank. Other warning signals include incandescent lamps, a symbol on the dash, or flashing of the fuel ISO symbol. If the warning is displayed by a bulb, usually a switch is located in the sending unit that closes the circuit. The microprocessor usually controls flashing digital displays.

The bar graph-style gauge uses segments that represent the amount of fuel remaining in the tank (Figure 13-26). The segments divide the tank into equal levels. The display will also include the F, 1/2, and E symbols along with the ISO fuel symbol. A warning to the driver is displayed when only one bar is lit. The gauge will also alert the driver to problems in the circuit. A common method of indicating an open or short is to flash the F, 1/2, and E symbols while the gauge reads empty.

### Other Digital Gauges

Most of the gauges used to display temperature, oil pressure, and charging voltage are of bar graph design. Another popular method is to use a floating pointer (Figure 13-27).

The temperature gauge will usually receive its input from an NTC thermistor. When the engine is cold, the resistance value of the thermistor is high, resulting in a high-voltage input

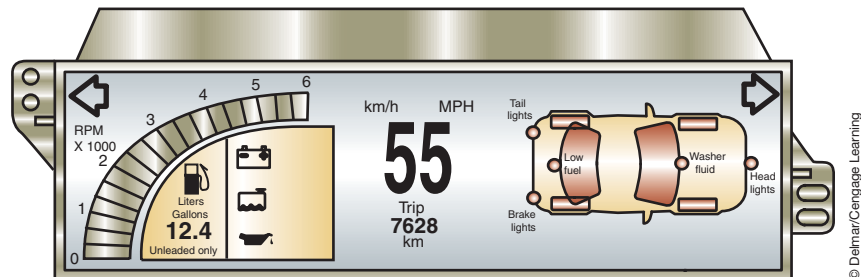


FIGURE 13-25 The digital fuel gauge displays remaining fuel in gallons or liters.

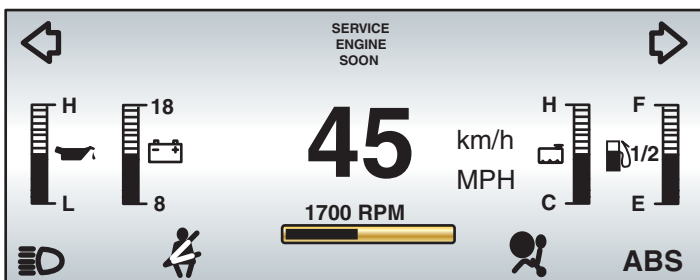


FIGURE 13-26 Bar graph style of electronic instrumentation. Each segment represents a different value.

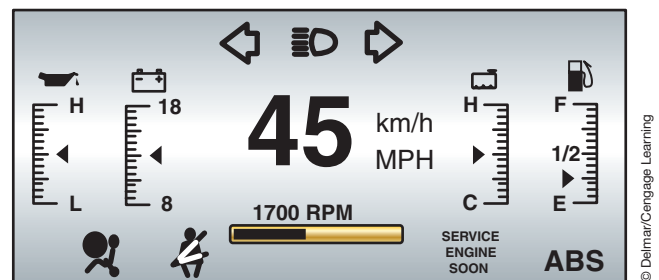


FIGURE 13-27 Floating pointer indicates the value received from the sensor.

to the microprocessor. This input signal is translated into a low-temperature reading on the gauge. As the engine coolant warms, the resistance value drops. At a predetermined resistance level, the microprocessor will activate an alert function to warn the driver of excessive engine temperature.

The voltmeter calculates charging voltage by comparing the voltage supplied to the instrument panel module to a reference voltage signal. The oil pressure gauge uses a piezoresistive sensor that operates like those used for conventional analog gauges.

Digital gauges perform self-tests. If a fault is found, a warning signal will be displayed to the driver. A “CO” indicates the circuit is open, a “CS” indicates the circuit is shorted. The gauge will continue to display these messages until the problem is corrected.

## HEAD-UP DISPLAY

Some manufacturers have equipped selected models with a **head-up display (HUD)** feature. This system displays visual images onto the inside of the windshield in the driver’s field of vision (Figure 13-28). With the display located in this area, drivers do not need to remove their eyes from the road to check the instrument panel. The images are projected onto the windshield from a vacuum fluorescent light source, much like a movie projector.

The head-up control module is mounted in the top of the instrument panel. This module contains a computer and an optical system that projects images to a holographic combiner integrated into the windshield above the module. The holographic combiner projects the images in the driver’s view just above the front end of the hood. The HUD contains the following displays and warnings:

1. Speedometer reading with USC/metric indicator.
2. Turn signal indicators.
3. High-beam indicator.
4. Low-fuel indicator.
5. Check gauges indicator.

The head-up control switch contains a head-up display on/off switch, USC/metric switch, and a head-up dimming switch. The head-up dimming switch is a rheostat that sends an input signal to the head-up module. The vertical position of the head-up display may be



© Delmar/Cengage Learning

**FIGURE 13-28** The HUD displays various information inside the windshield.

moved with one of the switches in the control switch assembly that is connected through a mechanical cable-drive system to the head-up module. Moving the vertical position switch moves the position of the head-up module.

The vehicle speed sensor signal information is sent from the PCM to the head-up module for the speedometer display. The check gauges and low-fuel signals are sent from the instrument cluster to the head-up module. A high-beam indicator input signal is sent from the dimmer switch to the head-up module. This module also receives inputs from the signal light switch to operate the signal light indicators.

## TRAVEL INFORMATION SYSTEMS

The travel information system can be a simple calculator that computes fuel economy, distance to empty, and remaining fuel (Figure 13-29). Other systems provide a much larger range of functions.

Fuel data centers display the amount of fuel remaining in the tank and provide additional information for the driver (Figure 13-30). By depressing the RANGE button, the BCM calculates the distance until the tank is empty by using the amount of fuel remaining and the average fuel economy. When the INST button is depressed, the fuel data center displays instantaneous fuel economy. The display is updated every 1/2 second and is computed by the BCM.

Depressing the AVG button displays average fuel economy for the total distance traveled since the reset button was last pushed. FUEL USED displays the amount of fuel that has been used since the last time this function was reset. The RESET button resets the average fuel

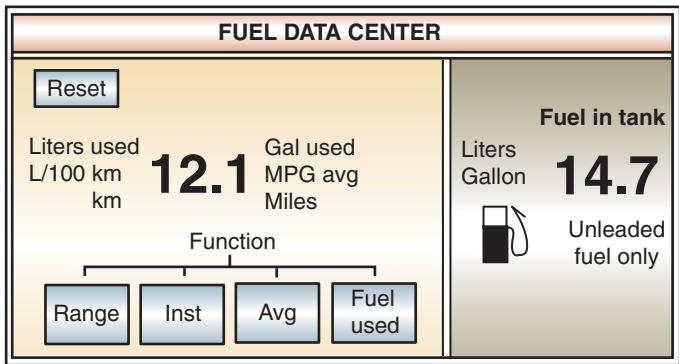
**Shop Manual**

Chapter 13, page 547



© Delmar/Cengage Learning

FIGURE 13-29 Fuel data display panel.



© Delmar/Cengage Learning

FIGURE 13-30 Fuel data center.

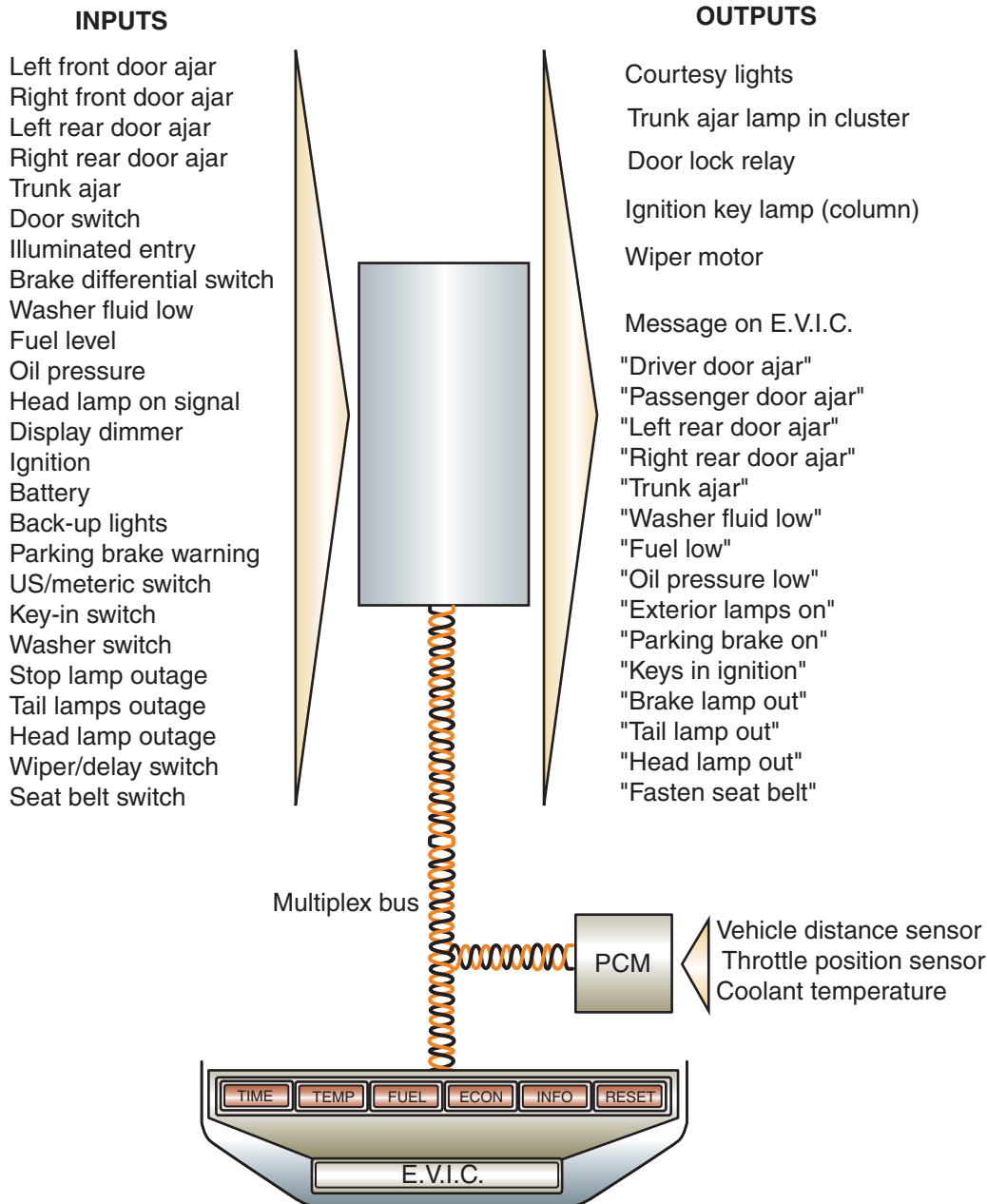
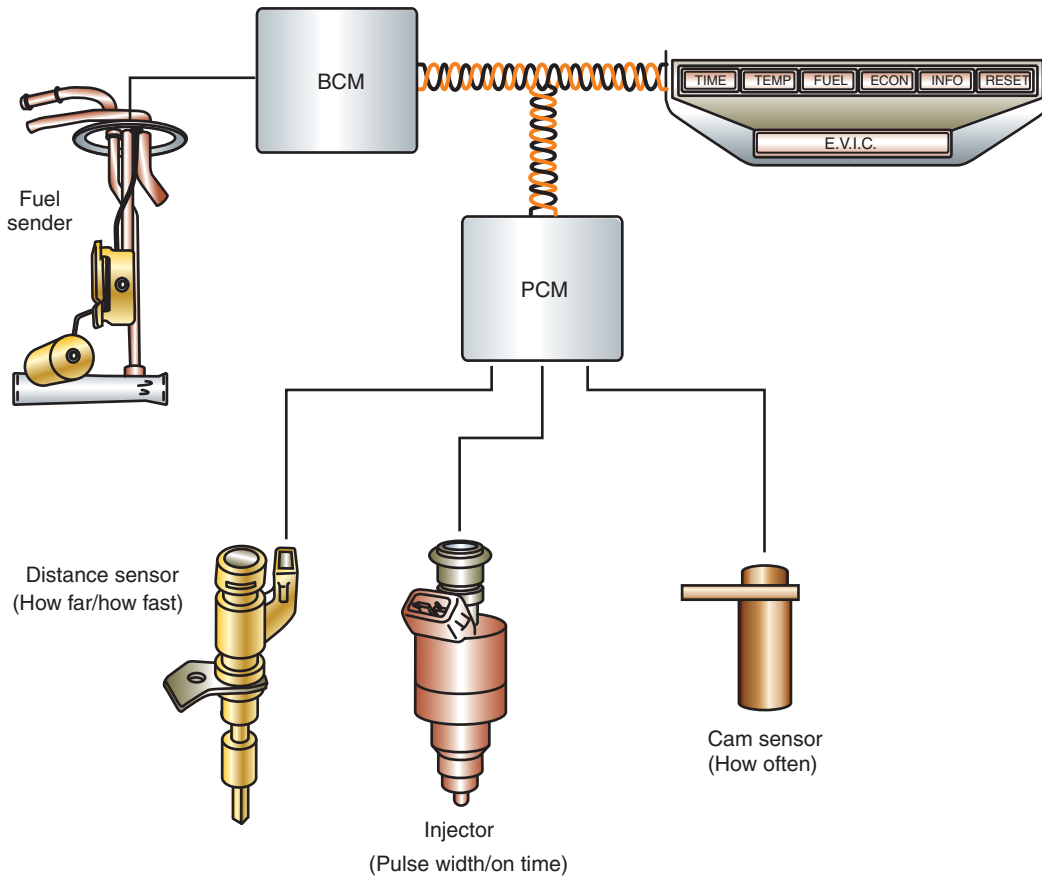


FIGURE 13-31 Inputs used for the electronic vehicle information center.

© Delmar/Cengage Learning

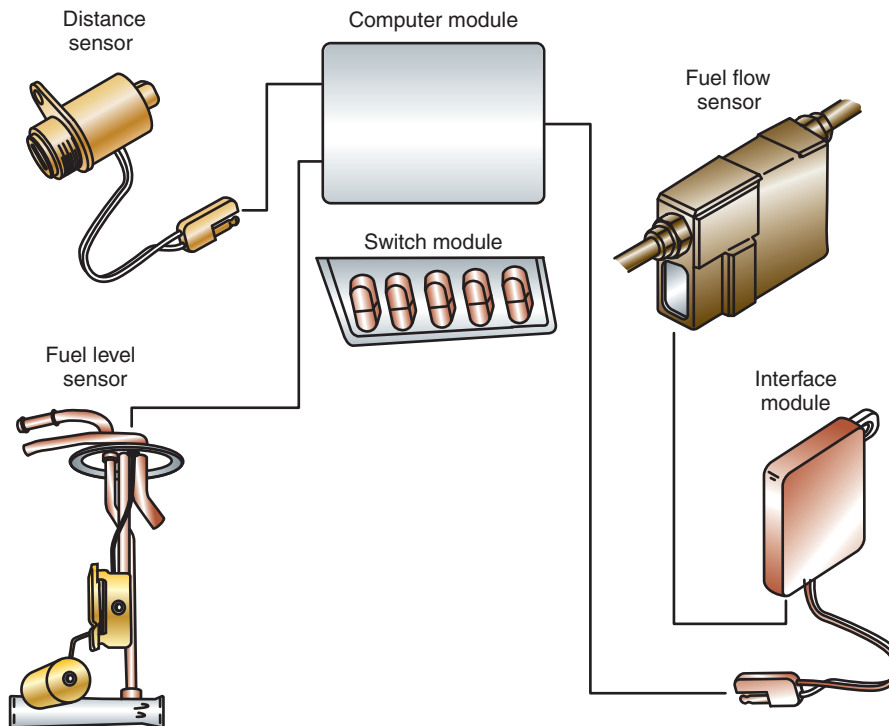
economy and fuel-used calculations. The function to be reset must be displayed on the fuel data center.

Deluxe systems may incorporate additional features such as outside temperature, compass, elapsed time, estimated time of arrival, distance to destination, day of the week, time, and average speed. The illustration (Figure 13-31) shows the inputs that are used to determine many of these functions. The sensors shown in Figure 13-32 determine fuel system calculations. Injector on time and vehicle speed pulses determine the amount of fuel flow. Some manufacturers use a fuel flow sensor that provides pulse information to the microprocessor concerning fuel consumption (Figure 13-33).



© Delmar/Cengage Learning

**FIGURE 13-32** Fuel data system inputs. The injector on time is used to calculate the rate of fuel flow.



© Delmar/Cengage Learning

**FIGURE 13-33** Some information centers use a fuel flow sensor.

## WARNING LAMPS

A **warning lamp** is a lamp that is illuminated to warn the driver of a possible problem or hazardous condition. A warning lamp may be used to warn of low oil pressure, high coolant temperature, defective charging system, or a brake failure. A warning lamp can be operated by two methods: a sending unit circuit hardwired to the instrument cluster, or computer-controlled lamp drivers.

### Sending Unit-Controlled Lamps

Unlike gauge sending units, the sending unit for a warning lamp is nothing more than a simple switch. The style of switch can be either normally open or normally closed, depending on the monitored system.

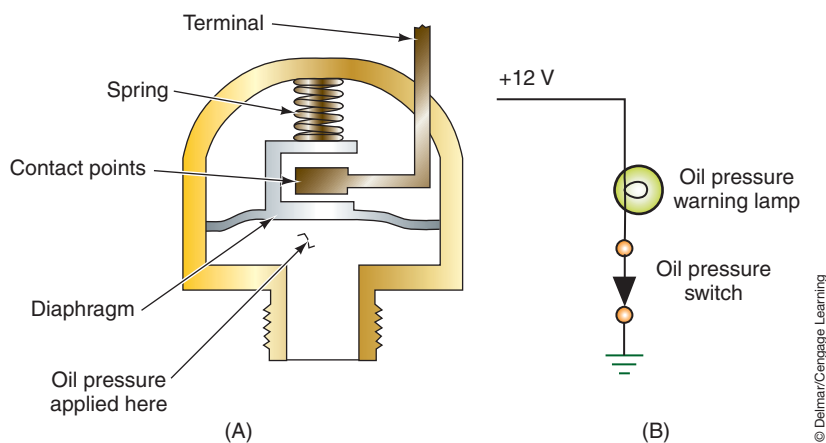
Most oil pressure warning circuits use a normally closed switch (Figure 13-34). A diaphragm in the sending unit is exposed to the oil pressure. The switch contacts are controlled by the movement of the diaphragm. When the ignition switch is turned to the RUN position with the engine not running, the oil warning lamp turns on. Because there is no pressure to the diaphragm, the contacts remain closed and the circuit is complete to ground. When the engine is started, oil pressure builds and the diaphragm moves the contacts apart. This opens the circuit and the warning lamp goes off. The amount of oil pressure required to move the diaphragm is about 3 psi. If the oil warning lamp comes on while the engine is running, it indicates that the oil pressure has dropped below the 3 psi limit.

Most coolant temperature warning lamp circuits use a normally open switch (Figure 13-35). The temperature sending unit consists of a fixed contact and a contact on a bimetallic strip. As the coolant temperature increases, the bimetallic strip bends. As the strip bends, the contacts move closer to each other. Once a predetermined temperature level has been exceeded, the contacts are closed and the circuit to ground is closed. When this happens, the warning lamp is turned on.

With normally open-type switches, the contacts are not closed when the ignition switch is turned to ON. In order to perform a bulb check on normally open switches, a **prove-out circuit** is included (Figure 13-36). A prove-out circuit completes the warning light circuit to ground through the ignition switch when it is in the START position. The warning light will be on during engine cranking to indicate to the driver that the bulb is working properly.

It is possible to have more than one sending unit connected to a single bulb. The illustration (Figure 13-37) shows a wiring circuit of a dual-purpose warning lamp. The lamp will come on whenever oil pressure is low or coolant temperature is too high.

Another system that is monitored with a warning lamp is the braking system. The illustration (Figure 13-38) shows a brake system combination valve. The center portion of the valve senses differences in the hydraulic pressures on both sides of the valve. With the differential



**FIGURE 13-34** (A) Oil pressure light sending unit. (B) Oil pressure warning lamp circuit.

**Shop Manual**  
Chapter 13, page 544

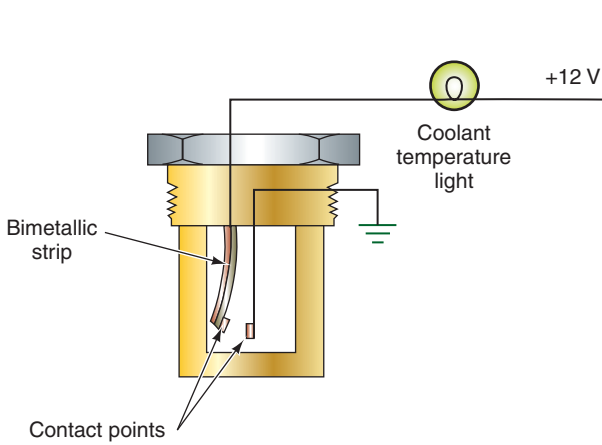
**Shop Manual**  
Chapter 13, page 547

The prove-out function is also known as “Bulb Test” or “Bulb Check” position.

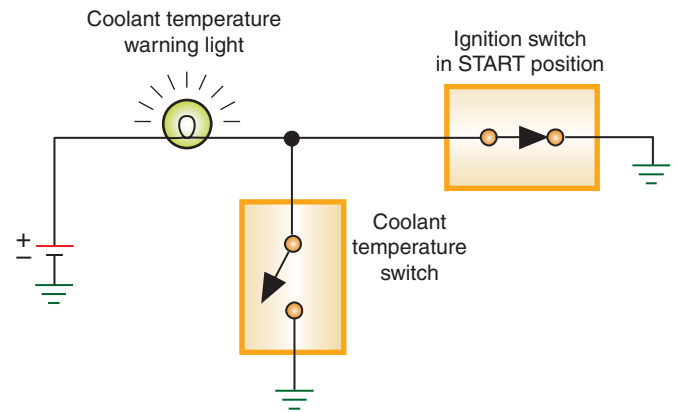
© Delmar/Cengage Learning



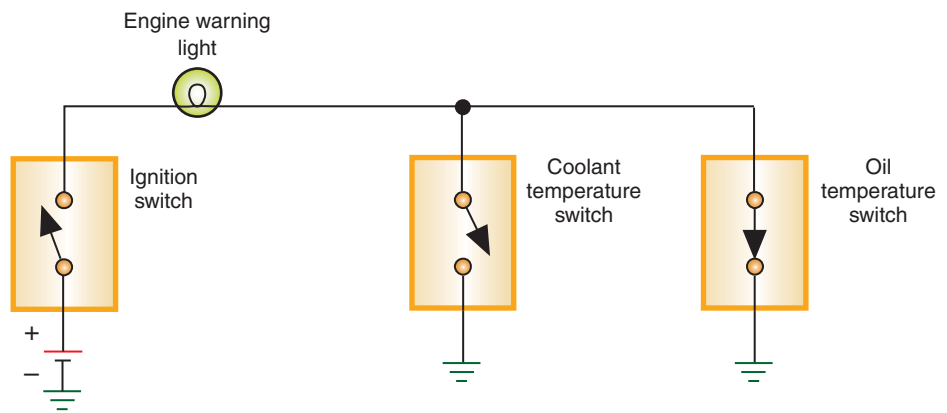
valve centered, the plunger on the warning lamp switch is in the recessed area of the valve. If the pressure drops in either side of the brake system, the differential valve will be forced to move by hydraulic pressure. When the differential valve moves, the switch plunger is pushed up and the switch contacts close.



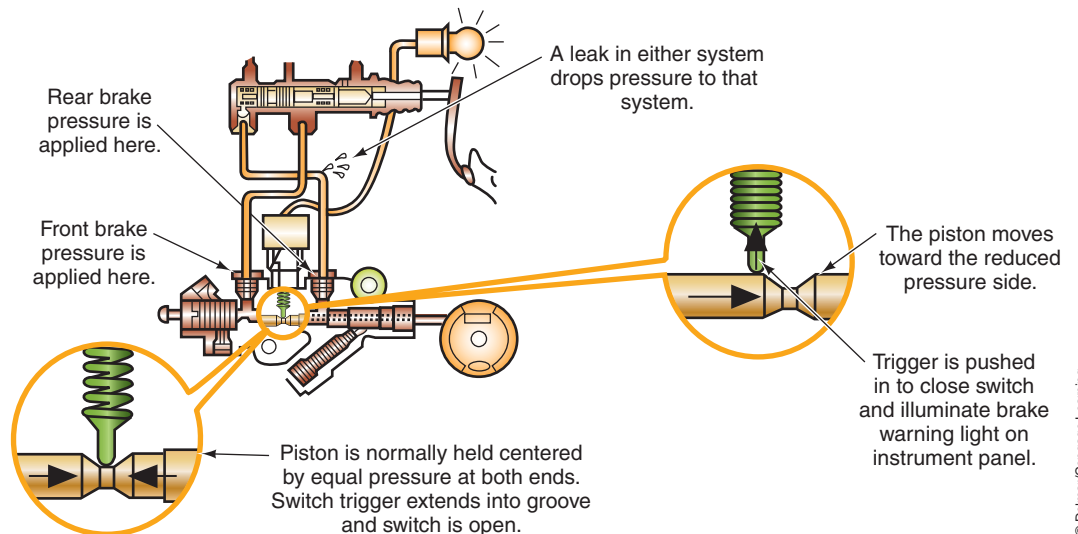
**FIGURE 13-35** Temperature indicator light circuit.



**FIGURE 13-36** A prove-out circuit included in a normally open (NO) coolant temperature light system.



**FIGURE 13-37** One warning lamp used with two sensors.



**FIGURE 13-38** Brake warning light switch as part of the combination valve.

## Computer-Driven Warning Lamp Systems

The computer-driven warning lamp system uses either high side or low side drivers to illuminate the warning lamp. Usually the driver module (instrument cluster or BCM) will receive a data bus message from the module that monitors the effected system that the warning lamp needs to be turned on. The driver module will then command the lamp on. For example, the PCM monitors the engine temperature. If the engine temperature reaches the upper threshold, the PCM will send a data bus message to the instrument cluster to turn on the warning lamp. The instrument cluster will activate its driver to illuminate the lamp. Usually the instrument cluster must receive a bus message from the monitoring module at a set time interval. If the message is not received, the warning lamp is illuminated. Some systems will illuminate a CHECK GAUGES lamp if the cluster uses a gauge and the gauge indicated a condition that the driver needs to be notified of.

### SUMMARY

---

- Through the use of gauges and indicator lights, the driver is capable of monitoring several engine and vehicle operating systems.
- The gauges include speedometer, odometer, tachometer, oil pressure, charging indicator, fuel level, and coolant temperature.
- The most common types of electromechanical gauges are the d'Arsonval, three-coil, two-coil, and air-core.
- Computer-driven quartz swing needle displays are similar in design to the air-core electromagnetic gauges used in conventional analog instrument panels.
- All gauges require the use of a variable resistance sending unit. Styles of sending units include thermistors, piezoresistive sensors, and mechanical variable resistors.
- Digital instrument clusters use digital and linear displays to notify the driver of monitored system conditions.
- The most common types of displays used on electronic instrument panels are: light-emitting diodes (LED), liquid crystal displays (LCDs), vacuum fluorescent displays (VFD), and a phosphorescent screen that is the anode.
- A head-up display system displays visual images onto the inside of the windshield in the driver's field of vision.
- In the absence of gauges, important engine and vehicle functions are monitored by warning lamps. These circuits generally use an on/off switch-type sensor. The exception would be the use of voltage-controlled warning lights that use the principle of voltage drop.

### REVIEW QUESTIONS

---

#### Short-Answer Essays

1. What are the most common types of electromagnetic gauges?
2. Describe the operation of the piezoresistive sensor.
3. What is a thermistor used for?
4. What is meant by *electromechanical*?
5. Describe the operation of the air-core gauge.
6. What is the basic difference between conventional analog and computer-driven analog instrument clusters?
7. Describe the operating principles of the digital speedometer.
8. Explain the operation of IC chip-type odometers.

**Shop Manual**  
Chapter 12, page 547

### TERMS TO KNOW

Air-core gauge  
Bucking coil  
Buffer circuit  
d'Arsonval gauge  
Digital instrument clusters  
Electromagnetic gauges  
Electromechanical  
Head-up display (HUD)  
H-gate  
High-reading coil  
International Standards Organization (ISO)  
Low-reading coil  
Odometer  
Oscillator  
Piezoresistive sensor  
Pinion factor  
Prove-out circuit  
Sending unit  
Speedometer  
Tachometer  
Thermistor  
Three-coil gauge  
Two-coil gauge  
Warning lamp  
Watchdog circuit

- Describe the operation of the electronic fuel gauge.
- Describe the operation of quartz analog speedometers.

### Fill in the Blanks

- The purpose of the tachometer is to indicate \_\_\_\_\_.
- A piezoresistive sensor is used to monitor \_\_\_\_\_ changes.
- The most common style of fuel level sending unit is \_\_\_\_\_ variable resistor.
- The brake warning light is activated by \_\_\_\_\_ pressure in the brake hydraulic system.
- In a three-coil gauge, the \_\_\_\_\_ produces a magnetic field that bucks or opposes the low-reading coil. The \_\_\_\_\_ coil and the bucking coil are wound together, but in opposite directions. The \_\_\_\_\_ coil is positioned at a 90° angle to the low-reading and bucking coils.
- A \_\_\_\_\_ circuit completes the warning light circuit to ground through the ignition switch when it is in the START position.
- Digital instrument clusters use \_\_\_\_\_ and \_\_\_\_\_ displays to notify the driver of monitored system conditions.
- \_\_\_\_\_ is a calculation using the final drive ratio and the tire circumference to obtain accurate vehicle speed signals.
- Most digital fuel gauges use a fuel level sender that \_\_\_\_\_ resistance value as the fuel level decreases.
- Computer-driven quartz swing needle displays are similar in design to the \_\_\_\_\_ electromagnetic gauges used in conventional analog instrument panels.

## MULTIPLE CHOICE

- Odometer replacement is being discussed.  
*Technician A* says that it is permissible to turn back the reading on a odometer as long as the customer is notified.  
*Technician B* says that if an odometer is replaced, it must be set to the same reading as the original odometer.  
Who is correct?  
A. A only            C. Both A and B  
B. B only            D. Neither A nor B
- Electromagnetic gauges are being discussed.  
*Technician A* says that the d'Arsonval gauge uses the interaction of a permanent magnet and an electromagnet, and the total field effect to cause needle movement.  
*Technician B* says that the three-coil gauge uses the interaction of three electromagnets and the total field effect upon a permanent magnet to cause needle movement.  
Who is correct?  
A. A only            C. Both A and B  
B. B only            D. Neither A nor B
- Technician A* says that the three-coil gauge uses the principle that electricity seeks the path of least resistance.  
*Technician B* says that the three coils used are the low-reading coil, a bucking coil, and a high-reading coil.  
Who is correct?  
A. A only            C. Both A and B  
B. B only            D. Neither A nor B
- Warning light circuits are being discussed.  
*Technician A* says that most oil pressure warning circuits use a normally closed switch.  
*Technician B* says most conventional coolant temperature warning light circuits use a normally open switch.  
Who is correct?  
A. A only            C. Both A and B  
B. B only            D. Neither A nor B

5. The brake failure warning system is being discussed. *Technician A* says if the pressure drops in either side of the brake system, the switch plunger is pushed up and the switch contacts close. *Technician B* says if the pressure is equal on both sides of the brake system, the warning light comes on. Who is correct?
- A. A only                      C. Both A and B  
B. B only                      D. Neither A nor B
6. The IC chip odometer is being discussed. *Technician A* says if the chip fails, some manufacturers provide for replacement of the chip. *Technician B* says depending on the manufacturer, the new chip may be programmed to display the last odometer reading. Who is correct?
- A. A only                      C. Both A and B  
B. B only                      D. Neither A nor B
7. Computer-driven quartz swing needle displays are being discussed. *Technician A* says the A coil is connected to system voltage and the B coil receives a voltage that is proportional to input frequency. *Technician B* says the quartz swing needle display is similar to air-core electromagnetic gauges. Who is correct?
- A. A only                      C. Both A and B  
B. B only                      D. Neither A nor B
8. *Technician A* says digital instrumentation displays an average of the readings received from the sensor. *Technician B* says conventional analog instrumentation gives more accurate readings but is not as decorative. Who is correct?
- A. A only                      C. Both A and B  
B. B only                      D. Neither A nor B
9. The microprocessor-initiated self-check of the electrical instrument cluster is being discussed. *Technician A* says during the first portion of the self-test all segments of the speedometer display are lit. *Technician B* says the display should not go blank during any part of the self-test. Who is correct?
- A. A only                      C. Both A and B  
B. B only                      D. Neither A nor B
10. *Technician A* says bar graph-style gauges do not provide for self-tests. *Technician B* says the digital instrument panel will display CO to indicate the circuit is shorted. Who is correct?
- A. A only                      C. Both A and B  
B. B only                      D. Neither A nor B

# Chapter 14

## ACCESSORIES

### UPON COMPLETION AND REVIEW OF THIS CHAPTER, YOU SHOULD BE ABLE TO UNDERSTAND AND DESCRIBE:

- The operation and function of the horn circuit.
- The operation of standard two- and three-speed wiper motors, both permanent magnet and electromagnetic field designs.
- The operation of intermittent wipers.
- How depressed-park wipers operate.
- The function of intelligent windshield wiper systems.
- The operation of windshield washer pump systems.
- The operation and methods used to control blower fan motor speeds.
- The operation of electric defoggers.
- Operational principles of power mirrors.
- The principles of operation for power windows, power seats, and power locks.
- The operating principles of the memory seat feature
- The purpose and operation of automatic door lock systems.
- The operation of the keyless entry system.
- The operation of common antitheft systems.
- The function of immobilizer security systems.
- The purpose of the cruise control system.
- The operating principles of the electronic cruise control system.
- The concepts of electronically controlled sunroofs.
- The operating principles of Ford and GM's heated windshield systems.
- The purpose and configuration of vehicle audio and entertainment systems.

### INTRODUCTION

Electrical accessories provide additional safety and comfort. There are many electrical accessories that can be installed into today's vehicles. This chapter explains the principles of operation for some of the most common electrical accessories. Systems not discussed here are similar in concept.

This chapter explores the operation of safety accessories, such as the horn, windshield wipers, and windshield washers. Comfort accessories explored in this chapter include the blower motor, electric defoggers, power mirrors, power windows, power seats, and power door locks.

In today's automobile there is no system that computers cannot control. The vehicle may be equipped with computer-controlled wipers, transmissions, locking differentials, brakes, suspensions, all-wheel drive systems, and so on. It would be impossible to cover the various operations of all these systems. It is important for today's technician to have an understanding of how electronics work and a basic knowledge of the control system. Whether you are working on a domestic or foreign-built automobile, electricity and electronics work the same. Always refer to the proper service information to get an understanding of a system that may be new to you.

In addition to electrical accessories, this chapter discusses several of the electronic systems found in today's automobiles. Some of these systems are covered in greater detail in other *Today's Technician* series books. Refer to these textbooks for more information.

In this chapter, you will learn the operation of cruise control systems and the many electrical accessory systems that have electronic controls added to them for added features and enhancement. These accessories include memory seats, electronic sunroofs, antitheft systems, automatic door locks, keyless entry, and electronically heated windshields.

The comfort and safety of the driver and/or passengers depend on the technician properly diagnosing and repairing these systems. As with all electrical systems, the technician must have a basic understanding of the operation of these systems before attempting to perform any service.

## HORNS

The automotive electrical horn operates on an electromagnetic principle that vibrates a **diaphragm** to produce a warning signal. The diaphragm is a thin, flexible, circular plate that is held around its outer edge by the horn housing, allowing the middle to flex. Most electrical horns consist of an electromagnet, a moveable armature, a diaphragm, and a set of normally closed contact points (Figure 14-1). The contact points are wired in series with the field coil. One of the points is attached to the armature. When current flows through the field coil, a magnetic field is developed that attracts the moveable armature. The diaphragm is attached to and moves with the armature. Movement of the armature results in the contact points opening, which breaks the circuit. The diaphragm is released and returns to its normal position. The contact points close again and the cycle repeats. This vibration of the diaphragm is repeated several times per second.

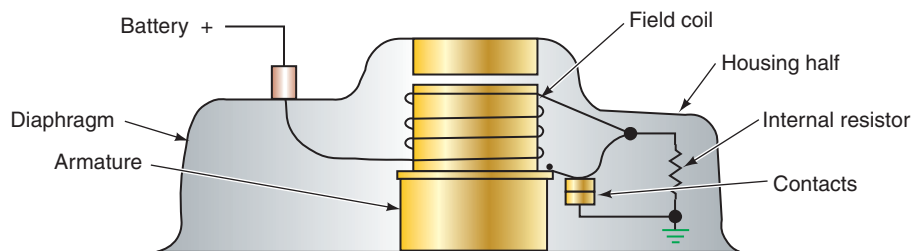
As the diaphragm vibrates, it causes a column of air in the horn to vibrate. The vibration of the column of air produces the sound.

Most vehicles are equipped with two horns that are wired in parallel with each other and in series with the switch. One of the horns will have a slightly lower pitch than the other. The design and shape of the horn determines the frequency and tone of the sound (Figure 14-2). Pitch is controlled by the number of times the diaphragm vibrates per second. The faster the vibration, the higher the pitch. The horn pitch can be adjusted by changing the spring tension of the armature. This alters the magnetic pull on the armature and changes the rate of vibrations. The adjustment is made on the outside of the horn (Figure 14-3).

## Horn Switches

Horn switches are installed either in the steering wheel or as a part of the multifunction switch. Most horn switches are normally open switches.

The steering wheel-mounted horn switch can be a single button in the middle of the steering wheel. Another design is to have multiple buttons in the horn pad. Switches mounted



**FIGURE 14-1** Horn construction. The internal resistor allows a weak magnetic field to remain after the contacts open, reducing the amount of time required to rebuild the field when the contacts close again.

### Shop Manual

Chapter 14, page 562

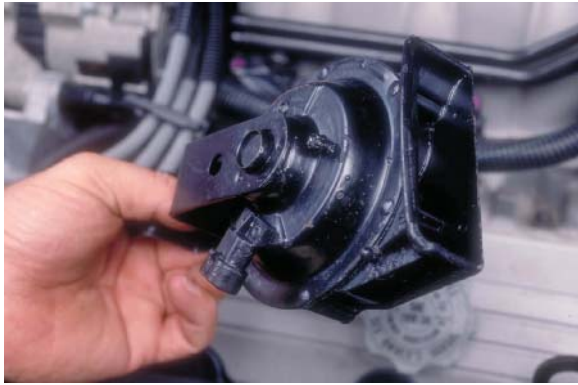
A horn is a device that produces an audible warning signal.

When two horns are used on a vehicle, one is called the low-note horn and the other is called the high-note horn.

### Shop Manual

Chapter 14, page 562





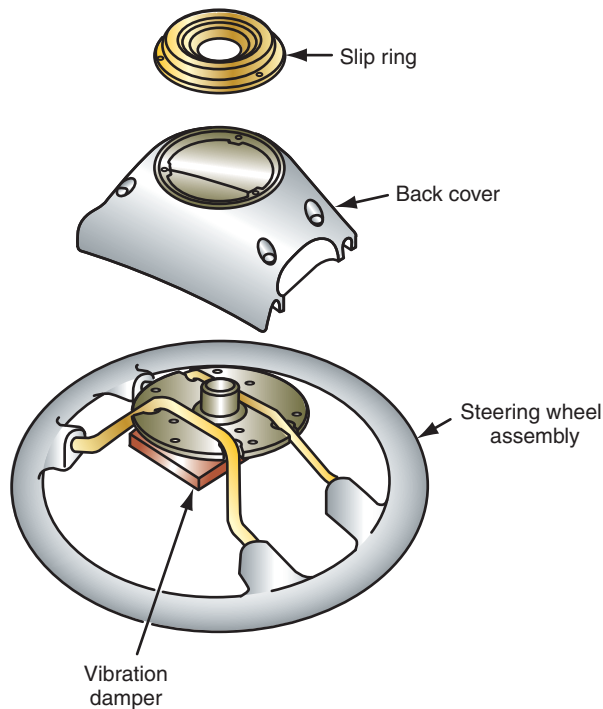
© Delmar/Cengage Learning

**FIGURE 14-2** Horn design affects sound quality.



© Delmar/Cengage Learning

**FIGURE 14-3** Horn pitch adjustment screw.

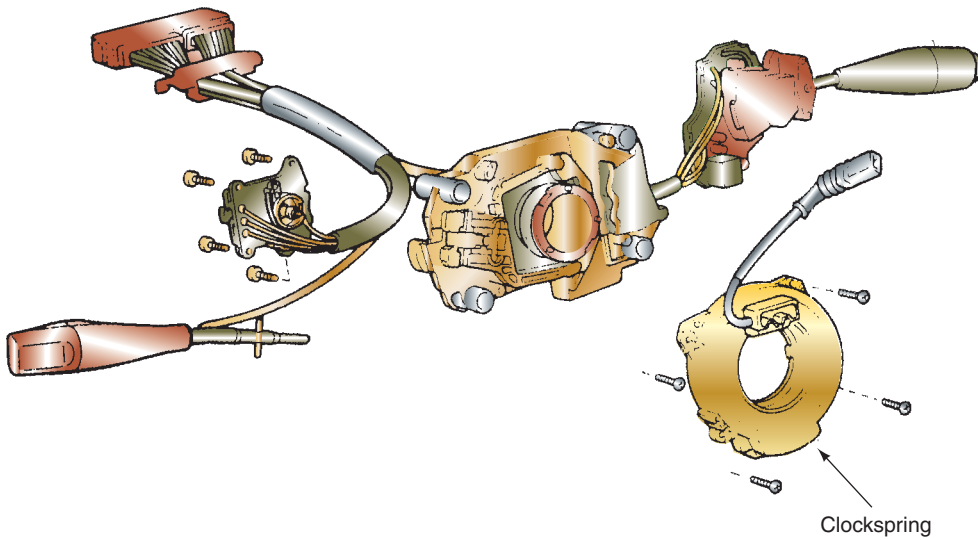


© Delmar/Cengage Learning

**FIGURE 14-4** Slip ring contact provides horn continuity in all steering wheel positions.

on the steering wheel require the use of a slip ring (Figure 14-4). The slip ring has contacts that provide continuity for the horn control in all steering wheel positions. The contacts consist of a circular contact in the steering wheel that slides against a spring-loaded contact in the steering column. Most vehicle manufacturers now use a **clockspring** (Figure 14-5) to provide continuity between the steering wheel components—horn switch, cruise control switches, air bag, and so on—and the steering column wiring harness. A clockspring is a winding of electrical conducting tape enclosed within a plastic housing. The clockspring maintains continuity between the steering wheel switches, the air bag, and the wiring harness in all steering wheel positions. The clockspring provides a more reliable connection than the sliding contacts.

Horn switches that are a part of the multifunction switch usually operate by a push button on the end of the lever.



© Delmar/Cengage Learning

**FIGURE 14-5** Most vehicle manufacturers now use a clockspring instead of sliding contacts.

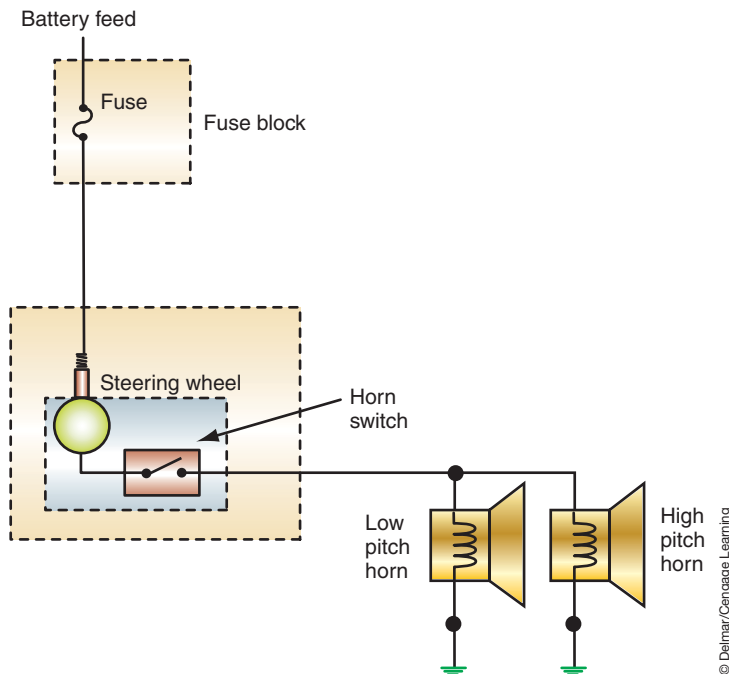
## Horn Circuits

There are two methods of circuit control: with or without a relay. If the horn circuit does not use a relay, the horns must be of low current design because the horn switch carries the total current. Depressing the horn switch completes the circuit from the battery to the horns (Figure 14-6).

The most common type of circuit control is to use a relay (Figure 14-7). Most circuits have battery voltage present to the lower contact plate of the horn switch. When the switch is depressed, the contacts close and complete the circuit to ground. Only low current is required to operate the relay coil, so the horn switch does not have to carry the heavy current requirements of the horns. When the horn switch is closed, it energizes the relay core. The core

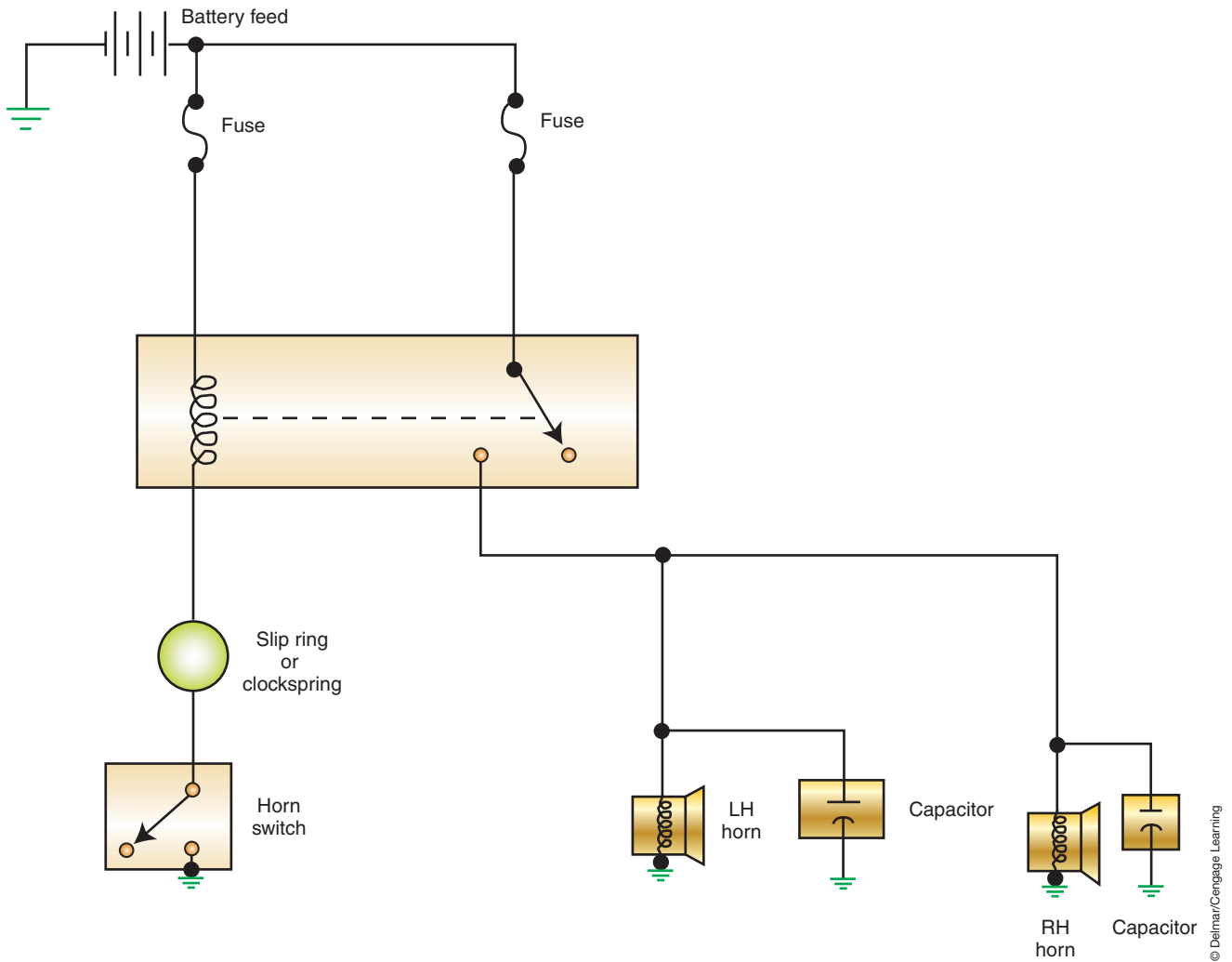
**Shop Manual**

Chapter 14, page 562



© Delmar/Cengage Learning

**FIGURE 14-6** Insulated side switch without relay.



**FIGURE 14-7** Relay-controlled horn circuit. The horn button completes the relay coil circuit.

attracts the relay armature, which closes the contacts and completes the horn circuit. Current flows from the battery to the grounded horns.

Many vehicle manufactures now use a module (or series of modules) to operate the horn. This reduces wiring and utilized modules that can perform multiple functions. As a side effect to the use of modules, many are capable of performing diagnostic routines and setting DTCs to assist the technician in diagnostics. Consider the system illustrated in Figure 14-11. In this system, the steering wheel switches are used for radio and navigational system controls. The left steering switch is hard wired to the right switch. However, the right switch is more than just a switch. It is a slave microprocessor that puts inputs it receives onto the LIN bus to the master LIN module (steering column module). The steering column module then puts the message onto the CAN B bus network so other modules receive the input request made by the operator using the steering wheel switches. In Figure 14-8, the right steering wheel switch (LIN slave module) monitors the horn switch input. If the vehicle operator presses the horn switch, the right steering wheel switch sees a change in voltage on the signal circuit. It then broadcasts the horn request signal to the steering column module. The steering column module in turn broadcasts the request on the CAN B bus network to the front control module. The front control module then activates a high-side driver to supply current to the horns. As you can see from this example, this system uses three microprocessors and two bus networks to operate the horns.

**Shop Manual**

Chapter 14, page 565

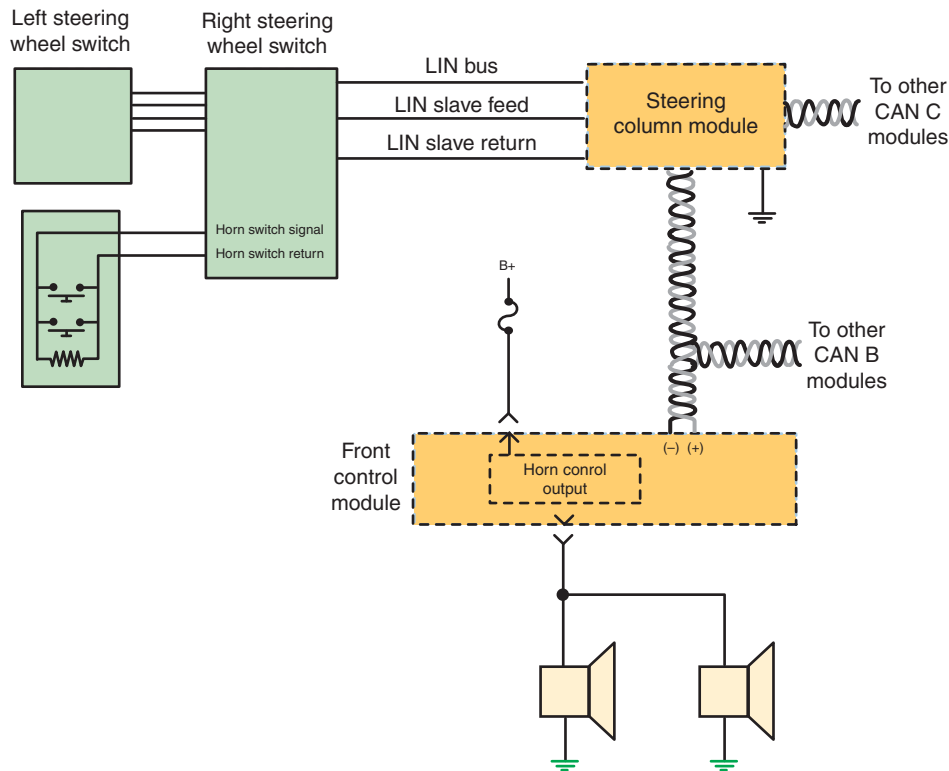


FIGURE 14-8 Horn circuit utilizing computers and bus networks.

© Delmar/Cengage Learning

## WINDSHIELD WIPERS

There are two types of windshield wiper systems being used today:

1. A standard two- or three-speed system.
2. A two- or three-speed system with an intermittent feature.

On most models, the same motor is used for either the standard or intermittent system. Both can have a **depressed-park** feature. In systems equipped with depressed park, the blades drop down below the lower windshield molding to hide them.

A single-speed rear window wiper and washer is used on many vehicles. In addition, headlight wipers are installed on many luxury vehicles that operate in union with the windshield wipers (Figure 14-9). The operation of these accessories is the same as the windshield wipers.



FIGURE 14-9 Headlight wipers.

© Delmar/Cengage Learning

### Shop Manual

Chapter 14, page 566



### A BIT OF HISTORY

Windshield wipers were introduced at the 1916 National Auto Show by several manufacturers. These were hand operated. Vacuum-operated wipers were standard equipment by 1923. Electric wipers became common in the 1950s.

Most wiper circuits use a circuit breaker to prevent temporary overloads from totally disabling the windshield wipers due to a blown fuse.

## Wiper Motors

Windshield wipers are mechanical arms that sweep back and forth across the windshield to remove water, snow, or dirt. Most windshield wiper motors use permanent magnet fields. Motor speed is controlled by the placement of the brushes on the commutator. Three brushes are used: common, high speed, and low speed. The common brush carries current whenever the motor is operating. The low-speed and high-speed brushes are placed in different locations, based on motor design:

1. The high-speed and common brushes oppose each other, with the low-speed brush offset (Figure 14-10).
2. The low-speed and common brushes oppose each other with the high-speed brush offset or centered between them (Figure 14-11). This is the most common brush arrangement.

The placement of the brushes determines how many armature windings are connected in the circuit. There are fewer armature windings connected between the common and high-speed brushes. When battery voltage is applied to fewer windings, there is less magnetism in the armature and a lower counterelectromotive force (CEMF). With less CEMF in the armature, there is greater armature current. The greater armature current results in higher speeds.

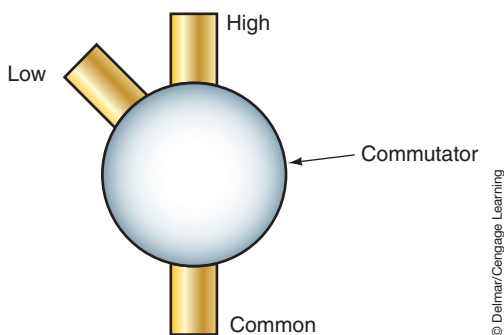
There are more armature windings connected in the circuit between the common and low-speed brushes. With more windings, the magnetic field in the armature is increased. This results in greater CEMF. The increased CEMF reduces the amount of current in the armature and slows the speed of the motor.

Some two-speed, and all three-speed wiper motors use two electromagnetic field windings instead of permanent magnets (Figure 14-12). The two field coils are wound in opposite directions so that their magnetic fields will oppose each other. The series field is wired in series with the motor brushes and commutator. The shunt field forms a separate circuit branch off the series field to ground. The strength of the total magnetic field will determine the speed of the motor.

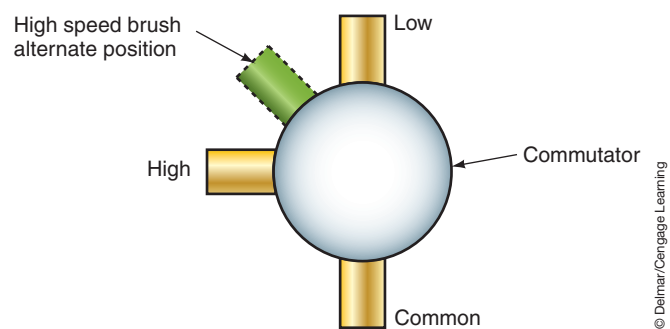
**Shop Manual**  
Chapter 14, pages  
566, 569

## Permanent Magnet Wiper Circuits

A set of **park contacts** are incorporated into the motor assembly and operate off a cam or latch arm on the motor gear (Figure 14-13). Park contacts are located inside the motor assembly, and supply current to the motor after the wiper control switch has been turned to the PARK position. This allows the motor to continue operating until the wipers have reached their park position. The park switch changes position with each revolution of the motor. The switch remains in the RUN position for approximately 90% of the revolution. It is in the PARK position for the remaining 10% of the revolution. This does not affect the operation of the motor until the wiper control switch is placed in the PARK position.



**FIGURE 14-10** One style of brush arrangement has the high-speed brush opposite of the common brush.

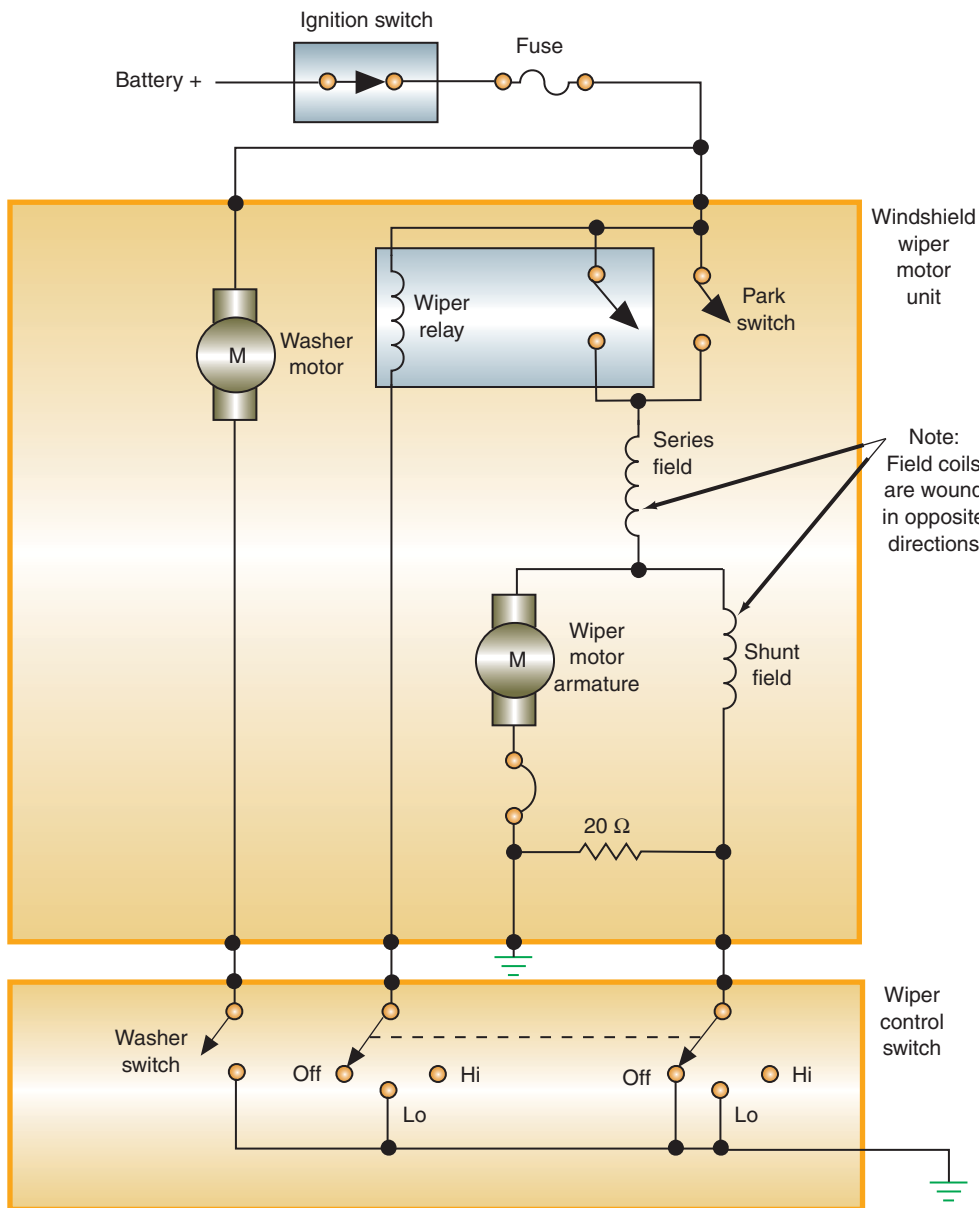


**FIGURE 14-11** The most common brush arrangement is to place the low-speed brush opposite of the common brush.



## A BIT OF HISTORY

The first windshield wipers were hand operated. Most of the early powered wiper systems were operated by engine vacuum. Many times the wipers would not operate when the vehicle was driven up a hill because of the loss of engine vacuum under those conditions. In 1968, federal law mandated that all vehicles must be equipped with a two-speed wiper and washer system. American Motors Corporation continued to use a two-speed vacuum motor until the 1970s; all other manufacturers converted to electric motors.



Windshield wiper motor unit

Note: Field coils are wound in opposite directions

Wiper control switch

© Delmar/Cengage Learning

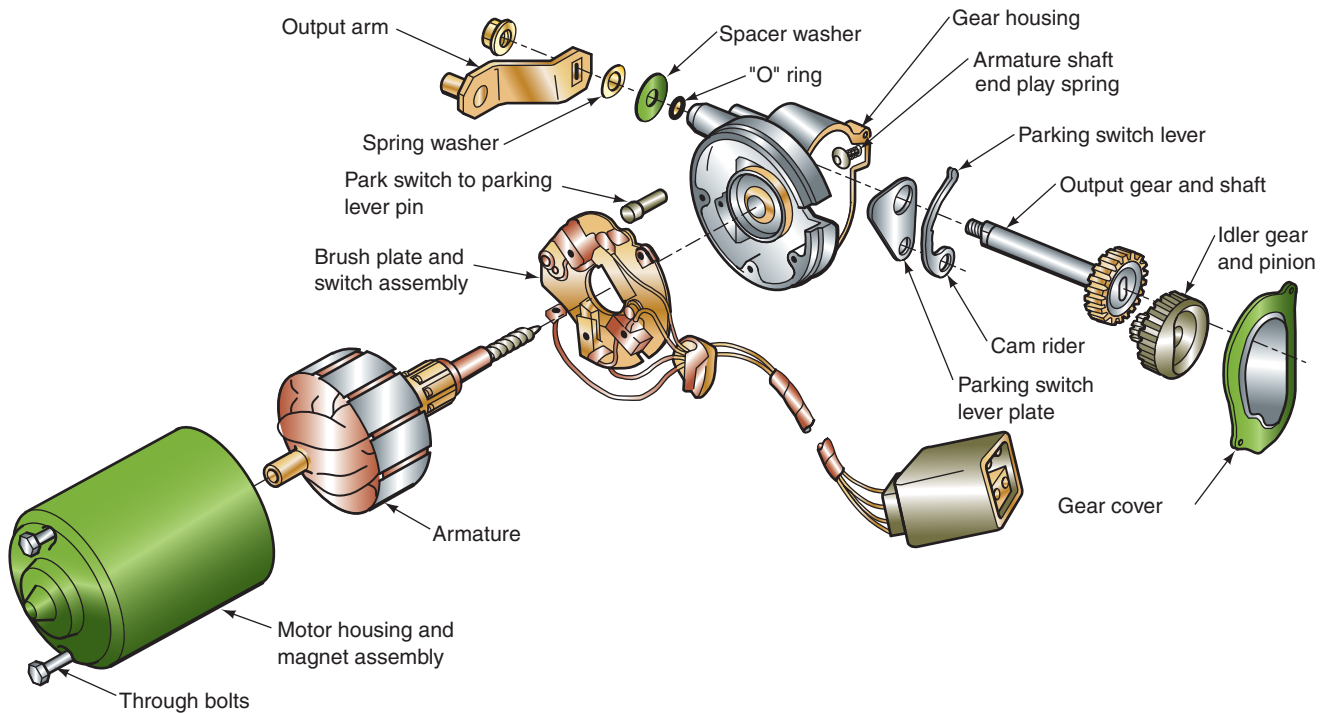
**FIGURE 14-12** Schematic of wiper system that uses an electromagnetic field motor.

When the wiper control switch is in the HIGH-SPEED position, battery voltage is supplied through wiper 1 to the high-speed brush (Figure 14-14). Wiper 2 moves with wiper 1 but does not complete any circuits. Current flows through the low-speed brush, the armature, and the common brush to ground. Because the ground connection is before the park switch, the park switch position has no effect on motor operation.

When the switch is placed in the LOW-SPEED position, battery voltage is supplied through wiper 1 to the low-speed brush (Figure 14-15). Wiper 2 also moves to the LOW position, but does not complete any circuits. Current flows through the armature, the low-speed brush, and the common brush to ground. Park switch position has no effect on motor operation.

When the switch is returned to the OFF position, wiper 1 opens (Figure 14-16). Battery voltage is applied to the park switch. Wiper 2 is closed to allow current to flow to the low-speed brush, through the armature, and to ground. When the wiper blades are in their lowest position, the park switch is moved to the PARK position. This opens the circuit to the low-speed brush and the motor shuts off.





**FIGURE 14-13** Park switch components.

© Delmar/Cengage Learning

**Shop Manual**

Chapter 14, page 566

## Electromagnetic Field Wiper Circuits

Electromagnetic field motors use two fields that are wired in opposite directions: the series field and the shunt field. Resistors are used in series with one of the fields to control the strength of the total magnetic field. The wiper control switch directs the current flow through the resistors to obtain the desired motor speed. Circuit operation varies between two- and three-speed systems.

**Two-Speed Motors.** The ground side switch will determine the current path. One path is directly to ground after the field coil, the other is through a 20-ohm resistor (Figure 14-17).

With the switch in the OFF position, switch wiper 1 breaks the circuit through the relay to ground. Because the relay is not energized, current is not supplied to the motor.

When the switch is placed in the LOW-SPEED position, wiper 1 completes the relay coil circuit to ground. The energized relay closes the contacts and applies current to the motor, through the series field and shunt field coils. Wiper 2 provides the ground path for the shunt field coil. Because there is less resistance to ground through wiper 2, the 20-ohm resistor is bypassed. With no resistance in the shunt field coil, the shunt field is very strong and bucks the magnetic field of the series field. The result is slow motor operation.

When the switch is located in the HIGH-SPEED position, wiper 1 completes the relay coil circuit to ground. This closes the relay contacts to the series field and shunt field coils. Wiper 2 opens the circuit to ground and current must now pass through the 20-ohm resistor to ground. The resistor reduces the current flow and strength of the shunt field. With less resistance from the shunt field, the series field is able to turn the motor at an increased speed.

When the switch is returned to the OFF position, wiper 1 opens the relay coil circuit. The relay is de-energized, but the contact points to the series and shunt field coils are manually held closed by the park switch. The park switch is closed until the wipers are in their lowest position. Wiper 2 closes the circuit path to ground. As long as the park switch is closed, current flows through the series field, shunt field, and wiper 2 to ground.



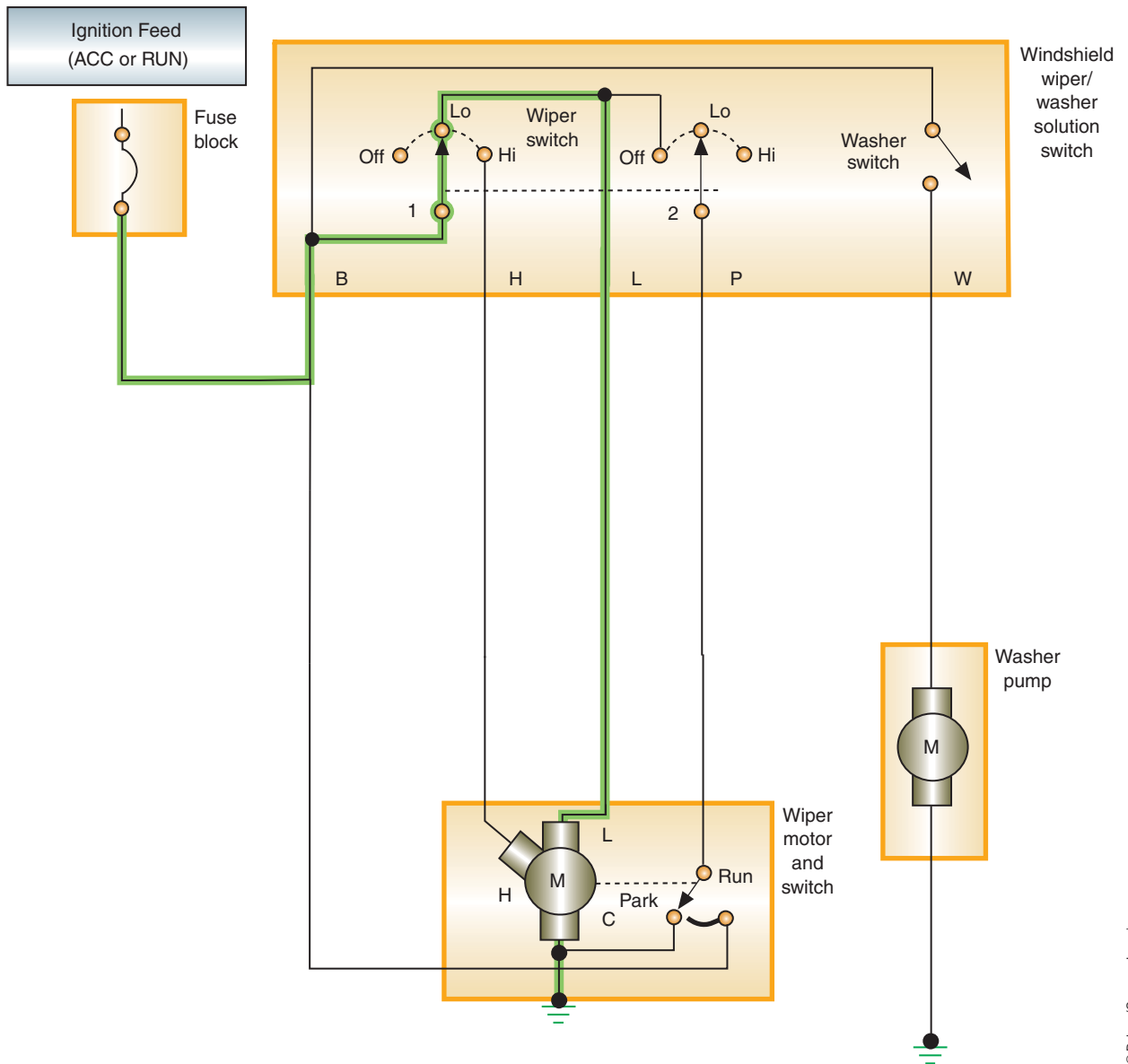


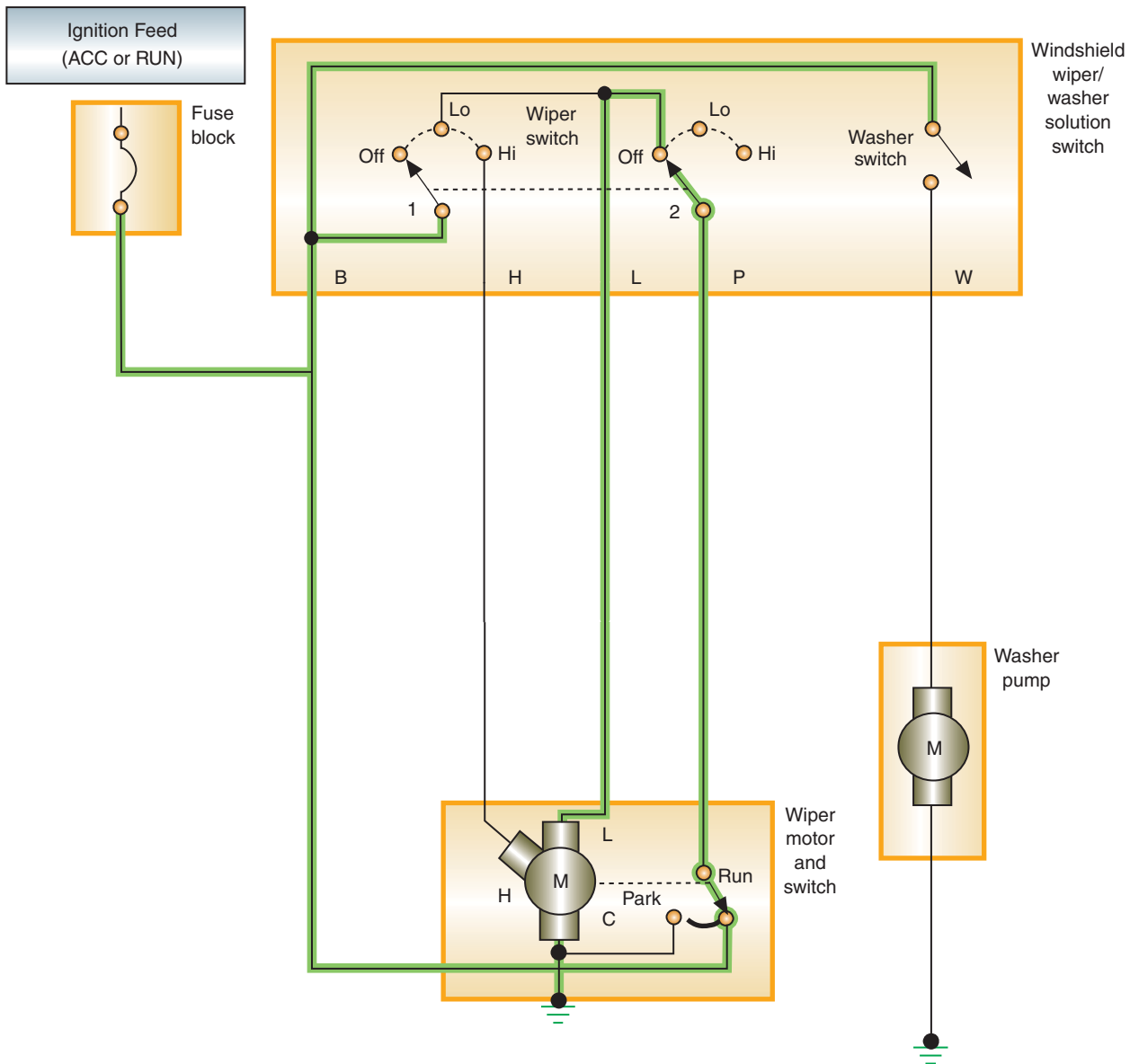
FIGURE 14-15 Current flow in LOW position.

## Relay-Controlled, Two-Speed Wiper Systems

To reduce the size of the wires through the steering column harness, a wiper system may use relays to supply current to the wiper motor (Figure 14-20). With the ignition switch in the RUN or ACC position, battery voltage is supplied to the wiper motor and to the coils of the ON/OFF and HI/LO relays. If the wiper switch is placed in the LOW speed position, the coil of the ON/OFF relay is energized. The contacts of the ON/OFF relay now provide ground for the wiper motor. Since the Hi/Lo relay coil is not energized, current flows through the motor's low-speed brush to ground.

When the wiper switch is placed in the HIGH-SPEED position, the switch provides ground for both the wiper ON/OFF and the wiper Hi/Lo relay coils. The wiper Hi/Lo relay is a circuit diverter and now provides ground for the wiper motor's high-speed brush through the contacts of the wiper ON/OFF relay (which remains energized).

This system may also incorporate an intermittent wipe module that provides a parallel path to ground for the ON/OFF relay coil. The relay is energized long enough to activate the



**FIGURE 14-16** Current flow when the wipers are parking.

© Delmar/Cengage Learning

wiper motor. Once the wipers move, the park switch closes and the motor continues to run until the wipers are in the park location. At this time, the park switch opens and the motor stops. After the delay period has expired, the process is repeated.

## Intermittent Wipers

Many wiper systems offer an intermittent mode that provides a variable interval between wiper sweeps. Many of these systems use a module located in the steering column. If the intermittent wiper mode is initiated when the wipers are in their parked position, the park switch is in the ground position. Current is sent to the solid-state module to the “timer activate” terminal. The internal timer unit “triggers” the electronic switch to close the circuit for the governor relay, which then closes the circuit to the low-speed brush (Figure 14-21). The wiper will operate until the park switch swings back to the PARK position.

The delay between wiper sweeps is determined by the amount of resistance the driver puts into the potentiometer control. By rotating the intermittent control knob, the resistance

**Shop Manual**  
Chapter 14, page 571

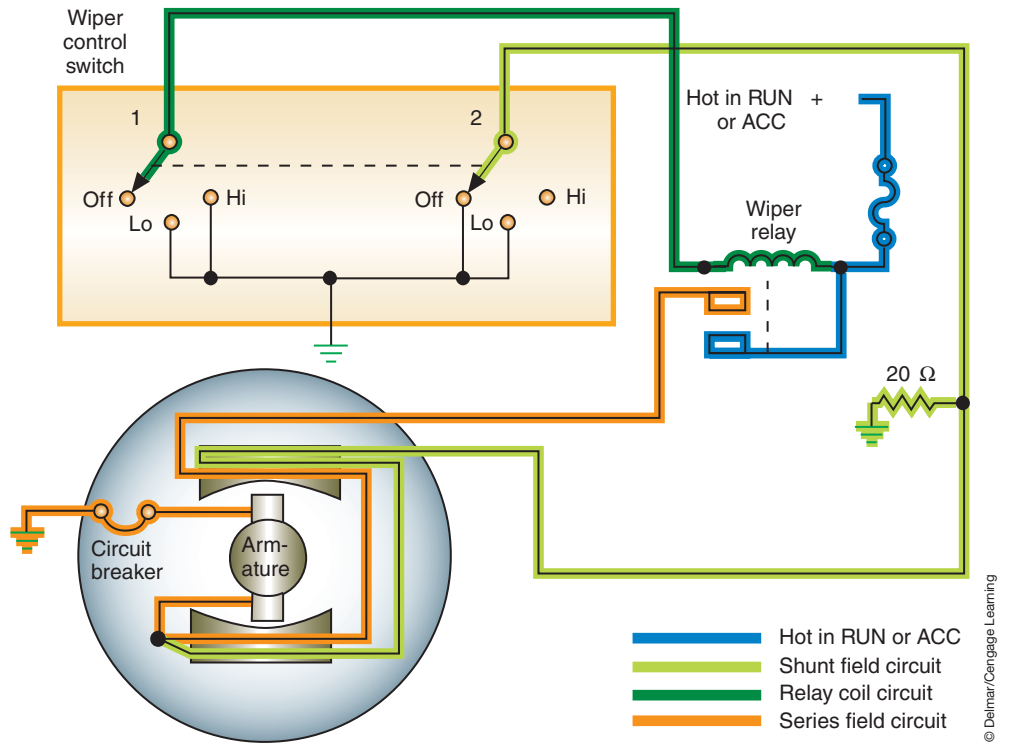


FIGURE 14-17 Simplified diagram of an electromagnetic field, two-speed wiper system.

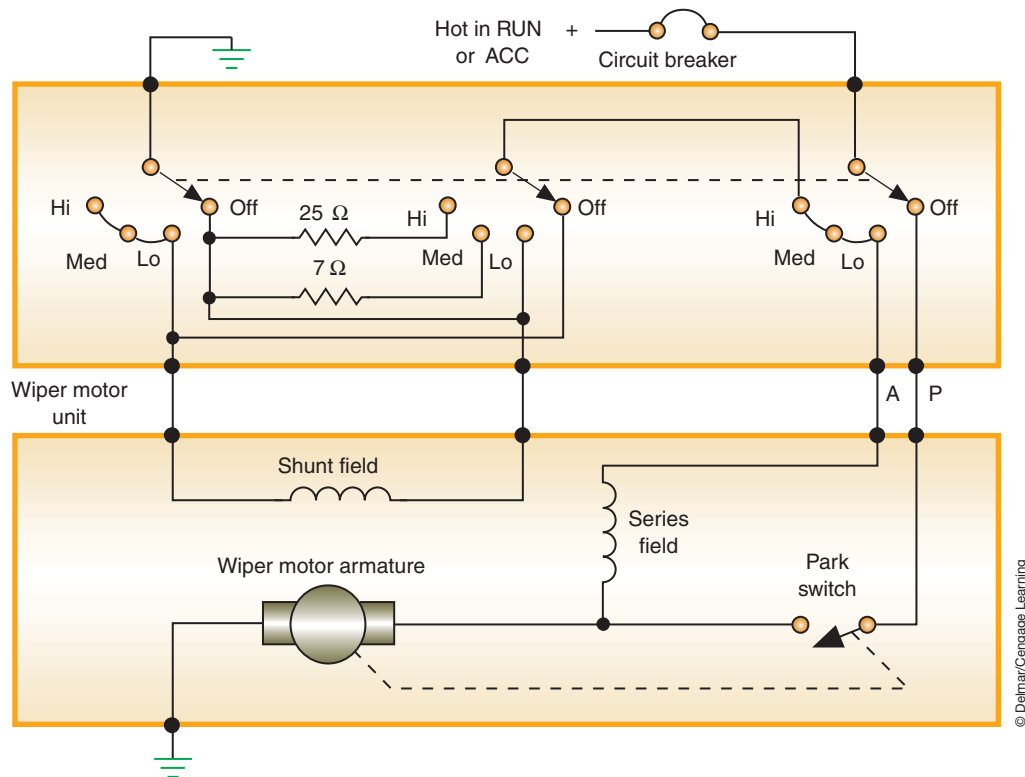
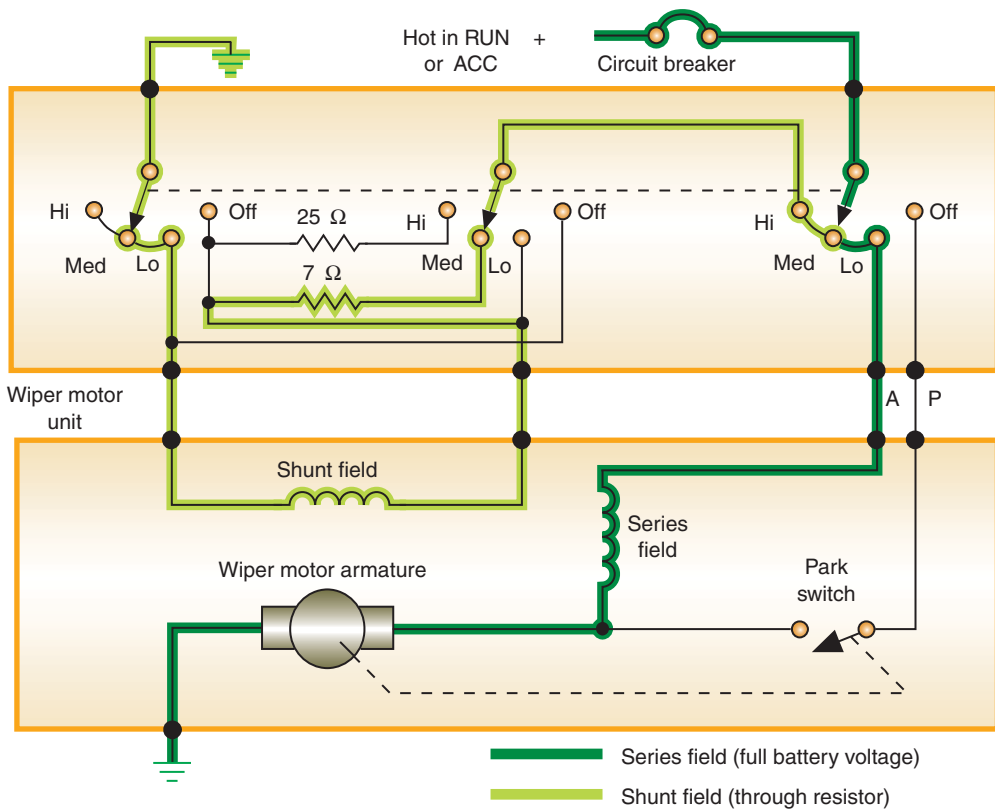
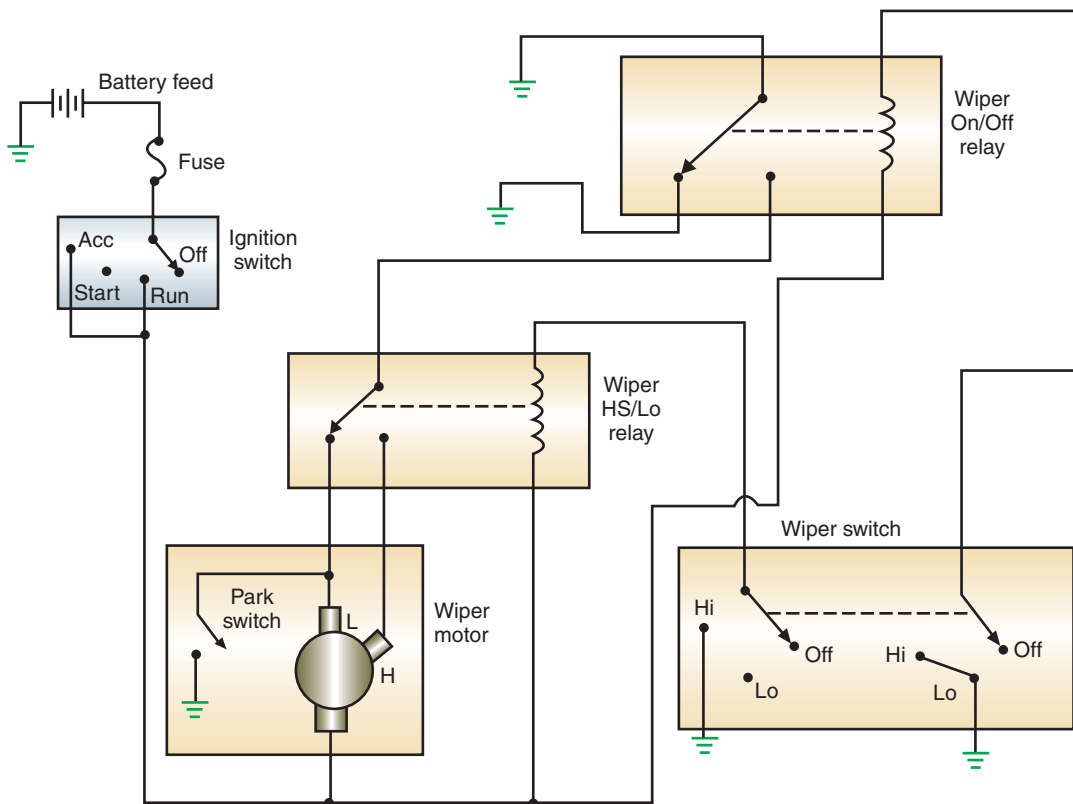


FIGURE 14-18 Three-speed wiper motor schematic.

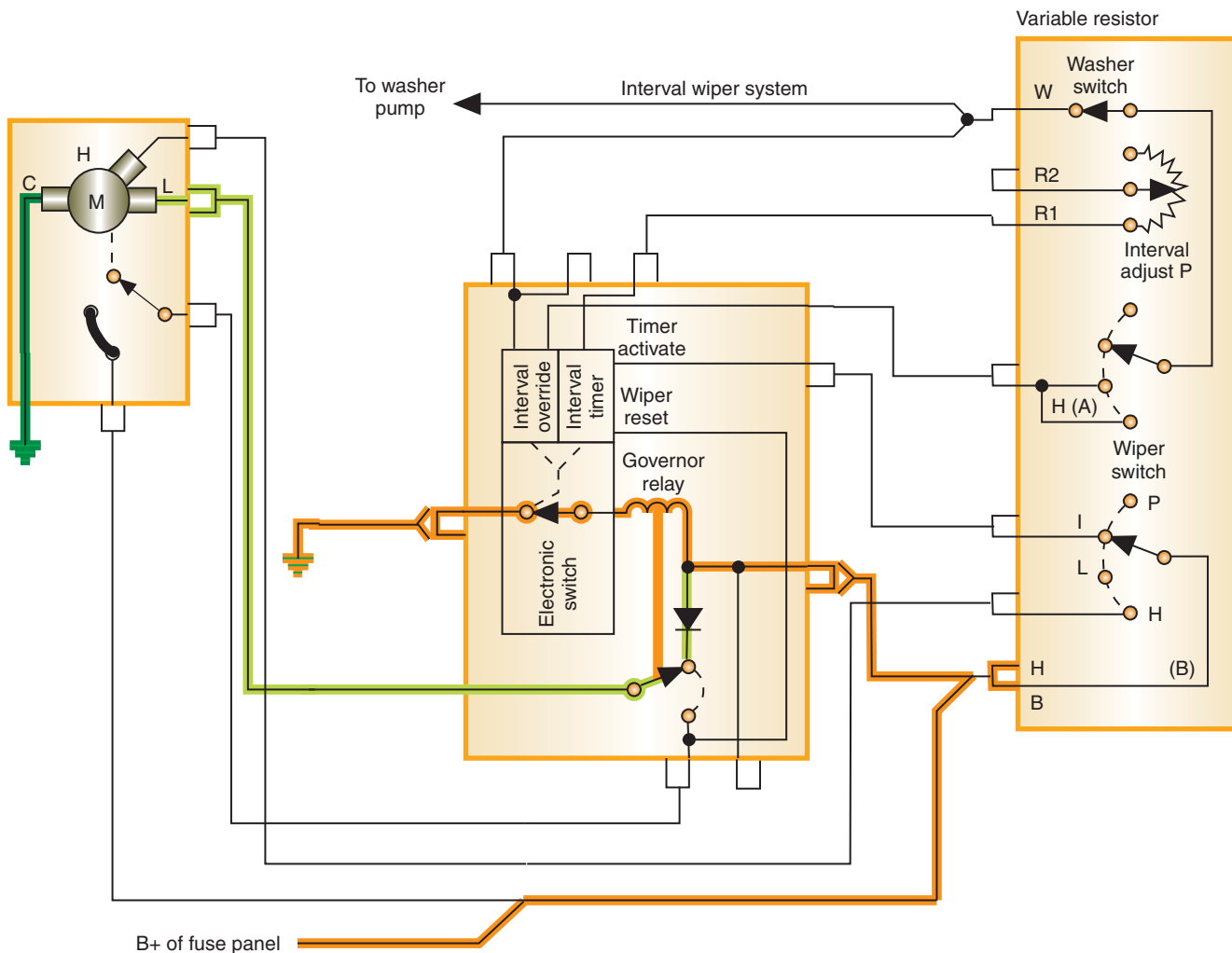


**FIGURE 14-19** Current flow in MEDIUM position.



**FIGURE 14-20** Relay-controlled wiper system.





**FIGURE 14-21** Current flow when intermittent wiper mode is initiated.

© Delmar/Cengage Learning

value is altered. The module contains a capacitor that is charged through the potentiometer. Once the capacitor is saturated, the electronic switch is “triggered” to send current to the wiper motor. The capacitor discharge is long enough to start the wiper operation, and the park switch is returned to the RUN position. The wiper will continue to run until one sweep is completed and the park switch opens. The amount of time between sweeps is based on the length of time required to saturate the capacitor. As more resistance is added to the potentiometer, it takes longer to saturate the capacitor.

**AUTHOR’S NOTE:** Many manufacturers are incorporating this function into the body computer. Also, some manufacturers are equipping their vehicles with speed sensitive wiper systems. The delay between wiper sweeps is determined by the speed of the vehicle.

### Depressed-Park Wiper Systems

Systems that have a depressed-park feature use a second set of contacts with the park switch. These contacts are used to reverse the rotation of the motor for about 15 degrees after the wipers have reached the normal PARK position. The circuitry of the depressed circuit is different from that of standard wiper motors.



Wiper 1 directs the current to the low-speed brush. The ground path is through the common brush, switch wiper 3, and park switch wiper B. This reversed current flow is continued until the wipers reach the depressed-park position, when park switch wiper A swings to the PARKED position.

**AUTHOR'S NOTE:** Note the difference in operation between the depressed-park wiper system and the one shown in Figure 14-14.

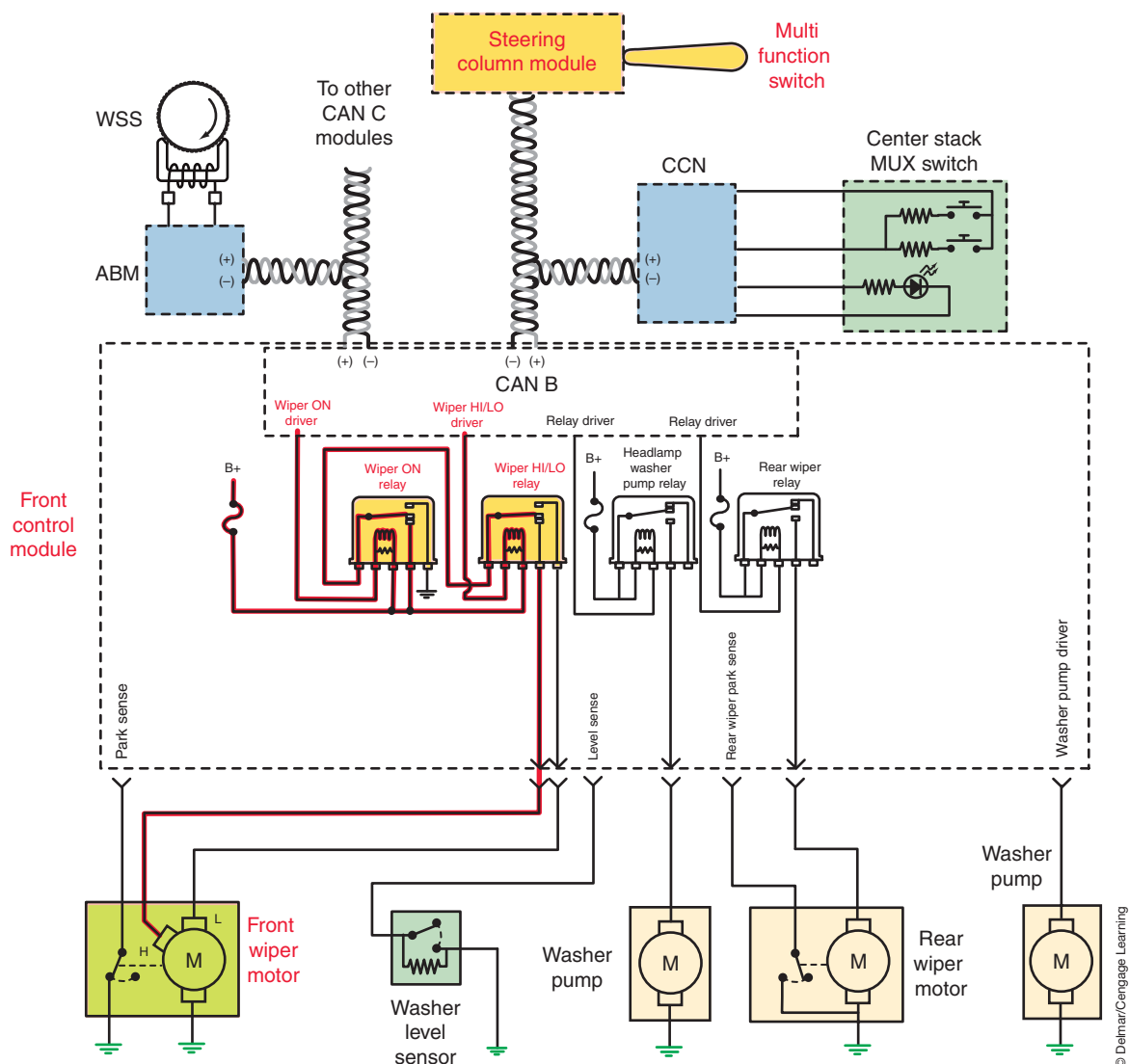
**Shop Manual**

Chapter 14, page 574

**COMPUTER-OPERATED WIPERS**

For much the same reasons has going to computer control of the horn system, manufacturers are also using computers to operate the wiper system (Figure 14-24). In this system, the multifunction switch provides the driver's request for front wiper operation. The steering column module then broadcasts the request over the CAN B bus network to the front control module. This front control module operates the relays by low-side drivers.

The wiper motor is usually a permanent magnet motor. The relays are controlled to provide current to the appropriate brush of the motor. When the LOW speed position of



**FIGURE 14-24** Computer-operated wiper system.

© Delmar/Cengage Learning

the multifunction switch is selected, the steering column module broadcasts a wiper switch LOW message to the front control module. The front control module energizes the wiper ON/OFF relay. This directs battery current through the closed contacts of the energized wiper ON/OFF relay and the normally closed contacts of the de-energized wiper HI/LO relay to the low speed brush of the wiper motor, causing the wipers to cycle at low speed.

When the HIGH speed position is selected, the steering column module broadcasts a wiper switch HIGH message to the front control module. The front control module energizes both the wiper ON/OFF relay and the wiper high/low relay. This directs battery current through the closed contacts of the energized wiper ON/OFF relay and the closed contacts of the energized wiper HI/LO relay to the high speed brush of the wiper motor, causing the wipers to cycle at high speed.

When the OFF position of the multifunction switch is selected, the steering column module sends an electronic wiper switch OFF message to the front control module. Notice that the park switch does not operate the motor; instead it is used as an input. If the wipers are not in the park position on the windshield when the OFF request was broadcast, the front control module keeps the wiper ON/OFF relay energized, until the wiper blades are in the park position as indicated by the park switch input. If the wiper motor was operating at high speed when the OFF request was broadcast, the front control module de-energizes the wiper HI/LO relay, causing the wiper motor to return to low speed operation before parking the wipers.

The computer-controlled wipers system also provides for intermittent wiper operation. When the multifunction switch is moved to one of the intermittent interval positions, the steering column module broadcasts the delay message to the front control module. The front control module uses an intermittent wipe logic circuit that calculates the correct length of time between wiper sweeps based upon the selected delay interval input. The front control module monitors the state of the wiper motor park switch to determine the proper intervals at which to energize and de-energize the wiper ON/OFF relay to operate the wiper motor intermittently for one low speed cycle at a time.

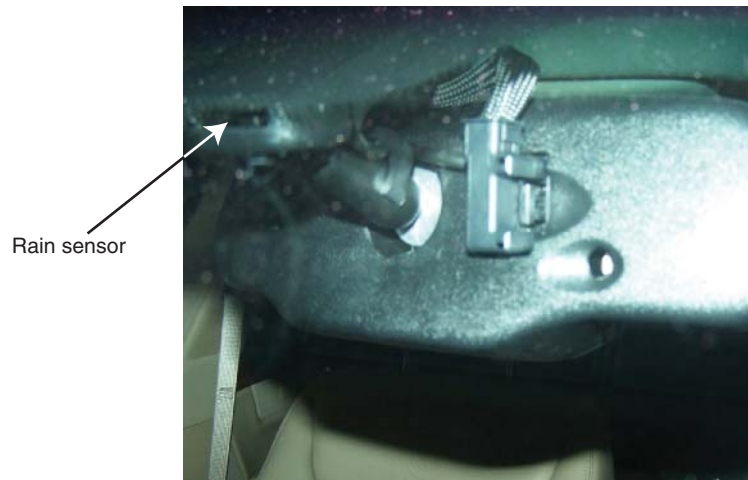
The front control module can also provide vehicle speed sensitivity to the selected intermittent wipe delay intervals. The front control module monitors vehicle speed messages and doubles the selected delay interval whenever the vehicle speed is less than 10 mph (16 kph).

With computer-controlled wiper operation, the driver can select to have the headlights turn on automatically whenever the wipers complete a minimum of five automatic wipe cycles within about sixty seconds. This meets the legal requirements in some states that stipulate the headlights must be turned on whenever the wipers are in use. The headlights will also turn off automatically when the wipers are turned off and four minutes elapse without any wipe cycles.

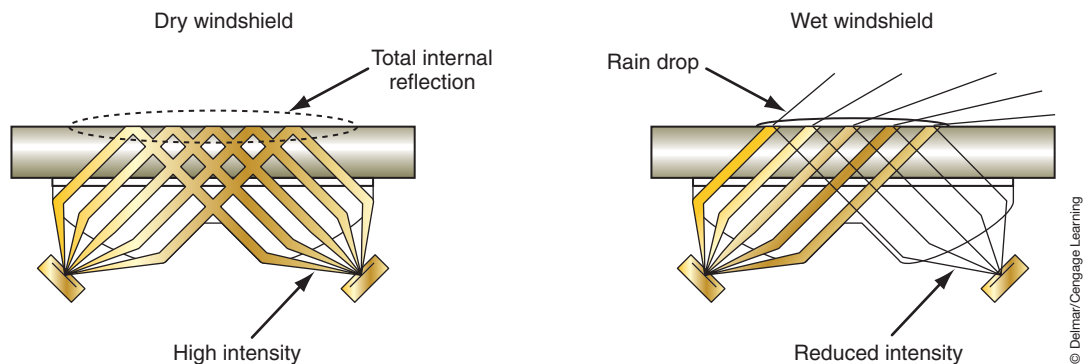
## INTELLIGENT WINDSHIELD WIPERS

To avoid making the driver select the correct speed of the windshield wipers according to the amount of rain, manufacturers have developed intelligent wiper systems. Two intelligent wiper systems will be discussed here: one senses the amount of rainfall and the other adjusts wiper speed according to vehicle speed.

The automatic wiper system selects the wiper speed needed to keep the windshield clear by sensing the presence and amount of rain on the windshield. The system relies on a series of LEDs that shine at an angle onto the inside of the windshield glass and an equal number of light collectors (Figure 14-25). The outer surface of a dry windshield will reflect the lights from the LEDs back into a series of collectors. The presence of water on the windshield will refract some of the light away from the collectors (Figure 14-26). When this happens, the wipers are turned on. If the water is not cleared by one complete travel of the wipers, the wipers



**FIGURE 14-25** The rain sensor is mounted to the rearview mirror.



**FIGURE 14-26** The light beams are deflected when water is on the windshield.

operate again. The frequency and speed of wiper operation is determined by the amount of water sensed on the windshield.

Speed-sensitive wipers do not require additional components to operate since most use the BCM. Speed-sensitive wipers compensate for extra moisture that normally accumulates on the windshield at higher speeds in the rain. At higher speeds, the delay between wipers shortens when the wipers are operating in the interval mode. This delay is automatically adjusted at speeds between 10 and 65 miles per hour. Basically, this system functions according to the input the computer receives about vehicle speed.

### Shop Manual

Chapter 14, page 579

The washer system includes plastic or rubber hoses to direct fluid flow to the nozzles and produce the spray pattern.

## WASHER PUMPS

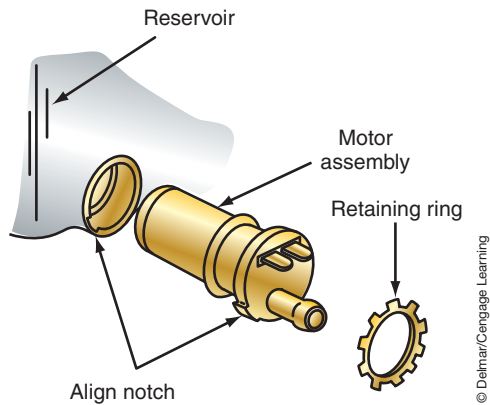
Windshield washers spray a washer fluid solution onto the windshield and work in conjunction with the wiper blades to clean the windshield of dirt. Some vehicles that have composite headlights incorporate a headlight washing system along with the windshield washer (Figure 14-27). Most systems have the washer pump motor installed into the reservoir (Figure 14-28). General Motors uses a pulse-type washer pump that operates off the wiper motor (Figure 14-29).

The system is activated by holding the washer switch (Figure 14-30). If the wiper/washer system also has an intermittent control module, a signal is sent to the module when the washer switch is activated (Figure 14-31). An override circuit in the module operates the wipers on low speed for a programmed length of time. The wipers either will return to the parked position or will operate in intermittent mode, depending on system design.



© Delmar/Cengage Learning

**FIGURE 14-27** Headlight washer system may operate with the windshield washer or have a separate switch.



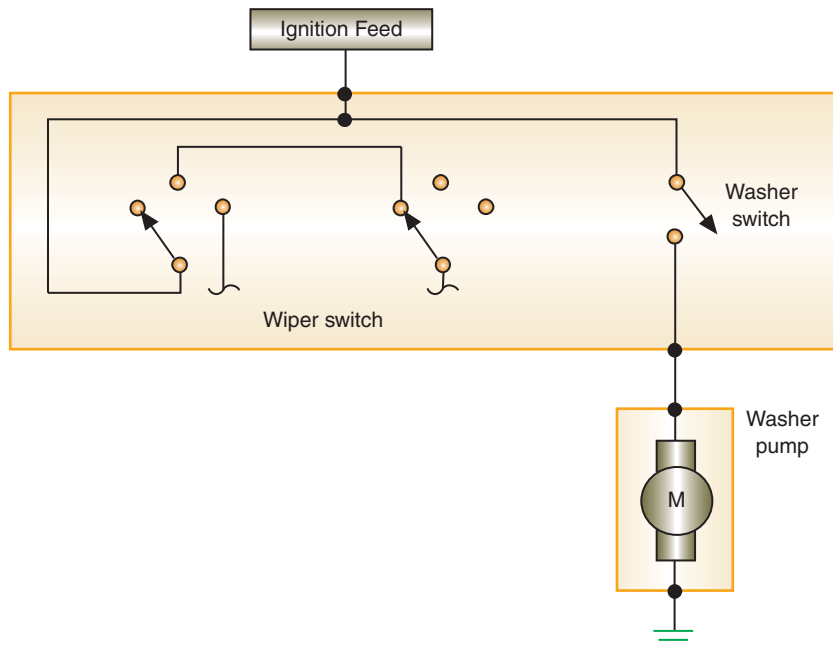
© Delmar/Cengage Learning

**FIGURE 14-28** Washer motor installed into the reservoir.



© Delmar/Cengage Learning

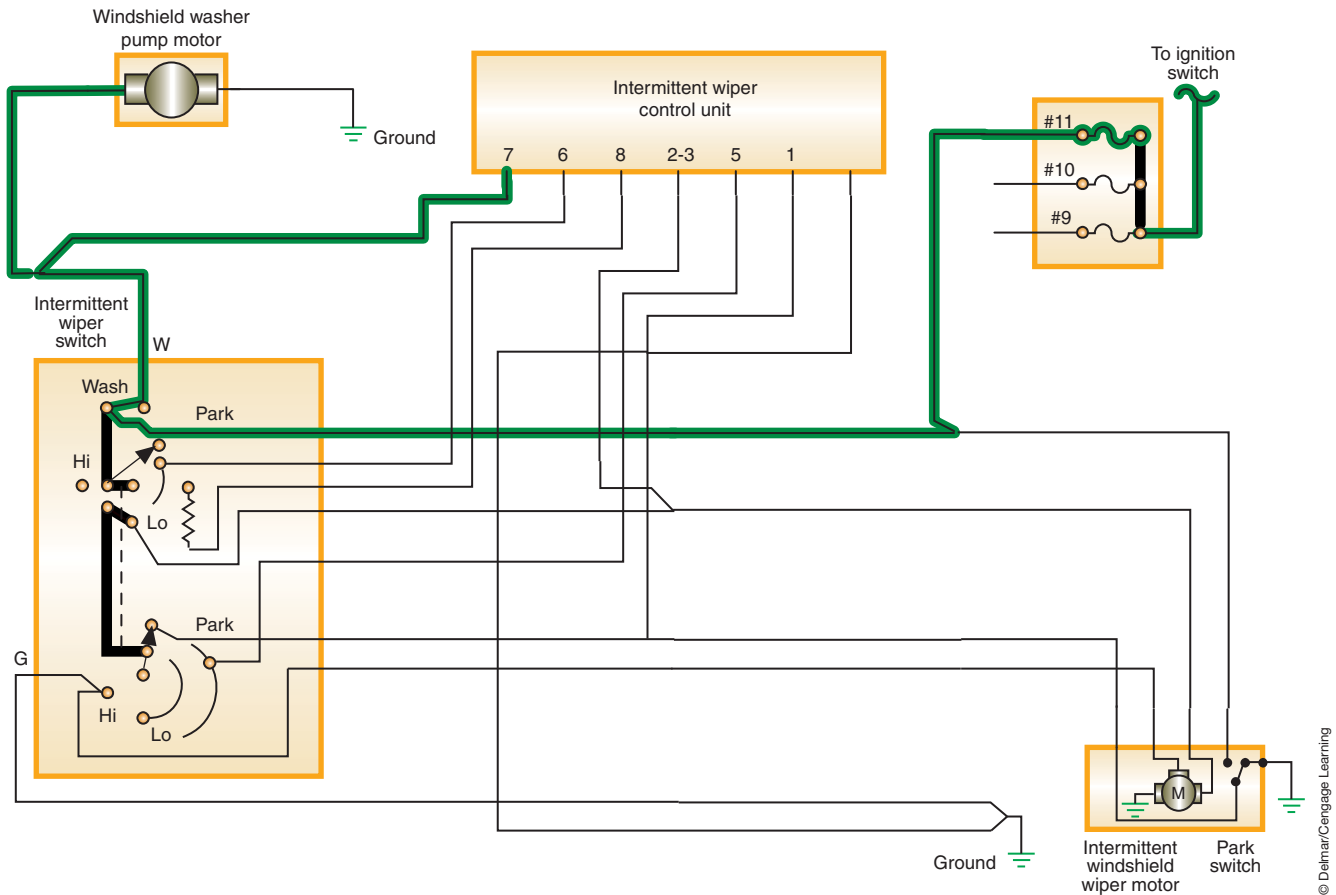
**FIGURE 14-29** General Motors' pulse-type washer system incorporates the washer motor into the wiper motor.



© Delmar/Cengage Learning

**FIGURE 14-30** Windshield washer motor circuit.





**FIGURE 14-31** Input signal alerts the module that the washers are activated.

## Computer-Operated Wiper Systems

Referring to Figure 14-37, when the WASH request is made by depressing the control knob on the control stalk of the multifunction switch, the steering column module broadcasts a washer switch message to the front control module over the CAN B bus. The front control module then uses an H-gate driver circuit that directs battery current and ground to the washer pump. At the same time, the wipers are turned on and operate for about three wipes.

**AUTHOR'S NOTE:** The H-gate driver is used in this instance since the vehicle is also equipped with a rear window wiper system. This system uses only one washer pump. Based on the direction of current flow through the pump, the washer fluid will be directed to either the front windshield or the rear window.

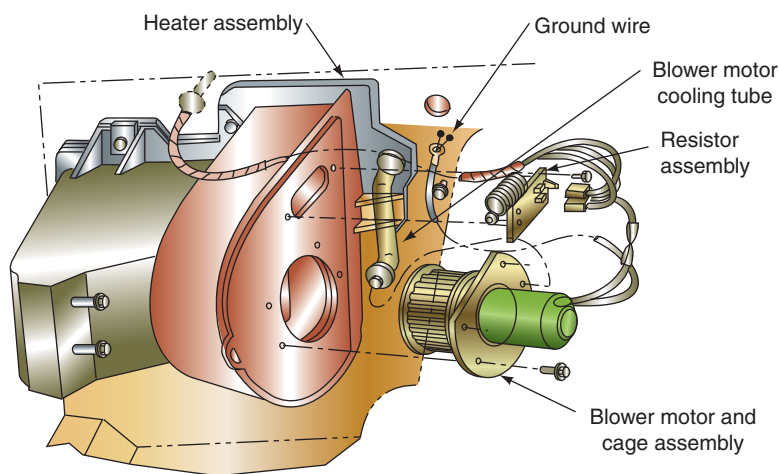
If wash is requested while the wipers are already turn and operating in one of the intermittent interval positions, the washer pump operation is the same. However, during this time the front control module will abort the delay feature and will energize the wiper ON/OFF relay to operate the wiper motor in a continuous low-speed mode for as long as the WASH switch is closed. When the wash request is no longer present, the front control module will resume the selected delay mode interval.

The headlamp washer system uses a separate high-pressure pump that is activated when the headlamps are turned on and the windshield washer switch is closed. This will operate the windshield washers and direct two-timed high pressure sprays onto the headlamp lens.

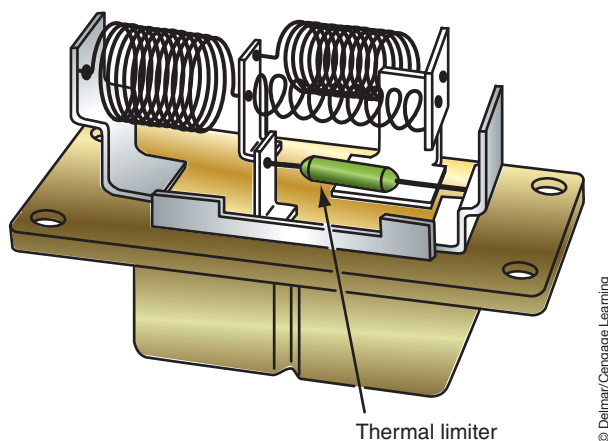
## BLOWER MOTOR CIRCUITS

The blower motor is used to move air inside the vehicle for air conditioning, heating, defrosting, and ventilation. The motor is usually a permanent magnet, single-speed motor and is located in the heater housing assembly (Figure 14-32). A blower motor switch mounted on the dash controls the fan speed. The switch position directs current flow to a **resistor block** that is wired in series between the switch and the motor (Figure 14-33) and consists of two or three helically wound wire resistors wired in series.

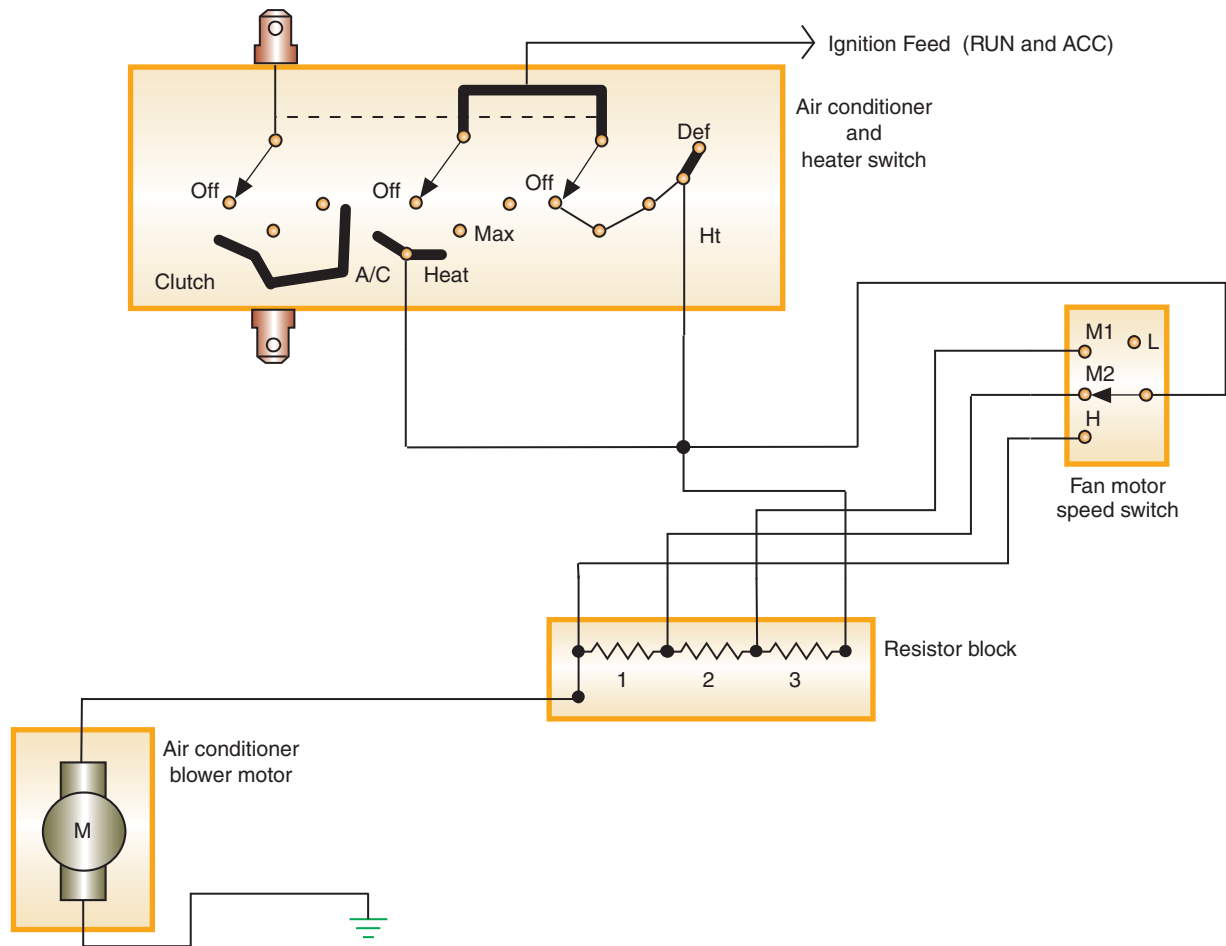
The blower motor circuit includes the control assembly, blower switch, resistor block, and blower motor (Figure 14-34). This system uses an insulated side switch and a grounded motor. Battery voltage is applied to the control head when the ignition switch is in the RUN or ACC positions. The current can flow from the control head to the blower switch and resistor block in any control head position except OFF.



**FIGURE 14-32** The blower motor is usually installed into the heater assembly. Mode doors control if vent, heater, or A/C-cooled air is blown by the motor cage.



**FIGURE 14-33** Fan motor resistor block.



**FIGURE 14-34** Blower motor circuit.

© Delmar/Cengage Learning

When the blower switch is in the LOW position, the blower switch wiper opens the circuit. Current can only flow to the resistor block directly through the control head. The current must pass through all the resistors before reaching the motor. With the voltage dropped over the resistors, the motor speed is slowed (Figure 14-35).

When the blower switch is placed in the MED 1, MED 2, or HIGH position, the current flows through the blower switch to the resistor block. Depending on the speed selection, the current must pass through one, two, or none of the resistors. With more applied voltage to the motor, the fan speed is increased as the amount of resistance decreases.

Current through the circuit will remain constant; varying the amount of resistance changes the voltage applied to the motor. Because the motor is a single-speed motor, it obtains its fastest rotational speed with full battery voltage. The resistors drop the amount of voltage to the motor, resulting in slower speeds.

Some manufacturers use ground side switching with an insulated motor (Figure 14-36). The switch completes the circuit to ground. Depending on wiper position, current flow is directed through the resistor block. The operating principles are identical to that of the insulated switch already discussed.

**AUTHOR'S NOTE:** Many of today's vehicles are using the body computer to control fan speed by pulse width modulation.



### A BIT OF HISTORY

Automotive electric heaters were introduced at the 1917 National Auto Show. Hot water in-car heaters were introduced in 1926.

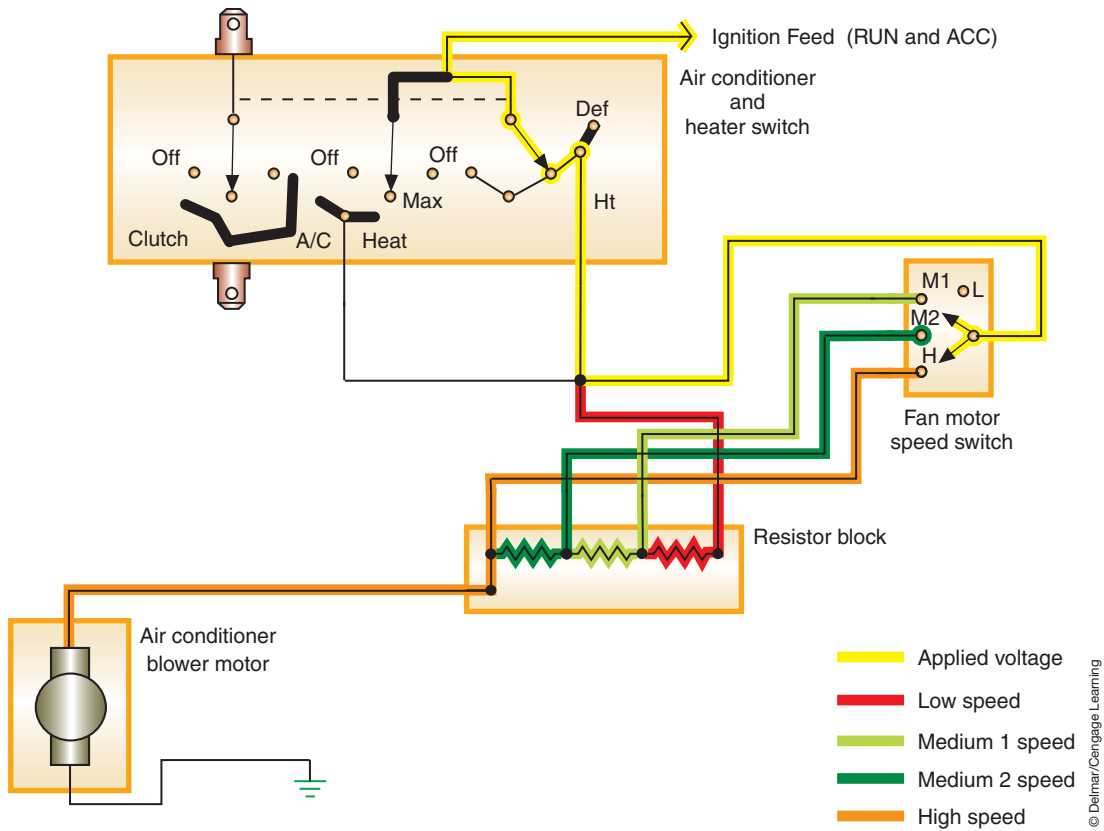


FIGURE 14-35 Current flow in the different speed selections.

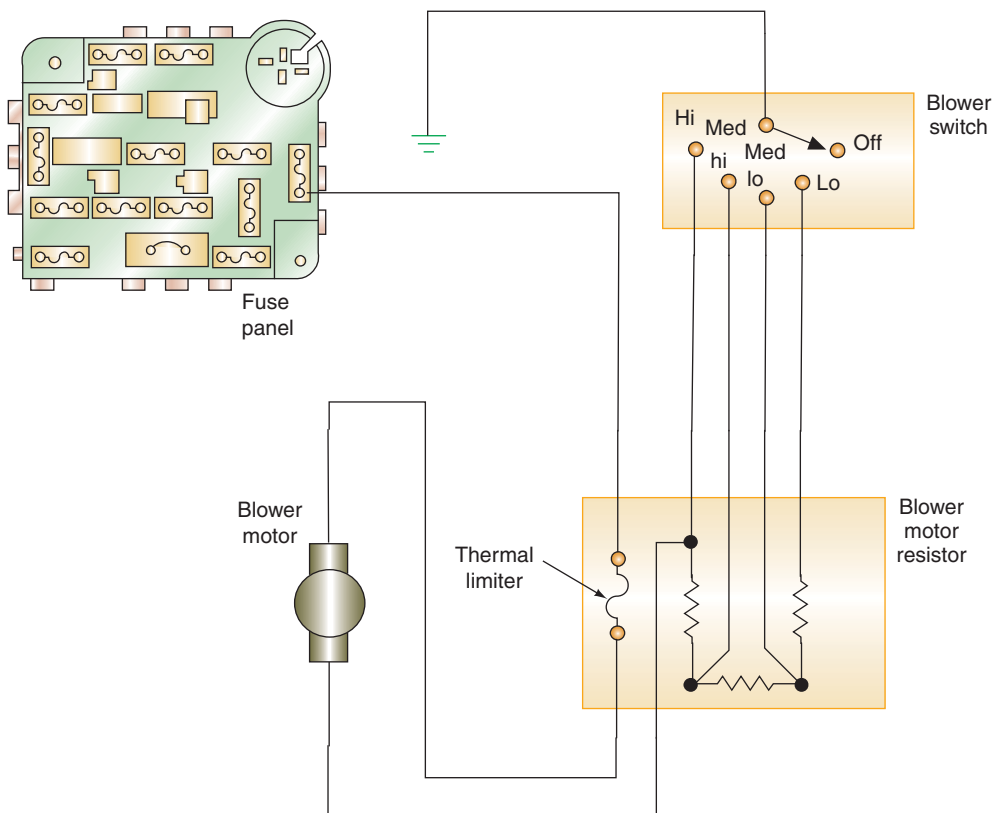


FIGURE 14-36 Ground side switch to control the blower motor system.

## ELECTRIC DEFOGGERS

When electrons are forced to flow through a resistance, heat is generated. Rear window electric defoggers use this principle of controlled resistance to heat the glass. Electric defoggers heat the rear window to remove ice and/or condensation. Some vehicles use the same circuit to heat the outside driver's side mirror. The resistance is through a **grid** that is baked on the inside of the glass (Figure 14-37). The rear window defogger grid is a series of horizontal, ceramic silver-compounded lines baked into the surface of the window. The terminals are soldered to the vertical bus bars. One terminal supplies the current from the switch; the other provides the ground (Figure 14-38).

Most systems incorporate a timer circuit to control the relay (Figure 14-39). The timer is used due to the high amount of current required to operate the system (approximately 30 amperes). If this drain were allowed to continue for extended periods of time, battery and charging system failure could result. Because of the high current draw, most vehicles equipped with a rear window defogger use a high output AC generator.

The control switch may be a three-position, spring-loaded switch that returns to the center position after making momentary contact to the ON or OFF terminals. Activation of the switch energizes the electronic timing circuit, which energizes the relay coil. With the relay contacts closed, direct battery voltage is sent to the heater grid. At the same time, voltage is applied to the ON indicator. The timer is activated for 10 minutes. At the completion of the timed cycle, the relay is de-energized and the circuit to the grid and indicator light is broken. If the switch is activated again, the timer will energize the relay for 5 minutes.

The ON indicator can be either a bulb or light-emitting diode (LED).



FIGURE 14-37 Rear window defogger grid.

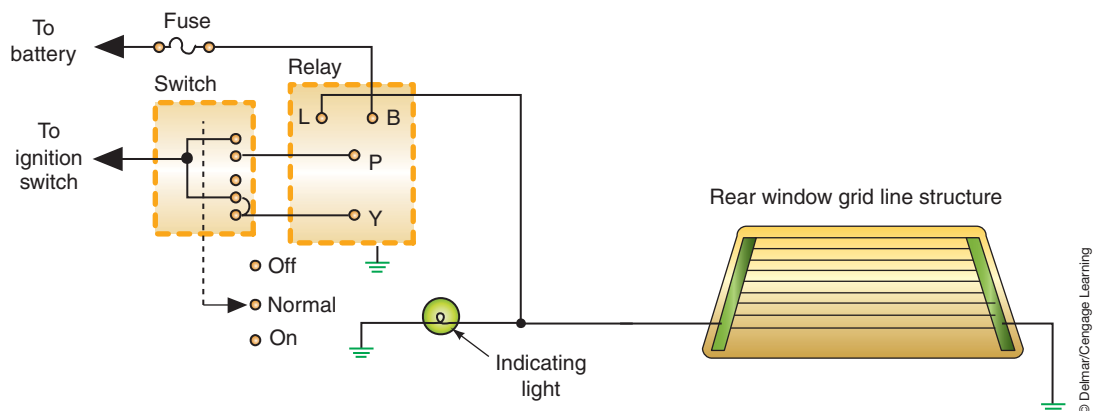
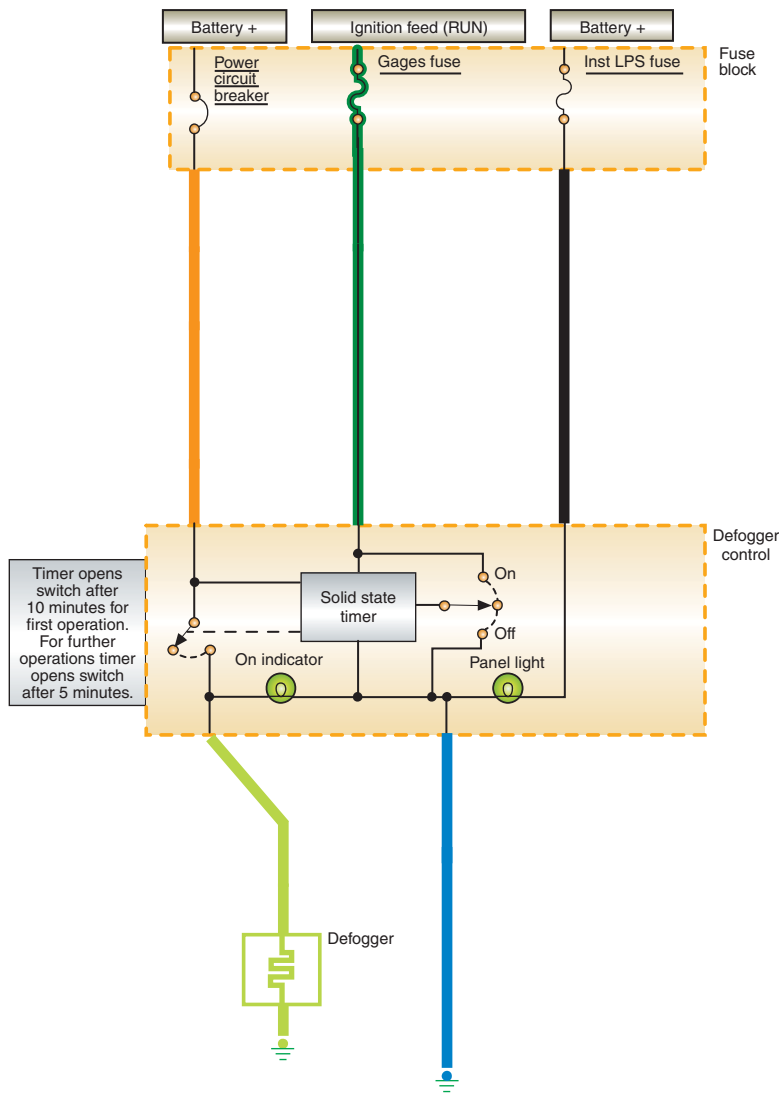


FIGURE 14-38 Rear window defogger circuit schematic.



**FIGURE 14-39** Defogger circuit using a solid-state timer.

© Delmar/Cengage Learning

The timer sequence can be aborted by moving the switch to the OFF position or by turning off the ignition switch. If the ignition switch is turned off while the timer circuit is activated, the rear window defogger switch will have to be returned to the ON position to activate the system again.

Ambient temperatures have an effect on electrical resistance; thus the amount of current flow through the grid depends on the temperature of the grid. As the ambient temperature decreases, the resistance value of the grid also decreases. A decrease in resistance increases the current flow and results in quick warming of the window. The defogger system tends to be self-regulated to match the requirements for defogging.

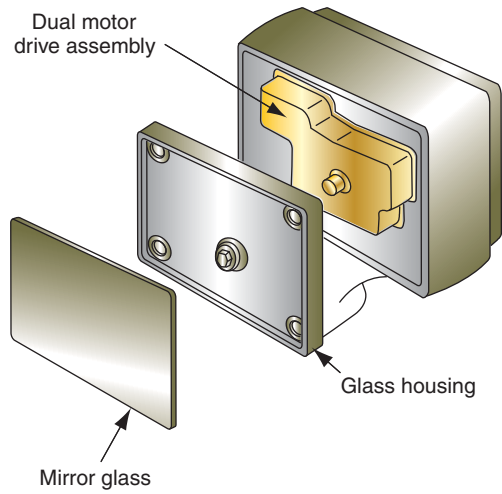
## POWER MIRRORS

Electrically controlled power mirrors allow the driver to position the outside mirrors by use of a switch. The mirror assembly will use built-in, dual drive, reversible permanent magnet (PM) motors (Figure 14-40).

A single switch for controlling both the left and right side mirrors is used. On many systems, selection of the mirror to be adjusted requires positioning a switch. After the mirror is selected, movement of the power mirror switch (up, down, left, or right) moves the mirror in the corresponding direction. The illustration (Figure 14-41) shows a logic table for the mirror switch and motors.

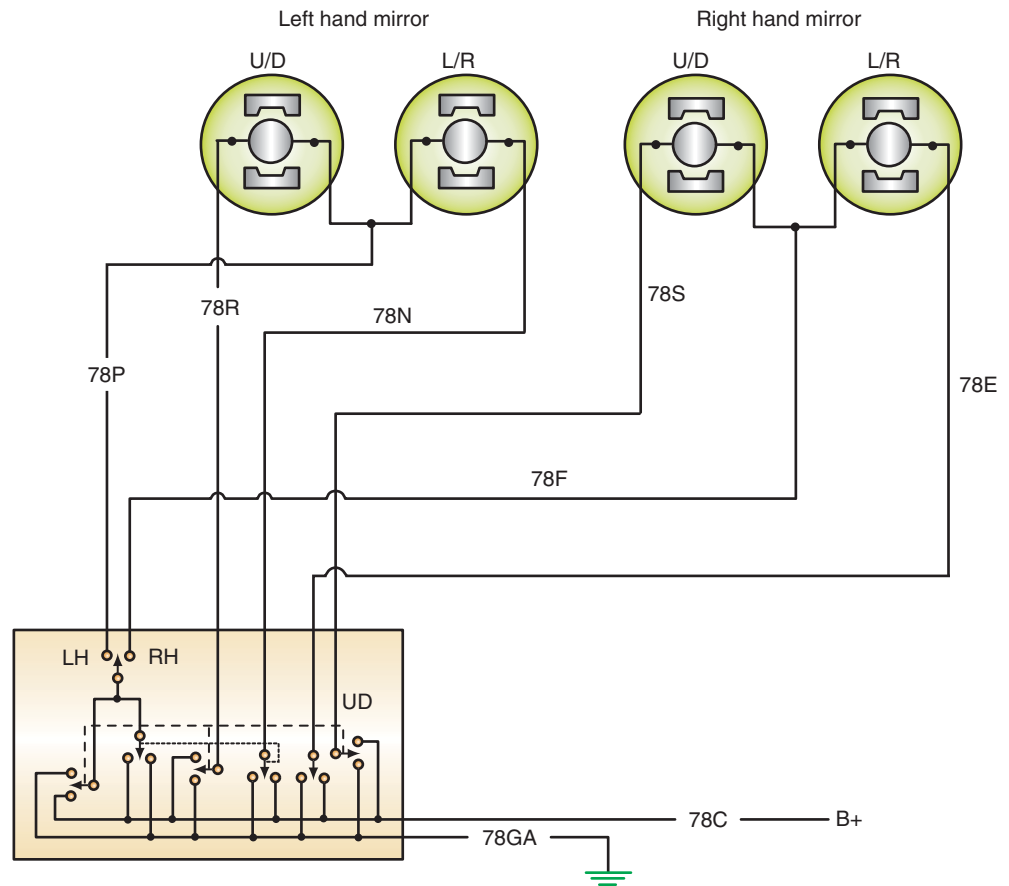
Many manufacturers refer to the electric rear window defogger as an electric backlight (EBL).





© Delmar/Cengage Learning

**FIGURE 14-40** Power mirror motor.



Switch function	Circuit function	
	Left mirror	Right mirror
Left	(78P+78C)(78N+78GA)	(78F+78C)(78E+78GA)
Right	(78N+78C)(78P+78GA)	(78E+78C)(78F+78GA)
Up	(78R+78C)(78P+78GA)	(78S+78C)(78F+78GA)
Down	(78P+78C)(78R+78GA)	(78F+78C)(78S+78GA)

**FIGURE 14-41** Power mirror logic table.

© Delmar/Cengage Learning

## Automatic Rearview Mirror

Some manufacturers have developed interior rearview mirrors that automatically tilt when the intensity of light that strikes the mirror is sufficient enough to cause discomfort to the driver.

The system has two photocells mounted in the mirror housing. One of the photocells is used to measure the intensity of light inside the vehicle. The second is used to measure the intensity of light the mirror is receiving. When the intensity of the light striking the mirror is greater than that of ambient light, by a predetermined amount, a solenoid is activated that tilts the mirror.

## Electrochromic Mirrors

**Electrochromic mirrors** automatically adjust the amount of reflectance based on the intensity of glare (Figure 14-42). The electrochromic mirror uses forward- and rearward-facing photo sensors and a solid-state chip. Based on light intensity differences, the chip applies a small voltage to the silicon layer. As voltage is applied, the molecules of the layer rotate and redirect the light beams. Thus the mirror reflection appears dimmer. If the glare is heavy, the mirror darkens to about 6% reflectivity. The electrochromic mirror has the advantage that it provides a comfort zone where the mirror will provide 20% to 30% reflectivity. When no glare is present, the mirror changes to the daytime reflectivity rating of up to 85%. The reduction of the glare by darkening of the mirror does not impair visibility.

Electrochromic mirrors can be installed as the outside mirror and/or inside mirrors. The mirror is constructed of a thin layer of electrochromic material that is placed between two plates of conductive glass. There are two photocell sensors that measure light intensity in front and in back of the mirror. During night driving, the headlight beam striking the mirror causes the mirror to gradually become darker as the light intensity increases. The darker mirror absorbs the glare. Some systems allow for sensitivity of the mirror to be adjusted by the driver through a three-position switch (Figure 14-43).

When the ignition switch is placed in the RUN position, battery voltage is applied to the three-position switch. If the switch is in the MIN position, battery voltage is applied to the solid-state unit and sets the sensitivity to a low level. The MAX setting causes the mirror to darken more at a lower glare level. When the transmission is placed in reverse, the reset circuit is activated. This returns the mirror to daytime setting for clearer viewing to back up.

The MIN position is used for city driving.



FIGURE 14-42 Electrochromic mirror operation (A) Day time; (B) Mild glare; (C) High glare.

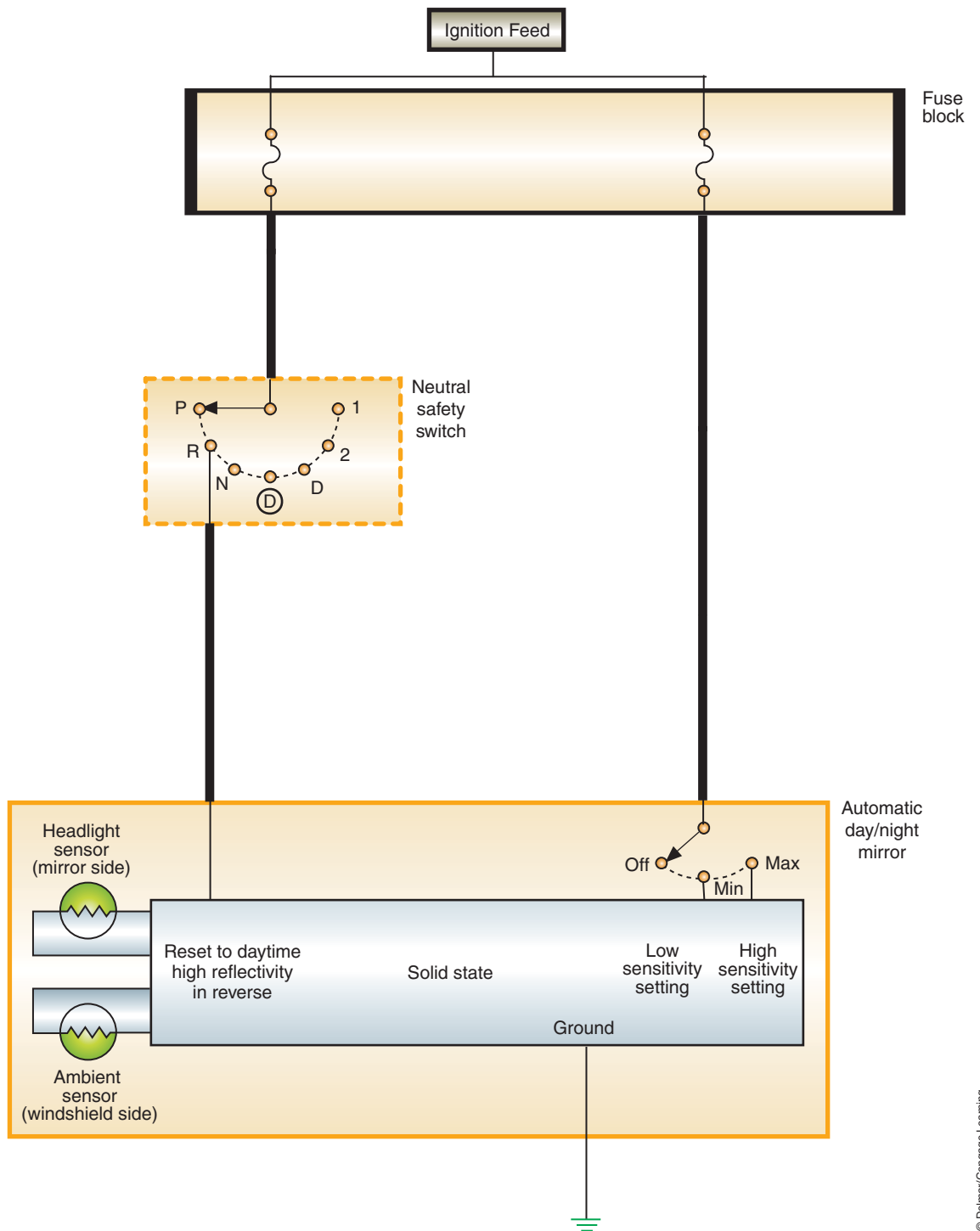


FIGURE 14-43 Automatic electrochromic day/night mirror diagram.

© Delmar/Cengage Learning

**Shop Manual**  
Chapter 14, page 587

## POWER WINDOWS

Most vehicle manufacturers have replaced the conventional window crank with electric motors that operate the side windows. In addition, most sport utility models are equipped with electric rear tailgate windows. The motor used in the power window system is a reversible PM or two-field winding motor.

**The power window system usually consists of the following components:**

1. Master control switch.
2. Individual control switches.
3. Individual window drive motors.
4. Lock-out or disable switch.

Another design is to use rack-and-pinion gears. The rack is a flexible strip of gear teeth with one end attached to the window (Figure 14-44).

A **window regulator** converts the rotary motion of the motor into the vertical movement of the window. The motor operates the window regulator either through a cable or directly. On direct drive motors, the motor pinion gear meshes with gear teeth on the regulator called the **sector gear** (Figure 14-45). As the window is lowered, the spiral spring is wound. The spring unwinds as the window is raised, to assist in raising the window. The spring reduces the amount of current that would be required to raise the window by the motor itself.

The master control switch provides the overall control of the system (Figure 14-46). Power to the individual switches is provided through the master switch. The master switch may also have a safety lock switch to prevent operation of the windows by the individual switches. When the safety switch is activated, it opens the circuit to the other switches and control is only by the master switch. As an additional safety feature, some systems prevent operation of the individual switches unless the ignition switch is in the RUN or ACC position.

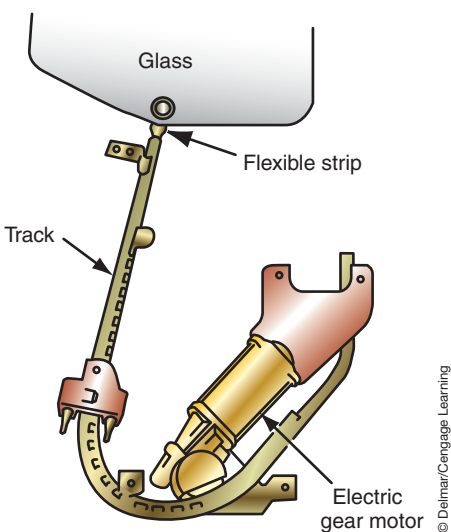
Wiring circuits depend on motor design. Most PM-type motors are insulated, with ground provided through the master switch (Figure 14-47). When the master control switch is placed in the UP position, current flow is from the battery, through the master switch wiper, through the individual switch wiper, to the top brush of the motor. Ground is through the bottom brush and circuit breaker to the individual switch wiper, to the master switch wiper and ground.

When the window is raised from the individual switch, battery voltage is supplied directly to the switch and wiper from the ignition switch. The ground path is through the master control switch.

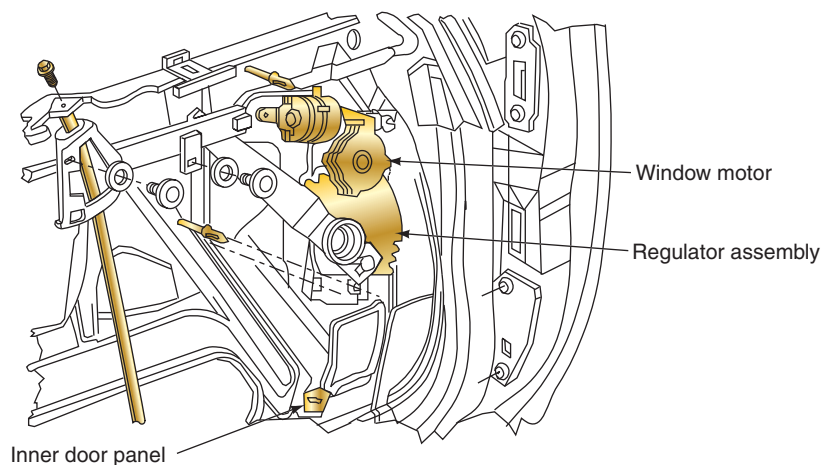


## A BIT OF HISTORY

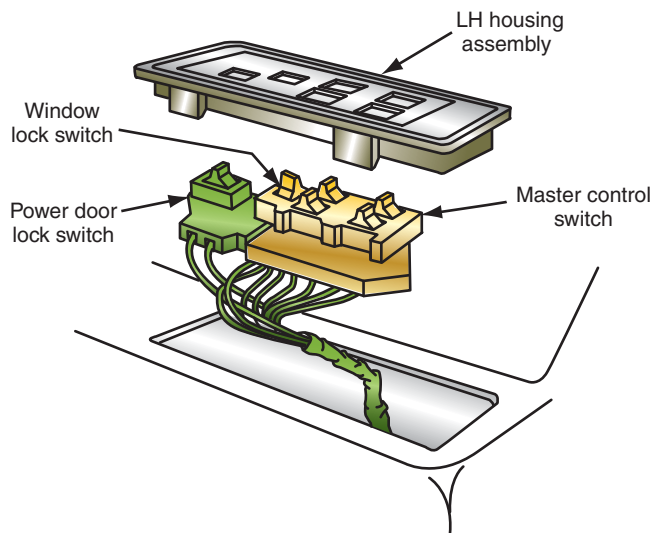
Power windows were introduced in 1939.



**FIGURE 14-44** Rack-and-pinion-style power window motor and regulator.

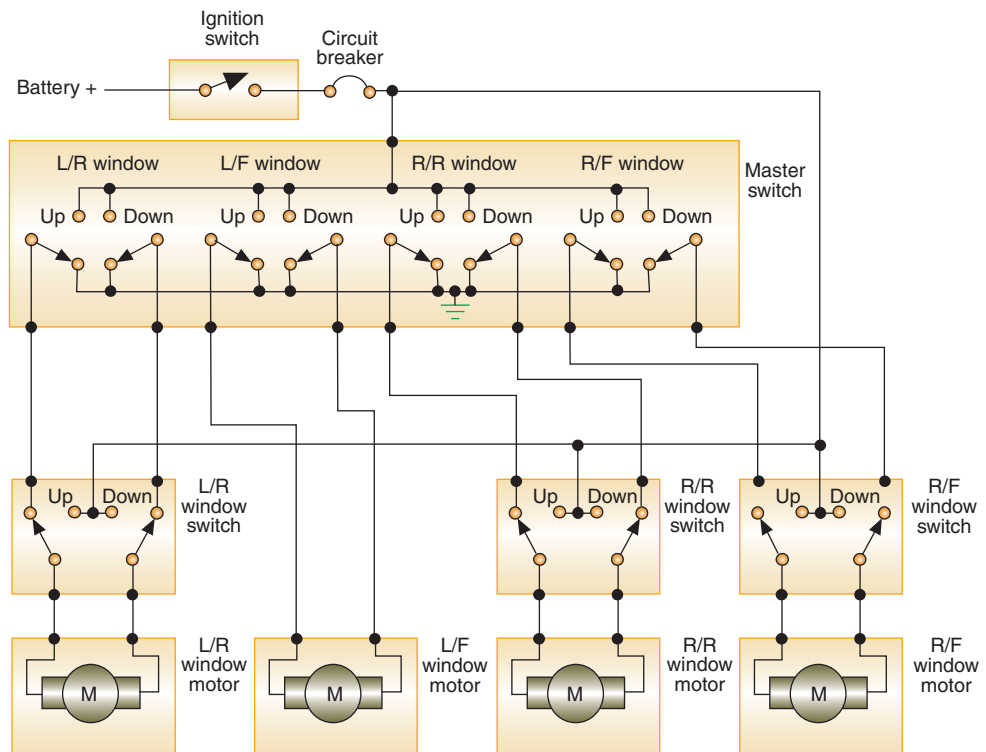


**FIGURE 14-45** Window regulator.



© Delmar/Cengage Learning

**FIGURE 14-46** Power window master control switch.

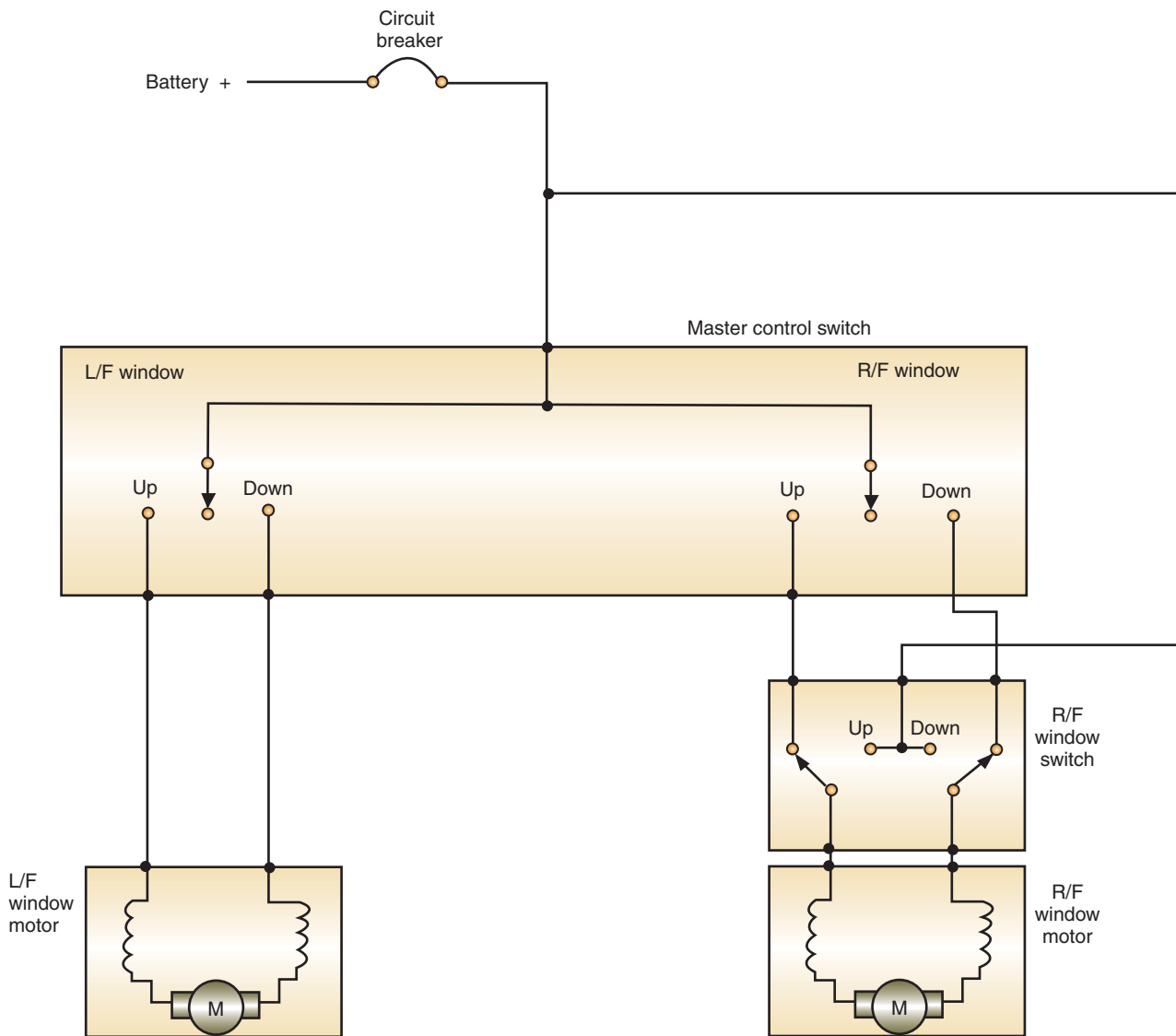


© Delmar/Cengage Learning

**FIGURE 14-47** Typical power window circuit using PM motors.

When the window is lowered from the master control switch, the current path is reversed. In the illustration shown, current flows through the individual switch to lower the window.

Some manufacturers use a two-field coil motor that is grounded with insulated side switches. The two field coils are wired in opposite directions and only one coil is energized at a time. Direction of the motor is determined by which coil is activated (Figure 14-48).



© Delmar/Cengage Learning

FIGURE 14-48 Wiring diagram of power window circuit using two-field coil motors.

## POWER SEATS

The power seat system is classified by the number of ways in which the seat is moved. The most common classifications are:

1. Two-way: Moves the seat forward and backward.
2. Four-way: Moves the seat forward, backward, up, and down.
3. Six-way: Moves the seat forward, backward, up, down, front tilt, and rear tilt.

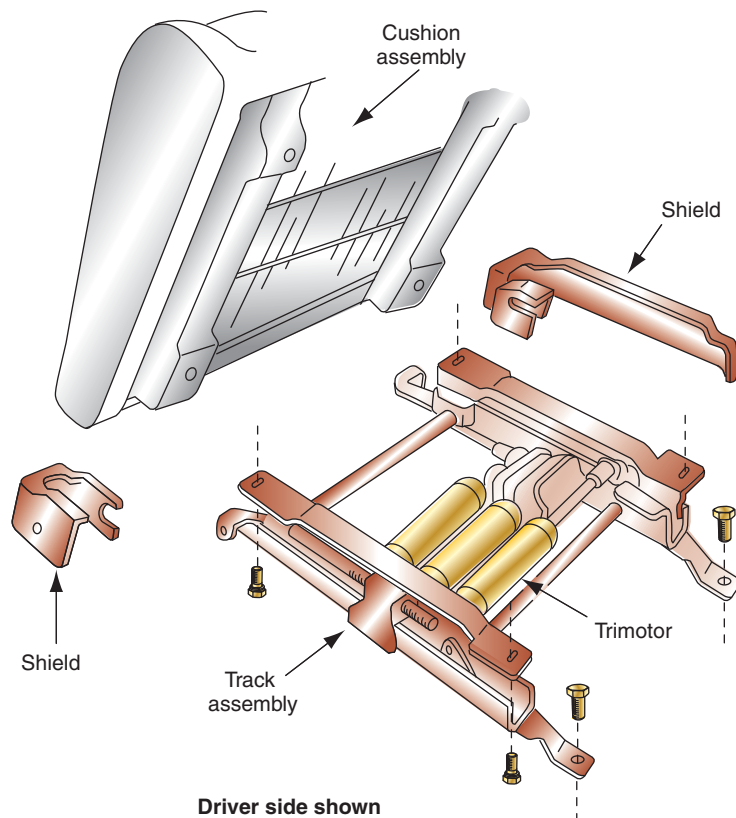
All modern six-way power seats use a reversible, permanent magnet, three-armature motor called a **trimotor** (Figure 14-49). The motor may transfer rotation to a rack-and-pinion or to a worm gear drive transmission. A typical control switch consists of a four-position knob and a set of two-position switches (Figure 14-50). The four-position knob controls the forward, rearward, up, and down movement of the seat. The separate two-position switches are used to control the front tilt and rear tilt of the seat.

### Shop Manual

Chapter 14, page 589

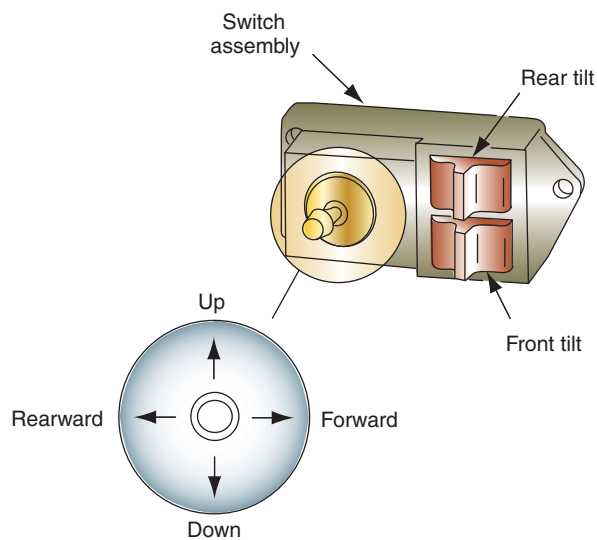
Some seat back latches use a solenoid to lock the seat unless the door is open. The solenoid is controlled by the door jamb switch.





**FIGURE 14-49** Trimotor power seat installation.

© Delmar/Cengage Learning

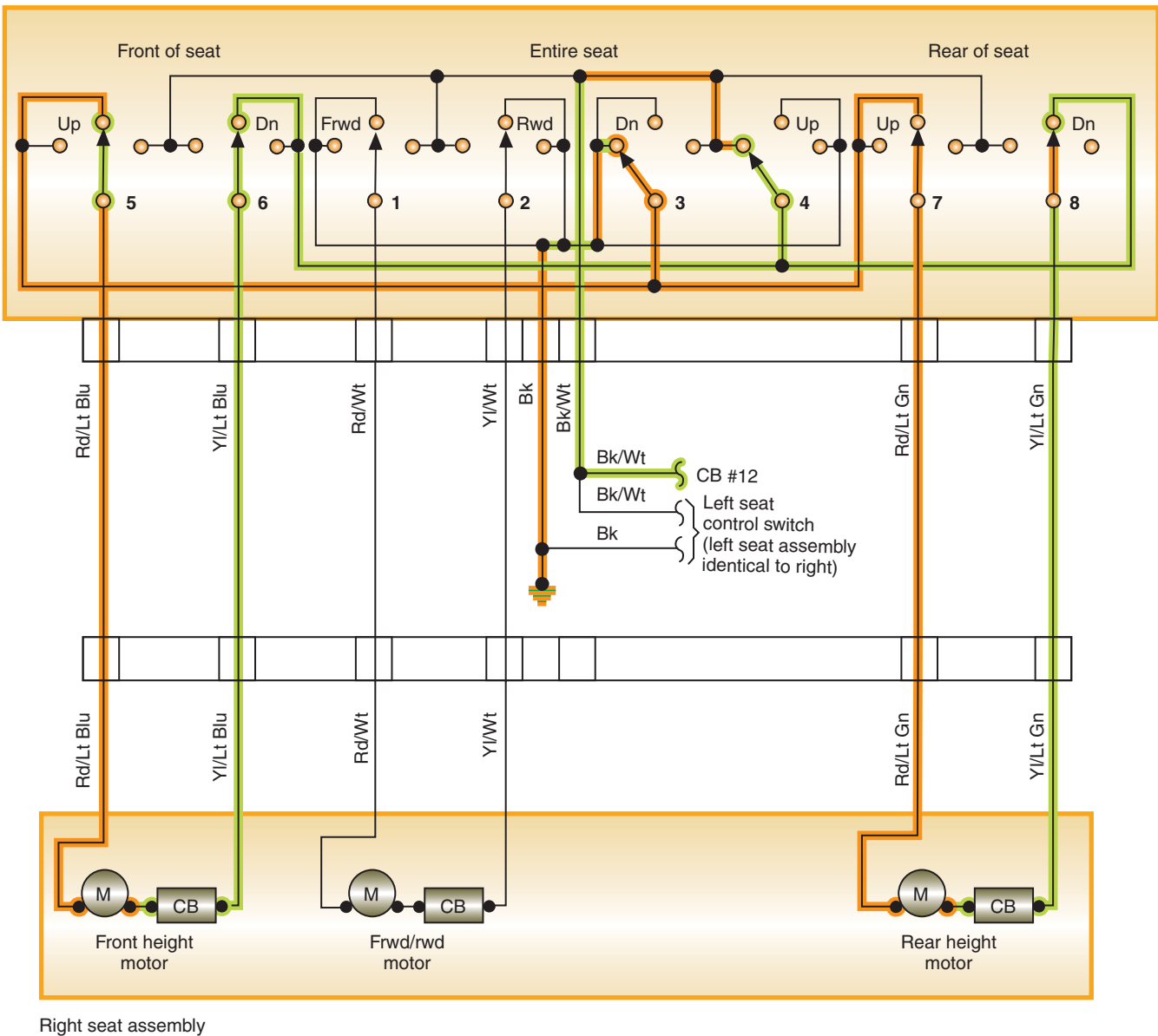


**FIGURE 14-50** Power seat control switch.

© Delmar/Cengage Learning

**AUTHOR'S NOTE:** Early General Motors six-way power seats used a single motor. Solenoids were used to connect the motor to one of three transmissions that would move the seat.

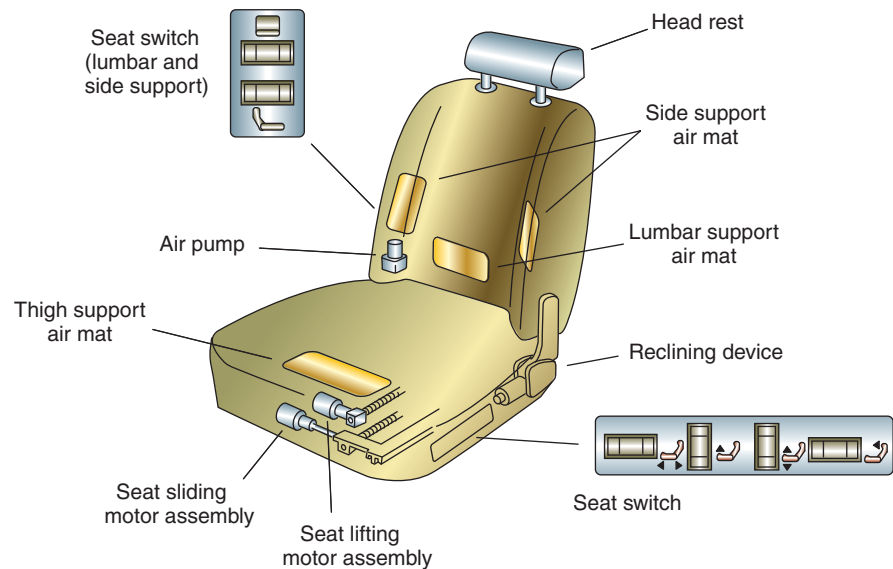
Right seat control switch



**FIGURE 14-51** Current flow in the seat LOWER position.

Current direction through the motor determines the rotation direction of the motor. The switch wipers control the direction of current flow. If the driver pushes the four-way switch into the down position, the entire seat lowers (Figure 14-51). Switch wipers 3 and 4 are swung to the left and battery voltage is sent through wiper 4 to wipers 6 and 8. These wipers direct the current to the front and rear height motors. The ground circuit is provided through wipers 5 and 7, to wiper 3 and ground.

Some manufacturers equip their seats with adjustable support mats that shape the seat to fit the driver (Figure 14-52). The lumbar support mat provides the driver with additional comfort by supporting the back curvature. Some systems use air that is pumped into the mats; others use a motor to roll the lumbar support.



**FIGURE 14-52** Adjustable seat cushions increase drive comfort and safety.

**Shop Manual**

Chapter 14, page 589

## MEMORY SEATS

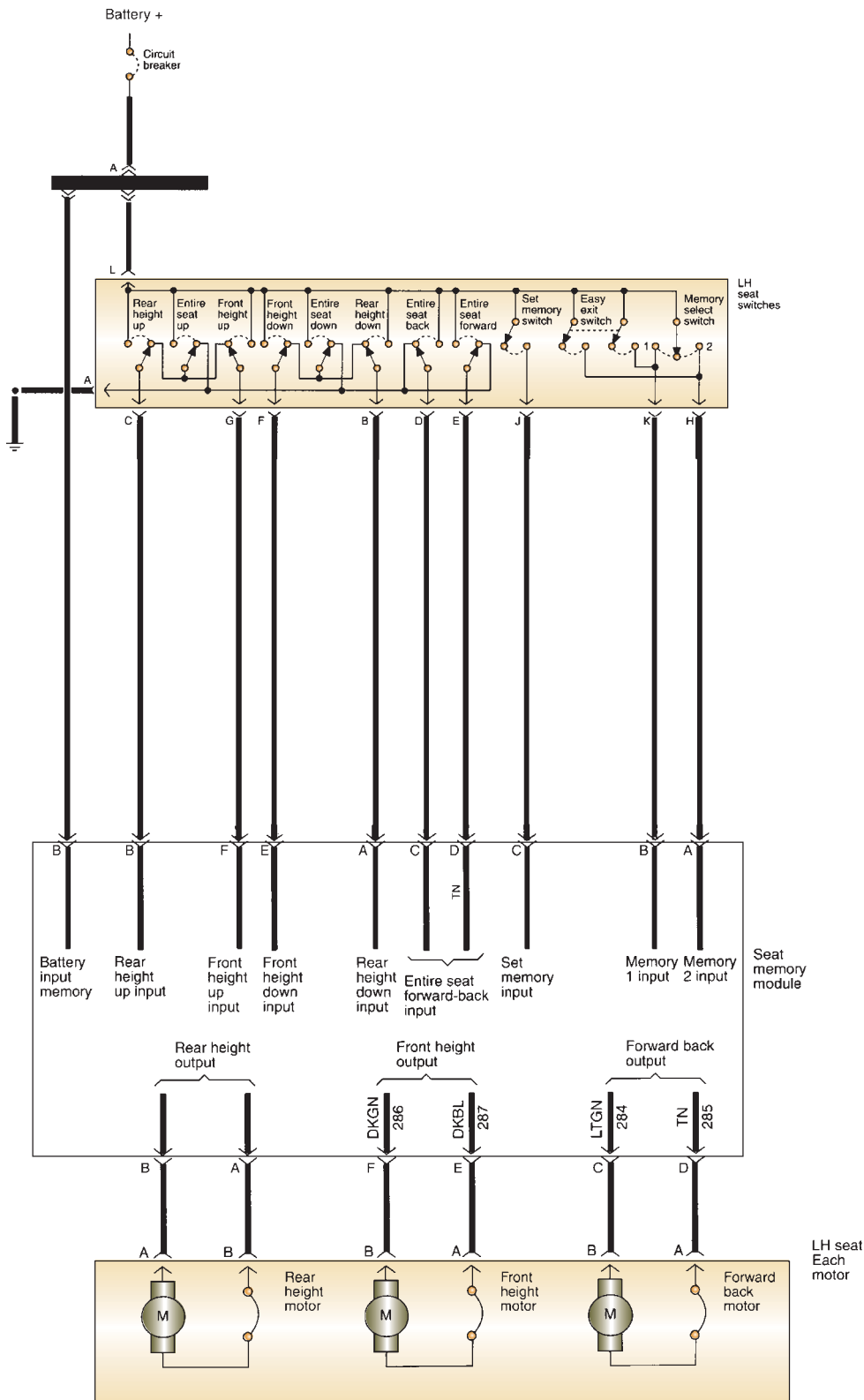
The memory seat feature is an addition to the basic power seat system that allows the driver to program different seat positions that can be recalled at the push of a button. Most memory seat systems share the same basic operating principles. The difference is in programming methods and the number of positions that can be programmed.

The power seat system may operate in any gear position. However, the memory seat function will operate only when the transmission is in the PARK position. The purpose of the memory disable feature is to prevent accidental seat movement while the vehicle is being driven. In the PARK position, the seat memory module will receive a 12-volt signal that will enable memory operation. In any other gear selection, the 12-volt signal is removed and the memory function is disabled. This signal can come from the gear selector switch or the neutral safety switch.

Most systems provide for two seat positions to be stored in memory. Some systems allow for three positions by pushing both position 1 and 2 buttons together. With the seat in the desired position, depressing the SET button and moving the memory select switch to either the memory 1 or 2 position will store the seat position into the module's memory (Figure 14-53).

When the seat is moved from its memory position, the seat memory module transmits the voltage applied from the switch to the motors. The module counts the pulses produced by motor operation and then stores the number of pulses and direction of movement in memory. When the memory switch is closed, the module will operate the seat motors until it counts down to the preset number of pulses. Some systems use a potentiometer or a two-wire Hall sensor to monitor seat position instead of counting pulses.

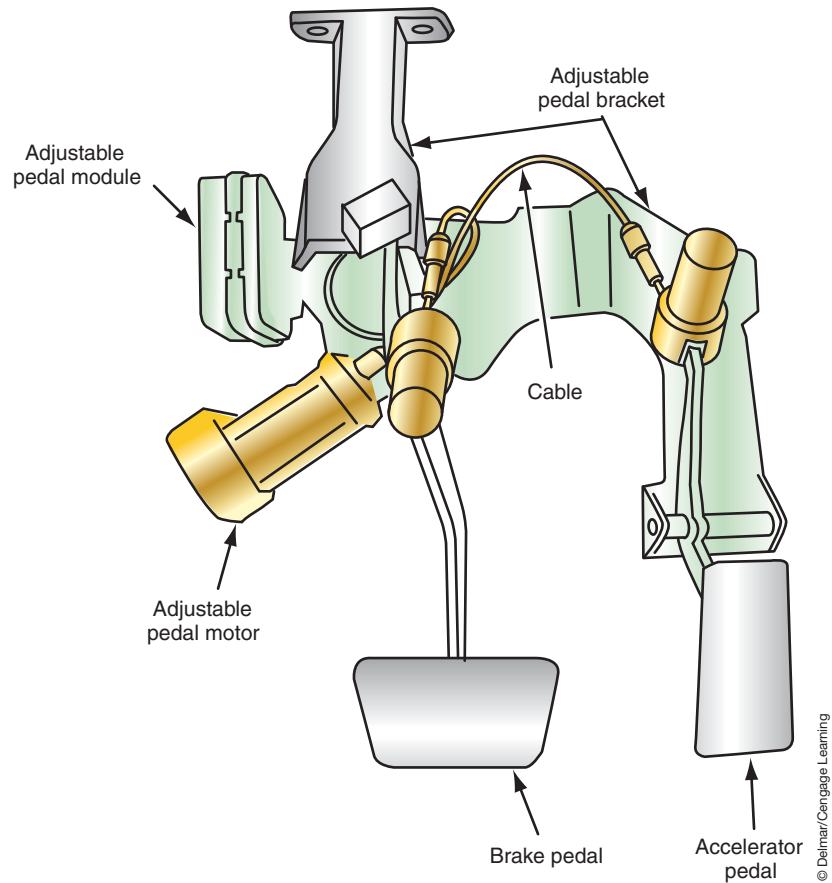
Some systems offer an easy exit feature that is an additional function of the memory seat; the feature provides easier entrance and exit of the vehicle by moving the seat all the way back and down. Some systems also move the steering wheel up and to full retract. Some manufacturers use an easy exit switch as part of the power seat switch assembly. When the easy exit switch is closed, voltage is applied to both memory 1 and 2 inputs of the module. This signal is interrupted by the module to move the seat to its full down and back position. As the seat moves to the easy exit position, it counts the pulses and stores this information in memory. In some systems, the easy exit feature is activated when the key is removed from the ignition switch or when the driver's door is opened.



**FIGURE 14-53** Memory seat circuit.

Memory is not lost when the ignition switch is turned off. However, it is lost if the battery is disconnected. If memory is lost, the position of the seat at the time power is restored becomes set in memory for both positions.

The memory system may include many more features than just moving seats. In addition to the seat positions, some systems allow for two different groups of radio presets,



**FIGURE 14-54** Electrically adjustable pedal assembly.

two separate outside mirror positions, and two different steering wheel tilt positions to be recalled. All of these can be recalled by using the single switch and, on some systems, the remote keyless entry transmitter. Some systems even include electrically adjustable pedals as part of the memory system (Figure 14-54).

**Shop Manual**  
Chapter 14, page 591

## POWER DOOR LOCKS

Electric power locks use either a solenoid or a permanent magnet reversible motor. Due to the high current demands of solenoids, most modern vehicles use PM motors (Figure 14-55). Depending on circuit design, the system may incorporate a relay (Figure 14-56). The relay has two coils and two sets of contacts to control current direction. In this system, the door lock switch energizes one of the door lock relay coils to send battery voltage to the motor. If the door lock switch is placed in the LOCK position, current flow is that shown (Figure 14-57). In the illustration (Figure 14-58), current flows when the door lock switch is placed in the UNLOCK position.

A system that does not use relays is shown (Figure 14-59). The switch provides control of current flow in the same manner as power seats or windows.

Many vehicles are equipped with automatic door locks that are activated when the gear shift lever is placed in the DRIVE position. The doors unlock when the selector is returned to the PARK position.

A **child safety latch** in the door lock system prevents the door from being opened from the inside, regardless of the position of the door lock knob. The child safety latch is activated by a switch designed into the latch bellcrank (Figure 14-60). By placing the latch in the deactivated mode, the door operates as normal.

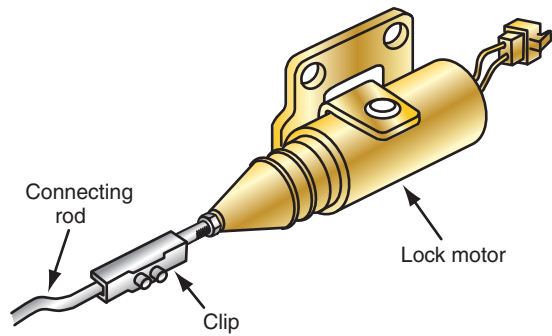


FIGURE 14-55 PM power door lock motor.

© Delmar/Cengage Learning

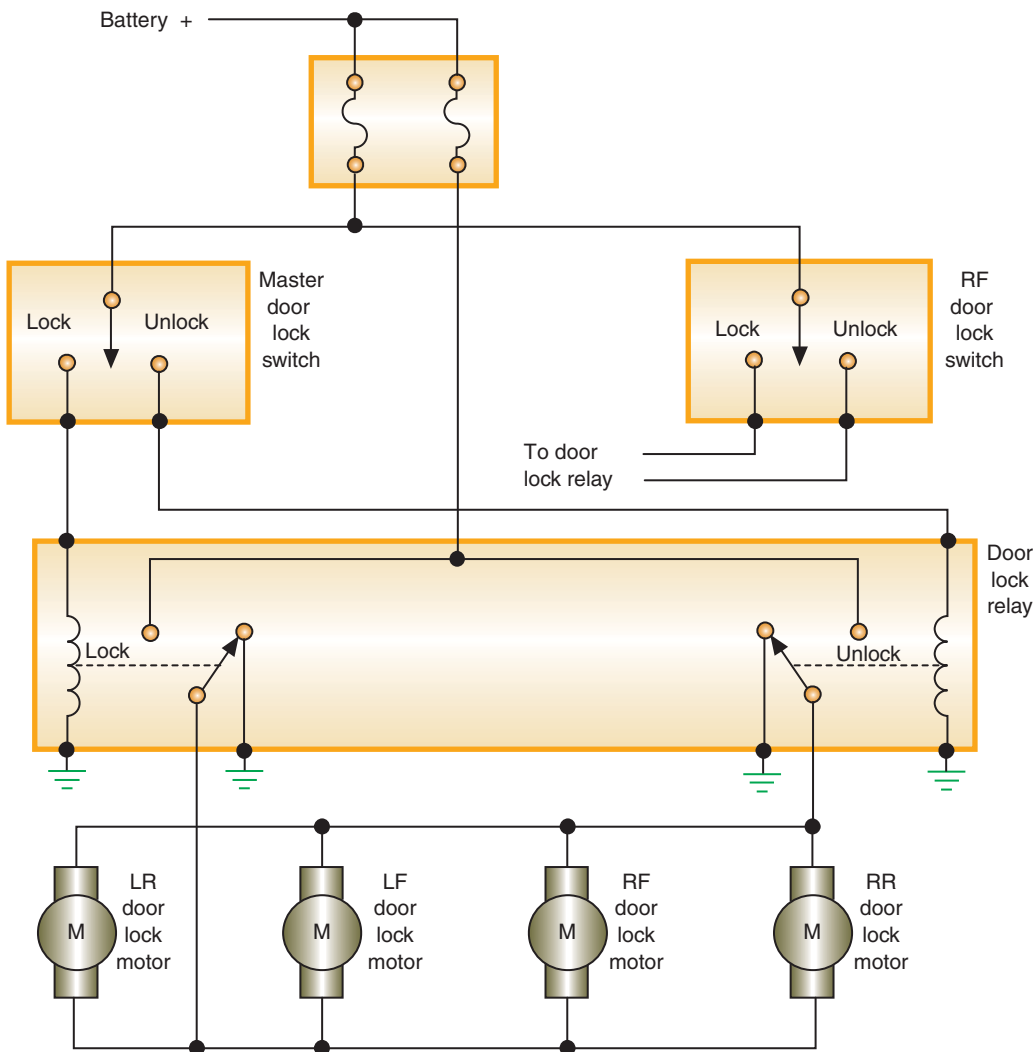
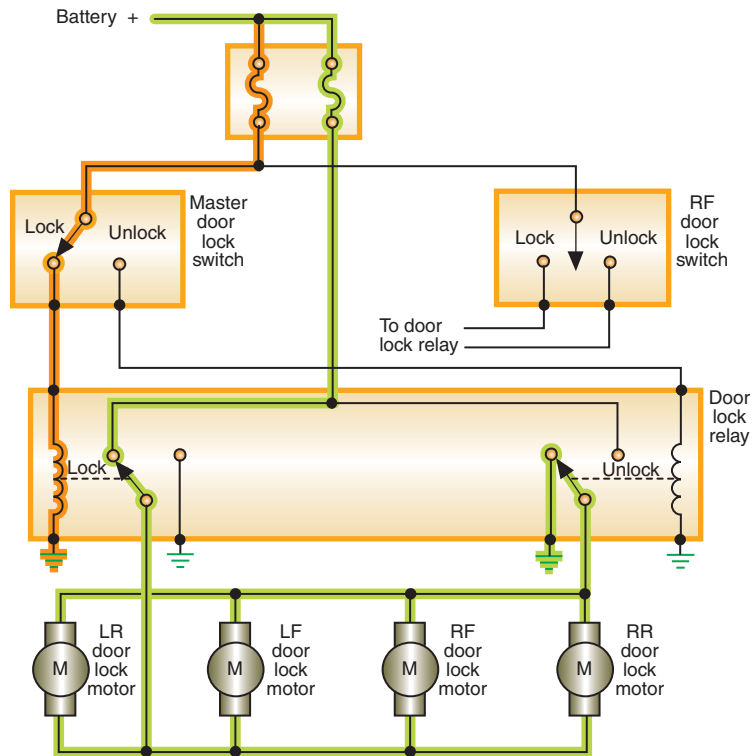


FIGURE 14-56 Power door lock circuit using a relay.

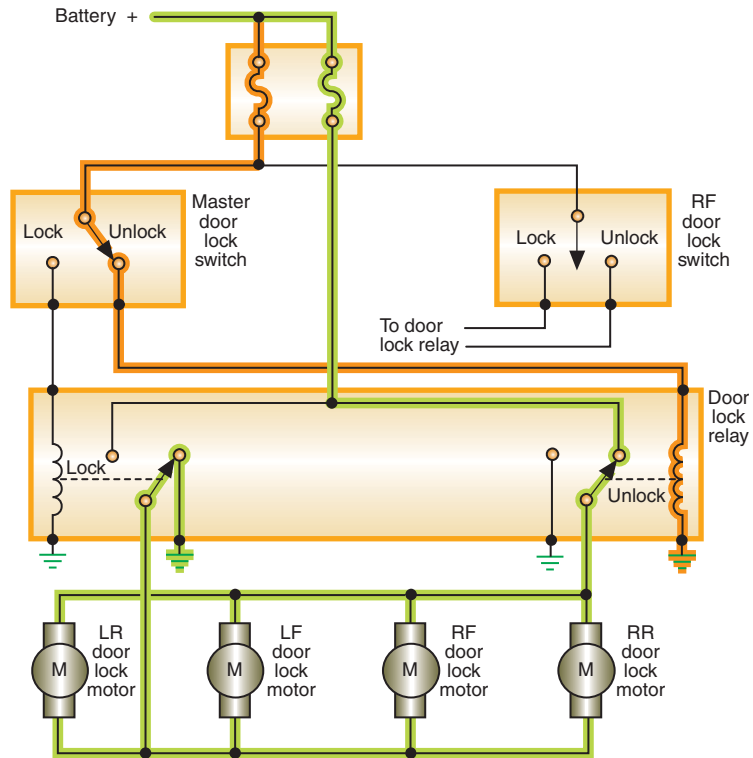
© Delmar/Cengage Learning

**AUTHOR'S NOTE:** Like the power windows, the power locks can be operated by the BCM or door modules. In this case, the switch is nothing more than an input to the door module and the door module controls the relays or the solenoid directly.



**FIGURE 14-57** Current flow in the LOCK position.

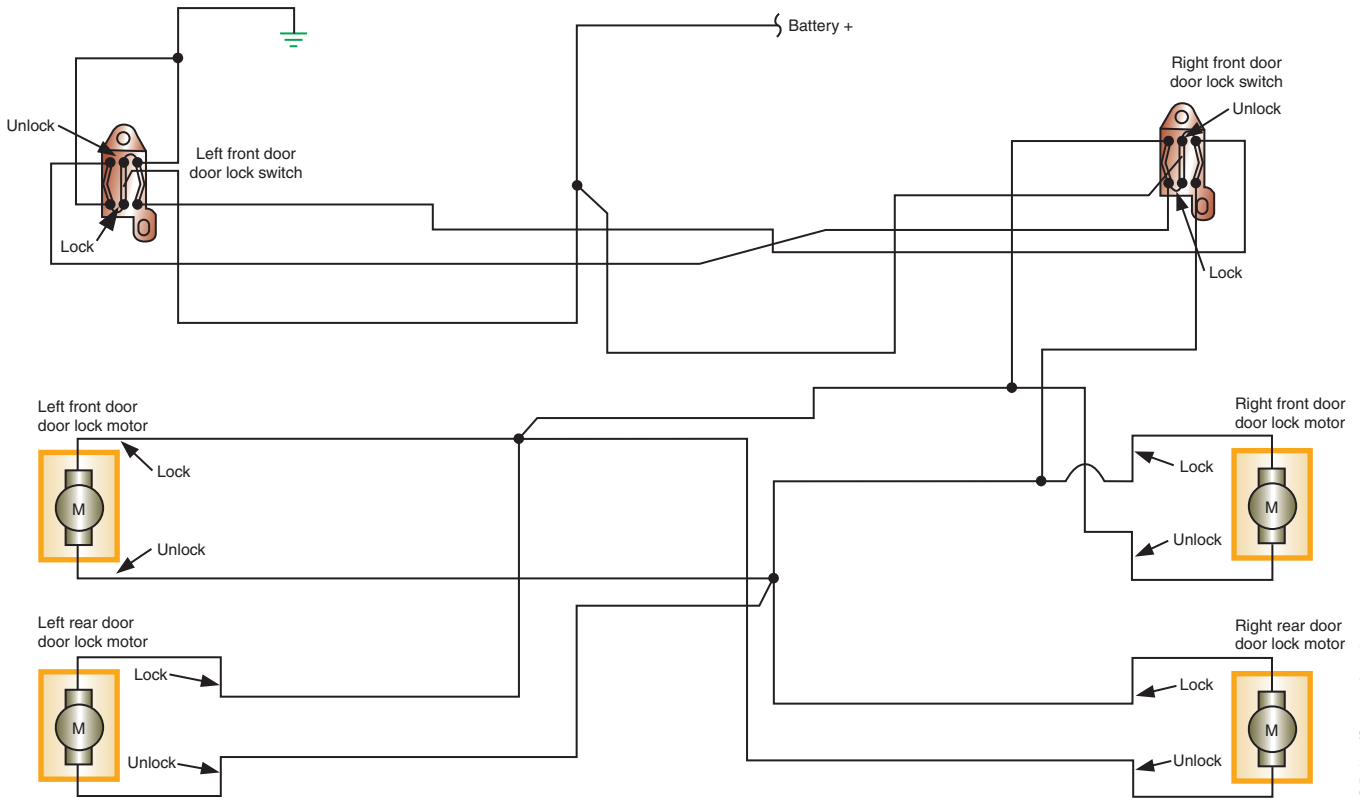
© Delmar/Cengage Learning



**FIGURE 14-58** Current flow in the UNLOCK position.

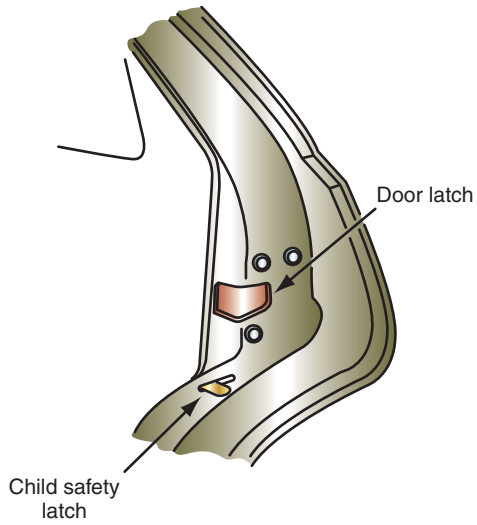
© Delmar/Cengage Learning





© Delmar/Cengage Learning

**FIGURE 14-59** Electronic door lock circuit diagram.



© Delmar/Cengage Learning

**FIGURE 14-60** Child safety latch.

## AUTOMATIC DOOR LOCKS

**Automatic door locks (ADL)** is a passive system used to lock all doors when the required conditions are met. The ADL system is an additional safety and convenience system that uses the existing power door function. Most systems lock the doors when the gear selector is placed in drive, the ignition switch is in RUN, and all doors are shut. Some systems will lock the doors when the gear shift selector is passed through the reverse position; others do not lock the doors unless the vehicle is moving 15 mph or faster.

The system may use the body computer to control the door lock relays (Figure 14-61) or a separate controller (Figure 14-62). The controller (or body computer) takes the place of the door lock switches for automatic operation.

When all of the doorjamb switches are open (doors closed), the ground is removed from the doorjamb input circuit to the controller (Figure 14-63). This signals the controller to enable the lock circuit. When the gear selection is moved from the PARK position, the neutral safety switch removes the power signal from the controller. The controller sends voltage through the LH seat switch to the lock relay coil. Current is sent through the motors to lock all doors.

When the gear selector is returned to the PARK position, voltage is applied through the neutral safety switch to the controller. The controller then sends power to the unlock relay coil to reverse current flow through the motors.

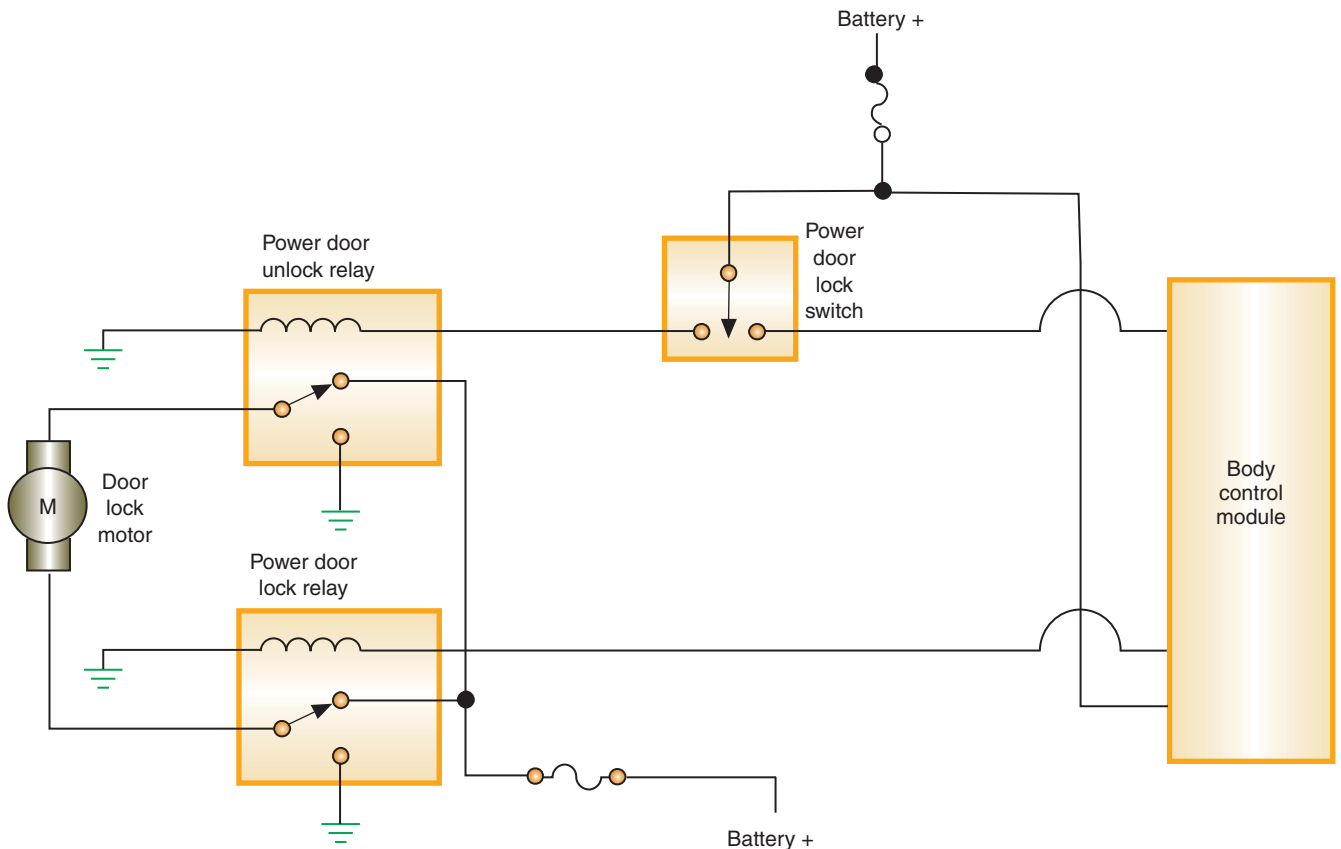
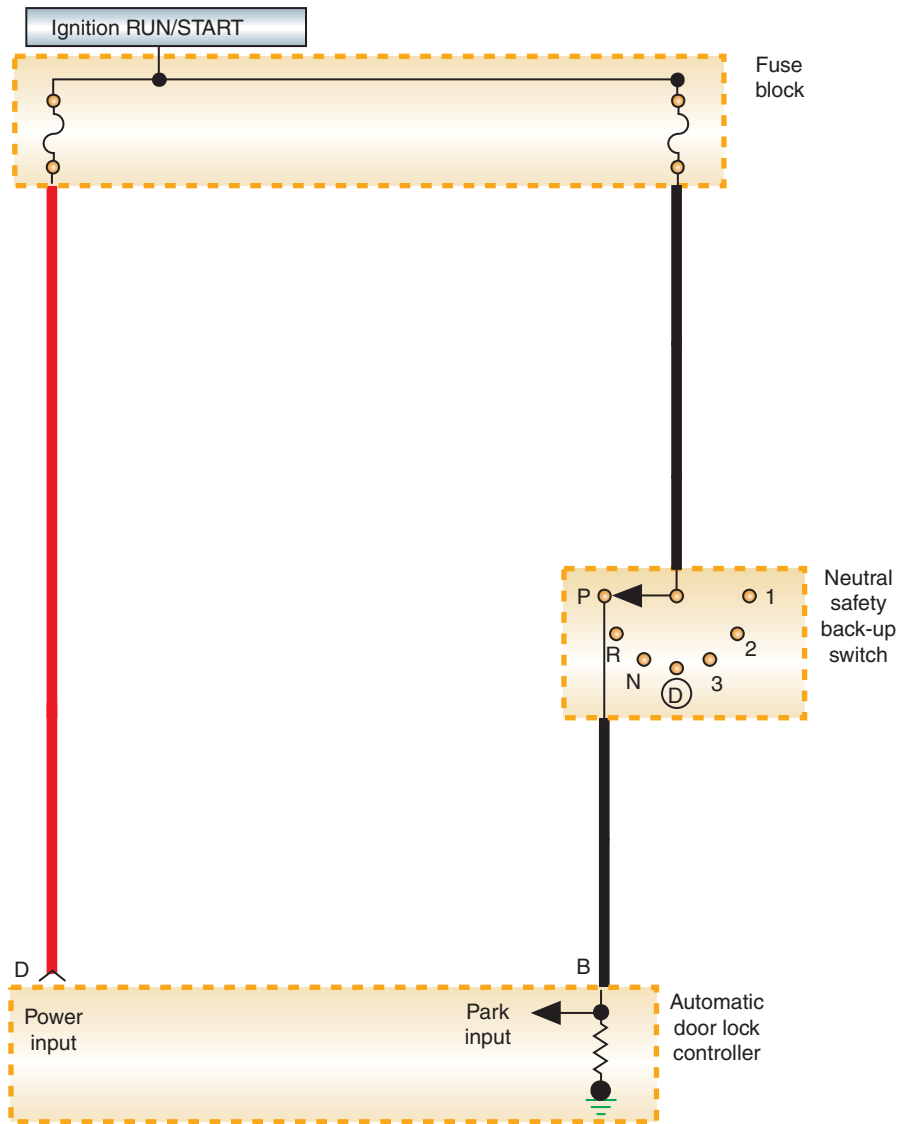


FIGURE 14-61 Automatic door lock system utilizing the body computer.



© Delmar/Cengage Learning

**FIGURE 14-62** Automatic door lock system that utilizes a separate control module.

## KEYLESS ENTRY

The keyless entry system allows the driver to unlock the doors or the deck lid (trunk) from outside the vehicle without the use of a key. The main components of the keyless entry system are the control module, a coded-button keypad located on the driver's door, and the door lock motors.

The keypad consists of five normally open, single-pole, single-throw switches. Each switch represents two numbers: 1-2, 3-4, 5-6, 7-8, and 9-0 (Figure 14-64).

The keypad is wired into the circuit to provide input to the control module. The control module is programmed to lock the doors when the 7-8 and 9-0 switches are closed at the same time. The driver's door can be unlocked by entering a five-digit code through the keypad. The unlock code is programmed into the controller at the factory. However, the driver may enter a second code. Either code will operate the system.

**Shop Manual**  
Chapter 14, page 593

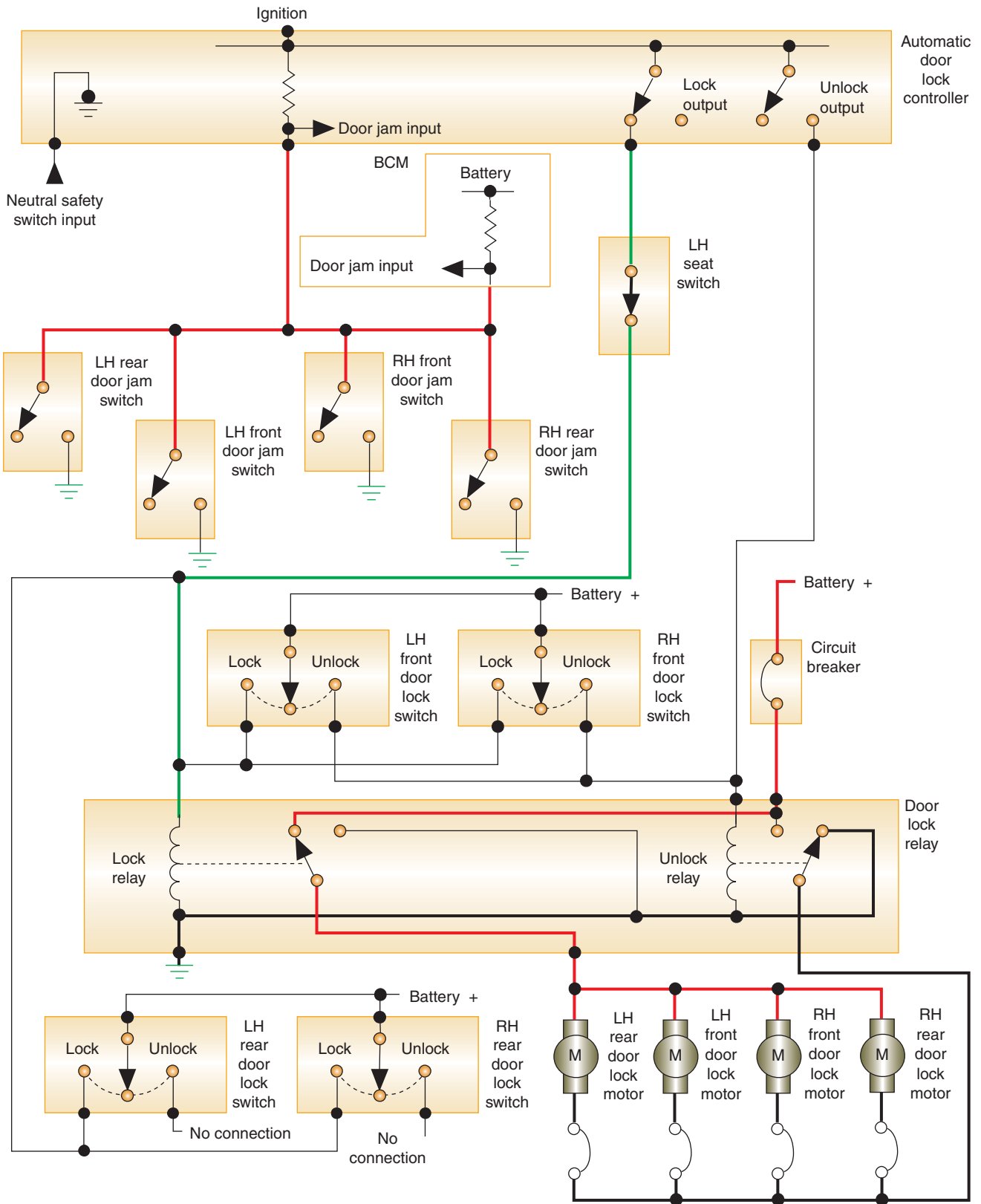


FIGURE 14-63 Automatic door lock system circuit schematic indicating operation during the lock procedure.



© Delmar/Cengage Learning

**FIGURE 14-64** Keyless entry system keypad.

In addition to the aforementioned functions, the keyless entry system also:

1. Unlocks all doors when the 3-4 button is pressed within 5 seconds after the five-digit code has been entered.
2. Releases the deck lid lock if the 5-6 button is pressed within 5 seconds of code entry.
3. Activates the illuminated entry system if one of the buttons is pressed.
4. Operates in conjunction with the automatic door lock system and may share the same control module.

See the schematic (Figure 14-65) of the keyless entry system used by Ford. When the 7-8 and 9-0 buttons on the keypad are pressed, the controller applies battery voltage to all motors through the lock switch.

When the five-digit code is entered, the controller closes the driver's switch to apply voltage in the opposite direction to the driver's door motor. If the driver presses the 3-4 button, the controller will apply reverse voltage to all motors to unlock the rest of the doors.

## Remote Keyless Entry

Many vehicles are equipped with a remote keyless entry system that is used to lock and unlock the doors, turn on the interior lights, and release the trunk latch. A small receiver is installed in the vehicle. The transmitter assembly is a hand-held item attached to the key ring (Figure 14-66). Pressing a button on a hand-held transmitter will allow operation of the system from a distance of 25 to 50 feet (7.6 to 15.2 m). When the UNLOCK button is pressed, the driver's door unlocks and the interior lights are illuminated. If a theft deterrent system is installed on the vehicle, it is also disarmed when the unlock button is pressed. A driver exiting the vehicle can activate the door locks and arm the security system by pressing the lock button. Many transmitters also have a third button for opening the deck lid.

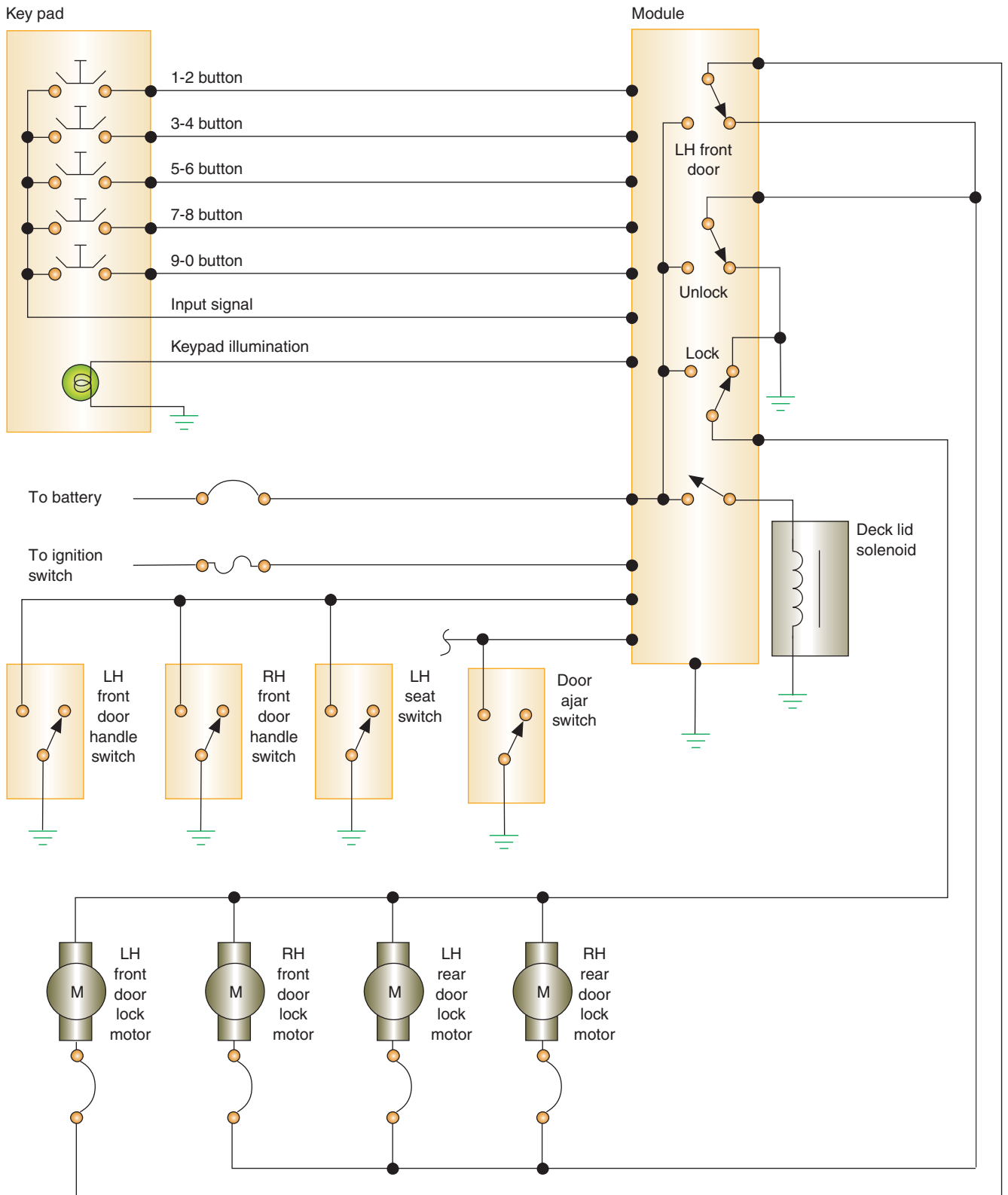
The system operates at a fixed radio frequency. If the unit does not work from a normal distance, check for two conditions: weak batteries in the remote transmitter or a stronger radio transmitter close by (radio station, airport transmitter, etc.).

## Keyless Start

An enhancement to the remote keyless entry system is the **keyless start system**. This system allows the vehicle to be started without the use of an ignition key. Early versions of these systems use the key fob to unlock the vehicle doors and disarm the antitheft system. At the same time, a message is sent that the engine can be started. Instead of the ignition key, the pointed end of the fob is inserted into the ignition switch. This activates an infrared data exchange that unlocks the steering column and starts the engine.

Newer versions have improved on this. They no longer require the use of a key fob to unlock the doors or to start the engine. The following is the Keyless Go system used on Mercedes-Benz vehicles.

**Shop Manual**  
Chapter 14, page 593



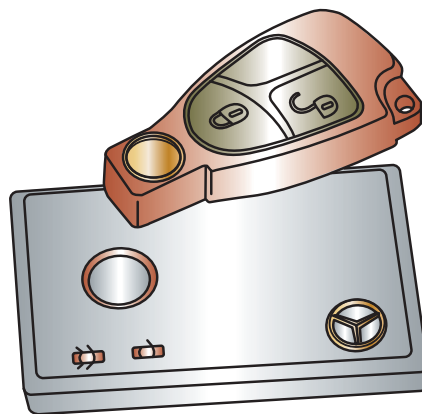
**FIGURE 14-65** Simplified keyless entry system schematic.

This system will use a transmitter card (Figure 14-67), signal acquisition and actuation modules (SAMs) that are installed throughout the vehicle, an electronic ignition switch (EIS), and a total of seven antennas. There are two antennas on the left side, two on the right side, and three in the trunk area.



© Delmar/Cengage Learning

**FIGURE 14-66** Remote keyless entry system transmitter.



© Delmar/Cengage Learning

**FIGURE 14-67** Transponder card used for entry and vehicle starting.

The Keyless Go module will communicate with the transmitter card at a frequency of 125 kHz. In order to receive messages, the transponder card must be within 5 feet (1.5 m) of the vehicle. The electromagnetic field of the antennas causes the transmitter card to send its code by RF signal at a frequency of 433 MHz to the rear SAM. The antennas will determine if the transmitter card is located within the vehicle or outside of the vehicle.

When the driver approaches the vehicle with the transponder in his possession and attempts to open the door with the door handle, a capacitive sensor or microswitch will signal the Keyless Go module to activate the left-front door antenna. Messages are exchanged between the module and the card to determine authorized entry. If the entry is authorized, the doors are unlocked and the door will open.

When the vehicle doors are to be locked, the antennas will determine if the card's signal is coming from inside or outside of the vehicle. This is determined by a decrease in antenna fields in the interior due to the sheet metal of the body. The radio range is limited to a defined range. Also, the ranges overlap between antennas that further refine the location of the card. If it is determined that the card is in the vehicle or trunk, the doors cannot be locked. A warning message will be displayed in the instrument cluster notifying the driver that the card is still in the vehicle.

The engine starting function can be performed only if the antenna determines the card is within the vehicle. Also, the transmission must be in park and the driver's foot on the brake pedal. Once these conditions are met, the driver simply presses the START/STOP button on the gear shift handle or mounted in the dash to start the engine (Figure 14-68). To shut off the engine, the driver simply exits the vehicle with the card in possession. The module looks for the card every 10 seconds; if the card is no longer in the vehicle, the engine shuts off.

Some manufactures use the remote keyless entry transponder to do the function of the card being described here.

Not all manufacturers use the auto shut off feature.





© Delmar/Cengage Learning

FIGURE 14-68 Start/Stop button.

### Shop Manual

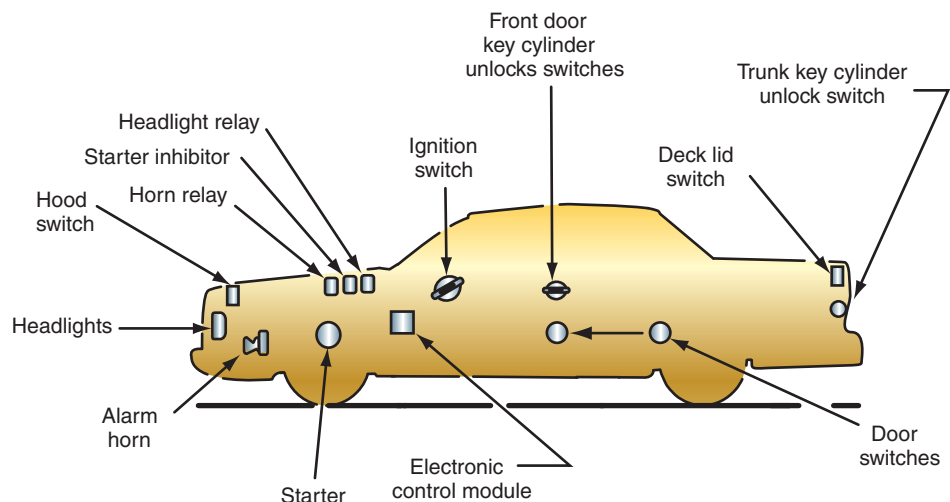
Chapter 14, page 594

## ANTITHEFT SYSTEMS

A vehicle is stolen in the United States every 26 seconds. In response to this problem, vehicle manufacturers are offering antitheft systems as optional or standard equipment. These systems are deterrents designed to scare off would-be thieves by sounding alarms and/or disabling the ignition system. The illustration (Figure 14-69) shows many of the common components that are used in an antitheft system. These components include:

1. An electronic control module.
2. Door switches at all doors.
3. Trunk key cylinder switch.
4. Hood switch.
5. Starter inhibitor relay.
6. Horn relay.
7. Alarm.

In addition, many systems incorporate the exterior lights into the system. The lights are flashed if the system is activated.



© Delmar/Cengage Learning

FIGURE 14-69 Typical components of an antitheft system.

For the system to operate, it must first be **armed**. This is done when the ignition switch is turned off and the doors are locked. When the driver's door is shut, a security light will illuminate for approximately 30 seconds to indicate that the system is armed and ready to function. If any other door is open, the system will not arm until it is closed. Once armed the system is ready to detect an illegal entry.

The control module monitors the switches. If the doors or trunk are opened or the key cylinders are rotated, the module will activate the system. The control module will sound the alarm and flash the lights until the timer circuit has counted down. At the end of the timer function, the system will automatically rearm itself.

Some systems use ultrasonic sensors that will signal the control module if someone attempts to enter the vehicle through the door or window. The sensors can be placed to sense the parameter of the vehicle and sound the alarm if someone enters within the protected parameter distance.

The system can also use current sensitive sensors that will activate the alarm if there is a change in the vehicle's electrical system. The change can occur if the courtesy lights come on or if an attempt is made to start the engine.

The following systems are provided to give you a sample of the types of antitheft systems used. Figure 14-70 illustrates an antitheft system that uses a separate control module and an inverter relay. If the system is triggered, it will sound the horn, flash the low-beam headlights, the taillights, and parking lamps, and disable the ignition system.

The arming process is started when the ignition switch is turned off. Voltage provided to the module at terminal K is removed. When the door is opened, a voltage is applied to the courtesy lamp circuit through the closed switch to terminal 2 of the inverter relay. This voltage energizes the inverter relay and provides a ground for module terminal J. This signal is used by the control module to provide an alternating ground at terminal D, causing the indicator lamp to blink. The flashing indicator light alerts the driver that the system is not armed. When the door lock switch is placed in the LOCK position, battery voltage is applied to terminal G of the module. The module uses this signal to apply a steady ground at terminal D, causing the indicator light to stay on continuously. When the door is closed, the door switch is opened. The opened door switch de-energizes the inverter relay coil. Terminal J is no longer grounded, and the indicator light goes out after a couple of seconds.

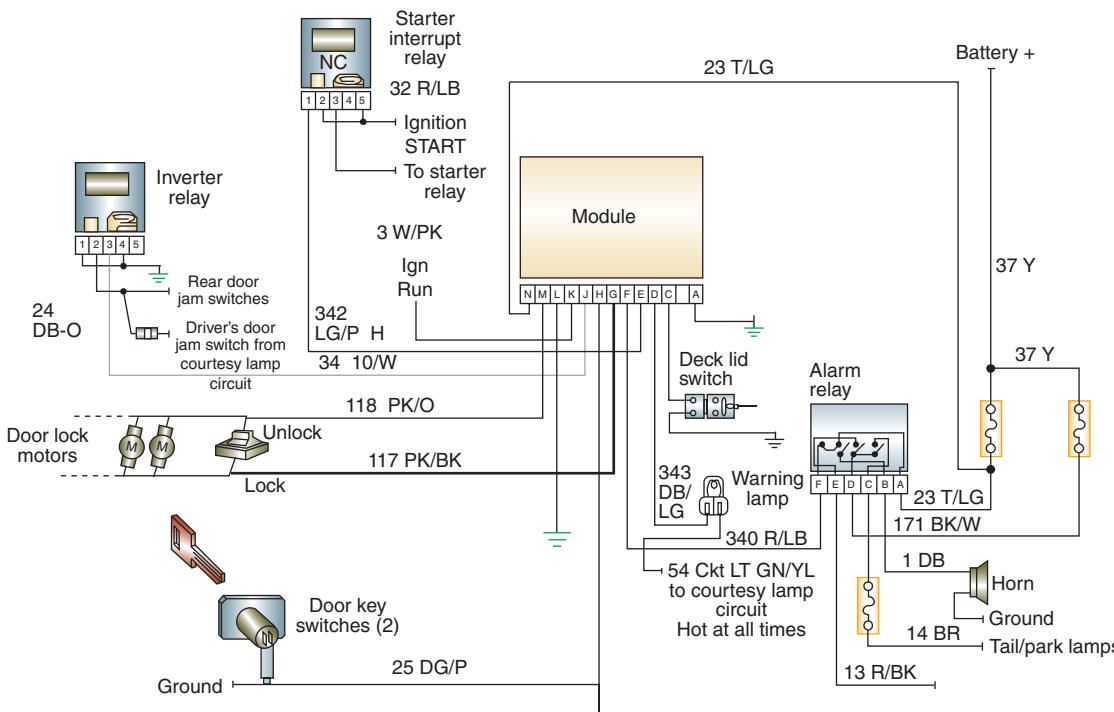


FIGURE 14-70 Circuit schematic of Ford's antitheft system.

© Delmar/Cengage Learning

To disarm the system, one of the front doors must be opened with a key or by pressing the correct code into the keyless entry keypad. Unlocking the door closes the lock cylinder switch and grounds terminal H of the module. This signal disarms the system.

Once the system is armed, if terminal J and C receive a ground signal, the control module will trigger the alarm. Terminal C is grounded if the trunk tamper switch contacts close. Terminal J is grounded when the inverter relay contacts are closed. The inverter relay is controlled by the doorjamb switches. If one of the doors is opened, the switch closes and energizes the relay coil. The contacts close and ground is provided to terminal J.

When the alarm is activated, a pulsating ground is provided at module terminal F. This pulsating ground energizes and de-energizes the alarm relay. As the relay contacts open and close, a pulsating voltage is sent to the horns and exterior lights.

At the same time, the start interrupt circuit is activated. The start interrupt relay receives battery voltage from the ignition switch when it is in the START position. When the alarm is activated, the module provides a ground through terminal E, causing the relay coil to be energized. The energized relay opens the circuit to the starter system, preventing starter operation.

Often the BCM will control the functions of the antitheft system. In this case the inputs and outputs are wired to the BCM (Figure 14-71). The BCM will monitor the arming process

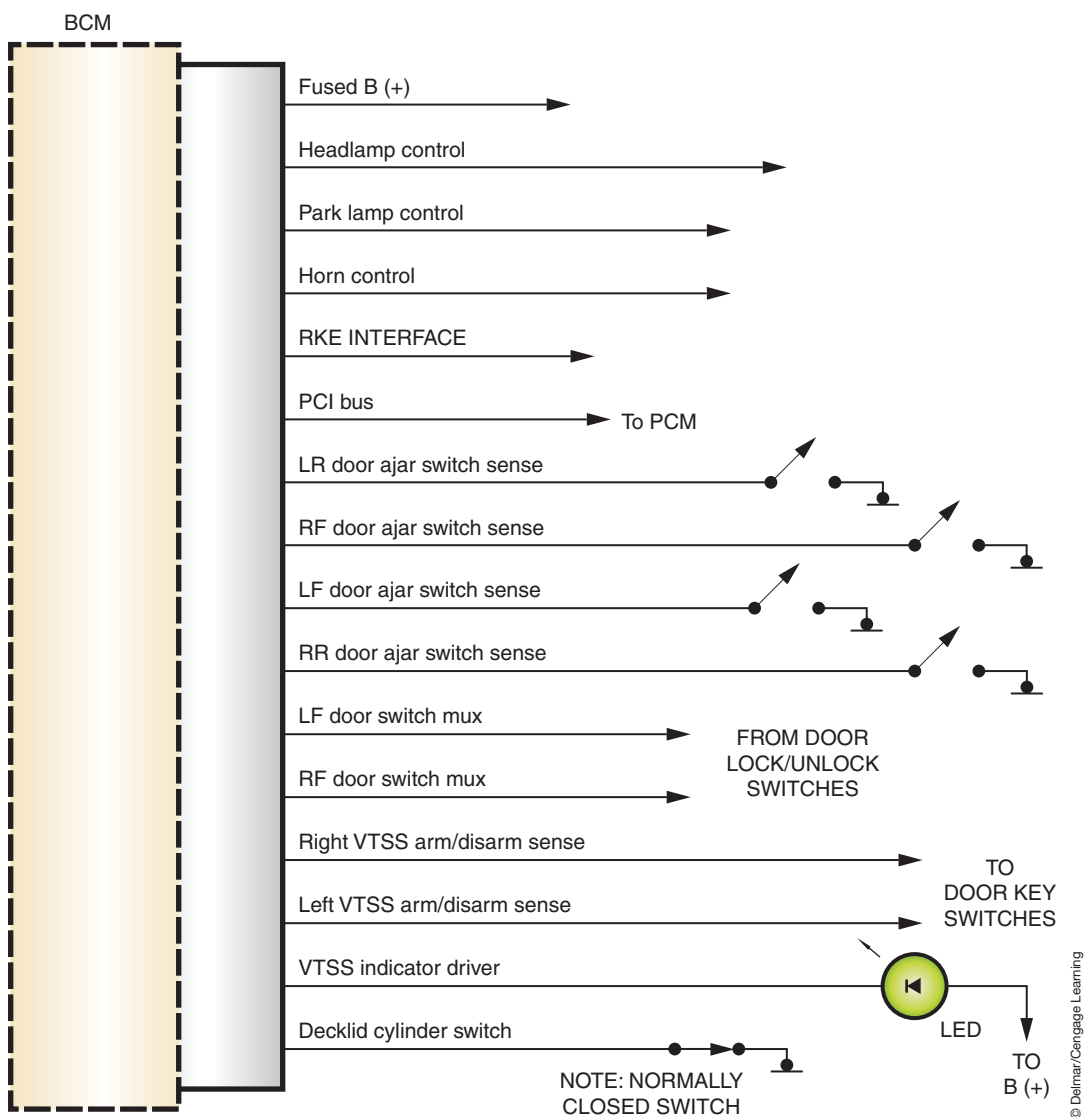


FIGURE 14-71 BCM-controlled antitheft system.

and will then trigger the alarm if an unauthorized entry is attempted. At this time the BCM will control the exterior lamps to cause them to flash; it also will cycle the horn on and off. The BCM will also send a data bus message to the PCM not to start the engine. The PCM is programmed that it must receive a data bus message that it is alright to start. If the data bus circuit should fail, the engine may not start, since this message cannot be received.

Systems that incorporate an intrusion monitor will detect movement of a person or object inside the passenger compartment. The intrusion monitor uses a single sensor that transmits 40-kHz ultrasonic sound waves. The sensor will also receive the ultrasonic sound waves. If an object moves within the coverage area of the sensor, the received ultrasonic signals are distorted. This distortion is detected and processed by the module, which then signals the antitheft system to trigger.

## IMMOBILIZER SYSTEMS

The **immobilizer system** is designed to provide protection against unauthorized vehicle use by disabling the engine if an invalid key is used to start the vehicle or an attempt to hot-wire the ignition system is made. Manufacturers have several different names for this system. The following are examples of system operation.

The primary components of the system include the immobilizer module, ignition key with transponder chip, the PCM, and an indicator lamp. The immobilizer module is either mounted to the steering column or in the instrument panel. It may include an integral antenna that surrounds the ignition switch lock cylinder (Figure 14-72). If the module is remote mounted in the instrument panel, then it is connected to an antenna by a cable.

The system includes special keys that have a transponder chip under the covering (Figure 14-73). Most systems are capable of recognizing up to eight different keys. Any additional keys that are to be used with the vehicle require programming to the immobilizer module. Most systems provide a procedure that allows the customer to program additional keys if they have two valid immobilizer keys that are programmed to the vehicle already.

**Shop Manual**  
Chapter 14, page 596



FIGURE 14-72 The immobilizer module with halo antenna.



FIGURE 14-73 The immobilizer key has an internal transponder chip. The key cover was cut off for this illustration.

© Delmar/Cengage Learning

© Delmar/Cengage Learning

## System Operation

The immobilizer module contains a radio frequency transceiver and a microprocessor. When the ignition switch is placed in the RUN position, the immobilizer module begins to transmit a radio frequency signal to the transponder in the key. The transponder in the key then sends its coded message to the immobilizer module. If the message properly identifies the key as being valid, the immobilizer module sends a message over the data bus to the PCM indicating that the engine may be started. If the response received from the key transponder is missing or identifies the key as invalid, the immobilizer module sends an “invalid key” message to the PCM over the data bus.

**AUTHOR’S NOTE:** The default condition in the PCM is “invalid key.” If the PCM does not receive any messages from the immobilizer module, the engine is prevented from starting.

**AUTHOR’S NOTE:** When the system is preventing the engine from running, it will allow the engine to start and run for about 2 seconds and then will shut the engine off. Some systems will prevent the starter from engaging after a set number of attempts with an invalid key are made. In this case, the vehicle will not recover until a valid key is used.

The immobilizer module is programmed with a unique secret key code and also retains in memory the unique ID number of all keys that are programmed to the system. The secret key code is transmitted to the keys during the programming function and is stored in the transponder. In addition, the secret key code is programmed into the PCM. Another identification code called a PIN is used to gain secured access to the immobilizer module for service. The immobilizer module also is programmed with the vehicle identification number (VIN). All messages transmitted by the immobilizer module are scrambled to reduce the possibility of unauthorized immobilizer module access or disabling.

The immobilizer module also sends indicator lamp status messages. The indicator lamp will normally illuminate for 3 seconds for a bulb check when the ignition switch is first placed in the RUN position. After the bulb check is complete, the lamp should go out. If the lamp remains on after the bulb check, this indicates that the immobilizer module has detected a system malfunction or that the system has become inoperative. If the lamp flashes after the bulb check is completed, this indicates that an invalid key is detected or that a key-related fault is present.

Each key has a unique transponder identification code that is permanently programmed into it. When a key is programmed into the immobilizer module, the transponder identification code is then stored in the immobilizer’s memory. In addition, the key learns the secret key code from the immobilizer module and permanently programs it into its transponder memory. For the engine to start and run, all of the following must be in place:

- Each key’s transponder ID must be programmed into the immobilizer module.
- The immobilizer’s secret key code must be programmed into each key.
- The VIN number programmed in the immobilizer module must match the VIN in the PCM.
- The data bus network must be intact to allow messages to be sent and received between the immobilizer module and the PCM.
- The immobilizer module and the PCM must have properly functioning power and ground circuits.



**AUTHOR'S NOTE:** In 1996, GM introduced an immobilizer system that does not use a chip in the key. This system has a Hall-effect sensor in the key cylinder that measures the magnetic properties of the key as it is inserted into the cylinder. The cut pattern of every key has its own magnetic identity. If the wrong key is inserted into the lock cylinder, the car will not start, even if the lock cylinder turns.



## A BIT OF HISTORY

Ralph R. Teetor was born August 17, 1890. At the age of 10, Ralph built a dynamometer. At the age of 12, he designed and built his own gasoline-powered automobile. Also at age 12, he built a generator to supply electricity not only to his home but for every house on the block. His most famous automotive invention was the Speedostat, which is now known as cruise control. He also designed and patented one of the first automatic gear shifts. However, the story of Ralph R. Teetor becomes more amazing once it is learned that he was totally blind from the age of 5. In 1902, a newspaper reporter wrote a story on Ralph but never noticed his blindness.

## ELECTRONIC CRUISE CONTROL SYSTEMS

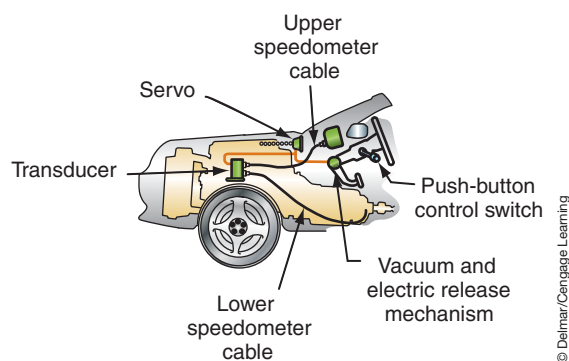
**Cruise control** is a system that allows the vehicle to maintain a preset speed with the driver's foot off the accelerator. Cruise control was first introduced in the 1960s for the purpose of reducing driver fatigue. When engaged, the cruise control system sets the throttle position to maintain the desired vehicle speed.

Most cruise control systems are a combination of electrical and mechanical components. The components used depend on manufacturer and system design. However, the operating principles are similar.

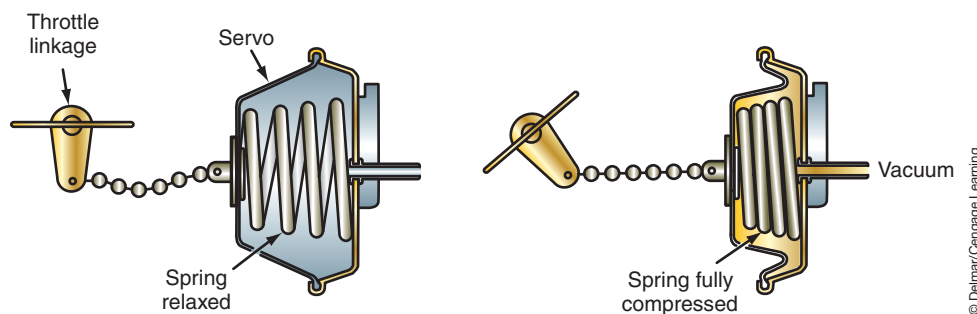
Early cruise control systems were generally electromechanical systems (Figure 14-74). These systems used a transducer that received vehicle speed signals through the speedometer cable. Electrical signals from the control switch, brake switch, or clutch switch were sent to the transducer. In addition, the transducer received the engine manifold vacuum. It regulated the vacuum to the servo through the electrical signals received.

The servo controls the throttle plate position. It is connected to the throttle plate by a rod, bead chain, or Bowden cable. The servo maintains the set speed by receiving a controlled amount of vacuum from the transducer. When a vacuum is applied to the servo, the spring is compressed and the throttle plate is moved to increase speed (Figure 14-75). When the vacuum is released, the spring returns the throttle plate to reduce engine speed.

Electronic cruise control has built upon the basic electromechanical system to provide more accurate speed control and safer operation.

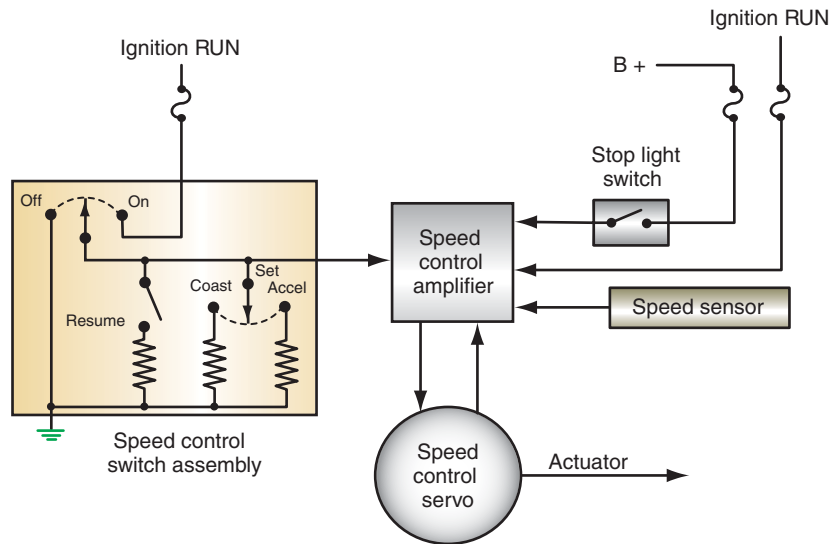


**FIGURE 14-74** Components of typical electromechanical cruise control system.



**FIGURE 14-75** Cutaway view of the servo. Vacuum is used to compress the spring and open the throttle.

Electromechanical cruise control receives its name from two subsystems: the electrical and mechanical portion.



**FIGURE 14-76** Block diagram of electronic cruise control system.

© Delmar/Cengage Learning

Some manufacturers combine the transducer and servo into one unit. They usually refer to this unit as a servomotor.

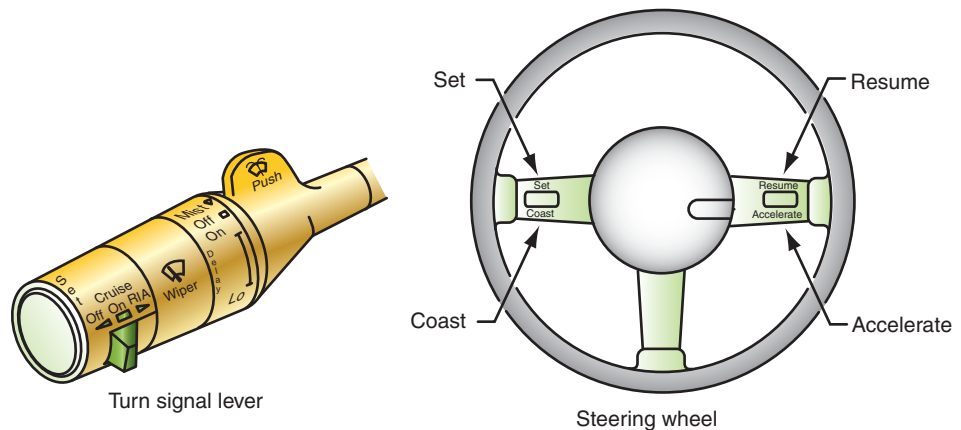
The electronic cruise control system uses an electronic module to operate the actuators that control throttle position (Figure 14-76). Other benefits include:

- More frequent throttle adjustments per second.
- More consistent speed increase/decrease when using the tap-up/tap-down feature.
- Greater correction of speed variation under loads.
- Rapid deceleration cutoff when deceleration rate exceeds programmed rates.
- Wheelspin cutoff when acceleration rate exceeds programmed parameters.
- System malfunction cutoff when the module determines there is a fault in the system.

## Common Components

Common components of the electronic cruise control system include:

1. The control module: The module can be a separate cruise control module, the PCM, or the BCM. The operation of the systems are similar regardless of the module used.
2. The control switch (Figure 14-77): Depending on system design, the control switch contacts apply the ground circuit through resistors. Because each resistor has a different value, a different voltage is applied to the control module. In some systems, the control switch will send a 12-volt signal to different terminals of the control module.



**FIGURE 14-77** The control switch can be mounted on the turn signal stock or into the steering wheel. The switch is used to provide driver inputs for the system.

© Delmar/Cengage Learning



3. The brake or clutch switch.
4. Vacuum release switch.
5. Servo: The servo operates on a vacuum that is controlled by supply and vent valves. These operate from controller signals to solenoids.

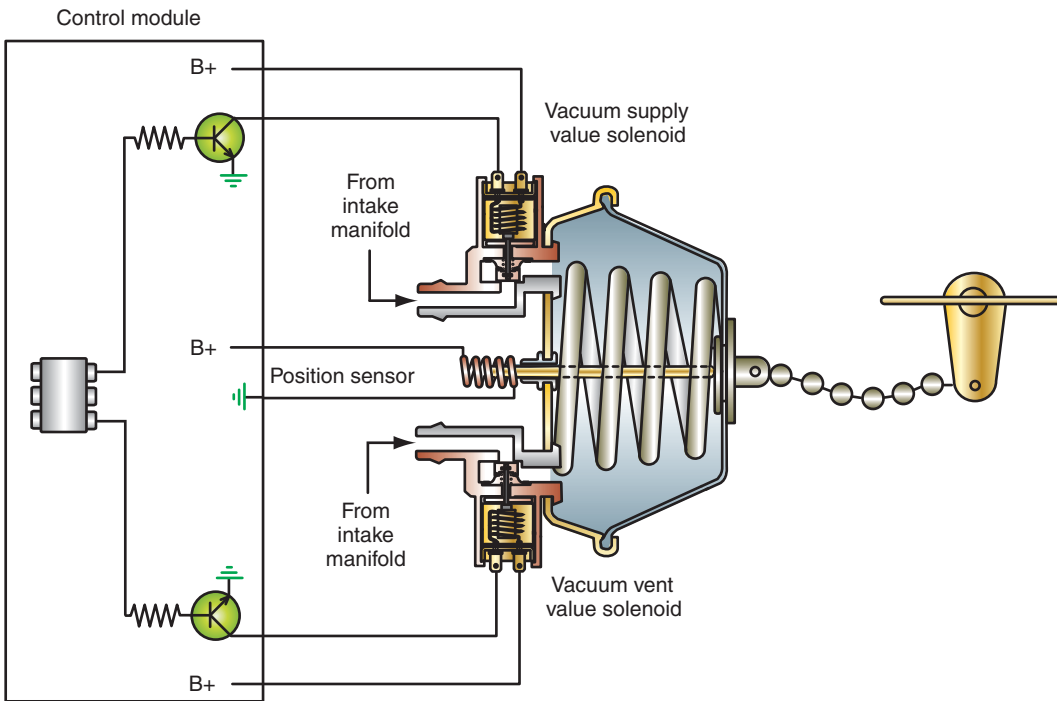
Depending on system design, the sensors used as inputs to the control module include the vehicle speed sensor, servo position sensor, and throttle position sensor. Other inputs are provided by the brake switch, instrument panel switch, control switch, and the park-neutral switch.

The control module receives signals from the speed sensor and the control switch. When the vehicle speed is fast enough to allow cruise control operation and the driver pushes the SET button on the control switch, an electrical signal is sent to the controller. The voltage level received by the controller is set in memory. This signal is used to create two additional signals. The two signal values are set at 1/4 mph above and below the set speed. The module uses the comparator values to change vacuum levels at the servo to maintain set vehicle speed.

**Three safety modes are operated by the control module:**

1. Rapid deceleration cutoff: If the module determines that deceleration rate is greater than programmed values, it will disengage the cruise control system and return operation back over to the driver.
2. Wheelspin cutoff: If the control module determines that the acceleration rate is greater than programmed values, it will disengage the system.
3. System malfunction cutoff: The module checks the operation of the switches and circuits. If it determines there is a fault, it will disable the system.

The vacuum-modulated servo is the primary actuator. Vacuum to the servo is controlled by two solenoid valves: supply and vent. The vent valve is a normally open valve and the supply valve is normally closed (Figure 14-78). The servo receives signals from the controller to operate the solenoid valves to maintain a preset throttle position.



© Delmar/Cengage Learning

**FIGURE 14-78** Servo valve operation in electronic control system. The servo position sensor informs the controller of servo operation and position.



**FIGURE 14-79** An electronic throttle control throttle body.

### Shop Manual

Chapter 14, page 605

## Principles of Operation

When the driver sends a SET signal to the controller, it sets the voltage signals received from the vehicle speed sensor (VSS) into memory. It then determines the high and low comparators.

The controller energizes the supply and vent valves to allow manifold vacuum or atmospheric pressure to enter the servo. The servo uses the vacuum and pressure to move the throttle and maintain the set speed. The vehicle speed is maintained by balancing the vacuum in the servo. The vacuum used to move the servo may be an engine vacuum or may be supplied by a vacuum pump.

If the voltage signal from the VSS drops below the low comparator value, the control module energizes the supply valve solenoid to allow more vacuum into the servo and increases the throttle opening. When the VSS signal returns to a value within the comparator levels, the supply valve solenoid is de-energized.

If the VSS signal is greater than the high comparator value, the control module de-energizes the vent solenoid valve to release vacuum in the servo. The vehicle speed is reduced until the VSS signals are between the comparator values, at which time the control module will energize the vent valve solenoid again. This constant modulation of the supply and vent valves maintains vehicle speed.

During steady cruise conditions, both valves are closed and a constant vacuum is maintained in the servo.

Many manufacturers now use electronic throttle control (ETC) systems instead of cables to operate the throttle body. The ETC throttle body (Figure 14-79) uses a motor to actuate the throttle plate. The driver's movement of the accelerator pedal is an input to the PCM. The PCM then directly controls the placement of the ETC throttle body plates. When ETC is used, cruise control servos are not necessary. Inputs and operation are the same as just described, except the output is to the ETC throttle body motor instead of the servo solenoids.

## ELECTRONIC SUNROOF CONCEPTS

Many manufacturers have introduced electronic control of their electric sunroofs. These systems incorporate a pair of relay circuits and a timer function into the control module. Although there are variations between manufacturers, the systems discussed here provide a study of the two basic types of systems.

### Shop Manual

Chapter 14, page 611

## Electronically Controlled Toyota Sunroof

Refer to schematic (Figure 14-80) of a sunroof control circuit used by Toyota. The movement of the sunroof is controlled by the motor that operates a drive gear. The drive gear either pushes or pulls the connecting cable to move the sunroof.

Motor rotation is controlled by relays that are activated according to signals received from the slide, tilt, and limit switches. The limit switches are operated by a cam on the motor (Figure 14-81).

**AUTHOR'S NOTE:** The schematics used to explain the operation of the Toyota sunroof use logic gates. If needed, refer to Chapter 12 of this manual to review the operation of the gates.

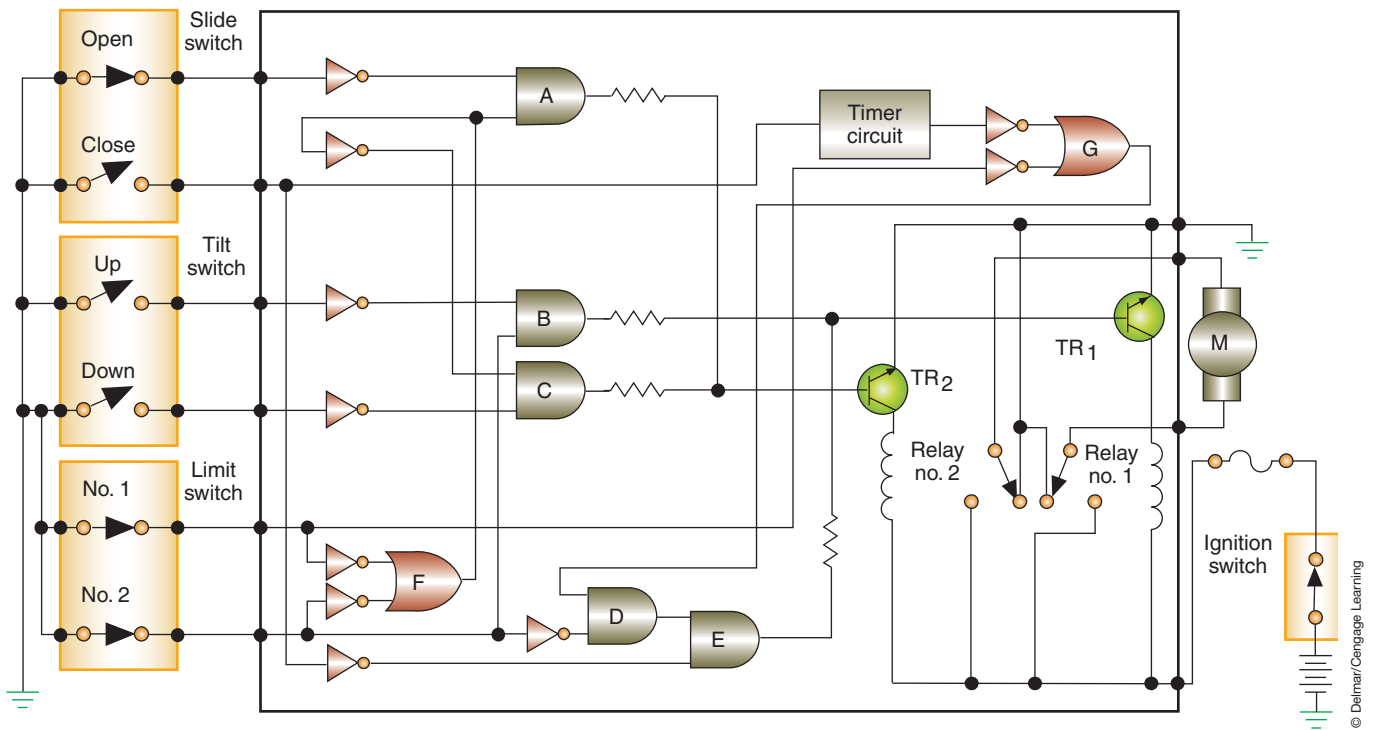


FIGURE 14-80 Toyota sunroof circuit using electronic controls.

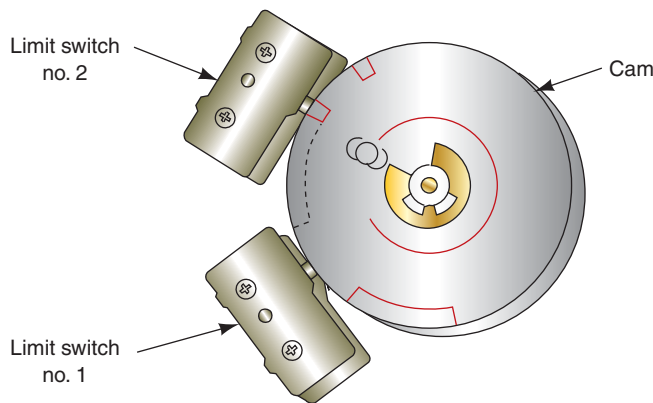


FIGURE 14-81 The limit switches operate off a cam on the motor.

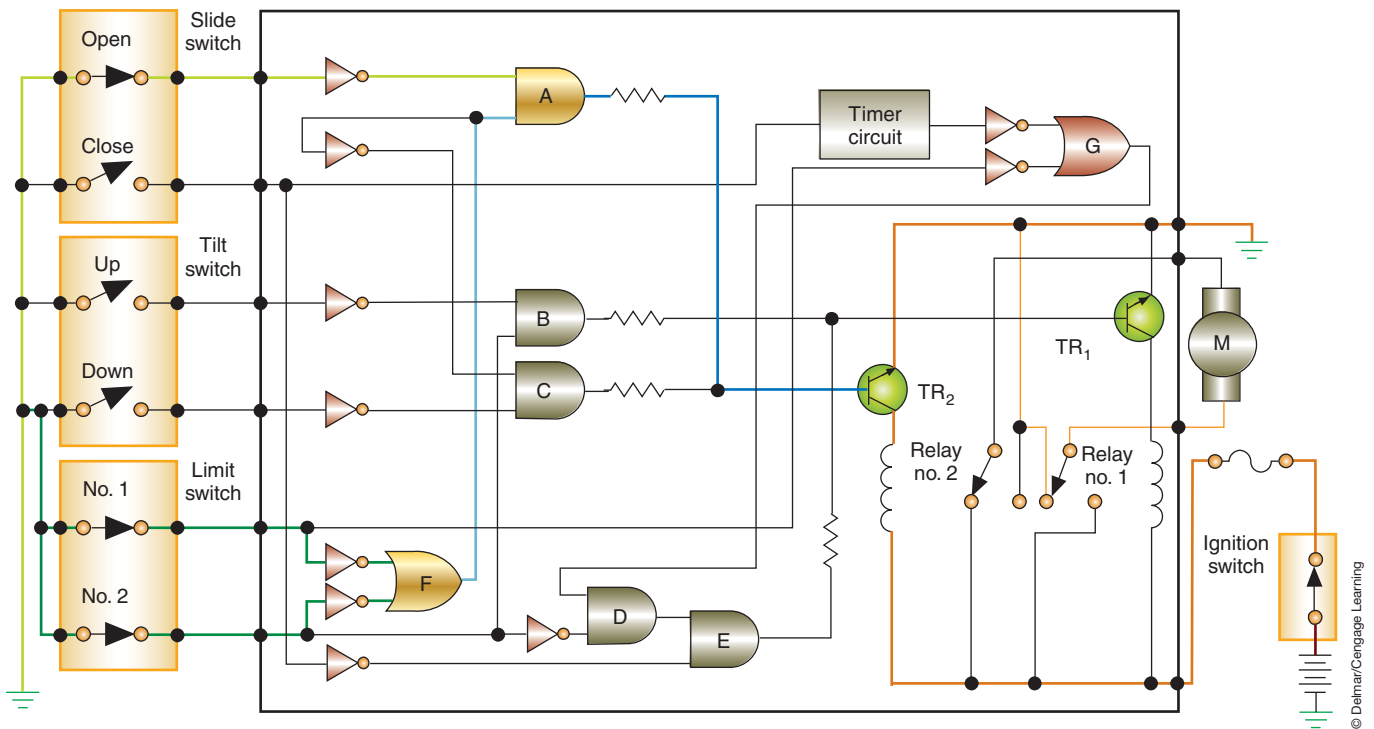
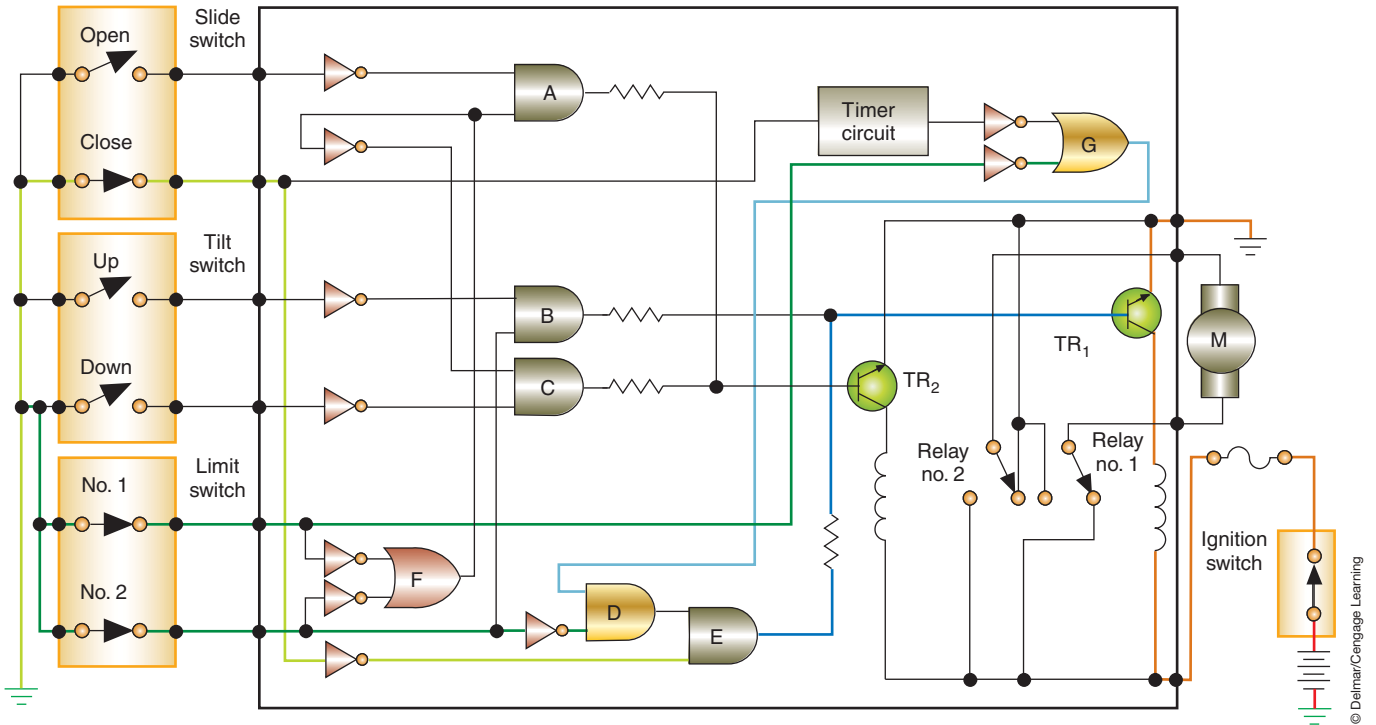


FIGURE 14-82 Circuit operation when the switch is in the OPEN position.

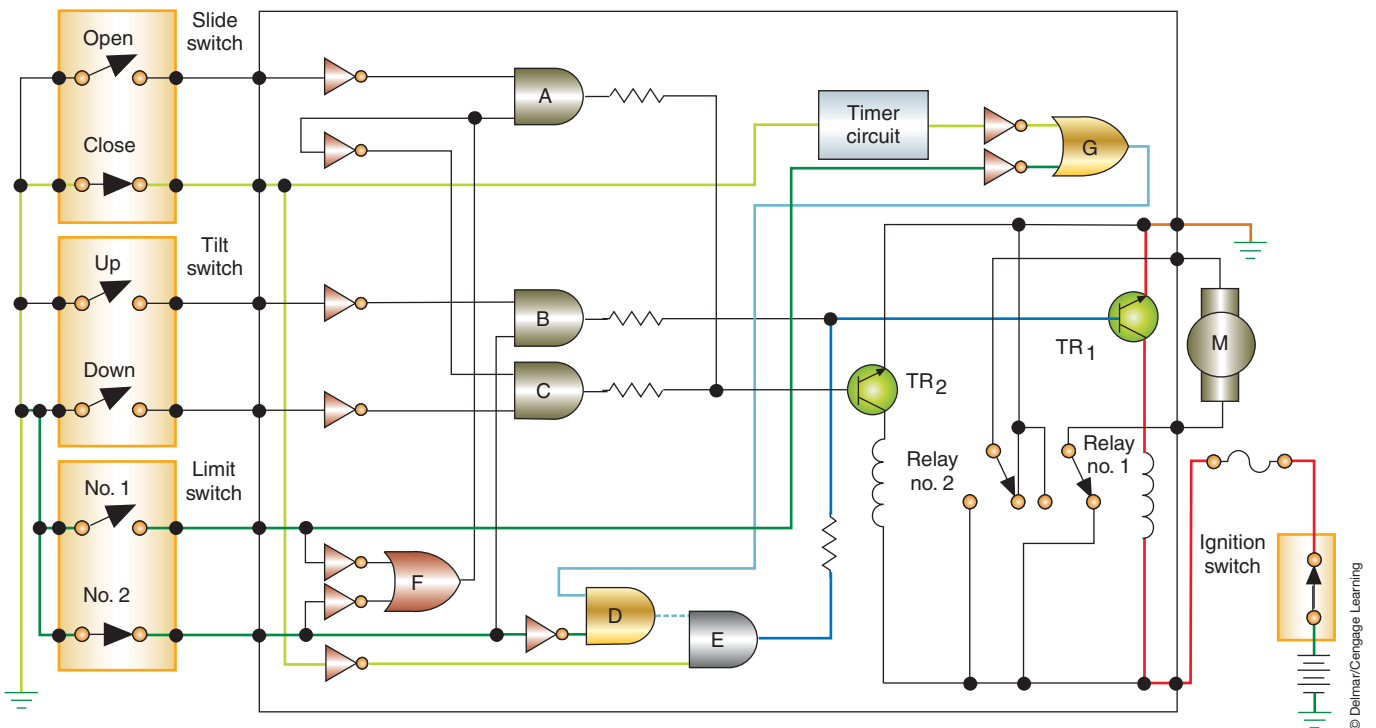
The logic gates of this system operate on the principle of **negative logic**, which defines the most negative voltage as a logical 1 in the binary code. When the slide switch is moved to the OPEN position, either limit switch 1 or both limit switches are closed (Figure 14-82). Limit switches 1 and 2 provide a negative side signal to the OR gate labeled F. The output from gate F is sent to gate A. Gate A is an AND gate, requiring input from gate F and the open slide switch. The output signal from gate A is used to turn on TR<sub>2</sub>. This provides a ground path for the coil in relay 2. Battery voltage is applied to the motor through relay 2; the ground path is provided through the de-energized relay 1. Current is sent to the motor as long as the OPEN switch is depressed. If the OPEN switch is held in this position too long, a clutch in the motor disengages the motor from the drive gear.

Operation of the system during closing depends on how far the sunroof is open. If the sunroof is open more than 7.5 inches and the slide contact is moved to the CLOSE position, an input signal is sent to gate E (Figure 14-83). The other input signal required at gate E is received from the limit switches. The limit switch 1 signal passes through the OR gate G to the AND gate D. Limit switch 2 provides the second signal required by gate D. The output signal from D is the second input signal required by gate E. The output signal from E turns on TR<sub>1</sub>. This energizes relay 1 and reverses the current flow through the motor. The motor will operate until the slide switch is opened or limit switch 2 opens.

If the sunroof is open less than 7.5 inches and the slide switch is placed in the CLOSE position, the timer circuit is activated (Figure 14-84). The CLOSE switch signals the timer and provides an input signal to gate E. Limit switch 1 is open when the sunroof is opened less than 7.5 inches. The second input signal required by gate D is provided by the timer. The timer is activated for 0.5 second. This turns on TR<sub>1</sub> and operates the motor for 0.5 second, or long enough for rotation of the motor to close limit switch 1. When limit switch 1 is closed, the operation is the same as described when the sunroof is closed after it is more than 7.5 inches open.



**FIGURE 14-83** Circuit operation when the switch is in the CLOSE position and the sunroof is open more than 7.5 in. (19 cm).



**FIGURE 14-84** Circuit operation when the switch is in the CLOSE position and the sunroof is open less than 7.5 in. (19 cm).

When the tilt switch is located in the UP position, a signal is imposed on gate B (Figure 14-85). This signal is inverted by the NOT gate and is equal to the value received from the opened number 2 limit switch. The output signal from gate B turns on TR<sub>1</sub>, which energizes relay 1 to turn on the motor. The motor clutch will disengage if the switch is held in the closed position longer than needed.

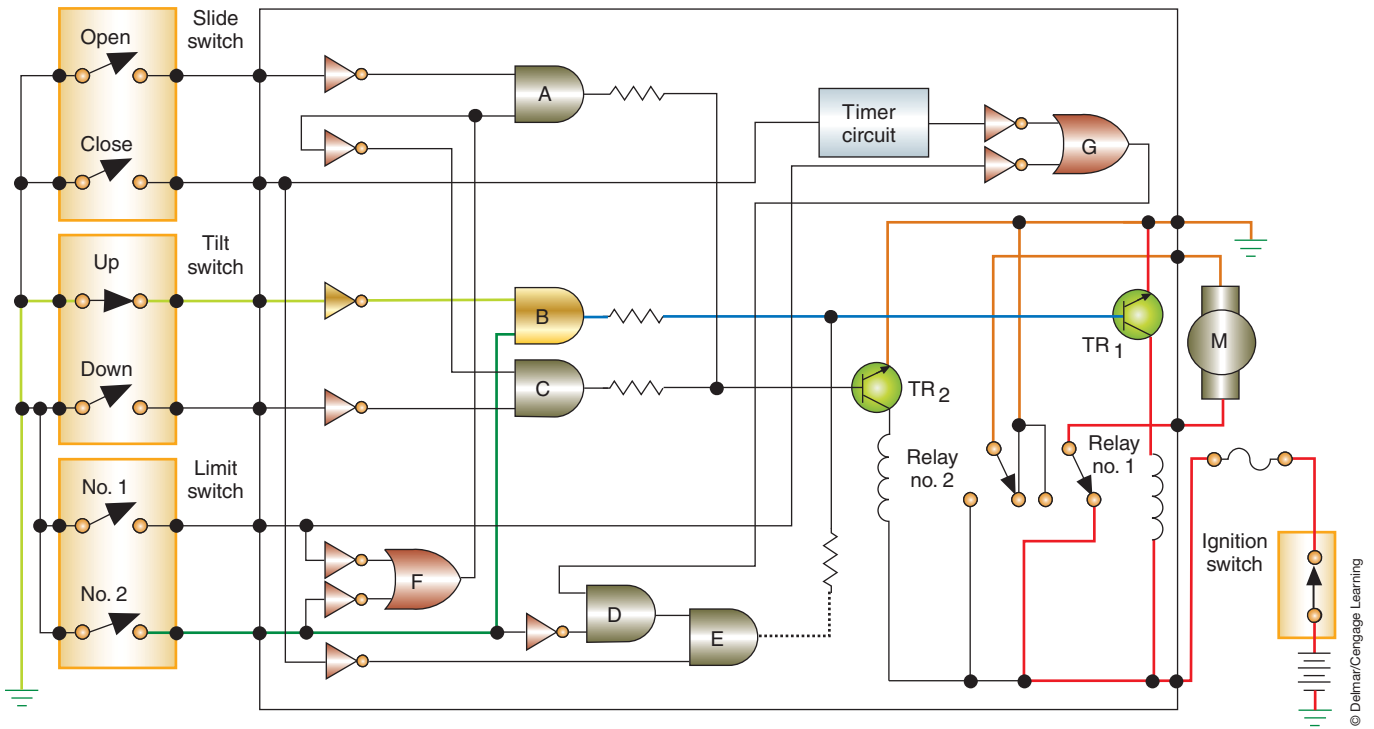


FIGURE 14-85 Circuit operation in the TILT UP position.

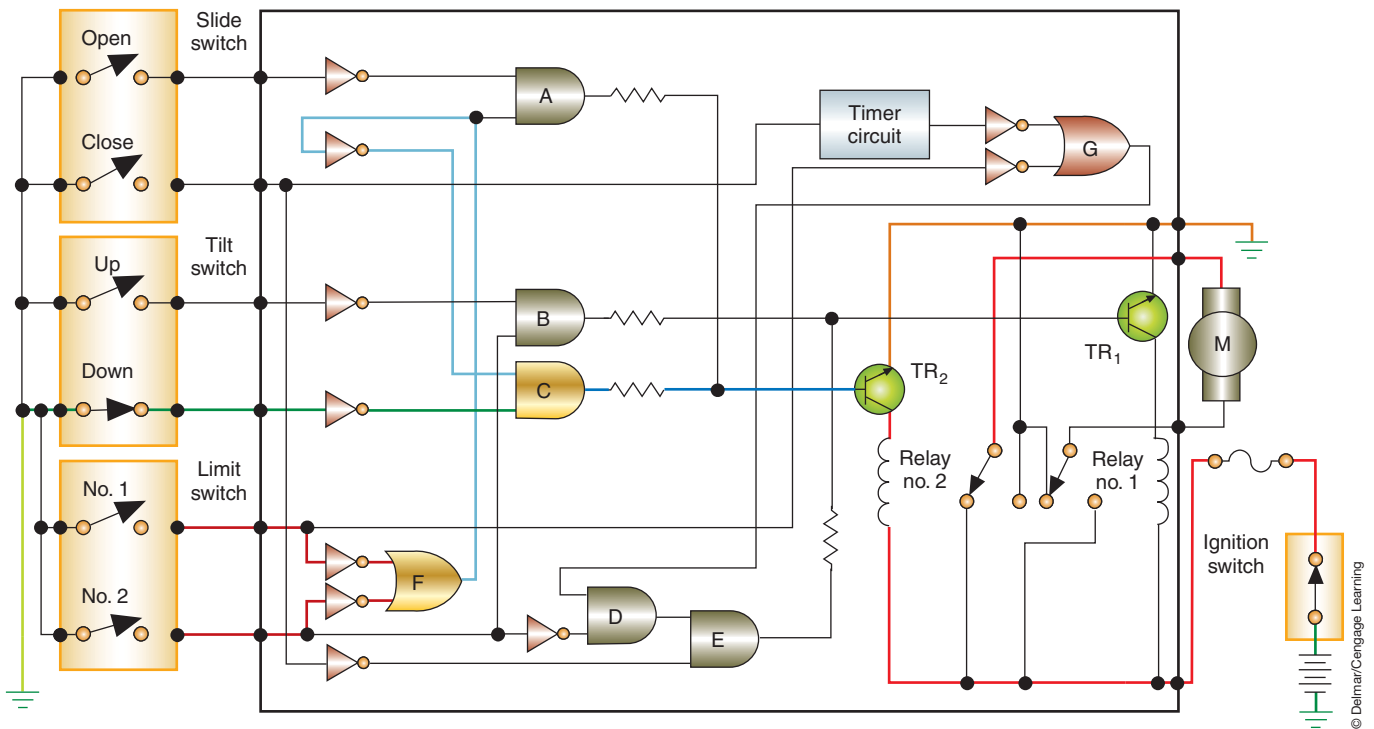


FIGURE 14-86 Circuit operation during TILT DOWN.

When the tilt switch is placed in the DOWN position, a signal is imposed on gate C (Figure 14-86). The second signal to gate C is received from the limit switches (both are open) through gate F. The signal from gate F is inverted by the NOT gate and is equal to that from the DOWN switch. The output signal from gate C turns on  $TR_2$  and energizes relay 2 to lower the sunroof. If the DOWN switch is held longer than necessary, limit switch 1 closes. When this switch is closed, the signals received by gate F are not opposite. This results in a mixed input to gate C and turns off the transistor.

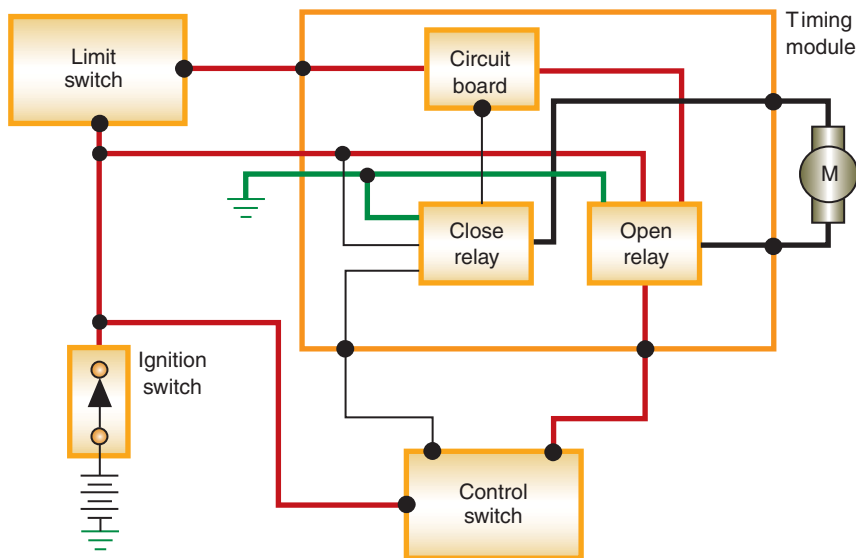


FIGURE 14-87 Block diagram of the GM sunroof.

© Delmar/Cengage Learning

## Electronically Controlled General Motors' Sunroof

See the schematic (Figure 14-87) of the sunroof system used on some GM model vehicles. The timing module uses inputs from the control switch and the limit switches to direct current flow to the motor. Depending on the inputs, the relays will be energized to rotate the motor in the proper direction. When the switch is located in the OPEN position, the open relay is energized, sending current to the motor. The sunroof will continue to retract as long as the switch is held in the OPEN position. When the sunroof reaches its full open position, the limit switch will open and break the circuit to the open relay.

Placing the switch in the CLOSE position will energize the close relay. The current sent to the motor is in the opposite direction to close the sunroof. If the close switch is held until the sunroof reaches the full closed position, the limit switch will open.

## ELECTRONIC HEATED WINDSHIELD

The heated windshield system is designed to melt ice and frost from the windshield three to five times faster than conventional defroster systems (Figure 14-88). The windshield undergoes a special process during manufacturing to allow for current flow through the glass without interfering with the driver's vision.

### There are two basic methods used to make the heated windshield:

1. Use a layer of plastic laminate that is between two layers of glass. The back of the outer layer is fused with a silver and zinc oxide coating. The coating carries the electrical current. Busbars are attached to the coating at the top and bottom of the windshield (Figure 14-89). A sensor is used to check the condition of the windshield coating. If the windshield has a crack or chip that will affect heating (Figure 14-90), the voltage drop across the resistor will indicate this condition to the control module. If the windshield is damaged, the controller will not allow heated windshield operation.
2. Use a layer of resistive coating sprayed between the inner and outer windshield layers. The coating is transparent and does not provide any tint. A sensor is used to indicate if the coating has been damaged. If a chip or crack is not deep enough to penetrate the coating, it will not affect the system operation.

The two systems discussed here are representative of the methods used to heat the windshield.

### Shop Manual

Chapter 14, page 612

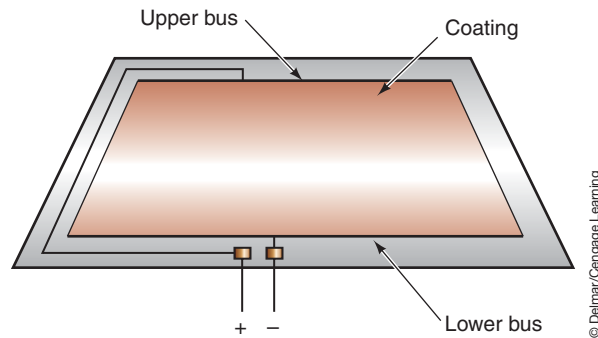
The silver and zinc coating gives the windshield a gold tint.

The film used on the heated windshield will block some radio or microwave signals. This may reduce the effective range of garage door openers and radar detectors.

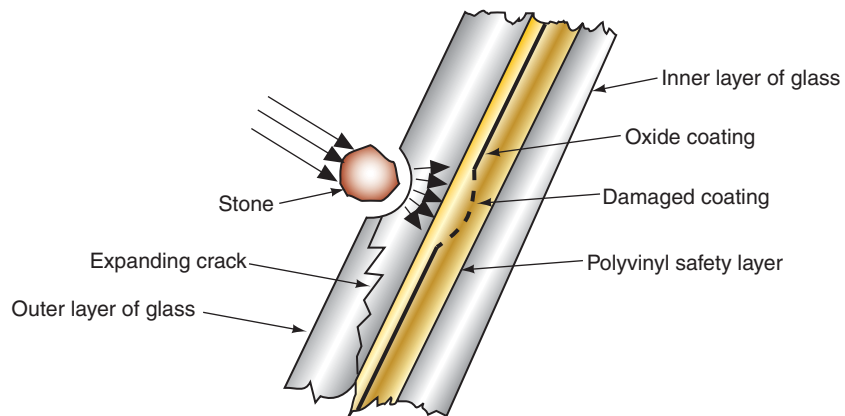




**FIGURE 14-88** The heated windshield removes ice and frost from the windshield in just a few minutes.



**FIGURE 14-89** The power and ground circuits are connected to the silver and zinc coating through busbars.

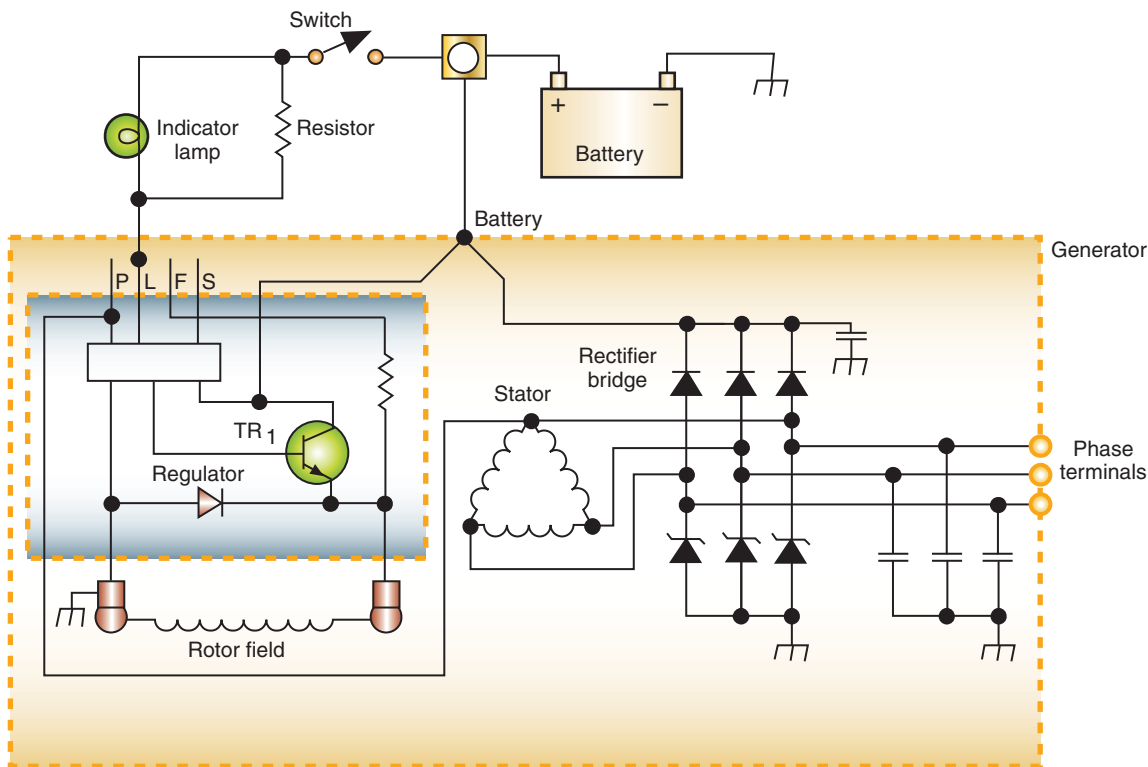


**FIGURE 14-90** An open in the circuit can be caused by a chip or crack in the windshield. A sensor is used to prevent operation if the windshield is damaged.

## General Motors' Heated Windshield

General Motors' heated windshield consists of the following components:

1. The heated windshield: Contains a transparent internal resistive coating that heats when current is applied to it.
2. Special CS 144 generator: There are three special phase terminals to provide AC power to the system's power module (Figure 14-91). The generator can continue to supply its normal DC voltage while AC power is being supplied.



© Delmar/Cengage Learning

**FIGURE 14-91** Schematic of CS 144 alternator used on vehicles equipped with heated windshields. The three terminals provide AC current to the power module.

3. The power module: Converts the AC voltage from the generator to a higher DC voltage for use by the windshield.
4. The control module: Controls the heating cycle and provides automatic shutdown at the end of the time cycle, or if a fault is detected in the system.
5. The control switch.

See the schematic (Figure 14-92) of the GM heated windshield. When the driver activates the system, the control module starts its turn-on sequence. First, it checks that there is more than 11.2 volts present at terminal B6. This assures there will be sufficient voltage to operate other circuits.

The second step for the control module is to check the vehicle's inside temperature. For the system to operate, the temperature must be below 65°F (18°C). Next, the controller checks the windshield sensor to see if there is any damage to the film coating.

If all of these conditions are met, the control module sends a signal to the BCM to increase the engine speed. The BCM passes the request on to the PCM. If the gear selector is in PARK or NEUTRAL, the ECM will increase the idle speed to approximately 1,400 rpm. The PCM will send a signal back to the BCM to indicate that the speed has been increased. When this feedback signal is received, the control module will turn on the power module relays. The power module will draw AC current from the generator. The current is amplified and rectified by the power module, then sent to the windshield. Voltage at the windshield is between 50 and 90 volts.

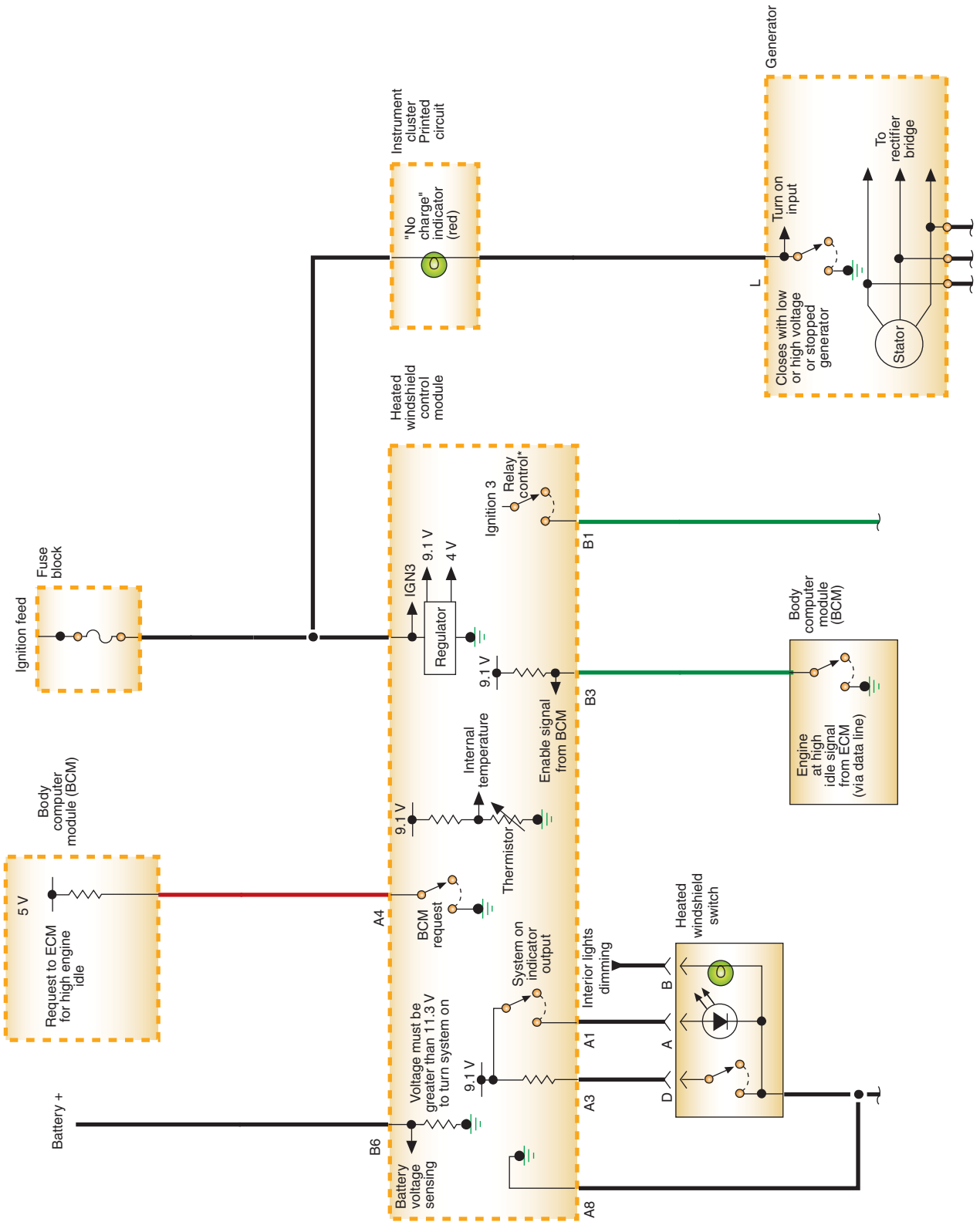
Incorporated into the control module is a timer circuit. When the activation switch is turned on for the first time, the control module will operate the system for 3 minutes. If the switch is pressed again, at the end of the first cycle, it will result in a 1-minute cycle. If the switch is pressed while the cycle is still in operation, the system is turned off.

The BCM and PCM are used to provide certain functions when the system is activated.

## Ford's Heated Windshield

The illustration (Figure 14-93) shows the major components of the Ford heated windshield system. For the system to be activated, the engine must be running and inside temperature must be 40°F or less. When the driver activates the system, the control module shuts off the

For the system to be activated, the engine must be running.



© Delmar/Cengage Learning

FIGURE 14-92 General Motors' heated windshield schematic.

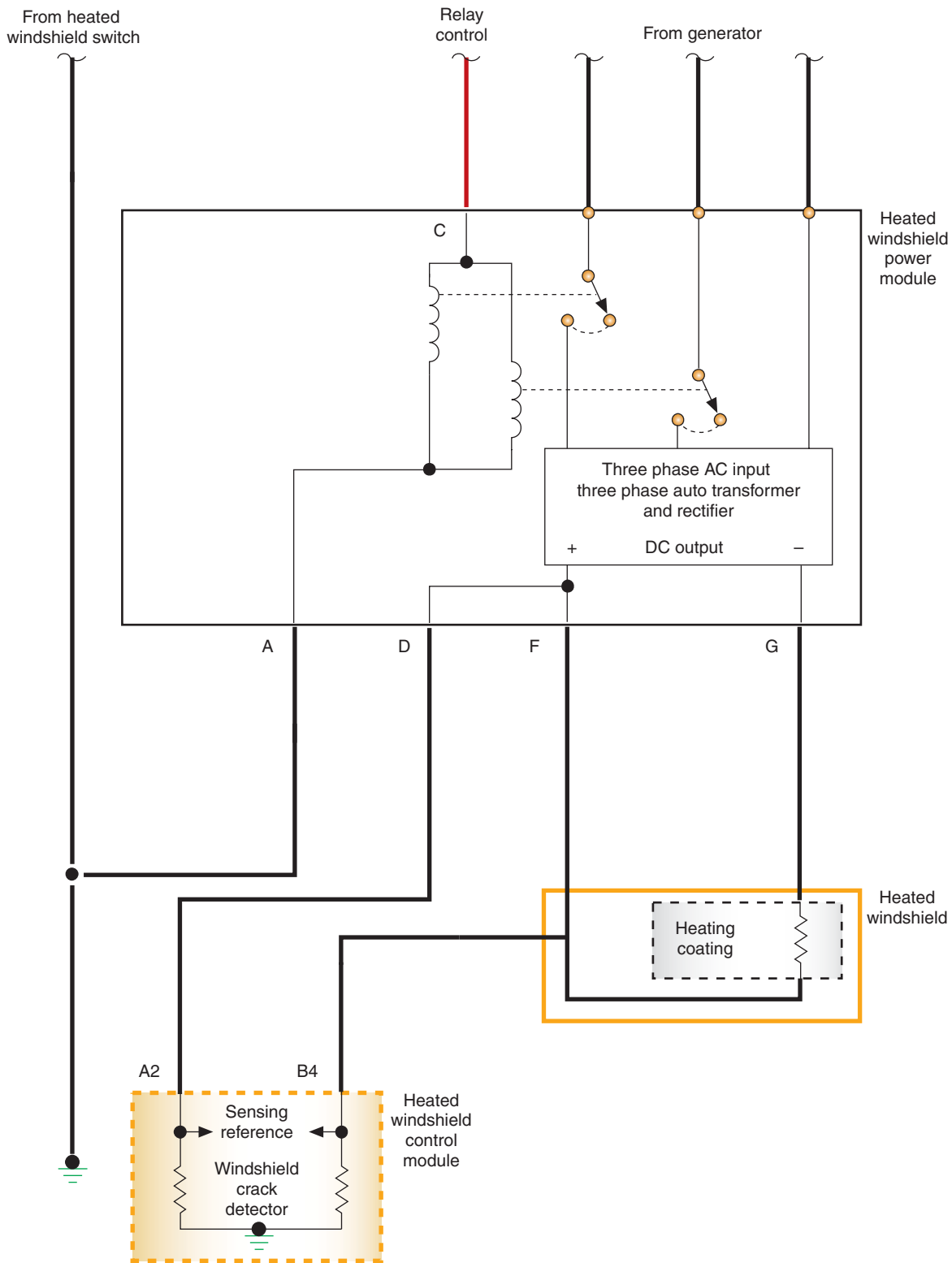
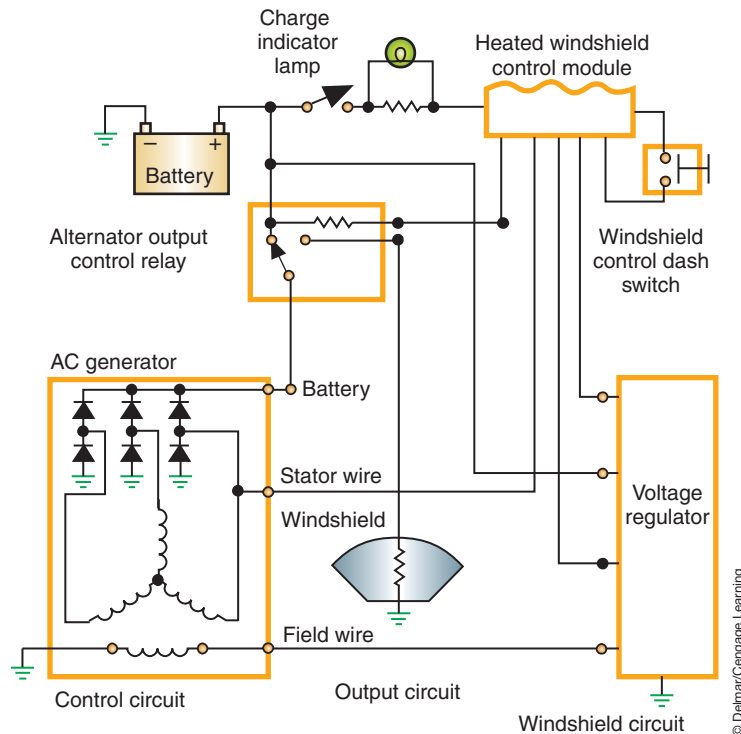


FIGURE 14-92 (continued)

© Delmar/Cengage Learning

voltage regulator and energizes the generator output control relay. This switches the generator output from the electrical system to the windshield circuit. After the switch has been completed, the control module turns on the voltage regulator to restore generator output.

With the generator output disconnected from the battery, battery voltage drops below 12 volts. The voltage regulator attempts to charge the battery by full fielding the generator.



**FIGURE 14-93** Simplified circuit schematic of Ford's heated windshield system.

Because the battery does not receive the generator output, full field voltage reaches 30 to 70 volts. All of the full field power is sent to the windshield.

The control module will monitor the battery voltage and generator output. It will prevent the output from increasing over 70 volts to protect the system. To prevent damage to the battery, if its voltage drops below 11 volts, the control module reconnects the electrical system to the generator.

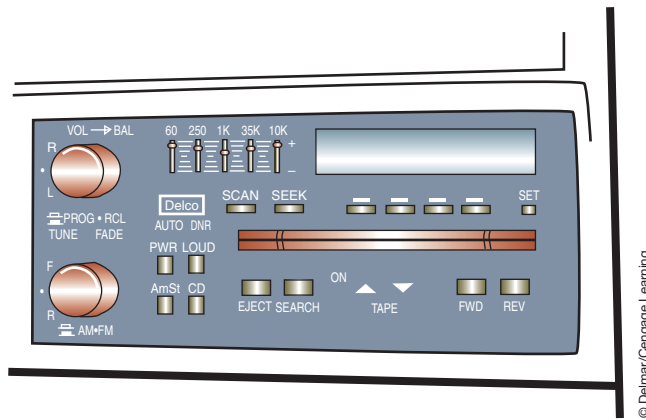
When the system is activated, the control module sends a signal to the EEC controller to increase the idle speed to about 1,400 rpm. If the transmission is placed into a gear selection other than PARK or NEUTRAL, the EEC will return the idle speed to the normal setting.

## VEHICLE AUDIO ENTERTAINMENT SYSTEMS

When radios were first introduced to the automotive market, they produced little more than tinny noise and static. Today's audio sound systems produce music and sound that rivals the best that home sound systems can produce. And with nearly the same or even greater amounts of volume or sound power!

The most common sound system configuration is the all-in-one unit called a receiver. Housed in this unit is the radio tuner, amplifier, tone controls, and unit controls for all functions. These units may also include internal capabilities such as cassette players, compact disc players, digital audiotape players, and/or graphic equalizers. Most will be electronically tuned with a display that shows all functions being accessed/controlled and digital clock functions (Figure 14-94).

Recent developments by the manufacturers have been made to take individual functions (tape, disc, equalizer, control head, tuner, amplifier, etc.) and put them in individual boxes and call them components. This would allow owners greater flexibility in selecting options to suit their needs and tastes (Figure 14-95). Componentizing has allowed greater dash design



**FIGURE 14-94** Radios are actually receivers. They contain the basic elements of a tuner, an amplifier, and a control assembly in one housing and can also contain a tape or CD player.

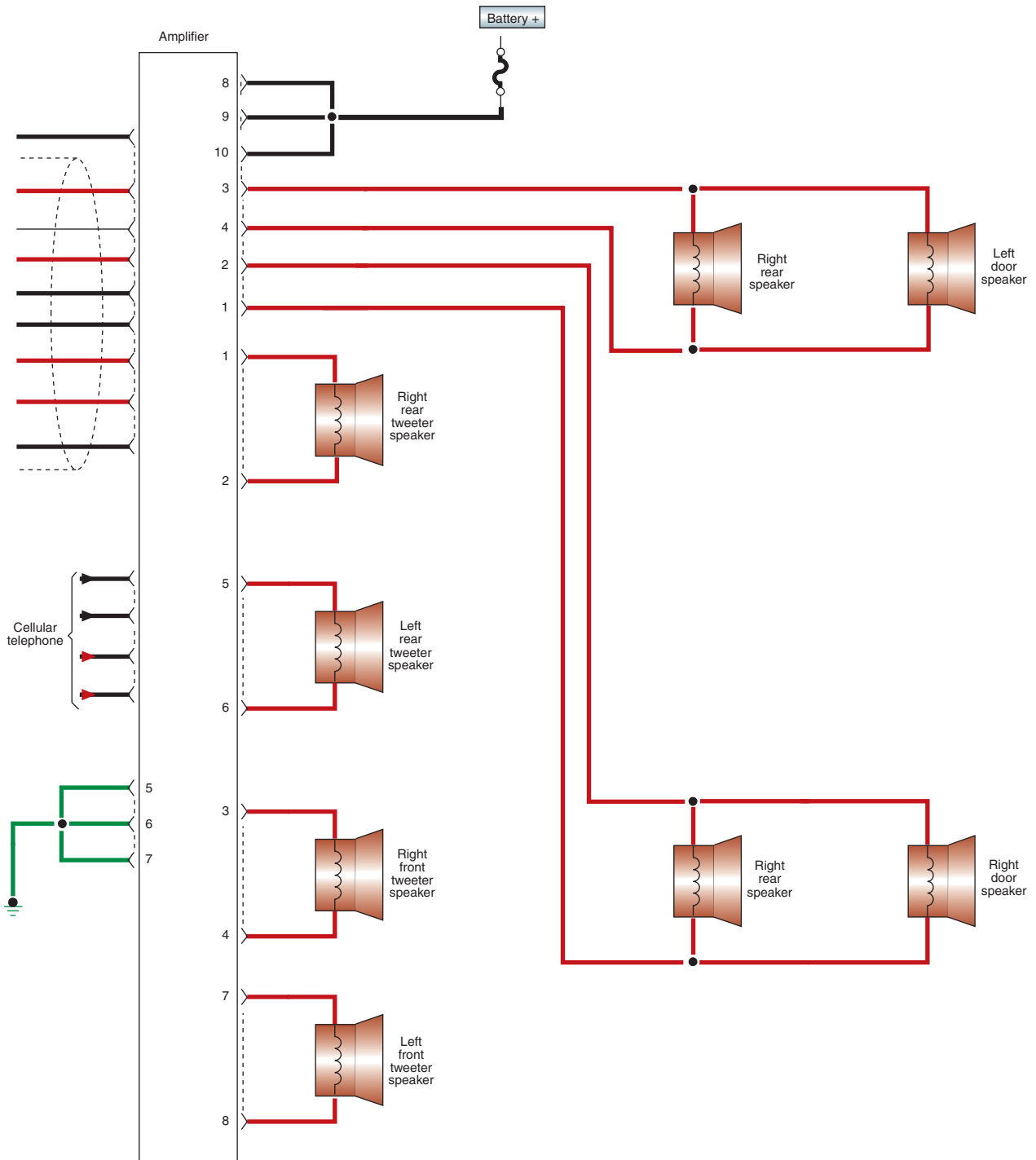


**FIGURE 14-95** Components, like those shown here, allow for more options to the sound system.

flexibility. Some components, such as multiple-CD changers, can be remotely mounted in a trunk area for greater security.

Wiring diagrams for component systems will be more complex (Figure 14-96). In addition to power and audio signal wires, note that some systems will have a serial data wire for microprocessor communication between components for the controlling of unit functions. Some functions are shared and integrated with factory-installed cellular phones, such as radio mute. Some systems allow remote control of functions through a control assembly mounted in the steering wheel or alternate passenger compartment location (Figure 14-97).

The remote controls can be either resistive multiplexed switches or use a supplementary bus system such as LIN. These inputs go to the controlling module. The switches send different voltage signals to the module, corresponding to which switch is pressed. The module responds by sending a request message via the data bus to the radio.



**FIGURE 14-96** Schematic diagram showing the wiring hook-ups for remote-mounted components.

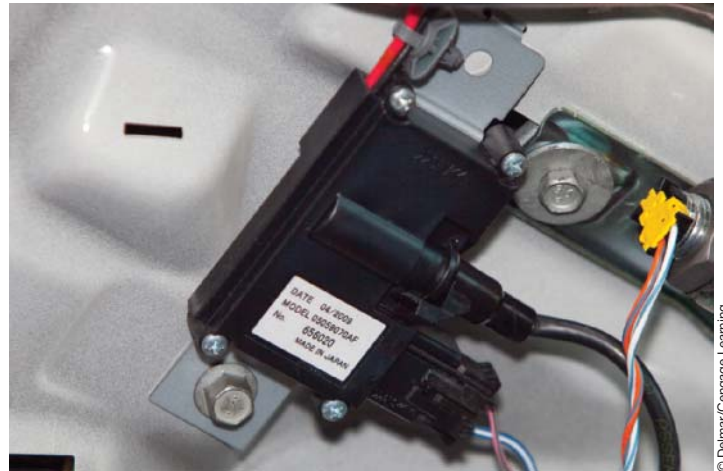
An antenna is needed to collect amplitude modulation (AM) and frequency modulation (FM) radio signal waves. The radio station's broadcast tower transmits electromagnetic energy through the air that induces an AC voltage that averages 50 microvolts in the antenna. The radio receiver processes this AC voltage signal and converts it to an audio output.

Some vehicles have the antenna incorporated into the rear window defogger grid. A rear window defogger/antenna module (Figure 14-98) separates the RF signal used by the





**FIGURE 14-97** Audio system with steering wheel-mounted remote control.



**FIGURE 14-98** Defogger/antenna module.

radio from the electrical current used by the grid. When the radio is turned on, a 12-volt signal is sent to the defogger/antenna module (Figure 14-99). A coaxial cable from the module provides the AM and FM tuners the RF signal input. Usually the top grid lines are unheated. These are used to receive the AM signals. The heated grid lines are used to receive the FM signals.

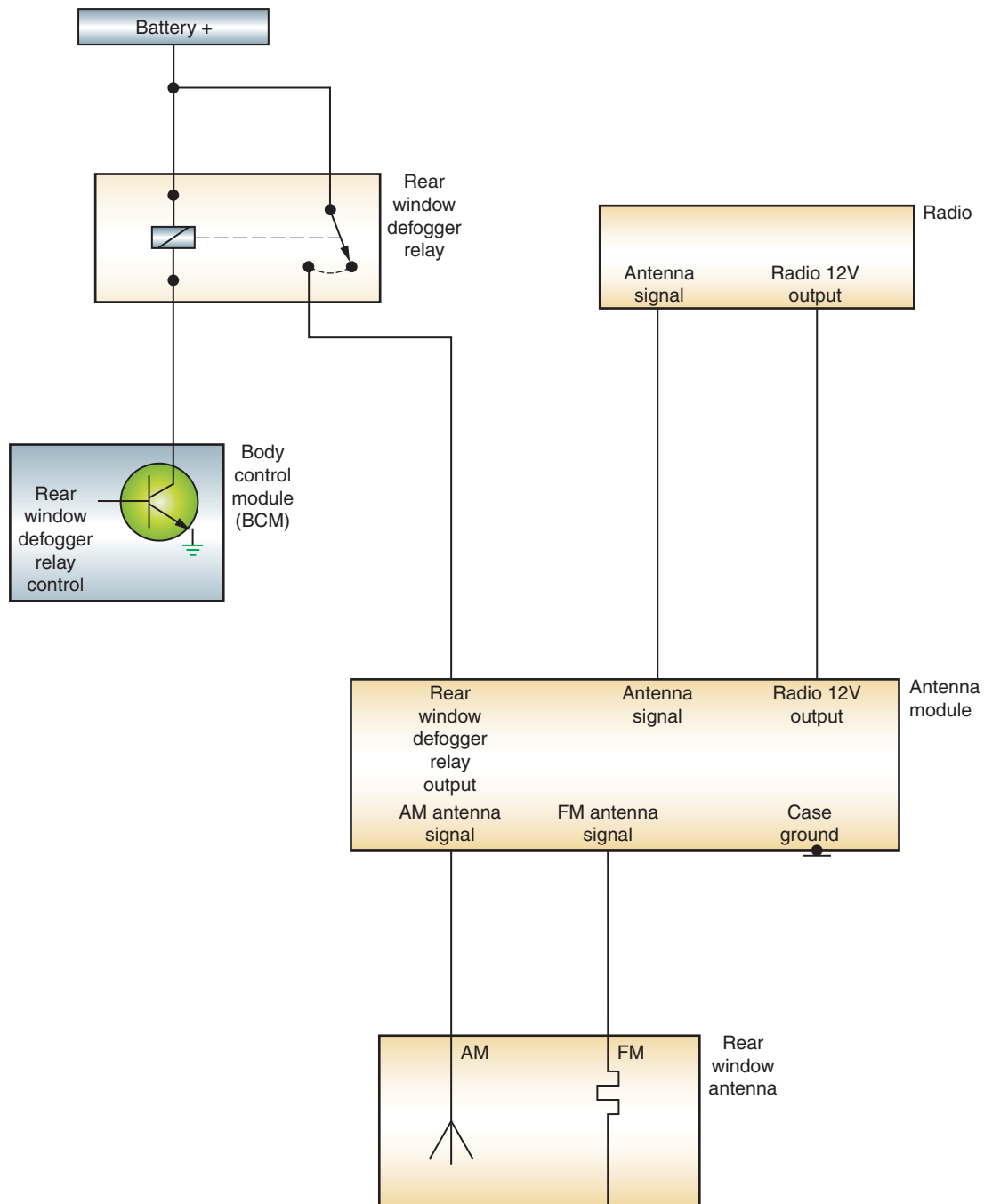
Sound system amplifiers can be either remotely mounted or integrated with the speakers. Most remotely mounted amplifiers are connected to the data bus. This allows for configuration to match it to the vehicle. Amplifier configuration includes amplification output power, the number of output channels, and the equalizer curve.

Functions that are supported by data bus inputs to the amplifier include speed-proportional volume increase, designating speakers for shared audio functions, and fixed audio output if an amplified speaker system is used.

Integrated amplifiers are mounted in the speakers. Power to the amplifiers is supplied through the amplifier relay. When the radio is turned on, 12 volts are supplied to energize the relay.

Reception to the radio receiver from the antenna can be interfered with by noise resulting from RFI. This is especially true of the AM band. The noise is picked up by the radio receiver and amplified through the audio circuits. The FM band is susceptible to EMI, but usually is not as noticeable compared to AM. Control of RFI and EMI noise is done by proper radio antenna base, proper radio receiver, proper engine-to-body ground, and proper heater core grounds. In addition, resistor-type spark plugs and radio suppression secondary ignition wiring are used. The radio itself will also have internal suppression devices, such as capacitors that shunt AC noise to ground and slow sudden changes of voltage in a circuit. Some systems will use a **radio choke**. The choke is a winding of wire. In a DC circuit the choke acts like a short, but in an AC circuit it represents high resistance. The choke blocks the noisy AC current but allows the DC current to pass normally.

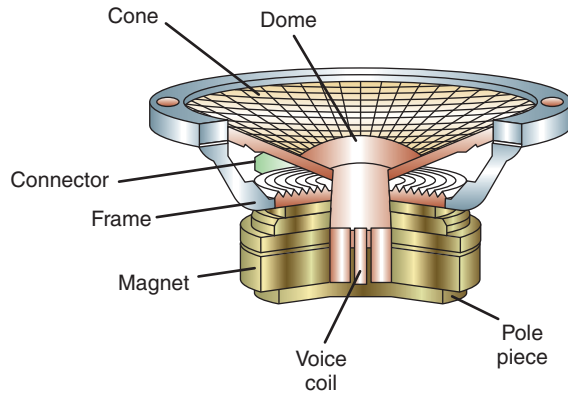
Speakers turn the electrical energy from the radio receiver amplifier into acoustical energy. The acoustical energy moves air to produce sound. A speaker moves the air using a permanent magnet and electromagnet (Figure 14-100). The electromagnet is energized when the amplifier delivers current to the voice coil at the speaker. The coil forms magnetic poles that cause the voice coil and speaker cone to move in relation to the permanent magnet. The current to the speaker is rapidly changing AC current that results in the speaker cone moving rapidly in and out and producing sound.



© Delmar/Cengage Learning

**FIGURE 14-99** Rear window defogger/antenna circuit.

Since one speaker cannot reproduce the entire hearing frequency range of approximately 20 Hz to 20 KHz, speakers are designed to reproduce only parts of the desired frequency. Large speakers, called **woofers**, produce the low frequencies of midrange and bass better than small speakers. Smaller speakers, called **tweeters**, produce the high frequencies of treble better than large speakers. Coaxial speakers have two separate speakers combined in one speaker frame and cover a broader frequency range than a single-cone speaker. Subwoofer speakers can be coupled with the coaxial speaker (or a separate tweeter and midrange speaker) to cover the hearing range and maximize sound quality.



**FIGURE 14-100** Speaker construction.

## Satellite Radio

**Satellite radios** are the latest technology in radios (Figure 14-101). Satellite radio provides several commercial-free music and talk show channels using orbiting satellites to provide a digital signal. An in-vehicle receiver receives the digital signal, which travels to the conventional vehicle radio as an auxiliary audio input and plays through the normal speaker system. In this case the satellite radio function becomes an additional mode of the radio. Satellite radio operation is available only when the owner purchases the subscription service.

**AUTHOR'S NOTE:** If all satellite signal is lost, the radio becomes unlike the loss of an AM or FM signal where some static or hiss may be heard.

The satellite digital audio receiver (SDAR) is an additional audio receiver that is installed separate from the vehicle's radio. The satellite's signal is processed by an SDAR, which provides an input signal to the conventional radio over dedicated circuits for right and left channels. The usual radio controls for mode selection and tuning are used to the SDAR. This allows the radio controls to operate the SDAR. Any text information such as channel



**FIGURE 14-101** Satellite radio system.



© Delmar/Cengage Learning

**FIGURE 14-102** Satellite radio antenna.

numbers, track, and artist that the stations transmit is sent to the radio over the data bus and displayed on the radio screen.

The SDAR signals the satellite antenna located on the centerline of the roof (Figure 14-102), and the tuning of the antenna is calibrated to use the ground plane of the vehicle. Signal reception is possible only when the antenna and the satellite are in a direct line. Obstacles such as buildings, overpasses, and tunnels may temporarily disrupt the signal. A buffer is included that prevents brief interruptions when the vehicle passes under bridges.

Some radios have only one audio input. In order to add multiple audio sources such as SDAR, CD/DVD, and hands-free cell phone, a multiplexer may be used. The **multiplexer** acts as an electronic switch to switch between the different audio sources. Depending on which source requires use of the system, the multiplexer will make the switch and send the output to the radio.

## DVD SYSTEMS

There are several digital video disc/video entertainment systems (DVD/VES) available on today's vehicles. Most DVD systems display the video on a flip-down, roof-mounted monitor (Figure 14-103) or on a monitor attached to the back of the front seats (Figure 14-104). Most



© Delmar/Cengage Learning

**FIGURE 14-103** Flip-down, roof-mounted, DVD monitor.



© Delmar/Cengage Learning

**FIGURE 14-104** DVD monitor located in the seat back.

will play the audio through the vehicle's regular audio system. If a DVD is playing, the audio system automatically switches to a "surround sound" mode that is biased toward the rear of the vehicle. In addition, remote control and auxiliary input jacks that will permit the display of video cameras and video games may also be included.

When headphones are supported, the speakers may play audio from one source while the headphones can play audio from another source. If the headphones and the radio are playing in the same mode, the radio is the master of the system. Headphones use either a 900-MHz signal or infrared. The headphones enable rear-seat occupants to listen to audio while front-seat occupants listen to cassettes, CDs, or the radio on the front speakers. The headphones receive their signals from the radio or the CD changer. Two separate channels are used to minimize interference. If another audio/video system is within range, the headphones automatically switch to the strongest channel.

## **HANDS-FREE CELLULAR TELEPHONE**

The hands-free cellular telephone system can use different wireless technologies. Bluetooth™ wireless technology is discussed here. As discussed in Chapter 11, this technology allows for communication between modules. In this case, the communication is between a compatible cellular telephone and the vehicle's on-board receiver. The system communicates with a cell phone that is anywhere within the vehicle. The system recognizes several cell phones. Each cell phone is given an identification number, name, and priority by the user during the setup process. The assigning of this information pairs the cell phone to the system. The pairing process stores the cell phone's IP address in the hands-free module (HFM) and the HFM's IP address into the cell phone.

The system uses voice recognition technology to control operation. When a programmed cell phone is within range of the HFM, communication between the two components is established. When a cell phone call is initiated, the voice is broadcast through the radio speakers. If any other audio device is using the speakers at that time, the hands-free system automatically overrides it.

When the HFM broadcasts a data bus message that hands-free operation is about to be initiated, the vehicle radio stores its current volume level and mode. The radio then switches to the stored hands-free volume level. The amplifier fades all of the speakers and then transmits the hands-free audio through the speakers. When the HSM broadcasts a data bus message that the cell phone call has been terminated, the radio stores the HFM volume level and



returns to the previous radio mode and volume level. At this time, the amplifier returns all speakers to their previous audio level.

A dual-element microphone module (DEMM) is located in either the dash, center console, or rearview mirror. The DEMM consists of microphone elements and electrical circuitry that includes a preamplifier network. The DEMM is capable of tuning the microphone frequency response to improve the voice recognition function.

## NAVIGATION SYSTEMS

Many manufacturers offer **navigational systems** as an option on their higher line vehicles (Figure 14-105). These systems use satellites to direct drivers to their desired destinations. Many navigational systems are integrated in the vehicle radio. Regardless of the display method, most navigational systems use a GPS antenna, to determine the vehicle's location by latitude and longitude coordinates, and a gyroscope to determine vehicle turns. Usually map data, provided on a DVD, and navigation information are displayed on a thin film transistor, liquid crystal display (TFT, LCD) color screen. Voice prompts can be sent through the audio system speakers.

Most systems will provide at least some of the following features:

- Full-screen map display.
- Vehicle location and route guidance.
- Turn-by-turn distance in feet or meters.
- Points of interest en route.
- The storage of favorite routes and locations.
- The storage of recent routes.

During most conditions, the gyroscope, data bus information, and the map data locate the vehicle on the displayed map. If the vehicle is traveling in an unmapped area, the system uses the GPS data.

The navigational system can also be incorporated into a vehicle-tracking system. If the vehicle is stolen, its whereabouts can be tracked using the satellite. If the navigational system is tied to the hands-free cell phone system, the driver can get on-road assistance in the event of a problem. For example, if the driver locks the keys in the vehicle, he can call the assistance line and the representative can send a signal to unlock the doors. If the air bags deploy, the system can automatically send a signal of this event. A representative from the tracking subscription company will attempt to get in touch with the vehicle occupants to see if assistance is required. Emergency personnel can be dispatched because the satellite system informs the representative of the exact location of the vehicle.



### A BIT OF HISTORY

Radios were introduced in cars by Daimler in 1922. Cars were equipped with Marconi wireless receivers.



© Delmar/Cengage Learning

FIGURE 14-105 Navigational system monitor and controls.

## SUMMARY

---

- Automotive electrical horns operate on an electromagnetic principle that vibrates a diaphragm to produce a warning signal.
- Horn switches are either installed in the steering wheel or as a part of the multifunction switch. Most horn switches are normally open switches.
- Horn switches that are mounted on the steering wheel require the use of sliding contacts. The contacts provide continuity for the horn control in all steering wheel positions.
- The most common type of horn circuit control is to use a relay.
- Most two-speed windshield wiper motors use permanent magnet fields whereby the motor speed is controlled by the placement of the brushes on the commutator.
- Some two-speed and all three-speed wiper motors use two electromagnetic field windings: series field and shunt field. The two field coils are wound in opposite directions so that their magnetic fields will oppose each other. The strength of the total magnetic field will determine at what speed the motor will operate.
- Park contacts are located inside the wiper motor assembly and supply current to the motor after the switch has been turned to the PARK position. This allows the motor to continue operating until the wipers have reached the PARK position.
- Intermittent wiper mode provides a variable interval between wiper sweeps and is controlled by a solid-state module.
- Systems that have a depressed-park feature use a second set of contacts with the park switch, which are used to reverse the rotation of the motor for about 15 degrees after the wipers have reached the normal PARK position.
- Blower fan motors use a resistor block that consists of two or three helically wound wire resistors that are connected in series to control fan speed.
- The blower motor circuit includes the control assembly, blower switch, resistor block, and blower motor.
- Electric defoggers heat the rear window by means of a resistor grid.
- Electric defoggers may incorporate a timer circuit to prevent the high current required to operate the system from damaging the battery or charging system.
- The electrically controlled mirror allows the driver to position the outside mirrors by use of a switch that controls dual-drive, reversible PM motors.
- Power windows, seats, and door locks usually use reversible PM motors, whereby motor rotational direction is determined by the direction of current flow through the switch wipers.
- Cruise control is a system that allows the vehicle to maintain a preset speed with the driver's foot off the accelerator.
- The cruise control module energizes the supply and vent valves to allow manifold vacuum to enter the servo. The servo moves the throttle to maintain the set speed. The vehicle speed is maintained by balancing the vacuum in the servo.
- The memory seat feature allows the driver to program different seat positions that can be recalled at the push of a button.
- The easy exit feature is an additional function of the memory seat that provides for easier entrance and exit of the vehicle by moving the seat all the way back and down.
- Antitheft systems are deterrent systems designed to scare off would-be thieves by sounding alarms and/or disabling the ignition system.
- The antitheft control module monitors the switches. If the doors or trunk are opened or the key cylinders are rotated, the module will activate the system.
- The immobilizer system acts as an engine disable system by using an ignition key that has a transponder.

## TERMS TO KNOW

Armed  
Child safety latch  
Clockspring  
Cruise control  
Depressed-park  
Diaphragm  
Electrochromic mirrors  
Express down  
Express up  
Grid  
Immobilizer system  
Keyless start system  
Multiplexer  
Navigational systems  
Negative logic  
Park contacts  
Radio choke



## TERMS TO KNOW

(continued)

Resistor block

Satellite radios

Sector gear

Trimotor

Tweeters

Window regulator

Woofers

## SUMMARY

- Automatic door locks is a passive system used to lock all doors when the required conditions are met. Many automobile manufacturers are incorporating the system as an additional safety and convenience feature.
- The keyless entry system allows the driver to unlock the doors or the deck lid from outside the vehicle without the use of a key.
- The heated windshield system is designed to melt ice and frost from the windshield three to five times faster than conventional defroster systems.
- Vehicle audio entertainment systems are generally only a single component (receiver). Recently, manufacturers have been developing multiple components (tuner, amplifier, control head, etc.) to allow for greater flexibility.
- Some audio component systems utilize a serial data line to provide for communication and control of functions between those components.

## REVIEW QUESTIONS

### Short-Answer Essays

1. Explain the operation of the immobilizer system.
  2. Explain the basic operating principles of the electronic cruise control system.
  3. Describe the operation of a relay-controlled horn circuit.
  4. Explain how brush placement determines the speed of a two-speed, permanent magnet motor.
  5. How do wiper motor systems that use a three-speed, electromagnetic motor control wiper speed?
  6. List and describe the safety modes incorporated into electronic cruise control systems.
  7. List the main components of common antitheft systems.
  8. Explain two methods that the memory seat control module uses to determine seat position.
  9. Describe the operation of electric defoggers.
  10. Briefly explain the principles of operation for power windows.
3. Horn switches that are mounted on the steering wheel require the use of \_\_\_\_\_ to provide continuity in all steering wheel positions.
  4. The \_\_\_\_\_ feature is an additional function of the memory seat that provides for easier entrance and exit of the vehicle.
  5. The \_\_\_\_\_ acts as a switch to change between different active sources.
  6. The generator in the General Motors heated windshield system provides \_\_\_\_\_ power to the system's power module.
  7. In the Ford-style heated windshield system, the voltage regulator \_\_\_\_\_ the generator to supply voltage to the windshield.
  8. Most blower motor fan speeds are controlled through a \_\_\_\_\_ that is wired in series to the fan motor.
  9. Electric defoggers operate on the principle that when electrons are forced to flow through a \_\_\_\_\_, heat is generated.
  10. Radio receiver units usually contain at least the following: an \_\_\_\_\_, a \_\_\_\_\_, and function \_\_\_\_\_.

### Fill in the Blanks

1. Electrical accessories provide for additional \_\_\_\_\_ and \_\_\_\_\_.
2. The \_\_\_\_\_ is a thin, flexible, circular plate that is held around its outer edge by the horn housing, allowing the middle to flex.

## MULTIPLE CHOICE

- Sound from the horn is generated by:
  - Heat causing the diaphragm to vibrate.
  - Vibrating a column of air.
  - Pulse-width modulating of the horn relay.
  - All of the above.
- The horn circuit is being discussed.

*Technician A* says if the circuit does not use a relay, the horn switch carries the total current requirements of the horns.

*Technician B* says most systems that use a relay have battery voltage present to the lower contact plate of the horn switch and the switch closes the path for the relay coil.

Who is correct?

  - A only
  - B only
  - Both A and B
  - Neither A nor B
- Electronic cruise control systems are being discussed.

*Technician A* says if the voltage signal from the VSS drops below the low comparator value, the control module energizes the vent valve solenoid.

*Technician B* says if the VSS signal is greater than the high comparator value, the control module energizes the supply solenoid valve.

Who is correct?

  - A only
  - B only
  - Both A and B
  - Neither A nor B
- Electronic cruise control is being discussed.

*Technician A* says that the electronic cruise control system offers more precise speed control than the electromechanical system.

*Technician B* says that the throttle position sensor is used to provide smooth throttle changes while the cruise control is engaged.

Who is correct?

  - A only
  - B only
  - Both A and B
  - Neither A nor B
- Memory seats are being discussed.

*Technician A* says the power seat and memory seat functions can only be operated when the transmission is in the PARK position.

*Technician B* says when the seat is moved from its memory position, the module stores the number of pulses and direction of movement in memory.

Who is correct?

  - A only
  - B only
  - Both A and B
  - Neither A nor B
- The operation of Toyota's electronically controlled sunroof is being discussed.

*Technician A* says that it is not necessary to understand logic gate operation to understand the control of the sunroof.

*Technician B* says the movement of the sunroof is controlled by a motor that operates a drive gear.

Who is correct?

  - A only
  - B only
  - Both A and B
  - Neither A nor B
- The keyless entry system is being discussed.

*Technician A* says an additional function of the system is that the deck lid lock can be released by pressing the 5-6 button.

*Technician B* says a second code can be entered into the system.

Who is correct?

  - A only
  - B only
  - Both A and B
  - Neither A nor B
- The heated windshield system is being discussed.

*Technician A* says if the windshield has a crack or chip that will affect heating, the voltage drop across the resistor will indicate this condition to the control module.

*Technician B* says if the windshield is damaged, the controller reduces the voltage to the windshield to 20 volts.

Who is correct?

  - A only
  - B only
  - Both A and B
  - Neither A nor B
- Which statement about permanent magnet wiper motors is true?
  - The more armature windings between the high-speed and common brushes results in less magnetism in the armature and lower CEMF.
  - The lower the CEMF in the armature, the greater the armature current.
  - The fewer windings between the low-speed and common brushes results in increased magnetism and higher CEMF.
  - All of the above.
- Technician A* says the master control switch for power windows provides the overall control of the system.

*Technician B* says current direction through the power seat motor determines the rotation direction of the motor.

Who is correct?

  - A only
  - B only
  - Both A and B
  - Neither A nor B

# Chapter 15

## PASSIVE RESTRAINT SYSTEMS

### UPON COMPLETION AND REVIEW OF THIS CHAPTER, YOU SHOULD BE ABLE TO:

- Explain the purpose of passive restraint systems.
- Describe the basic operation of passive seat belt systems.
- Describe the common components of an air bag system.
- List the components and explain the function of the air bag module.
- Describe the function of the clockspring.
- Explain the functions of the diagnostic module used in air bag systems.
- List and describe the operation of the different types of air bag system sensors.
- List the sequence of events that occur during air bag deployment.
- Describe normal operation of the air bag system warning light.
- Describe the operation of a hybrid inflator module, and explain the advantages of this type of module.
- Explain the function of multistage air bags.
- Explain the function of the side-impact air bags and describe the locations of the modules and sensors.
- Describe the operation and purpose of factory-installed air bag on/off switches.
- Explain the procedure required to install air bag deactivation kits and retrofit on/off switches.
- Describe the purpose and operation of seat belt pretensioners.
- Describe the function of occupant classification systems (OCS).

### INTRODUCTION

Federal regulations have mandated the use of automatic passive restraint systems in all vehicles sold in the United States after 1990. Passive restraint systems operate automatically, with no action required on the part of the driver or occupant. Two- or three-point automatic seat belt and air bag systems are currently offered as a means of meeting this requirement.

In this chapter, you will learn the operation of the automatic passive restraint and air bag systems. The safety of the driver and/or passengers depends on the technician properly diagnosing and repairing these systems. As with all electrical systems, the technician must have a basic understanding of the operation of the restraint system before attempting to perform any service.

There are many safety cautions associated with working on air bag systems. Safe service procedures are accomplished through proper use of the service manual and by understanding the operating principles of these systems.

In a two-point system, the occupant must manually lock the lap belt.

## PASSIVE SEAT BELT SYSTEMS

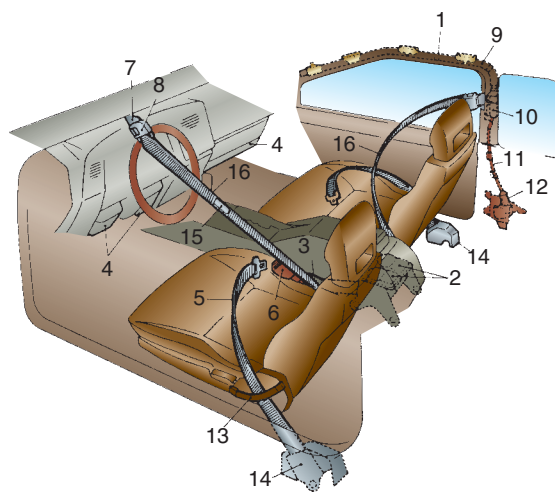
The passive seat belt system automatically puts the shoulder and/or lap belt around the driver or occupant (Figure 15-1). The automatic seat belt system operates by means of DC motors that move the belts by means of **carriers** on tracks (Figure 15-2). The carriers are attached to the shoulder anchor to move or carry the anchor from one end of the track to the other.

One end of the seat belt is attached to the carrier; the other end is connected to the **inertia lock retractors** (Figure 15-3). Inertia lock retractors use a pendulum mechanism to lock the belt tightly during sudden movement. When the door is opened, the outer end of the shoulder harness moves forward (to the A-pillar) to allow for easy entry or exit (Figure 15-4). When the door is closed and the ignition switch is placed in the RUN position, the motor moves the outer end of the harness to the locked position in the B-pillar (Figure 15-5).

The automatic seat belt system uses a control module to monitor operation (Figure 15-6). The monitor receives inputs from door ajar switches, limit switches, and the emergency release switch.

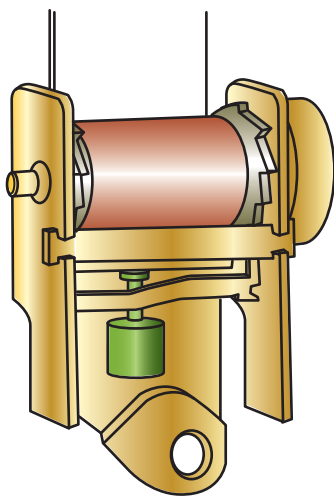


**FIGURE 15-1** Passive automatic seatbelt system operation.

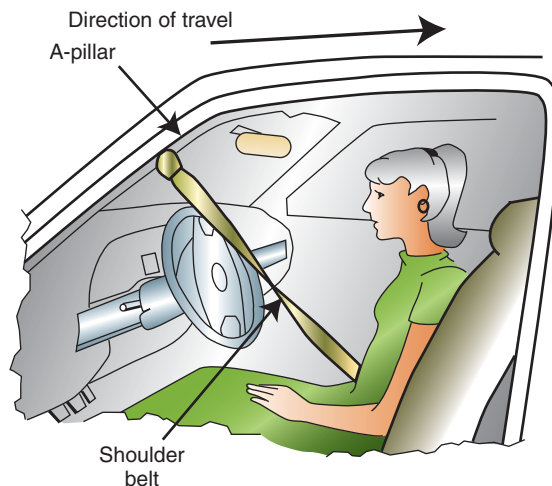


- 1 Rail and motor assembly
- 2 Emergency locking retractor assembly
- 3 Belt guide
- 4 Knee panel
- 5 Outer belt assembly (manual tap belt)
- 6 Inner belt assembly (manual lap belt)
- 7 Shoulder anchor
- 8 Emergency release buckle
- 9 Rail
- 10 Locking device
- 11 Tube
- 12 Motor
- 13 Belt holder
- 14 Emergency locking retractor assembly (manual lap belt)
- 15 Caution label
- 16 Shoulder belt

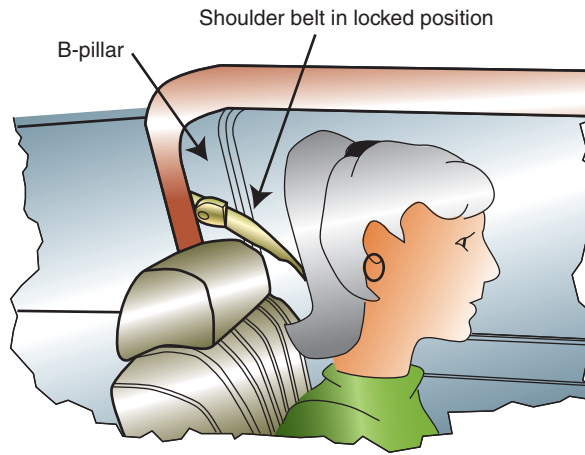
**FIGURE 15-2** Passive seatbelt restraint system uses a motor to put the shoulder harness around the occupant.



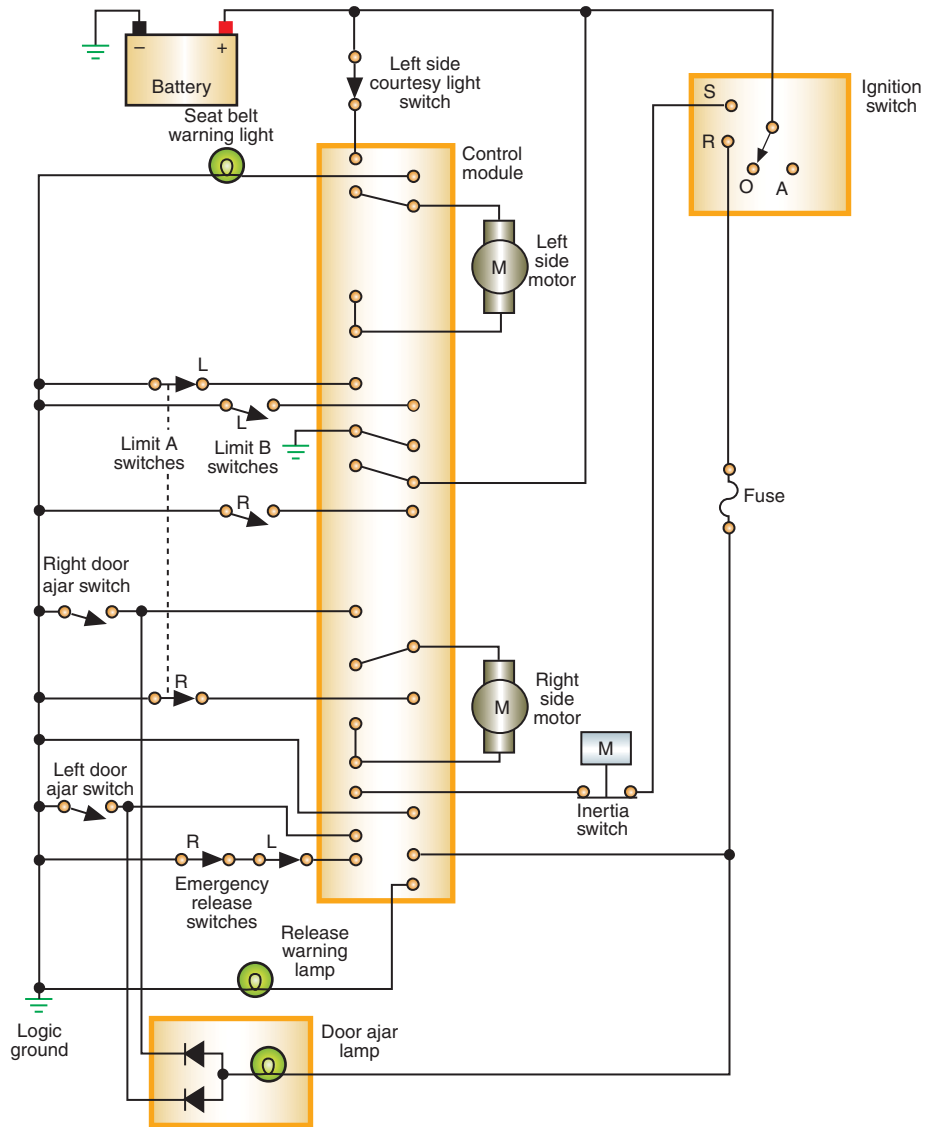
**FIGURE 15-3** Inertia lock seatbelt retractor.



**FIGURE 15-4** When the door is opened, the motor pulls the harness to the A pillar.



**FIGURE 15-5** When the door is closed and the ignition switch is in the RUN position, the motor draws the harness to its lock position.



**FIGURE 15-6** Typical circuit diagram of automatic seat belt system using a control module.

The door ajar switches signal the position of the door to the module. The switch is open when the door is closed. This signal is used by the control module to activate the motor and move the harness to the lock point behind the occupant's shoulders. If the module receives a signal that the door is open, regardless of ignition switch position, it will activate the motor to move the harness to the FORWARD position.

The limit switches inform the module of the position of the harness. When the harness is moved from the FORWARD position, the front limit switch (limit A) closes. When the harness is located in the LOCK position, the rear limit switch (limit B) opens and the module turns off the power to the motor. When the door is opened, the module reverses the power feed to the motor until the A switch is opened.

An emergency release mechanism is provided in the event that the system fails to operate. The normally closed emergency release switch is opened whenever the release lever is pulled. The module will turn on the warning lamp in the instrument panel and sound a chime to alert the driver. The opened switch also prevents the harness retractors from locking.

Ford incorporates the **fuel pump inertia switch** into the automatic seat belt system. The fuel pump inertia switch is a normally closed switch that will open if the vehicle is involved in an impact at speeds over 5 mph or if it rolls over. When the switch opens, it turns off power to the fuel pump. This is a safety feature to prevent fuel from being pumped onto the ground or hot engine components if the engine dies. The switch has to be manually reset if it is triggered (Figure 15-7). If the seat belt module receives a signal that the switch is open, it prevents the harness from moving to the forward position if the door opens.

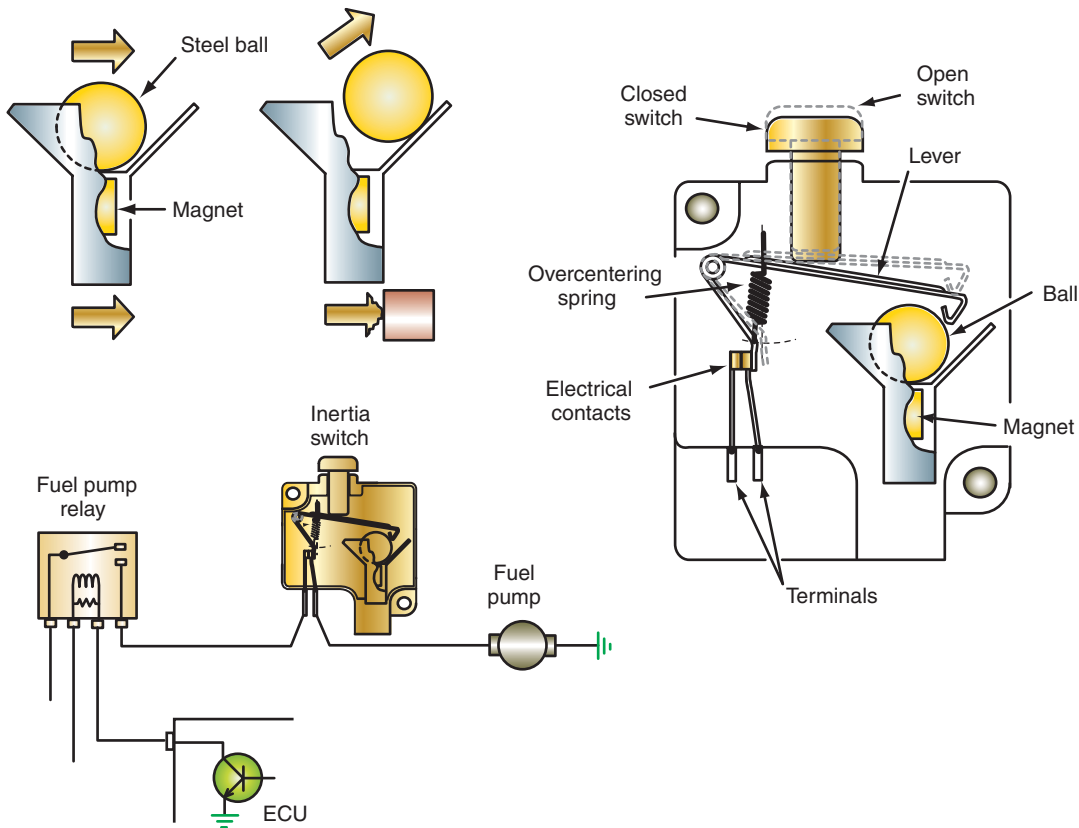
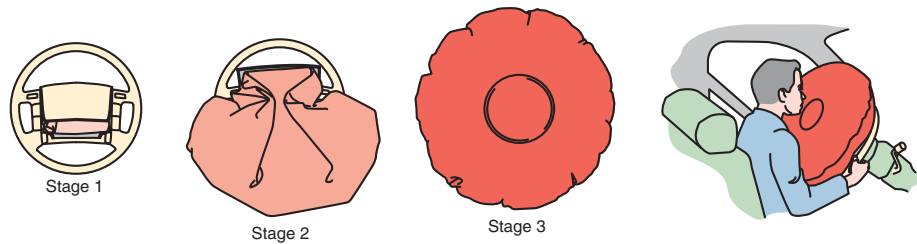


FIGURE 15-7 Fuel pump inertia switch.

© Delmar/Cengage Learning





**FIGURE 15-8** Air bag deployment sequence.

© Delmar/Cengage Learning

### Shop Manual

Chapter 15, pages  
644, 648



## A BIT OF HISTORY

Although there were several early attempts at developing air bags, it was not until the mid-1980s that many manufacturers made air bags available as an option. In 1988, Chrysler was the first automotive manufacturer to offer the driver-side air bag as standard equipment.

## AIR BAG SYSTEMS

The need to supplement the existing restraint system during frontal collisions has led to the development of the supplemental inflatable restraint (SIR) or air bag systems (Figure 15-8).

Today the most common name for the air bag system is supplemental restraint systems (SRS). The air bags are considered supplemental restraints because the seat belts must be worn at all times in order to provide maximum occupant protection. The air bag is a supplement and the seat belt is the primary restraint system. Seat belts must be worn in an air bag-equipped vehicle for the following reasons:

1. Seat belts hold the occupants in the proper position when the air bag inflates.
2. Seat belts reduce the risk of injury in less severe accidents in which the air bag does not deploy.
3. Seat belts reduce the risk of occupant ejection from the vehicle, thus reducing the possibility of injury.

The air bag system contains an inflatable air bag module that is designed into the steering wheel. Collapsible steering columns are used with the air bag system and tilt steering wheels are still optional. If the vehicle is involved in a frontal collision, the air bag inflates rapidly to keep the driver's body from flying ahead and hitting the steering wheel or windshield. The frontal impact must be within 30 degrees of the vehicle centerline to deploy the air bag. The air bag system helps to prevent head and chest injuries during a collision. The air bag system may be referred to as a passive restraint because it does not require active participation by the driver.

## Common Components

A typical air bag system consists of sensors, an occupant restraint controller, a clockspring, and an air bag module. See the typical location (Figure 15-9) of the common components of the SRS system.

**AUTHOR'S NOTE:** Many of the components used for driver-side air bags are similar to those used in passenger-side air bags. The basic operation of the two systems is the same.

### Shop Manual

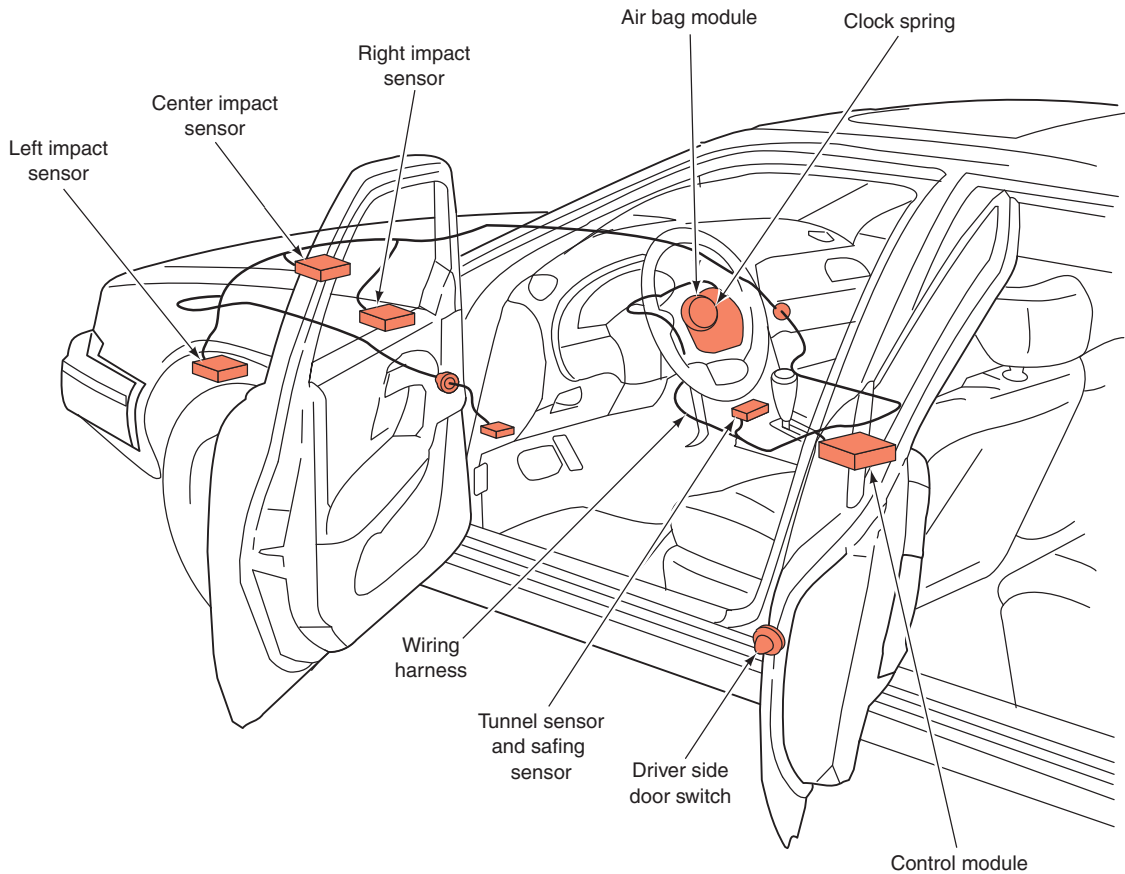
Chapter 15, page 651

The air bag is made of neoprene-coated nylon.

**Air Bag Module.** The air bag module contains the air bag and inflator assembly packaged into a single module. This module is mounted in the center of the steering wheel (Figure 15-10).

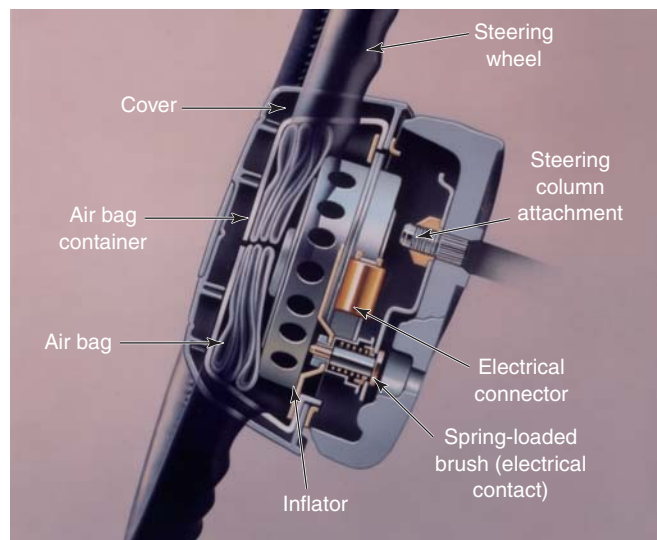
The purpose of the air bag module is to inflate the air bag in a few milliseconds when the vehicle is involved in a frontal collision. A typical fully inflated driver's-side air bag has a volume of 2.3 cu. ft. (65 L).





© Delmar/Cengage Learning

**FIGURE 15-9** Typical location of components of the air bag system.



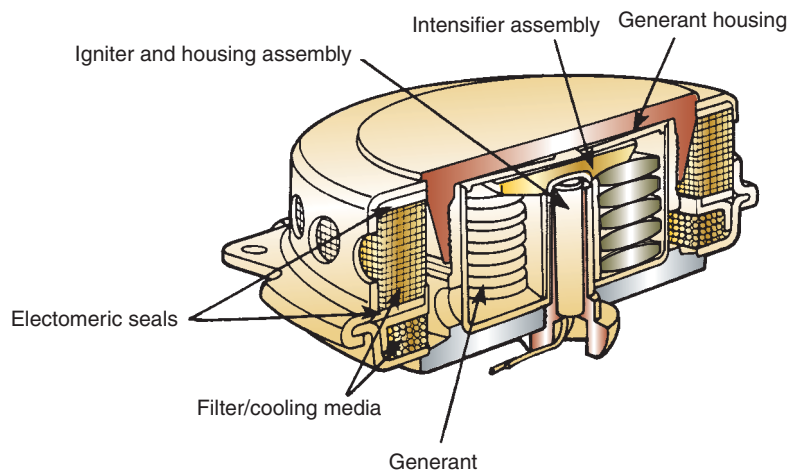
© Delmar/Cengage Learning

**FIGURE 15-10** Air bag module components.

The air bag module uses pyrotechnology (explosives) to inflate the air bag. The **igniter** is an integral component of the inflator assembly (Figure 15-11) because it starts a chemical reaction to inflate the air bag. The igniter is a combustible device that converts electric energy into thermal energy to ignite the inflator propellant.

At the center of the igniter assembly is the **squib**, which contains zirconic potassium percholate (ZPP). The squib is similar to a blasting cap. Squib is a pyrotechnic term used for a fire

The air bag module cannot be serviced. If it has been deployed, or is defective, it must be replaced.



© Delmar/Cengage Learning

**FIGURE 15-11** Igniter assembly.

cracker that burns but does not explode. The squib starts the process of air bag deployment. When as little as 400 ma is supplied through the squib, the air bag deploys.

Three components are required to create an explosion: fuel, oxygen, and heat. The squib and the igniter charge of barium potassium nitrate (a very fast-reacting explosive) provide the heat necessary for inflator module explosion. Fuel is supplied by the generant, which contains sodium azide and cupric oxide. The sodium azide provides hydrogen and the cupric oxide provides oxygen. When the chemicals in the inflator module explode, large quantities of hot, expanding nitrogen gas are produced very quickly. This expanding nitrogen gas flows through the igniter assembly diffuser, where it is filtered and cooled before inflating the air bag. Four layers of screen are positioned on each side of the ceramic in the filter. Sodium oxide dust is trapped by the filter. Sodium hydroxide is an irritating caustic. Therefore, automotive technicians are always warned to wear safety goggles and protective gloves when servicing deployed air bags. Within seconds after air bag deployment, the sodium hydroxide changes to sodium carbonate.

Tear seams in the steering wheel cover and in the instrument panel cover above the passenger's-side air bag split easily and allow the air bag to exit from the module. Large openings under the air bag, where it attaches to the module, allow the air bag to deflate in 1 second so it does not block the driver's view or cause a smothering condition.

Combustion temperature in the inflator module reaches about 2,500°F (1,371°C), but the air bag will remain slightly above room temperature. Typical by-products from inflator module combustion are:

1. Nitrogen—99.2%.
2. Water—0.6%.
3. Hydrogen—0.1%.
4. Sodium oxide—less than 1/10 of 1 part per million (ppm).
5. Sodium hydroxide—very minute quantity.

Many air bags pack corn starch into the inflator module. This, along with other combustion by-products, may appear as a white dust during and after air bag deployment.

Not all air bags systems use nitrogen gas to inflate the bag; some use compressed argon gas to inflate the air bag.

**Clockspring.** The clockspring conducts electrical signals to the module while allowing steering wheel rotation (Figure 15-12). The clockspring is a winding of special electric conductor tape housed in a plastic retainer. The clockspring maintains continuity between the



© Delmar/Cengage Learning

**FIGURE 15-12** The clock spring provides for electrical continuity in all steering wheel positions.

air bar (and any steering wheel–mounted switches) and body wiring harness as the steering wheel is rotated. The clockspring is located between the column and the steering wheel. The clockspring electrical connector contains a long conductive ribbon. The wires from the air bag electrical system are connected through the underside of the clockspring electrical connector to one end of the conductive ribbon. The other end of the conductive ribbon is connected through wires on the top side of the clockspring electrical connector to the air bag module. When the steering wheel is rotated, the conductive ribbon winds and unwinds, allowing steering wheel rotation while completing electrical contact between the system and the air bag module.

**Occupant Restraint Controller (ORC).** The air bag control module, called the occupant restraint controller (ORC), constantly monitors the readiness of the air SRS electrical system. If the ORC determines that there is a fault in the system, it will illuminate the indicator light and store a diagnostic trouble code. Depending on the fault, the SRS system may be disarmed until the fault is repaired.

The ORC also supplies backup power to the air bag module in the event the battery or cables are damaged during an accident. The stored charge can last for up to 30 minutes after the battery is disconnected.

It is important for the technician to understand that not all SRS system ORCs are capable of turning off the system in the event of a fault. A typical ORC performs the following functions:

1. Controls the instrument panel warning lamp.
2. Continuously monitors all air bag system components.
3. Controls air bag system diagnostic functions.
4. Provides an energy reserve to deploy the air bag if battery voltage is lost during a collision.

On some systems, the ORC is responsible for deploying the air bag when appropriate signals are received from the sensors. These systems may be able to turn off the air bags if a fault is detected.

Most air bag sensors contain a resistor connected in parallel with the sensor contacts. When the ignition switch is in the RUN position, the ORC supplies a small amount of current through these resistors to monitor the system. If a short, ground, or open circuit occurs in the wiring or sensors, the current flow changes. When the ORC senses this condition, it illuminates the air bag warning light in the instrument panel.

The clockspring is also known as the coil assembly, the cable reel assembly, the coil spring unit, and the contact reel.

#### Shop Manual

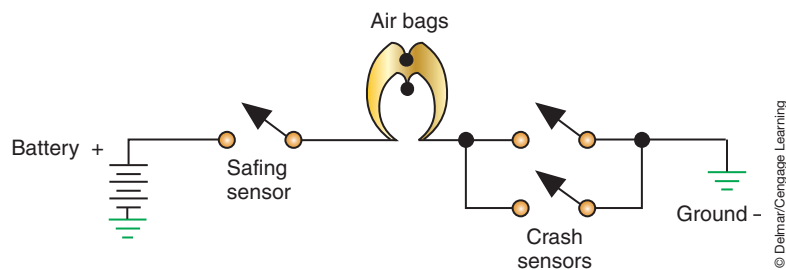
Chapter 15, page 648

The ORC is also called the air bag control module (ACM).

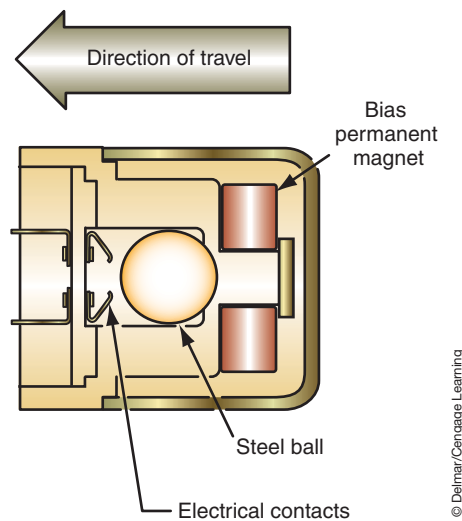
**Sensors.** To prevent accidental deployment of the air bag, most systems require that at least two sensor switches be closed to deploy the air bag (Figure 15-13). The number of sensors used depends on the system design. Some systems use only a single sensor and others use up to five. The name used to identify the different sensors also varies among manufacturers.

On most three-sensor systems, the **crash sensors** are usually located in the engine compartment or below the headlights. Crash sensors are normally open electrical switches designed to close when subjected to a predetermined impact. A single **safing sensor** is usually located inside the ORC, which in turn is mounted on the centerline of the vehicle in the passenger compartment. The safing sensor determines if the collision is severe enough to inflate the air bag. When one of the crash sensors and the safing sensor closes, the electrical circuit to the igniter is complete. The igniter starts the chemical chain reaction that produces heat. The heat causes the generant to produce nitrogen gas, which fills the air bag.

There are several different types of sensors used. Common sensors include mass-type, roller-type, and accelerometers. The mass-type sensor contains a normally open set of gold-plated switch contacts and a gold-plated ball that acts as a sensing mass (Figure 15-14). The gold-plated ball is mounted in a cylinder coated with stainless steel. A magnet holds the ball about 1/8 inch (3.2 mm) away from the contacts. When the vehicle is involved in a frontal



**FIGURE 15-13** Typical sensor wiring circuit diagram.



**FIGURE 15-14** Some crash sensors hold the sensing mass by magnetic force. If the impact is severe enough to break the ball free, it will travel forward and close the electrical contacts.

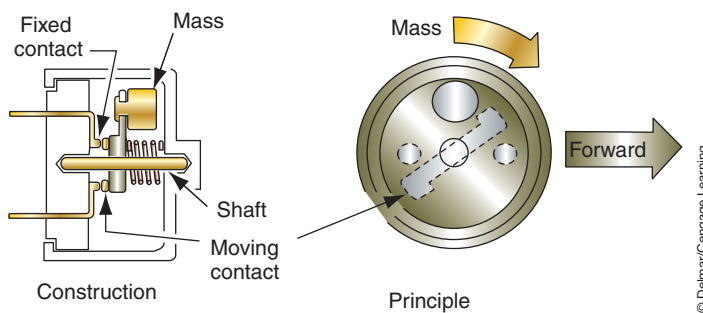
collision of sufficient force, the sensing mass (ball) moves forward in the sensor and closes the switch contacts.

For proper operation, sensors must be mounted with the forward marking on the sensor facing toward the front of the vehicle and in the original position designed by the manufacturer. Sensor brackets must not be bent or distorted.

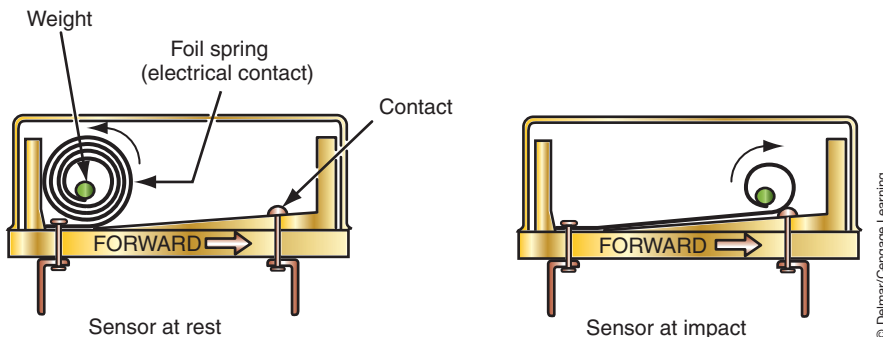
Some mass-type air bag sensors contain a pivoted weight connected to a moving contact. When the vehicle is involved in a frontal collision with sufficient impact to deploy the air bag, the sensor weight moves in a circular path until the moving contact touches a fixed contact (Figure 15-15).

The roller-type sensor has a roller mass mounted on a ramp (Figure 15-16). One sensor terminal is connected to the ramp. The second sensor terminal is connected to a spring contact extending through an opening in the ramp without contacting the ramp. A 10,000-Ω resistor is connected in parallel to the sensor contacts. The roller is held against a stop by small retractable springs on each side. These springs are similar to a retractable tape measure. If the vehicle is involved in a frontal collision at a high enough deceleration rate to deploy the air bag, the roller moves up the ramp and strikes the spring contact. In this position, the roller completes the circuit between the ramp and the spring contact.

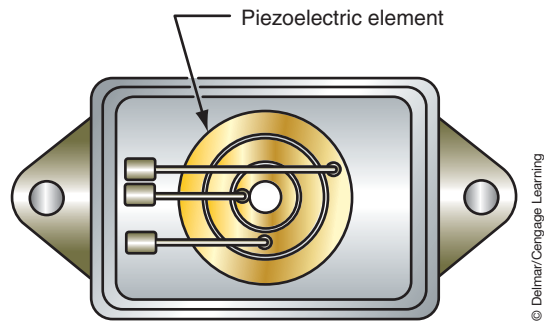
In many air bag systems, **accelerometers** are used to sense deceleration forces. An accelerometer generates an analog voltage in relation to the severity of deceleration forces. The accelerometer also senses the direction of impact force. The accelerometer contains a piezoelectric element that is distorted during a collision. This element generates an analog voltage in relation to the impact force (Figure 15-17). Usually, the accelerometer-type sensor is inside the air bag computer. The analog voltage from the piezoelectric element is sent to a collision-judging circuit in the air bag computer. The accelerometer is capable of determining the direction and severity of impact. If the collision impact is great enough, the computer deploys the air bag.



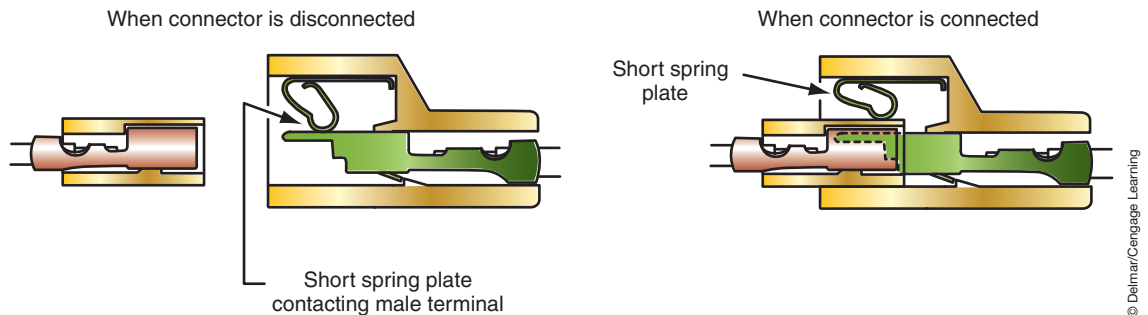
**FIGURE 15-15** Mass-type air bag sensor with pivoted weight connected to a moving contact.



**FIGURE 15-16** Roller-type air bag sensor.



**FIGURE 15-17** Accelerometer air bag sensor with piezoelectric element.



**FIGURE 15-18** Shorting bars on air bag system wiring connectors.

Air bag systems do not deploy the air bag based on vehicle speed information. Most systems do not even have vehicle speed input. The sensors close or provide an electrical signal based on the rate of deceleration. Most systems require about 30 g of force before the air bag will be deployed.

**Shorting Bars.** The SRS electrical system is a dedicated system that is not interconnected with other electrical systems on the vehicle. All wiring harness connectors in the system are the same color for easy identification. Shorting bars are located in some of the component wiring harness connectors in the air bag system, such as the inflator module connector at the steering column base. The shorting bars connect terminals together when the wiring connectors are disconnected (Figure 15-18). Since the terminals are shorted, there is no way to have electrical potential, which prevents accidental air bag deployment. If the ORC connector is disconnected, the shorting bars in the connector illuminate the air bag light.

## AIR BAG DEPLOYMENT

The sequence of events occurring during an impact of a vehicle traveling at 30 mph (48 kmh) is as follows:

1. When an accident occurs, the arming sensor is the first to close. It will close due to sudden deceleration caused by braking or immediately upon impact. One of the crash sensors will then close. The amount of time required to close the switches is within 15 milliseconds.
2. Within 40 milliseconds, the igniter module burns the propellant and generates the gas to completely fill the air bag.
3. Within 100 milliseconds, the driver's body has stopped forward movement and the air bag starts to deflate. The air bag deflates by venting the nitrogen gas through holes in the back of the bag.
4. Within 2 seconds, the air bag is completely deflated.



## AIR BAG WARNING LAMP

The air bag system warning lamp indicates the system condition to the driver. The warning lamp is operated by the ORC. Ignition on and crank signals are received by the ORC. When the ignition switch is placed in the RUN position, the air bag warning lamp should illuminate for a bulb check. In some systems, the lamp will flash seven to nine times and then remain steadily illuminated while the engine is cranking. Once the engine starts, the air bag warning lamp should be extinguished. An air bag system failure may be indicated by any of the following warning lamp conditions:

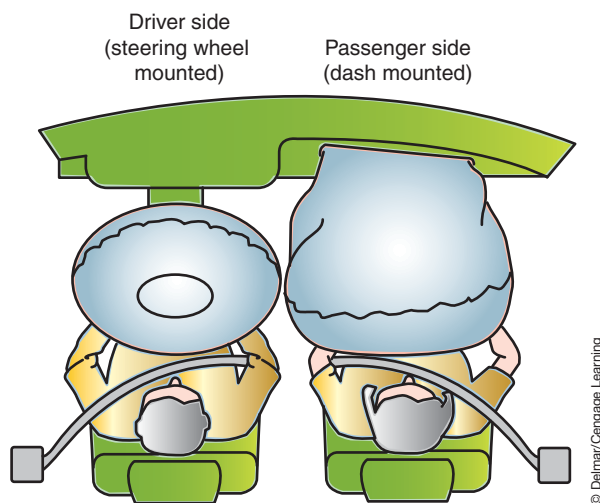
1. If the lamp remains on but does not flash when the ignition is turned on.
2. If the lamp flashes seven to nine times and then remains on when the ignition is turned on.
3. If the lamp comes on when the engine is running.
4. If the lamp does not come on at any time.
5. If the lamp does not come on steadily while the engine is cranking.

If any of these lamp conditions are present, the driver should have the air bag system checked.

## PASSENGER-SIDE AIR BAGS

Federal law expanded to require that all passenger vehicles produced after 1995 be equipped with front passenger-side air bags (Figure 15-19). Since there is a greater distance between the passenger and the instrument panel compared to the distance between the driver and the steering wheel, the passenger-side air bag is much larger. A typical passenger-side air bag has a fully inflated volume of 7 cubic feet (198 L). In most systems, the passenger-side air bag deploys with the driver-side air bag.

**AUTHOR'S NOTE:** Reference here to passenger-side air bags means the front-seat passenger air bag that is deployed from the instrument panel. This system is not to be confused with side-impact air bags, which will be discussed later.



**FIGURE 15-19** All vehicles manufactured after 1995 must have driver and front seat passenger side air bags.

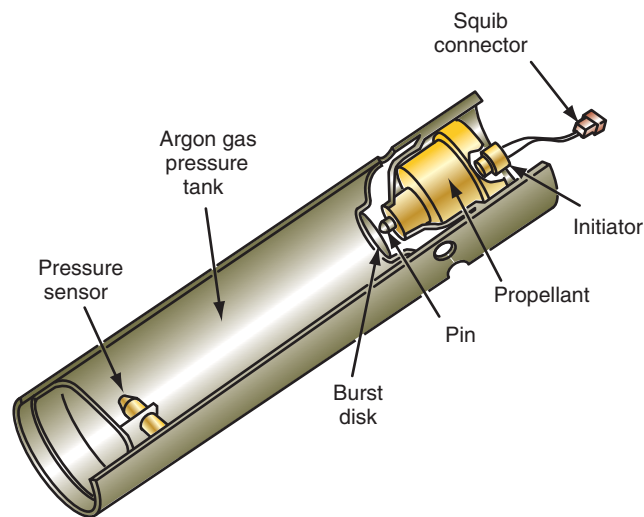


## HYBRID AIR BAG TYPES

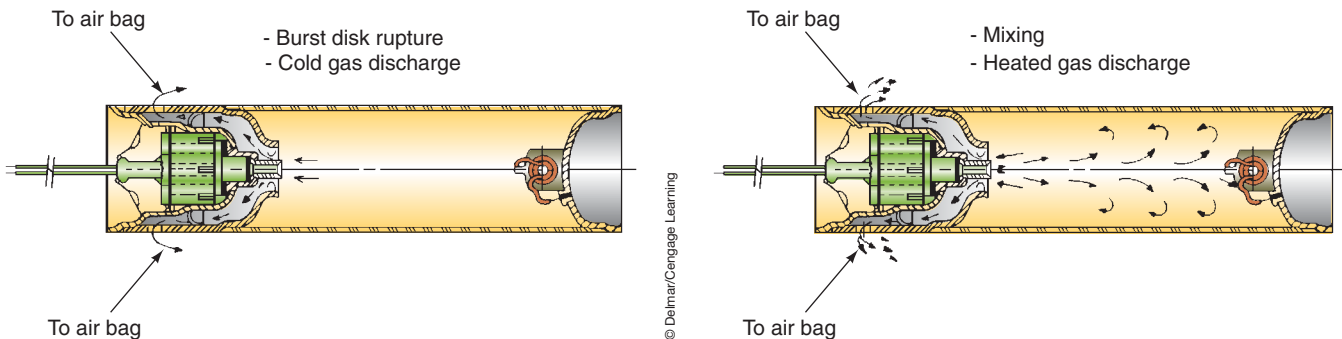
Up to this point, the discussion of air bags has centered around the conventional sodium azide type. However, there are **hybrid air bag** systems that use compressed gas to fill the air bag. There are three common types of hybrid air bag modules.

### Solid Fuel with Argon Gas

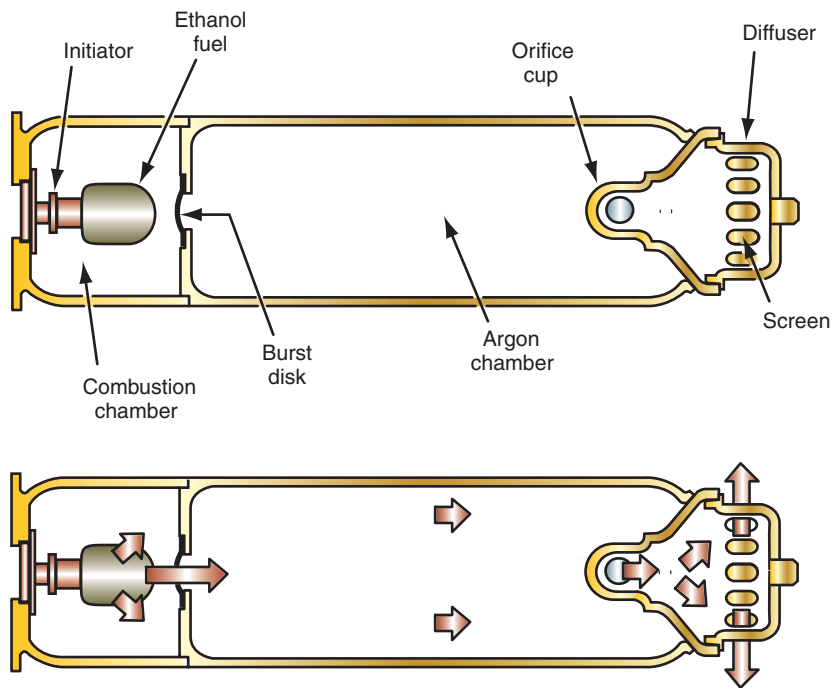
The first use of solid-fuel hybrid air bags was on the passenger-side air bags. They are now used for driver- and passenger-side air bags. The hybrid inflator module contains an initiator similar to the squib in other inflator modules. However, the hybrid inflator module also has a container of pressurized argon gas (Figure 15-20). The same method is used to energize the initiator in the hybrid inflator as in conventional systems. When the initiator is energized, the propellant surrounding the initiator explodes and pushes out the burst disc. As the pressurized argon escapes through the exhaust holes and fills the air bag, the burning propellant heats the argon gas (Figure 15-21). Heating of the gas makes it expand quickly to fill the air bag.



**FIGURE 15-20** Hybrid inflator module with argon gas pressure chamber.



**FIGURE 15-21** When the initiator is energized, the propellant explodes and punctures the container and allows pressurized argon gas to fill the air bag.



**FIGURE 15-22** Liquid-fueled hybrid inflator operation.

The early version of the hybrid system used a pressure sensor mounted in the end of the argon gas chamber opposite from the initiator and propellant. This sensor sends a signal to the ORC in relation to the argon gas pressure. If the gas pressure decreases below a preset value, the module illuminates the air bag warning light.

## Liquid Fuel with Argon Gas

The liquid-fueled air bag module uses a small quantity of ethanol alcohol to blow out the burst disc (Figure 15-22). Although similar to the hybrid system previously discussed, there are some differences in methods. In this system, the fuel blows the burst disc and, as the fuel continues to burn, the heat expands the argon gas. The expanding gas pushes through an orifice cup, over the diffuser, and into the air bag.

Alcohol is used because it ignites at a lower temperature and does not leave a harmful residue.

## Heated Gas Inflator

The heated gas inflator (HGI) is pressurized with a combustible mixture of 12% hydrogen gas and air. The mixture is ignited with a pyrotechnic squib.

## MULTISTAGE AIR BAG DEPLOYMENT

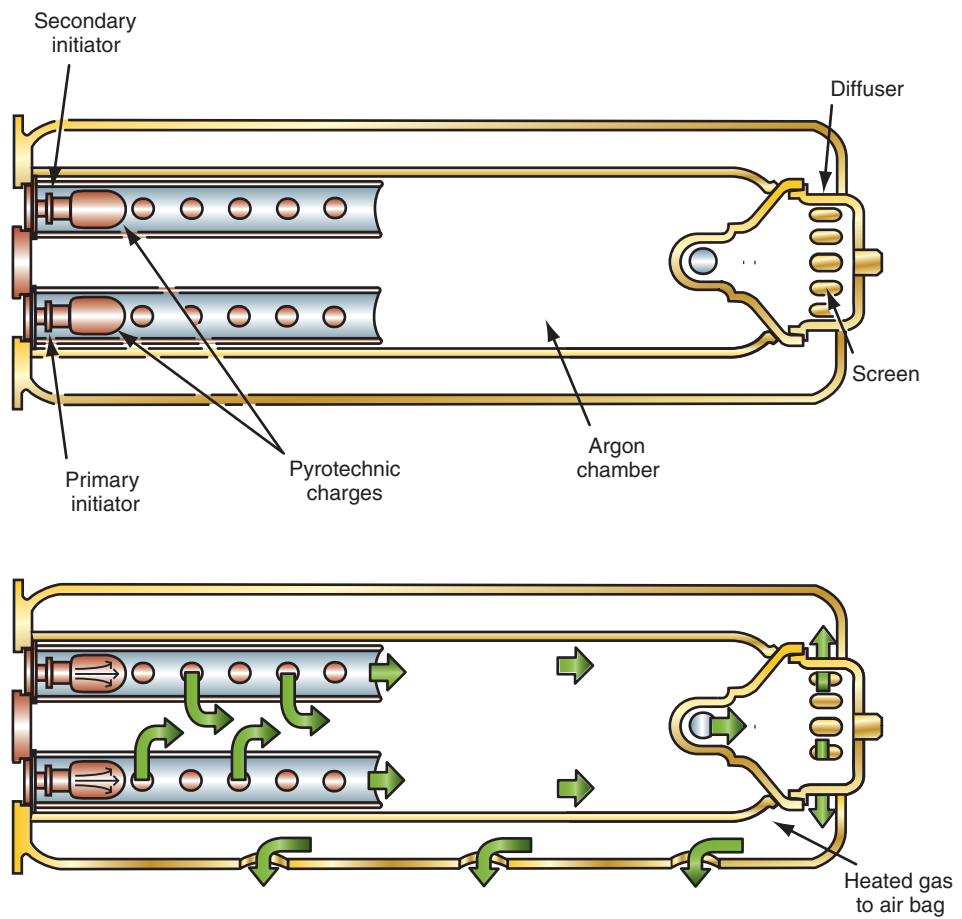
One recent development to the air bag system is the development of **multistage air bags**. Multistage air bags are hybrid air bags that use two squibs to control the rate of inflation. Multistage air bags are used for both driver- and passenger-side air bags. These modules apply the principle of using heat to expand the argon gas to fill the air bag. The bag fills faster as the heat increases.

The air bag module of the multistage system uses two squibs (Figure 15-23). When one of the squibs is fired, the air bag will begin to deploy. The second squib is then fired to generate more heat so the air bag fills faster (Figure 15-24). The length of time between the firing of the two squibs determines the rate of air bag deployment. In a minor accident that requires air bag deployment at a slow rate, only the first squib is ignited. The second squib may be ignited 160 ms later to use up the other igniter charge but this is too late to fill the air bag. As the



© Delmar/Cengage Learning

**FIGURE 15-23** The multistage air bag module uses two squibs.



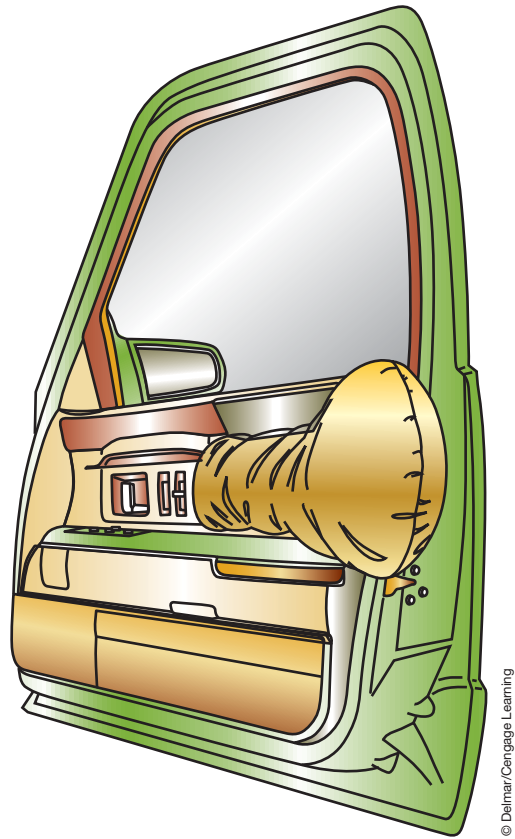
© Delmar/Cengage Learning

**FIGURE 15-24** Sequence of events within the multistage inflator.

severity of the deceleration forces indicate faster air bag deployment is needed, the firing of the squibs will get closer together.

## SIDE-IMPACT AIR BAGS

Many manufacturers are now offering side-impact air bag systems. Most of these are a singlestage hybrid design. The location of the air bag varies depending on the vehicle. Some are designed to come out of the door panel (Figure 15-25), from the seat back

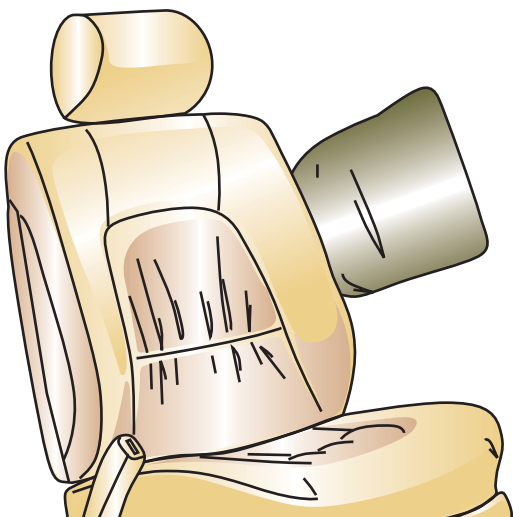


© Delmar/Cengage Learning

**FIGURE 15-25** Side impact air bag located in the door panel.

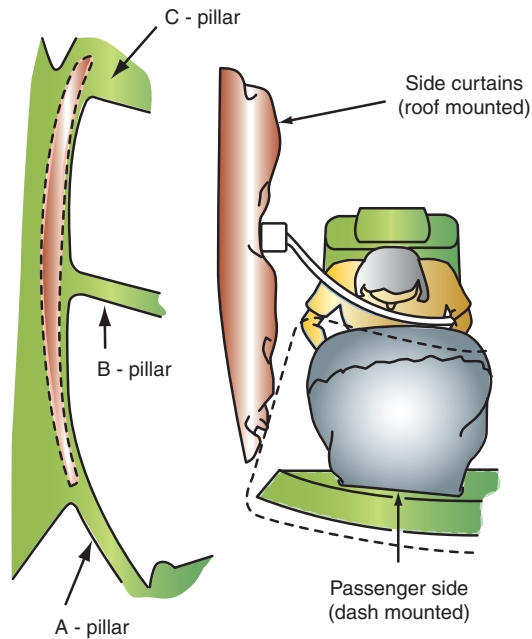
(Figure 15-26), between the A-pillar and the headliner (Figure 15-27), or from a roof-mounted curtain in the headliner that protects both the front- and rear-seat occupants (Figure 15-28).

The side-impact air bags deploy separately from the front air bags. The system may have a separate control module mounted in the B-pillars of the vehicle or sensors that relay impact information to the ORC. The ORC then deploys the side air bags.



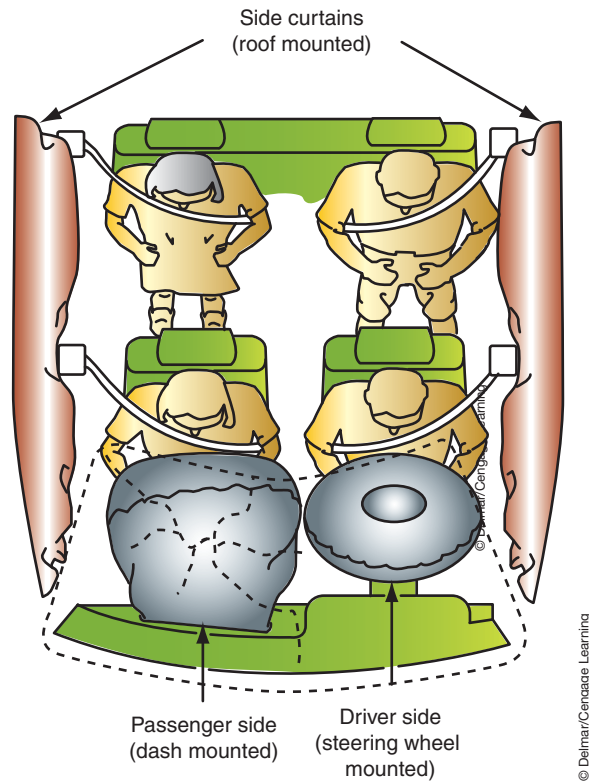
© Delmar/Cengage Learning

**FIGURE 15-26** Side impact air bag located in the seat back cushion.



© Delmar/Cengage Learning

**FIGURE 15-27** Side impact air bag designed to protect the occupant's head from injury.



**FIGURE 15-28** Side impact air-curtains protect both front and rear seat occupants.

## AIR BAG ON/OFF SWITCHES

For the air bags to perform safely, there should be at least 10 inches (25 cm) between the air bag module and the occupant. Also, children should not sit in the front seat with an air bag, and a rearward-facing infant seat should *NEVER* be used in the front seat with an air bag. Some vehicles with limited rear seating may be factory equipped to turn off the passenger air bag if it would not be safe to have it deploy. One such type of automatic system is used by Mercedes (Figure 15-29). This system uses a resonator built into the child seat to recognize the seat is in place. A light on the dash will confirm that the passenger-side air bag is turned off.



**FIGURE 15-29** The BabySmart<sup>®</sup> system used by Mercedes automatically deactivates the passenger side air bag when a child safety seat is placed in the front seat.

Most systems rely on input from the driver or passenger to turn a switch (Figure 15-30). Early systems placed a resistor in the passenger-side air bag circuit when the switch was turned to the off position (Figure 15-31). Turning the switch opens the circuit between the ORC and the passenger-side air bag so it will not deploy. The resistor is used to trick the ORC into believing the circuit is still intact so it will not set false fault codes.

Newer systems use a MUX signal from an on/off module (Figure 15-32). The occupant restraint controller (ORC) provides a pulsed signal to the on/off module at a frequency



FIGURE 15-30 Passenger side air bag ON/OFF switch.

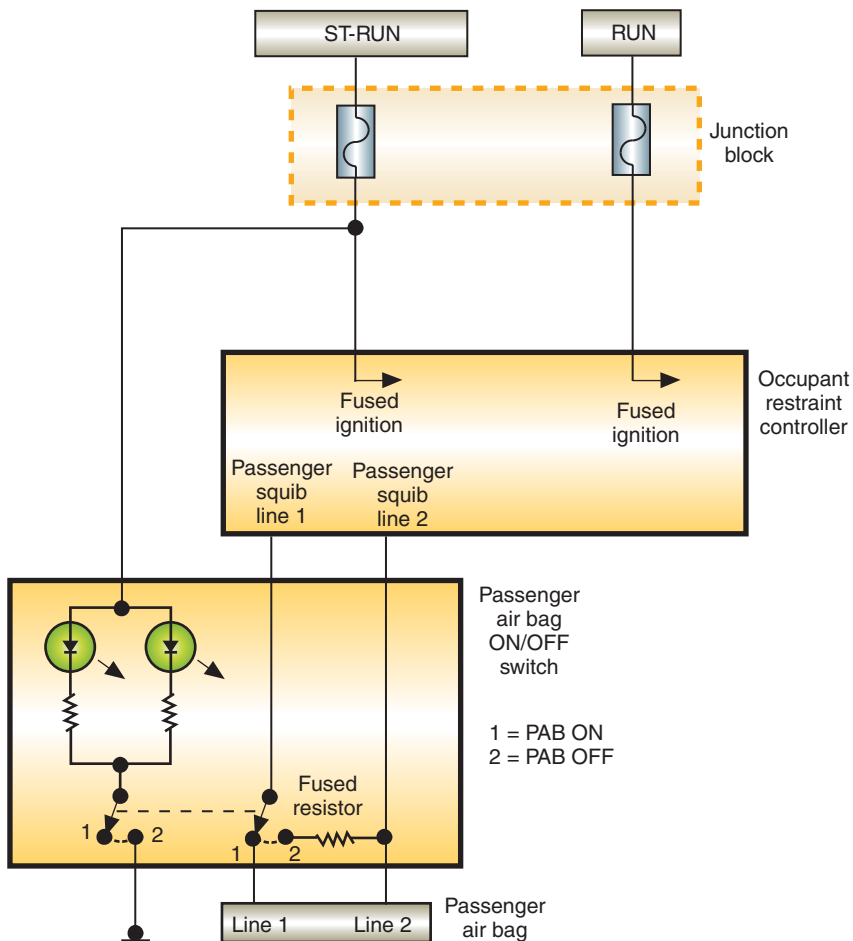
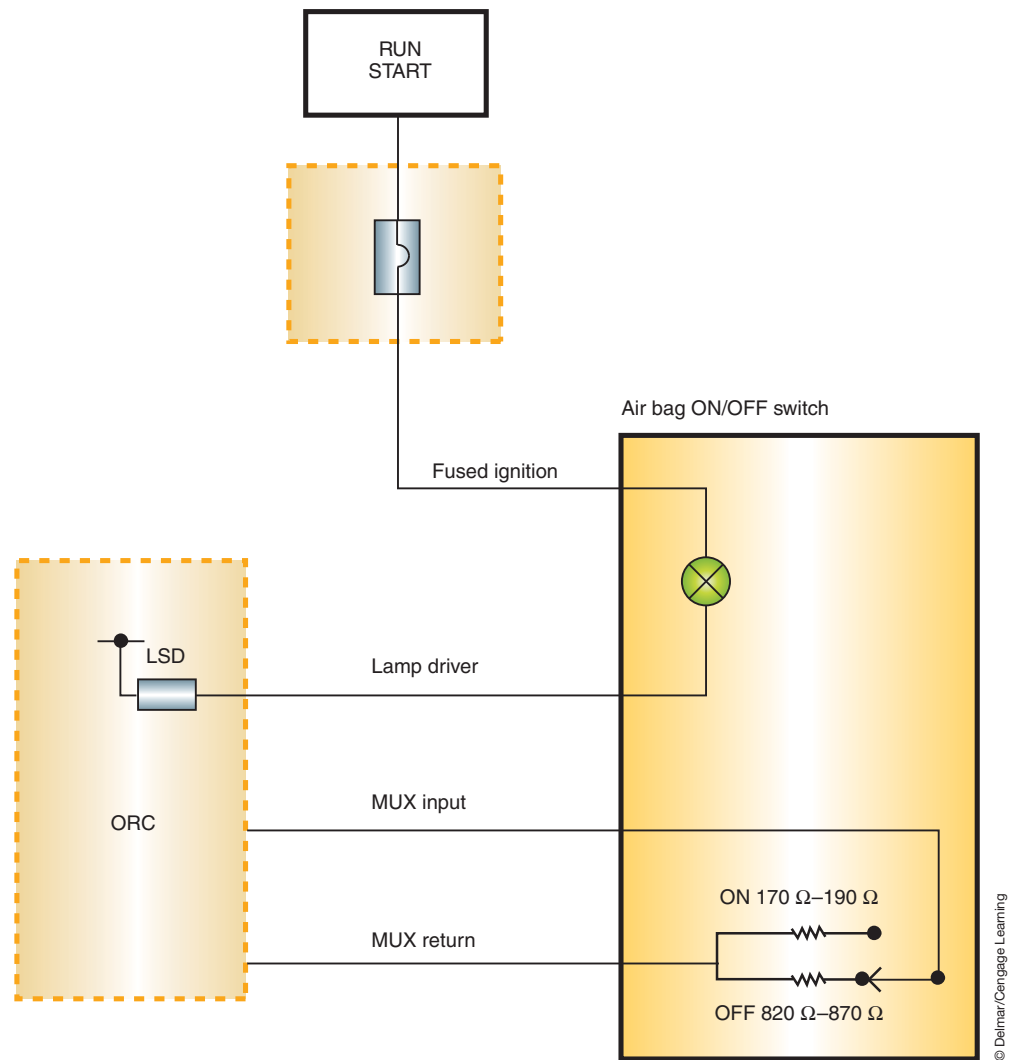


FIGURE 15-31 Wiring diagram of a hardwired passenger side air bag ON/OFF switch.





**FIGURE 15-32** Wiring diagram of MUX circuit for passenger side air bag ON/OFF switch.

of 10 Hz with a 3% duty cycle. The ORC monitors the voltage drop across the switch. If the switch is in the ON position, 4 volts will be monitored. In the OFF position, about 10 volts will be monitored. A reading of 20 volts will be considered an open, while a reading of zero volts would set a short-circuit fault. If the switch is in the OFF position, the ORC will deactivate the passenger air bag internally. This system does not interrupt the circuit as earlier systems did.

## Deactivation and Retrofit On/Off Switches

Some owners may desire to have their air bag systems deactivated or to have a switch installed that will allow them to deactivate the system as needed. At this time, in order to perform this service, the vehicle owner must first obtain permission from the National Highway Traffic Safety Administration (NHTSA). Permission may be obtained to turn off one or both of the front air bags. The vehicle owner must supply a letter of approval before the deactivation or switch kit is installed. Deactivation may be approved due to medical reasons, size of the driver (not able to sit at least 10 inches [25 cm] from the air bag), or because a child must sit in the front seat.

The customer must also sign a waiver form written on the shop's letterhead. This form releases the shop owner and technician from any liability that may occur as a result of the air bag systems being turned off. The waiver also gives the technician permission to put the required warning labels on the vehicle.



## SEAT BELT PRETENSIONERS

To assure that the driver and/or passenger stay in position during an accident, some vehicles are equipped with seat belt **pretensioners**. There are two ways of mounting the pretensioner.

The first is to mount the pretensioner on the buckle side of the seat belt (Figure 15-33). At the same time the front air bags are deployed, the control module will also deploy the pretensioner. A small piston is attached to a cable connected to the buckle. There is a charge below the piston. When the pretensioner is fired, the piston will travel up the cylinder, pulling the buckle tight by the cable.

The pretensioner can also be mounted on the retractor side of the seat belt (Figure 15-34). The system type shown has a retractor assembly with a fan wheel–type unit attached to one end (Figure 15-35). When the pretensioner is fired, a series of balls shoot out of the channel and hit the fan wheel. As the balls hit the fan wheel, the retractor rotates and pulls the seat belt tight. The last ball is a little bigger than the others and will lodge into the fan wheel, causing the seat belt to lock.

**Pretensioners** are used to tighten the seat belt and shoulder harness around the occupant during an accident severe enough to deploy the air bag. Pretensioners can be used on all seat belt assemblies in the vehicle.



**FIGURE 15-33** Buckle-mounted pretensioner.



**FIGURE 15-34** Buckle-mounted pretensioner.



**FIGURE 15-35** The balls are shot at the fan wheel, which causes the retractor to wind up the seatbelt tight against the occupant.



© Delmar/Cengage Learning

**FIGURE 15-36** Inflatable knee blocker.

## INFLATABLE KNEE BLOCKERS

Manufacturers are now incorporating a driver's-side **inflatable knee blocker (IKB)** into their air bag systems (Figure 15-36). The IKB is located on the driver's side of the vehicle beneath the instrument panel cover and is attached to the instrument panel reinforcement. The IKB deploys simultaneously with the driver's-side air bag to increase driver impact protection. The IKB provides upper-leg protection and positioning of the driver. When the IKB is deployed, it pushes a tethered plate against the driver's knees. This keeps the driver in the correct upright position during a collision, so the air bag is more efficient.

## OCCUPANT CLASSIFICATION SYSTEMS

As the result of an amendment to the Federal Motor Vehicle Safety Standard 208, manufacturers are presently designing and installing air bag systems that reduce the risk of injuries resulting from air bag deployment. The goal of this amendment is to reduce injuries suffered by children and small adults that are in the **fifth percentile female** weight classification. The fifth percentile female is classified to be those who weigh less than 100 pounds (45 kg). The amendment mandates that the passenger-side air bag be suppressed when an infant in a rear-facing infant seat (RFIS) occupies the front passenger seat. The amendment also mandated that a passenger air bag disable lamp (PADL) be illuminated whenever the passenger seat is occupied and the passenger-side air bag has been suppressed (Figure 15-37). If the front passenger seat is not occupied, the lamp is not illuminated.

**AUTHOR'S NOTE:** The fifth percentile female is determined by averaging all potential occupants by size and then plotting the results on a graph. The middle of the bell curve on the graph would indicate the majority of occupants. At the far right of the bell curve would be those occupants who are very large, while on the left side of the curve would be occupants that are very small. At the fifth percentile range on the left of the curve, the majority of occupants would be female.

To meet these new requirements, manufacturers have taken different approaches. In this section, the Delphi and TRW systems are presented to provide two different methods



© Delmar/Cengage Learning

**FIGURE 15-37** The PADL illuminates if the air bag is suppressed.

of meeting this regulation. The Delphi system uses a bladder to determine weight, and the TRW system uses strain gauges. Both systems use an occupant classification module (OCM) that determines the weight classification of the front passenger and sends this information to the ORC. Also, both system use multistage passenger-side air bags.

## Delphi Bladder System

The bladder system uses a silicone-filled bladder that is positioned between the seat foam and the seat support (Figure 15-38). A pressure sensor is connected by a hose to the bladder (Figure 15-39). The three-wire pressure sensor operates similar to the way an MAP sensor operates. When the seat is occupied, pressure that is applied to the bladder disperses the silicone and the pressure sensor reads the increase in pressure. The pressure reading is inputted to the ORC (Figure 15-40).

Since pressure is used to determine seat occupation and ultimately occupant classification, the system will correct for changes in atmospheric pressures. In addition, natural aging of the seat foam is also learned by monitoring gradual changes. The OCM stores seat aging and calibration information in the ORC. If a new OCM is installed, it will retrieve this information from the ORC so the system will continue to function properly.

When the seat is not occupied, the OCM compares the sensor voltage with the value stored in memory. The voltage values measures by the sensor will change as weight is added to the seat. Based on the change of voltage from the sensor, the OCM can determine the weight of the occupant.

**Shop Manual**  
Chapter 15, page  
656



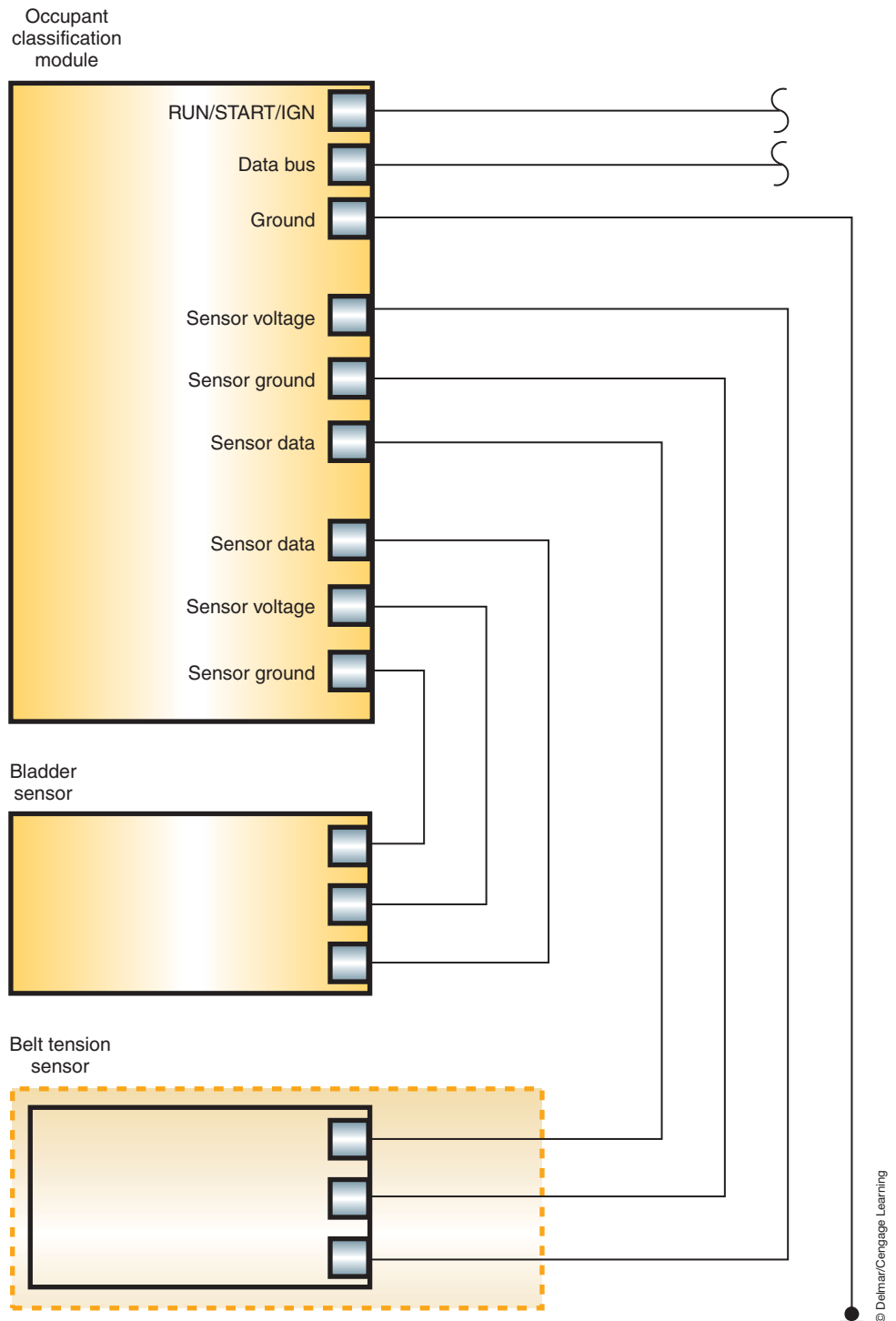
© Delmar/Cengage Learning

**FIGURE 15-38** Bladder used to determine occupant classification.



© Delmar/Cengage Learning

**FIGURE 15-39** The pressure sensor changes voltage signals as weight is added to the bladder.



**FIGURE 15-40** Schematic of bladder occupant classification system.

Based on the weight information that the OCM sends to the ORC, the following is determined:

- An empty seat. The PADL is off and the air bag is suppressed.
- Weight equivalent to or less than that of a six-year-old child. The PADL is illuminated and the air bag is suppressed.
- Weight equivalent to or greater than that of a fifth percentile female. The PADL light is off and the front passenger air bag is enabled. Deployment rate is based on the severity of the impact.





© Delmar/Cengage Learning

**FIGURE 15-41** Belt tension sensor.

Since an infant seat that is securely strapped into the seat will cause an increase of downward pressures on the bladder, the system uses a **belt tension sensor (BTS)**. The BTS is a strain gauge–type sensor located on the seat belt anchor (Figure 15-41). The increase in pressures can be great enough to indicate a weight greater than that of a fifth percentile female is in the seat. In this case the air bag will not be suppressed. However, the BTS will indicate that the belt is tight around an object (about 24–26 lbs. [11–12 kg] of force). The reading will indicate that the belt is tighter than what it normally would be for a belt around a person.

As seat belt tension is increased, the sensor voltage changes. Based on the change of voltage from the BTS, the OCM can estimate how much of the sensed load results from the cinched seat belt. If the BTS indicates a cinched seat belt load over a certain threshold, the OCM determines a rear-facing infant classification.

## TRW Strain Gauge System

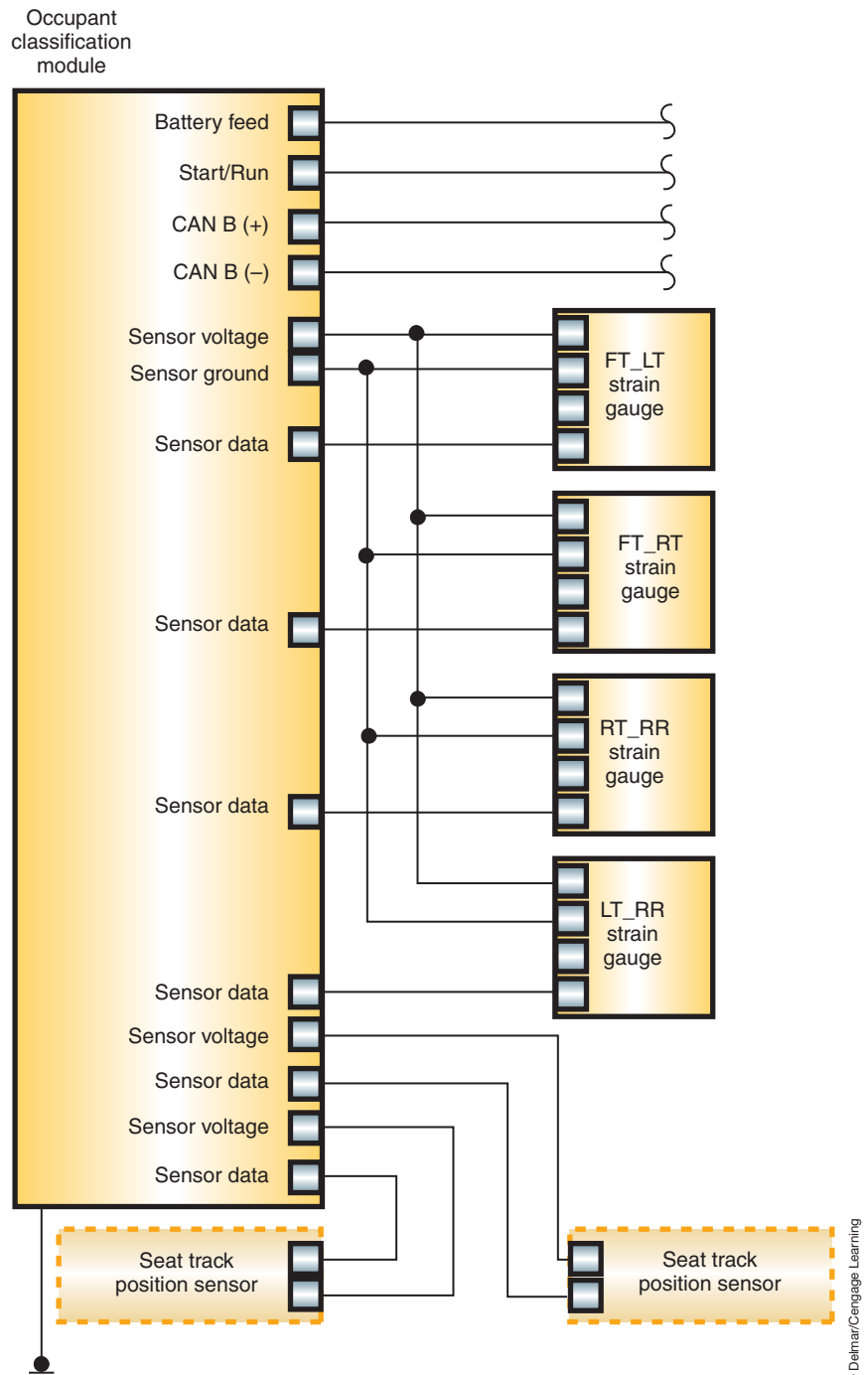
The TRW system uses four strain gauges to determine weight classification (Figure 15-42). One strain gauge is located at each corner of the seat frame where the frame attaches to the seat riser. The strain gauges support the weight of the seat. Data from each sensor is sent to the OCM (Figure 15-43).

The OCM compares current voltage readings with the values stored in memory. The electrical resistance of the strain gauge changes based on the amount of strain against it. A circuit board is bonded to the frame of the gauge. The circuit board has a grid made of metallic foil that changes in resistance when strain is applied. As weight is added to the seat, the voltage values of the sensors change. Based on the change of voltage from each sensor, the OCM can determine the occupant's weight. The OCM will attempt to calibrate every key off if the seat is not occupied.



© Delmar/Cengage Learning

**FIGURE 15-42** Strain gauge.



**FIGURE 15-43** Schematic of strain gauge occupant classification system.

Based on the weight information that the OCM sends to the ORC, the following is determined:

- An empty seat. The PADL is off and the air bag is suppressed.
- Weight equivalent to or less than that of a RFIS. The PADL is illuminated and the air bag is suppressed.
- Weight equivalent to a child. The PADL is off and the air bag is enabled. Deployment is at the low-risk deployment level.
- Weight equivalent to or greater than that of a fifth percentile female. The PADL is off and the front passenger air bag is enabled. Deployment rate is based on the severity of the impact.

The TRW system also utilizes a **seat track position sensor (STPS)** on both the driver and passenger seats. The STPS provides information to the OCM concerning the position of the seat in relation to the air bag. The OCM sends this information over the data bus to the ORC. The ORC modifies the deployment strategy based on this information. If the occupant's seat position is closer to the air bag, the deployment rate of the air bag will be slower than for an occupant's seat that is position farther away from the air bag.

The STPS uses a Hall-type sensor. The STPS is mounted onto a seat rail while a steel plate is mounted to the seat track. As the seat is moved, the steel plate covers or uncovers the sensor's magnetic field. This alters the current flow in the sensor.

**AUTHOR'S NOTE: Beginning in the 2006 model year, the use of classification systems was being reduced due to new technologies in air bag systems that will protect an infant in the front seat as well as an adult driver. With the new technology air bags, the system is never suppressed and the air bag will deploy anytime the system determines sufficient g-forces. However, the air bag will not deploy at a rate that would injure a properly restrained infant or adult.**

## SUMMARY

---

- Passive restraints operate automatically with no action required on the part of the driver or occupant.
- The automatic seat belt system uses a control module to monitor operation by receiving inputs from door ajar switches, limit switches, and the emergency release switch.
- The air bag is a supplemental restraint. The seat belt is the primary restraint system.
- The air bag module is composed of the air bag and inflator assembly. It is packaged in a single module and mounted in the center of the steering wheel.
- The diagnostic module constantly monitors the readiness of the SRS electrical system. If the battery or cables are damaged during an accident, it supplies backup power to the air bag module.
- The igniter is a combustible device that converts electric energy into thermal energy to ignite the inflator propellant.
- Air bags will deploy if the vehicle is involved in a frontal collision of sufficient impact and the collision force is within 30 degrees on either side of the vehicle centerline.
- The total air bag deployment time from the instant of impact until the air bag is inflated is less than 160 ms.
- An accelerometer-type air bag sensor generates an analog voltage in relation to deceleration forces. The accelerometer also senses the direction of impact force.
- The clockspring electrical connector maintains electrical contact between the inflator module and the air bag electrical system.
- The air bag warning light indicates an inoperative air bag system.
- A hybrid inflator module contains a pressurized argon gas cylinder, which is punctured by the exploding propellant to inflate the air bag.
- Shorting bars connect air bag system squib terminals together when the terminal is disconnected. This will prevent accidental air bag deployment.
- Federal law expanded to require all passenger vehicles produced after 1995 be equipped with front passenger-side air bags.
- The air bag module of the multistage system uses two squibs. When one of the squibs is fired, the air bag will begin to deploy. The second squib is then fired to generate more heat so the air bag is filled faster.



## SUMMARY

### TERMS TO KNOW

Accelerometers

Air bag

Belt tension sensor (BTS)

Carriers

Crash sensors

Fifth percentile female

Fuel pump inertia switch

Hybrid air bag

Igniter

Inertia lock retractors

Inflatable knee blocker (IKB)

Multistage air bags

Pretensioners

Safing sensor

Seat track position sensor (STPS)

Squib

- Side-impact air bags can be designed to come out of the door panel, from the seat back, between the A-pillar and the headliner, or from a roof-mounted curtain in the headliner that protects both the front- and rear- seat occupants.
- Some vehicles with limited rear seating may be factory equipped to turn off the passenger air bag if it would not be safe to have it deploy.
- At this time, in order to install air bag deactivation kits or on/off switches, the vehicle owner must first obtain permission from the National Highway Traffic Safety Administration (NHTSA).
- To assure the driver and/or passenger stay in position during an accident, some vehicles are equipped with seat belt pretensioners.
- There are two ways of mounting the pretensioner—on the buckle side or retractor side of the seat belt.
- The inflatable knee blocker (IKB) deploys simultaneously with the driver's-side air bag to provide upper-leg protection and positioning of the driver.
- Occupant classification systems are a mandated requirement designed to reduce the risk of injuries resulting from air bag deployment.
- The Delphi system uses a bladder to determine weight, and the TRW system uses strain gauges. Both systems use an occupant classification module (OCM) that determines the weight classification of the front passenger and sends this information to the ORC. Also, both systems use multistage passenger-side air bags.
- The belt tension sensor (BTS) is a strain gauge-type sensor located on the seat belt anchor that is used to indicate if an infant seat is cinched into the passenger-side front seat.
- The seat track position sensor (STPS) provides information to the OCM concerning the position of the seat in relation to the air bag.

## REVIEW QUESTIONS

### Short-Answer Essays

1. Define the term *passive restraint*.
2. Describe the basic operation of automatic seat belts.
3. List and describe the design and operation of three different types of air bag system sensors.
4. List and explain two of the functions of the ORC used in air bag systems.
5. List the sequence of events that occur during air bag deployment.
6. What is the purpose of the clockspring?
7. Describe the deployment of the hybrid inflator module.
8. What is the purpose of multistage air bags?
9. Where is the side-impact air bag control module or sensor usually located?
10. List the common mounting locations of the seat belt pretensioner.

### Fill in the Blanks

1. The \_\_\_\_\_ conducts electrical signals to the air bag module while permitting steering wheel rotation.
2. In the automatic seat belt system, the \_\_\_\_\_ switches inform the module of the position of the harness.
3. The \_\_\_\_\_ is a combustible device that converts electric energy into thermal energy to ignite the inflator propellant.
4. The diagnostic module supplies \_\_\_\_\_ to the air bag \_\_\_\_\_ in the event that the battery or cables are damaged during an accident.
5. To prevent accidental deployment of the air bag, most systems require that at least \_\_\_\_\_ sensor switches be closed to deploy the air bag.
6. The frontal collision force must be within \_\_\_\_\_ degrees of the vehicle centerline to deploy the air bag.
7. An accelerometer-type air bag sensor produces an analog voltage in relation to \_\_\_\_\_.



8. Which of the following is a characteristic of the strain gauge–type occupant classification system?
- A. If the seat is empty, the PADL is illuminated.
  - B. The system uses a belt tension sensor to determine the presence of an infant seat.
  - C. The air bag will deploy if a child is determined to be sitting in the seat.
  - D. None of the above.

9. The air bag deployment loop is being discussed.

*Technician A* says if the arming sensor contacts close, this sensor completes the circuit from the inflator module to ground.

*Technician B* says if the contacts close in two crash sensors, the air bag is deployed.

Who is correct?

- A. A only
- B. B only
- C. Both A and B
- D. Neither A nor B

10. Hybrid inflator modules are being discussed.

*Technician A* says a pressure sensor in the argon gas cylinder sends a signal to the ASDM in relation to gas pressure in the cylinder.

*Technician B* says when the initiator is energized, the propellant explodes and pierces the propellant container, allowing the pressurized argon gas to escape into the air bag.

Who is correct?

- A. A only
- B. B only
- C. Both A and B
- D. Neither A nor B

# VEHICLES WITH ALTERNATIVE POWER SOURCES

### UPON COMPLETION AND REVIEW OF THIS CHAPTER, YOU SHOULD BE ABLE TO:

- Explain the basic operation of electric vehicles.
- Describe the typical operation of a hybrid vehicle.
- Explain the difference between parallel and series hybrids.
- Explain the purpose of regenerative braking.
- Describe the purpose of the 42-volt system.
- Explain the operating principles of integrated starter generator systems.
- Describe how a proton exchange membrane produces electricity in a fuel cell system.
- List and describe the different fuels that can be used in a fuel cell system.
- Describe the purpose of the reformer.
- Explain how different types of reformers operate.

## INTRODUCTION

Due to the increase in regulations concerning emissions, and the public's desire to become less dependent on foreign oil, most major automotive manufacturers have developed alternative fuel or alternative power vehicles. This chapter explores several alternative power sources. This includes a study of common hybrid systems. Also included is a discussion of the 42-volt system and its influence on the new technology of integrated starter generator (ISG) idle stop systems. In addition, the final section of this chapter covers fuel cell theories and some of the methods that manufacturers are using to approach this alternative power source. These power sources are being sold in limited numbers, or they are still in the research and development stage.

## ELECTRIC VEHICLES

Since the 1990s, most major automobile manufacturers have developed an **electric vehicle (EV)**. The EV powers its motor from a battery pack. The primary advantage of an EV is a drastic reduction in noise and emission levels. The California Air Resources Board (CARB) established a low-emission vehicles/clean fuel program to further reduce mobile source emissions in California during the late 1990s. This program-established emission standards are established for five vehicle types (Figure 16-1): conventional vehicle (CV), transitional low-emission vehicle (TLEV), low-emission vehicle (LEV), ultra low-emission vehicle (ULEV), and zero emission vehicle (ZEV). The EV meets ZEV standards. Figure 16-2 shows the basic components of an EV.

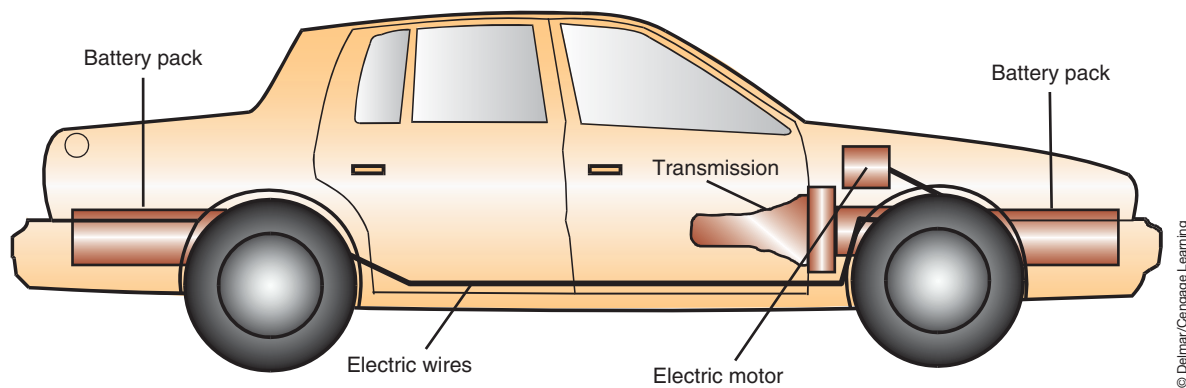
General Motors introduced the EV1 electric car to the market in 1996. The original battery pack in this car contained 26 12-volt batteries that delivered electrical energy to a three-phase

	CV	TLEV	LEV	ULEV	ZEV
NMOG	0.25*	0.125	0.075	0.040	0.0
CO	3.4	3.4	3.4	1.7	0.0
NOx	0.4	0.4	0.2	0.2	0.0

(\*) Emission standards of NMHC

© Delmar/Cengage Learning

**FIGURE 16-1** California tailpipe emission standards in grams per mile at 50,000 miles.



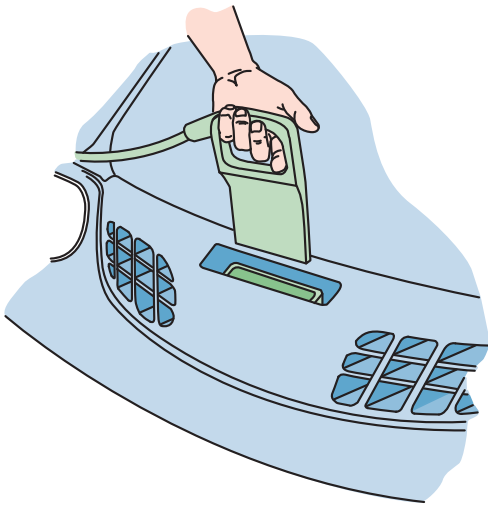
© Delmar/Cengage Learning

**FIGURE 16-2** The electric vehicle is powered by an electric motor that receives its energy from battery packs.

102-kilowatt (kW) AC electric motor. The electric motor is used to drive the front wheels. The driving range is about 70 miles (113 km) of city driving or 90 miles (145 km) of highway driving. Temperature, vehicle load, and speed affect this range. A 1.2-kW charger in the vehicle's trunk can be used to recharge the batteries. This charger takes about 15 hours to fully recharge the batteries. An external Delco Electronics' MAGNE CHARGE 6.6 kW inductive charger operating on 220 volts/30 amperes can recharge the batteries in 3 to 4 hours (Figure 16-3). The weatherproof plastic paddle is inserted into the charging port located at the front of the vehicle. Power is transferred by magnetic fields.

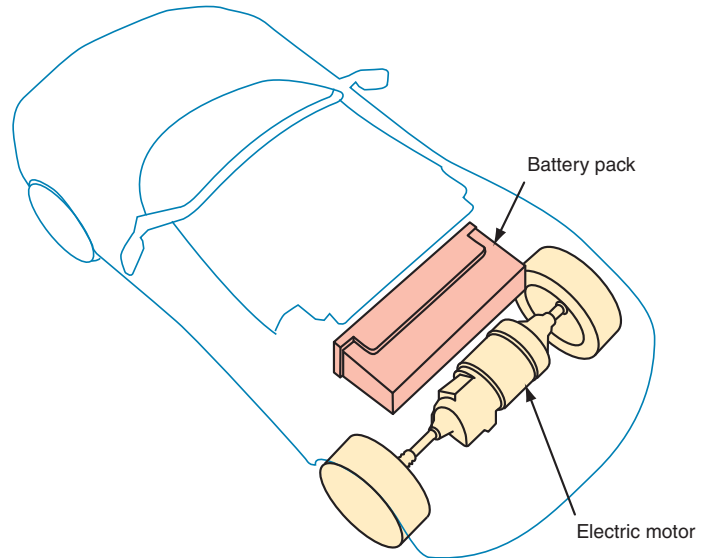
If the batteries are fully charged, the EV1 accelerates from 0 to 60 mph (97 km/h) in 9 seconds and has a top speed of 80 mph (129 km/h). The EV1 is equipped with a Galileo electronic brake system that employs a computer and sensors at each wheel to direct power-assist braking, regenerative/friction brake blending, four-wheel antilock braking, traction assist, tire pressure monitoring, and system diagnostics. In 1998, GM installed nickel/metal/hydride batteries in the EV1 vehicles, which extended the driving range between battery charges to 160 miles (257 km).

The driving range of EVs is their biggest disadvantage. Much research is being done to extend the range and to decrease the required recharging times. Currently, the use of nickel/metal/hydride or lead-acid batteries and permanent magnet motors has extended the operating range. Another disadvantage is that the battery pack adds substantial weight to the vehicle (Figure 16-4). Other features, such as **regenerative braking** and highly efficient accessories (such as a heat pump for passenger heating and cooling), are also being installed on EVs. Regenerative braking means that the braking energy is turned back into electricity instead of heat. Other disadvantages are the cost of replacement batteries and the danger associated with the high voltage and high frequency of the motors.



© Delmar/Cengage Learning

FIGURE 16-3 Recharging the EV.



© Delmar/Cengage Learning

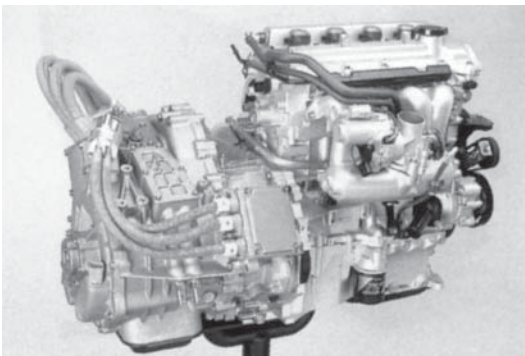
FIGURE 16-4 Positioning the EV's battery pack for installation.

## HYBRID VEHICLES

The first alternative vehicle attempted was the EV, which had zero emissions and ran primarily on battery power. However, the battery has a limited energy supply and restricts the traveling distance. This limitation was a major stumbling block to most consumers; thus the use of EVs is mainly limited to fleets. One method to improve the EV was the addition of an onboard power generator that is assisted by an internal combustion engine. The result was the **hybrid electric vehicle (HEV)**. An HEV has two different power sources. In most hybrid vehicles, the power source consists of a small displacement gasoline or diesel engine and an electric motor. The addition of the internal combustion engine meant the vehicle could not be classified as a ZEV. However, it does reduce emission levels significantly and increases fuel economy.

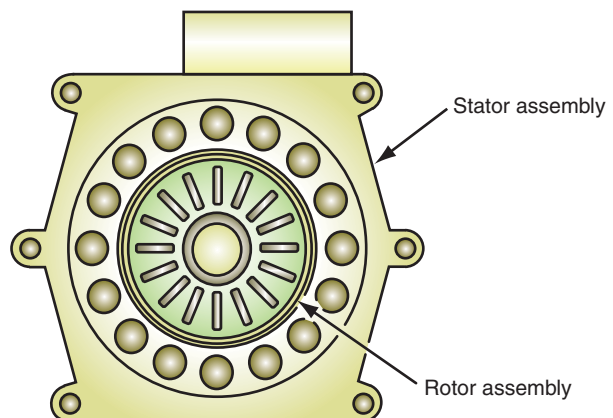
Basically, the HEV relies on power from the electric motor, the engine, or both (Figure 16-5). When the vehicle moves from a stop and has a light load, the electric motor moves the vehicle. Power for the electric motor comes from stored electricity in the battery pack. During normal driving conditions, the engine is the main power source. Engine power is also used to rotate a generator that recharges the storage batteries (Figure 16-6). The output from the generator can also be used to power the electric motor, which is run to provide additional power to the powertrain (Figure 16-7). A computer controls the operation of the electric motor depending on the

**Shop Manual**  
Chapter 16, page 673



© Delmar/Cengage Learning

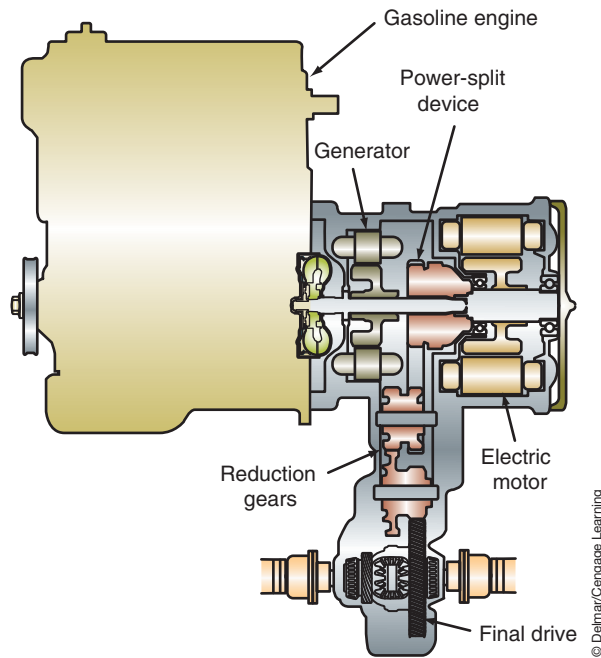
FIGURE 16-5 Hybrid power system.



© Delmar/Cengage Learning

FIGURE 16-6 Engine power is also used to rotate a generator that recharges the storage batteries and drives the vehicle. The rotor assembly is a very powerful magnet that induces voltage into the stator windings as it is rotated.





**FIGURE 16-7** Hybrid power system with gasoline engine and electric propulsion motor.

power needs of the vehicle. During full throttle or heavy load operation, additional electricity from the battery is sent to the motor to increase the output of the powertrain.

The components of a typical hybrid vehicle include:

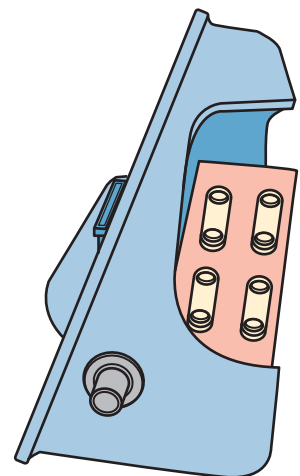
- **Batteries.** Some types of batteries that are being used or experimented with now are the lead-acid battery, the nickel-metal hydride battery, and the lithium-ion battery. In the development of the battery, thermal management must be taken into consideration. The temperature can vary from module to module so the performance of the battery is dependent on the temperature. An imbalance in temperature will affect the power and capacity of the battery, the charge acceptance during regenerative braking, and vehicle operation. Also, passenger safety is a major concern. The batteries must be kept in sealed containers in order to ensure complete protection. The Toyota Prius (Figure 16-8) seals its non-caustic, nonflammable nickel-metal hydride battery in a carbon composite case positioned in the rear of the vehicle (Figure 16-9).

**Shop Manual**

Chapter 16, page 677



**FIGURE 16-8** Toyota Prius was the world's first mass-produced hybrid vehicle.



**FIGURE 16-9** Battery pack.

- *Electric motors.* One of the sources of power is the electric motor. The motor converts electrical energy to mechanical energy. This mechanical energy is what drives the wheels of the vehicle. This motor is designed to allow for maximum torque at low rpm. This gives the electric motor the advantage of having better acceleration than the conventional motor.
- *Regenerative braking.* About 30% of the kinetic energy lost during braking is in heat. When decreasing acceleration, regenerative braking helps minimize energy loss by recovering the energy used to brake. It does this by converting rotational energy into electrical energy through a system of electric motors and generators. Regenerative braking assumes some of the stopping duties from the conventional friction brakes and uses the electric motor to help stop the car. To do this, the electric motor operates as a generator when the brakes are applied, recovering some of the kinetic energy and converting it into electrical energy. The motor becomes a generator by using the kinetic energy of the vehicle to store power in the battery for later use.
- *Ultra capacitors.* The **ultra capacitor** is a device that stores energy as electrostatic charge. It is the primary device in the power supply during hill climbing, acceleration, and the recovery of braking energy. To create a larger storage capacity for the ultra capacitors, the surface area must be increased and, in turn, the voltage is increased. However, because the voltage drops as energy is discharged, additional electronics are required to maintain a constant voltage.

## Propulsion

There are two typical ways to arrange the flow of power in an HEV. If the combustion engine is capable of turning the drive wheels as well as the generator, then the vehicle is referred to as a **parallel hybrid** (Figure 16-10). In a parallel hybrid configuration, there is a direct mechanical connection between the engine and the wheels. Both the engine and the electric motor can turn the transmission at the same time.

There is a further distinction between a **mild parallel hybrid** and a **full parallel hybrid** vehicle. A mild parallel hybrid vehicle has an electric motor that is large enough to provide regenerative braking, instant engine start-up, and a boost to the combustion engine. A full parallel hybrid vehicle uses an electric motor that is powerful enough to propel the vehicle on its own.

Other configurations of the parallel hybrid vehicle include the use of an engine to power one axle and an electric motor to power the other (Figure 16-11). Another concept is to use a combination where the engine, coupled with an electric motor, powers one axle, and another electric motor powers the other axle (Figure 16-12).

Most parallel hybrid vehicles use the electric motor to accompany the engine to help drive the wheels. For example, the engine is used for long driving periods, while the electric motor is used for short, low-intensity drives. In other words, the engine is ideal for highway driving, and the electric motor is ideal for a trip around town. The electric motor also

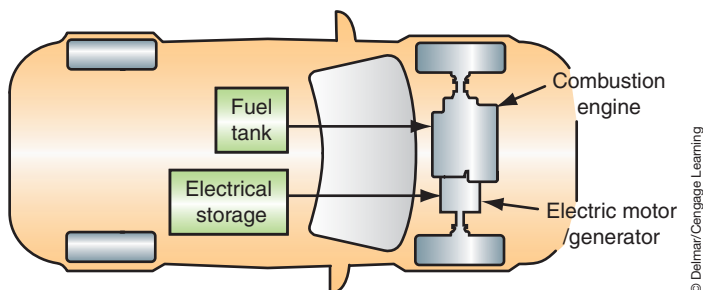
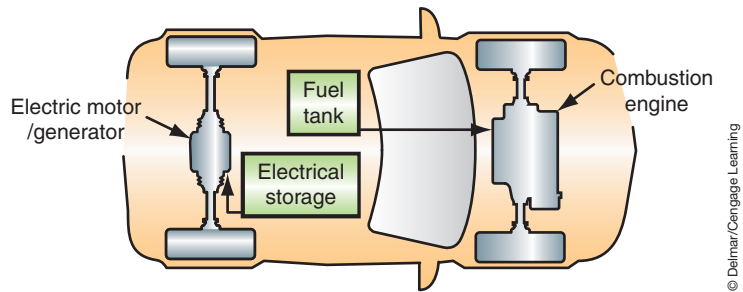
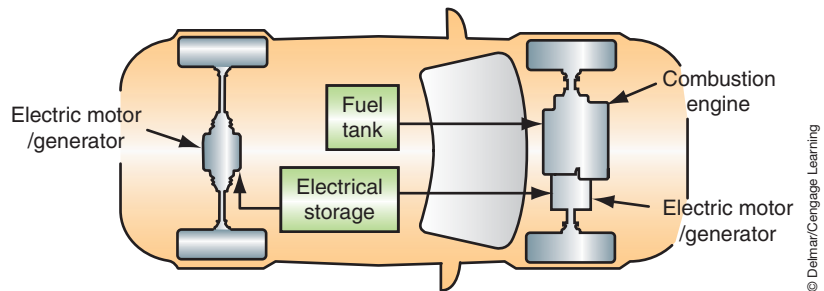


FIGURE 16-10 Parallel hybrid configuration.



**FIGURE 16-11** Parallel hybrid configuration using an engine to power one axle, and an electric motor to power the other.

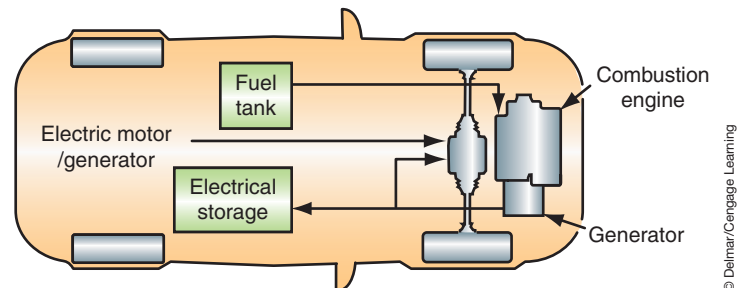


**FIGURE 16-12** Parallel hybrid configuration using a combination where the engine coupled with an electric motor powers one axle and another electric motor powers the other axle.

provides the vehicle with acceleration. This acceleration, however, is only sustained until the vehicle reaches a certain speed. After this speed is reached, the engine is started and replaces the electric motor. The parallel hybrid combines the alternator, starter, and wheels to create a system that will start the engine, electronically balance it, take power from the engine and turn it into electricity, and provide extra power to the driveline when a power assist is needed for hill climbing or quick acceleration.

In the **series hybrid** vehicle, there is no mechanical connection between the engine and the wheels. The engine turns a generator, and the generator will either charge the batteries or power the electric motor, which in turn drives the transmission. Therefore, the engine never directly powers the automobile (Figure 16-13).

The power used to give the vehicle motion is transformed from chemical energy into mechanical energy, then into electrical energy, and finally back to mechanical energy to drive the wheels. This configuration is efficient in that it never idles. The automobile turns off



**FIGURE 16-13** Series hybrid configuration.

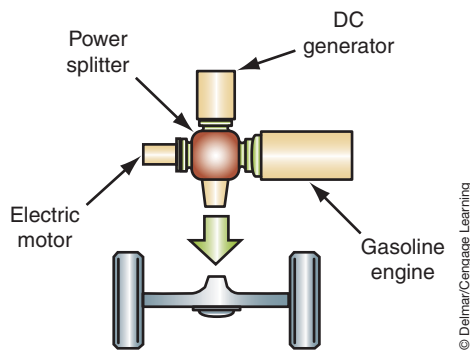
completely at rest, such as at a stop sign or traffic light. This feature greatly reduces emissions. There is a variety of options in the configuration and mounting of all the components. Some series hybrid vehicles do not use a transmission.

## HEV Examples

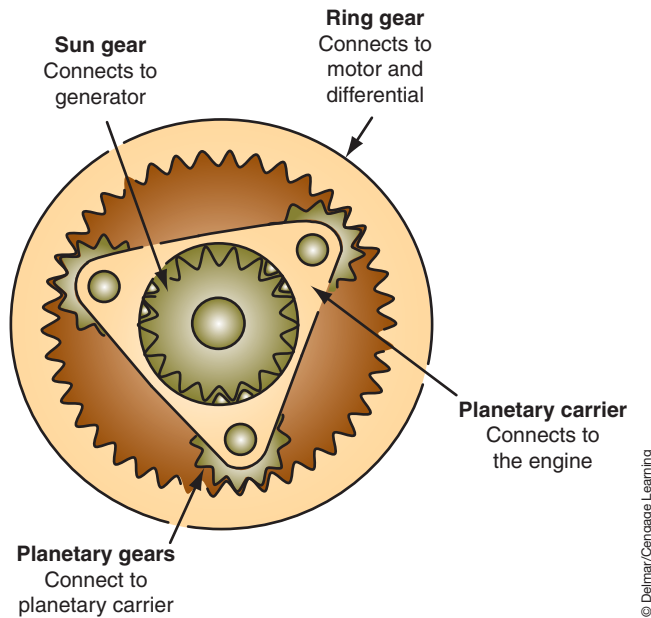
The Toyota Prius is considered a super ultra low-emissions vehicle (SULEV), meaning that it is 90% cleaner than an ULEV. The Prius uses a combined hybrid-electric structure to supply power. This system uses a combination of an internal combustion engine and an electric motor to turn the electrically controlled continuous variable transmission (ECCVT). However, the Prius can also accelerate using both the engine and the electric motor and can run solely on the electric motor. This is called a power split device (Figure 16-14).

Using a set of planetary gears (Figure 16-15), the vehicle can operate like a parallel vehicle in that either the electric motor or the gasoline engine powers the vehicle or they both do. However, the vehicle can also operate as a series hybrid where the engine can operate independently of the vehicle speed, either charging the batteries or providing power to the wheels when needed.

Operating the engine independently of the vehicle speed means that even though the vehicle is traveling at highway speeds, the engine can be close to idle speed since it is only acting as a generator.



**FIGURE 16-14** The power splitter allows for acceleration using both the engine and the electric motor and to be able to run solely on the electric motor.



**FIGURE 16-15** Planetary gears are used to transfer power to the drive wheels.

All the propulsion and auxiliary components of the Prius are packaged under the hood. The electric motor is rated at 33 kW and battery power is 21 kW. The nickel-metal hydride battery pack is located between the rear seatback and the trunk.

The Prius is equipped with a variable valve timing four-cylinder engine. The generator also works as the starter of this engine. Gear shifting is not required because the planetary system acts as a continuously variable transmission to keep engine rpm in the range of best efficiency. Instead of a normal transmission, the engine drives the planet carrier of a planetary gear set. The sun gear of that set connects to a motor/generator and the ring gear drives both the front wheels and a second motor/generator.

The Prius is also equipped with a “drive-by-wire” accelerator. The driver inputs to the motor management how much speed is requested. The management system then decides where the necessary power should come from: the engine, the battery, or both. The same accounts for the brake-by-wire system: The driver calls for the appropriate amount of retardation, and the motor management coordinates this between the wheel brakes and the regenerative braking system. The computer also makes sure that the generator runs frequently enough to keep the battery charged.

When the battery is fully charged and the engine temperature is acceptable, the engine can be shut off (if the vehicle speed is low enough). If the driver gently presses the accelerator, the vehicle is moved by battery power. If the driver requests a quicker acceleration, the engine is started and powers the vehicle. In normal driving, the Prius maintains the battery state-of-charge within a narrow window. However, driving the vehicle under heavy loads for an extended time may deplete the battery charge.

The Honda Insight is also a parallel hybrid vehicle. In this system, the gasoline engine provides the majority of the power. The electric motor is used to help the gasoline engine provide additional power during acceleration. The Insight uses regenerative braking technology to capture energy lost during braking. The Insight also has a lightweight engine that uses **lean burn technology** to maximize its efficiency. Lean burn technology, developed in the 1960s, uses high air–fuel ratios to increase fuel efficiency.

The Honda Civic Hybrid uses an integrated motor assist (IMA) system to power the vehicle. The system comprises a gasoline and electric motor combination. The electric motor is a source of additional acceleration and functions as a high-speed starter. The electric motor also acts as a generator for the charging system used during regenerative braking. This way the Civic Hybrid ensures efficiency by capturing lost energy by using regenerative braking, much like the Prius and the Insight.

## 42-VOLT SYSTEMS

The idea of 42-volt systems has been around for over 20 years. The first production vehicle that used the 42-volt system was the 2002 Toyota Crown Sedan, which is only sold in the Japanese market. Although the use of 42-volt systems is very limited at the current time, the technology learned has been applied to the hybrid systems. In this section, we will discuss the 42-volt system as it is used for vehicle electrical systems initially then progress to the use of the ISG on some mild-hybrid vehicles.

As you have probably come to realize, the increased use of electrical and electronic accessories in today’s vehicles has about tapped the capabilities of the 12-volt/14-volt electrical system. Electronic content in vehicles has been rising at a rate of about 6% per year. It’s been estimated that by the end of the decade the electronic content will be about 40% of the total cost of a high-line vehicle. The electrical demands on the vehicle have risen from about 500 watts in 1970 to about 4,000 watts in 2005. It is estimated that in 10 years the demand may reach 10,000 watts.

One way to meet the higher electrical demands would be to increase the amperage. This has been the approach over the past 30 years. Years ago it was common for a generator to

The system is called 12 volt/14 volt because the battery is 12 volts but the charging system delivers 14 volts. The 42-volt system is actually a 36-volt/42-volt system.

have a rating of 35 to 50 amperes. Today, most manufacturers use a 150 ampere generator. However, just increasing the amperage output of the generator will not suffice to meet the 10,000-watt demand. Using Ohm's law, in order to obtain 10,000 watts with a 14-volt generator the output would have to be 714 amperes. The more realistic alternative is to increase the voltage. As a result, vehicle manufacturers are developing a 36-volt/42-volt system that incorporates a 42-volt generator charging a 36-volt battery. To meet the 10,000-watt demand in a 42-volt system, 238 amperes are required.

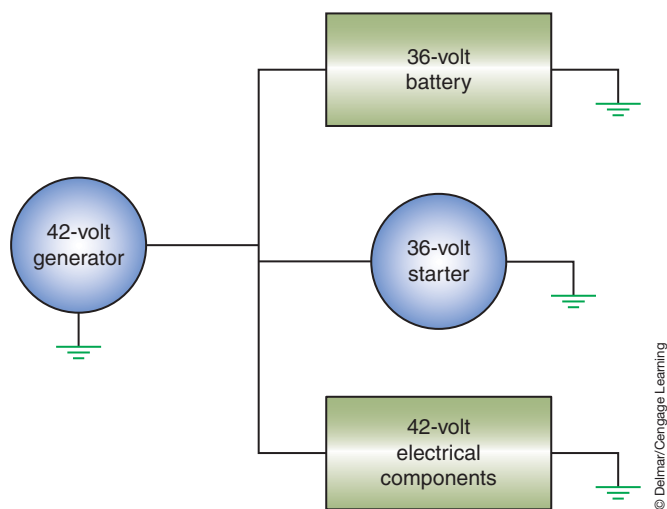
An additional benefit that may be derived from the use of a 42-volt system is that it allows manufacturers to electrify most of the inefficient mechanical and hydraulic systems that are currently used. The new technology will allow electro-mechanical intake and exhaust valve control, active suspension, electrical heating of the catalytic converters, electrically operated coolant and oil pumps, electric air conditioning compressor, brake-by-wire, steer-by-wire, and so on to be utilized. Studies have indicated that as these mechanical systems are replaced, fuel economy will increase by about 10%. In addition, emissions will decrease.

Additional fuel savings can also be realized due to the more efficient charging system used for the 42-volt system. Current 14-volt generators have an average efficiency across the engine speed range band of less than 60%. This translates to about 0.5 gallons (1.9L) of fuel for 65 miles (104.6 km) of driving to provide a continuous electrical load of 1,000 watts. With a 42-volt generator, the fuel consumption can be reduced the equivalent of up to 15% in fuel savings. The 42-volt generator will be discussed later in this chapter.

Changing to 42-volt system provides three times as much generator power as the current system and will deliver as much as 30,000 watts. Since the increase in voltage results in a two-thirds reduction in amperage, the size of components can be reduced. Also, a significant reduction in the vehicle wiring size and weight can be realized.

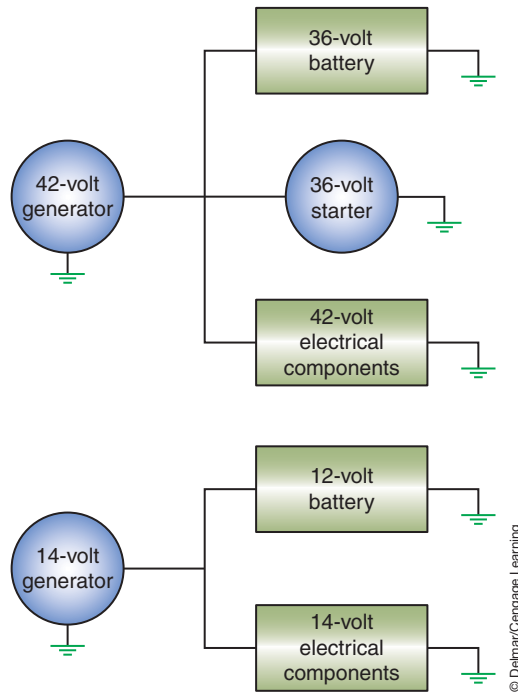
There are several methods that are being used and developed for the electrical architecture of the 42-volt system. One method is a simple **single 42-volt system** that is very similar to the current 12-volt/14-volt system (Figure 16-16). The challenge with this type of system is that all of the vehicle's electrical system will require redesigning to handle the 42 volts.

Due to the initial costs of implementing a single 42-volt system, a **dual-voltage system** is also being designed. With this architecture, the 42-volt system would power those electrical accessories that would require or benefit from the higher voltage. The remainder of the loads would remain on 14 volts. There are several ways to implement a dual-voltage system.



**FIGURE 16-16** The single voltage system is similar to the conventional 12-volt/14-volt system.

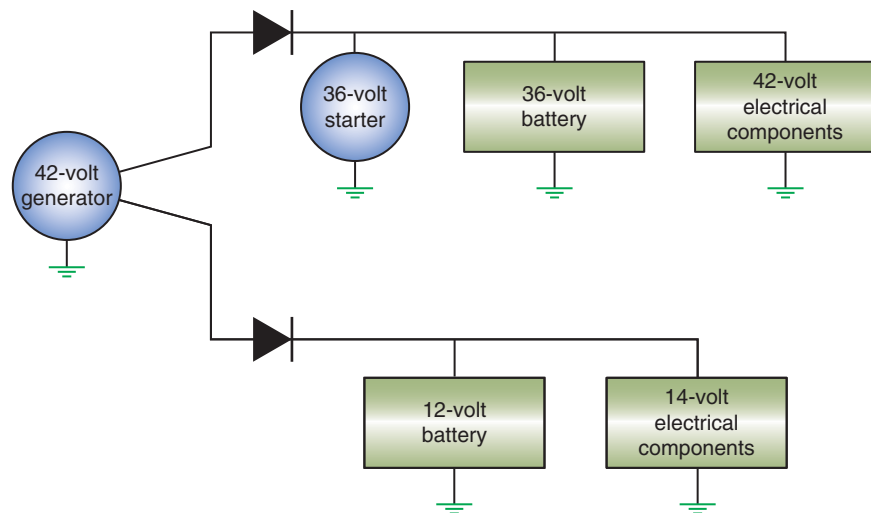




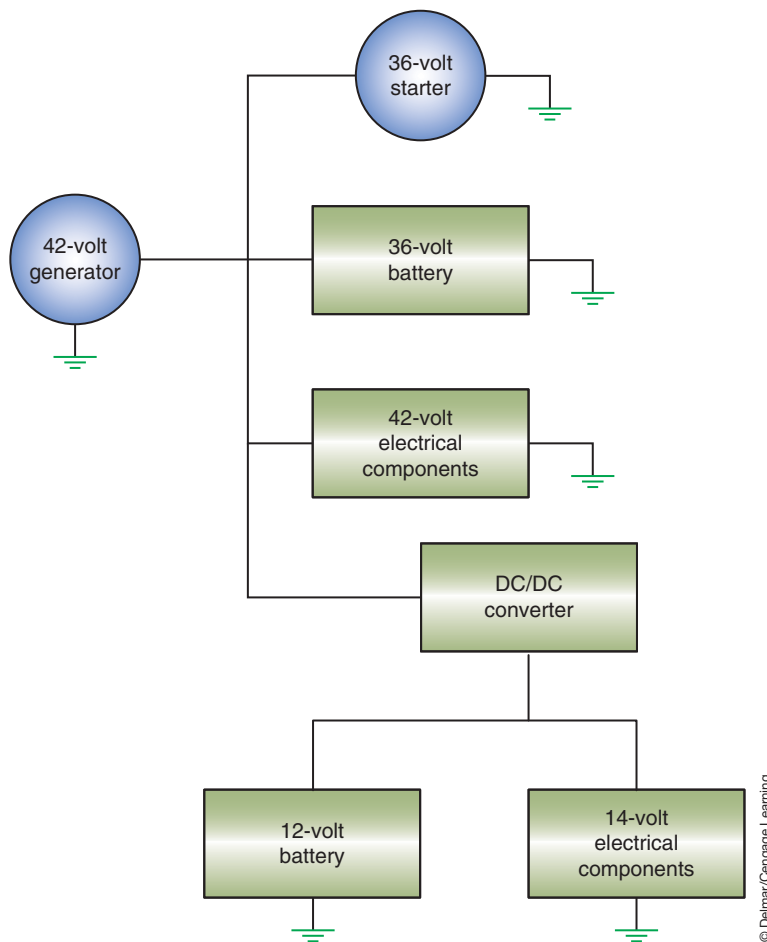
**FIGURE 16-17** The dual-voltage system separates the electrical systems.

One method is to use **dual-generator system** (Figure 16-17). One generator operates at 42 volts, while the other operates at 14 volts. Another system is the **dual-stator, dual-voltage system** (Figure 16-18). In this system, dual voltage is produced from a single alternator that has two output voltages.

Another design uses a **DC/DC converter** (Figure 16-19). The DC/DC converter is configured to provide a 14-volt output from the 42-volt input. The 14-volt output can be used to supply electrical energy to those components that do not require 42 volts.



**FIGURE 16-18** The dual-stator, dual-voltage system splits the electrical systems by using two outputs from a single generator.



**FIGURE 16-19** The DC/DC converter uses the 42-volt input and converts it to a 14-volt output.



## A BIT OF HISTORY

In 1955, automobile manufacturers started to move from 6-volt electrical systems to the present 12-volt system. The change was due to the demand for increased power to accommodate a greater number of electrical accessories. In 1955, the typical car wiring harness weighed 8 to 10 pounds and required approximately 250 to 300 watts. In 1990, the typical car wiring harness weighed 15 to 20 pounds and required over 1,000 watts. In 2000, the typical car wiring increased to weigh between 22 and 28 pounds and required over 1,800 watts. The conventional 14-volt generator is capable of producing a maximum output of 2,000 watts.

As simple as it may seem to convert from a 12-volt/14-volt system to a 36-volt/42-volt system, many challenges need to be overcome. It is not as simple as adding a higher voltage output generator and expecting the existing electrical components to work. One of the biggest hurdles is the light bulb. Current 12-volt lighting filaments can't handle 42 volts. The dual-voltage systems can be used as a step toward full 42-volt implantation. However, dual-voltage systems are expensive to design. Another aspect of the 42-volt system is service technician training to address aspects of arcing, safety, and dual-voltage diagnostics.

Arcing is perhaps the greatest challenge facing the design and use of the 42-volt system. In fact, some manufacturers have abandoned further research and development of the system because of the problem with arcing. In the conventional 14-volt system, the power level is low enough that it is almost impossible to sustain an arc. Since there isn't enough electrical energy involved, the arcs collapse quickly and there is less heat buildup. Electrical energy in an arc at 42 volts is significantly greater and is sufficient to maintain a steady arc. The arc from a 42-volt system can reach a temperature of 6000°F (3,316°C).

Voltage regulation also presents a challenge, expectably in dual-voltage systems. As mentioned earlier on method of dual-voltage control is the use of DC/DC converters. Another method is pulse-width modulation (PWM). An advantage of this method is it reduces most of the arcing problems associated with higher voltage. This is because there is not a true steady stream of current with PWM. This results in the arc collapsing quickly and in the reduction of heat.

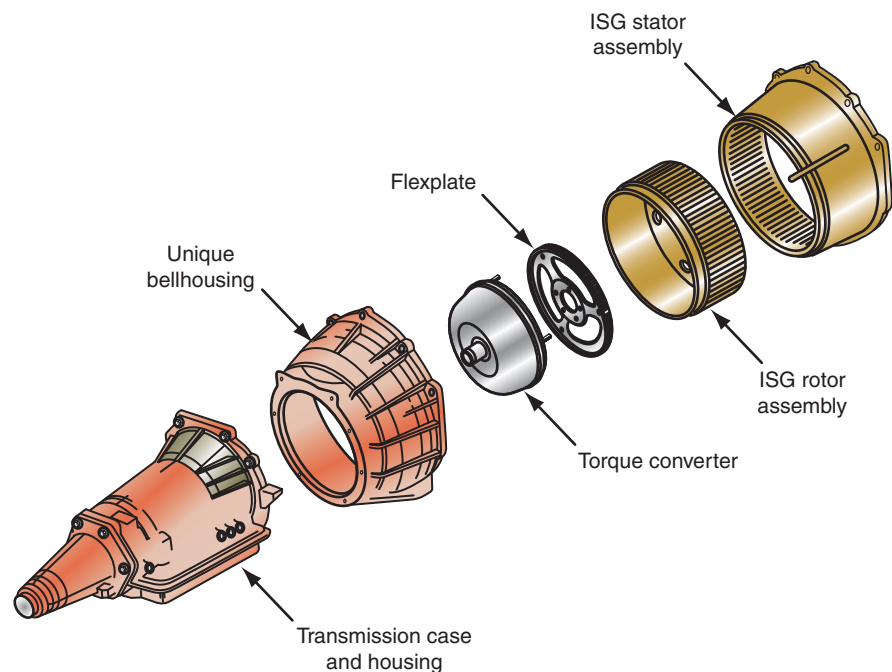
One of the newest technologies to emerge from the research and development of the 42-volt system is the **integrated starter generator (ISG)**. Although this system can be used in conventional engine powered vehicles, one of the key contributors to the Hybrid's fuel efficiency is its ability to automatically stop and restart the engine under different operating conditions. A typical Hybrid vehicle uses a 14-kW electric induction motor or ISG between the engine and the transmission (Figure 16-20). The ISG performs many functions such as fast, quiet-starting, automatic engine stops/starts to conserve fuel, recharges the vehicle batteries, smoothes driveline surges, and provide regenerative braking.

Hybrid vehicles utilize the automatic stop/start feature to shut off the engine whenever the vehicle is not moving or when power from the engine is not required. Usually this feature is activated when the vehicle is stopped, no engine power is required, and the driver's foot is on the brake pedal. On manual transmission–equipped vehicles, this feature may be activated when the vehicle is stopped, no engine power is required, the transmission is in neutral, and the clutch pedal is released. Once the driver's foot is removed from the brake pedal (or the clutch is engaged), the starter automatically restarts the engine in less than one-tenth of a second. To further save fuel and reduce emissions, the engine is accelerated to idle speed by the starter-generator prior to the start of the combustion process and the injection of fuel.

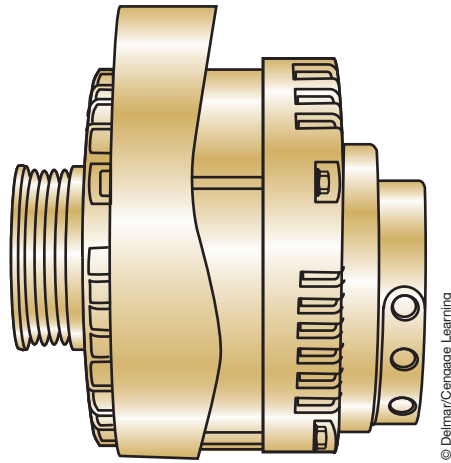
The ISG can also convert kinetic energy to DC voltage. When the vehicle is traveling downhill and there is zero load on the engine, the wheels can transfer energy through the transmission and engine to the ISG. The ISG then sends this energy to the battery for storage and use by the electrical components of the vehicle.

Most systems use a 42-volt ISG system since the power requirements of automatic stop/start are higher than the 12-volt system can provide. Currently there are two main system designs.

The first design uses a **belt alternator starter (BAS)** that is about the same size as a conventional generator and is mounted in the same way (Figure 16-21). BASs have a maximum power output of around 5 kW. Two types of BASs are being designed; permanent magnet and induction BAS.



**FIGURE 16-20** The ISG is usually located between the engine and the transmission in the bellhousing.



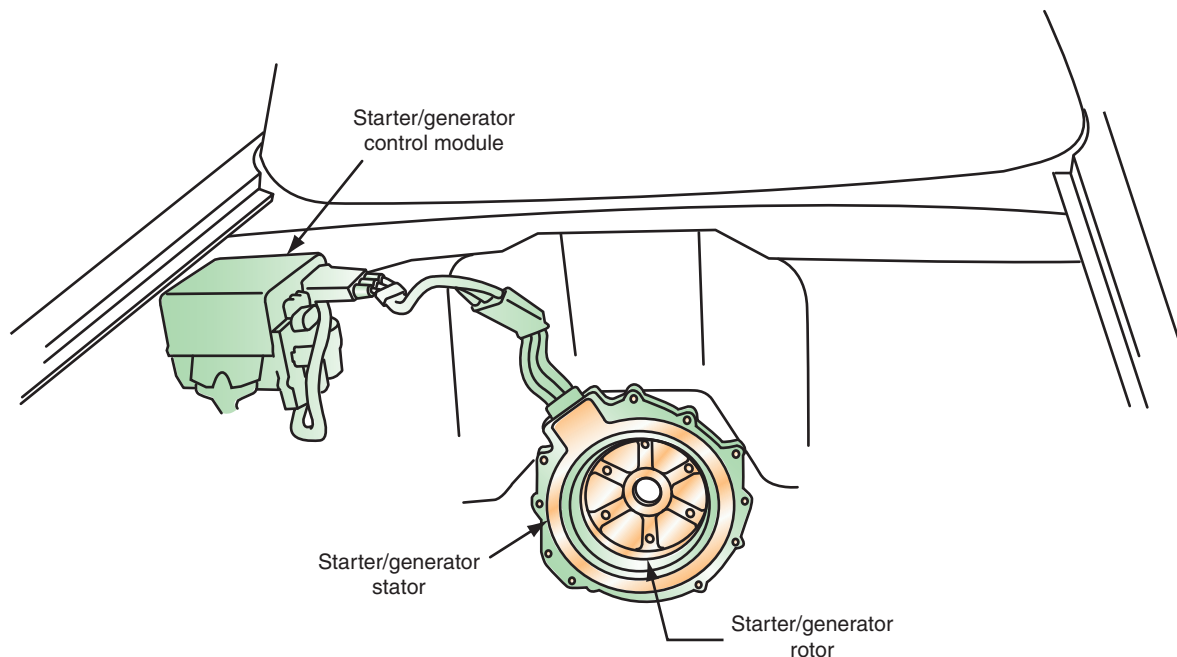
**FIGURE 16-21** The belt starter generator looks very similar to a conventional generator.

© Delmar/Cengage Learning

The second design is to mount the ISG at either end of the crankshaft. Most designs have the ISG mounted at the rear of the crankshaft between the engine and transmission. In some systems, the ISG may take the place of the engine flywheel. The ISG mounted in this method is larger than the BSG and is able to produce an output of 6 to 15 kW.

The ISG is a three-phase AC motor. At low vehicle speeds, the ISG provides power and torque to the vehicle. It also supports the engine, when the driver demands more power. During vehicle deceleration, ISG regenerates the power that is used to charge the traction batteries.

The ISG includes a rotor and stator that is located inside the transmission bellhousing (Figure 16-22). The stator is attached to the engine block and coils that are formed by laser-welding copper bars. Conventional generators use winding of copper wire for their stator. The rotor is bolted to the engine crankshaft.



**FIGURE 16-22** The ISF stator and rotor assembly.

© Delmar/Cengage Learning

Both the BAS and the ISG use the same principle to start the engine. Current flows through the stator windings it generates magnetic fields in the rotor. This will cause the rotor to turn, thus turning the crankshaft and starting the engine. In addition, this same principle is used to assist the engine as needed when the engine is running.

A **starter generator control module (SGCM)**, also called a **high-voltage ECU (HV ECU)** is used to control the flow of torque and electrical energy. Remember that torque and energy can go into or out of the ISG. The function of the SGCM is to control the engine cranking, torque, speed, and active damping functions.

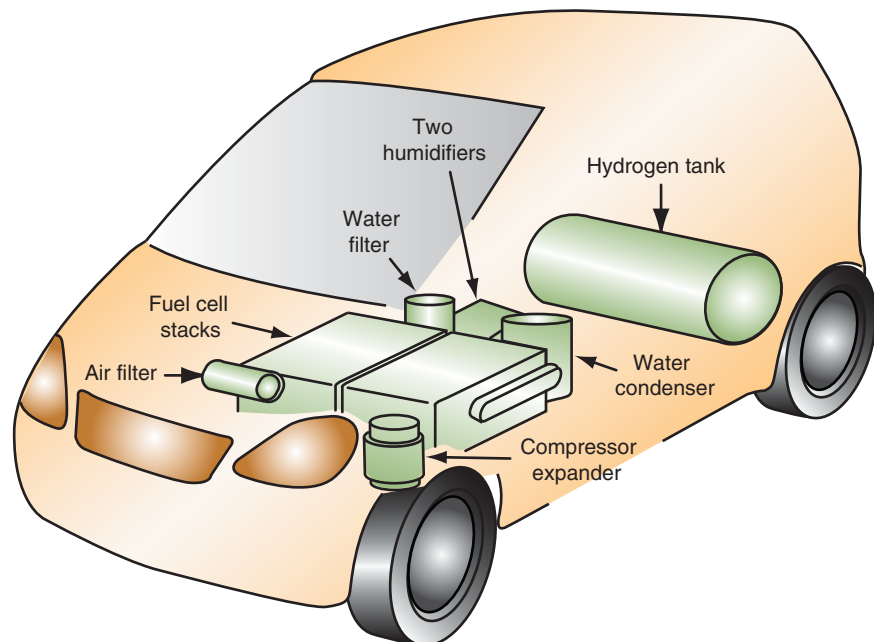
Our discussion up to this point has centered on the use of 42 volts for the ISG system. It is important to note that the hybrid system could work on 42 volts or 300 volts. Also, the voltage used to start the engine and to operate the electric motors is AC current.

## FUEL CELLS

A **fuel cell** produces current from hydrogen and aerial oxygen. Fuel cell–powered vehicles have a very good chance of becoming the vehicles of the future. They combine the reach of conventional internal combustion engines with high efficiency, low fuel consumption, and minimal or no pollutant emissions. At the same time, they are extremely quiet. Because they work with regenerative fuel such as hydrogen, they reduce the dependence on crude oil and other fossil fuels.

A fuel cell–powered vehicle (Figure 16-23) is basically an EV. Like the EV, it uses an electric motor to supply torque to the drive wheels. The difference is that the fuel cell produces and supplies electric power to the electric motor instead of the batteries. Most vehicle manufacturers and several independent laboratories are involved in fuel cell research and development programs. Manufacturers have produced a number of prototype fuel cell vehicles, with many being placed in fleets in North America and Europe.

Fuel cells electrochemically combine oxygen from the air with hydrogen to produce electricity. The oxygen and hydrogen are fed to the fuel cell as “fuel” for the electrochemical reaction. There are different types of fuel cells but the most common type is the **proton exchange membrane (PEM)**. Normally, hydrogen and oxygen bond with a loud bang but in fuel cells a



© Delmar/Cengage Learning

**FIGURE 16-23** Fuel cell vehicle components. Technology has allowed engineers to design fuel cell vehicles without the loss of passenger and cargo space.

special PEM impedes the oxyhydrogen gas reaction by ensuring that only protons ( $H^+$ ) and not elemental hydrogen molecules ( $H_2$ ) react with the oxygen.

## How the Fuel Cell Works

The PEM fuel cell is constructed like a sandwich (Figure 16-24). The electrolyte is situated between two electrodes of gas permeable graphite paper. The electrolyte is a polymer membrane. Hydrogen is applied to the anode side of the PEM and ambient oxygen is applied to the cathode side (Figure 16-25). The membrane keeps the distance between the two gases and provides a controlled chemical reaction.

The anode is the negative post of the fuel cell. It conducts the electrons that are freed from the hydrogen molecules so that they can be used in an external circuit. It has channels etched into it that disperse the hydrogen gas evenly over the surface of the catalyst. The cathode is the positive post of the fuel cell. It also has channels etched into it that distribute the oxygen to the surface of the catalyst. It also conducts the electrons back from the external circuit to the catalyst where they can recombine with the hydrogen ions and oxygen to form water.

A fine coating of platinum is applied to the foil to act as a catalyst. This is used to accelerate the decomposition of the hydrogen atoms into electrons and protons (Figure 16-26). The catalyst is rough and porous so that the maximum surface area of the platinum can be exposed to the hydrogen or oxygen. The platinum-coated side of the catalyst faces the PEM.

The PEM is the electrolyte. This specially treated material (which looks similar to ordinary kitchen plastic wrap) only allows the protons to move across from the anode to the cathode (Figure 16-27). As a result, the anode will have a surplus of electrons and the cathode has a surplus of protons. If the anode and cathode are connected outside of the cell, current flows

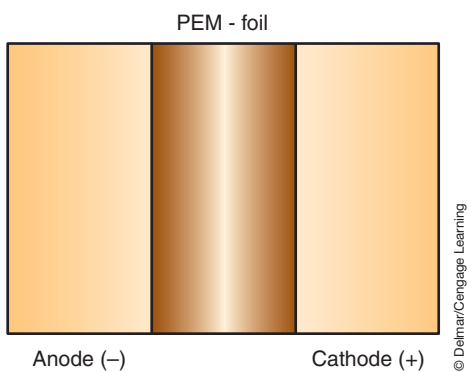


FIGURE 16-24 The PEM foil.

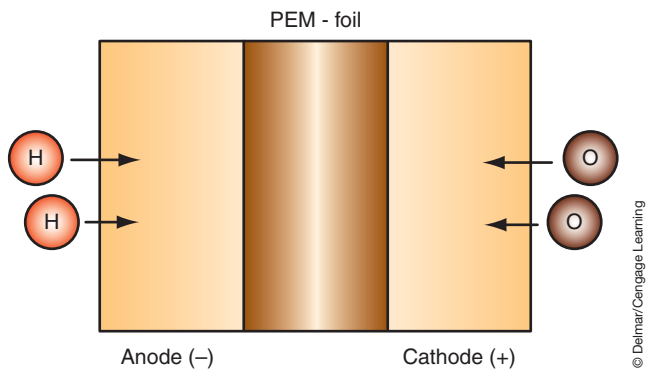


FIGURE 16-25 Hydrogen is applied to the anode side of the PEM, while oxygen applied to the cathode side.

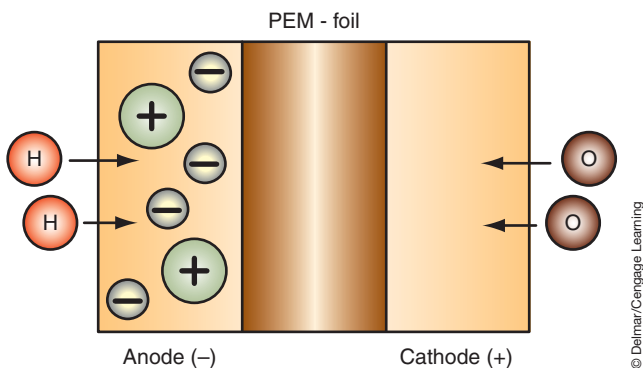


FIGURE 16-26 The catalyst breaks down the  $H_2$  into protons and electrons.

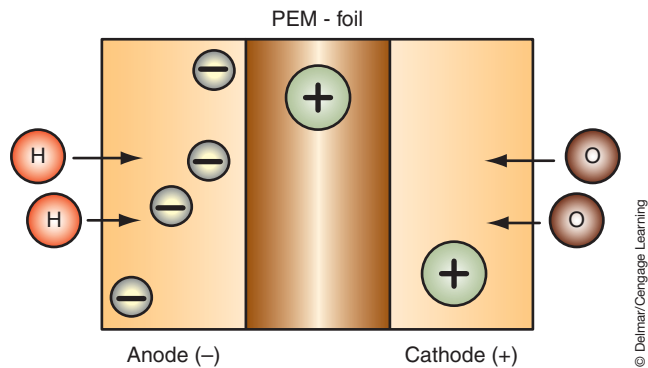
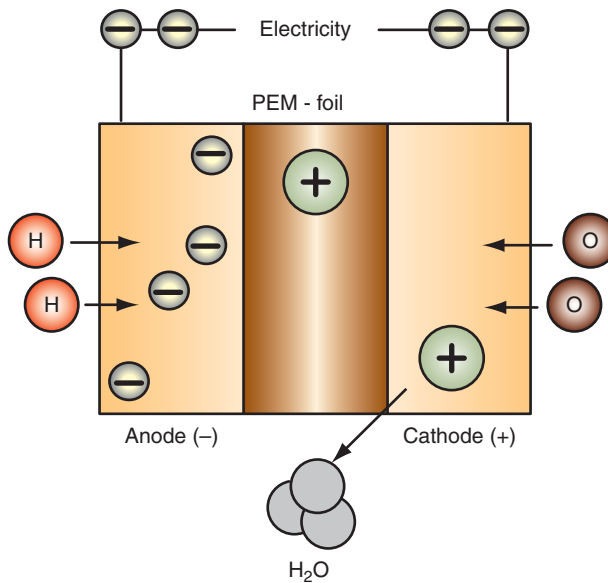


FIGURE 16-27 The PEM foil only allows the protons to migrate to the cathode, leaving the electrons on the anode.



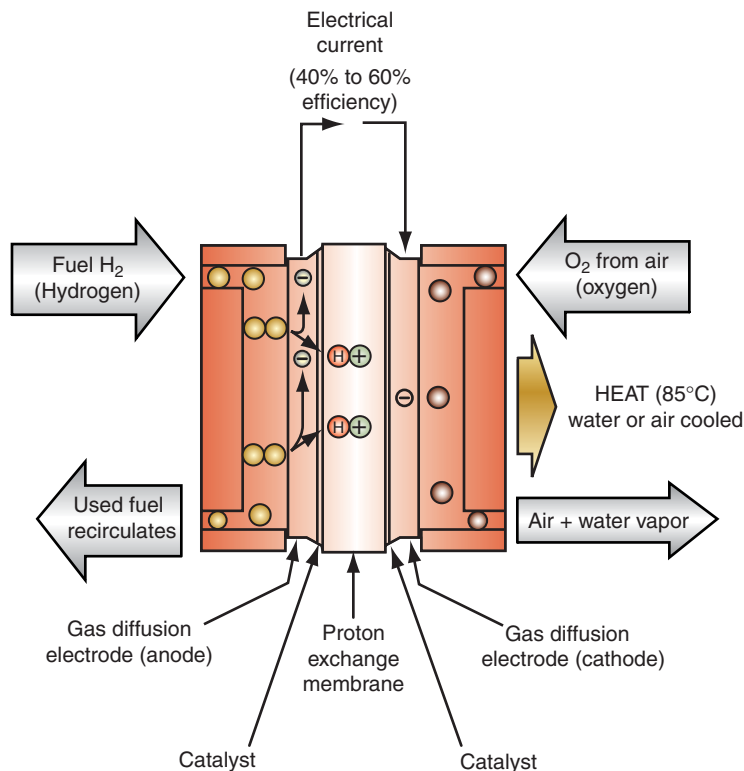


© Delmar/Cengage Learning

**FIGURE 16-28** With an excess amount of electrons on the anode and an excess amount of protons on the cathode, current flows through an external conductor. The electrons then react with the protons and oxygen to produce water.

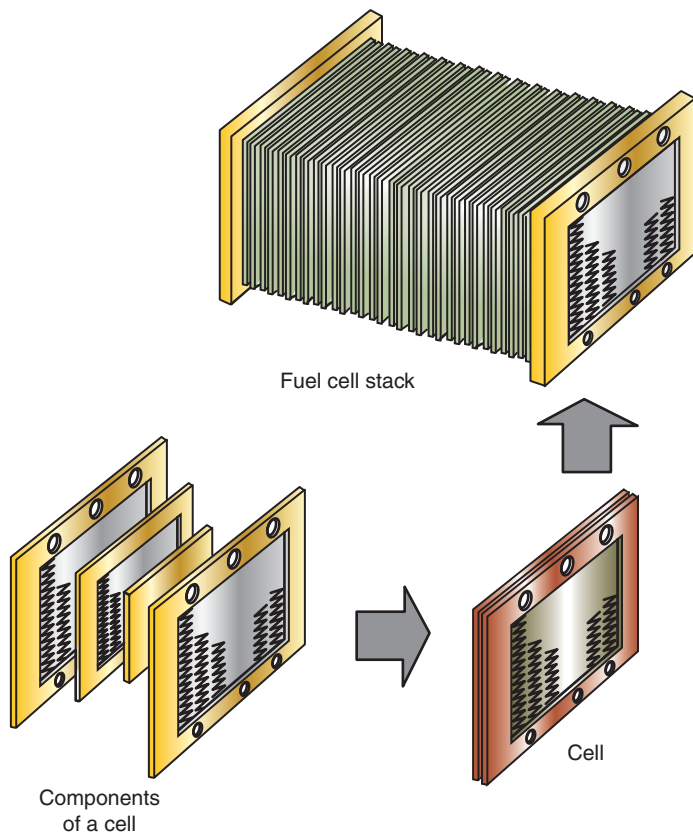
through the conductor (Figure 16-28). The electrons will move through the conductor to the cathode. The electrons then recombine with the protons and the oxygen to produce water.

The entire process is illustrated in Figure 16-29. Pressurized hydrogen gas ( $H_2$ ) enters the fuel cell on the anode side. This gas is forced through the catalyst by the pressure. When an  $H_2$  molecule comes in contact with the platinum on the catalyst, it splits into two  $H^+$  ions and



© Delmar/Cengage Learning

**FIGURE 16-29** PEM fuel cell.



**FIGURE 16-30** PEM fuel cell stack.

© Delmar/Cengage Learning

two electrons ( $e^-$ ). The electrons are conducted through the anode where they make their way through the external circuit (doing useful work such as turning a motor) and return to the cathode side of the fuel cell.

Meanwhile, on the cathode side of the fuel cell, oxygen gas ( $O_2$ ) is being forced through the catalyst where it forms two oxygen atoms. Each of these atoms has a strong negative charge. This negative charge attracts the two  $H^+$  ions through the membrane, where they combine with an oxygen atom and two of the electrons from the external circuit to form a water molecule ( $H_2O$ ).

This reaction in a single fuel cell produces only about 0.7 volt. For this voltage to become high enough to be used to move the vehicle, many separate fuel cells must be combined in series to form a fuel-cell stack (Figure 16-30).

## Fuels for the Fuel Cell

A fundamental problem with fuel cell technology concerns whether to store hydrogen or convert it from other fuels on board the vehicle. All four principal fuels that automotive manufacturers are considering (hydrogen, methanol, ethanol, and gasoline) pose some challenges.

**Hydrogen Fuel.** One solution is to store hydrogen on board the vehicle. The ability to use hydrogen directly in a fuel cell provides the highest efficiency and zero tailpipe emissions. However, hydrogen has a low energy density and boiling point, thus onboard storage requires large, heavy tanks. There are three types of hydrogen storage methods under development: compressed hydrogen, liquefied hydrogen, and binding hydrogenate to solids in metal hydrides or carbon compounds.

Compressed hydrogen offers the least expensive method for onboard storage. However, at normal CNG-operating pressures of 3500 psi (241 bar), reasonably sized, commercially available pressure tanks will provide limited range for a fuel cell vehicle (about 120 miles or

193 km). Daimler and Hyundai are now using pressure tanks that are capable of 5,000 psi (345 bar). Quantum is conducting research of high-performance hydrogen storage systems, looking at pressure tanks that are capable of up to 10,000 psi (689 bar). This capability would permit a 400-mile (644 km) driving range.

Liquefied hydrogen can be stored in large cylinders containing a hydride material (something like steel wool). Liquefied hydrogen does not require the high storage capacity as that of compressed hydrogen for the same amount of driving range. However, the very low boiling point of hydrogen requires that the tanks have excellent insulation. Maintaining the extreme cold temperature of  $-423^{\circ}\text{F}$  ( $-253^{\circ}\text{C}$ ) during refueling and storage is difficult. It is estimated that up to 25% of the liquid hydrogen may be boiled off during the refueling process. In addition, about 1% is lost per day in onboard storage. Storing liquid hydrogen on a vehicle also involves some safety concerns. As the fuel tank warms, the pressure increases and may activate the pressure relief valve. This action discharges flammable hydrogen into the atmosphere, creating a source of danger and pollution.

**Methanol.** Several automotive manufacturers are using methanol to power their fuel cells. It is believed that methanol fuel cells could bridge the gap over the next few decades while a hydrogen distribution infrastructure is being built. Using “methanolized” hydrogen as fuel has the advantage that it can be stored on the vehicle similarly to gasoline. For the reaction in the fuel cell, a **reformer** on board the vehicle produces hydrogen from the methanol fuel. A reformer is a high-temperature device that converts hydrocarbon fuels to carbon monoxide (CO) and hydrogen. To produce the hydrogen, the methanol fuel is mixed with water. When it evaporates, it is decomposed into hydrogen and carbon dioxide ( $\text{CO}_2$ ). Prior to sending the hydrogen and  $\text{CO}_2$  to the fuel cell, it is purified in additional steps.

Methanolized hydrogen contains more hydrogen atoms and has an energy density that is greater than that of liquid hydrogen. Like hydrogen, methanolized hydrogen is also independent of mineral oil. Compared with hydrogen, vehicles driven by methanol are not completely emissions-free, but they produce very little pollutants and much less  $\text{CO}_2$  than internal combustion engines.

A special type of PEM fuel cell, called the direct methanol air fuel cell (DMAFC) utilizes methanol combined with water directly as a fuel and ambient air for oxygen. This technology enables use of a liquid fuel without the need for an onboard reformer while still providing a zero-emissions system. However, current research has demonstrated that the power density is lower than for other PEM fuel cells.

**Ethanol.** Ethanol is considered less toxic than either gasoline or methanol. An ethanol system requires adding a reformer to the vehicle, similar to a methanol system. The fuel cell could use E100, E95, or E85.

**Gasoline.** Fuel cells can be driven with a special, more pure gasoline. Using reformers for onboard extraction of hydrogen from gasoline is one approach to commercialization of fuel cell vehicles since the gasoline infrastructure is already in place. However, producing hydrogen from gasoline in a vehicle system is much more difficult than producing hydrogen from methanol or ethanol. Gasoline reforming requires higher temperatures and more complex systems than the methanol or ethanol reforming. The reformation reactions occur at  $1,562^{\circ}\text{F}$  to  $1,823^{\circ}\text{F}$  ( $850^{\circ}\text{C}$  to  $995^{\circ}\text{C}$ ), making the devices slow to start and the chemistry temperamental. Thus, the drive would work less efficiently and produce more emissions. Moreover, the capabilities for cold starts would be restricted. The size of the reformer is also an issue, making it difficult to fit under the hood of a standard-sized vehicle. Furthermore, there is concern about the sulfur levels in current gasoline and CO in the reformer poisoning the fuel cell.

**Reformer.** As mentioned, some fuel cell systems may require the use of an onboard reformer to extract hydrogen from liquid fuels such as gasoline, methanol, or ethanol. Onboard reformation of a hydrocarbon fuel into hydrogen allows the use of more established infrastructures, but

adds additional weight and cost and reduces vehicle efficiency. In addition, the reformer does create some emissions.

PEM fuel cell reformers combine fuel and water to produce additional  $H_2$  and convert the CO to  $CO_2$ . The  $CO_2$  is then released to the atmosphere. Reformer technologies include steam reforming (SR), partial oxidation, and high temperature electrolytes reforming.

SR uses a catalyst to convert fuel and steam to  $H_2$ , CO, and  $CO_2$ . The CO is further reformed with steam to form more  $H_2$  and  $CO_2$ . A purification step then removes CO,  $CO_2$ , and any impurities to achieve a high hydrogen purity level (97% to 99.9%). SR of methanol is the most developed and least expensive method to produce hydrogen from a hydrocarbon fuel on a vehicle, resulting in 45% to 70% conversion efficiency.

Partial oxidation reforming is similar to steam reforming since both technologies combine fuel and steam but this process adds oxygen in an additional step. The process is less efficient than SR but the heat-releasing nature of the reaction makes it more responsive than SR to variable load. Heavier HC can be used in POX, but it has lower carbon-to-hydrogen ratios, which limits hydrogen production.

Hydrogen can also be obtained by **electrolysis** from water. Electrolysis is the splitting of water into hydrogen and oxygen. The drawback to this process is that it requires a great deal of electrical energy. Recently, the development of high-temperature electrolytes that can operate at temperatures in excess of 212°F (100°C) has shown some positive results. The benefits of high-temperature electrolytes include:

- *Improved CO tolerance.* This allows the manufacturer to reduce or remove the need for an oxidation reactor and for air-bleed. Since these requirements can be reduced, system efficiency is increased by 5% to 10%. There is also a considerable reduction in start-up time. The remaining CO will be combusted in a catalytic tail-gas burner to prevent emissions of CO.
- *Facilitated stack cooling.* This reduces the size of the radiator and reduces the fuel cell stack cooling plate requirements.
- *Humidity-independent operation.* Generally, high-temperature membranes require humidifiers and water recovery, whereas this system does not.

**Solid Oxide Fuel Cells.** Planar solid oxide fuel cells (SOFCs) operate at high temperatures of 932°F to 1,472°F (500°C to 800°C) and can use CO and  $H_2$  fuel. SOFCs have a good tolerance to fuel impurities and use ceramic as an electrolyte. BMW is currently developing an auxiliary power unit (APU) with Delphi and Global Thermoelectric using an SOFC. Currently, SOFCs use gasoline fuel and require a reformer.

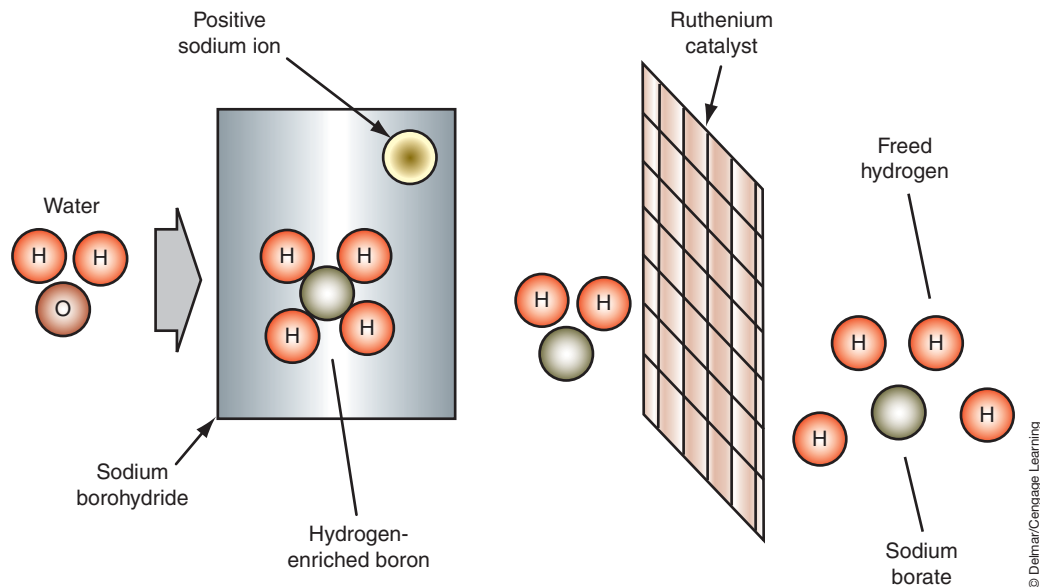
**Sodium Borohydride.** A joint venture between Daimler and Chrysler introduced a new idea in fuel technologies with a concept minivan called the Chrysler Town & Country Natrium (Latin for sodium). This research was driven by the lack of a safe, compact way to contain hydrogen. In addition, most fuel cell vehicles are not “on demand,” meaning that there is a start-up time required before the reformer can begin producing hydrogen.

A fairly simple chemical process mixes sodium borohydride ( $NaBH_4$ ) powder with water. The  $NaBH_4$  powder produces free hydrogen for the fuel cell (Figure 16-31). Unlike the fuel cell systems that use methanol or gasoline, the Natrium produces no pollution and no  $CO_2$ .

The  $NaBH_4$  powder holds more hydrogen than the most densely compressed hydrogen tank. The prototype minivan attains a top speed of 80 mph (129 km/h) and an operating range of almost 300 miles (487 km). The by-products of this process are water and sodium borate, which is basically laundry detergent. After use, the spent powder goes into a storage tank where it can be pumped out and reclaimed.

As the name implies,  $NaBH_4$  is a salt. The salt that powers this system is not ordinary table salt (sodium chloride— $NaCl$ ). Rather, it is a white salt whose molecules contain a relatively large amount of hydrogen. Through the use of a chemical catalyst, the  $NaBH_4$  reaction with

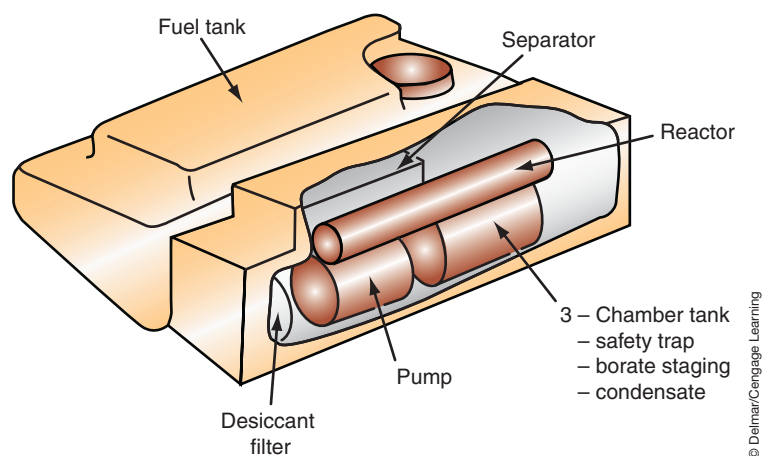
The advantage of sodium borohydride is that it can be stored easily and transported in lightweight plastic tanks at normal temperatures and pressures when dissolved in water. Also, the borate solution is not poisonous, flammable, or explosive.



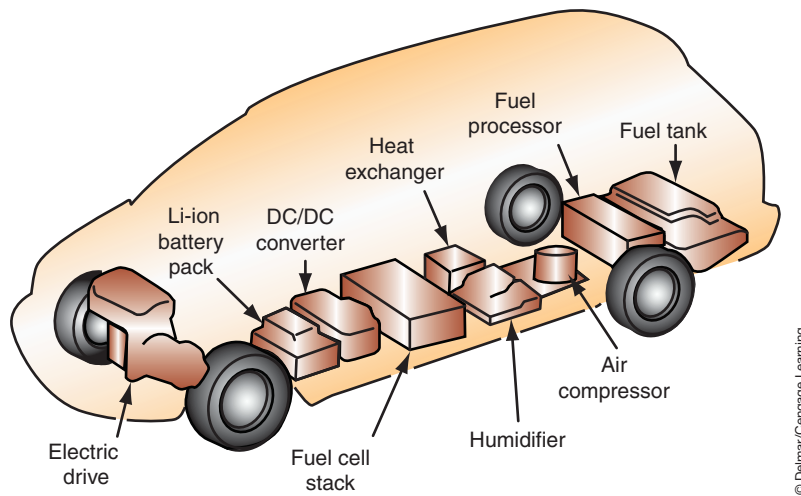
**FIGURE 16-31** Process of extracting hydrogen from sodium borohydride.

water results in elemental hydrogen. A slurry of sodium perborate ( $\text{NaBO}_2$ ) forms during this reaction as well. This compound is chemically related to borax, which is used as a bleaching agent in conventional detergents. The  $\text{NaBH}_2$  slurry is collected in a special tank and can be effectively recycled in a chemical process. In this reverse reaction, the  $\text{NaBH}_2$  is reclaimed back to  $\text{NaBH}_4$ , which can then be reused as an energy source for the fuel cells.

The catalyst system is called Hydrogen on Demand™ and was developed by Millennium Cell (Figure 16-32). When stepping on the accelerator, the minivan driver is actually “throttling” a fuel pump. The  $\text{NaBH}_4$  is pumped into the catalyst, which immediately generates hydrogen. This dynamic process slows or ceases entirely when the fuel pump is throttled or completely shut off. When the driver accelerates once more, hydrogen is immediately produced again and the fuel cells immediately generate electricity.



**FIGURE 16-32** The Hydrogen on Demand™ catalyst system is the heart of the drive train. The hydrogen required for the fuel cell to generate power is extracted from sodium borohydride in a reactor.



**FIGURE 16-33** Components of the sodium borohydride fuel cell minivan are all located between the frame rails.

An AC motor with an output of 35 kW powers the vehicle. A 55-kW lithium-ion battery serves as a storage unit for electrical energy. The battery is recharged by the fuel cell unit and by regenerative braking. If the fuel cell system should fail, the battery would be sufficient to drive the electric motor and move the vehicle. All fuel cell components are contained within the frame rail of the vehicle (Figure 16-33).

## SUMMARY

- EVs powered by an electric motor run from a battery pack.
- The HEV relies on power from the electric motor, the engine, or both.
- The hybrid vehicle can be configured as a parallel, series, or combination hybrid system.
- Regenerative braking recovers the energy used to brake by converting rotational energy into electrical energy through a system of electric motors and generators. When the brakes are applied, the motor becomes a generator by using the kinetic energy of the vehicle to store power in the battery for later use.
- To meet the electrical demands of the automobile in the future, manufacturers are presently developing 42-volt systems.
- An additional benefit that may be derived from the use of a 42-volt system is it allows manufacturers to electrify most of the inefficient mechanical and hydraulic systems that are currently used.
- There are several methods that are being used and developed for the electrical architecture of the 42-volt system. One method is a simple single 42-volt system that is very similar to the current 12-volt/14-volt system. Another method is the dual-voltage system.
- The dual-generator system uses two generators: one that operates at 42 volts, while the other operates at 14 volts.
- In the dual-stator, dual-voltage system, voltage is produced from a single alternator that has two output voltages.
- Another design uses a DC/DC converter that is configured to provide a 14-volt output from the 42-volt input.
- Arcing is perhaps the greatest challenge facing the design and use of the 42-volt system.
- One of the newest technologies to emerge from the research and development of the 42-volt system is the ISG.

## TERMS TO KNOW

Belt alternator starter (BAS)  
 DC/DC converter  
 Dual-generator system  
 Dual-stator, dual-voltage system  
 Dual-voltage system  
 Electric vehicle (EV)  
 Electrolysis



## TERMS TO KNOW

(continued)

Fuel cell

Full parallel hybrid

High voltage ECU

(HV ECU)

Hybrid electric vehicle

(HEV)

Integrated starter

generator (ISG)

Lean burn technology

Mild parallel hybrid

Parallel hybrid

Proton exchange

membrane (PEM)

Reformer

Regenerative braking

Series hybrid

Single 42-volt system

Starter generator control

module (SGCM)

Ultra capacitor

## SUMMARY

- Hybrid vehicles utilize the automatic stop (or idle stop) feature to shut off the engine whenever the vehicle is not moving or when power from the engine is not required.
- The ISG can also convert kinetic energy to storable electric energy. When the vehicle is traveling downhill and there is zero load on the engine, the wheels can transfer energy through the transmission and engine to the ISG. The ISG then sends this energy to the battery for storage and use by the electrical components of the vehicle.
- The BAS is about the same size as a conventional generator and is mounted in the same way.
- The ISG is a three-phase AC motor. At low vehicle speeds, the ISG provides power and torque to the vehicle. It also supports the engine, when the driver demands more power.
- The ISG includes a rotor and stator that is located inside the transmission bellhousing and is formed by laser-welding copper bars. The rotor is bolted to the engine crankshaft.
- Both the BAS and the ISG use the same principle to start the engine. Current flows through the stator windings it generates magnetic fields in the rotor. This will cause the rotor to turn, thus turning the crankshaft and starting the engine.
- A fuel cell-powered vehicle is basically an EV except the fuel cell produces and supplies electric power to the electric motor instead of batteries.
- Fuel cells electrochemically combine oxygen from the air with hydrogen to produce electricity.
- The most common type of fuel cell is the PEM.
- There are several methods being explored for storage of fuel for the fuel cell. These include hydrogen, methanol, ethanol, and gasoline.
- Most fuel cell systems require the use of a reformer to extract hydrogen from liquid fuels such as gasoline, methanol, or ethanol.

## REVIEW QUESTIONS

### Short-Answer Essay

1. Explain the meaning of regenerative braking.
2. Describe the basic operation of a typical hybrid vehicle.
3. Explain the difference between parallel and series hybrids.
4. Briefly describe how the proton exchange membrane (PEM) fuel cell produces electrical energy.
5. What is the purpose of the reformer?
6. Explain why increasing amperage output of a generator is not able to meet the demands of the electrical system on future vehicles.
7. Explain the advantages that can be derived from the 42-volt electrical system.
8. Describe the basics of the three common dual-voltage systems.
9. What are some of the challenges of implementing the 42-volt system?
10. Describe the basic function of the integrated starter generator system.

### Fill-in-the-Blanks

1. \_\_\_\_\_ recovers the heat energy used to brake by converting rotational energy into \_\_\_\_\_ energy through a system of electric motors and generators.
2. Fuel cells \_\_\_\_\_ combine oxygen from the air with hydrogen to produce electricity.
3. Most fuel cell systems require the use of a \_\_\_\_\_ to extract hydrogen from liquid fuels such as gasoline, methanol, or ethanol.
4. In a \_\_\_\_\_ hybrid configuration, there is a direct mechanical connection between the engine and the wheels.
5. In the \_\_\_\_\_ hybrid vehicle, there is no mechanical connection between the engine and the wheels.
6. The \_\_\_\_\_ is the negative post of the fuel cell.



*This page intentionally left blank*

## GLOSSARY

## GLOSARIO

---

Note: **Terms are highlighted in bold**, followed by **Spanish translation in color**.

**Absorbed glass mat (AGM) battery** A variation of the recombination batteries that hold their electrolyte in a moistened fiberglass matting instead of using a gel. The plates are made of high-purity lead and are tightly compressed into six cells.

**Batería de malla de fibra de vidrio absorbente (AGM, por su sigla en inglés)** Una variante de las baterías de recombinación que contienen sus electrolitos en una malla de fibra de vidrio humedecido en lugar de utilizar gel. Las placas están fabricadas con plomo de alta pureza y están bien comprimidas en seis celdas.

**Accelerometer** Generates an analog voltage in relation to the severity of deceleration forces. The accelerometer also senses the direction of impact force.

**Acelerómetro** Genera un voltaje análogo en relación a la severidad de las fuerzas de deceleración. El acelerómetro también detecta la dirección de la fuerza de un impacto.

**A circuit** A generator regulator circuit that uses an external grounded field circuit. In the A circuit, the regulator is on the ground side of the field coil.

**Circuito A** Circuito regulador del generador que utiliza un circuito inductor externo puesto a tierra. En el circuito A, el regulador se encuentra en el lado a tierra de la bobina inductora.

**Actuators** Devices that perform the actual work commanded by the computer. They can be in the form of a motor, relay, switch, or solenoid.

**Accionadores** Dispositivos que realizan el trabajo efectivo que ordena la computadora. Dichos dispositivos pueden ser un motor, un relé, un conmutador o un solenoide.

**Adaptive brake lights** A brake light system that selects different illumination levels or methods of display for the rear brake lights depending on conditions.

**Luces de freno adaptables** Un sistema de luces de freno que selecciona diferentes niveles de iluminación o métodos de visualización para las luces del freno traseras, de acuerdo con las condiciones.

**Adaptive headlight system (AHS)** Headlight system that is designed to enhance night-time safety by turning the headlight beams to follow the direction of the road as the vehicle enters a turn.

**Sistema de faros delanteros adaptables (AHS, por su sigla en inglés)** Sistema de faros diseñado para mejorar la seguridad durante la noche, ya que las luces de los faros giran para seguir la dirección del camino al tomar una curva.

**Adaptive memory** The ability of the computer system to store changing values in order to correct operating characteristics.

**Memoria adaptable** La capacidad del sistema de computación de almacenar valores cambiantes para corregir las características operativas.

**Adaptive strategy** The capacity of the computer to make corrections to the normal strategy based on input signals.

**Estrategia adaptable** La capacidad de una computadora de realizar correcciones a la estrategia normal sobre la base de las señales recibidas.

**Air bag** Inflates in a few milliseconds when the vehicle is involved in a frontal collision. A typical fully inflated air bag has a volume of 2.3 cu. ft.

**Bolsa de aire** Infla en unos milisegundos cuando un vehículo se ha involucrado en una colisión delantera. Una bolsa de aire típica tiene un volumen de 2.3 pies cúbicos al estar completamente inflada.

**Air bag module** Composed of the air bag and inflator assembly, which is packaged into a single module.

**Unidad del Airbag** Formada por el conjunto del Airbag y el inflador. Este conjunto se empaqueta en una sola unidad.

**Air bag system** Designed as a supplemental restraint that, in the case of an accident, will deploy a bag out of the steering wheel or passenger-side dash panel to provide additional protection against head and face injuries.

**Sistema de bolsa de aire** Diseñada como una restricción suplemental que, en el caso de un accidente, desplegará una bolsa del volante de dirección o del tablero lateral del pasajero para proveer la protección adicional contra los daños a la cabeza y a la cara.

**Air core gauge** Gauge design that uses the interaction of two electromagnets and the total field effect upon a permanent magnet to cause needle movement.

**Calibrador de núcleo de aire** Calibrador diseñado para utilizar la interacción de dos electroimanes y el efecto inductor total sobre un imán permanente para generar el movimiento de la aguja.

**Alternating current** Electrical current that changes direction between positive and negative.

**Corriente alterna** Corriente eléctrica que recorre un circuito ya sea en dirección positiva o negativa.

**Ambient temperature** The temperature of the outside air.

**Temperatura ambiente** Temperatura del aire ambiente.

**Ambient temperature sensor** A thermistor used to determine the ambient temperature.

**Sensor de la temperatura ambiente** Termostato que se usa para determinar la temperatura ambiente.

**American wire gauge (AWG)** System used to determine wire sizes based on the cross-sectional area of the conductor.

**Calibrador americano de alambres** Sistema utilizado para determinar el tamaño de los alambres, basado en el área transversal del conductor.

**Ammeter** A test meter used to measure current draw.

**Amperímetro** Instrumento de prueba utilizado para medir la intensidad de una corriente.

**Amortisseur winding** The name given to the bars of a squirrel cage placed around the AC motor's rotor.

**Amortisseur que enrolla** El nombre dado a las barras de una jaula de ardilla colocó alrededor del rotor del motor de C.A.

**Ampere-hour rating** Indicates the amount of steady current a battery can supply for 20 hours.

**Límite de amperio-hora** Indica la cantidad de corriente fijo que un puede proveer una batería durante 20 horas.

**Amperes** See current.

**Amperios** Véase corriente.

**Analog** A voltage signal that is infinitely variable or that can be changed within a given range.

**Señal analógica** Señal continua y variable que debe traducirse a valores numéricos discontinuos para poder ser tratada por una computadora.

**Anode** The positive charge electrode in a voltage cell.

**Ánodo** Electrodo de carga positiva de un generador de electricidad.

**Antilock brakes (ABS)** A brake system that automatically pulsates the brakes to prevent wheel lockup under panic stop and poor traction conditions.

**Frenos antibloqueo** Sistema de frenos que pulsa los frenos automáticamente para impedir el bloqueo de las ruedas en casos de emergencia y de tracción pobre.

**Antitheft device** A device or system that prevents illegal entry or driving of a vehicle. Most are designed to deter entry.

**Dispositivo a prueba de hurto** Un dispositivo o sistema que previene la entrada o conducción ilícita de un vehículo. La mayoría se diseñan para detener la entrada.

**Armature** The movable component of an electric motor, which consists of a conductor wound around a laminated iron core and is used to create a magnetic field.

**Armadura** Pieza móvil de un motor eléctrico, compuesta de un conductor devanado sobre un núcleo de hierro laminado y que se utiliza para producir un campo magnético.

**Arming sensor** A device that places an alarm system into "ready" to detect an illegal entry.

**Sensor de armado** Un dispositivo que pone "listo" un sistema de alarma para detectar una entrada ilícita.

**Aspirator** Tubular device that uses a venturi effect to draw air from the passenger compartment over the in-car sensor. Some manufacturers use a suction motor to draw the air over the sensor.

**Aspirador** Dispositivo tubular que utiliza un efecto Venturi para extraer aire del compartimiento del pasajero sobre el sensor dentro del vehículo. Algunos fabricantes utilizan un motor de succión para extraer el aire sobre el sensor.

**Asynchronous** Data that is sent on the bus network intermittently (as needed) rather than continuously.

**Asíncronos** Datos que se envían en el bus múltiple de modo intermitente (como sea necesario) en lugar de modo continuo.

**Atom** The smallest part of a chemical element that still has all the characteristics of that element.

**Átomo** Partícula más pequeña de un elemento químico que conserva las cualidades íntegras del mismo.

**Audio system** The sound system for a vehicle; can include radio, cassette player, CD player, amplifier, and speakers.

**Sistema de audio** El sistema de sonido de un vehículo; puede incluir el radio, el tocadiscos, el toca discos compactos, el amplificador, y las bocinas.

**Automatic door locks** A system that automatically locks all doors through the activation of one switch.

**Cerros de compuertas automatizados** Cerros de compuertas automatizados eléctricamente que utilizan o un solenoide o un motor reversible de imán permanente para cerrar y abrir las puertas.

**Automatic headlight dimming** An electronic feature that automatically switches the headlights from high beam to low beam under two different conditions: light from oncoming vehicles strikes the photocell-amplifier; or light from the taillights of a vehicle that is being passed strikes the photocell-amplifier.

**Reducción automática de intensidad luminosa de los faros delanteros** Característica electrónica que conmuta los faros delanteros automáticamente de luz larga a luz corta dadas las siguientes circunstancias: la luz de los vehículos que se aproximan alcanza el amplificador de fotocélula, o la luz de los faros traseros de un vehículo que se ha rebasado alcanza el amplificador de fotocélula.

**Automatic on/off with time delay** Turns on the headlights automatically when ambient light decreases to a predetermined level. Also allows the headlights to remain on for a certain amount of time after the vehicle has been turned off. This system can be used in combination with automatic dimming systems.

**Prendido/apagado automático con temporización** Prende los faros automáticamente cuando la luz ambiental se oscurece a un nivel predeterminado. También permite que los faros quedan prendidos por un tiempo determinado después de que se ha apagado el vehículo. Este sistema se puede utilizar en combinación con los sistemas de regulación de intensidad luminosa automáticos.

**Automatic temperature control (ATC)** A passenger comfort system that is capable of maintaining a preset temperature level as selected by the operator. Sensors are used to determine the present temperatures, and the system can adjust the level of heating or cooling as required by using actuators to open and close air-blend doors to achieve the desired in-vehicle temperature.

**Control automático de la temperatura (CAT)** Un sistema de comodidad para el pasajero es capaz de mantener un nivel de temperatura previamente fijo tal como lo selecciona el operador. Los sensores se utilizan para determinar las temperaturas actuales, y el sistema puede ajustar el nivel de calentamiento o enfriamiento como se requiera al usar actuadores para abrir y cerrar las compuertas de recirculación para lograr la temperatura deseada dentro del vehículo.

**Automatic traction control** A system that prevents slippage of one of the drive wheels. This is done by applying the brake at that wheel and/or decreasing the engine's power output.

**Control Automático de Tracción** Un sistema que previene el patinaje de una de las ruedas de mando. Esto se efectúa aplicando el freno en esa rueda y/o disminuyendo la salida de potencia del motor.

**Avalanche diodes** Diodes that conduct in the reverse direction when a reverse bias voltage of about 6.2 volts or higher is applied. Causes the avalanche effect to occur when the reverse electric field moves across the PN junction, causing a wave of ionization that leads to a large current.



**Diodo Zener** Diodos que hacen conducción en dirección contraria cuando se aplica velocidad invertida de transmisión de baudios de alrededor de 6.2 voltios o más. Produce el efecto Zener o de avalancha cuando el campo eléctrico invertido se mueve a cruzar la unión PN, y causa así una onda de ionización que provoca una gran corriente.

**B circuit** A generator regulator circuit that is internally grounded. In the B circuit, the voltage regulator controls the power side of the field circuit.

**Circuito B** Circuito regulador del generador puesto internamente a tierra. En el circuito B, el regulador de tensión controla el lado de potencia del circuito inductor.

**Balanced atom** An atom that has an equal number of protons and electrons.

**Átomo equilibrado** Átomo que tiene el mismo número de protones y de electrones.

**Base** The center layer of a bipolar transistor.

**Base** Capa central de un transistor bipolar.

**BAT** The terminal identifier for the conductor from the generator to the battery positive terminal.

**BAT** El terminal que identifica el conductor del generador al terminal positivo de la batería.

**Battery cables** High-current conductors that connect the battery to the vehicle's electrical system.

**Cables de batería** Conductores de alta corriente que conectan la batería al sistema eléctrico del vehículo.

**Battery cell** The active unit of a battery.

**Acumulador de batería** Componente activo de una batería.

**Battery holddowns** Brackets that secure the battery to the chassis of the vehicle.

**Portabatería** Los sostenes que fijan la batería al chasis del vehículo.

**Battery terminals** Terminals at the battery to which the positive and the negative battery cables are connected. The terminals may be posts or threaded inserts.

**Bornes de la batería** Los bornes en la batería a los cuales se conectan los cables positivos y negativos. Los terminales pueden ser postes o piezas roscadas.

**Baud rate** The measure of computer data transmission speed in bits per second.

**Razón de baud** Medida de la velocidad de la transmisión de datos de una computadora en bits por segundo.

**Belt alternator starter (BAS)** A high-voltage starter/alternator combination that uses current flow through the stator windings to generate magnetic fields in the rotor, causing the rotor to turn, thus turning the crankshaft and starting the engine magnetic fields in the rotor, the and starting the engine.

**Arrancador del alternador por faja (AAF)** Una combinación de arrancador/alternador de alto voltaje que utiliza el flujo de corriente a través del devanado estático para generar campos magnéticos en el rotor, lo que provoca que el rotor dé vueltas, haciendo girar así el cigüeñal y arrancando el motor.

**Belt tension sensor (BTS)** A strain gauge-type sensor located on the seat belt anchor of the passenger-side front seat, used to determine if an infant seat is being used.

**Sensor de la tensión de la faja (STF)** Sensor de tipo medidor de tensiones localizado en el ancla del cinturón del asiento del lado del asiento frontal del pasajero y que se usa para determinar si se usa un asiento para bebés.

**Bendix drive** A type of starter drive that uses the inertia of the spinning starter motor armature to engage the drive gear to the gears of the flywheel. This type starter drive was used on early models of vehicles and is rarely seen today.

**Acoplamiento Bendix** Un tipo del acoplamiento del motor de arranque que usa la inercia de la armadura del motor de arranque giratorio para endentar el engranaje de mando con los engranajes del volante. Este tipo de acoplamiento del motor de arranque se usaba en los modelos vehículos antiguos y se ven raramente.

**Bias voltage** Voltage applied across a diode.

**Tensión polarizadora** Tensión aplicada a través de un diodo.

**Bimetallic strip** A metal contact wiper consisting of two different types of metals. One strip will react quicker to heat than the other, causing the strip to flex in proportion to the amount of current flow.

**Banda bimetalica** Contacto deslizante de metal compuesto de dos tipos de metales distintos. Una banda reaccionará más rápido al calor que la otra, haciendo que la banda se doble en proporción con la cantidad de flujo de corriente.

**Binary code** A series of numbers represented by 1's and 0's. Any number and word can be translated into a combination of binary 1's and 0's.

**Código binario** Serie de números representados por unos y ceros. Cualquier número y palabra puede traducirse en una combinación de unos y ceros binarios.

**Bipolar** The name used for transistors because current flows through the materials of both polarities.

**Bipolar** Nombre aplicado a los transistores porque la corriente fluye por conducto de materiales de ambas polaridades.

**Bit** A binary digit.

**Bit** Dígito binario.

**Bi-xenon headlamps** HID headlamps that use a single xenon lamp to provide both the high-beam and the low-beam operations. The full light output is used to produce the high beam, while the low beam is formed by moving a shutter between the bulb and the lens.

**Faros delanteros de doble xenón** Faros de descarga de alta intensidad (HID, por su sigla en inglés) que utilizan una sola bombilla de xenón para cubrir las funciones de luces largas y luces cortas. La potencia de luz completa se utiliza para las luces largas, mientras que las luces bajas se forman moviendo un obturador entre la bombilla y el lente.

**Blend-air door actuator** An electric motor that controls the position of the blend air door, in order to supply the in-vehicle temperature the driver selected.

**Actuador de puertas por aire mezclado** Un motor eléctrico que controla la posición de las puertas por aire mezclado para proporcionar la temperatura dentro del vehículo que seleccione el conductor.

**Bluetooth** Technology that allows several modules from different manufacturers to be connected using a standardized radio transmission.



**Bluetooth** Tecnología que permite que se conecten varios módulos de diferente manufactura por medio del uso de transmisión de radio estándar.

**Brushes** Electrically conductive sliding contacts, usually made of copper and carbon.

**Escobillas** Contactos deslizantes de conducción eléctrica, por lo general hechos de cobre y de carbono.

**Bucking coil** One of the coils in a three-coil gauge. It produces a magnetic field that bucks or opposes the low-reading coil.

**Bobina compensadora** Una de las bobinas de un calibre de tres bobinas. Produce un campo magnético que es contrario o en oposición a la bobina de baja lectura.

**Buffer** A buffer cleans up a voltage signal. These are used with PM generator sensors to change the AC voltage to a digitalized signal.

**Separador** Un separador aguza una señal del tensión. Estos se usan con los sensores generadores PM para cambiar la tensión de corriente alterna a una señal digitalizado.

**Buffer circuit** Changes the AC voltage from the PM generator into a digitalized signal.

**Circuito separador** Cambia el voltaje de corriente alterna del generador PM a una señal digital.

**Bulkhead connector** A large connector that is used when many wires pass through the bulkhead or firewall.

**Conector del tabique** Un conector que se usa al pasar muchos alambres por el tabique o mamparo de encendios.

**Bus** Used in reference to data transmission since data is being transported from one place to another. The multiplex circuit is often referred to as the bus circuit.

**Colectiva** Se usa en referir a la transmisión de datos que se están transportando de un lugar a otro. El circuito multiplex suele referirse como el circuito colectivo.

**Bus (+)** The bus circuit that is most positive when the dominant bit is being transmitted.

**Bus positivo (+)** Circuito del bus que es más positivo cuando se transmite el bit predominante.

**Bus (-)** The bus circuit that is most negative when the dominant bit is being transmitted.

**Bus negativo (-)** Circuito del bus que es más negativo cuando se transmite el bit predominante.

**Bus Bar** A common electrical connection to which all of the fuses in the fuse box are attached. The bus bar is connected to battery voltage.

**Barra colectora** Conexión eléctrica común a la que se conectan todos los fusibles de la caja de fusibles. La barra colectora se conecta a la tensión de la batería.

**Buzzer** An audible warning device that is used to warn the driver of possible safety hazards.

**Zumbador** Dispositivo audible de advertencia utilizado para prevenir al conductor de posibles riesgos a la seguridad.

**Capacitance** The ability of two conducting surfaces to store voltage.

**Capacitancia** Propiedad que permite el almacenamiento de electricidad entre dos conductores aislados entre sí.

**Capacitance discharge sensor** A pressure sensor that uses a variable capacitor. As the distance between the electrodes changes, so does the capacity of the capacitor.

**Sensor de descarga de capacitancia** Un sensor de presión que utiliza un capacitor variable. A medida que cambia la distancia entre los electrodos, también lo hace la capacidad del capacitor.

**Carbon monoxide** An odorless, colorless, and toxic gas that is produced as a result of combustion.

**Monóxido de carbono** Gas inodoro, incoloro y tóxico producido como resultado de la combustión.

**Carriers** Attached to the shoulder anchor to move or carry the anchor from one end of the track to the other.

**Portadoras** Conectados al reborde de anclaje para mudar o transportar el anclaje de una extremidad del carril a la otra.

**Cartridge fuses** See maxi-fuse.

**Fusibles cartucho** Véase maxifusible.

**Cathode** Negatively charged electrode of a voltage cell.

**Cátodo** Electrodo de carga negativa de un generador de electricidad.

**Cathode ray tube** Similar to a television picture tube. It contains a cathode that emits electrons and an anode that attracts them. The screen of the tube will glow at the points that are hit by the electrons.

**Tubo de rayos catódicos** Parecidos a un tubo de pantalla de televisor. Contiene un cátodo que emite los electrones y un ánodo que los atrae. La pantalla del tubo iluminará en los puntos en donde pegan los electrones.

**Caustic** A material that has the ability to destroy or eat through something. Caustic materials are considered extremely corrosive.

**Caustico** Una materia que tiene la habilidad de destruir o carcomer algo. Las materias causticas se consideran extremadamente corrosivas.

**Cell element** The assembly of a positive and negative plate in a battery.

**Elemento de pila** La asamblea de una placa positiva y negativa en una batería.

**Central gateway (CGW)** A module on the CAN bus network that is the hub between the different networks.

**Puerta central** Un módulo de la red de bus CAN que está en el núcleo entre las diferentes redes.

**Charging system** Converts the mechanical energy of the engine into electrical energy to recharge the battery and run the electrical accessories.

**Sistema de carga** Convierte la energía mecánica del motor en energía eléctrica para recargar la batería y hacer trabajar los accesorios eléctricos.

**CHMSL** The abbreviation for center high-mounted stop light, often referred to as the third brake light.

**CHMSL** La abreviación para el faro de parada montada alto en el centro que suele referirse como el faro de freno tercero.

**Choke** An inductor in series with a circuit.

**Reactancia** Un inductor en serie con un circuito.

**Choke coil** Fine wire wound into a coil used to absorb oscillations in a switched circuit.

**Bobina de inducción** Alambre fino devanado en una bobina, utilizado para absorber oscilaciones en un circuito conmutado.

**Chrysler Collision Detection (CCD)** Chrysler's data bus network first used in 1988. Uses a twisted pair of wires to transmit data.

- Detección de colisión de Chrysler** Red del bus de datos de Chrysler que se usó primero en 1988. Utilizó un par de hilos torcidos para transmitir datos.
- Circuit** The path of electron flow consisting of the voltage source, conductors, load component, and return path to the voltage source.
- Circuito** Trayectoria del flujo de electrones, compuesto de la fuente de tensión, los conductores, el componente de carga y la trayectoria de regreso a la fuente de tensión.
- Circuit breaker** A mechanical fuse that opens the circuit when amperage is excessive. In most cases, the circuit breaker will reset when the overload is removed.
- Interruptor** Un fusible mecánico que abre el circuito cuando la intensidad de amperaje es excesiva. En la mayoría de los casos, el interruptor se reengancha al eliminarse la sobrecarga.
- Clamping diode** A diode that is connected in parallel with a coil to prevent voltage spikes from the coil from reaching other components in the circuit.
- Diodo de bloqueo** Un diodo que se conecta en paralelo con una bobina para prevenir que los impulsos de tensión lleguen a otros componentes en el circuito.
- Clock circuit** A crystal that electrically vibrates when subjected to current at certain voltage levels. As a result, the chip produces very regular series of voltage pulses.
- Circuito de reloj** Cristal que vibra electrónicamente cuando está sujeto a una corriente a ciertos niveles de tensión. Como resultado, el fragmento produce una serie sumamente regular de impulsos de tensión.
- Clockspring** A winding of electrical conducting tape enclosed within a plastic housing. The clockspring maintains continuity between the steering wheel, switches, the air bag, and the wiring harness in all steering wheel positions.
- Muelle espiral** Una bobina de cinta conductiva eléctrica encerrada en una caja de plástico. El muelle espiral mantiene la corriente continua entre el volante de dirección, los interruptores, la bolsa de aire, y el mazo de alambres en cualquier posición del volante de dirección.
- Closed circuit** A circuit that has no breaks in the path and allows current to flow.
- Circuito cerrado** Circuito de trayectoria ininterrumpida que permite un flujo continuo de corriente.
- Coil pack** A coil assembly that contains two or more coils.
- Asamblea de bobina** Una asamblea de bobinas que contiene dos bobinas o más.
- Cold cranking rating (CCA)** Rating indicates the battery's ability to deliver a specified amount of current to start an engine at low-ambient temperatures.
- Amperios de arranque en frío** Tasa indicativa de la capacidad de la batería para producir una cantidad específica de corriente para arrancar un motor a bajas temperaturas ambiente.
- Cold engine lock-out switch** Prevents blower motor operation until the air entering the passenger compartment reaches a specified temperature.
- Interruptor de cierre en motor inactivo** Previene la operación del motor del ventilador hasta que el aire que entra en el compartimiento del pasajero alcanza su temperatura específica.
- Collector** The portion of a bipolar transistor that receives the majority of current carriers.
- Dispositivo de toma de corriente** Parte del transistor bipolar que recibe la mayoría de los portadores de corriente.
- Common connector** A connector that is shared by more than one circuit and/or component.
- Conector común** Un conector que se comparte entre más de un circuito y/o componente.
- Commutator** A series of conducting segments located around one end of the armature.
- Conmutador** Serie de segmentos conductores ubicados alrededor de un extremo de la armadura.
- Component locator** A service manual that lists and describes the exact location of components on a vehicle.
- Localizador de componentes** Un manual de servicio que cataloga y describe la posición exacta de los componentes en un vehículo.
- Composite bulb** A headlight assembly that has a replaceable bulb in its housing.
- Bombilla compuesta** Una asamblea de faros cuyo cárter tiene una bombilla reemplazable.
- Composite headlights** A halogen headlight system that uses a replacement bulb.
- Faros compuestos** Un sistema de faros halógenos que usa un foco de recambio.
- Compound motor** A motor that has the characteristics of a series-wound and a shunt-wound motor.
- Motor compuesta** Un motor que tiene las características de un motor excitado en serie y uno en derivación.
- Computer** An electronic device that stores and processes data and is capable of operating other devices.
- Computadora** Dispositivo electrónico que almacena y procesa datos y que es capaz de ordenar a otros dispositivos.
- Concealed headlight** System used to help improve fuel economy and styling of the vehicle.
- Faros ocultos** Un sistema que se usa para mejorar el rendimiento del combustible y el estilo del vehículo.
- Condenser** A capacitor made from two sheets of metal foil separated by an insulator.
- Condensador** Capacitador hecho de dos láminas de metal separadas por un medio aislante.
- Conduction** Bias voltage difference between the base and the emitter has increased to the point that the transistor is switched on. In this condition, the transistor is conducting. Output current is proportional to that of the current through the base.
- Conducción** La diferencia de la tensión polarizadora entre la base y el emisor ha aumentado hasta el punto que el transistor es conectado. En estas circunstancias, el transistor está conduciendo. La corriente de salida está en proporción con la de la corriente conducida en la base.
- Conductor** A material in which electrons flow or move easily.
- Conductor** Una material en la cual los electrones circulen o se mueven fácilmente.
- Contactors** Heavy-duty relays that are connected to the positive and negative sides of the HV battery.
- Contactos** Relés para servicio pesado conectados al positivo y al negativo de la batería HV.
- Continuity** Refers to the circuit being continuous with no opens.

**Continuidad** Se refiere al circuito ininterrumpido, sin aberturas.

**Control panel assembly** Provides for driver input into the automatic temperature control microprocessor.

**Asamblea de controles** Permite la entrada del conductor al microprocesador del control de temperatura automático. La asamblea de control también se refiere como el tablero de instrumentos.

**Controller area network (CAN)** A two-wire bus network that allows the transfer of data between control modules.

**CAN (Red del área del controlador)** Red de bus de dos hilos que permite la transferencia de datos entre los módulos de control.

**Conventional theory** Electrical theory that states current flows from a positive point to a more negative point.

**Teoría convencional** Teoría de electricidad la cual enuncia que el corriente fluye desde un punto positivo a un punto más negativo.

**Cornering lights** Lamps that illuminate when the turn signals are activated. They burn steady when the turn signal switch is in a turn position, to provide additional illumination of the road in the direction of the turn.

**Faros de viraje** Los faros que iluminen cuando se prenden los indicadores de virajes. Quedan prendidos mientras que el indicador de viraje esta en una posición de viraje para proveer mayor iluminación del camino en la dirección del viraje.

**Counterelectromotive force (CEMF)** An induced voltage that opposes the source voltage.

**Fuerza contraelectromotriz** Tensión inducida en oposición a la tensión fuente.

**Courtesy lights** Lamps that illuminate the vehicle's interior when the doors are open.

**Luces interiores** Lámparas que iluminan el interior del vehículo cuando las puertas están abiertas.

**Covalent bonding** When atoms share valence electrons with other atoms.

**Enlace covalente** Cuando los átomos comparten electrones de valencia con otros átomos.

**Crash sensor** Normally open electrical switch designed to close when subjected to a predetermined amount of jolting or impact.

**Sensor de impacto** Un conmutador normalmente abierto diseñado a cerrarse al someterse a un sacudo de una fuerza determinada a un impacto.

**Cruise control** A system that allows the vehicle to maintain a preset speed with the driver's foot off the accelerator.

**Control crucero** Un sistema que permite que el vehículo mantenga una velocidad determinada sin que el pie del conductor deprime al acelerador.

**Crystal** A term used to describe a material that has a definite atom structure.

**Cristal** Término utilizado para describir un material que tiene una estructura atómica definida.

**Current** The aggregate flow of electrons through a wire. One ampere represents the movement of 6.25 billion billion electrons (or one coulomb) past one point in a conductor in one second.

**Corriente** Flujo combinado de electrones a través de un alambre. Un amperio representa el movimiento de 6,25 mil millones de mil millones de electrones (o un coulombio) que sobrepasa un punto en un conductor en un segundo.

**Cutoff** When reverse-bias voltage is applied to the base leg of the transistor. In this condition, the transistor is not conducting and no current will flow.

**Corte** Cuando se aplica tensión polarizadora inversa a la base del transistor. En estas circunstancias, el transistor no está conduciendo y no fluirá ninguna corriente.

**Cycle** Completed when the voltage has gone positive, returned to zero, gone negative, and returned to zero.

**Ciclo** Completado cuando el voltaje ha sido positivo, regresado al cero, ha sido negativo y regresado al cero.

**Darlington pair** An arrangement of transistors that amplifies current by one transistor acting as a preamplifier that creates a larger base current to the second transistor.

**Par Darlington** Conjunto de transistores que amplifica la corriente. Un transistor actúa como preamplificador y produce una corriente base más amplia para el segundo transistor.

**D'Arsonval gauge** A gauge design that uses the interaction of a permanent magnet and an electromagnet, and the total field effect to cause needle movement.

**Calibrador d'Arsonval** Calibrador diseñado para utilizar la interacción de un imán permanente y de un electroimán, y el efecto inductor total para generar el movimiento de la aguja.

**Daytime running lamps** Generally use the high-beam or low-beam headlight system at a reduced intensity to provide additional visibility of the vehicle for other drivers and pedestrians.

**Faros diurnos** Generalmente usan el sistema de faros de alta y baja intensidad en una intensidad disminuida para proporcionar el vehículo más visibilidad para los otros conductores y los peatones.

**DC/DC converter** The DC/DC converter is configured to provide a 14-V output from the high-voltage input. The 14-V output can be used to supply electrical energy to those components that do not require the high voltage.

**Convertidor continua-continua** El convertidor continua-continua está configurado para proporcionar una salida de 14 V de una entrada de alto voltaje. La salida de 14 V puede usarse para suplir energía eléctrica a aquellos componentes que no requieran de alto voltaje.

**Deep cycling** Discharging the battery completely before recharging it.

**Operación cíclica completa** La descarga completa de la batería previo al recargo.

**Delta connection** A connection that receives its name from its resemblance to the Greek letter delta ( $\Delta$ ).

**Conexión delta** Una conexión que recibe su nombre a causa de su apariencia parecida a la letra delta griega.

**Delta stator** A three-winding AC generator stator with the ends of each winding connected to each other.

**Estátor delta** Estátor generador de corriente alterna de devanado triple, con los extremos de cada devanado conectados entre sí.

**Depletion-type FET** Cuts off current flow.

**FET tipo agotamiento** Corta el flujo del corriente.

**Depressed park** A system in which the blades drop down below the lower windshield molding to hide them.

**Limpiaparabrisas guardadas** Un sistema en el cual los brazos se guardan abajo del borde inferior de la parabrisa para así esconderlos.

**Diagnostic module** Part of an electronic control system that provides self-diagnostics and/or a testing interface.

**Módulo de diagnóstico** Parte de un sistema controlado electronicamente que provee autodiagnóstico y/o una interfase de pruebas.

**Diaphragm** A thin, flexible, circular plate that is held around its outer edge by the horn housing, allowing the middle to flex.

**Diagrama** Una placa redonda flexible y delgada sostenido en el cárter del claxon por medio de su borde exterior, así permitiendo flexionar la parte central.

**Dielectric** An insulator material.

**Dieléctrico** Material aislante.

**Digital** A voltage signal is either on-off, yes-no, or high-low.

**Digital** Una señal de tensión está Encendida-Apagada, es Sí-No o Alta-Baja.

**Digital instrument clusters** Use digital and linear displays to notify the driver of monitored system conditions.

**Grupo de instrumentos digitales** Usan los indicadores digitales y lineares para notificar al conductor de las condiciones de los sistemas regulados.

**Dimmer switch** A switch in the headlight circuit that provides the means for the driver to select either high-beam or low-beam operation, and to switch between the two. The dimmer switch is connected in series within the headlight circuit and controls the current path for high and low beam.

**Conmutador reductor** Conmutador en el circuito para faros delanteros que le permite al conductor que elegir la luz larga o la luz corta, y conmutar entre las dos. El conmutador reductor se conecta en serie dentro del circuito para faros delanteros y controla la trayectoria de la corriente para la luz larga y la luz corta.

**DIN** The abbreviation for Deutsche Institut für Normung (German Institute for Standardization) and the recommended standard for European manufacturers to follow.

**DIN** La abreviatura de Deutsche Institut für Normung (Normas del Instituto Alemán) y se recomienda que los fabricantes europeos sigan estas normas.

**Diode** An electrical one-way check valve that will allow current to flow in one direction only.

**Diodo** Válvula eléctrica de retención, de una vía, que permite que la corriente fluya en una sola dirección.

**Diode rectifier bridge** A series of diodes that are used to provide a reasonably constant DC voltage to the vehicle's electrical system and battery.

**Puente rectificador de diodo** Serie de diodos utilizados para proveerles una tensión de corriente continua bastante constante al sistema eléctrico y a la batería del vehículo.

**Diode trio** Used by some manufacturers to rectify the stator of an AC generator current so that it can be used to create the magnetic field in the field coil of the rotor.

**Trio de diodos** Utilizado por algunos fabricantes para rectificar el estator de la corriente de un generador de corriente alterna y poder así utilizarlo para crear el campo magnético en la bobina inductora del rotor.

**Direct current (DC)** Electric current that flows in one direction.

**Corriente continua** Corriente eléctrica que fluye en una dirección.

**Direct drive** A situation where the drive power is the same as the power exerted by the device that is driven.

**Transmisión directa** Una situación en la cual el poder de mando es lo mismo que la potencia empleada por el dispositivo arrastrado.

**Discrete devices** Electrical components that are made separately and have wire leads for connections to an integrated circuit.

**Dispositivos discretos** Componentes eléctricos hechos uno a uno; tienen conductores de alambre para hacer conexiones a un circuito integrado.

**Discriminating sensors** Part of the air bag circuitry; these sensors are calibrated to close with speed changes that are great enough to warrant air bag deployment. These sensors are also referred to as crash sensors.

**Sensores discriminadores** Una parte del conjunto de circuitos de Airbag; estos sensores se calibran para cerrar con los cambios de la velocidad que son bastante severas para justificar el despliegue del Airbag. Estos sensores también se llaman los sensores de impacto.

**Doping** The addition of another element with three or five valence electrons to a pure semiconductor.

**Impurificación** La adición de otro elemento con tres o cinco electrones de valencia a un semiconductor puro.

**Double-filament lamp** A lamp designed to execute more than one function. It can be used in the stoplight circuit, taillight circuit, and the turn signal circuit combined.

**Lámpara con filamento doble** Lámpara diseñada para llevar a cabo más de una función. Puede utilizarse en una combinación de los circuitos de faros de freno, de faros traseros y de luces indicadoras para virajes.

**Double-start override** Prevents the starter motor from being energized if the engine is already running.

**Sobremarcha de doble marcha** Previene que se excite el motor del encendido si ya está en marcha el motor.

**Drain** The portion of a field-effect transistor that receives the holes or electrons.

**Drenador** Parte de un transistor de efecto de campo que recibe los agujeros o electrones.

**Drive coil** A hollowed field coil used in a positive-engagement starter to attract the movable pole shoe of the starter.

**Bobina de excitación** Una bobina inductora hueca empleada en un encendedor de acoplamiento directo para atraer la pieza polar móvil del encendedor.

**Drive spring** Absorbs the initial shock of engagement of the starter.

**Resorte de enganche** Absorba el choque inicial del enganche.

**Dual climate control** Provides separate temperature settings for the driver and the front-seat passenger. This system is similar to previous systems except two blend doors are used to control separate temperature settings.

**Control de clima doble** Provea la regulación de temperatura individual para el conductor y el pasajero del asiento delantero. Este sistema es parecido a los sistemas anteriores menos que los dos compuertas de mezcla se usan para controlar la regulación individual de la temperatura.

**Dual-generator system** Uses one generator that operates at 42 volts while another operates at 14 volts.



**Sistema de doble voltaje** Arquitectura que utiliza dos voltajes separados. Uno es para el sistema de 42 voltios que enciende los accesorios eléctricos que podrían requerir o beneficiarse de mayor voltaje. El resto de las cargas continúan en 14 voltios.

**Dual Range Circuits** This circuit provides for a switch in the resistance values to allow the microprocessor to more accurately measure temperatures.

**Circuitos de doble rango** Este circuito proporciona un interruptor en los valores de resistencia para permitir que el microprocesador mida las temperaturas de manera más precisa.

**Dual-stator, dual-voltage system** Dual voltage (42 volts and 14 volts) is produced from a single alternator that has two output voltages.

**Sistema de doble voltaje y doble estator** Un alternador sencillo que tiene voltajes de dos salidas y produce un doble voltaje (42 voltios y 14 voltios).

**Dual-voltage system** Architecture that uses two separate voltages. One is for the 42-volt system that powers those electrical accessories that would require or benefit from the higher voltage. The remainder of the loads remain on 14 V.

**Sistema de doble voltaje** Arquitectura que utiliza dos voltajes separados. Uno es para el sistema de 42 voltios que enciende los accesorios eléctricos que podrían requerir o beneficiarse de mayor voltaje. El resto de las cargas continúan en 14 voltios.

**Duty cycle** The percentage of on time to total cycle time.

**Ciclo de trabajo** Porcentaje del trabajo efectivo a tiempo total del ciclo.

**Dwell** The length of time, in degree of distributor shaft rotation, that there is a current flow in the primary circuit prior to firing the spark plug.

**Reposo** La cantidad del tiempo, medida por grados de rotación del eje del distribuidor, en que hay un flujo de corriente en el circuito primario antes de encender la bujía.

**Easy exit** An additional function of the memory seat that provides for easier entrance and exit of the vehicle by moving the seat all the way back and down. Some systems also move the steering wheel up and to full retract.

**Salida fácil** Una función adicional de la memoria del asiento que provee una entrada y salida más fácil del vehículo al mover el asiento hasta su posición más extrema hacia atrás y abajo. Algunos sistemas también muevan el volante de dirección hacia arriba y a su posición más alejada.

**Eddy currents** Small induced currents.

**Corriente de Foucault** Pequeñas corrientes inducidas.

**Electric defoggers** Heat the rear window to remove ice and/or condensation. Some vehicles use the same circuit to heat the outside driver's-side mirror.

**Desneblador eléctrica** Calientan la ventanilla trasera para remover el hielo y/o la condensación. Algunos vehículos usan el mismo circuito para calentar el espejo lateral del conductor.

**Electric vehicle (EV)** A vehicle that powers its motor off of a battery pack.

**Vehículo eléctrico (VE)** Vehículo que apaga su motor por medio de un paquete de baterías.

**Electrical accessories** Electrical systems or components that provide for additional safety and comfort, including safety

accessories such as the horn, windshield wipers, and windshield washers. Comfort accessories include the blower motor, electric defoggers, power mirrors, power windows, power seats, and power door locks.

**Accesorios eléctricos** Sistemas o componentes eléctricos que proporcionan seguridad y comodidad adicionales, y que incluyen accesorios de seguridad tales como el claxon, limpia brisas y parabrisas. Los accesorios de comodidad incluyen un motor de aire, desnubilizador eléctrico, espejos mecánicos, asientos mecánicos y cierre mecánico de puertas.

**Electrical load** The working device of the circuit.

**Carga eléctrica** Dispositivo de trabajo del circuito.

**Electrical symbols** Used to represent components in the wiring diagram.

**Símbolos electrónicos** Se usan para representar los componentes en un esquema de conexiones.

**Electrically Erasable PROM (EEPROM)** Memory chip that allows for electrically changing the information one bit at a time.

**Capacidad de borrado electrónico PROM** Fragmento de memoria que permite el cambio eléctrico de la información un bit a la vez.

**Electrochemical** The chemical action of two dissimilar materials in a chemical solution.

**Electroquímico** Acción química de dos materiales distintos en una solución química.

**Electrochromic mirror** Automatically adjusts to light by using forward and rearward facing photo sensors and a solid-state chip. Based on light intensity differences, the chip applies a small voltage to the silicon layer. As voltage is applied, the molecules of the layer rotate and redirect the light beams. Thus the mirror reflection appears dimmer.

**Espejo electrocrómico** Se ajusta automáticamente a la luz usando los sensores orientados hacia afrente y atrás juntos con un chip de estado sólido.

**Electrolysis** The producing of chemical changes by passing electrical current through an electrolyte. The splitting of water into hydrogen and oxygen.

**Electrólisis** La producción de los cambios químicos al pasar un corriente eléctrico por un electrolito.

**Electrolyte** A solution of 64% water and 36% sulfuric acid.

**Electrolito** Solución de un 64% de agua y un 36% de ácido sulfúrico.

**Electromagnetic gauge** Gauge that produces needle movement by magnetic forces.

**Calibrador electromagnético** Calibrador que genera el movimiento de la aguja mediante fuerzas magnéticas.

**Electromagnetic induction** The production of voltage and current within a conductor as a result of relative motion within a magnetic field.

**Inducción electromagnética** Producción de tensión y de corriente dentro de un conductor como resultado del movimiento relativo dentro de un campo magnético.

**Electromagnetic interference (EMI)** An undesirable creation of electromagnetism whenever current is switched on and off.

**Interferencia electromagnética** Fenómeno de electromagnetismo no deseable que resulta cuando se conecta y se desconecta la corriente.

**Electromagnetism** A form of magnetism that occurs when current flows through a conductor.

**Electromagnetismo** Forma de magnetismo que ocurre cuando la corriente fluye a través de un conductor.

**Electromechanical** A device that uses electricity and magnetism to cause a mechanical action.

**Electromecánico** Un dispositivo que causa una acción mecánica por medio de la electricidad y el magnetismo.

**Electromotive force (EMF)** See voltage.

**Fuerza electromotriz** Véase tensión.

**Electron** Negative-charged particles of an atom.

**Electrón** Partículas de carga negativa de un átomo.

**Electron theory** Defines electrical movement as from negative to positive.

**Teoría del electrón** Define el movimiento eléctrico como el movimiento de lo negativo a lo positivo.

**Electronic regulator** Uses solid-state circuitry to perform regulatory functions.

**Regulador electrónico** Usa los circuitos de estado sólido para llevar a cabo las funciones de regulación.

**Electronic stability control** An additional function of the antilock brake and traction control system that uses additional sensors and inputs to determine if the vehicle is actually moving in the direction intended by the driver, as indicated by steering wheel position sensors, yaw sensors, and lateral sensors. If the actual path is not the intended path, the module will apply the appropriate brake to bring the vehicle back onto the correct path.

**Mando electrónico de estabilidad** Función adicional de un sistema de antibloqueo de frenos y de control de la tracción que utiliza sensores adicionales y entradas para determinar si efectivamente se mueve el vehículo en la dirección que desea el conductor, tales como indican los sensores de posición del volante, los sensores de guiñada y los sensores laterales. Si el recorrido real no es el recorrido deseado, el módulo aplicará el freno apropiado para regresar el vehículo al recorrido correcto.

**Electrostatic field** The field that is between the two oppositely charged plates.

**Campo electrostático** Campo que se encuentra entre las placas de carga opuesta.

**Emitter** The outer layer of the transistor, which supplies the majority of current carriers.

**Emisor** Capa exterior del transistor que suministra la mayor parte de los portadores de corriente.

**Energy density** The amount of energy that is available for a given amount of space.

**Densidad de la energía** La cantidad de energía disponible en un espacio dado.

**Engine vacuum** Formed during the intake stroke of the cylinder. Engine vacuum is any pressure lower than atmospheric pressure.

**Vacío del motor** Formado durante la carrera de entrada de un cilindro. El vacío de motor es cualquier presión más baja de la presión atmosférica.

**Enhancement-type FET** Improves current flow.

**FET tipo de acrecentamiento** Mejora el flujo de corriente.

**Equivalent series load (equivalent resistance)** The total resistance of a parallel circuit, which is equivalent to the resistance of a single load in series with the voltage source.

**Carga en serie equivalente (resistencia equivalente)** Resistencia total de un circuito en paralelo, equivalente a la resistencia de una sola carga en serie con la fuente de tensión.

**Erasable PROM (EPROM)** Similar to PROM except that its contents can be erased to allow for new data to be installed. A piece of Mylar tape covers a window. If the tape is removed, the microcircuit is exposed to ultraviolet light and erases its memory.

**Capacidad de borrado PROM** Parecido al PROM, pero su contenido puede borrarse para permitir la instalación de nuevos datos. Un trozo de cinta Mylar cubre una ventana; si se remueve la cinta, el microcircuito queda expuesto a la luz ultravioleta y borra la memoria.

**EVR** Stands for external voltage regulator.

**EVR** Representa el Regulador de Voltaje Externo.

**Excitation current** Current that magnetically excites the field circuit of the AC generator.

**Corriente de excitación** Corriente que excita magnéticamente al circuito inductor del generador de corriente alterna.

**Express down** A power window feature that allows the operator to lower the window with a single press of the switch instead of having to hold the switch during window operation.

**Bajada rápida** Una función de los levantavidrios automáticos que permite que el operador baje la ventanilla oprimiendo un interruptor una sola vez en lugar de mantener el interruptor oprimido durante el funcionamiento de la ventanilla.

**Express up** A power window feature that allows the operator to raise the window with a single press of the switch instead of having to hold the switch during window operation.

**Subida rápida** Una función de los levantavidrios automáticos que permite que el operador suba la ventanilla oprimiendo un interruptor una sola vez en lugar de mantener el interruptor oprimido durante el funcionamiento de la ventanilla.

**Face shield** A clear plastic shield that protects the entire face.

**Máscara protectora** Una máscara de plástico transparente que protege la cara entera.

**Feedback** 1. Data concerning the effects of the computer's commands are fed back to the computer as an input signal. Used to determine if the desired result has been achieved. 2. A condition that can occur when electricity seeks a path of lower resistance, but the alternate path operates a component other than that intended. Feedback can be classified as a short.

**Realimentación** 1. Datos referentes a los efectos de las órdenes de la computadora se suministran a la misma como señal de entrada. La realimentación se utiliza para determinar si se ha logrado el resultado deseado. 2. Condición que puede ocurrir cuando la electricidad busca una trayectoria de menor resistencia, pero la trayectoria alterna opera otro componente que aquel deseado. La realimentación puede clasificarse como un cortocircuito.

**Fiber optics** A medium of transmitting for the transmission of light through polymethyl methacrylate plastic that keeps the light rays parallel even if there are extreme bends in the plastic.

**Transmisión por fibra óptica** Técnica de transmisión de luz por medio de un plástico de polimetacrilato de metilo que mantiene los rayos de luz paralelos aunque el plástico esté sumamente torcido.



**Field coils** Heavy copper wire wrapped around an iron core to form an electromagnet.

**Bobina del campo** El alambre grueso de cobre envuelta alrededor de un núcleo de hierro para formar un electroimán.

**Field current** The current going to the field windings of a motor or generator.

**Corriente inductora** El corriente que va a los devanados inductores de un motor o generador.

**Field-effect transistor (FET)** A unipolar transistor in which current flow is controlled by voltage in a capacitance field.

**Transistor de efecto de campo** Transistor unipolar en el cual la tensión en un campo de capacitancia controla el flujo de corriente.

**Field relay** The relay that controls the amount of current going to the field windings of a generator. This is the main output control unit for a charging system.

**Relé inductor** El relé que controla la cantidad del corriente a los devanados inductores de un generador. Es la unedad principal de potencia de salida de un sistema de carga.

**Fifth percentile female** The fifth percentile female is determined to be those who weigh less than 100 pounds (45 kg). The fifth percentile female is determined by averaging all potential occupants by size and then plotting the results on a graph.

**Quinto percentil femenino** La determinan aquellos que pesan menos de 45 kg (100 lbs. Se determina al hacer el promedio de todos los posibles ocupantes por su tamaño, y luego al trazar los resultados en una gráfica.

**Firing order** Order in which the cylinders of an engine move through the power stroke.

**Orden del encendido** El orden en el cual los cilindros de un motor cumplen la carrera de potencia.

**Fixed resistors** Have a set resistance value and are used to limit the amount of current flow in a circuit.

**Resistores fijos** Tienen un valor de resistencia fijo y se usan para limitar la cantidad de flujo del corriente en un circuito.

**Flammable** A substance that will support combustion.

**Inflamable** Una substancia que ampara la combustión.

**Flasher** Used to open and close the turn signal circuit at a set rate.

**Pulsador** Se usa para abrir y cerrar el circuito del indicador de vueltas en una velocidad predeterminada.

**Floating** The movement of voltage levels when a switch is open.

**Flotante** El movimiento de los niveles de voltaje cuando un interruptor se encuentra abierto.

**Floor jack** A portable hydraulic tool used to raise and lower a vehicle.

**Gato de pie** Herramienta hidráulica portátil utilizada para levantar y bajar un vehículo.

**Flux density** The number of flux lines per square centimeter.

**Densidad de flujo** Número de líneas de flujo por centímetro cuadrado.

**Flux lines** Magnetic lines of force.

**Líneas de flujo** Líneas de fuerza magnética.

**Forward bias** A positive voltage that is applied to the P-type material and negative voltage to the N-type material of a semiconductor.

**Polarización directa** Tensión positiva aplicada al material P y tensión negativa aplicada al material N de un semiconductor.

**Fuel cell** A battery-like component that produces current from hydrogen and aerial oxygen.

**Celda de combustible** Componente tipo batería que produce corriente del hidrógeno y del oxígeno en el aire.

**Fuel pump inertia switch** An NC switch that will open if the vehicle is involved in an impact at speeds over 5 mph or if it rolls over. When the switch opens, it turns off power to the fuel pump. This is a safety feature to prevent fuel from being pumped onto the ground or hot engine compartments if the engine dies. The switch has to be manually reset if it is triggered.

**Interruptor inercia de la bomba de combustible** Un interruptor NC que se abre si el vehículo se involucra en un choque en una velocidad que exceda 5 millas por hora o si se invierte de arriba abajo. Cuando el interruptor se abre, corta la corriente a la bomba del combustible. Este es una precaución de seguridad para prevenir que la bomba vierte el combustibel en el suelo o sobre un compartimento caliente del motor si se muere el motor. El interruptor se tiene que reenganchar a mano si se acciona.

**Full field** Maximum AC generator output.

**Campo completo** Salida máxima de un generador de corriente alterna.

**Full parallel hybrid** Uses an electric motor that is powerful enough to propel the vehicle on its own.

**Híbrido en paralelo completo** Utiliza un motor eléctrico que es lo suficientemente potente para que el vehículo se impulse por sí mismo.

**Full-wave rectification** The conversion of a complete AC voltage signal to a DC voltage signal.

**Rectificación de onda plena** La conversión de una señal completa de tensión de corriente alterna a una señal de tensión de corriente continua.

**Fuse** A replaceable circuit protection device that will melt should the current passing through it exceed its rating.

**Fusible** Dispositivo reemplazable de protección del circuito que se fundirá si la corriente que fluye por el mismo excede su valor determinado.

**Fuse block** The term used to indicate the central location of the fuses contained in a single holding fixture.

**Bloque de fusibles** El término que su usa para indicar la ubicación central de los fusibles contenidos en una fijación central.

**Fuse box** A term used to indicate the central location of the fuses contained in a single holding fixture.

**Caja de fusibles** Término utilizado para indicar la ubicación central de los fusibles contenidos en un solo elemento permanente.

**Fusible link** A wire made of meltable material with a special heat-resistant insulation. When there is an overload in the circuit, the link melts and opens the circuit.

**Cartucho de fusible** Alambre hecho de material fusible con aislamiento especial resistente al calor. Cuando ocurre una sobrecarga en el circuito, el cartucho se funde y abre el circuito.

**Gain** The ratio of amplification in an electronic device.

**Ganancia** Razón de amplificación en un dispositivo electrónico.

**Ganged** Refers to a type of switch in which all wipers of the switch move together.

**Acoplado en tándem** Se refiere a un tipo de conmutador en el cual todos los contactos deslizantes del mismo se mueven juntos.

**Gassing** The conversion of a battery's electrolyte into hydrogen and oxygen gas.

**Burbujeo** La conversión del electrolito de una batería al gas de hidrógeno y oxígeno.

**Gate** The portion of a field-effect transistor that controls the capacitive field and current flow.

**Compuerta** Parte de un transistor de efecto de campo que controla el campo capacitivo y el flujo de corriente.

**Gauge** 1. A device that displays the measurement of a monitored system by the use of a needle or pointer that moves along a calibrated scale. 2. The number that is assigned to a wire to indicate its size. The larger the number, the smaller the diameter of the conductor.

**Calibrador** 1. Dispositivo que muestra la medida de un sistema regulado por medio de una aguja o indicador que se mueve a través de una escala calibrada. 2. El número asignado a un alambre indica su tamaño. Mientras mayor sea el número, más pequeño será el diámetro del conductor.

**Gear reduction** Occurs when two different sized gears are in mesh and the driven gear rotates at a lower speed than the drive gear but with greater torque.

**Desmultiplicación** Ocurre cuando dos engranajes de distintos tamaños se engranan y el engranaje arrastrado gira con una velocidad más baja que el engranaje de mando pero con más par.

**G force** Term used to describe the measurement of the net effect of the acceleration that an object experiences and the acceleration that gravity is trying to impart to it. Basically G force is the apparent force that an object experiences due to acceleration.

**Fuerza G** Término utilizado para describir la medida del efecto neto de la aceleración que experimenta un objeto y la aceleración que la gravedad está intentando impartirle. Básicamente, la fuerza G es la fuerza aparente que un objeto experimenta debido a la aceleración.

**Grid growth** A condition where the grid grows little metallic fingers that extend through the separators and short out the plates.

**Expansión de la rejilla** Una condición en la cual la rejilla produce protuberancias metálicas que se extienden por los separadores y causan cortocircuitos en las placas.

**Grids** The frame structure of a battery that normally has connector tabs at the top. It is generally made of lead alloys.

**Rejillas** La estructura enmarcadora de una batería que normalmente tiene orejas de conexión en la parte superior. Generalmente se fabrica de aleaciones de plomo.

**Ground** The common negative connection of the electrical system. It is the point of lowest voltage.

**Tierra** Conexión negativa común del sistema eléctrico. Es el punto de tensión más baja.

**Ground side** The portion of the circuit that is from the load component to the negative side of the source.

**Lado a tierra** Parte del circuito que va del componente de carga al lado negativo de la fuente.

**Grounded circuit** An electrical defect that allows current to return to ground before it has reached the intended load component.

**Circuito puesto a tierra** Falla eléctrica que permite el regreso de corriente a tierra antes de alcanzar el componente de carga deseado.

**Ground straps** Electrical conductors that complete the return path to the battery from components that are insulated from the vehicle's chassis. In addition, ground straps help suppress EMI conduction and radiation by providing a low-resistance circuit ground path.

**Conectores de puesta a tierra** Conductores eléctricos que completan el circuito de regreso hacia la batería de los componentes que están aislados desde el chasis del vehículo. Además, los conectores de puesta a tierra ayudan a suprimir la conducción IEM y la radiación al proporcionar un recorrido de tierra del circuito de resistencia.

**Half-field current** The current going to the field windings of a motor or generator after it has passed through a resistor in series with the circuit.

**Corriente de medio campo** El corriente que va a los devanados inductores de un motor o a un generador después de que haya pasado por un resistor conectado en serie con el circuito.

**Half-wave rectification** Rectification of one-half of an AC voltage.

**Rectificación de media onda** Rectificación en la que la corriente fluye únicamente durante semiciclos alternados.

**Hall-effect switch** A sensor that operates on the principle that if a current is allowed to flow through thin conducting material being exposed to a magnetic field, another voltage is produced.

**Conmutador de efecto Hall** Sensor que funciona basado en el principio de que si se permite el flujo de corriente a través de un material conductor delgado que ha sido expuesto a un campo magnético, se produce otra tensión.

**Halogen** The term used to identify a group of chemically related nonmetallic elements. These elements include chlorine, fluorine, and iodine.

**Halógeno** Término utilizado para identificar un grupo de elementos no metálicos relacionados químicamente. Dichos elementos incluyen el cloro, el flúor y el yodo.

**Hand tools** Tools that use only the force generated from the body to operate. They multiply the force received through leverage to accomplish the work.

**Herramientas manuales** Herramientas que para funcionar sólo necesitan la fuerza generada por el cuerpo. Para llevar a cabo el trabajo, las herramientas multiplican la fuerza que reciben por medio de la palancada.

**Hazardous material** Materials that can cause illness, injury, or death or pollute water, air, or land.

**Material peligroso** Las materias que puedan causar la enfermedad, los daños, la muerte o que puedan contaminar el agua, el aire o la tierra.

**Headlight leveling system (HLS)** Uses front lighting assemblies with a leveling actuator motor to allow the headlights to be adjusted into different vertical positions to compensate for headlight position that can occur when the vehicle is loaded.

**Sistema de nivelación de los faros (SNF)** Utiliza el ensamblaje de los faros frontales con un motor accionador de nivelación para permitir el ajuste de los faros en diferentes posiciones verticales para compensar la posición que el faro pudiera tomar si se carga el vehículo.

**Head-up display (HUD)** Displays images onto the inside of the windshield so the driver can see them without having to take his eyes off the road.

**Presentación en pantalla (HUD)** Proyecta las imágenes en la parte interior de la parabrisa para que el conductor las pueda ver sin tener que tomar su atención de la pista.

**Heated windshield system** A specially designed windshield that allows current flow through the glass without interfering with the driver's vision; it is capable of melting ice and frost from the windshield three to five times faster than conventional defroster systems.

**Sistema de parabrisas térmico** Parabrisas especialmente diseñado para permitir el flujo de la corriente a través del vidrio sin interferir con la visión del conductor; está capacitado para derretir el hielo y la escarcha que haya en el parabrisa de 3 a 5 veces más rápido que los sistemas convencionales anticongelantes.

**Heater core flow valve** Shuts off the coolant flow through the heater core when the A/C system is in the max air mode.

**Válvula del flujo térmico del núcleo** Cierra el flujo del enfriador a través del núcleo del calentador cuando el sistema AC está en el mando de aire máximo.

**Heat sink** An object that absorbs and dissipates heat from another object.

**Dispersador térmico** Objeto que absorbe y disipa el calor de otro objeto.

**H-gate** A set of four transistors that can reverse current.

**Compuerta H** Juego de cuatro transistores que pueden invertir la corriente.

**HID** High-intensity discharge; a lighting system that uses an arc across electrodes instead of a filament.

**HID** Descarga de Alta Intensidad; un sistema de iluminación que utiliza un arco por dos electrodos en vez de un filamento.

**High-intensity discharge (HID)** Uses an inert gas to amplify the light produced by arcing across two electrodes.

**Descarga de alta intensidad (HID)** Usa un gas inerte para amplificar la luz producida al conectar dos electrodos con una arca.

**High-reading coil** Position at a 90-degree angle to the low-reading and bucking coils.

**Bobina de lectura de alta tensión** Posiciona en un ángulo a las bobinas de lectura de tensión baja y las bobinas compensadoras.

**High-side drivers** Control the output device by varying the positive (12-volt) side.

**Impulsores del lado de alto potencial** Controlan el dispositivo de salida en variar el lado positivo (12 voltios).

**High-voltage ECU (HV ECU)** See starter generator control module (SGCM).

**UCE de alto voltaje (UCE AV)** Vea el módulo de control del generador de arranque (MCGA)

**Hoist** A lift that is used to raise the entire vehicle.

**Elevador** Montacargas utilizado para elevar el vehículo en su totalidad.

**Holddowns** Secure the battery to reduce vibration and to prevent tipping.

**Portador** Aseguran la batería para disminuir la vibración y prevenir que se vierte.

**Hold-in winding** A winding that holds the plunger of a solenoid in place after it moves to engage the starter drive.

**Devanado de retención** Un devanado que posiciona el núcleo móvil de un solenoide después de que mueva para accionar el acoplamiento del motor de arranque.

**Hole** The absence of an electron in an element's atom. These holes are said to be positively charged since they have a tendency to attract free electrons into the hole.

**Agujero** Ausencia de un electrón en el átomo de un elemento. Se dice que dichos agujeros tienen una carga positiva puesto que tienden a atraer electrones libres hacia el agujero.

**Horn** A device that produces an audible warning signal.

**Claxon** Un dispositivo que produce una señal de advertencia audible.

**Hybrid air bag** Modules use compressed gas to fill the air bag instead of burning a chemical to produce gas.

**Bolsa de aire híbrido** Los módulos usan el gas comprimido para llenar la bolsa de aire en vez de quemar una química para producir un gas.

**Hybrid battery** A battery that combines the advantages of low maintenance and maintenance-free batteries.

**Batería híbrida** Una batería que combina las ventajas de las baterías de bajo mantenimiento y de no mantenimiento.

**Hybrid electric vehicle (HEV)** System that has two different power sources. In most hybrid vehicles (HEV), the power sources are a small displacement gasoline or diesel engine and an electric motor.

**Vehículo eléctrico híbrido (VEH)** Sistema con dos diferentes fuentes de potencia. En la mayoría de los vehículos híbridos (VEH), las fuentes de potencia son un motor de diesel o de gasolina de desplazamiento menor y un motor eléctrico.

**Hydrometer** A test instrument used to check the specific gravity of the electrolyte to determine the battery's state of charge.

**Hidrómetro** Instrumento de prueba utilizado para verificar la gravedad específica del electrolito y así determinar el estado de la carga de la batería.

**Igniter** A combustible device that converts electric energy into thermal energy to ignite the inflator propellant in an air bag system.

**Ignitor** Un dispositivo combustible que convierte la energía eléctrica a la energía térmica para encender el propelente inflador en un sistema Airbag.

**Ignition coil** A step-up transformer that builds up the low-battery voltage of approximately 12.6 volts to a voltage that is high enough to jump across the spark plug gap and ignite the air-fuel mixture.

**Bobina de encendido** Transformador multiplicador que sube el bajo voltaje de la batería de aproximadamente 12.6 voltios a uno lo suficientemente alto para brincar sobre el hueco de la bujía y encender la mezcla de aire y combustible.

**Ignition switch** The power distribution point for most of the vehicle's primary electrical systems.

**Selector de encendido** Punto de distribución de potencia para la mayoría de los sistemas eléctricos principales del vehículo.

**Ignition system** Responsible for delivering properly timed high-voltage surges to the spark plugs.

**Sistema de encendido** Es responsable de llevar subidas de alto voltaje reguladas apropiadamente a las bujías.

**Ignition timing** Refers to the precise time a spark is sent to the cylinder relative to the piston position.

**Tiempo del encendido** Refiere al tiempo preciso en el que una chispa es mandada al cilindro en relación a la posición del pistón.



**Illuminated entry systems** Turn on the courtesy lights before the doors are opened.

**Sistemas de entrada iluminada** Enciendan las luces de cortesía antes de que se abren las puertas.

**Immobilizer system** Designed to provide protection against unauthorized vehicle use by disabling the engine if an invalid key is used to start the vehicle or if an attempt to hot-wire the ignition system is made.

**Sistema inmovilizante** Diseñado para proporcionar protección contra el uso no autorizado del vehículo al desactivar el motor si una llave que no es válida se utiliza para encender el vehículo o para intentar “hacerle el puente” al vehículo.

**Incandescence** The process of changing energy forms to produce light.

**Incandescencia** Proceso a través del cual se cambian las formas de energía para producir luz.

**Induced voltage** Voltage that is produced in a conductor as a result of relative motion within magnetic flux lines.

**Tensión inducida** Tensión producida en un conductor como resultado del movimiento relativo dentro de líneas de flujo magnético.

**Induction** The magnetic process of producing a current flow in a wire without any actual contact to the wire. To induce 1 volt, 100 million magnetic lines of force must be cut per second.

**Inducción** Proceso magnético a través del cual se produce un flujo de corriente en un alambre sin contacto real alguno con el alambre. Para inducir 1 voltio, deben producirse 100 millones de líneas de fuerza magnética por segundo.

**Induction motor** An AC motor that generates its own rotor current as the rotor cuts the magnetic flux lines of the stator field.

**Motor de inducción** Un motor de CA que genera su propia corriente de rotor a medida que el rotor corta las líneas de flujo magnético del campo del estator.

**Inductive reactance** The result of current flowing through a conductor and the resultant magnetic field around the conductor that opposes the normal flow of current.

**Reactancia inductiva** El resultado de un corriente que circule por un conductor y que resulta en un campo magnético alrededor del conductor que opone el flujo normal del corriente.

**Inductive reluctance** A statement of a material's ability to strengthen the magnetic field around it.

**Reluctancia a la inducción** Una indicación de la habilidad de una materia en reenforzar el campo que la rodea.

**Inertia** The tendency of an object that is at rest and an object that is in motion to stay in motion.

**Inercia** La tendencia de un objeto que esta en descanso quedarse en descanso y un objeto en movimiento de quedarse en movimiento.

**Inertia engagement** A type of starter motor that uses rotating inertia to engage the drive pinion with the engine flywheel.

**Conexión por inercia** Tipo de motor de arranque que utiliza inercia giratoria para engranar el piñon de mando con el volante de la máquina.

**Inertia lock retractors** Use a pendulum mechanism to lock the belt tightly during sudden movement.

**Retractores de cierre tipo inercia** Usan un mecanismo de péndulo para enclavar fuertemente la cinta durante un movimiento repentino.

**Inflatable knee blocker (IKB)** A small air bag that deploys simultaneously with the driver's side airbag to provide upper-leg protection and positioning of the driver.

**Bloqueante inflable de la rodilla (BIR)** Pequeña bolsa de aire que se despliega simultáneamente con la bolsa de aire lateral del conductor para proporcionar protección a la parte superior de las piernas y el posicionamiento del conductor.

**Infrared temperature sensor** A sensor that measures the surface temperature of an object or person by measuring the intensity of the energy given off by an object.

**Sensor infrarrojo para la temperatura** Sensor que mide la temperatura de la superficie de un objeto o persona al medir la intensidad de la energía que desprende un objeto.

**Installation diagrams** Provide a more accurate duplication of where the wire harness, connectors, and components are found on the vehicle.

**Esquemas de instalación** Proveen una duplicación más precisa de donde se encuentran el cableado preformado, los conectores, y los componentes en el vehículo.

**Instrument panel dimming** System in which the headlight switch dimming control is used as an input to the computer instead of having direct control of the illumination lights.

**Reducción luminosa del tablero de instrumentos** Un sistema en el cual el control del interruptor de luminosidad se usa como una entrada a la computadora en vez de tener control directo al luminosidad.

**Instrument voltage regulator (IVR)** Provides a constant voltage to the gauge, regardless of the voltage output of the charging system.

**Instrumento regulador de tensión** Le provee tensión constante al calibrador, sin importar cual sea la salida de tensión del sistema de carga.

**Insulated side** The portion of the circuit from the positive side of the source to the load component.

**Lado aislado** Parte del circuito que va del lado positivo de la fuente al componente de carga.

**Insulator** A material that does not allow electrons to flow easily through it.

**Aislador** Una material que no permite circular fácilmente los electrones.

**Integrated circuit (IC chip)** A complex circuit of thousands of transistors, diodes, resistors, capacitors, and other electronic devices that are formed onto a small silicon chip. As many as 30,000 transistors can be placed on a chip that is 1/4 inch (6.35 mm) square.

**Circuito integrado (Fragmento CI)** Circuito complejo de miles de transistores, diodos, resistores, condensadores, y otros dispositivos electrónicos formados en un fragmento pequeño de silicio. En un fragmento de 1/4 de pulgada (6,35 mm) cuadrada, pueden colocarse hasta 30.000 transistores.

**Integrated starter generator (ISG)** A combination starter generator in one unit that attaches directly to the crankshaft to allow for the automatic stop/start function of an HEV. It can also convert kinetic energy to DC voltage when the vehicle is traveling downhill and there is zero load.

**Generador de arranque integrado** Combinación de generador de arranque en una unidad que se adhiere directamente al cigüeñal para permitir la función automática de encendido y apagado de un VEH. También puede convertir la energía cinemática a voltaje de corriente continua cuando el vehículo va de bajada y no lleva carga.

**Intelligent windshield wipers** A wiper system that uses a monitoring system to detect if water is present on the windshield and that automatically turns on the wiper system.

**Limpiaparabrisas inteligente** Sistema de limpiadores que utiliza un sistema de monitoreo para detectar si hay agua en el parabrisas, y esto hace que automáticamente se encienda el sistema de los limpiadores.

**Interface** Used to protect the computer from excessive voltage levels and to translate input and output signals.

**Interfase** Utilizada para proteger la computadora de niveles excesivos de tensión y traducir señales de entrada y salida.

**International Standards Organization (ISO)** Symbols used to represent the gauge function.

**Organización Internacional de Normas (ISO)** Los símbolos que se usan para representar la función del indicador.

**In-vehicle sensor** The in-vehicle sensor contains a temperature-sensing NTC thermistor to measure the average temperature inside the vehicle.

**Sensor en el vehículo** El sensor dentro del vehículo contiene un termostato de coeficiente de temperatura negativo (CTN) para percibir la temperatura que mide la temperatura promedio dentro del vehículo.

**Ion** An atom or group of atoms that has an electrical charge.

**Ion** Átomo o grupo de átomos que poseen una carga eléctrica.

**Ionize** To electrically charge.

**Ionizar** Cargar eléctricamente.

**ISO** An abbreviation for International Standards Organizations.

**ISO** Una abreviación de las Organizaciones de Normas Internacionales.

**ISO 14230-4** A bus data protocol that uses a single-wire bidirectional data line to communicate between the scan tool and the nodes. This data bus is only used for diagnostics and maintains the ISO 9141 protocol with a baud rate of 10.4 Kb/s.

**ISO 14230-4** Protocolo de un bus de datos que utiliza una línea de datos en dos direcciones en un hilo sencillo para comunicarse entre el instrumento de exploración y los nodos. Este bus de datos se utiliza solamente para diagnósticos y mantiene el protocolo de ISO 9141 con una velocidad de transmisión de baudios de 10.4 Kb/s.

**ISO 9141-2** A class B system with a baud rate of 10.4 Kb/s used only for diagnostic purposes between the nodes on the data bus and an OBD II standardized scan tool.

**ISO 9141-2** Sistema B de clase A con una velocidad de transmisión de baudios de 10.4 Kb/s que se utiliza sólo con un propósito de diagnóstico entre los nodos en el bus de datos y un instrumento de exploración estandarizado del sistema de diagnóstico a bordo II o DAB II.

**ISO K** An adoption of the ISO 9141-2 protocol that allows for bidirectional communication on a single wire. Vehicles that use the ISO-K bus require that the scan tool provide the bias voltage to power up the system.

**ISO K** La adopción del protocolo del ISO 9141-2 es que permite la comunicación en dos direcciones en un hilo sencillo. Los vehículos que utilizan el bus de ISO-K requieren que el instrumento de exploración proporcione la tensión de polarización para hacer funcionar el sistema.

**ISO relays** Conform to the specifications of the International Standards Organization (ISO) for common size and terminal patterns.

**Relés ISO** Conforman a las especificaciones de la Organización Internacional de Normas (ISO) en tamaño normal y conformidades de terminales.

**J1850** The bus system that is the class B standard for OBD II. The J1850 standard allows for two different versions based on baud rate. The first supports a baud rate of 41.6 Kb/s that is transmitted by a pulse width modulated (PWM) signal over a twisted pair of wires. The second protocol supports a baud rate of 10.4 Kb/s average that is transmitted by a variable pulse width (VPW) data bus over a single wire.

**J1850** El sistema de bus que es el estándar de clase B para el sistema de diagnóstico a bordo II o DAB II. El estándar J1850 permite dos diferentes versiones que se basan en la velocidad de transmisión de baudios. El primero respalda una velocidad de transmisión de baudios de 41.6 Kb/s que transmite una señal de modulación de duración de impulsos (MDI o PWM) mediante un par torcido de hilos. El segundo protocolo respalda una velocidad de transmisión de baudios de 10.4 Kb/s promedio que transmite un bus de datos de anchura variada entre impulsos (AVI o VPW) mediante un hilo sencillo.

**Jack stands** Support devices used to hold the vehicle off the floor after it has been raised by the floor jack.

**Soportes de gato** Dispositivos de soporte utilizados para sostener el vehículo sobre el suelo después de haber sido levantado con el gato de pie.

**Keyless entry** A lock system that allows for locking and unlocking of a vehicle with a touch keypad instead of a key.

**Entrada sin llave** Un sistema de cerradura que permite cerrar y abrir un vehículo por medio de un teclado en vez de utilizar una llave.

**Keyless start system** System that allows the vehicle to be started without the use of an ignition key.

**Sistema de encendido sin llave** Sistema que permite que el vehículo se arranque sin usar una llave de encendido.

**K-line** One circuit of the ISO 9141-2 data bus that is used for transmitting data from the module to the scan tool. The scan tool provides the bias voltage onto this circuit and the module pulls the voltage low to transmit its data.

**Línea K** Un circuito del bus de datos ISO 9141-2 que se utiliza para transmitir datos de un módulo a un instrumento de exploración. El instrumento de exploración proporciona la tensión de polarización sobre este circuito, y el módulo baja el voltaje para transmitir sus datos.

**Laminated construction** Construction of the armature from individual stampings.

**Construcción laminada** La armadura esta construida de un matizado individual.

**Lamination** The process of constructing something with layers of materials that are firmly connected.

**Laminación** El proceso de construir algo de capas de materiales unidas con mucha fuerza.

**Lamp** A device that produces light as a result of current flow through a filament. The filament is enclosed within a glass envelope and is a type of resistance wire that is generally made from tungsten.

**Lámpara** Dispositivo que produce luz como resultado del flujo de corriente a través de un filamento. El filamento es un tipo de alambre de resistencia hecho por lo general de tungsteno, que es encerrado dentro de una bombilla.

**Lamp outage module** A current-measuring sensor that contains a set of resistors, wired in series with the power supply to the headlights, taillights, and stop lights. If the sensor indicates that a lamp is burned out, the module will alert the driver.

**Unidad de avería de la lámpara** Sensor para medir corriente que incluye un juego de resistores, alambreado en serie con la fuente de alimentación a los faros delanteros, traseros y a las luces de freno. Si el sensor indica que se ha apagado una lámpara, la unidad le avisará al conductor.

**Leading edge** The edges of the rotating blade that enter the switch in a Hall-effect switch.

**Borde anterior** Los bordes de la ala giratorio que entran al interruptor en un interruptor efecto Hall.

**Lean burn technology** Uses lean air-fuel ratios to increase fuel efficiency.

**Tecnología de quema limpia** Determina las relaciones aire-combustible limpios para aumentar la eficacia del combustible.

**Light-emitting diode (LED)** A gallium-arsenide diode that converts the energy developed when holes and electrons collide during normal diode operation into light.

**Diodo emisor de luz** Diodo semiconductor de galio y arseniuro que convierte en luz la energía producida por la colisión de agujeros y electrones durante el funcionamiento normal del diodo.

**Lighting system** Electrical system that consists of all of the lights used on the vehicle, including headlights, front and rear park lights, front and rear turn signals, side marker lights, daytime running lights, cornering lights, brake lights, back-up lights, instrument cluster backlighting, and interior lighting.

**Sistema de iluminación** Sistema eléctrico que consta de todas las luces que usa el vehículo, incluyendo los faros, las luces frontales y traseras de estacionamiento, las luces intermitentes frontales y traseras, luces de posición, luces de marcha diurna, luces de esquina, luces de freno, luces de marcha atrás, iluminación trasera de tablero de controles e iluminación interior.

**Limit switch** A switch used to open a circuit when a predetermined value is reached. Limit switches are normally responsive to a mechanical movement or temperature changes.

**Disyuntor de seguridad** Un conmutador que se emplea para abrir un circuito al alcanzar un valor predeterminado. Los disyuntores de seguridad suelen ser responsivos a un movimiento mecánico o a los cambios de temperatura.

**Linearity** Refers to the sensor signal being as constantly proportional to the measured value as possible. It is an expression of the sensor's accuracy.

**Linealidad** Significa que la variación del valor de una magnitud es lo más proporcional posible a la variación del valor de otra magnitud. Expresa la precisión del sensor.

**Liquid crystal display (LCD)** A display that sandwiches electrodes and polarized fluid between layers of glass. When voltage is applied to the electrodes, the light slots of the fluid are rearranged to allow light to pass through.

**Visualizador de cristal líquido** Visualizador digital que consta de dos láminas de vidrio selladas, entre las cuales se encuentran los electrodos y el fluido polarizado. Cuando se aplica tensión a los electrodos, se rompe la disposición de las moléculas para permitir la formación de caracteres visibles.

**L-line** One circuit of the ISO 9141-2 data bus that is used by the module to receive data from the scan tool. The module provides the bias onto this circuit and the scan tool pulls the voltage low to communicate.

**Línea L** Un circuito del bus de datos del ISO 9141-2 que utiliza un módulo que recibe datos de un instrumento de exploración. El módulo proporciona la tensión sobre este circuito y el instrumento de exploración baja el voltaje para comunicarse.

**Load device** The component that performs some form of work.

**Dispositivo de carga** El componente que lleva a cabo alguna forma de trabajo.

**Local interconnect network (LIN)** A bus network that was developed to supplement the CAN bus system. The term *local interconnect* refers to all of the modules in the LIN network being located within a limited area.

**LIN (Red local de interconexiones)** Una red de bus que se desarrolló para complementar el sistema de bus CAN. El término "interconexión local" se refiere a todos los módulos en la red de LIN que se encuentran dentro de un área.

**Logic gates** Electronic circuits that act as gates to output voltage signals depending on different combinations of input signals.

**Compuertas lógicas** Circuitos electrónicos que gobiernan señales de tensión de salida, dependiendo de las diferentes combinaciones de señales de entrada.

**Look-up tables** The part of a microprocessor's memory that indicates how a system should perform in the form of calibrations and specifications.

**Tablas de referencia** La parte de la memoria de una microprocesadora que indica como debe ejecutar las calibraciones y las especificaciones la sistema.

**Low-reading coil** Wound together with the bucking coil but in the opposite direction.

**Bobina de lectura de baja tensión** Envueltas juntas con la bobina compensadora pero en una dirección opuesta.

**Low side drivers** Used to complete the path to ground to turn on an actuator.

**Impulsor del lado a tierra** Usados para completar el circuito a tierra para activar un actuador.

**LUX** The International System unit of measurement of the intensity of light. It is equal to the illumination of a surface one meter away from a single candle (one lumen per square meter).

**LUX (lumen por metro cuadrado)** Unidad del sistema internacional de medida de la intensidad de la luz. Es igual a la iluminación de una superficie a un metro de distancia de una vela sencilla (un lumen por metro cuadrado).

**Magnetically coupled linear sensors** Sensor that can be used to measure movement by use of a moveable magnet, a resistor card, and a magnetically sensitive comb. Changes in the location of the magnet on the card provide a variable output.

**Sensores lineales acoplados magnéticamente** Sensor que se puede utilizar para medir el movimiento mediante el uso de un imán móvil, una tarjeta de resistor y un peine sensible al magnetismo. Los cambios en la ubicación del imán en la tarjeta proporcionan información variable.

**Magnetic field** The area surrounding a magnet where energy is exerted due to the atoms aligning in the material.



**Campo magnético** Espacio que rodea un imán donde se emplea la energía debido a la alineación de los átomos en el material.

**Magnetic flux density** The concentration of the magnetic lines of force.

**Densidad de flujo magnético** Número de líneas de fuerza magnética.

**Magnetic pulse generator** Sensor that uses the principle of magnetic induction to produce a voltage signal. Magnetic pulse generators are commonly used to send data to the computer concerning the speed of the monitored component.

**Generador de impulsos magnéticos** Sensor que funciona según el principio de inducción magnética para producir una señal de tensión. Los generadores de impulsos magnéticos se utilizan comúnmente para transmitir datos a la computadora relacionados a la velocidad del componente regulado.

**Magnetism** An energy form resulting from atoms aligning within certain materials, giving the materials the ability to attract other metals.

**Magnetismo** Forma de energía que resulta de la alineación de átomos dentro de ciertos materiales y que le da a éstos la capacidad de atraer otros metales.

**Magneto-resistive (MR) sensors** Speed detection sensor consisting of a permanent magnet and an integrated signal conditioning circuit to change resistance due to the relationship of the tone wheel and magnetic field surrounding the sensor. The change in resistance results in a digital reading of current levels by the control module.

**Sensores magneto-resistivos (MR)** Sensor de detección de velocidad que está compuesto por un imán permanente y un circuito de acondicionamiento de señales integradas para cambiar la resistencia debido a la relación entre la rueda de virado y el campo magnético que rodea al sensor. El cambio en la resistencia tiene como resultado una lectura digital de los niveles actuales por parte del módulo de control.

**Maintenance-free battery** A battery that has no provision for the addition of water to the cells. The battery is sealed.

**Sin mantención** Que no tiene provisión para añadir el agua a la células. Es una batería sellada.

**Master module** Controller on the network that translates messages between different network systems.

**Instancia maestra** Controlador o entidad única, dentro de una red distribuida, que traduce los mensajes entre los diferentes sistemas de la red.

**Material expanders** Fillers that can be used in place of the active materials in a battery. They are used to keep the cost of manufacturing low.

**Expansores de materias** Los rellenos que se pueden usar en vez de las materiales activas de una batería. Se emplean para mantener bajos los costos de la fabricación.

**Matrix** A rectangular array of grids.

**Matriz** Red lógica en una rejilla de forma rectangular.

**Maxi-fuse** A circuit protection device that looks similar to a blade-type fuse except that it is larger and has a higher amperage capacity. Maxi-fuses are used because they are less likely to cause an underhood fire when there is an overload in the circuit. If the fusible link burned in two, it is possible that the "hot" side of the fuse could come into contact with the vehicle frame and the wire could catch on fire.

**Maxifusible** Dispositivo de protección del circuito parecido a un fusible de tipo de cuchilla, pero más grande y con mayor capacidad de amperaje. Se utilizan maxifusibles porque existen menos probabilidades de que ocasionen un incendio debajo de la capota cuando ocurra una sobrecarga en el circuito. Si el cartucho de fusible se quemase en dos partes, es posible que el lado "cargado" del fusible entre en contacto con el armazón del vehículo y que el alambre se encienda.

**Media-Oriented System Transport (MOST)** A data bus system based on standards established by a cooperative effort between automobile manufacturers, suppliers, and software programmers that resulted in a data system specifically designed for the data transmission of media-oriented data. MOST uses fiber optics to transmit data at a rate up to 25 megabits per second.

**MOST** Sistema de bus de datos basado en estándares establecidos por un esfuerzo cooperativo entre los fabricantes de vehículos, los proveedores y los programadores de software que resultó en un sistema de datos específicamente diseñado para la transmisión de datos informativos. MOST utiliza fibras ópticas para transmitir datos a una velocidad de 25 megabits por segundo (25Mb/s).

**Memory effect** The battery failing to fully charge because it "remembers" its previous charge level. This results in a low-battery charge due to a battery that is not completely discharged before it is recharged.

**Efecto memoria** Fallas en la carga completa de la batería debido a que "recuerda" su nivel de carga previo. En consecuencia, se produce una baja carga de la batería ya que ésta no está completamente descargada antes de la recarga.

**Memory seats** Power seats that can be programmed to return or adjust to a point designated by the driver.

**Asientos con memoria** Los asientos automáticos que se pueden programar a regresar o ajustarse a un punto indicado por el conductor.

**Metri-pack connector** Special wire connectors used in some computer circuits. They seal the wire terminals from the atmosphere, thereby preventing corrosion and other damage.

**Conector metri-pack** Los conectores de alambres especiales que se emplean en algunos circuitos de computadoras. Impermealizan los bornes de los alambres, así previniendo la corrosión y otros daños.

**Microprocessor** The brains of the computer where most calculations take place.

**To Come** El cerebro de la computadora en donde se realizan la mayoría de los cálculos.

**Mild parallel hybrid** Uses an electric motor that is large enough to provide regenerative braking, instant engine startup, and a boost to the combustion engine.

**Híbrido de medio paralelo** Utiliza un motor eléctrico que es lo suficientemente grande para proveer freno regenerativo, encendido instantáneo del motor y un aumento a la combustión del motor.

**Mode door actuator** An electric motor that is linked to the mode door to supply airflow to the floor ducts, A/C panel ducts, or defrost ducts.

**Actuador de mando puerta** Motor eléctrico que está unido al mando puerta para suministrar flujo de aire a los conductos del piso, los conductos del panel de corriente alterna o a los conductos de descongelamiento.

**Momentary contact** A switch type that operates only when held in position.

**Contacto momentáneo** Tipo de conmutador que funciona solamente cuando se mantiene en su posición.

**MSDS (Material Data Safety Sheet)** A fact sheet of hazardous material.

**MSDS** Una joja de información de materials tóxicos.

**Multistage air bags** Hybrid air bags that use two squibs to control the rate of inflation.

**Bolsas de aire de etapas múltiples** Las bolsas de aire híbridas que usan dos petardos para controlar la velocidad de la inflación.

**Multiplexer** An electronic switch that switches between the different audio sources.

**Multiplexor** Interruptor electrónico que se usa para hacer cambios entre las diferentes fuentes de audio.

**Multiplexing** A means of transmitting information between computers. It is a system in which electrical signals are transmitted by a peripheral serial bus instead of conventional wires, allowing several devices to share signals on a common conductor.

**Multiplexaje** Medio de transmitir información entre computadoras. Es un sistema en el cual las señales eléctricas son transmitidas por una colectora periférica en serie en vez de por líneas convencionales. Esto permite que varios dispositivos compartan señales en un conductor común.

**Mutual induction** An induction of voltage in an adjacent coil by changing current in a primary coil.

**Inducción mutua** Una inducción de la tensión en una bobina adyacente que se efectúa al cambiar la tensión en una bobina primaria.

**MUX** Common acronym for multiplexing.

**MUX** Una sigla común del proceso de multiplex.

**Navigational systems** Use satellites to direct the drivers to a desired destinations.

**Sistema de navegación** Usa los satélites para dirigir el conductor a la destinación deseada.

**Negative logic** Defines the most negative voltage as a logical 1 in the binary code.

**Lógica negativa** Define la tensión más negativa como un 1 lógico en el código binario.

**Negative temperature coefficient (NTC) thermistors** Thermistors that reduce their resistance as the temperature increases.

**Termistores con coeficiente negativo de temperatura** Termistores que disminuyen su resistencia según aumenta la temperatura.

**Nematic** Describes a fluid that is a liquid crystal with a threadlike form. It has light slots that can be rearranged by applying small amounts of voltage.

**Nemático** Describe un fluido que es un cristal líquido con una forma de filamento. Tiene aberturas de luz que se pueden reorganizar por medio de la aplicación de pequeñas cantidades de voltaje.

**Neon lights** A light that contains a colorless, odorless inert gas called neon. These lamps are discharge lamps.

**Luces de neón** Una luz que contiene un gas inerte sin color, inodoro llamado neón. Estas lámparas son lámparas de descarga.

**Network** Incorporating the vehicle's electrical systems together through computers so information gathered by one system can be used by another.

**En red** Incorporar los sistemas eléctricos del vehículo mediante el uso de computadoras para que la información que obtenga un sistema pueda usarla otro sistema.

**Neutral atom** See balanced atom.

**Átomo neutro** Véase átomo equilibrado.

**Neutral junction** The center connection to which the common ends of a Y-type stator winding are connected.

**Empalme neutro** Conexión central a la cual se conectan los extremos comunes de un devanado del estátor de tipo Y.

**Neutral safety switch** A switch used to prevent the starting of an engine unless the transmission is in PARK or NEUTRAL.

**Disyuntor de seguridad en neutral** Un conmutador que se emplea para prevenir que arranque un motor al menos de que la transmisión esté en posición PARK o Neutral.

**Neutrons** Particles of an atom that have no charge.

**Neutrones** Partículas de un átomo desprovistas de carga.

**Node** A computer that is connected to a data bus network and capable of sending or receiving messages.

**Nodo** Computadora conectada a una red de bus de datos y con capacidad de mandar o recibir mensajes.

**Nonvolatile** RAM memory that will retain its memory if battery voltage is disconnected. NVRAM is a combination of RAM and EEPROM into the same chip. During normal operation, data is written to and read from the RAM portion of the chip. If the power is removed from the chip, or at programmed timed intervals, the data is transferred from RAM to the EEPROM portion of the chip. When the power is restored to the chip, the EEPROM will write the data back to the RAM.

**Memoria de acceso aleatorio no volátil [NV RAM]** Memoria de acceso aleatorio (RAM) que retiene su memoria si se desconecta la carga de la batería. La NV RAM es una combinación de RAM y EEPROM en el mismo fragmento. Durante el funcionamiento normal, los datos se escriben en y se leen de la parte RAM del fragmento. Si se remueve la alimentación del fragmento, o si se remueve ésta a intervalos programados, se transfieren los datos de la RAM a la parte del EEPROM del fragmento. Cuando se restaura la alimentación en el fragmento, el EEPROM volverá a escribir los datos en la RAM.

**Normally closed (NC) switch** A switch designation denoting that the contacts are closed until acted upon by an outside force.

**Conmutador normalmente cerrado** Nombre aplicado a un conmutador cuyos contactos permanecerán cerrados hasta que sean accionados por una fuerza exterior.

**Normally open (NO) switch** A switch designation denoting that the contacts are open until acted upon by an outside force.

**Conmutador normalmente abierto** Nombre aplicado a un conmutador cuyos contactos permanecerán abiertos hasta que sean accionados por una fuerza exterior.

**N-type material** When there are free electrons, the material is called an N-type material. The N means negative and indicates that it is the negative side of the circuit that pushes electrons through the semiconductor and the positive side that attracts the free electrons.

**Material tipo N** Al material se le llama material tipo N cuando hay electrones libres. La N significa negativo e indica que el lado negativo del circuito empuja los electrones a través del semiconductor y el lado positivo atrae los electrones libres.

**Nucleus** The core of an atom that contains the protons and neutrons.

**Núcleo** Parte central de un átomo que contiene los protones y los neutrones.

**Occupant classification systems** A mandated requirement to reduce the risk of injuries resulting from air bag deployment by determining the weight classification of the front-seat passenger.

**Sistemas de clasificación de los ocupantes** Mandato para reducir el riesgo de daños que resulten del desarrollo de la bolsa de aire al determinar la clasificación del peso del pasajero del asiento de enfrente.

**Occupational safety glasses** Eye protection that is designed with special high-impact lens and frames, and provides for side protection.

**Gafas de protección para el trabajo** Gafas diseñadas con cristales y monturas especiales resistentes y provistas de protección lateral.

**OCS service kit** Special kit that consists of the seat foam, the bladder, the pressure sensor, the occupant classification module (OCM), and the wiring.

**Kit de servicio SCO** Kit especial que consiste en hule-espuma del asiento, el depósito, el sensor de presión, el módulo de clasificación del ocupante (MCO) y el alambrado.

**OCS validation test** A test that confirms that the system can properly classify the occupant.

**Prueba de revalidación del SCO** Prueba que confirma que el sistema puede clasificar apropiadamente al ocupante.

**Odometer** A mechanical counter in the speedometer unit indicating total miles accumulated on the vehicle.

**Odómetro** Aparato mecánico en la unidad del velocímetro con el que se cuentan las millas totales recorridas por el vehículo.

**Ohm** Unit of measure for resistance. One ohm is the resistance of a conductor such that a constant current of 1 ampere in it produces a voltage of 1 volt between its ends.

**Ohmio** Unidad de resistencia eléctrica. Un ohmio es la resistencia de un conductor si una corriente constante de 1 amperio en el conductor produce una tensión de 1 voltio entre los dos extremos.

**Ohmmeter** A test meter used to measure resistance and continuity in a circuit.

**Ohmiómetro** Instrumento de prueba utilizado para medir la resistencia y la continuidad en un circuito.

**Ohm's law** Defines the relationship between current, voltage, and resistance.

**Ley de Ohm** Define la relación entre la corriente, la tensión y la resistencia.

**Open circuit** A term used to indicate that current flow is stopped. By opening the circuit, the path for electron flow is broken.

**Circuito abierto** Interrupción en el circuito eléctrico que causa que pare el flujo de corriente.

**Optical horn** A name Chrysler uses to describe their "flash-to-pass" headlamp system.

**Claxon óptico** Un nombre que usa Chrysler para describir su sistema de faros "relampaguea para rebasar."

**Oscillator** Creates a rapid back-and-forth movement of voltage.

**Oscilador** Crea un movimiento de oscilación rápido de voltaje.

**Overload** Excess current flow in a circuit.

**Sobrecarga** Flujo de corriente superior a la que tiene asignada un circuito.

**Overrunning clutch** A starter drive that uses a roller clutch to transmit torque in one direction only and freewheels in the other direction.

**Embrague de sobremarcha** Una asamblea de embrague en un acoplamiento del motor de arranque que se emplea para prevenir que el volante del motor dé vueltas al armazón del motor de arranque.

**Oversteer** The tendency of the back of the vehicle to turn on the vehicle's center of gravity and come around the front of the vehicle.

**Tener la dirección muy sensible** Tendencia de la parte trasera de un vehículo de dar vuelta en el centro de gravedad del vehículo y de doblar al frente del vehículo.

**Oxygen sensor** A voltage generating sensor that measures the amount of oxygen present in an engine's exhaust.

**Sensor de oxígeno** Un sensor generador de tensión que mide la cantidad del oxígeno presente en el gas de escape de un motor.

**Parallel circuit** A circuit that provides two or more paths for electricity to flow.

**Circuito en paralelo** Circuito que provee dos o más trayectorias para que circule la electricidad.

**Parallel hybrid** A hybrid vehicle configuration that has a direct mechanical connection between the engine and the wheels. Both the engine and the electric motor can turn the transmission at the same time.

**Híbrido en paralelo completo** Utiliza un motor eléctrico que es lo suficientemente potente para que el vehículo se impulse por sí mismo.

**Parasitic loads** Electrical loads that are still present when the ignition switch is in the OFF position.

**Cargas parásitas** Cargas eléctricas que todavía se encuentran presente cuando el botón conmutador de encendido está en la posición OFF.

**Park contacts** Located inside the motor assembly and supply current to the motor after the wiper control switch has been turned to the park position. This allows the motor to continue operating until the wipers have reached their PARK position.

**Contactos de Park** Ubicado dentro de la asamblea del motor y proveen el corriente al motor después de que el interruptor de control de la limpiaparabrisa se ha puesto en la posición de estacionamiento. Esto permite que el motor continua operando hasta que los brazos de la limpiaparabrisas hayan llegado a su posición de estacionamiento.

**Park switch** Contact points located inside the wiper motor assembly that supply current to the motor after the wiper control switch has been turned to the PARK position. This allows the motor to continue operating until the wipers have reached their PARK position.

**Conmutador PARK** Puntos de contacto ubicados dentro del conjunto del motor del frotador que le suministran corriente al motor después de que el conmutador para el control de los frotadores haya sido colocado en la posición PARK. Esto permite que el motor continúe su funcionamiento hasta que los frotadores hayan alcanzado la posición original.

**Pass key** A specially designed vehicle key with a coded resistance value. The term pass is derived from Personal Automotive Security System.



**Llave maestra** Una llave vehicular de diseño especial que tiene un valor de resistencia codificado. El termino pass se derive de las palabras Personal Automotive Security System (sistema personal de seguridad automotriz).

**Passive restraints** A passenger restraint system that automatically operates to confine the movement of a vehicle's passengers.

**Correas pasivas** Un sistema de resguardo del pasajero que opera automaticamente para limitar el movimiento de los pasajeros en el vehículo.

**Passive suspension systems** Use fixed spring rates and shock valving.

**Sistemas pasivos de suspensión** Utilizan elasticidad de muelle constante y dotación con válvulas amortiguadoras.

**Peak reverse voltage (PRV)** Indicates the maximum reverse-bias voltage that may be applied to a diode without causing junction breakdown.

**Voltaje inverso pico (PRV, por su sigla en inglés)** Indica el voltaje de polarización inversa máximo que se puede aplicar a un diodo sin causar una avería a un empalme.

**Permanent magnet gear reduction (PMGR)** A starter that uses four or six permanent magnet field assemblies in place of field coils.

**Reducción de engranaje de imán permanente (PMGR)** Un arrancador que usa cuatro o seis ensamblajes permanentes de campo magnético en vez de las bobinas de campo.

**Permeability** Term used to indicate the magnetic conductivity of a substance compared with the conductivity of air. The greater the permeability, the greater the magnetic conductivity and the easier a substance can be magnetized.

**Permeabilidad** Término utilizado para indicar la aptitud de una sustancia en relación con la del aire, de dar paso a las líneas de fuerza magnética. Mientras mayor sea la permeabilidad, mayor será la conductividad magnética y más fácilmente se comunicará a un cuerpo propiedades magnéticas.

**Photo diode** Allows current to flow in the opposite direction of a standard diode when it receives a specific amount of light.

**Fotodiodo** Permite que fluye el corriente en la dirección opuesta de él de un diodo normal al recibir una cantidad específica de luz.

**Photocell** A variable resistor that uses light to change resistance.

**Fotocélula** Resistor variable que utiliza luz para cambiar la resistencia.

**Phototransistor** A transistor that is sensitive to light.

**Fototransistor** Transistor sensible a la luz.

**Photovoltaic diodes** Diodes capable of producing a voltage when exposed to radiant energy.

**Diodos fotovoltaicos** Diodos capaces de generar una tensión cuando se encuentran expuestos a la energía de radiación.

**Pickup coil** The stationary component of the magnetic pulse generator consisting of a weak permanent magnet that has fine wire wound around it. As the timing disc rotates in front of it, the changes of magnetic lines of force generate a small voltage signal in the coil.

**Bobina captadora** Componente fijo del generador de impulsos magnéticos compuesta de un imán permanente débil devanado con alambre fino. Mientras gira el disco sincronizador enfrente de él, los cambios de las líneas de fuerza magnética generan una pequeña señal de tensión en la bobina.

**Piconets** Small transmission cells that assist in the organization of data.

**Picoredes** Pequeñas células de transmisión que ayudan a organizar los datos.

**Piezoelectric device** A voltage generator with a resistor connected in series that is used to measure fluid and air pressures.

**Dispositivo piezoeléctrico** un generador de voltaje con un resistor conectado en series que se utiliza para medir las presiones de fluido y aire.

**Piezoelectricity** Voltage produced by the application of pressure to certain crystals.

**Piezoelectricidad** Generación de polarización eléctrica en ciertos cristales a consecuencia de la aplicación de tensiones mecánicas.

**Piezoresistive device** Similar to a piezoelectric except they operate like a variable resistor. Its resistance value changes as the pressure applied to the crystal changes.

**Dispositivo piezoresistivo** Similar a uno piezoeléctrico excepto porque operan como un resistor variable. Su valor de resistencia cambia a medida que lo hace la presión que se aplica al cristal.

**Piezoresistive sensor** A sensor that is sensitive to pressure changes.

**Sensor piezoresistivo** Sensor susceptible a los cambios de presión.

**Ping (or denotation)** A knocking sound that occurs as two flame fronts collide.

**Golpeteo (detonación)** Un ruido de impacto que ocurre cuando hay colisión entre dos bordes térmicos.

**Pinion factor** A calculation using the final drive ratio and the tire circumference to obtain accurate vehicle speed signals.

**Factor de piñón** Una calculación que usa la relación de impulso final y la circunferencia de la llanta para obtener unas señales precisad de la velocidad del vehículo.

**Pinion gear** A small gear; typically refers to the drive gear of a starter drive assembly or the small drive gear in a differential assembly.

**Engranaje de piñón** Un engranaje pequeño; típicamente se refiere al engranaje de arranque de una asamblea de motor de arranque o al engranaje de mando pequeño de la asamblea del diferencial.

**Plate straps** Metal connectors used to connect the positive or negative plates in a battery.

**Abrazaderas de la placa** Los conectores metálicos que sirven para conectar las placas positivas o negativas de una batería.

**Plates** The basic structure of a battery cell; each cell has at least one positive plate and one negative plate.

**Placas** La estructura básica de una celula de batería; cada celula tiene al menos una placa positiva y una placa negativa.

**P-material** Silicon or germanium that is doped with boron or gallium to create a shortage of electrons.

**Material-P** Boro o galio añadidos al silicio o al germanio para crear una insuficiencia de electrones.

**PMGR** An abbreviation for permanent magnet gear reduction.

**PMGR** Una abreviación de desmultiplicación del engranaje del imán permanente.

**Pneumatic tools** Power tools that are powered by compressed air.

**Herramientas neumáticas** Herramientas mecánicas accionadas por aire comprimido.

**PN junction** The point at which two opposite kinds of semiconductor materials are joined together.

**Unión pn** Zona de unión en la que se conectan dos tipos opuestos de materiales semiconductores.

**Polarizers** Glass sheets that make light waves vibrate in only one direction. This converts light into polarized light.

**Polarizadores** Las láminas de vidrio que hacen vibrar las ondas de luz en un sólo sentido. Esto convierte la luz en luz polarizada.

**Polarizing** The process of light polarization or of setting one end of a field as a positive or negative point.

**Polarizadora** El proceso de polarización de la luz o de establecer un lado de un campo como un punto positivo o negativo.

**Pole** The number of input circuits.

**Poste** El número de los circuitos de entrada.

**Pole shoes** The components of an electric motor that are made of high-magnetic permeability material to help concentrate and direct the lines of force in the field assembly.

**Expansión polar** Componentes de un motor eléctrico hechos de material magnético de gran permeabilidad para ayudar a concentrar y dirigir las líneas de fuerza en el conjunto inductor.

**Positive engagement starter** A type of starter that uses the magnetic field strength of a field winding to engage the starter drive into the flywheel.

**Acoplamiento de arranque positivo** Un tipo de arrancador que utiliza la fuerza del campo magnético del devanado inductor para accionar el acoplamiento del arrancador en el volante.

**Positive plate** The plate connected to the positive battery terminal.

**Placa positiva** La placa conectada al terminal positivo de la batería.

**Positive temperature coefficient (PTC) thermistors** Thermistors that increase their resistance as the temperature increases.

**Termistores con coeficiente positivo de temperatura** Termistores que aumentan su resistencia según aumenta la temperatura.

**Potential** The ability to do something; typically voltage is referred to as the potential. If you have voltage, you have the potential for electricity.

**Potencial** La capacidad de efectuar el trabajo; típicamente se refiere a la tensión como el potencial. Si tiene tensión, tiene la potencial para la electricidad.

**Potentiometer** A variable resistor that acts as a circuit divider to provide accurate voltage drop readings proportional to movement.

**Potenciómetro** Resistor variable que actúa como un divisor de circuito para obtener lecturas de pérdidas de tensión precisas en proporción con el movimiento.

**Potentiometer** A voltage divider that provides a variable DC voltage reading to the computer. The potentiometer usually consists of a wire-wound resistor with a moveable center wiper.

**Potenciómetro** Un divisor de voltaje que proporciona una lectura de voltaje de CC variable a la computadora. El potenciómetro, por lo general, está compuesto por un resistor envuelto en alambre, con un contacto deslizante de centro móvil.

**Potentiometric pressure sensor** Sensor used to measure pressure by use of a Bourdon tube, a capsule, or bellows to move a wiper arm on a resistive element. The movement of the wiper across the resistive element will record a different voltage reading.

**Sensor de presión potenciométrica** Sensor que se utiliza para medir la presión mediante un tubo Bourdon, una cápsula o un tubo flexible ondulado para mover el brazo de un contacto deslizante en un elemento resistivo. El movimiento del contacto deslizante contra el elemento resistivo registrará una lectura de voltaje diferente.

**Power** The rate of doing electrical work.

**Potencia** La tasa de habilidad de hacer el trabajo eléctrico.

**Power door locks** Electric power door locks use either a solenoid or a permanent magnet reversible motor to lock and unlock the door.

**Cerradura mecánica de puertas** Las cerraduras electro-mecánicas de puertas utilizan o un solenoide o un motor reversible de imanes permanentes para abrir y cerrar la puerta.

**Power formula** A formula used to calculate the amount of electrical power a component uses. The formula is  $P = I \times E$ , where P stands for power (measured in watts), I stands for current, and E stands for voltage.

**Formula de potencia** Una formula que se emplea para calcular la cantidad de potencia eléctrica utilizada por un componente. La formula es  $P = I \times E$ , en el que el P quiere decir potencia (medida en wats), I representa el corriente y el E representa la tensión.

**Power mirrors** Outside mirrors that are electrically positioned from the inside of the driver's compartment.

**Especjos eléctricos** Los espejos exteriores que se ajusten eléctricamente desde el interior del compartimento del conductor.

**Power tools** Tools that use forces other than those generated from the body. They can use compressed air, electricity, or hydraulic pressure to generate and multiply force.

**Herramientas mecánicas** Herramientas que utilizan fuerzas distintas a las generadas por el cuerpo. Dichas fuerzas pueden ser el aire comprimido, la electricidad, o la presión hidráulica para generar y multiplicar la fuerza.

**Power windows** Windows that are raised and lowered by use of electrical motors.

**Ventanillas eléctricas** Las ventanillas que se suban y se bajan por medio de los motores eléctricos.

**Pressure control solenoid** A solenoid used to control the pressure of a fluid, commonly found in electronically controlled transmissions.

**Solenoide de control de la presión** Un solenoide que controla la presión de un fluido, suele encontrarse en las transmisiones controladas electrónicamente.

**Pretensioners** Used to tighten the seat belt and shoulder harness around the occupant during an accident severe enough to deploy the air bag. Pretensioners can be used on all seat belt assemblies in the vehicle.

**Pretensadores** Se usan para apretar la cinta de seguridad y el arnés del cuerpo alrededor del ocupante durante un accidente bastante severo como para activar la bolsa de aire. Los pretensadores se pueden usar en cualquier asamblea de cinta de seguridad del vehículo.

**Primary circuit** All the components that carry low voltage through the system.

**Circuito primario** Todos los componentes que llevan un voltaje bajo dentro del sistema.

**Primary coil winding** The second set of winding in the ignition coil. The primary winds will have about 200 turns to create a magnetic field to induce voltage into the secondary winding.

**Devanado primario** El grupo segundo de devanados en la bobina del encendido. Los devanados primarios tendrán unos 200 vueltas para crear un campo magnético para inducir el voltaje al devanado secundario.

**Primary wiring** Conductors that carry low voltage and current. The insulation of primary wires is usually thin.

**Hilos primarios** Hilos conductores de tensión y corriente bajas. El aislamiento de hilos primarios es normalmente delgado.

**Printed circuit** Made of thin phenolic or fiberglass board with copper deposited on it to create current paths. These are used to simplify the wiring of circuits.

**Circuito impreso** Un circuito hecho de un tablero de fenólico delgado o de fibra de vidrio el cual tiene depósitos del cobre para crear los trayectorios para el corriente. Estos se emplean para simplificar el cableado de los circuitos.

**Prism lens** A light lens designed with crystal-like patterns, which distort, slant, direct, or color the light that passes through it.

**Lente prismático** Un lente de luz con diseños cristalinos que distorsionan, inclinan, dirigen o coloran la luz que lo atraviesa.

**Prisms** Redirect the light beam and create a broad, flat beam.

**Prismas** Dirigen un rayo de luz y crean un rayo ancho y plano.

**Program** A set of instructions that the computer must follow to achieve desired results.

**Programa** Conjunto de instrucciones que la computadora debe seguir para lograr los resultados deseados.

**Program number** Represents the amount of heating or cooling required to obtain the temperature set by the driver.

**Número de programa** Representa la cantidad de calefacción o enfriamiento requerido para obtener la temperatura indicado por el conductor.

**Programmable Communication Interface (PCI)** A single wire, bidirectional communication bus where each module supplies its own bias voltage and has its own termination resistors. As a message is sent, a variable pulse width modulation (VPWM) voltage between 0 and 7.75 volts is used to represent the 1 and 0 bits.

**Interfaz de comunicación programable (PCI)** Bus de comunicación en dos direcciones en un hilo sencillo en donde cada módulo proporciona su propia velocidad de transmisión de baudios y tiene sus propias resistencias de unión. Mientras se envía un mensaje, un voltaje de anchura variada entre impulsos entre 0 y 7.75 voltios se utiliza para representar los bits 1 y 0.

**Programmer** Controls the blower speed, air mix doors, and vacuum motors of the SATC system. Depending on manufacturer, they are also called servo assemblies.

**Programador** Controla la velocidad del ventilador, las puertas de mezcla de aire y los motores de vacío de un sistema SATC. Según el fabricante, también se llaman ensamblajes servo.

**PROM (programmable read only memory)** Memory chip that contains specific data that pertains to the exact vehicle in which the computer is installed. This information may be used to inform the CPU of the accessories that are equipped on the vehicle.

**PROM (memoria de sólo lectura programable)** Fragmento de memoria que contiene datos específicos referentes al vehículo particular en el que se instala la computadora. Esta información puede utilizarse para informar a la UCP sobre los accesorios de los cuales el vehículo está dotado.

**Protection device** Circuit protector that is designed to “turn off” the system that it protects. This is done by creating an open to prevent a complete circuit.

**Dispositivo de protección** Protector de circuito diseñado para “desconectar” el sistema al que provee protección. Esto se hace abriendo el circuito para impedir un circuito completo.

**Protocol** A language used by computers to communicate with each other over a data bus.

**Protocolo** Lenguaje que se utiliza en computadoras para comunicarse entre sí sobre un mando de bus.

**Proton** Positively charged particles contained in the nucleus of an atom.

**Protón** Partículas con carga positiva que se encuentran en el núcleo de todo átomo.

**Proton exchange membrane (PEM)** Impedes the oxyhydrogen gas reaction in a fuel cell by ensuring that only protons (H<sup>+</sup>), and not elemental hydrogen molecules (H<sub>2</sub>), react with the oxygen.

**Membrana de intercambio de protones (MIP)** Impide la reacción de gas de oxígeno-hidrógeno en una célula de combustible al asegurar que sólo los protones reaccionen con el oxígeno y no las moléculas de hidrógeno elemental.

**Prove-out circuit** A function of the ignition switch that completes the warning light circuit to ground through the ignition switch when it is in the START position. The warning light will be on during engine cranking to indicate to the driver that the bulb is working properly.

**Circuito de prueba** Función del botón conmutador de encendido que completa el circuito de la luz de aviso para que se ponga a tierra a través del botón conmutador de encendido cuando éste se encuentra en la posición START. La luz de aviso se encenderá durante el arranque del motor para avisarle al conductor que la bombilla funciona correctamente.

**Pull-down circuit** Closes the switch to ground.

**Circuito de bajada** Cierra el interruptor a tierra.

**Pull-down resistor** A current limiting resistor used to assure a proper low-voltage reading by preventing float when the switch is open.

**Resistor de bajada** Un resistor que limita la corriente y que se utiliza para garantizar una lectura de voltaje bajo adecuada al evitar la flotación cuando el interruptor se encuentra abierto.

**Pull-in windings** An electrical coil internal to a solenoid that is energized to create a magnetic field used to move the solenoid plunger to the engaged position.

**Devanados de puesta en trabajo** Una bobina eléctrica que es íntegra a un solenoide que se excita para crear un campo magnético que sirve para mover el relé de solenoide a la posición de engranaje.

**Pull-up circuit** Closes the switch to voltage.

**Circuito de subida** Cierra el interruptor al voltaje.

**Pull-up resistor** A current-limiting resistor that is used to assure the proper high-voltage reading of a voltage sense circuit by connecting the voltage sense circuit to an electrical potential that can be removed when the switch is closed.



**Resistor de subida** Un resistor que limita la corriente y que se utiliza para garantizar una lectura de voltaje alto adecuada de un circuito de sensores de voltaje al conectar el circuito de sensores de voltaje a un potencial eléctrico que se puede quitar cuando el interruptor se encuentra cerrado.

**Pulse width** The length of time in milliseconds that an actuator is energized.

**Duración de impulsos** Espacio de tiempo en milisegundos en el que se excita un accionador.

**Pulse-width modulation** On/off cycling of a component. The period of time for each cycle does not change; only the amount of on time in each cycle changes.

**Modulación de duración de impulsos** Modulación de impulsos de un componente. El espacio de tiempo de cada ciclo no varía; lo que varía es la cantidad de trabajo efectivo de cada ciclo.

**Radial grid** A type of battery grid that has its patterns branching out from a common center.

**Rejilla radial** Un tipo de rejilla de batería cuyos diseños extienden de un centro común.

**Radio choke** Absorbs voltage spikes and prevents static in the vehicle's radio.

**Impedancia del radio** Absorba los impulsos de la tensión y previene la presencia del estático en el radio del vehículo.

**Radio frequency interference (RFI)** Radio and television interference caused by electromagnetic energy.

**Interferencia de frecuencia radioeléctrica** Interferencia en la radio y en la televisión producida por energía electromagnética.

**RAM (random access memory)** Stores temporary information that can be read from or written to by the CPU. RAM can be designed as volatile or nonvolatile.

**RAM (memoria de acceso aleatorio)** Almacena datos temporales que la UCP puede leer o escribir. La RAM puede ser volátil o no volátil.

**Ratio** A mathematical relationship between two or more things.

**Razón** Una relación matemática entre dos cosas o más.

**Reactivity** A statement of how easily a substance can cause or be a part of a chemical.

**Reactividad** Una indicación de cuán fácil una sustancia puede causar o ser parte de una química.

**Recirc/air inlet door actuator** An electric motor that is linked to the recirculation door to provide either outside air or in-vehicle air into the A/C heater case.

**Actuador de la compuerta de entrada de recirculación del aire** Motor eléctrico que está unido a una compuerta de recirculación para proporcionar ya sea aire de fuera o que provenga del vehículo, dentro de la caja del calentón de corriente alterna.

**Recombination battery** A type of battery that is sometimes called a dry-cell battery because it does not use a liquid electrolyte solution.

**Batería de recombinación** Un tipo de batería que a veces se llama una pila seca porque no requiere una solución líquida de electrolita.

**Rectification** The converting of AC current to DC current.

**Rectificación** Proceso a través del cual la corriente alterna es transformada en una corriente continua.

**Reflectors** A device whose surface reflects or radiates light.

**Reflectores** Un dispositivo cuyo superficie refleja o irradia la luz.

**Reformer** A high-temperature device that converts hydrocarbon fuels to CO and H<sub>2</sub>.

**Reformador** Dispositivo de alta temperatura que convierte los combustibles de hidrocarburo a monóxido de carbono CO y a H<sub>2</sub>.

**Regenerative braking** Braking energy is turned back into electricity instead of heat.

**Frenado regenerativo** La energía de frenado se convierte nuevamente en electricidad en lugar de calor.

**Relay** A device that uses low current to control a high-current circuit. Low current is used to energize the electromagnetic coil, while high current is able to pass over the relay contacts.

**Relé** Dispositivo que utiliza corriente baja para controlar un circuito de corriente alta. La corriente baja se utiliza para excitar la bobina electromagnética, mientras que la corriente alta puede transmitirse a través de los contactos del relé.

**Reluctance** A term used to indicate a material's resistance to the passage of flux lines.

**Reluctancia** Término utilizado para señalar la resistencia ofrecida por un circuito al paso del flujo magnético.

**Reserve-capacity rating** An indicator, in minutes, of how long the vehicle can be driven, with the headlights on, if the charging system should fail. The reserve-capacity rating is determined by the length of time, in minutes, that a fully charged battery can be discharged at 25 amperes before battery cell voltage drops below 1.75 volts per cell.

**Clasificación de capacidad en reserva** Indicación, en minutos, de cuánto tiempo un vehículo puede continuar siendo conducido, con los faros delanteros encendidos, en caso de que ocurriese una falla en el sistema de carga. La clasificación de capacidad en reserva se determina por el espacio de tiempo, en minutos, en el que una batería completamente cargada puede descargarse a 25 amperios antes de que la tensión del acumulador de la batería disminuya a un nivel inferior de 1,75 amperios por acumulador.

**Resistance** Opposition to current flow.

**Resistencia** Oposición que presenta un conductor al paso de la corriente eléctrica.

**Resistor block** Consists of two or three helically wound wire resistors wired in series.

**Bloque de resistencia** Consiste de dos o tres cables helicoidales rostáticos intercalados en serie.

**Resistive multiplex switch** Provides multiple inputs over a single circuit. Since each switch position has a different resistance value, the voltage drop is different. This means a switch can have one power supply wire and one ground wire instead of a separate wire for each switch position.

**Interruptor multiplex resistente** Provee múltiples entradas de energía sobre un circuito simple. Debido a que la posición de cada interruptor tiene un valor diferente de resistencia, el voltaje de la caída de tensión es diferente. Esto significa que un interruptor puede tener un cable de abastecimiento de energía y un cable conductor a tierra, sin que sea necesario un cable individual para cada posición del interruptor.

**Reverse-bias** A positive voltage is applied to the N-type material and negative voltage is applied to the P-type material of a semiconductor.

**Polarización inversa** Tensión positiva aplicada al material N y tensión negativa aplicada al material P de un semiconductor.

**Rheostat** A two-terminal variable resistor used to regulate the strength of an electrical current.

**Reóstato** Resistor variable de dos bornes utilizado para regular la resistencia de una corriente eléctrica.

**Right-hand rule** Identifies the direction of the lines of force of an electromagnet.

**Regla de la mano derecha** Identifica la dirección de las líneas de fuerza de un electroimán.

**ROM (read only memory)** Memory chip that stores permanent information. This information is used to instruct the computer on what to do in response to input data. The CPU reads the information contained in ROM, but it cannot write to it or change it.

**ROM (memoria de sólo lectura)** Fragmento de memoria que almacena datos en forma permanente. Dichos datos se utilizan para darle instrucciones a la computadora sobre cómo dirigir la ejecución de una operación de entrada. La UCP lee los datos que contiene la ROM, pero no puede escribir en ella o puede cambiarla.

**Rotating magnetic field** The magnetic field of the stator windings in an AC motor. The stator is stationary, but the field rotates from pole to pole.

**Campo magnético rotativo** El campo magnético de los giros de un estator en un motor de CA. El estator permanece fijo, pero el campo rota de polo en polo.

**Rotor** The component of the AC generator that is rotated by the drive belt and creates the rotating magnetic field of the AC generator.

**Rotor** Parte rotativa del generador de corriente alterna accionada por la correa de transmisión y que produce el campo magnético rotativo del generador de corriente alterna.

**Safety goggles** Eye protection device that fits against the face and forehead to seal off the eyes from outside elements.

**Gafas de seguridad** Dispositivo protector que se coloca delante de los ojos para preservarlos de elementos extraños.

**Safety stands** See Jack stands.

**Soportes de seguridad** Véase soportes de gato.

**Safing sensor** Determines if the collision is severe enough to inflate the air bag.

**Monitor de seguridad (safing sensor)** Determina si el impacto del choque es lo suficientemente grave para inflar las bolsas de aire.

**Satellite radios** Provide several commercial-free music and talk show channels using orbiting satellites to provide a digital signal.

**Radios por satélite** Proporcionan música variada sin comerciales y canales de programas de entrevistas al usar satélites en órbita que dan una señal digital.

**Saturation** 1. The point at which the magnetic strength eventually levels off, and where an additional increase of the magnetizing force current no longer increases the magnetic field strength. 2. The point where forward-bias voltage to the base leg is at a maximum. With bias voltage at the high limits, output current is also at its maximum.

**Saturación** 1. Máxima potencia posible de un campo magnético, donde un aumento adicional de la corriente de fuerza magnética no logra aumentar la potencia del campo magnético. 2. La tensión de polarización directa a la base está en su máximo. Ya que polarización directa ha alcanzado su límite máximo, la corriente de salida también alcanza éste.

**Schematic** An electrical diagram that shows how circuits are connected, but not details such as color codes.

**Esquemático** Diagrama eléctrico que muestra cómo se conectan los circuitos, pero no los detalles tales como las claves por colores.

**Schmitt trigger** An electronic circuit used to convert analog signals to digital signals or vice versa.

**Disparador de Schmitt** Un circuito electrónico que se emplea para convertir las señales análogas en señales digitales o vice versa.

**Sealed-beam headlight** A self-contained glass unit that consists of a filament, an inner reflector, and an outer glass lens.

**Faro delantero sellado** Unidad de vidrio que contiene un filamento, un reflector interior y una lente exterior de vidrio.

**Seat track position sensor (STPS)** A Hall-effect sensor that provides information to the OCM concerning the position of the seat in relation to the air bag.

**Sensor de la posición del carril de asiento (SPCA)** Sensor de efecto de Hall que proporciona información al MCS (Módulo de control de salida) que concierne a la posición del asiento en relación con la bolsa de aire.

**Secondary circuit** All the components that carry voltage to the combustion chamber.

**Circuito secundario** Todos los componentes que conducen el voltaje a la cámara de combustión.

**Secondary coil windings** One of the two coils in the ignition coil. This winding has several thousand turns and is where low voltage will be transformed to high voltage.

**Bobinas secundarias** Una o dos bobinas de tensión en la bobina de encendido. Este bobinado tiene la capacidad de millares de vueltas y de esta forma el voltaje bajo será transformado en voltaje de alta tensión.

**Secondary wiring** Conductors, such as battery cables and ignition spark plug wires, that are used to carry high voltage or high current. Secondary wires have extra thick insulation.

**Hilos secundarios** Conductores, tales como cables de batería e hilos de bujías del encendido, utilizados para transmitir tensión o corriente alta. Los hilos secundarios poseen un aislamiento sumamente grueso.

**Sector gear** The section of gear teeth on the regulator.

**Engranaje de cables** La sección de los dientes de engranaje en el regulador.

**Self-induction** The generation of an electromotive force by a changing current in the same circuit.

**Autoinducción** Este es el generamiento de la fuerza electromotriz cuando la corriente cambia en el mismo circuito.

**Semiconductor** An element that is neither a conductor nor an insulator. Semiconductors are materials that conduct electric current under certain conditions, yet will not conduct under other conditions.

**Semiconductor** Elemento que no es ni conductor ni aislante. Los semiconductores son materiales que transmiten corriente eléctrica bajo ciertas circunstancias, pero no la transmiten bajo otras.

**Sending unit** The sensor for the gauge. It is a variable resistor that changes resistance values with changing monitored conditions.

**Unidad emisora** Sensor para el calibrador. Es un resistor variable que cambia los valores de resistencia según cambian las condiciones reguladas.

**Sensing voltage** Input voltage to the AC generator.

**Detección del voltaje** Determina la tensión de entrada de energía al generador de Corriente Alterna AC.

**Sensitivity controls** A potentiometer that allows the driver to adjust the sensitivity of the automatic dimmer system to surrounding ambient light conditions.

**Controles de sensibilidad** Un potenciómetro que permite que el conductor ajusta la sensibilidad del sistema de intensidad de iluminación automático a las condiciones de luz ambientales.

**Sensor** Any device that provides an input to the computer.

**Sensor** Cualquier dispositivo que le transmite información a la computadora.

**Sentry key** Describes a sophisticated antitheft system that prevents the engine from starting unless a special key is used.

**Llave guardiante centinela** Describe un sofisticado sistema de guardia anti-robo el que evita prender el motor, a menos que se haga con una llave específicamente creada.

**Separators** Normally constructed of glass with a resin coating. These battery plates offer low resistance to electrical flow but high resistance to chemical contamination.

**Separadores** Normalmente se construyen del vidrio con una capa de resina. Estas placas de la batería ofrecen baja resistencia al flujo de la electricidad pero alta resistencia a la contaminación química.

**Sequential logic circuits** Flip-flop circuits in which the output is determined by the sequence of inputs. A given input affects the output produced by the next input.

**Circuitos de lógica secuencial** Cambia los circuitos en los cuales la salida de energía es determinada según la secuencia de las entradas de corriente. Una entrada de energía afecta la salida de corriente que va ser producida en una próxima entrada de energía.

**Sequential sampling** The process that the MUX and DEMUX operate on. This means the computer will deal with all of the sensors and actuators one at a time.

**Muestreo secuencial** La forma en que funcionan los sistemas de las abreviaturas (MUX y DEMUX). Esto significa que la computadora se encargará de que todos los monitores y actuadores funcionen uno por uno.

**Series circuit** A circuit that provides a single path for current flow from the electrical source through all the circuit's components and back to the source.

**Circuito en serie** Circuito que provee una trayectoria única para el flujo de corriente de la fuente eléctrica a través de todos los componentes del circuito, y de nuevo hacia la fuente.

**Series hybrid** Hybrid configuration where propulsion comes directly from the electric motor.

**Híbrido en serie** Configuración del híbrido en donde la propulsión llega directamente del motor eléctrico.

**Series-parallel circuit** A circuit that has some loads in series and some in parallel.

**Circuito en series paralelas** Circuito que tiene unas cargas en serie y otras en paralelo.

**Series-wound motor** A type of motor that has its field windings connected in series with the armature. This type of motor develops its maximum torque output at the time of initial start. Torque decreases as motor speed increases.

**Motor con devanados en serie** Un tipo de motor cuyos devanados inductores se conectan en serie con la armadura. Este tipo de motor desarrolla la salida máxima de par de torsión en el momento inicial de ponerse en marcha. El par de torsión disminuye al aumentar la velocidad del motor.

**Servomotor** An electrical motor that produces rotation of less than a full turn. A feedback mechanism is used to position itself to the exact degree of rotation required.

**Servomotor** Motor eléctrico que genera rotación de menos de una revolución completa. Utiliza un mecanismo de realimentación para ubicarse al grado exacto de la rotación requerida.

**Shell** The electron orbit around the nucleus of an atom.

**Corteza** Órbita de electrones alrededor del núcleo del átomo.

**Short** An unwanted electrical path; sometimes this path goes directly to ground.

**Corto** Una trayectoria eléctrica no deseable; a veces este trayectoria viaja directamente a tierra.

**Shorted circuit** A circuit that allows current to bypass part of the normal path.

**Circuito corto** Este circuito permite que la corriente pase por una parte del recorrido normal.

**Shunt** More than one path for current to flow.

**Desviación** Más de una derivación para que la corriente pueda fluir.

**Shunt circuits** The branches of the parallel circuit.

**Circuitos en derivación** Las ramas del circuito en paralelo.

**Shunt-wound motor** A type of motor whose field windings are wired in parallel to the armature. This type of motor does not decrease its torque as speed increases.

**Motor con devanados en derivación** Un tipo de motor cuyos devanados inductores se cablean paralelos a la armadura. Este tipo de motor no disminuya su par de torsión al aumentar la velocidad.

**Shutter wheel** A metal wheel consisting of a series of alternating windows and vanes. It creates a magnetic shunt that changes the strength of the magnetic field from the permanent magnet of the Hall-effect switch or magnetic pulse generator.

**Rueda obturadora** Rueda metálica compuesta de una serie de ventanas y aspas alternas. Genera una derivación magnética que cambia la potencia del campo magnético, del imán permanente del conmutador de efecto Hall o del generador de impulsos magnéticos.

**Sine wave** A waveform that shows voltage changing polarity.

**Onda senoidal** Una forma de onda que muestra un cambio de polaridad en la tensión.

**Single phase voltage** The sine wave voltage induced in one conductor of the stator during one revolution of the rotor.

**Tensión monofásica** La tensión en forma de onda senoidal inducida en un conductor del estator durante una revolución del rotor.

**Slave module** Controller on the network that must communicate through a master controller.

**Módulo esclavo** Controlador en la red que debe comunicarse por medio del control maestro.

**Slip rings** Rings that function much like the armature commutator in the starter motor; however, they are smooth.



**Anillos colectores** Estos funcionan como casi el conmutador inducido en el arranque del motor, excepto que estos anillos son lisos.

**Smart sensors** Sensors that are capable of sending digital messages on the data bus.

**Sensor inteligente** Sensores capaces de enviar mensajes digitales en el bus de datos.

**Solenoid** An electromagnetic device that uses movement of a plunger to exert a pulling or holding force.

**Solenoide** Dispositivo electromagnético que utiliza el movimiento de un pulsador para ejercer una fuerza de arrastre o de retención.

**Sound generator** See *buzzer*.

**Generador de sonido** Vea “timbre.”

**Source** The portion of a field-effect transistor that supplies the current-carrying holes or electrons.

**Fuente** Terminal de un transistor de efecto de campo que provee los agujeros o electrones portadores de corriente.

**Spark plug** Electrodes provide gaps inside each combustion chamber across which the secondary current flows to ignite the air–fuel mixture in the combustion chambers.

**Enchufe de chispa** Electrodo para proveer intervalos dentro de cada cámara de combustión a través de la corriente secundaria que fluye para encender la mezcla de aire/combustible en las cámaras de combustión.

**Specific gravity** The weight of a given volume of a liquid divided by the weight of an equal volume of water.

**Gravedad específica** El peso de un volumen dado de líquido dividido por el peso de un volumen igual de agua.

**Speedometer** An instrument panel gauge that indicates the speed of the vehicle.

**Velocímetro** Calibrador en el panel de instrumentos que marca la velocidad del vehículo.

**Squib** A pyrotechnic term used for a fire cracker that burns but does not explode. The squib starts the process of air bag deployment.

**Mecha** Un término pirotécnico usado para prender una pólvora que se quema pero no explota. La mecha inicia el proceso de la salida de la bolsa de aire.

**Start/clutch interlock switch** Used on vehicles equipped with manual transmissions.

**Interruptor de seguridad de embrague** Usado en los vehículos equipados con transmisiones manuales.

**Starter drive** The part of the starter motor that engages the armature to the engine flywheel ring gear.

**Transmisión de arranque** Parte del motor de arranque que engrana la armadura a la corona del volante de la máquina.

**Starter generator control module (SGCM)** Also called a high-voltage ECU (HV ECU). Used to control the flow of torque and electrical energy into and from the motor generator of the HEV.

**Módulo de control del generador de encendido (MCGE)** También se le llama UCE de alto voltaje (UCE AV). Se utiliza para controlar el flujo del par motor y la energía eléctrica dentro y fuera del generador del motor del VHE.

**Starting system** A combination of mechanical and electrical parts that work together to start the engine by changing the electrical energy that is being supplied by the battery into mechanical energy by use of a starter or cranking motor.

**Sistema de encendido** Combinación de partes mecánicas y eléctricas que trabajan unidas para encender el motor al cargar la energía eléctrica que proporciona la batería, en energía mecánica mediante el uso de un encendedor o motor de arranque.

**State of charge** The condition of a battery's electrolyte and plate materials at any given time.

**Estado de carga** Condición del electrolito y de los materiales de la placa de una batería en cualquier momento dado.

**Static electricity** Electricity that is not in motion.

**Electricidad estática** Electricidad que no está en movimiento.

**Static neutral point** The point at which the fields of a motor are in balance.

**Punto neutral estático** El punto en que los campos de un motor están equilibrados.

**Stator** The stationary coil of the AC generator where current is produced.

**Estátor** Bobina fija del generador de corriente alterna donde se genera corriente.

**Stator neutral junction** The common junction of Wye stator windings.

**Unión de estátor neutral** La unión común de los devanados de un estátor Y.

**Stepped resistor** A resistor that has two or more fixed resistor values.

**Resistor de secciones escalonadas** Resistor que tiene dos o más valores de resistencia fija.

**Stepper motor** An electrical motor that contains a permanent magnet armature with two or four field coils. Can be used to move the controlled device to whatever location is desired. By applying voltage pulses to selected coils of the motor, the armature will turn a specific number of degrees. When the same voltage pulses are applied to the opposite coils, the armature will rotate the same number of degrees in the opposite direction.

**Motor de pasos** Contiene una armadura magnética permanente con dos, cuatro o más bobinas del campo.

**Strain gauge** A sensor that determines the amount of applied pressure by measuring the strain a material experiences when subjected to the pressure.

**Extensómetro de resistencia eléctrica** Un sensor que determina la cantidad de presión aplicada al medir la resistencia eléctrica que experimenta un material cuando se lo somete a presión.

**Stranded wire** A conductor comprised of many small solid wires twisted together. This type conductor is used to allow the wire to flex without breaking.

**Cable trenzado** Un conductor que comprende muchos cables sólidos pequeños trenzados. Este tipo de conductor se emplea para permitir que el cable se tuerza sin quebrar.

**Sulfation** A condition in a battery that reduces its output. The sulfate in the battery that is not converted tends to harden on the plates, and permanent damage to the battery results.

**Sulfatación** Una condición en una batería que disminuya su potencia de salida. El sulfato en la batería que no se convierte suele endurecerse en las placas y resulta en daños permanentes en la batería.

**Supplemental bus networks** Bus networks that are on the vehicle in addition to the main bus network.

**Redes de bus complementarios** Redes de bus que hay en el vehículo aparte de la red del bus principal.

**Synchronous motor** Type of AC motor that operates at a constant speed regardless of load. The rotor always rotates at the speed of the rotating magnetic field.

**Motor sincrónico** Tipo de motor de CA que opera a velocidad constante sin importar la carga. El rotor siempre gira a la velocidad del campo magnético rotativo.

**Synchronous speed** The speed at which the magnetic field of the stator rotates in an AC motor.

**Velocidad sincrónica** La velocidad a la cual el campo magnético del estator gira en un motor de CA.

**Tachometer** An instrument that measures the speed of the engine in revolutions per minute (rpm).

**Tacómetro** Instrumento que mide la velocidad del motor en revoluciones por minuto (rpm).

**Terminals** Provide a means of connecting the battery plates to the vehicle's electrical system.

**Terminales** Provee los medios de conexión de las placas de batería al sistema eléctrico del vehículo.

**Termination resistors** Used to control induced voltages. Since voltage is dropped over resistors, the induced voltage is terminated.

**Resistores de terminación** Usados para controlar la conducción de los voltajes. Como el voltaje cae sobre los resistores, es así como se determina el voltaje.

**Thermistor** A solid-state variable resistor made from a semiconductor material that changes resistance in relation to temperature changes.

**Termistor** Resistor variable de estado sólido hecho de un material semiconductor que cambia su resistencia en relación con los cambios de temperatura.

**Three-coil gauge** A gauge design that uses the interaction of three electromagnets and the total field effect upon a permanent magnet to cause needle movement.

**Calibrador de tres bobinas** Calibrador diseñado para utilizar la interacción de tres electroimanes y el efecto inductor total sobre un imán permanente para producir el movimiento de la aguja.

**Throw** Term used in reference to electrical switches or relays referring to the number of output circuits from the switch.

**Posición activa** Término utilizado para conmutadores o relés eléctricos en relación con el número de circuitos de salida del conmutador.

**Thyristor** A semiconductor switching device composed of alternating N and P layers. It can also be used to rectify current from AC to DC.

**Tiristor** Dispositivo de conmutación del semiconductor compuesto de capas alternas de N y P. Puede utilizarse también para rectificar la corriente de corriente alterna a corriente continua.

**Timer circuit** Uses a bimetallic strip that opens as a result of the heat being generated by the current flow.

**Circuito Sincronizador** Consiste de una cinta bimetalica la que se abre, debido al calor generado por el flujo de corriente.

**Timer control** A potentiometer that is part of the headlight switch in some systems. It controls the amount of time the headlights stay on after the ignition switch is turned off.

**Control temporizador** Un potenciómetro que es parte del conmutador de los faros en algunos sistemas. Controla la cantidad

del tiempo que quedan prendidos los faros después de apagarse la llave del encendido.

**Timing disc** Known as an armature, reluctor, trigger wheel, pulse wheel, or timing core. It is used to conduct lines of magnetic force.

**Disco medidor de tiempo** Se conoce como una armadura de inducción, rueda disparadora, rueda de pulsación o un núcleo de tiempo. Este disco es usado para conducir líneas de fuerza magnética.

**Tire pressure monitoring systems** A safety system that notifies the driver if one or more tires are underinflated or overinflated.

**Sistema de monitoreo de la presión de las llantas** Sistema de seguridad que le hace saber al conductor si una llanta o más llantas están desinfladas o sobre infladas.

**Torque converter** A hydraulic device found on automatic transmissions. It is responsible for controlling the power flow from the engine to the transmission; works like a clutch to engage and disengage the engine's power to the drive line.

**Convertidor de par** Un dispositivo hidráulico en las transmisiones automáticas. Se encarga de controlar el flujo de la potencia del motor a la transmisión; funciona como un embrague para embragar y desembragar la potencia del motor con la flecha motriz.

**Total reflection** A phenomenon where in a light wave reflects off of the surface 100% when the light wave advances from a medium of high index of refraction to a medium of low index of refraction.

**Reflexión total** Fenómeno en el que una onda de luz se refleja 100% de una superficie cuando la onda de luz avanza de un índice medio de refracción de uno alto a uno índice medio de refracción de uno bajo.

**Tracer** A thin or dashed line of a different color than the base color of the insulation.

**Traza líneas** Una línea delgada o instrumento de color diferente al color básico de la insulación.

**Trailing edge** In a Hall-effect switch, the edges of the rotating blade that exit the switch.

**Borde de salida** Un interruptor de efecto Hall indica los bordes de la paleta giratoria que sale del interruptor.

**Transducer** A device that changes energy from one form into another.

**Transductor** Dispositivo que cambia la energía de una forma a otra.

**Transistor** A three-layer semiconductor used as a very fast switching device.

**Transistor** Semiconductor de tres capas utilizado como dispositivo de conmutación sumamente rápido.

**Trimotor** A three-armature motor.

**Trimotor** Motor de tres armaduras.

**Turn-on voltage** The voltage required to jump the PN junction and allow current to flow.

**Voltaje de conexión** El voltaje requerido para hacer funcionar el cable de empalme PN y permitir que la corriente fluya.

**TVRS** An abbreviation for television-radio-suppression cable.

**TVRS** Una abreviación del cable de supresión del televisión y radio.

**Tweeters** Smaller speakers that produce the high frequencies of treble.

**Tweeters** Pequeñas bocinas que producen altas frecuencias agudas.

**Two-coil gauge** A gauge design that uses the interaction of two electromagnets and the total field effect upon an armature to cause needle movement.

**Calibrador de dos bobinas** Calibrador diseñado para utilizar la interacción de dos electroimanes y el efecto inductor total sobre una armadura para generar el movimiento de la aguja.

**Ultra capacitor** A device that stores energy as electrostatic charge. It is the primary device in the power supply during hill climbing, acceleration, and the recovery of braking energy.

**Ultra capacitor** Dispositivo que guarda energía como carga electrostática. Es el dispositivo primario en la fuente de energía durante una subida, una aceleración y el recobro de la energía de frenado.

**Vacuum distribution valve** A valve used in vacuum-controlled concealed headlight systems. It controls the direction of vacuum to various vacuum motors or to vent.

**Válvula de distribución al vacío** Válvula utilizada en el sistema de faros delanteros ocultos controlado al vacío. Regula la dirección del vacío a varios motores al vacío o sirve para dar salida del sistema.

**Vacuum fluorescent display (VFD)** A display type that uses anode segments coated with phosphor and bombarded with tungsten electrons to cause the segments to glow.

**Visualización de fluorescencia al vacío** Tipo de visualización que utiliza segmentos ánodos cubiertos de fósforo y bombardeados de electrones de tungsteno para producir la luminiscencia de los segmentos.

**Valence ring** The outermost orbit of the atom.

**Anillo de valencia** Órbita más exterior del átomo.

**Valve body** A unit that consists of many valves and hydraulic circuits. This unit is the central control point for gear shifting in an automatic transmission.

**Cuerpo de la válvula** Una unidad que consiste de muchas válvulas y circuitos hidráulicos. Esta unidad es el punto central de mando para los cambios de velocidad en una transmisión automática.

**Valve-Regulated Lead–Acid (VRLA) battery** Another variation of the recombination battery that uses lead–acid. The oxygen produced on the positive plates is absorbed by the negative plate causing a decrease in the amount of hydrogen produced at the negative plate that is then combined with the oxygen to produce water.

**Batería de plomo-ácido de válvula regulada (VRLA, por su sigla en inglés)** Otra variante de la batería de recombinación que utiliza plomo-ácido. El oxígeno que se produce en las placas positivas es absorbido por la placa negativa, lo que causa una disminución en la cantidad de hidrógeno que se produce en la placa negativa y que luego se combina con el oxígeno para formar agua.

**Vaporized aluminum** Gives a reflecting surface that is comparable to silver.

**Aluminio vaporizado** Da a la superficie un reflejo brillante como si fuera plata.

**Variable resistor** A resistor that provides for an infinite number of resistance values within a range.

**Resistor variable** Resistor que provee un número infinito de valores de resistencia dentro de un margen.

**Vehicle instrumentation systems** A system that monitors the various vehicle operating systems and provides information to the driver of their correct operation.

**Sistemas de instrumentación del vehículo** Sistema que monitorea varios sistemas de operación del vehículo y proporciona información de su operación correcta al conductor.

**Volatile** Easily vaporizes or explodes.

**Volátil** Vaporiza o explota fácilmente.

**Volatile** RAM memory that is erased when it is disconnected from its power source. Also known as Keep Alive Memory.

**Volátil** Memoria RAM cuyos datos se perderán cuando se la desconecta de la fuente de alimentación. Conocida también como memoria de entretenimiento.

**Volt** The unit used to measure the amount of electrical force.

**Voltio** Unidad práctica de tensión para medir la cantidad de fuerza eléctrica.

**Voltage** The difference or potential that indicates an excess of electrons at the end of the circuit the farthest from the electromotive force. It is the electrical pressure that causes electrons to move through a circuit. One volt is the amount of pressure required to move one amp of current through one ohm of resistance.

**Tensión** Diferencia o potencial que indica un exceso de electrones al punto del circuito que se encuentra más alejado de la fuerza electromotriz. La presión eléctrica genera el movimiento de electrones a través de un circuito. Un voltio equivale a la cantidad de presión requerida para mover un amperio de corriente a través de un ohmio de resistencia.

**Voltage drop** A resistance in the circuit that reduces the electrical pressure available after the resistance. The resistance can be either the load component, the conductors, any connections, or unwanted resistance.

**Caída de tensión** Resistencia en el circuito que disminuye la presión eléctrica disponible después de la resistencia. La resistencia puede ser el componente de carga, los conductores, cualquier conexión o resistencia no deseada.

**Voltage limiter** Connected through the resistor network of a voltage regulator. It determines whether the field will receive high, low, or no voltage. It controls the field voltage for the required amount of charging.

**Limitador de tensión** Conectado por el red de resistores de un regulador de tensión. Determina si el campo recibirá alta, baja o ninguna tensión. Controla la tensión de campo durante el tiempo indicado de carga.

**Voltage regulator** Used to control the output voltage of the AC generator, based on charging system demands, by controlling field current.

**Regulador de tensión** Dispositivo cuya función es mantener la tensión de salida del generador de corriente alterna, de acuerdo a las variaciones en la corriente de carga, controlando la corriente inductora.

**Voltmeter** A test meter used to read the pressure behind the flow of electrons.

**Voltímetro** Instrumento de prueba utilizado para medir la presión del flujo de electrones.

**Wake-up signal** An input signal used to notify the body computer that an engine start and operation of accessories is going to be initiated soon. This signal is used to warm up the circuits that will be processing information.



**Señal despertadora** Señal de entrada para avisarle a la computadora del vehículo que el arranque del motor y el funcionamiento de los accesorios se iniciarán dentro de poco. Dicha señal se utiliza para calentar los circuitos que procesarán los datos.

**Warning lamp** A lamp that is illuminated to warn the driver of a possible problem or hazardous condition.

**Luz de aviso** Lámpara que se enciende para avisarle al conductor sobre posibles problemas o condiciones peligrosas.

**Watchdog circuit** Supplies a reset voltage to the microprocessor in the event that pulsating output voltages from the microprocessor are interrupted.

**Circuito de vigilancia** Proporciona un voltaje de reposición para el microprocesador en caso de que se interrumpan los voltajes de potencia útil de pulsaciones del microprocesador.

**Watt** The unit of measure of electrical power, which is the equivalent of horsepower. One horsepower is equal to 746 watts.

**Watio** Unidad de potencia eléctrica, equivalente a un caballo de vapor. 746 watios equivalen a un caballo de vapor (CV).

**Wattage** A measure of the total electrical work being performed per unit of time.

**Vataje** Medida del trabajo eléctrico total realizado por unidad de tiempo.

**Watt-hour rating** Equals the battery voltage times ampere-hour rating.

**Contador de voltaje-hora nominal** Su función es igualar el tiempo del voltaje de la batería con el voltaje-hora nominal.

**Weather-pack connector** A type of connector that seals the terminal's ends. This type connector is used in electronic circuits.

**Conectador impermeable** Un tipo de conector que sella las extremidades de los terminales. Este tipo de conector se emplea en los circuitos electrónicos.

**Wheatstone bridge** A series-parallel arrangement of resistors between an input terminal and ground.

**Puente de Wheatstone** Conjunto de resistores en series paralelas entre un borne de entrada y tierra.

**Window regulator** Converts the rotary motion of the motor into the vertical movement of the window.

**Regulador del vidrio parabrisas** Convierte la acción rotatoria del motor en un movimiento vertical sobre el vidrio parabrisas.

**Windshield wipers** Mechanical arms that sweep back and forth across the windshield to remove water, snow, or dirt.

**Limpiador del parabrisas** Funciona con brazos mecánicos, de un extremo al otro del vidrio, para remover agua, nieve y suciedad.

**Wiper** Moveable contact of a variable resistor.

**Limpiador** Consiste de un movimiento deslizable de resistores variables.

**Wireless networks** Connection of modules together to transmit information without the use of physical connection by wires.

**Redes inalámbricas** Conexión entre los módulos para transmitir información sin el uso de conexiones físicas por medio de alambres.

**Wiring diagram** An electrical schematic that shows a representation of actual electrical or electronic components and the wiring of the vehicle's electrical systems.

**Esquema de conexiones** Esquema en el que se muestran las conexiones internas de los componentes eléctricos o electrónicos reales y las de los sistemas eléctricos del vehículo.

**Wiring harness** A group of wires enclosed in a conduit and routed to specific areas of the vehicle.

**Cableado preformado** Conjunto de alambres envueltos en un conducto y dirigidos hacia áreas específicas del vehículo.

**Woofers** Large speakers that produce the low frequencies of midrange and bass.

**Woofers** Bocinas grandes que producen bajas frecuencias de media distancia y bajo.

**Worm gear** A type of gear whose teeth wrap around the shaft. The action of the gear is much like that of a threaded bolt or screw.

**Engranaje de tornillo sin fin** Un tipo de engranaje cuyos dientes se envuelven alrededor del vástago. El movimiento del engranaje es muy parecido a un perno enroscado o una tuerca.

**Wye wound connection** A type of stator winding in which one end of the individual windings are connected at a common point. The structure resembles the letter Y.

**Conexión Y** Un tipo de devanado estátor en el cual una extremidad de los devanados individuales se conectan en un punto común. La estructura parece la letra "Y."

**Yaw** The tendency for the vehicle to rotate around its center of gravity.

**Giro longitudinal** Tendencia de un vehículo a girar sobre su propio eje de gravedad.

**Y-type stator** A three-winding AC generator that has one end of each winding connected at the neutral junction.

**Estátor de tipo Y** Generador de corriente alterna de devanado triple; un extremo de cada devanado se conecta al empalme neutro.

**Zener diode** A diode that allows reverse current to flow above a set voltage limit.

**Diodo Zener** Diodo que permite que el flujo de corriente en dirección inversa sobrepase el límite de tensión determinado.

**Zener voltage** The voltage that is reached when a diode conducts in reverse direction.

**Tensión de Zener** Tensión alcanzada cuando un diodo conduce en una dirección inversa.

## A

- absorbed glass mat (AGM) batteries, 119
- AC (alternating current), 28, 168
- accelerometers, 276
  - G force, 276
- accumulators, 252
- AC generators, 166, 169–177
  - circuits, 179
  - components, 169–177
    - brushes, 171
    - brushless, 200
    - diode rectifier bridge, 174–177
    - generator housings, 178
    - rotors, 169–171
    - stators, 171–173
  - cooling fans, 178
  - design differences among, 193–200
    - AD200 series AC generators, 194
    - brushless AC generators, 200
    - CS series AC generator, 194
    - DaimlerChrysler generators, 196–197
    - Ford generators, 195–196
    - hybrid AC generators, 202–203
    - Mitsubishi generators, 197–200
    - 10SI series AC generator, 193–194
  - operation overview, 180–182
  - regulation of, 183–191
- A circuits, 184
- AC motors, 157–160
  - construction, 158–159
  - induction, 160–161
    - integrated starter generators, 161–162
  - synchronous, 159–160
- actuators, computer-controlled, 254–257
  - relays, 255
  - solenoids, 255–256
  - motors
    - servomotor, 256
    - stepper motor, 256–257
- AD200 series AC generators, 195
- adaptive brake lights, 322
- adaptive headlight system (AHS), 318
  - night vision, 319
- adaptive strategy capabilities, 247–248
- A/D converter, 244–245, 248, 251, 275, 283–284
- ADL. *See* automatic door locks
- AHS. *See* adaptive headlight system
- air bag control modules (ACMs). *See* occupant restraint controller (ORC)
- air bag modules, 438–440
- air bags, 438
  - air bag systems, 438–452
    - components, 438–444
      - air bag module, 438–440
      - clocksprings, 440–441
      - sensors, 442–444
      - shorting bars, 444
    - deployment of, 444
    - hybrid air bag types, 446–447
    - introduction to, 18, 438
    - multistage air bag deployment, 447–448
    - occupant classification systems and, 454–459
    - occupant restraint controller (ORC), 441
    - on/off switches, 450–452
    - passenger-side air bags, 445
    - side-impact air bags, 448–449
    - warning lamps, 445
  - air charge temperature (ACT) sensor, 248
  - air-core gauges, 339, 341
  - alarm systems. *See* antitheft systems
  - alternate propulsion systems, 12–13
  - alternating current (AC), 28, 168
  - alternative power source vehicles, 463–486
    - electric vehicles (EVs), 463–464
      - 42-volt systems, 470–476
      - fuel cells, 476–484
      - fuel types, 479–484
    - hybrid vehicles, 465–467
    - introduction to, 463
  - alternators, 166
    - See also* AC generators
  - ammeters, operation of, 191–192
  - amortisseur winding, 160
  - Ampère, André Marie, 44
  - ampere-hour rating, 126
  - amperes (A), 30, 31
  - amplification circuits, 244
  - amplified circuits, 67–68
  - AM signal, 427
  - analog instrument clusters, 334, 335, 342
  - analog signals, 244, 245
  - AND gates, 251
  - anodes, 60
  - antennas, 402–403
  - antitheft systems, 10, 404–407
    - arcing, 473
    - argon gas, 446–447
    - armatures, 134–137, 142–143
    - arming process, of antitheft systems, 405–406
    - arsenic, 60
    - asynchronous, 284
    - atomic structure, 17–18

atoms, 17–18  
    covalent bonding, 59  
    positive ions, 42  
audio entertainment systems, 422–426  
Auto-lamp/Delayed Exit, 309  
automatic door locks (ADL), 11, 398–403  
automatic headlight dimming, 313–318  
automatic on/off with time delay, 309–312  
automatic transmissions  
    electronic shift, 9  
    neutral safety switch on, 4  
automatic wiper systems, 375–376  
automotive batteries. *See* batteries  
automotive light bulbs, 209  
    *See also* lighting circuits  
automotive wiring. *See* wiring, automotive  
avalanche diodes, 63

## B

BabySmart<sup>®</sup> system, 450  
back-up lights, 229  
Baird, John Logie, 327  
balanced atoms, 20  
ballast resistors, 146  
Bardeen, John, 67  
BAS. *See* belt alternator starter  
base, 64  
batteries, 108–130  
    *See also* charging systems  
    absorbed glass mat (AGM), 119  
    conventional, 110–114  
        chemical action, 113–114  
        construction of, 111–113  
        failure of, 127–128  
    42-volt system, 120  
    functions of, 108–110  
    HEVs (hybrid electric vehicles), 121–125, 469–470  
    high-voltage, 120  
    holddowns, 128  
    hybrid, 117–118  
    introduction to, 108–11  
    lithium-ion (Li-ion), 124  
    lithium polymer (Li-Poly), 124–125  
    maintenance-free, 115–117  
    nickel-cadmium (NiCad), 122  
    nickel-metal Hydride (NiMH), 123  
    ratings, 126–128  
    recombination, 118–119  
    reserve capacity, 127  
    size selection, 127  
    terminals, 125–126  
    36-volt, 120  
    valve-regulated, 119  
battery cables, 127–128  
baud rate, 284  
B circuits, 184

BCM. *See* body control module  
Bell, Alexander Graham, 114, 327  
belt alternator starter (BAS), 162, 201, 474  
belts, drive, 167  
belt tension sensors (BTSs), 456, 457  
bimetallic strips, 73  
binary code, 241, 284  
binary numbers, 242–243  
bipolar transistors, 66, 253  
bit, 243  
blade-type fuses, 71  
blower motor circuit, 379–380  
blown fuses, 72  
Bluetooth technology, 301–302, 429  
BMW, 213, 322  
body computer. *See* body control module  
body control module (BCM), 240–258  
    *See also* data bus networks  
    analog and digital principles, 241–245  
    antitheft systems controlled by, 406  
    computer memory, 245–248  
    concealed headlight operation and, 305–307  
    control of headlight system by, 307–309  
    functions of, 240–241  
    high-side drivers, 253–254  
    illuminated entry systems and, 324  
    information processing by, 248–252  
    inputs, 260–280  
    instrument panel dimming by, 324–325  
    introduction to, 240  
    lamp outage indicators and, 327–331  
    low-side drivers, 253  
    multiplexing (MUX) systems, 286–297  
    outputs, 254–257  
    Twilight Sentinel System and, 311  
bonding straps. *See* ground straps  
boron, 60  
brake lights, 222–224, 226  
    neon, 227, 231  
Brattain, Walter Houser, 67  
brushes  
    AC generator, 171  
    armature, 135–136  
brushless AC generators, 200  
brushless motors, 141–142  
BTSs. *See* belt tension sensors  
bucking coil, 336  
buffer circuits, 339  
Bulb Test, 353  
bulkhead connectors, 89  
bullet fuses, 71  
bus (+) circuit, 287–289  
bus (–) circuit, 287, 289–290  
bus data links, 9, 283  
bus networks. *See* data bus networks  
buzzers, 56–57

## C

- cabin compartment node (CCN), 316
- cable reel assembly. *See* clocksprings
- cables
  - battery, 127–128
  - fiber-optic, 298, 300, 301
- California Air Resource Board (CARB), 463
- CAN. *See* controller area network
- capacitance, 41–43
- capacitors, 41–43
- carriers, 435
- cartridge fuses, 71
- cathodes, 60
- cell elements, 111–112
- cellular telephones, 423, 429–430
- CEMF. *See* counter electromotive force
- center high mounted stop lamp (CHMSL), 223
- central gateway (CGW) module, 296–297
- central processing units (CPUs), 245
  - input signals processed by, 260–280
- ceramic fuses, 71
- Chappe, Claude, 327
- charging systems, 166–206
  - AC generatorsw, 180–182
    - circuits, 179
    - components, 169–177
    - design differences in, 193–200
    - operation overview, 180–182
  - charging indicators, 191–193
  - components, 5, 167
  - DC/DC converters, 204
  - HEVs (hybrid electric vehicles), 201–202
  - introduction to, 5, 166–167
  - principles of operation, 167–169
  - regenerative braking, 202–204
  - regulation of, 183–191
  - schematic of, 180
- child-safety latches, 394
- Chrysler Collision Detection (CCD) system, 287–290
- circuit breakers, 73–74
- circuit defects, 75–78
  - high resistance, 77–78
  - opens, 75
  - shorts, 75–77
- circuit diagrams. *See* wiring diagrams
- circuit numbering, on wiring diagrams, 95–102
- circuit protection devices, 70–75
  - circuit breakers, 73–74
  - fuses, 70–72
  - fusible links, 72
  - maxi-fuses, 73
  - PTCs, 74–75
- circuits, 28–39
  - AC generator, 179
  - amplified, 67–68
  - application of Ohm's law, 35–38
  - buffer, 339
  - closed, 28
  - components of. *See* electrical components
  - cranking motor circuits, 144
  - decoder, 251
  - defined, 20–21
  - defogger, 382–383
  - driver, 254
  - field, 184–185
  - ground side of, 28
  - headlight, 216–217
  - horn, 359
  - insulated side of, 28
  - integrated circuits (ICs), 69, 251
  - lighting, 208–237
  - open, 28
  - parallel, 31–33
  - parts of, 28
  - power door lock, 394–397
  - power seat, 389–391
  - printed, 90–91
  - prove-out, 353
  - resistance in, 23
  - RS flip-flop, 252
  - series, 29–31
  - series-parallel, 33–35
  - starter control, 144–152
  - watchdog, 348
  - wiper, 364–376
- clamping diodes, 63–64
- Class B data bus networks, 290–291
- clock circuits, 243
- clocked RS flip-flop circuits, 251
- clocksprings, 360–361, 362
- closed circuits, 28
- clutch, overrunning clutch, 143–145
- coil assembly. *See* clocksprings
- coil spring unit. *See* clocksprings
- cold cranking amps (CCA), 126
- cold cranking rating, 126
- collectors, 64
- color codes, on wiring diagrams, 95–102
- common connections (splices), 89, 90
- communication networks, 283–303
  - communication protocols, 284–286
  - data bus networks, 286–302
  - introduction to, 9, 283–284
- communication protocols
  - ISO 14230-4, 285
  - ISO 9141-2, 285
  - J1850, 285–286
  - J2284/ISO 15765-4, 286
  - OBD II, 284
- commutator, 135
- component locators, 102–104

- composite headlights, 212
- compound motors, 139
- computer-controlled concealed headlights, 305–306
- computer-controlled headlight systems, 306–308
- computer-controlled voltage regulation, 189–191
- computer memory, 245–247
- computer networks, 2
  - See also* communication networks
- computer nodes, 283
- computers
  - See also* body control module (BCM)
  - functions of, 9
  - introduction to, 9
- concealed headlights, 217–220
  - computer-controlled, 305–306
- conduction, 66
- conductors, 3, 19–20, 23, 59
- conduits, 92
- connectors, 87–89
- contact reel. *See* clocksprings
- continuity, 28
- controller area network (CAN), 292–297
- control module
  - See also* body control module (BCM)
  - for cruise control systems, 409–410
- control panel assembly, 325
- conventional batteries, 110–114
- conventional theory, 22
- cooling fans, 178
- copper, 19
- cornering lights, 227–228
- corrugated loom, 92
- counter electromotive force (CEMF), 47, 139
- courtesy lights, 234
- covalent bonding, 59–60
- CPUs. *See* central processing units
- cranking amps (CA), 126
- cranking motor circuits, 144–147
- cranking motor designs, 152–156
- crash sensors, 442
- cruise control systems, 10, 409–417
  - components, 410–411
  - introduction to, 409–410
  - principles of operation, 412
  - safety modes, 411
- crystals, 60
- CS series AC generator, 193–200
- current flow
  - in capacitors, 42–43
  - electromagnetism and, 44–46
  - excess, 71
  - field current, 167, 180

- through AC generator, 180–183
- through charging system, 167
- through power door lock circuit, 395
- through power window circuits, 388–389
- through transistors, 65
- in wipers, 364–273
- current (I)
  - AC, 28
  - DC, 28
  - defined, 21–22
  - types of, 27
- current limiters, 183
- cutoff, 66

## D

- DaimlerChrysler
  - AC generators, 196–197
  - wiring codes of, 102
- Darlington pair, 67–68
- d'Arsonval gauge, 336
- data bus networks, 297–302
  - Class A, 287–290
  - Class B, 290–291
  - controller area networks, 292–297
  - local interconnect network, 297
  - Media Oriented System Transport (MOST), 298–302
  - PCI, 290–293
  - supplemental, 297–302
  - wireless networks, 300–302
- data encryption, 301
- daytime running lamps (DRL), 320–322
- DC/DC converters, 473
- DC generators, 166, 169
- DC motors, winding designs
  - compound motors, 139
  - permanent magnet motors, 140–141
  - series-wound motors, 138–139
  - shunt-wound motors, 139
- DC voltage, 27
- decoder circuits, 251
- deep cycling, 116
- defoggers, 7, 382–383
- Delphi bladder system, 455–457
- delta wound stator, 173, 177–178
- demultiplexer (DEMUX), 251
- depressed-park wiper systems, 372–374
- diaphragm, 359
- dielectric, 41–43
- digital displays. *See* digital gauges
- digital gauges, 348–349
- digital instrumentation clusters, 342–348
  - electronic fuel gauges, 348
  - odometers, 345–347
  - speedometers, 343–345
  - tachometers, 347–348
- digital signals, 241–244

- dimmer switches, 216–220
- DIN, 105
- diode rectifier bridge, 174–175, 181
- diodes, 60–64
  - avalanche, 63
  - clamping, 63–64
  - identification, 61–62
  - light-emitting, 63
  - photo, 63
  - ratings, 61–62
  - zener, 62–63, 186
- diode trio, 179
- direct current (DC), 27
- direct drive starters, 153
- display panels. *See* digital gauges
- door locks, power, 8, 56, 255, 395–397
- double-filament lamps, 209
- double start override, 148
- drive belts, 167, 169
- drive coils, 153–154
- driver circuits, 252
- drivers
  - high side, 253–254, 308
  - low side, 253–254
- dual-generator systems, 472
- dual-stator, dual-voltage systems, 472
- dual-voltage systems, 471–473
- duty cycle, 254
- DVD systems, 428–429

## E

- easy exit feature, 10
- ECM. *See* engine control module
- eddy currents, 136
- EEPROM (electrically erasable PROM), 247
- electrical circuits. *See* circuits
- electrical components, 51–78
  - buzzers, 56–57
  - circuit protection devices, 70–78
  - introduction to, 51
  - relays, 54–55
  - resistors, 57–59
  - solenoids, 55–56
  - switches, 52–54
- electrical laws, 24–34
  - Kirchhoff's law, 39–41
  - Ohm's law, 24–26, 35–38
  - Watt's law, 26–27
- electrical pressure, 20
- electrical symbols, 94–95
- electrical systems
  - alternate propulsion systems, 12–13
  - charging system, 4–5
  - computers, 8
  - electronic accessories. *See* electronic accessory systems

- ignition system, 5–6
- introduction to, 2–14
- lighting system, 5–6
- networks of, 2
- passive restraint systems, 12
- starting system, 2–4
- in today's vehicles, 17
- vehicle communication networks, 9
- vehicle instrumentation systems, 6
- electrical system technician, reasons to become a, 1–2
- electric backlight (EBL), 383
- electric defoggers, 7, 382–383
- electricity
  - capacitance, 41–43
  - conductors of, 19–20
  - defined, 19–23
  - laws of, 24–27
  - magnetism and, 43–46
  - role of, in automobiles, 2
  - static, 42
  - theory of induction and, 46–47
- electric motors, 139–142, 467
- electric vehicles (EVs), 12, 463–464
- electrochemical, 108
- electrochromic mirrors, 385
- electrolysis, 115, 481
- electrolyte solution, 111–112
- electromagnetic field wiper circuits, 366–374
- electromagnetic gauges, 335
- electromagnetic induction, 5, 167–168
- electromagnetic interference (EMI)
  - defined, 47
  - suppression of, 48
- electromagnetic motors, 134–136
- electromagnetic switches. *See* relays
- electromagnetism, 44–46
- electromagnets, 43
- electromechanical gauges, 335–338
- electromotive force (EMF), 20, 21
- electron flow, 21
  - basics of, 17–19
- electronic, integrated circuits (ICs), 69
- electronic accessory systems, 9–14, 358–431
  - ABS systems, 466–469
  - antitheft systems, 404–407
  - audio entertainment systems, 422–428
  - automatic door locks (ADL), 398–399
  - blower motors, 379–381
  - climate-controlled seats, 433–434
  - cruise control systems, 409–412
  - defoggers, 382–383
  - DVD systems, 428–429
  - electronic sunroofs, 12, 412–417
  - hands-free cellular telephones, 429–430



- heated windshield systems, 417–422
- horns, 359–363
- immobilizer systems, 407–408
- introduction to, 8–10, 246, 408–409
- keyless entry systems, 12–13, 399–401
- keyless start systems, 401–403
- memory seats, 392–394
- navigation systems, 430
- power door locks, 10, 394–397
- power mirrors, 7–8, 383–386
- power seats, 389–391
- power windows, 8, 386–389
- shift transmissions, 9, 240
- tire pressure monitoring systems, 464
- washer pumps, 376–379
- windshield wipers, 363–376, 417–422
- electronic components, 59–69
  - diodes, 60–64
  - phototransistors, 68–69
  - thyristors, 69
  - transistor amplifiers, 75–76
  - transistors, 64–68
- electronic cruise control systems. *See* cruise control systems
- electronic fuel gauges, 348
- electronic heated windshield, 417–422
- electronic instrument panels. *See* digital instrumentation clusters
- electronic regulators, 185–191
- electronic shift transmissions, 9, 240
- electronic sunroofs, 10, 412–417
- electronic suspension systems, 2, 9, 240
- electronic throttle control (ETC) systems, 412
- electrons, 17–18, 19, 41–42
- electron theory, 22
- electrostatic field, 42
- EMI. *See* electromagnetic interference
- emitters, 64
- emission standards, 463–464
- energy density, 122
- engine control module (ECM), 419
- enhancement-type FETs, 67
- entertainment systems
  - audio, 422–428
  - DVD systems, 428–429
- EPROM (erasable PROM), 247
- equivalent series loads, 33
- ethanol, 480
- EVR (external voltage regulator) charging system, 196
- exclusive-OR (XOR) gates, 250
- exterior lights, 220–233
  - back-up lights, 229
  - cornering lights, 227–28
  - fog lights, 229
  - LED, 227
  - neon third brake lights, 227
  - parking lights, 221

- side marker lights, 229–233
- taillight assemblies, 221–224
- turn signal lights, 224–227

## F

- fade-to-off feature, 323
- farads, 43
- Federal Motor Vehicle Safety Standard, 454
- feedback signals, 279
- fiber optics, 326–327
- field circuits, 184–185
- field coils, 137–138
- field current, 170, 180
  - regulation of, 183–191
- field-effect transistors (FETs), 66
- fifth percentile female weight classification, 454, 456–457, 458
- filaments, 209, 210, 211
- fixed resistors, 57
- flash-to-pass option, 221, 313
- flooded batteries, 112
- FM signal, 427
- fog lights, 229
- Ford
  - AC generators, 195–196
  - color codes used by, 101
  - heated windshield system, 417
- forward-biased diodes, 61
- 42-volt systems, 120–121, 471–476
  - dual, 471
  - single, 471
- front parking lights, 220
- “F”-type fuses, 73
- fuel cell-powered vehicles, 13, 476
- fuel cells, 13, 476–477
- fuel data centers, 350
- fuel pump inertia switch, 437
- full parallel hybrid configuration, 467–468
- full-wave rectification, 176
- fuse block, 71
- fuses, 70–72
- fusible links, 72

## G

- ganged switches, 52–53
- gasoline, 480
- gassing, 115
- gauge numbers, 84
- gauges
  - air-core, 338
  - d’Arsonval, 335–336
  - digital, 342–349
  - electromagnetic, 378
  - electromechanical, 335–338
  - electronic fuel gauges, 348
  - instrument, 334
  - magnetic bobbin, 336

- quartz analog, 338–341
- sending units, 341–342
- strain, 265
- stress, 265
- temperature, 348–349
- three-coil, 336
- two-coil, 336–337
- gear reduction starters, 153
- gear sets, planetary, 202
- gel-cell batteries, 118
- General Motors (GM)
  - AD200 series AC generators, 195
  - CS series AC generator, 194
  - electric cars of, 464
  - electronic sunroofs, 417
  - heated windshield system, 418–419
  - lamp indicator module, 330
  - 10SI series AC generator, 193
  - wiring codes of, 102
- generator housings, 178
- generators, 28
  - AC, 166, 169–178
  - DC, 166, 169
  - integrated starter generators (ISGs), 474–476
  - liquid-cool, 178–179
  - magnetic induction and, 46
  - magnetic pulse, 269–271
- germanium, 59
- G force, 276
- glass fuses, 71
- grid growth, 116
- grids, 110
- grids, defogger, 382
- ground, 22
- grounded circuits, 77
- ground straps, 85–86

**H**

- half-wave rectification, 175
- Hall, Edwin Herbert, 276
- Hall-effect switch, 273–275
  - Schmitt trigger, 274
  - shutter wheel, 273–274
- halogen headlights, 211
- hands-free cellular telephones, 429–430
- hands-free module (HFM), 429
- Hansell, Clarence W., 327
- hazard warning system, 226–227
- headlight circuits, 216–217
- headlight leveling system (HLS), 318–319
  - adaptive headlights, 318–319
- headlights, 209–214
  - automatic dimming, 313–318
  - automatic on/off with time delay, 309–313
  - composite, 212
  - computer-controlled, 307–309

- concealed, 217–220
  - computer-controlled, 305–307
- daytime running lamps, 320–322
- “flash to pass” feature, 220
- halogen, 211
- headlight leveling system (HLS), 318
- HID, 8, 212–214
  - sealed-beam, 210–211
  - wrap-around, 230
- headlight switches, 214–216
- headlight wipers, 363
- head-up display (HUD), 349–350
- heated gas inflator (HGI), 447
- heated windshield system, 14, 417–422
- heat shrink covered butt connectors, 89
- heat sinks, 178, 196
- HEV batteries, 121–125
  - lithium-ion (Li-ion), 124
  - lithium-polymer (Li-Poly), 124–125
  - nickel-cadmium (NiCad), 122
  - nickel-metal hydride (NiMH), 123–124
- HEV charging system, 201–202
  - DC/DC converter, 204
  - regenerative braking, 202–203
- H-gate, 345–346
- high beams, automatic dimming of, 313–318
- high-intensity discharge (HID) headlights, 6, 212–213
- high-note horns, 359
- high-reading coil, 336–337
- high-resistance problems, 77–78
- high side drivers (HSD), 253, 308
- high-voltage batteries, 120
- high-voltage ECU (HV ECU), 476
- holddowns, 128
- hold-in winding, 145–146
- hole, 60
- hole-flow theory, 22
- Honda Civic Hybrid, 470
- Honda Insight, 470
- horn circuits, 361–362
- horns, 7, 359–362
- horn switches, 359–360
- horsepower, 26
- hybrid AC generators, 202
- hybrid air bag types, 446–447
- hybrid batteries, 117–118
- hybrid electric vehicles (HEVs), 13, 465–470
  - components, 466–467
  - examples of, 469–470
  - introduction to, 465–466
  - propulsion of, 467–469
- hydrogen, 476–477
- Hydrogen on Demand catalyst, 482
- hydrometers, 116

## I

- IC chips, 241, 346–347
- igniters, 439–440
- ignition coil, 46
- ignition switch, 3, 148–149, 150
- ignition system
  - components, 5
  - introduction to, 4–5
- illuminated entry systems, 305, 323–324
- illumination lights, 236
- immobilizer systems, 407
- incandescence, 209
- indicator lights, 191, 236, 334
  - fiber-optic, 326–327
- induction, theory of, 46–48
- inductive reactance, 183
- inertia lock retractors, 435
- inflatable knee blockers (IKBs), 454
- information processing, 248–252
- inputs, computer, 260–280
  - accelerometers, 276
  - feedback signals, 314
  - introduction to, 260–261
  - sensors, 260–275
  - switch, 277–279
  - thermistors, 261–263
- installation diagrams, 102
- instrumentation systems, 6, 334–355
  - computer-driven, 334
  - digital, 342–349
    - odometers, 345–346
    - speedometers, 343–345
    - tachometers, 347–348
  - electromechanical gauges, 335–338
  - electronic fuel gauges, 348
  - gauge sending units, 341–342
  - head-up display (HUD), 349–350
  - introduction to, 8, 334
  - lamp outage indicators, 327–330
  - quartz analog instrumentation, 339–341
  - travel information systems, 350–351
  - warning lamps, 353–355
- instrument cluster gauges, 339–341
- instrument cluster lights, 214
- instrument panel dimming, 324–325
- insulators, 19–20, 59
- integrated circuits (ICs), 69, 241
- integrated motor assist (IMA) system, 470
- integrated power module (IPM), 308
- integrated starter generators (ISGs), 474–476
- Intel, 297
- intelligent windshield wiper systems, 375–376
- interfaces, computer, 244
- interior lights, 233–235
  - courtesy lights, 234
  - instrument cluster lights, 236

- reading and map lights, 235
- intermittent wipers, 369–372
- International Standards Organization (ISO), 55, 285, 343
- intrusion monitors, 407
- invalid keys, 408
- ions, 20
- ISO 14230-4 protocol, 285
- ISO 9141-2 protocol, 285
- ISO-K data bus, 285, 286
- isolated field circuit, 184–185
- ISO relays, 55, 56

## J

- J1850 protocol, 285–286
- J2284/ISO 15765-4 protocol, 286

## K

- keep alive memory (KAM), 247
- Kettering, Charles F., 134
- keyless entry systems, 11, 399–403
- Keyless Go system, 401
- keyless start systems, 401–403
- K-line, 285
- Kirchhoff's law, 39–41
  - current, 39–40
  - voltage, 40–41

## L

- laminated construction, 136
- Lamm, Heinrich, 327
- lamp outage indicators, 327–331
- lamp outage module, 327–339
- lamps, 209
- lead acid batteries, 112, 114
- lead calcium batteries, 115–117
- lead peroxide, 110, 113–114
- lean burn technology, 470
- LED exterior lighting, 227
- light bulbs, 209
- light-emitting diodes (LEDs), 63, 323
- lighting circuits, 208–237
  - advanced, 305–374
  - complexity of, 208
  - concealed headlights, 217–220
    - computer-controlled, 305–306
  - exterior lights, 220–233
  - fiber optics, 326–327
  - “flash to pass” feature, 220
  - headlights, 210–214
    - automatic dimming, 312–318
    - automatic on/off with time delay, 309–312
    - computer-controlled, 307–308
    - daytime running lamps, 320–322
    - headlight leveling system, 318–319
  - headlight switches, 214–216
  - illuminated entry systems, 323–324

- instrument panel dimming, 324–325
- interior lights, 233–236
- introduction to, 5–6, 208, 305
- lamp outage indicators, 327–331
- lamps, 209–214
- liquid-fueled air bag modules, 447
- L-line, 285
- load device, 57
- local interconnect network (LIN) bus system, 297
- logic gates, 249–252
- low-note horns, 359
- low-reading coil, 336–337
- low-side drivers, 253, 374
- LUX, 317

## M

- magnetically coupled linear sensors, 272–273
  - comb, 272
  - resistor card, 272
- magnetic bobbin gauge, 336–337
- magnetic fields, 43, 44, 45, 166–167, 270
  - motors and, 133–138
- magnetic flux density, 43, 45
- magnetic induction, 46–47
- magnetic pulse generators, 269–271
  - pickup coil, 269
  - timing disc, 269
- magnetic sensors, 47
- magnetic switches, 4, 144–147
  - remote, 150–151
  - starter-mounted solenoids, 144–147
- magnetism, principles of, 43–46
- magnetoresistive effect, 271
- magnetoresistive sensor, 271–272
- magnets, 43
- maintenance-free batteries, 115–116
- manual transmissions, start/clutch interlock
  - switch on, 4
- map lights, 235
- master module, 285, 297–299
- material expanders, 110
- maxi-fuses, 73
- mechanical instrument cluster (MIC), 340
- Media Oriented System Transport (MOST)
  - data bus, 298–299
- memory, computer, 245–248
- memory effect, 122
- memory seats, 10, 392–394
- mercury switches, 53–54
- methanol, 480
- metri-pack connectors, 89
- microfarads, 43
- microprocessors, 245
- mild parallel hybrid configuration, 467–468
- mirrors, power, 7–8, 383–384
- Mitsubishi, AC generators, 197–200
- Model T Ford, 214
- molded connectors, 87

- motor circuits, cranking, 144
- motor feed circuit, 144
- motors
  - See also* AC motors
  - armature, 136–137
  - blower, 379–381
  - brushless, 141–142
  - compound, 139
  - electric, 464, 467
  - electromagnetic field, 366–373
  - field coils, 137
  - permanent magnet, 140–141
  - principles of, 133–140
  - series-wound motors, 138–139
  - servomotors, 256, 409–410
  - shunt-wound, 139
  - stepper, 256, 345–346
  - trimotors, 389–390
  - wiper, 364–365, 368–378
- moveable-pole shoe starters, 153–154
- multiple-wire, hard-shell connectors, 88, 89
- multiplexers (MUX), 251, 428
- multiplexing, 9
- multiplexing (MUX) systems, 286–297
  - advantages of, 283–284
  - Class A data bus network, 287–290
  - Class B data bus networks, 290–291
  - communication protocols, 284–286
  - controller area networks, 292–297
- multistage air bags, 447–448
- mutual induction, 46

## N

- NAND gates, 250
- navigation systems, 430
- negative logic, 414
- negative temperature coefficient (NTC)
  - thermistors, 262
- neon third brake lights, 227, 231
- networks, 2
  - See also* communication networks
- neutral safety switch, 4
- nodes, 283
- nonmultiplexed systems, 284
- NOR gates, 250
- normally closed (NC) switch, 52
- normally open (NO) switch, 52
- NOT gates, 252
- NPN transistors, 64–66
- N-type materials, 60–61, 64, 66
- nucleus, 24–25
- NVRAM (nonvolatile RAM), 247

## O

- OBD II communication protocols, 284, 285
- occupant classification systems, 454–512
  - Delphi bladder system, 454–457
  - TRW strain gauge system, 457–459

- occupant restraint controller (ORC), 441
- odometers, 345–346
- ohms, 23
- Ohm's law, 24–26, 30, 35–38
- open circuits, 28, 75
- OR gates, 249–250
- oscillator, 348
- outputs, computer, 254–257
  - driver, 254
  - signal, 254
- overcharging, batteries, 115, 116, 119
- overload, 71
- overrunning clutch, 143–145

## P

- panel lights, 236
- parallel branches, 31
- parallel circuits, 33–35
- parallel hybrid configuration, 467–468
- park contacts, 364
- parking lights, 221, 231–232
- passenger-side air bags, 445
- passive restraint systems, 434–5
  - air bag systems, 438–553
  - inflatable knee blockers, 454
  - introduction to, 12, 434
  - occupant classification systems, 454–459
  - seat belt pretensioners, 453
  - seat belt systems, 435–437
- passive seat belt systems, 435–437
- PCM. *See* powertrain control module
- permanent magnet gear reduction (PMGR), 154–156
- permanent magnet motors, 140–141
- permanent magnet (PM) generator, 339, 343–344
- permanent magnets, 43
- permanent magnet starters, 154–156
- permanent magnet wiper circuits, 364–365
- permeability, 45
- personal identification number (PIN), 302
- photocells, 309–313, 315
- photo diodes, 63, 298–299
- phototransistors, 68–69
- pickup coil, 269–270
- picofarads, 43
- piconets, 302
- piezoelectric devices, 266–267
- piezoresistive devices, 265
- pinion factor, 340–341
- pinion gear, 142–144
- planetary gear sets, 155–156, 470
- polarity, 43
- pole, 52
- pole shoes, 134, 136
- polymers, 74
- polymethyl methacrylate (PMMA), 299

- positive-engagement starters, 153–154
- positive ions, 42
- positive plate, 41–42
- positive temperature coefficient (PTC) resistors, 74
- positive temperature coefficient (PTC) thermistors, 262
- potentiometers, 58, 261, 268–269
- power distribution boxes, 71
- power door locks, 8, 394–396
- power mirrors, 7–8, 383–385
  - automatic rear view mirrors, 384
  - electrochromic mirrors, 385
- power (P), 26–27
- power seats, 389–391
  - memory seats, 392–394
- powertrain control module (PCM), 145, 147
  - regulator function of, 189–191
- power windows, 8, 386–388
- pretensioners, 453
- primary wiring, 82
- printed circuit boards, 90–91
- prisms, 210
- Prius, 469–470
- Programmable Communication Interface (PCI) bus system, 286, 290–291
- programs, computer, 245
- PROM (programmable read only memory), 245, 246, 247
- propulsion, 467–469
- protection devices, 70, 74–75, 92–93
- protocols, communication, 284–286
- proton exchange membrane (PEM), 476–478
- protons, 17–19, 20
- prove-out circuits, 353–354
- P-type materials, 60–61, 64
- pull-in winding, 145–146
- pulse-width modulation (PWM), 142, 161, 204, 213, 324, 473
- pyrotechnology, 439

## Q

- quartz analog instrumentation, 339–341

## R

- radial pattern, 117
- radio choke, 425
- radios, 422–428
- radio transmission, 301
- RAM (random access memory), 245, 247
- ratings, battery, 126–128
- ratio, 143
- reading lights, 235, 323
- rear-terminal AC generators, 195–196
- rear view mirrors, 315–316
- recombination batteries, 118–119
- rectification, 174–176, 197, 202
- rectifier bridge (stack), 169, 174–175, 181

- reformers, 480–481
- regenerative braking, 121, 202–203, 464, 467
- registers, 252
- regulators
  - electronic, 185–187
  - voltage, 183, 184–186
- relay-controlled wiper systems, 368–369
- relays, 54–55
  - exterior light, 220–221
  - function of, 255
  - horns and, 359
  - ISO, 55
  - solenoid, 55–56
  - starter, 144–145, 147–148
  - wipers and, 368–369
- relay switches, 3
- reluctance, 46
- remote keyless entry, 401
- remote solenoids, 147
- reserve capacity, 110, 117
- reserve-capacity rating, 127
- resistance
  - calculating, 25
  - defined, 23
  - high-resistance problems, 77–78
  - in parallel circuit, 31–33
  - in series circuit, 29–31
  - in series-parallel circuit, 33–35
  - termination, 287–290
  - wire, 85
- resistance wire, 209
- resistive multiplex switch, 278
- resistor block, 379–381
- resistors, 57–58
  - fixed, 57
  - potentiometer, 58
  - stepped, 58
  - termination, 287
  - variable, 58
- reverse-biased diodes, 65
- rheostats, 58
- right-hand rule, 44–45
- ring gear, 142–143
- ROM (read only memory), 245, 246–247
- rotating magnetic field, 158
- rotors, 169–171
- RS flip-flop circuits, 252

## S

- SAE (Society of Automotive Engineers), 126
- Safeguard Sentinel, 309
- safety switch, starter, 149–151
- safing sensors, 439, 442
- Sargrove, J. A., 91
- satellite radio, 427–428
- saturation, 46, 66

- schematics. *See* wiring diagrams
- Schmitt trigger, 274
- sealed-beam headlights, 210–211
- seat belt pretensioners, 453
- seat belt systems, 435–437
- seat belt tension sensors, 457
- seats
  - memory, 392–394
  - power, 389–391
- seat track position sensor (STPS), 458–459
- secondary wiring, 82
- sector gear, 387
- self-induction, 47
- self-tests, by digital gauges, 349
- semiconductors, 20, 59–62
  - diodes, 60–61
  - phototransistors, 68–69
  - thyristors, 68
  - transistor amplifiers, 67–68
  - transistors, 64–67
- sending unit-controlled lamps, 353–354
- sensing voltage, 183
- sensitivity controls, 313
- sensors, 307–313
  - air bag, 442–444
  - belt tension, 457
  - capacitance discharge, 268
  - Hall-effect switch, 273–275
  - magnetic, 47
  - magnetic pulse generators, 269–271
  - magnetically coupled linear sensors, 272–273
  - magnetoresistive sensor, 271–272
  - motion detection, 268
  - oxygen, 261
  - piezoelectric devices, 266–267
  - piezoresistive devices, 265, 341
  - position detection, 268
  - potentiometers, 264–265
  - pressure, 263
  - seat track position, 459
  - smart, 297
  - speed, 268, 269, 271, 340–341, 343–346
  - thermistors, 261–263
  - tire pressure, 300, 464
  - Wheatstone bridges, 265–267
- sentry key, 148
- sequential sampling, 251
- series circuits, 29–31
- series hybrid vehicles, 469
- series-parallel circuits, 33–35
- series-wound motors, 138–139
- servomotors, 256, 410
- servos, 409–411, 412
- shell, atom, 18
- shift transmissions, electronic, 9, 240
- Shockley, William Bradford, 67



shorted circuits, 75–76  
 shorting bars, 444  
 short to ground, 75–77  
 shunt circuits, 31  
 shunt-wound motors, 139  
 shutter wheel, 273–274  
 side-impact air bags, 448–449  
 side marker lights, 229–233  
 side-terminal AC generators, 195–196  
 signal conditioning/conversion, 244  
 silicon, 59  
 silicon-controlled rectifier (SCR), 59, 69  
 sine waves, 173, 176  
 single-filament bulbs, 209  
 single-phase voltage, 158, 159  
 slave modules, 285, 297  
 slip rings, 170, 171  
 SmartBeam system, 315–318  
     *See also* automatic headlight dimming  
 smart sensors, 297  
 Society of Automotive Engineers (SAE), 126  
 sodium borohydride, 481–483  
 solenoid relay, 147  
 solenoids, 55–56  
     computer control of, 255  
     remote, 147  
     starter-mounted, 147–148  
 solenoid switches, 3  
 solid-fuel hybrid air bags, 446  
 solid oxide fuel cells, 481  
 solid-state devices, 59  
 sound generators, 56–57  
 sound systems, 422–425  
 spark plug wires, 82  
 Spaulding touring car, 235  
 speakers, 425–426  
 specific gravity, 113  
 speedometers, 339–341, 343–345, 350  
 speed-sensitive wipers, 376  
 speed sensors, 268–269, 271, 341–343  
 splices, 90, 102  
 squib, 439–440  
 squirrel-cage, 160  
 stacked-type rectifiers, 196  
 Standard Corporate Protocol (SCP), 285  
 start/clutch interlock switch, 4, 150  
 starter control circuit, 144–152  
     components, 144–150  
         ignition switch, 148–149, 1  
         magnetic switches, 144–147  
         starter relay controls, 147–148  
         starting safety switch, 149–152  
     PCM, 147–148, 150  
 starter drives, 142–144  
 starter generator control module (SGCM), 475, 476  
 starter motors, 3, 134–142  
     designs, 152–156  
     direct drive, 153  
     gear reduction, 153  
     permanent magnet, 154–156  
     positive-engagement, 153–154  
 starter relay, 147–151  
 starting safety switch, 149–151  
 starting systems, 133–162  
     components of, 2–3, 132  
     cranking motor circuits, 143  
     cranking motor designs, 152–156  
     introduction to, 2–4, 133  
     motor principles, 133–142  
     starter control circuit, 144–152  
     starter drives, 142–143  
 static electricity, 42  
 static neutral point, 135  
 stator neutral junction, 173  
 stators, 171–182, 183, 186–188, 191  
 stepped resistors, 58  
 stepper motor, 256, 45–346  
 stereos, 422–428  
 strain gauge, 265  
 stranded wire, 83–84  
 stress gauge, 265  
 sunroofs, electronic, 10, 411–422  
 supplemental bus networks, 297–302  
 supplemental inflatable restraint. *See* air bag systems  
 supplemental restraint systems (SRSs). *See* air bag systems  
 switches, 52–54  
     dimmer, 216, 220  
     front wiper, 278  
     fuel pump inertia switch, 437  
     ganged, 52  
     Hall-effect, 273–275  
     headlight, 214–216  
     horn, 359–360  
     ignition, 3, 148–149  
     input devices, computers, 277–279  
     magnetic, 3, 144–147  
     mercury, 53–54  
     neutral safety, 4  
     normally closed (NC), 52  
     normally open (NO), 54  
     resistive multiplex, 307  
     single-pole, double-throw (SPDT), 52  
     single-pole, single-throw (SPST), 52  
     start/clutch interlock, 4, 150  
     starting safety, 149–151  
 synchronous speed, 159

## T

tachometers, 347–348  
 taillight assemblies, 221–224  
 TCM. *See* transmission control module

Teetor, Ralph R., 409  
temperature, charge rate and, 184  
temperature gauge, 283, 338, 341, 343  
terminals, 87–90  
    battery, 125–126  
termination resistance, 294–297  
termination resistors, 287–288  
10SI series AC generator, 193–194  
thermionic valves, 62  
thermistors, 261–262, 341  
36-volt batteries, 120  
three-coil gauges, 336–337  
three-phase rectification, 176  
three-phase voltage, 174, 180  
three-speed wiper motors, 367–368  
throw, 52  
thyristors, 69  
timer controls, 309–311  
timing disc, 269–270  
tire pressure monitoring systems, 265–266  
total reflection, 299  
Toyota Crown Sedan (2002), 120  
Toyota electronic sunroofs, 412–416  
Toyota Prius, 469–470  
tracer, 101, 102  
transducers, 264  
transistor amplifiers, 67–68  
transistors  
    bipolar, 66  
    field-effect transistors (FETs), 249  
    operating conditions, 66–67  
    phototransistors, 68–69  
transmission control module (TCM), 248  
transmissions, electronic shift, 9, 240  
travel information systems, 350–352  
trimotors, 389–390  
trip odometer readings, 346  
TRW strain gauge system, 457–459  
tungsten, 211  
turn signal lights, 222–223, 224–227, 232  
12 volt/14 volt system, 120  
Twilight Sentinel System, 309  
    *See also* automatic on/off with time delay  
two-coil gauge, 337–338  
two-speed wiper motors, 368–369

## U

ultra capacitors, 125

## V

vacuum fluorescent displays, 349  
vacuum tube devices, 62  
valence ring, 18–20  
valve-regulated batteries, 119  
valve-regulated lead acid (VRLA) batteries, 119  
vaporized aluminum, 210

variable pulse-width modulation (VPWM), 290  
variable pulse width (VPW) data bus, 286  
variable resistors, 58  
vehicle communication networks. *See* communication networks  
vehicle speed sensors (VSS), 343–345, 412  
vibration, battery failure and, 128  
voice recognition technology, 429–430  
voltage  
    defined, 20–21  
    regulation of, 183–191  
    sensing, 183  
    single-phase, 158, 159  
    three-phase, 174, 180  
    zener, 62  
voltage drop  
    calculating, 26  
    defined, 23  
voltage regulators, 5, 183–191  
voltage sense circuits, computer switches  
    diagnostic resistor, 278  
    floating, 277  
    front wiper, 278  
    pull-down circuit, 277–278  
    pull-down resistor, 277  
    pull-up circuit, 277–278  
    pull-up resistor, 277  
voltage signals, analog and digital, 241–243  
voltmeters, 341  
    measuring voltage drop with, 26  
    operation of, 192–193  
volt (V), 20

## W

“wake-up” signals, 323  
warning lamps, 236, 353–355  
    air bag, 445  
    charging system, 191  
    computer-driven, 355  
    introduction to, 334  
    sending unit-controlled, 353–354  
washer pumps, 376–377  
watchdog circuits, 348  
watts, 26–27  
Watt’s law, 26–27  
wave-wound armature, 137  
weather-pack connectors, 89  
Wheatstone bridges, 265–266  
wheel speed sensors, 341  
windings, 169–173  
window regulators, 387  
windows, power, 8, 386–388  
windshields, heated, 14, 417–422

- windshield washers, 376–378
- windshield wipers, 9, 363–379
  - circuits, 264–271
  - depressed-park wiper systems, 372–374
  - headlight, 363
  - intelligent, 14, 375–376
  - intermittent, 369–372
  - motors, 364
  - relay-controlled, two-speed, 366–367
  - schematic of, 365
- wipers, 52–53
- wireless bus networks, 300–301
- wire loom, 92
- wire resistance, 85
- wire sizes, 83–85
- wiring, automotive, 82–92
  - connectors, 87–90, 88–90
  - ground straps, 85–86
  - primary wiring, 82
  - printed circuit boards, 90–91
  - resistance wire, 82–83

- secondary wiring, 82
- spark plug wires, 82
- stranded wire, 83
- terminals, 87–90
- wire sizes, 83–85
- wiring harnesses, 91–92
- wiring diagrams, 93–103
  - circuit numbering on, 95–102
  - color codes on, 95–102
  - component locators, 102–103
  - electrical symbols on, 94–95
  - identification numbers, 102
  - installation diagrams, 102
- wiring harnesses, 91–92
- wiring protection devices, 92
- wye wound connection, 173, 176, 177

## **Z**

- zener diodes, 62–63, 186
- zener voltage, 62–63
- zero speed sensors. *See* magnetoresistive sensor

*TODAY'S TECHNICIAN™*

# AUTOMOTIVE ELECTRICITY & ELECTRONICS

5TH EDITION

SHOP MANUAL



We Support  
ASE Program Certification  
Through



**BARRY HOLLEMBEAK**

***TODAY'S TECHNICIAN***™

**SHOP MANUAL** FOR  
**AUTOMOTIVE ELECTRICITY  
AND ELECTRONICS**

**FIFTH EDITION**

**BARRY HOLLEMBEAK**



---

Australia • Canada • Mexico • Singapore • Spain • United Kingdom • United States

**Today's Technician™: Automotive Electricity and Electronics, 5th Edition**  
**Barry Hollembeak**

Vice President, Career and Professional  
Editorial: Dave Garza

Director of Learning Solutions: Sandy Clark

Executive Editor: David Boelio

Managing Editor: Larry Main

Senior Product Manager: Matthew Thouin

Editorial Assistant: Jillian Borden

Vice President, Career and Professional  
Marketing: Jennifer McAvey

Marketing Director: Deborah S. Yarnell

Marketing Manager: Katie Hall

Associate Marketing Manager: Mark Pierro

Production Director: Wendy Troeger

Production Manager: Mark Bernard

Content Project Manager: Cheri Plasse

Art Director: Benj Gleeksman

© 2011 Delmar, Cengage Learning

ALL RIGHTS RESERVED. No part of this work covered by the copyright herein may be reproduced, transmitted, stored, or used in any form or by any means graphic, electronic, or mechanical, including but not limited to photocopying, recording, scanning, digitizing, taping, Web distribution, information networks, or information storage and retrieval systems, except as permitted under Section 107 or 108 of the 1976 United States Copyright Act, without the prior written permission of the publisher.

For product information and technology assistance, contact us at  
**Professional Group Cengage Learning Customer & Sales Support, 1-800-354-9706**

For permission to use material from this text or product,  
submit all requests online at **[cengage.com/permissions](http://cengage.com/permissions)**.

Further permissions questions can be e-mailed to  
**[permissionrequest@cengage.com](mailto:permissionrequest@cengage.com)**.

Library of Congress Control Number: 2010923010

ISBN-13: 978-1-4354-7009-5

ISBN-10: 1-4354-7009-5

**Delmar**

5 Maxwell Drive

Clifton Park, NY 12065-2919

USA

Cengage Learning is a leading provider of customized learning solutions with office locations around the globe, including Singapore, the United Kingdom, Australia, Mexico, Brazil and Japan. Locate your local office at:

**[international.cengage.com/region](http://international.cengage.com/region)**

Cengage Learning products are represented in Canada by Nelson Education, Ltd.

For your lifelong learning solutions, visit **[delmar.cengage.com](http://delmar.cengage.com)**

Visit our corporate website at **[cengage.com](http://cengage.com)**.

**Notice to the Reader**

Publisher does not warrant or guarantee any of the products described herein or perform any independent analysis in connection with any of the product information contained herein. Publisher does not assume, and expressly disclaims, any obligation to obtain and include information other than that provided to it by the manufacturer. The reader is expressly warned to consider and adopt all safety precautions that might be indicated by the activities described herein and to avoid all potential hazards. By following the instructions contained herein, the reader willingly assumes all risks in connection with such instructions. The publisher makes no representations or warranties of any kind, including but not limited to, the warranties of fitness for particular purpose or merchantability, nor are any such representations implied with respect to the material set forth herein, and the publisher takes no responsibility with respect to such material. The publisher shall not be liable for any special, consequential, or exemplary damages resulting, in whole or part, from the readers' use of, or reliance upon, this material.



# CONTENTS

---

<b>Photo Sequence Contents</b> .....	<b>vi</b>
<b>Job Sheets Contents</b> .....	<b>vii</b>
<b>Preface</b> .....	<b>ix</b>
<b>CHAPTER 1 Safety</b> .....	<b>1</b>
Introduction 1 • Personal Safety 2 • Tool and Equipment Safety 7 • Lifting the Vehicle 8 • Running the Vehicle While in the Shop 13 • Fire Hazards and Prevention 14 • Hazardous Materials 19 • Electrical System Safety 23 • General Hybrid Electric Vehicle Safety 27 • High-Voltage Service Plug 30 • Summary 32 • Terms to Know 32 • ASE-Style Review Questions 33	
<b>CHAPTER 2 Special Tools and Procedures</b> .....	<b>41</b>
Introduction 41 • Basic Electrical Troubleshooting 42 • Test Equipment 43 • Multimeters 45 • Lab Scopes and Oscilloscopes 56 • Scan Tools 62 • Static Strap 65 • Memory Keepers 66 • Service Information 66 • Working as an Electrical Systems Technician 69 • Summary 74 • Terms to Know 75 • ASE-Style Review Questions 76 • ASE Challenge Questions 77	
<b>CHAPTER 3 Basic Electrical Troubleshooting and Service</b> .....	<b>95</b>
Introduction 95 • Testing for Circuit Defects 96 • Testing Circuit Protection Devices 104 • Testing and Replacing Electrical Components 108 • Testing Diodes 113 • Testing Transistors 115 • Digital Storage Oscilloscope (DSO) 116 • Case Study 122 • Terms to Know 122 • ASE-Style Review Questions 122 • ASE Challenge Questions 124	
<b>CHAPTER 4 Wiring Repair and Reading Circuit Diagrams</b> .....	<b>139</b>
Introduction 139 • Wire Repair 140 • Replacing Fusible Links 148 • Repairing Connector Terminals 149 • Ground Straps 154 • Reading Wiring Diagrams 154 • Case Study 159 • Terms to Know 159 • ASE-Style Review Questions 159 • ASE Challenge Questions 160	
<b>CHAPTER 5 Battery Diagnosis and Service</b> .....	<b>185</b>
Introduction 185 • General Precautions 186 • Battery Inspection 187 • Charging the Battery 189 • Maintaining Memory Functions 191 • Battery Test Series 191 • Battery Drain Test 200 • Battery Removal and Cleaning 202 • Jumping the Battery 206 • HV Battery Service 207 • Recycling Batteries 213 • Case Study 214 • Terms to Know 214 • ASE-Style Review Questions 214 • ASE Challenge Questions 216	
<b>CHAPTER 6 Starting System Diagnosis and Service</b> .....	<b>229</b>
Introduction 229 • Starting System Service Cautions 230 • Starting System Troubleshooting 230 • Testing the Starting System 235 • Starter Motor Removal 245 • Starter Motor Disassembly 247 • Starter Motor Component Tests 249 • Starter Reassembly 254 • Case Study 256 • Terms to Know 256 • ASE-Style Review Questions 257 • ASE Challenge Questions 258	
<b>CHAPTER 7 Charging System Testing and Service</b> .....	<b>267</b>
Introduction 267 • Charging System Service Cautions 269 • AC Generator Noises 269 • Charging System Troubleshooting 270 • Voltage Output Testing 270 • Voltage Drop Testing 272 • Field Current Draw Test 274 • Current Output Testing 275 • Full Field Test 275 • Regulator Test 282 • Diode/Stator Test 282 • Diode Pattern Testing 283 • Charging System Requirement Test 285 • AC Generator	

# CONTENTS

---

Removal and Replacement 286 • AC Generator Disassembly 291 • AC Generator Component Testing 294 • AC Generator Reassembly 297 • HEV Inverter/Converter 298 • Case Study 299 • Terms to Know 299 • ASE-Style Review Questions 299 • ASE Challenge Questions 300

## **CHAPTER 8 Lighting Circuits Repair and Diagnosis . . . . .311**

Introduction 311 • Headlights 312 • Concealed Headlights 322 • Headlight Switch Testing and Replacement 323 • Dimmer Switch Testing and Replacement 326 • Taillight Assemblies 329 • Interior Lights 335 • Lighting System Complexity 338 • Case Study 342 • Terms to Know 342 • ASE-Style Review Questions 342 • ASE Challenge Questions 343

## **CHAPTER 9 Body Computer System Diagnosis . . . . .355**

Introduction 355 • Electronic Service Precautions 357 • Diagnosis of Computer Voltage Supply and Ground Circuits 358 • Diagnostic Trouble Codes 364 • Visual Inspection 365 • Entering Diagnostics 365 • Testing Actuators 368 • Flashing the BCM 373 • Case Study 374 • Terms to Know 374 • ASE-Style Review Questions 375 • ASE Challenge Questions 376

## **CHAPTER 10 Sensor Diagnostic Routines . . . . .391**

Introduction 391 • Intermittent Faults 392 • Diagnosing Temperature Sensors and Their Circuits 394 • Diagnosing Pressure Sensors 397 • Diagnosing Position and Motion Detection Sensors 407 • Terms To Know 417 • Case Study 418 • ASE-Style Review Questions 418 • ASE Challenge Questions 420

## **CHAPTER 11 Vehicle Multiplexing Diagnostics . . . . . 447**

Introduction • 447 • Communication Fault Codes 447 • ISO 9141-2 Bus System Diagnostics 448 • ISO-K Bus System Diagnostics 450 • Class A Bus System Diagnostics 452 • J1850 Bus System Diagnostics 454 • Controller Area Network Bus Diagnostics 457 • Local Interconnect Network Bus Diagnostics 460 • Enhanced Scan Tool Diagnostics 462 • Case Study 463 • Terms to Know 463 • ASE-Style Review Questions 464 • ASE Challenge Questions 465

## **CHAPTER 12 Advanced Lighting Systems Diagnosis and Service . . . . . 487**

Introduction 487 • Computer-Controlled Concealed Headlight Diagnosis 487 • Testing Computer-Controlled Headlight Systems 489 • Automatic Headlight System Diagnosis 492 • Headlight Leveling Systems 503 • Illuminated Entry System Diagnosis 507 • Fiber Optics Diagnosis 511 • Case Study 511 • Terms to Know 511 • ASE-Style Review Questions 511 • ASE Challenge Questions 513

## **CHAPTER 13 Instrumentation and Warning Lamp System Diagnosis and Repair . . . . . 527**

Introduction 527 • Instrument Panel and Printed Circuit Removal 528 • BCM Diagnostics 529 • Self-Diagnostics 529 • Speedometer Diagnosis and Repair 534 • Tachometer 539 • Conventional Instrument Cluster Gauge Diagnosis 539 • Electronic Gauge Diagnosis 543 • Gauge Sending Units 544 • Warning Lamps 544 • Trip Computers 547 • Case Study 548 • Terms to Know 548 • ASE-Style Review Questions 548 • ASE Challenge Questions 549

# CONTENTS

---

<b>CHAPTER 14</b>	<b><i>Electrical Accessories Diagnosis and Repair</i></b>	<b>561</b>
Introduction 561 • Horn Diagnosis 562 • Wiper System Service 566 • Diagnosing Computer-Controlled Wiper Systems 574 • Automatic Wiper System Diagnosis 577 • Windshield Washer System Service 579 • Blower Motor Service 581 • Electric Defogger Diagnosis and Service 584 • Power Window Diagnosis 587 • Power Seat Diagnosis 589 • Memory Seat Diagnosis 589 • Power Door Lock Diagnosis 591 • Automatic Door Lock System Troubleshooting 591 • Remote Keyless Entry Diagnosis 593 • Antitheft System Troubleshooting 594 • Immobilizer System Service 596 • Diagnosis and Service of Electronic Cruise Control Systems 599 • Electronic Sunroof Diagnosis 611 • Electronically Heated Windshield Service 612 • Audio and Video Entertainment 615 • Case Study 617 • Case Study 618 • Terms to Know 618 • ASE-Style Review Questions 618 • ASE Challenge Questions 619		
<b>CHAPTER 15</b>	<b><i>Servicing Passive Restraint Systems</i></b>	<b>643</b>
Introduction 643 • Automatic Seat Belt Service 643 • Air Bag Safety and Service Warnings 644 • Diagnostic System Check 645 • Retrieving Fault Codes 645 • Air Bag System Testing 648 • Inspection After an Accident 651 • Cleanup Procedure After Deployment 651 • Component Replacement 651 • Occupant Classification System Service 655 • Case Study 658 • Terms to Know 658 • ASE-Style Review Questions 659 • ASE Challenge Questions 660		
<b>CHAPTER 16</b>	<b><i>Hybrid and High-Voltage System Service</i></b>	<b>673</b>
Introduction 673 • Safety Precautions 673 • High-Voltage Service Plug 675 • Self-Diagnosis Capabilities 676 • High-Voltage Battery Service 677 • Inverter/Converter Assembly 680 • System Main Relay 682 • Terms to Know 682 • Case Study 683 • ASE-Style Review Questions 683 • ASE Challenge Questions 684		
<b>Appendix A</b>	<b><i>ASE Practice Examination</i></b>	<b>689</b>
<b>Appendix B</b>	<b><i>Metric Conversions</i></b>	<b>696</b>
<b>Appendix C</b>	<b><i>Electrical and Electronic Special Tool Suppliers</i></b>	<b>697</b>
<b>Appendix D</b>	<b><i>J1930 Terminology List</i></b>	<b>698</b>
<b>Glossary</b>		<b>705</b>
<b>Index</b>		<b>723</b>

## PHOTO SEQUENCES

---

1. Using a Dry Chemical Fire Extinguisher . . . . .	18
2. HEV High-Voltage Isolation . . . . .	29
3. Performing a Voltage Drop Test . . . . .	49
4. Voltage Drop Test to Locate High Circuit Resistance. . . . .	102
5. Identifying Bipolar Transistors . . . . .	117
6. Soldering Copper Wire. . . . .	143
7. Splicing Shielded Wires . . . . .	147
8. Performing a Battery Capacity Test. . . . .	198
9. Removing and Clearing the Battery . . . . .	204
10. Typical Procedure for Delco Remy Starter Disassembly. . . . .	248
11. Typical Procedure for Disassembly of Gear reduction Starter . . . . .	250
12. Performing the Current Output Test . . . . .	276
13. Typical Procedure for Inspecting and Replacing a Serpentine Belt . . . . .	290
14. Typical Procedure for IAR Generator Disassembly. . . . .	292
15. Replacing a Sealed-Beam Headlight. . . . .	313
16. Removal and Testing of the Multifunction Switch. . . . .	327
17. Typical Procedure for Scan Tester Diagnosis . . . . .	367
18. Flashing a BCM . . . . .	373
19. Typical Procedure for Testing Frequency-Generating Sensors . . . . .	404
20. Advanced Scan Tool Functions. . . . .	462
21. Typical Procedure for Replacing a Photocell Assembly . . . . .	494
22. Automatic High-Beam Camera Calibration . . . . .	500
23. Bench Testing the Fuel Level Sender Unit. . . . .	545
24. Wiper Motor Removal . . . . .	573
25. Inspection of Rain Sensor Module . . . . .	580
26. Typical Procedure for Grid Wire Repair . . . . .	586
27. Typical Procedure for Testing the Antitheft Relay. . . . .	597
28. Typical Procedure for Replacing the Cruise Control Servo Assembly. . . . .	610
29. Typical Procedure for Removing the Air Bag Module . . . . .	653
30. Occupant Classification Validation. . . . .	657

## JOB SHEETS

---

1. Shop Safety Survey . . . . .	35
2. Fire Hazard Inspection. . . . .	37
3. Hybrid Safety . . . . .	39
4. Using ohm's Law to Calculate Electrical Properties . . . . .	79
5. Meter Symbol Interpretation . . . . .	85
6. Using a Test Light . . . . .	87
7. Use of a Voltmeter . . . . .	89
8. Use of an Ohmmeter . . . . .	91
9. Testing for an Open Circuit . . . . .	125
10. Testing for a Short to Ground. . . . .	127
11. Testing Circuit Protection Devices. . . . .	129
12. Testing Switches. . . . .	131
13. Testing a Diode. . . . .	133
14. Using a DSO on Sensors and Switches . . . . .	135
15. Part Identification on a Wiring Diagram . . . . .	171
16. Using a Component Locator . . . . .	173
17. Using a Wiring Diagram. . . . .	175
18. Soldering Copper Wires . . . . .	183
19. Inspecting and Cleaning a Battery . . . . .	217
20. Removing, Cleaning, and Installing a Battery. . . . .	219
21. Testing the Battery's Capacity . . . . .	221
22. Using a Battery Conductance Tester . . . . .	223
23. HV Battery Service and Diagnosis . . . . .	225
24. Current Draw Test . . . . .	261
25. Testing the Starting System Circuit . . . . .	263
26. Inspecting Drive Belts. . . . .	303
27. Testing Charging System Output . . . . .	305
28. Testing the Charging System Circuit . . . . .	307
29. Diagnosing Lighting Systems. . . . .	345
30. Checking a Headlight Switch. . . . .	347
31. Headlight Aiming. . . . .	349
32. Testing Computer Power and Ground Circuits . . . . .	379
33. Using a Scan Tool. . . . .	383

34. Flashing a BCM . . . . .	387
35. Testing an Engine Coolant Temperature Sensor . . . . .	421
36. Testing PTCs Used for Circuit Protection. . . . .	425
37. Pressure Switch Analysis . . . . .	427
38. Testing the Potentiometer . . . . .	429
39. DMM Testing of the Magnetic Induction Sensor . . . . .	431
40. Lab Scope Testing a Magnetic Induction Sensor . . . . .	433
41. Building Magneto-resistive Sensor Tester. . . . .	435
42. Active Speed Sensor Circuit Diagnosis . . . . .	437
43. Testing the Hall-Effect Sensors . . . . .	439
44. ISO 9141-2 Bus System Diagnosis . . . . .	467
45. ISO-K Bus System Diagnosis . . . . .	471
46. J1850 Bus System Diagnosis. . . . .	473
47. CAN Bus System Diagnosis . . . . .	479
48. LIN Bus System Diagnosis . . . . .	483
49. Testing an Automatic Headlight System . . . . .	515
50. Testing the BCM-Controlled Headlight System. . . . .	517
51. Diagnosing Automatic High-Beam Systems. . . . .	521
52. Checking a Fuel Gauge . . . . .	551
53. Testing an Oil Pressure Warning Light Circuit . . . . .	553
54. Testing the Electronic Instrument Cluster . . . . .	555
55. Diagnosing a Windshield Wiper Circuit . . . . .	621
56. Testing the Windshield Washer Circuit. . . . .	623
57. Testing a Rear Window Defogger . . . . .	625
58. Testing the Electronic Cruise Control System . . . . .	627
59. Testing the Antitheft System Operation . . . . .	629
60. Programming an Immobilizer Key . . . . .	631
61. Working Safely Around Air Bags . . . . .	661
62. Diagnosing “Driver Squib Circuit Open” Fault. . . . .	663
63. Clockspring Replacement and Centering . . . . .	667
64. Occupant Classification System Validation Procedure . . . . .	669
65. Hybrid Safety . . . . .	685
66. Hybrid System DTCs. . . . .	687



## PREFACE

---

Thanks to the support the *Today's Technician*<sup>TM</sup> series has received from those who teach automotive technology, Delmar Cengage Learning, the leader in automotive related textbooks, is able to live up to its promise to provide new editions of the series every few years. We have listened and responded to our critics and our fans and present this new updated and revised fifth edition. By revising this series on a regular basis, we can respond to changes in the industry, changes in technology, changes in the certification process, and to the ever-changing needs of those who teach automotive technology.

We also listened to instructors when they said something was missing or incomplete in the last edition. We responded to those and the results are included in this fifth edition.

The *Today's Technician*<sup>TM</sup> series, by Delmar Cengage, features textbooks that cover all mechanical and electrical systems of automobiles and light trucks. Principally the individual titles correspond to the certification areas for 2009 areas of ASE (National Institute for Automotive Service Excellence) certification.

Additional titles include remedial skills and theories common to all of the certification areas and advanced or specific subject areas that reflect the latest technological trends.

This new edition, like the last, was designed to give students a chance to develop the same skills and gain the same knowledge that today's successful technician has. This edition also reflects the changes in the guidelines established by the National Automotive Technicians Education Foundation (NATEF) in 2008.

The purpose of NATEF is to evaluate technician training programs against standards developed by the automotive industry and recommend qualifying programs for certification (accreditation) by ASE. Programs can earn ASE certification upon the recommendation of NATEF. NATEF's national standards reflect the skills that students must master. ASE certification through NATEF evaluation ensures that certified training programs meet or exceed industry-recognized, uniform standards of excellence.

The technician of today and for the future must know the underlying theory of all automotive systems and be able to service and maintain those systems. Dividing the material into two volumes, a Classroom Manual and a Shop Manual, provides the reader with the information needed to begin a successful career as an automotive technician without interrupting the learning process by mixing cognitive and performance learning objectives into one volume.

The design of Delmar's *Today's Technician*<sup>TM</sup> series was based on features that are known to promote improved student learning. The design was further enhanced by a careful study of survey results, in which the respondents were asked to value particular features. Some of these features can be found in other textbooks, while others are unique to this series.

Each Classroom Manual contains the principles of operation for each system and subsystem. The Classroom Manual also contains discussions on design variations of key components used by the different vehicle manufacturers. It also looks into emerging technologies that will be standard or optional features in the near future. This volume is organized to build upon basic facts and theories. The primary objective of this volume is to allow the reader to gain an understanding of how each system and subsystem operates. This understanding is necessary to diagnose the complex automobiles of today and tomorrow. Although the basics contained in the Classroom Manual provide the knowledge needed for diagnostics, diagnostic procedures appear only in the Shop Manual. An understanding of the underlying theories is also a requirement for competence in the skill areas covered in the Shop Manual.

A coil ring–bound Shop Manual covers the “how-to’s.” This volume includes step-by-step instructions for diagnostic and repair procedures. Photo Sequences are used to illustrate some of the common service procedures. Other common procedures are listed and are accompanied with fine line drawings and photos that allow the reader to visualize and conceptualize the finest details of the procedure. This volume also contains the reasons for performing the procedures, as well as when that particular service is appropriate.

The two volumes are designed to be used together and are arranged in corresponding chapters. Not only are the chapters in the volumes linked together, the contents of the chapters are also linked. This linking of content is evidenced by marginal callouts that refer the reader to the chapter and page that the same topic is addressed in the other volume. This feature is valuable to instructors. Without this feature, users of other two-volume textbooks must search the index or table of contents to locate supporting information in the other volume. This is not only cumbersome, but also creates additional work for an instructor when planning the presentation of material and when making reading assignments. It is also valuable to the students, with the page references they also know exactly where to look for supportive information.

Both volumes contain clear and thoughtfully selected illustrations. Many of which are original drawings or photos specially prepared for inclusion in this series. This means that the art is a vital part of each textbook and not merely inserted to increase the numbers of illustrations.

The page layout, used in the series, is designed to include information that would otherwise break up the flow of information presented to the reader. The main body of the text includes all of the “need-to-know” information and illustrations. In the wide side margins of each page are many of the special features of the series. Items that are truly “nice-to-know” information such as simple examples of concepts just introduced in the text, explanations or definitions of terms that are not defined in the text, examples of common trade jargon used to describe a part or operation, and exceptions to the norm are explained in the text. This type of information is placed in the margin, out of the normal flow of information. Many textbooks attempt to include this type of information and insert it in the main body of text; this tends to interrupt the thought process and cannot be pedagogically justified. By placing this information off to the side of the main text, the reader can select when to refer to it.

### **HIGHLIGHTS OF THIS EDITION—CLASSROOM MANUAL**

Upon opening the covers of the 5th Edition of *Today’s Technician Automotive Electricity and Electronics*, you will immediately notice the use of colored photos and illustrations that greatly enhance the visual quality of the text and the learning experience of the student. The text layout has also been improved for easier reader comprehension.

Not only does the textbook have a fresh look, the text of the 5th Edition was updated throughout to include the latest developments. Although chapter 16 covers details associated with alternate powered vehicles, all pertinent information about hybrid vehicles is included in the main text that concerns relative topics. For example, the discussion of batteries in Chapter 5 includes coverage of HEV batteries and ultra-capacitors. Chapter 6 now includes AC motor principles and the operation of the integrated starter/generator. Chapter 7 includes the HEV charging system including regenerative braking and the DC/DC converter.

The flow of basic electrical to more complex electronic systems has been maintained. Rearrangement of chapters has been utilized to enhance this flow and reduce redundancy.

Chapter 1 introduces the student to the automotive electrical and electronic systems with a general overview. This chapter emphasizes the interconnectivity of systems in today's vehicles, and describes the purpose and location of the subsystems, as well as the major components of the system and subsystems. The goal of this chapter is to establish a basic understanding for students to base their learning on. All systems and subsystems that are discussed in detail later in the text are introduced and their primary purpose described. The second chapter covers the underlying basic theories of electricity and now includes discussion of Kirchoff's laws. This is valuable to the student and the instructor because it covers the theories that other textbooks assume the reader knows. All related basic electrical theories are covered in this chapter.

Chapter 3 applies those theories to the operation of electrical and electronic components, and Chapter 4 covers wiring and the proper use of wiring diagrams. Emphasis is on using the diagrams to determine how the system works and how to use the diagram to isolate the problem.

The chapters that follow cover the major components of automotive electrical and electronic systems, such as batteries, starting systems and motor designs, charging systems, and basic lighting systems. This is followed by chapters that detail the functions of the body computer, input components, and vehicle communication networks. From here the student is guided into specific systems that utilize computer functions.

Current electrical and electronic systems are used as examples throughout the text. Most of these systems are discussed in detail. This includes computer-controlled interior and exterior lighting, night vision, adaptive lights, instrumentation, and electrical/electronic accessories. Coverage includes intelligent wiper, immobilizer, and adaptive cruise control systems to name a few. Chapter 15 details the passive restraint systems currently used.

Jack Erjavec

### **HIGHLIGHTS OF THIS EDITION—SHOP MANUAL**

Like the Classroom Manual, the Shop Manual has a new layout with color photographs and illustrations. The Shop Manual was updated to match current trends. Service information related to the new topics covered in the Classroom Manual is included in this manual. In addition, several new photo sequences were added. The purpose of these detailed photos is to show students what to expect when they perform the same procedure. They also help familiarize students with a system or type of equipment they may not be able to encounter at their school. Although the main purpose of the textbook is not to prepare someone to successfully pass an ASE exam, all the information required to do so is included in the textbook.

To stress the importance of safe work habits, Chapter 1 is dedicated to safety, and has been updated to include general HEV safety. As with the Classroom Manual, HEV system diagnosis is included within the main text. This provides the student with knowledge of safe system diagnosing procedures so they know what to expect as they further their training in this area. Included in this chapter are common shop hazards, safe shop practices, safety equipment, and the legislation concerning and the safe handling of hazardous materials and wastes.

Chapter 2 covers special tools and procedures. This chapter now includes the use of isolation meters and expanded coverage of scan tools. In addition, a section on what it entails to be an electrical systems technician has been added. This section covers relationships, completing the

## PREFACE

---

work order and ASE certification. Another section was added to emphasize the importance of proper diagnostic procedures.

Chapter 3 leads the student through basic troubleshooting and service. This includes the use of various test equipment to locate circuit defects and how to test electrical and electronic components. Chapter 4 provides experience with wiring repairs along with extended coverage and exercises on using the wiring diagrams.

The remainder of the chapters has been thoroughly updated. Redundancy between the Classroom Manual and the Shop Manual has been reduced; the only time theory is discussed again is if it is necessary to explain the diagnostic results or as an explanation of the symptom. The Shop Manual is cross-referenced to the Classroom Manual by the use of marginal notes. This provides the benefit to the student of being able to quickly reference the theory of the component or system that they are now working with.

Currently accepted service procedures are used as examples throughout the text. These procedures also served as the basis for new job sheets that are included in the Shop Manual chapters.

Features of the Classroom Manual include the following:

## COGNITIVE OBJECTIVES

These objectives define the contents of the chapter and define what the student should have learned upon completion of the chapter.

*Each topic is divided into small units to promote easier understanding and learning.*

Chapter 12

## ADVANCED LIGHTING CIRCUITS

UPON COMPLETION AND REVIEW OF THIS CHAPTER, YOU SHOULD BE ABLE TO UNDERSTAND AND DESCRIBE:

- The operation of common computer-controlled concealed headlight systems.
- The function of the computer-controlled headlight system.
- The function of automatic headlight on/off and time delay features.
- The operation of most common types of automatic headlight dimming systems.
- The operation of the SmartBeam headlight system as an example of today's sophisticated headlight systems.
- The function of automatic headlight leveling systems.
- The operation of adaptive headlight systems.
- The purpose and function of daytime running lamps.
- The operation of adaptive brake light systems.
- The operation of common illuminated entry systems.
- The operation of common instrument panel dimming systems.
- The use and function of fiber optics.
- The purpose and operation of lamp outage indicators.

**INTRODUCTION**

With the addition of solid-state circuitry in the automobile, manufacturers have been able to incorporate several different lighting circuits or modify the existing ones. Some of the refinements that were made to the lighting system include automatic headlight washers, automatic headlight dimming, automatic on/off with timed delay headlights, and illuminated entry systems. Some of these systems use sophisticated body computer-controlled circuitry and fiber optics.

Some manufacturers have included such basic circuits as turn signals into their body computer to provide for pulse width dimming in place of a flasher unit. The body computer can also be used to control instrument panel lighting based on inputs, including if the side marker lights are on or off. By using the body computer to control many of the lighting circuits, the amount of wiring has been reduced. In addition, the use of computer control has provided a means of self-diagnosis in some applications.

**COMPUTER-CONTROLLED CONCEALED HEADLIGHTS**

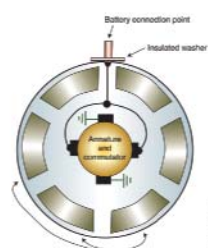
The body control module (BCM) has been utilized by some manufacturers to operate the concealed headlight system. The BCM will receive inputs from the headlight and flash-to-pass switches (Figure 12-1). When the headlight switch is turned on, the BCM receives a signal that the headlights are being activated. To open the headlight doors, the BCM energizes the open door relay. The contacts of the open relay are closed and battery voltage is applied to the door motor. In this example, battery voltage to operate the door motor is supplied from

Shop Manual  
Chapter 12,  
page 487

308

## CROSS-REFERENCES TO THE SHOP MANUAL

Reference to the appropriate page in the Shop Manual is given whenever necessary. Although the chapters of the two manuals are synchronized, material covered in other chapters of the Shop Manual may be fundamental to the topic discussed in the Classroom Manual.



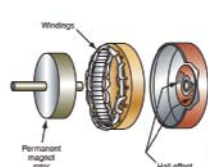
Permanent magnets

**FIGURE 6-19** A permanent magnet motor has only an armature coil, as the field is created by strong permanent magnets.

**Brushless Motors**

The brushless motor uses a permanent magnet rotor and electromagnet field windings (Figure 6-20). Since the motor design is brushless, the potential for arcing is decreased and longer service life is expected. In addition, arcing can cause electromagnetic interference (EMI) that can adversely affect electronic systems. High output brushless DC motors are used in some HEV-drive vehicles (Figure 6-21).

Control of the stator is by an electronic circuit that switches the current flow as needed to keep the rotor turning. Power transistors that are wired as "H" gates reverse current flow according to the position of the rotor. Motor speed can be controlled by PWM of the driver circuits. Rotor position is usually monitored by the use of Hall-effect sensors. However, rotor



**FIGURE 6-20** Components of a brushless DC motor. The Hall-effect sensor is used to determine rotor position.

The field windings of a brushless motor are also called the stator.

141

## MARGINAL NOTES

These notes add "nice-to-know" information to the discussion. They may include examples or exceptions, or may give the common trade jargon for a component.



## A BIT OF HISTORY

This feature gives the student a sense of the evolution of the automobile. This feature not only contains nice-to-know information, but also should spark some interest in the subject matter.

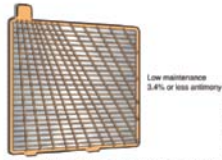


FIGURE 5-14 Low-maintenance battery grid with vertical grid bars intersecting at an angle.

3. Low reserve capacity.
4. Faster discharge by parasitic loads.
5. Shorter life expectancy.

### HYBRID BATTERIES

**AUTHOR'S NOTE:** The following discussion on hybrid batteries refers to a battery type and not to the batteries that are used in hybrid electric vehicles (HEVs).

The hybrid battery combines the advantages of the low-maintenance and maintenance-free battery. The hybrid battery can withstand six deep cycles and still retain 100% of its original reserve capacity. The grid construction of the hybrid battery consists of approximately 2.75% antimony alloy on the positive plates and a calcium alloy on the negative plates. This allows the battery to withstand deep cycling while retaining reserve capacity for improved cranking performance. Also, the use of antimony alloys reduces grid growth and corrosion. The lead calcium has less gassing than conventional batteries.

Grid construction differs from other batteries in that the plates have a lag located near the center of the grid. In addition, the vertical and horizontal grid bars are arranged in a radial pattern (Figure 5-15). By locating the lag near the center of the grid and using the radial grid



### A BIT OF HISTORY

Banks first introduced the storage battery as standard equipment in 1906.

Radial means branching out from a common center.

## AUTHOR'S NOTES

This feature includes simple explanations, stories, or examples of complex topics. These are included to help students understand difficult concepts.

## SUMMARIES

Each chapter concludes with a summary of key points from the chapter. These are designed to help the reader review the chapter contents.

### SUMMARY

- An ammeter is a special meter used to measure current flow in a circuit.
- Electrical noise is an unwanted voltage signal that rides on a signal. Noise is usually the result of radio frequency interference (RFI) or electromagnetic induction (EMI).
- Duty cycle is the percentage of on time the circuit component is turned on as compared to the total time of the cycle.
- A cycle is one set of changes in a signal that repeats itself several times.
- Pulse width is the amount of time, measured in milliseconds, that a component is turned on.
- Frequency is a measure of the number of cycles that occur in one second.
- Hertz is the measurement of frequency.
- A lab scope provides a visual display of electrical waves.
- Glitches may be the result of momentary shorts to ground, shorts to power, or opens in the circuit.
- A sine wave is a waveform that shows voltage-changing polarity from positive to negative.
- Having straight vertical sides and a flat top indicating a fast-acting on-off voltage state identifies a square wave pattern.
- Scan tools interface with the vehicle's computer system to allow the technician to "talk" with the computers.
- The service manual (in either paper form or electronic format) is one of the most important and valuable tools for today's technician.
- The service manual provides information concerning engine identification, service procedures, specifications, and diagnostic information.
- Technical Service Bulletins (TSBs) may provide information concerning fixes for a problem, new part numbers to replace a defective unit, corrections to service manual information, and general information of system operation.
- Service manual procedural information provides the steps necessary to perform the task.
- Since the service manual is divided into several major component areas, a table of contents is provided for easy access to the information.
- Service and parts information can also be provided through computer services.
- Technicians are typically paid according to their abilities. New or apprentice technicians are paid by the hour. Once technicians have demonstrated a satisfactory level of skills, they can go on flat rate.
- When you begin a job, you enter into a business agreement with your employer. When you become an employee, you sell your time, skills, and efforts. In return, your employer pays you for these resources.
- As part of the employment agreement, your employer also has certain responsibilities: instruction and supervision; a clean, safe place to work; wages; fringe benefits; opportunity; and fair treatment.
- Your obligations as an employee to the employer include regular attendance, following directions, responsibility, productivity, and loyalty.
- When communicating with customers, be polite, respectful, organized, and honest.
- An obvious sign of your knowledge and abilities, as well as your dedication to the trade is ASE certification.
- The work order is a contract between the customer and the shop to have specified service performed.
- The true measure of a good technician is an ability to find and correct the cause of problems.
- An obvious sign of your knowledge and abilities, as well as your dedication to the trade is ASE certification.
- The work order is a contract between the customer and the shop to have specified service performed.
- The true measure of a good technician is an ability to find and correct the cause of problems.
- Diagnosis is not guessing, and it is more than following a series of interrelated steps in order to find the solution to a specific problem.

### TERMS TO KNOW

Ammeter  
Average responding  
Backprobe  
Captured signal  
Cycle  
D (Horizontal movement)  
Diagnostic trouble codes (DTCs)  
Digital multimeter (DMM)  
Duty cycle  
Flat rate  
Frequency  
Glitches  
Hertz  
Jumper wire  
Logic probe  
Multimeter  
Noise  
Oscilloscope  
Pulse width  
Rear view square (RMS)  
Scan tool  
Sine wave  
Stray voltage  
Square wave  
Test light  
Voltage drop  
Voltmeter  
Work order

## TERMS TO KNOW LIST

A list of new terms appears next to the Summary.

### TERMS TO KNOW

(continued)

Logic gate  
Low-side driver  
Microprocessor  
Nonvolatile  
Output Driver  
Output Signal  
Program  
Sequential logic circuits  
Sequential sampling  
Servomotor  
Stepper motor  
Voltage

- A servomotor produces rotation of less than a full turn. A feedback mechanism is used to position itself to the exact degree of rotation required.
- A stepper motor contains a permanent magnet armature with two, four, or more field coils. It is used to move the controlled device to whatever location is desired by applying voltage pulses to selected coils of the motor.

### REVIEW QUESTIONS

#### Short-Answer Essays

1. What is binary code?
2. Describe the basics of NOT, AND, and OR logic gate operation.
3. List and describe the four basic functions of the microprocessor.
4. What is the difference between ROM, RAM, and PROM?
5. Explain the differences between analog and digital signals.
6. What is adaptive strategy?
7. Describe the basic function of a stepper motor.
8. Explain the function of a high-side driver.
9. What is the difference between duty cycle and pulse width?
10. What are the purposes of the interface?

#### Fill in the Blanks

1. In binary code, the number 4 is represented by \_\_\_\_\_.

2. The \_\_\_\_\_ is a crystal that electrically vibrates when subjected to current at certain voltage levels.
3. \_\_\_\_\_ are registers designed to store the results of logic operations.
4. The \_\_\_\_\_ is the brain of the computer.
5. \_\_\_\_\_ contains specific data that pertains to the exact vehicle in which the computer is installed.
6. The \_\_\_\_\_ gate reverses binary code.
7. \_\_\_\_\_ drivers complete the actuator control circuit to ground.
8. If a control circuit to an actuator is turned on and off a set amount of cycles per second it is called \_\_\_\_\_.
9. The \_\_\_\_\_ function of the computer holds the program instructions.
10. The input \_\_\_\_\_ converts analog signals to digital signals.

## REVIEW QUESTIONS

Short answer essay, fill-in-the-blank, and multiple-choice questions are found at the end of each chapter. These questions are designed to accurately assess the student's competence in the stated objectives at the beginning of the chapter.



# SHOP MANUAL

To stress the importance of safe work habits, the Shop Manual also dedicates one full chapter to safety. Other important features of this manual include:

## PERFORMANCE-BASED OBJECTIVES

These objectives define the contents of the chapter and define what the student should have learned upon completion of the chapter. These objectives also correspond with the list of required tasks for ASE certification. *Each ASE task is addressed.*

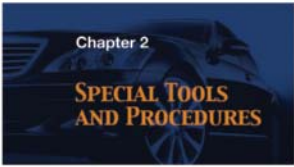
Although this textbook is not designed to simply prepare someone for the certification exams, it is organized around the ASE task list. These tasks are defined generically when the procedure is commonly followed and specifically when the procedure is unique for specific vehicle models. Imported- and domestic-model automobiles and light trucks are included in the procedures.

## SPECIAL TOOLS LISTS

Whenever a special tool is required to complete a task, it is listed in the margin next to the procedure.

## MARGINAL NOTES

These notes add “nice-to-know” information to the discussion. They may include examples or exceptions, or may give the common trade jargon for a component.



**Chapter 2**  
**SPECIAL TOOLS AND PROCEDURES**

**BASIC TOOLS**  
Basic mechanic's tool set

**UPON COMPLETION AND REVIEW OF THIS CHAPTER, YOU SHOULD BE ABLE TO:**

- Explain the proper use of jumper wires.
- Explain the proper use of a test light.
- Explain the proper use of a logic probe.
- Explain the proper use of analog volt/amp/ohmmeters.
- Explain the proper use of digital volt/amp/ohmmeters.
- Describe when to use the different types of multimeters.
- Explain the proper use of a digital storage oscilloscope.
- Use Ohm's law to determine electrical values in different types of circuits.
- Locate service information.
- Explain the concepts of working as an electrical systems technician.

**INTRODUCTION**

This chapter covers some of the typical shop procedures that the electrical systems technician may encounter. This includes proper troubleshooting procedures, the use of special test equipment, the use of service information, and workplace practices.

To be able to properly diagnose electrical components and circuits, you must be able to use many different types of electrical test equipment. In this chapter, you will learn when and how to use the most common types of test equipment. You will also learn which test instrument is best to use to identify the cause of the various types of electrical problems.

Electrical current is a term used to describe the movement or flow of electricity. The greater number of electrons flowing past a given point in a given amount of time, the more current the circuit has. This current, like the flow of water or any other substance, can be measured. The unit for measuring electrical current is the ampere. The instrument used to measure electrical current flow in a circuit is called an **ammeter**.

When any substance flows, it meets resistance. The resistance to electrical flow can be measured. The resistance to current flow produces heat. This heat can be measured to determine the amount of resistance. A unit of measured resistance is called an ohm. Resistance can be measured by an instrument called an **ohmmeter**.

**Classroom Manual**  
Chapter 2, page 20

## BASIC TOOLS LISTS

Each chapter begins with a list of the basic tools needed to perform the tasks included in the chapter.

a series of dashed lines. If the meter displays >30 V, then there is voltage greater than 30 volts in the circuit and the test meter will not perform the insulation test. Push and hold the “TEST” button on the red insulation test lead. While the test is in progress, the applied voltage will be displayed in the lower right corner on the screen and the resistance in M ohms or G ohms will be displayed in the center of the screen. Leave the test leads attached to the circuit and release the “TEST” button. The meter will continue to display the resistance reading while the circuit is discharged through the meter.

### LAB SCOPES AND OSCILLOSCOPES

An oscilloscope is a visual voltmeter (Figure 2-24). For many years, technicians have used scopes to diagnose ignition, fuel injection, and charging systems. These scopes, called “tune-up scopes,” were normally part of a large diagnostic machine, although some were stand-alone units. In recent years, an electronic scope, referred to as a lab scope, has become the diagnostic tool of choice for many good technicians.

The oscilloscope is very useful in diagnosing many electrical problems quickly and accurately. Digital and analog voltmeters do not react fast enough to read systems that cycle quickly. The oscilloscope may be considered as a very fast-reacting voltmeter that reads and displays voltages. The scope allows the technician to view voltage over time (Figure 2-25). These voltage readings appear as a voltage trace on the oscilloscope screen.

An upward movement of the voltage trace on an oscilloscope screen indicates an increase in voltage, and a downward movement of this trace represents a decrease in voltage. As the

Oscilloscopes are commonly called scopes.



**SPECIAL TOOLS**  
Lab scope

The squares formed by the grid are called major divisions. These are further defined by smaller divisions called minor divisions.

**PHOTO SEQUENCE 17**

**TYPICAL PROCEDURE FOR SCAN TESTER DIAGNOSIS**



**PI7-1** Turn the ignition switch to the OFF position.



**PI7-2** Install the proper module into the scan tool.



**PI7-3** If required, connect the scan tester power cables to the vehicle's battery terminals, observing polarity.



**PI7-4** Enter the model year and the VIN number code in the scan tester.



**PI7-5** Select the proper scan tool cable for the vehicle being tested.



**PI7-6** Connect the scan tester cable to the DLC and turn the ignition switch to RUN.



**PI7-7** Select the BODY function and retrieve the DTCs with the scan tester.



**PI7-8** Operate the system being diagnosed and obtain the input sensor and output actuator data with the scan tool.



**PI7-9** Compare the input sensor and output actuator data to specifications in the appropriate service information. Determine data that is not written specifications.

**367**

## PHOTO SEQUENCES

Many procedures are illustrated in detailed Photo Sequences. These detailed photographs show the students what to expect when they perform particular procedures. They also can provide the student a familiarity with a system or type of equipment, which the school may not have.

## CAUTIONS AND WARNINGS

Throughout the text, warnings are given to alert the reader to potentially hazardous materials or unsafe conditions. Cautions are given to advise the student of things that can go wrong if instructions are not followed or if a nonacceptable part or tool is used.

**WARNING:** The tester manufacturer's and vehicle manufacturer's recommended scan tester diagnostic procedures must be followed while diagnosing computer systems. Improper test procedures may result in scan tester damage and computer system damage.

**CAUTION:** Always keep scan tester leads away from rotating parts such as belts and fan blades. Personal injury or property damage may result if scan tester leads become tangled in rotating parts.

The advantages offered by the use of a scan tool include:

1. A scan tester provides quick access to data from various on-board computers. Some vehicles have several diagnostic link connectors (DLCs) to which the scan tester must be connected to access data from a specific computer. For example, some vehicles have separate DLCs to access the powertrain control module (PCM) and antilock brake system (ABS) computer data. Vehicles that have on-board diagnostic (OBD II) systems have a central DLC and data links from the various on-board computers to this DLC. Accessing this computer data greatly reduces diagnostic time.
2. A wide variety of modules are available for many scan testers. These modules allow the same scan tester to display data from many vehicles, including imported vehicles. Some scan tester modules access service bulletin information related to engine and transmission problems. This information is available in a book published by the scan tester manufacturer.
3. The vehicle can be driven on a road test with the scan tester connected to the DLC. This allows the technician to observe computer data during various operating conditions when a specific problem may occur. Most scan testers have a snapshot capability which freezes computer data into the scan tester memory for a specific period of time. This data may be played back after the technician returns to the shop.
4. Most scan testers can be connected to a printer and a copy of the scan tester data can be printed. This allows improved communication between the customer, service writer, and the technician.
5. A scan tester can be connected to a personal computer (PC). This connection allows data to be transferred from the scan tester to the PC. This data may be saved and recalled at a

## CUSTOMER CARE

This feature highlights those little things a technician can do or say to enhance customer relations.

### DIODE PATTERN TESTING

**CUSTOMER CARE:** It is good practice to check the diode pattern of the AC generator anytime an electronic component fails. Because the electronics of the vehicle cannot accept AC current, the damage to the replaced component could have been the result of a bad diode. By performing this check, it is possible to find the cause of the problem.

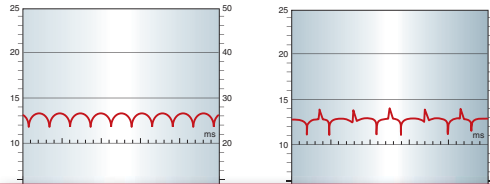
Set an oscilloscope on the lowest scale available. Connect the primary test leads on the AC generator output terminal and ground. Start the engine and place a moderate load on the charging system (15 to 20 amperes). Different patterns may appear. What is considered normal depends on the load placed on the system.

The diode pattern (Figure 7-17) illustrates a good pattern if the AC generator is under a full load. The pattern shown in Figure 7-18 is a good pattern for some AC generators under a no-load condition.

Patterns that have high-resistance, open, and shorted diodes are illustrated (Figures 7-19 through 7-22). Remember to check the waveforms for noise. If the diodes don't rectify all of the AC voltage, some will ride on the DC output.

An alternate method to test the action and functionality of the diodes is to check for AC voltage at the output terminal of the generator. This can be done with a DMM or a lab scope set on a low AC voltage scale. Connect the positive test lead to the generator's output terminal and the negative test lead to the case of the generator. With the engine running, turn on enough accessories to cause a 10 to 20 amp flow from the generator. Ideally there should be zero volts AC displayed on the meter. A voltage reading greater than 0.250 VAC indicates the diodes are not rectifying the AC output of the generator.

The DMM testing just described looks at the average of the three stator windings. Because of this, if one leg of the stator is beginning to have a problem it may not be indicated by the



**Classroom Manual**  
Chapter 7, page 174

**SPECIAL TOOLS**  
Oscilloscope  
Carbon pile  
DMM



**SERVICE TIP:** Instead of using a carbon pile, it is possible to place a moderate load on the charging system by turning on the headlights and a few other electrical accessories.

65

## CROSS-REFERENCES TO THE CLASSROOM MANUAL

Reference to the appropriate page in the Classroom Manual is given whenever necessary. Although the chapters of the two manuals are synchronized, material covered in other chapters of the Classroom Manual may be fundamental to the topic discussed in the Shop Manual.

## SERVICE TIPS

Whenever a short-cut or special procedure is appropriate, it is described in the text. These tips are generally those things commonly done by experienced technicians.

## JOB SHEETS

Located at the end of each chapter, the Job Sheets provide a format for students to perform procedures covered in the chapter. A reference to the ASE task addressed by the procedure is included on the Job Sheet.

### JOB SHEET 56

Name \_\_\_\_\_ Date \_\_\_\_\_

#### TESTING THE WINDSHIELD WASHER CIRCUIT

Upon completion of this job sheet, you should be able to diagnose problems in the windshield washer circuit.

##### ASE Correlation

This job sheet is related to the ASE Electrical/Electronic System Certification Exam's content area: *Horn and Wiper/Washer Diagnosis and Repair*; task: Diagnose the cause of constant, intermittent, or no operation of windshield washer.

##### Tools and Materials

A vehicle  
Wiring diagram for the chosen vehicle  
A DMM  
Hand tools

##### Describe the vehicle being worked on:

Year \_\_\_\_\_ Make \_\_\_\_\_ Model \_\_\_\_\_  
VIN \_\_\_\_\_ Engine type and size \_\_\_\_\_

##### Procedure

1. Describe the general operation of the windshield wipers. Task Completed
2. Check the fluid level in the washer fluid reservoir. Replenish the level, if necessary.
3. Remove the fluid output line from the washer pump. Activate the washer pump. Does fluid come out of the pump? \_\_\_\_\_  
What are your conclusions from this?  
\_\_\_\_\_

623

## CASE STUDIES

Case Studies concentrate on the ability to properly diagnose the systems. Beginning with Chapter 3, each chapter ends with a case study in which a vehicle has a problem, and the logic used by a technician to solve the problem is explained.

## ASE-STYLE REVIEW QUESTIONS

Each chapter contains ASE-style review questions that reflect the performance-based objectives listed at the beginning of the chapter. These questions can be used to review the chapter as well as to prepare for the ASE certification exam.

## ASE PRACTICE EXAMINATION

A 50-question ASE practice exam, located in the Appendix A, is included to test students on the contents of the Shop Manual.

### CASE STUDY

A customer complains that his vehicle's engine "dies" and requires a jump-start. The engine will run for a few minutes, then die again. If the headlights are turned on while the engine is running, the engine dies immediately.

The technician boost starts the engine to confirm the customer's complaint. The engine dies just as reported. The technician slow charges the battery to full capacity. Next, a full battery test series is performed. The battery passes all tests.

The technician then performs a visual inspection of the charging system. During this check, a worn and glazed AC generator drive belt is discovered. The technician does not know for certain yet if the belt is the only problem. However, the charging system tests will not be accurate if the belt is worn. The customer

is informed of what the technician has found thus far, and that other tests will still need to be performed to confirm any other problems. The technician gives the customer an estimate for the belt and receives permission to replace it.

After the new belt is installed, the technician performs the voltage output test and the current output test. The requirement test is also performed to confirm that the correct size AC generator is installed. The technician also checks the diode pattern. The charging system passes all tests.

The customer is notified that the car is ready to be picked up. When the customer arrives, the technician tactfully reminds the customer that all belts should be checked every 6 months and replaced per the manufacturer's maintenance schedule.

### TERMS TO KNOW

Current output test  
Diode/stator test  
Field current draw test  
Full field test  
Full fielding  
Multiplying coil  
Voltage drop test  
Voltage output test

## TERMS TO KNOW LIST

Terms in this list can be found in the Glossary at the end of the manual.

### ASE-STYLE REVIEW QUESTIONS

- Charging system testing is being discussed. *Technician A* says before attempting to test the charging system, the battery must be checked. *Technician B* says the state of charge of the battery is not a concern to charging system testing. Who is correct?  
A. A only C. Both A and B  
B. B only D. Neither A nor B
- AC generator noise complaints are being discussed. *Technician A* says a loose belt will make a grumbling noise. *Technician B* says a whining noise can be caused by a
- Technician A* says the no-load/load voltage output test is used to make a quick determination concerning whether or not the charging system is working properly. *Technician B* says when testing a charging system, the first step is to perform a visual inspection and preliminary checks of the charging system. Who is correct?  
A. A only C. Both A and B  
B. B only D. Neither A nor B
- Test results of the voltage output test are being discussed. *Technician A* says if the charging voltage is too high, there may be a loose or glazed drive belt. *Technician B* says if the charging voltage is too low, the fault might be a grounded field wire from the

### ASE CHALLENGE QUESTIONS

- Charging a battery with a battery charger is being discussed. *Technician A* says that battery-charging voltage should never exceed 15 volts. *Technician B* says that a battery can be considered fully charged when its open circuit voltage exceeds 12.1 volts after it has been stabilized. Who is correct?  
A. Technician A C. Both A and B  
B. Technician B D. Neither A nor B
- Technician A* says that a battery terminal test is performed by placing voltmeter leads between the positive battery post and the negative battery terminal. *Technician B* says that the total amount of voltage drop between the negative battery post and the negative battery terminal should not exceed 300 mV. Who is correct?  
A. Technician A C. Both A and B  
B. Technician B D. Neither A nor B
- Technician A* says that an ammeter is used when performing a battery leakage test. *Technician B* says that a fully charged battery will have a specific gravity of at least 1.265. Who is correct?  
A. Technician A C. Both A and B  
B. Technician B D. Neither A nor B
- Technician A* says that the 3-minute charge test is performed after a battery has failed a capacity test. *Technician B* says that if battery voltage is below 15.5 volts at the end of the 3-minute charge test the battery is probably sulfated. Who is correct?  
A. Technician A C. Both A and B  
B. Technician B D. Neither A nor B
- The battery current drain test is being discussed. *Technician A* says that an ammeter that can read as low as 20 mA should be used. *Technician B* says that a current drain caused by an internally shorted battery could not be measured with an ammeter. Who is correct?  
A. Technician A C. Both A and B  
B. Technician B D. Neither A nor B

299

## ASE CHALLENGE QUESTIONS

Each technical chapter ends with five ASE challenge questions. These are not more review questions; rather, they test the students' ability to apply general knowledge to the contents of the chapter.

### APPENDIX A

### ASE PRACTICE EXAMINATION

- The current draw of a window motor is being measured. *Technician A* says the ammeter can be connected on the power supply side of the motor. *Technician B* says the ammeter can be connected on the ground side of the motor. Who is correct?  
A. A only C. Both A and B  
B. B only D. Neither A nor B
- The digital readout of an auto-ranging DVOM that is in the "volts" position displays "13.7". Which of the following statements is true about this measurement?  
A. The actual value is 13.7 V.  
B. The actual value is 137 mV.  
C. The actual value is 137 mV.  
D. More information is needed in order to determine the actual value.
- A voltmeter that is connected across the input and output terminals of an instrument cluster illumination lamp rheostat indicates 12.6 volts with the switch in the maximum brightness position and the engine off. Which of the following statements is true?  
A. The voltage available at the lamps will be about 12.6 volts.  
B. The voltage available at the lamps will be 0.0 volts.  
C. The rheostat is operating correctly.  
D. More information is needed in order to determine whether the lamps will operate correctly.
- An analog voltmeter is indicating 0.45 volt. Which of the following represents this measurement?  
A. 0.450 mV  
B. 450 mV  
C. 45 mV  
D. 0.045 V
- The following information about a fuel injector control signal has been gathered using a lab scope: Frequency is 10 Hz and pulse width is 5 ms. *Technician A* says this means that the injector is being turned on and off 10 times per second and that the length of time the injector is open during each "on" pulse is 5 ms. *Technician B* says this means that the injector is being turned on and off 10 times per second and that the length of time the injector is closed during each "off" cycle is 95 ms. Who is correct?  
A. A only C. Both A and B  
B. B only D. Neither A nor B
- Oscilloscope testing is being discussed. *Technician A* says the preferred method to use when observing the output of a potentiometer is to select an external trigger. *Technician B* says, when analyzing the output of a low-voltage computer input sensor, a high trigger level should be selected. Who is correct?  
A. A only C. Both A and B  
B. B only D. Neither A nor B
- The left-rear and right-rear taillights and the left-rear brake light of a vehicle turn on dimly whenever the brake pedal is depressed, however, the right-rear brake light operates at the correct brightness. *Technician A* says the left-rear taillight and brake light may have a poor ground connection. *Technician B* says the headlight switch may have excessive resistance. Who is correct?  
A. A only C. Both A and B  
B. B only D. Neither A nor B

589

## SUPPLEMENTS

---

### INSTRUCTOR RESOURCES

The Instructor Resources DVD is a robust ancillary that contains all preparation tools to meet any instructor's classroom needs. It includes chapter outlines in PowerPoint with images, video clips and animations that coincide with each chapter's content coverage, chapter tests in ExamView with hundreds of test questions, a searchable Image Library with all photos and illustrations from the text, theory-based Worksheets in Word that provide homework or in-class assignments, the Job Sheets from the Shop Manual in Word, a NATEF correlation chart, and an Instructor's Guide in electronic format.

### WEBTUTOR ADVANTAGE

Newly available for this title and to the Today's Technician™ Series is the *WebTutor Advantage*, for Blackboard and Angel online course management systems. The *WebTutor for Today's Technician: Automotive Electricity & Electronics, 5e* will include PowerPoint presentations with images and animations, end-of-chapter review questions, pre-tests and post-tests, worksheets, discussion springboard topics, Job Sheets, and more. The *WebTutor* is designed to enhance the classroom and shop experience, engage students, and help them prepare for ASE certification exams.

## REVIEWERS

---

The author and publisher would like to extend a special thanks to the following instructors for their contributions to this text:

**Timothy Belt**

University of Northwestern Ohio  
Lima, OH

**Jason Daniels**

University of Northwestern Ohio  
Lima, OH

**Kevin Fletcher**

Asheville-Buncombe Technical Community  
College  
Asheville, NC

**Jose Gonzalez**

Automotive Training Center  
Exton, PA

**Jack D. Larmor**

Baker College  
Flint, MI

**David Tapley**

University of Northwestern Ohio  
Lima, OH

**Omar Trinidad**

S. Illinois University Carbondale  
Carbondale, IL

**David Young**

University of Northwestern Ohio  
Lima, OH



# Chapter 1

## SAFETY

### UPON COMPLETION AND REVIEW OF THIS CHAPTER, YOU SHOULD BE ABLE TO:

- Explain how safety is a part of professionalism.
- List and describe personal safety responsibilities.
- List the different types of eye protection devices and explain the proper application of each.
- Lift heavy objects properly.
- Inspect power tools before use.
- Raise a vehicle using a floor jack and safety stands.
- Raise a vehicle using a hoist.
- Demonstrate the ability to properly run the engine in the shop.
- Classify fires and fire extinguishers.
- Locate, identify, and inspect fire extinguishers in the shop.
- Explain the proper use of the fire extinguisher.
- Define hazardous materials.
- Explain the right-to-know law or workplace hazardous materials information systems (WHMIS).
- Describe the responsibilities of the employer and the employee concerning hazardous materials.
- Determine what constitutes hazardous waste and how to properly dispose of it.
- Describe the basic safety rules of servicing electrical systems.
- Work around batteries safely.
- Explain the safety precautions associated with charging and starting systems.
- List the safety precautions associated with servicing the air bag system.
- Explain the safety precautions that are necessary when servicing the antilock brake system.
- Explain the safety precautions necessary when servicing hybrid electric vehicles (HEVs).

### INTRODUCTION

Being a professional technician is more than being knowledgeable about automotive systems, it is also an attitude. Being a professional technician includes having an understanding of all the hazards that may exist in the workplace. One of the most obvious traits of a professional is the ability to work productively and safely. This is where knowledge becomes very important. You need it to be productive and you need it to ensure your own safety and the safety of others. This chapter discusses the safety concerns associated with working in an automotive repair shop and the safety concerns associated with the vehicle's fuel and emission systems. In addition to basic shop safety, working on the vehicle's fuel and emission systems presents many special concerns.

Safety is everyone's business. However, never assume the person working next to you is as conscientious as you are. You must be aware of what is going on around you at all times. As a professional technician, you must perform your work in a manner that protects not only you but others in the workplace as well.

## PERSONAL SAFETY

Personal safety encompasses all aspects of preventing injury, including awareness, attitudes, and dress. All three of these are manifested through neat work habits. Cleaning up spills, keeping tools clean, and organizing the tools and materials in the shop all help to prevent accidents. Rushing to complete a job may result in a lack of consideration for personal safety and may ultimately cause an accident. Taking time to be neat and safe is rewarded by fewer accidents, higher customer satisfaction, and better pay.

### Dress and Appearance

Nothing displays professional pride and a positive attitude more than the way you dress (Figure 1-1). Customers demand a professional atmosphere in the service shop. Your appearance instills customer confidence, as well as expresses your attitude toward safety. Wearing proper and neat clothing can prevent injuries.

Loose-fitting clothing, or clothing that hangs out freely, can cause serious injury. Long-sleeve shirts should have their cuffs buttoned or rolled up tightly. Shirrtails should be tucked in at all times. Some job positions within an automotive repair facility may require the employee to wear a necktie. If a necktie is worn in the shop area, it should be tucked inside your shirt. Clip-on ties are recommended if you must wear a tie.

Long hair is a serious safety concern. Very serious injury can result if hair becomes caught in rotating machinery, fan belts, or fans. If your hair is long enough to touch the bottom of your shirt collar, it should be tied back and tucked under a hat.

Jewelry has no place in the automotive shop. Rings, watches, bracelets, necklaces, earrings, and so forth can cause serious injury. The gold, silver, and other metals used in jewelry are excellent **conductors** of electricity. Your body is also a good conductor. When electrical current flows through a conductor, it generates heat. The heat can be great enough to cause severe burns. Jewelry can also become caught in moving parts, causing serious cuts. Necklaces can cause serious injury or even death if they become caught in moving equipment.

You should wear shoes or boots that will protect your feet in the event that something falls or you stumble into something. It is a good idea to wear safety shoes or boots with steel toes and shanks. Most safety shoes also have slip-resistant soles. Tennis and jogging shoes provide little protection and are not satisfactory footwear in the automotive shop.



© Delmar/Cengage Learning

**FIGURE 1-1** Wearing clean and properly fitting clothes along with proper safety equipment is an indication of how serious you are about safety.



## Smoking, Alcohol, and Drugs in the Shop

Due to the potential hazards, never smoke when working in the shop. A spark from a cigarette or lighter may ignite flammable materials in the workplace. If the shop has designated smoking areas, smoke only in those areas. As a courtesy to your customers, do not smoke in their vehicles. Nonsmokers may not appreciate cigarette odor in their vehicles.

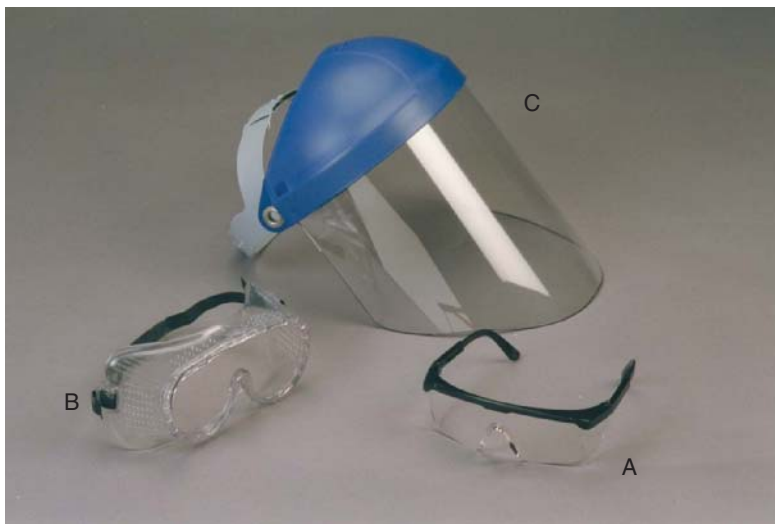
The use of drugs or alcohol must be avoided while working in the shop. Even a small amount of drugs or alcohol affects reaction time. In an emergency situation, slow reaction time may cause personal injury. If a heavy object falls off the workbench and your reaction time is slowed by drugs or alcohol, you may not get out of the way quickly enough to prevent injury. Also you are a hazard to your coworkers if you are not performing at your best.

## Eye Protection

The importance of wearing proper eye protection cannot be overemphasized. Every working day there are more than 1,000 eye injuries. Many of these injuries result in blindness. Almost all of these are preventable. The safest and surest way to protect your eyes is to wear the proper eye protection any time you enter the shop. At a minimum, wear eye protection when grinding, using power tools, hammering, cutting, chiseling, or performing service under the car. In addition, wear eye protection when doing any work that can cause sparks, dirt, or rust to enter your eyes, and when you are working around chemicals. Remember, just because you are not doing the work yourself does not mean you cannot suffer an eye injury. Many eye injuries are caused by a coworker. Wear eye protection any time you are near an eye hazard.

The key to protecting your eyes is the use of *proper* eye protection. Prescription glasses do not provide adequate protection. Regular glasses are designed to impact standards that are far below those that are required in the workplace. The lens may stop a flying object, but the frame may allow the lens to pop out and hit your face, causing injury. In addition, regular glasses do not provide side protection.

There are many types of eye protection (Figure 1-2). One of the best ways to protect your eyes is to wear **occupational safety glasses**. These glasses are light and comfortable. They are constructed of tempered glass or safety plastic lens and have frames that prevent the lens



© Delmar/Cengage Learning

**FIGURE 1-2** Different types of eye protection: (A) safety glasses with side shields; (B) safety goggles that may be worn over prescription glasses; and (C) a face shield that is worn over safety glasses or goggles and protects the face.

from being pushed out upon impact. They have side shields to prevent the entry of objects from the side. Occupational safety glasses are available in prescription lens so they can be worn instead of regular corrective lens glasses.

**Safety goggles** fit snugly around the area of your eyes to prevent the entry of objects and to provide protection from liquid splashes. The force of impact on the lens is distributed throughout the entire area where the safety goggles are in contact with your face and forehead. Safety goggles are designed to fit over regular glasses.

**Face shields** are clear plastic shields that protect the entire face. They are used when there is potential for sparks, flying objects, or splashed liquids, which can cause neck, facial, and eye injuries. The plastic is not as strong or impact resistant as occupational safety glasses or safety goggles. If there is a danger of high-impact objects hitting the face shield, it is a good practice to wear safety glasses under the face shield.

Safety glasses provide little or no protection against chemicals. When working with chemicals, such as battery acid, refrigerants, cleaning solutions, and so forth, safety goggles should be worn. Full-face shields are not intended to provide primary protection for your eyes. They are designed to provide primary protection for your face and neck and should be worn in addition to eye protection.

Before removing your eye protection, close your eyes. Pieces of metal, dirt, or other foreign material may have accumulated on the outside. These could fall into your eyes when you remove your glasses or shield.

## Eyewash Fountains

Eye injuries may occur in various ways in an automotive shop. The following are some common types of eye injuries:

1. Thermal burns from excessive heat.
2. Irradiation burns from excessive light, such as from an arc welder.
3. Chemical burns from strong liquids such as gasoline or battery electrolyte.
4. Foreign material in the eye.
5. Penetration of the eye by a sharp object.
6. A blow from a blunt object.

Wearing safety glasses and observing shop safety rules will prevent most eye accidents. If a chemical gets in your eyes, it must be washed out immediately to prevent a chemical burn. An eyewash fountain is the most effective way to wash the eyes, and every shop should be equipped with some eyewash facility (Figure 1-3). Be sure you know the location of the eyewash fountain in the shop.

## First-aid Kits

First-aid kits should be clearly identified and conveniently located (Figure 1-4). These kits contain such items as bandages and ointment required for minor cuts. All shop personnel must be familiar with the location of first-aid kits. At least one of the shop personnel should have basic first-aid training, and this person should be in charge of administering first aid and keeping first-aid kits filled.

## Hand Protection

Good hand protection is often overlooked. A scrape, cut, or burn can seriously impair your ability to work for many days. A well-fitting pair of heavy work gloves should be worn while grinding, welding, or when handling chemicals or high-temperature components. Special rubber gloves are recommended for handling **caustic** chemicals. Caustic chemicals have the ability to destroy or eat through something and are considered extremely corrosive.

Many technicians wear latex, vinyl, or nitrile gloves to help protect their hands and to keep them clean. These are similar to the type of gloves worn by doctors and dentists during



© Delmar/Cengage Learning

**FIGURE 1-3** An eye wash fountain is used to remove chemicals and dirt from the eyes.



© Delmar/Cengage Learning

**FIGURE 1-4** First-aid kit and typical contents.

examinations. Latex gloves are inexpensive and provide good hand protection, however some people are allergic to latex. If you wear latex gloves and develop a rash or redness on your hands, discontinue use. Vinyl gloves are also available and provide good resistance to tears and many nonaggressive liquids. Also, vinyl gloves are latex-free, so those who are allergic to latex can wear them. At a higher cost, nitrile gloves are latex-free synthetic rubber gloves that are superior to latex or vinyl in puncture resistance. In addition, nitrile gloves resist a wide range of chemicals that are harmful to either latex or vinyl.

Latex, vinyl, or nitrile gloves should be worn if you have an open cut or other injury on your hand, to prevent infection and the spread of diseases. In addition, these gloves should be worn if you are required to render first aid or medical assistance to someone who is injured. Because of the serious nature of blood-borne pathogens (disease- and infection-causing microorganisms carried by blood and other potentially infectious materials), it is important that you take every precaution to protect yourself regardless of the perceived status of the individual you are assisting. In other words, whether or not you think the blood/body fluid is infected with blood-borne pathogens, you treat it as if it is.

## Rotating Belts and Pulleys

Many times the technician must work around rotating parts such as generators, power steering pumps, air pumps, water pumps, and air conditioner (A/C) compressors. Other rotating equipment or components of concern include tire changers, spin balancers, drills, bench grinders, and drive shafts. Always think before acting. Be aware of where you are placing your hands and fingers at all times. Do not place rags, tools, or test equipment near moving parts. In addition, make sure you are not wearing any loose clothing or jewelry that can become caught.

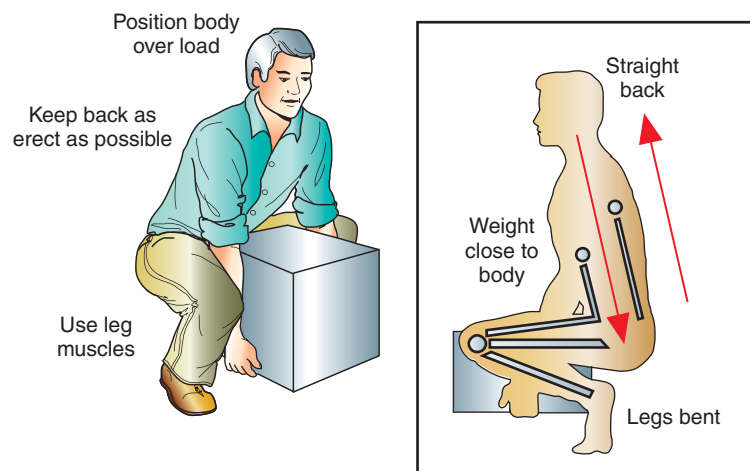
## Electric Cooling Fans

Be very cautious around electric cooling fans. Some of these fans will operate even if the ignition switch is turned off. They are controlled by a temperature-sensing unit in the engine block or radiator and may turn on any time the coolant temperature reaches a certain temperature. Before working on or around an electric cooling fan, you should become familiar with its operation, and, if necessary, you should disconnect the electrical connector to the fan motor or the negative battery cable.

## Lifting

Back injuries are one of the most crippling injuries in the industry, yet most of them are preventable. Most occupational back injuries are caused by improper lifting practices. These injuries can be avoided by following a few simple lifting guidelines:

1. Do not lift a heavy object by yourself. Seek help from someone else.
2. Do not lift more than you can handle. If the object is too heavy, use the proper equipment to lift it.
3. Do not attempt to lift an object if there is not a good way to hold onto it. Study the object to determine the best balance and grip points.
4. Do not lift with your back. Your legs have some of the strongest muscles in your body. Use them.
5. Place your body close to the object. Keep your back and elbows straight (Figure 1-5).
6. Make sure you have a good grip on the object. Do not attempt to readjust the load once you have lifted it. If you are not comfortable with your balance and grip, lower the object and reposition yourself.
7. When lifting, keep the object as close to your body as possible. Keep your back straight and lift with your legs.



**FIGURE 1-5** When lifting a heavy object, keep your back straight and lift with your legs.

© Delmar/Cengage Learning

8. While carrying the object, do not twist your body to change directions. Use your feet to turn your whole body in the new direction.
9. To set the load down, keep the object close to your body. Bend at the knees and keep your back straight. Do not bend forward or twist.
10. If you need to place the object onto a shelf or benchtop, place an edge of the object on the surface and slide it into place. Do not lean forward.

## TOOL AND EQUIPMENT SAFETY

Technicians would not be able to do their job without tools and equipment. Most injuries caused by tools and equipment are the result of improper use, improper maintenance, and/or carelessness.

### Hand Tools

**Hand tools** use only the force generated from the body to operate. They multiply the force received through leverage to accomplish the work. Here are some very simple steps that you can take to help assure safe hand tool use:

1. Do not use tools that are worn out or broken.
2. Do not use a tool to do something that it was not designed to do. Use the proper tool for the job.
3. Keep your tools clean and in good condition.
4. Point sharp edges of tools away from yourself.
5. Do not hold small components in your hands while using tools such as screwdrivers. The tool may slip and cause injury to your hand.
6. Examine your work area for things that can cause injury if a tool slips or a fastener breaks loose quickly. Readjust yourself or the tool to avoid them.
7. Do not put sharp tools in your pockets.

### Power Tool Safety



**WARNING:** Always wear safety glasses when operating a power tool.

**Power tools** use forces other than those generated by the body. They can use compressed air, electricity, or hydraulic pressure to generate and multiply force. Many times a technician will be required to use power tools when performing electrical service. Drills and hole saws will be used to install new accessories onto the vehicle or to drill holes for wiring to pass through. Grinders, drill presses, and hydraulic presses may be used to help fabricate or modify components. **Pneumatic tools** are powered by compressed air and are used to remove or fasten components. All of these tools can cause injury if not used properly. Use the following guidelines when working with power tools:

1. Ask your instructor if you are not sure of the correct operation of a tool.
2. Always wear proper eye protection when using power tools.
3. Check that all safety guards and safety equipment are installed on the tool.
4. Before using an electrical tool, check the condition of the plug and cord. The plug should be a three-prong plug. Never cut off the grounding prong. Do not use the tool if the wires are frayed or broken. Plug the tool only into a grounded receptacle.
5. Before using an air tool, check the condition of the air hose. Do not use the tool if the hose shows signs of weakness such as bulges or fraying. Also, the tool should be properly oiled.
6. Before using a hydraulic tool, check the condition of all hoses and gauges. Do not use the tool if any of these are defective.

**Pneumatic tools** are often called *air tools*.



7. Make sure other people are not in the area when you turn the tool on.
8. Do not leave the area with the tool still running. Stay with the tool until it stops. Then disconnect it.
9. Make all adjustments to the tool before turning it on.
10. If the tool is defective or does not pass your safety inspection, put a sign on it and report it to your supervisor.

## Inspecting Power Tools

Improper use of power tools is the cause of many accidents each year. Many of these could have been avoided if the tool was checked out before it was used.

Use this checklist for the electric power tool(s) that you are inspecting. Do not plug the electrical cord into the socket until the inspection is completed. Consider the following:

1. Name of tool.
2. Is the tool clean?
3. Are safety guards in place?
4. Does the tool appear to be in good condition?
5. Is there a ground terminal on the plug?
6. Is the electrical cord in good condition?

If you answered “no” to any of the previous questions, tag the tool and report the defect to your instructor.

Use this checklist for the pneumatic tool(s) that you are inspecting. Do not connect the tool to the air outlet until the inspection is completed. Consider the following:

1. Name of tool.
2. Is the tool clean?
3. Are safety guards in place?
4. Does the tool appear to be in good condition?
5. Is the air hose in good condition?

If you answered “no” to any of the previous questions, tag the tool and report the defect to your instructor.

## Compressed Air Safety

Compressed air is used in an automotive shop to do many things. However, cleaning off your clothes is not one of them. Dirt and other objects blown off of your clothes can cause serious injury to yourself and others. There may be dirt in the nozzle or hose that will be ejected at a high rate of speed and can be forced into someone’s skin or eyes. In addition, most shops have compressed air systems equipped with automatic oilers. The pressure can push the oil and air bubbles through your skin and into your blood.

Use only approved safety nozzles when using compressed air to dry parts that have been cleaned. Safety nozzles have a relief passage that prevents high pressures from being expelled directly out the front. It is best not to use compressed air to dry parts; however, there are instances where air must be used to dry small passages. In these cases, only use air pressure that has been regulated to about 25 psi.

Check the air hoses for signs of wear. Do not use them if they are bulging, frayed, or if the couplers are damaged.



### SPECIAL TOOLS

Floor jack  
Safety stands  
Wheel blocks  
Service information

## LIFTING THE VEHICLE

Many service procedures require lifting the vehicle. There are two basic methods of lifting the vehicle from the floor: floor jack and safety stands, and hoists. Each requires the technician to follow certain safety rules to prevent injury and vehicle damage.



## Floor Jack and Safety Stand Use

**Floor jacks** are used to lift the vehicle a short distance off the floor or when only a portion of the vehicle needs to be raised (Figure 1-6). Before using a floor jack, check it for signs of hydraulic fluid leaks and for damage that would compromise its safe use. Before lifting the vehicle, place wheel blocks in front of and behind one of the tires that will remain on the ground.

Many jack manufacturers and service information provide illustrations for the proper lift points on a vehicle (Figure 1-7). If this information is not available, always place the floor jack on major strength parts. These areas include the frame, cross member, or differential. If you are in doubt about the proper lift point, ask your instructor. Never lift on sheet metal or plastic parts.

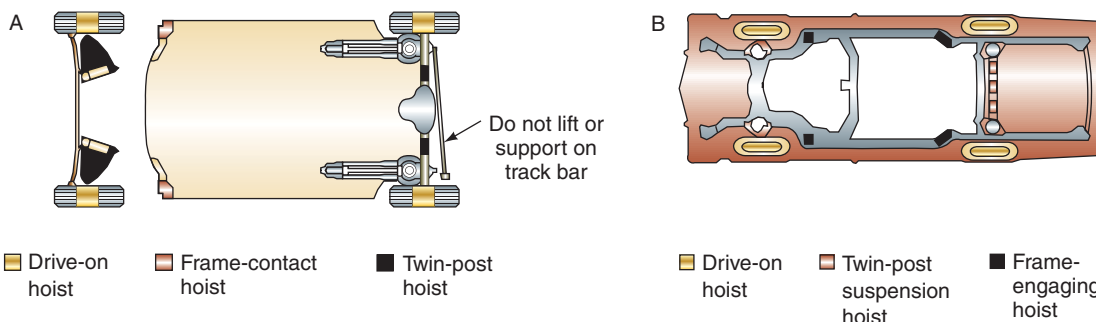
The floor jack is to be used only to lift the vehicle off the floor. It is not intended to support the vehicle while someone is under it. Use **jack stands** to support the vehicle (Figure 1-8). Use one jack stand for each quarter of the vehicle that is lifted (Figure 1-9). Place the jack stand under the frame or a major support component of the vehicle. When the vehicle is lowered onto the stands, make sure that they do not tilt.

**Jack stands** are also referred to as floor stands.



© Delmar/Cengage Learning

**FIGURE 1-6** Floor jacks are used to raise the vehicle a short distance off the floor.



© Delmar/Cengage Learning

**FIGURE 1-7** Examples of proper lift points for (A) unibody and (B) frame/body vehicles.



© Delmar/Cengage Learning

**FIGURE 1-8** Jack stands should be used to support the vehicle after it has been lifted by a floor jack.



© Delmar/Cengage Learning

**FIGURE 1-9** Support the vehicle by jack stands located at each corner that is lifted. Do not rely on the floor jack to support the vehicle.

Before using the floor jack, make sure it has a sufficient rating to lift and sustain the weight of the vehicle. Next, inspect it for proper lubrication and hydraulic fluid level. Check the operation of the jack while looking for signs of hydraulic fluid leaks. If the jack does not pass any one of these inspections, tag it and notify your instructor immediately.

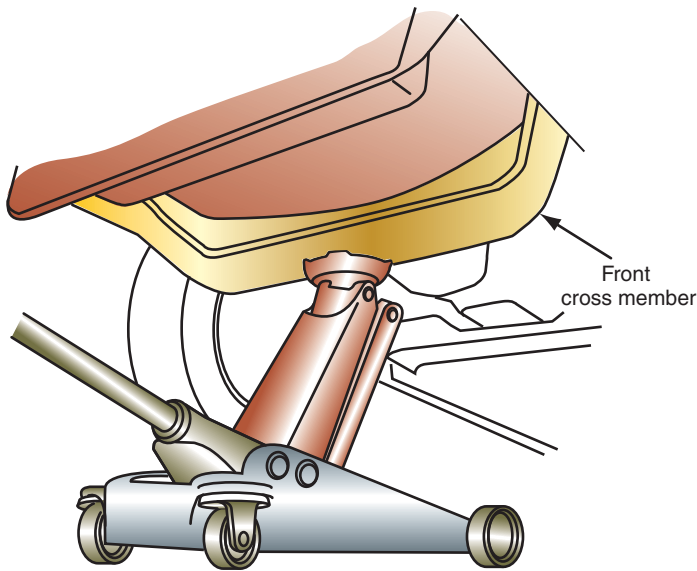
To lift the entire vehicle, begin by placing the vehicle's transmission into PARK. Place it in first gear if the vehicle has a manual transmission. Set the parking brake and place wheel blocks around the rear wheels (Figure 1-10). Position the floor jack under the front of the vehicle at a location strong enough to support the weight. The jack should be centered between the front tires and positioned so that the lift will be straight up and down (Figure 1-11).

Many jack manufacturers and service information provide illustrations for the **vehicle lift points** for the type of vehicle being lifted. Vehicle lift points are the areas the manufacturer recommends for safe vehicle lifting. These areas are structurally strong enough to sustain the stress of lifting. If this information is not available, always place the floor jack on major strength parts. These areas include the frame, cross member, or differential. Never lift on sheet metal or plastic parts.



© Delmar/Cengage Learning

**FIGURE 1-10** Before lifting the vehicle with floor jacks, block the wheels to prevent them from rolling.



**FIGURE 1-11** Correct lifting location for raising the front of the vehicle.

© Delmar/Cengage Learning



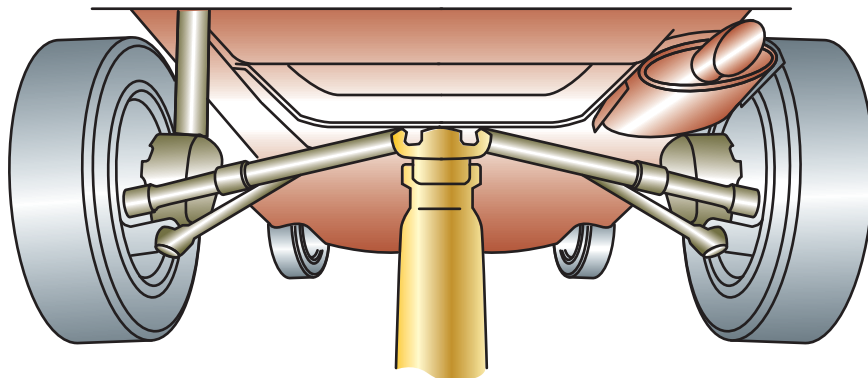
**WARNING:** If you are lifting only one wheel of the vehicle, be careful not to lift it so high that it can slip off of the jack saddle.

Operate the jack until the jack saddle contacts the vehicle lift point. Check for good contact. If things look good, lift the front of the vehicle a couple of inches off of the floor. Recheck the position of the jack. Continue to check the jack position throughout the lifting procedure. If the vehicle or jack begins to lean, lower the jack and reset it. Lift the vehicle to the required height. Do not lift higher than is necessary.

Do not get under a vehicle that is supported only by a floor jack. Place jack stands under the vehicle in locations that will support the weight. Use two safety stands to support the front of the vehicle. Make sure the safety stands are located where they will not lean or slip. Slowly lower the vehicle onto the stands.

Place the floor jack under the rear of the vehicle (Figure 1-12). Follow the same procedure to raise the rear of the vehicle. Use two safety stands to support the rear of the vehicle.

When the vehicle is properly lifted and supported by safety stands, it is safe to work under the vehicle.



**FIGURE 1-12** Proper lift procedure for raising the rear of the vehicle.

© Delmar/Cengage Learning



**CAUTION:**

Never place blocks of wood, and so on, between the vehicle frame and floor jack to obtain additional lift. If additional lift is required, the blocks should be placed under the floor jack.



**CAUTION:**

Some vehicles with fiberglass or composite body structures may require special lifting considerations. Some of these may include opening the doors, deck lid, and hood before lifting. Others may not allow for opening any doors after the vehicle is lifted. Refer to the service information and follow the procedures listed.

Use the same lift points to lower the vehicle. Once one end of the vehicle is on the floor, place wheel blocks around those wheels. Then lower the other end.



## SPECIAL TOOLS

Frame contact hoist  
Service information

## Hoist Safety

**Hoists** are used when the entire vehicle needs to be raised, usually high enough for the technician to stand underneath the vehicle (Figure 1-13). When a vehicle is placed on the hoist, it must be centered. The balance of the vehicle must be taken into consideration, as well as the effects on balance if a heavy component is removed from the vehicle.

Place the hoist pads under proper lift points of the vehicle. It may be necessary to adjust the pad height in order to lift the vehicle level. Stop raising the vehicle when it is a few inches off the floor to confirm good pad contact. Once the vehicle is raised to the desired height, use the hoist's locking mechanism to prevent accidental lowering of the vehicle.

If the vehicle is not level on the pads, or the pads are not in the proper position, lower the vehicle and readjust as needed. Never get under a vehicle that is not sitting properly on the hoist.

Locate the correct lift points in the service information for the vehicle you are working on (Figure 1-14). Other sources of lift point location information include the Automotive Lift Institute and lift manufacturers. Pay close attention to any warnings or special considerations listed there.

Center the vehicle over the hoist; keep in mind the vehicle's center of gravity and balance point. Locate the hoist pads under the lift points (Figure 1-15). Adjust the pads so that the vehicle will be lifted level.

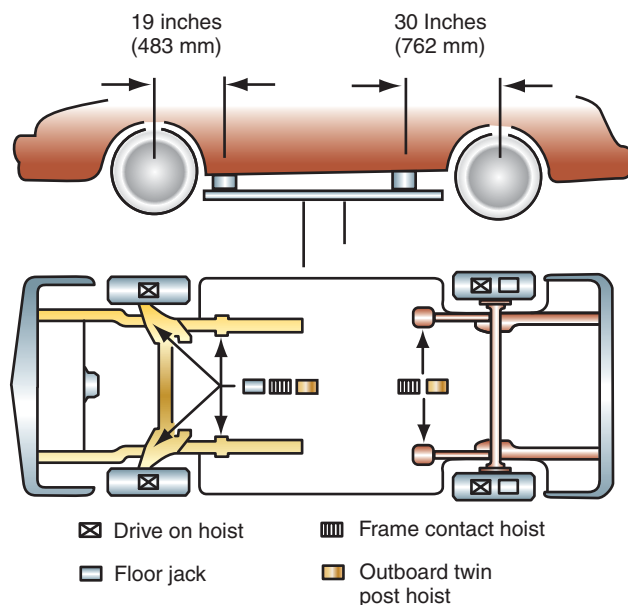
Lift the vehicle a few inches off the floor. Shake the vehicle while observing for signs of any movement. If the vehicle is not secure on the hoist, or unusual noises are heard while lifting, lower it to the floor and reset the pads.

Once the vehicle is at the desired height, lock the hoist. Do not get under the vehicle until the hoist locks have been set.

To lower the vehicle, release the locks and put the control valve into the "lower" position. Once it is returned to the floor, push the contact pads out of the path of the tires.

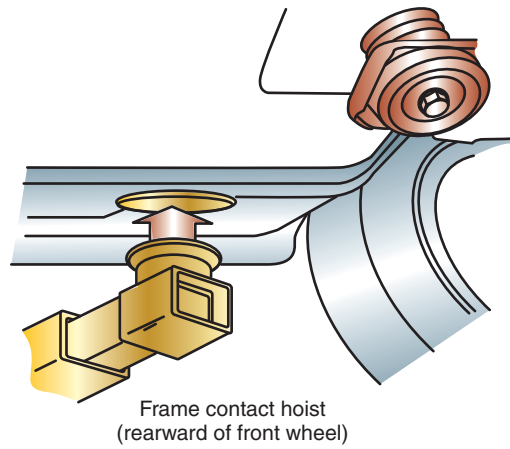


**FIGURE 1-13** One type of hoist that may be used in the automotive shop. The hoist is used to raise the entire vehicle.



**FIGURE 1-14** Lift point illustrations are usually provided in the service information.





© Delmar/Cengage Learning

**FIGURE 1-15** Locate the hoist pad at the correct lift point for the vehicle you are lifting.

## RUNNING THE VEHICLE WHILE IN THE SHOP

Many times it will be necessary to run the engine while the vehicle is in the shop. This presents the possibility of **carbon monoxide** poisoning if it is not done safely. Carbon monoxide is an odorless, colorless, and toxic gas produced as a result of the combustion process. Most shops are equipped with a ventilation system that will remove the vehicle exhaust. If the shop is not equipped with a ventilation system, a hose must be routed from the vehicle's exhaust to outdoors.



**WARNING:** Some of the early warning signs of carbon monoxide poisoning are headaches, dizziness, and blurred vision. If you experience any of these while in the shop, notify your instructor immediately and get some fresh air. If symptoms persist, seek medical attention.

Check the operation of the shop's ventilation system before connecting to the vehicle. Turn on the ventilation motor and place your hand over the hose (Figure 1-16). You should feel a strong, consistent vacuum. A weak vacuum indicates a restriction or a leak in the ventilation system. If you encounter a problem, notify your instructor.

Connect the ventilation hose to the vehicle's exhaust (Figure 1-17). Place wheel blocks around a tire and place the transmission in PARK or NEUTRAL. Set the parking brake. The engine is now ready to be started.



© Delmar/Cengage Learning

**FIGURE 1-16** Testing the ventilation system before using it.



© Delmar/Cengage Learning

**FIGURE 1-17** Connect the ventilation system hose to the vehicle's exhaust before starting the engine. Make sure the hose is secure and there are no kinks in the hose.

Be aware of the warning signs of carbon monoxide poisoning. Report any symptoms to your instructor immediately.



**WARNING:** Be careful when working around electric engine cooling fans. These fans are controlled by a thermostat and can come on without warning, even when the engine is not running. Whenever you must work around these fans, disconnect the electrical connector to the fan motor before reaching into the area around the fan. Make sure you reconnect the connector before you return the car to the customer.

## FIRE HAZARDS AND PREVENTION





Fires are classified by the types of materials that are involved (Table 1-1). Technicians should be able to locate the correct fire extinguisher to control all the types of fire they are likely to experience (Figure 1-18). Technicians must also be able to fight a fire in an emergency.

Labels on the fire extinguisher will indicate the types of fires that it will put out. Become familiar with the use of a fire extinguisher.

### Gasoline

Gasoline is so commonly found in automotive repair shops that its dangers are often forgotten. A slight spark or an increase in heat can cause a fire or explosion. Gasoline is a very explosive liquid and is very powerful. One exploding gallon of gasoline has a force equal to fourteen sticks of dynamite. The expanding vapors from gasoline are extremely dangerous, and these vapors are present even in cold temperatures. Gasoline vapors are heavier than air; therefore, when an open container of gasoline is sitting about, the vapors spill out over the

TABLE 1-1 A guide to fire classification and fire extinguisher types.

Class	Class of Fire	Typical Fuel Involved	Type of Extinguisher
Class  Fires (green)	For Ordinary Combustibles Put out a class A fire by lowering its temperature or by coating the burning combustibles.	Wood Paper Cloth Rubber Plastics Rubbish Upholstery	Multipurpose dry chemical
Class  Fires (red)	For Flammable Liquids Put out a class B fire by smothering it. Use an extinguisher that gives a blanketing, flame-interrupting effect; cover whole flaming liquid surface.	Gasoline Oil Grease Paint Lighter fluid	Carbon dioxide Halogenated agent Standard dry chemical Purple K dry chemical Multipurpose dry chemical
Class  Fires (blue)	For Electrical Equipment Put out a class C fire by shutting off power as quickly as possible and by always using a nonconducting extinguishing agent to prevent electric shock.	Motors Appliances Wiring Fuse boxes Switchboards	Carbon dioxide Halogenated agent Standard dry chemical Purple K dry chemical Multipurpose dry chemical
Class  Fires (yellow)	For Combustible Metals Put out a class D fire of metal chips, turnings, or shavings by smothering or coating with a specially designed extinguishing agent.	Aluminum Magnesium Potassium Sodium Titanium Zirconium	Dry power extinguishers and agents only





© Delmar/Cengage Learning

**FIGURE 1-18** Know the location and types of fire extinguishers that are available in the shop.

sides of the container onto the floor. These fumes are more **flammable** (support combustion) than liquid gasoline and can easily explode.

Never smoke around gasoline since even the droppings of hot ashes can ignite the gasoline. If an engine has a gasoline leak or you have caused a leak by disconnecting a fuel line, stop the leak and clean up the spilled gasoline immediately. While stopping the leak, be extra careful not to cause sparks. If any rags are used in the cleanup of the gasoline, they must be placed in an approved container (Figure 1-19). Due to extreme fire hazards, it is important to immediately clean up any gasoline spilled on the floor. Also, many of the compounds in petroleum are toxic, especially if they are in high concentrations.

The chemicals in petroleum that do not evaporate quickly are biodegradable. Optimum degradation occurs if the gasoline is diluted and there is enough air, water, and nutrients for the microbes to “eat up” the chemicals. These properties of gasoline are an advantage in the cleanup and disposal of small spills. Spreading absorbent material such as kitty litter, sand, ground corncobs, straw, sawdust, woodchips, peat, synthetic absorbent pads, or even dirt can stop the flow and soak up the gasoline. Keep in mind that the absorbent does not make gasoline nonflammable.



© Delmar/Cengage Learning

**FIGURE 1-19** Dirty rags and towels must be stored in approved containers.



© Delmar/Cengage Learning

**FIGURE 1-20** Store any type of combustible materials in an approved safety cabinet.

Brooms can be used to sweep up the absorbent material and put it into buckets, garbage cans, or barrels. Remember to control ignition sources. Be aware of local laws concerning gasoline spills. Some states or municipalities require notification of any gasoline spill larger than 5 gallons.

Gasoline should always be stored in approved containers (Figure 1-20) and never in glass containers. If the glass container is knocked over or dropped, a terrible explosion can occur. Approved gasoline storage cans have a flash-arresting screen at the outlet. These screens prevent external ignition sources from igniting the gasoline within the can while the gasoline is being poured.

Follow these safety precautions regarding gasoline containers:

1. Always use approved gasoline containers that are painted red for proper identification.
2. Do not fill gasoline containers completely. Always leave the level of gasoline at least 1 inch (25 mm) from the top of the container. This action allows expansion of the gasoline at higher temperatures. If gasoline containers are completely full, the gasoline will expand when the temperature increases. This expansion forces gasoline from the can and creates a dangerous spill.
3. If gasoline containers must be stored, place them in a well-ventilated area such as a storage shed. Do not store gasoline containers in your home or in the trunk of a vehicle.
4. When a gasoline container must be transported, be sure it is secured against upsets. Do not transport or fill gasoline containers on plastic truck bed liners. Static electricity can be generated and ignite the vapors.
5. Do not store a partially filled gasoline container for long periods of time because it may give off vapors and produce a potential danger.
6. Never leave gasoline containers open except while filling or pouring gasoline from the container.
7. Do not prime an engine with gasoline while cranking the engine.
8. Never use gasoline as a cleaning agent.

## Diesel Fuel

A **volatile** substance easily vaporizes or explodes. Although diesel fuel is not as volatile as gasoline, it should still be stored and handled in the same way as gasoline. It is also not as refined as gasoline and tends to be a dirty fuel. It normally contains impurities, including

active microscopic organisms that can be highly infectious. If diesel fuel happens to enter an open cut or sore, thoroughly wash it immediately. If it gets into your eyes, flush them immediately and seek medical help.

## Solvents

Cleaning solvents are not as volatile as gasoline, but they are still flammable. They should be treated and stored in the same way as gasoline. Whenever using solvents, wear eye protection.

## Rags

Oily and greasy rags can also cause fires. Used rags should be stored in an approved container and never thrown out with normal trash. Like gasoline, oil is a hydrocarbon and can ignite with or without a spark or flame.

## Fire Extinguisher Use

**Fire extinguishers** are portable apparatuses containing chemicals, water, foam, or special gas that can be discharged to extinguish a small fire. Tour the shop area and become familiar with the location of the fire extinguishers. Use a report sheet to record the locations. Also indicate the type of each extinguisher and what kinds of fires it will extinguish. Check the gauge and record the state of charge for each extinguisher.



**WARNING:** The following is not intended to be used as a lab exercise unless expressly directed by your instructor. Use the photo sequence as a guide to become familiar with fire extinguisher use. You must be willing to fight a fire in the shop, if the occasion arises.



**WARNING:** Do not risk your life fighting a fire. If it is evident that the fire is out of control, get out. Always be aware of where you are and the location of the nearest exit. Do not open garage doors in the event of a fire because the extra oxygen will intensify the flames.

The proper use of a fire extinguisher is very important. It is possible to deplete an extinguisher and still not put out even the smallest of fires if the extinguisher is used improperly. Procedures vary depending on the agents used. Technicians must become familiar with all the extinguishers equipped in the shop. Photo Sequence 1 illustrates the proper use of a multipurpose dry chemical extinguisher. This type of extinguisher is the most widely used in the automotive shop.

## Fire Blankets

A **fire blanket** is a safety device that can be used to extinguish small fires (Figure 1-21). These blankets are made of nonflammable materials such as fiberglass or aramid fibers. Fires that can be put out by a fire blanket include grease/oil fires and electrical fires. Also, fire blankets are useful for putting out clothing fires since they do not stick to fire-damaged skin.

Fire blankets work by preventing the supply of oxygen to a fire. Wrapping something that is burning in a blanket smothers the flames. To get the benefits of your fire blanket, you must use it properly. It is important to read the instructions and become familiar with the proper procedures prior to having to use them in an actual emergency.

When using a fire blanket, you must protect your hands from the fire. Wrap your hands into the top edge of the blanket as you put the blanket on the flame.

# PHOTO SEQUENCE 1

## USING A DRY CHEMICAL FIRE EXTINGUISHER

All photos in this sequence are © Delmar/Cengage Learning.



**P1-1** Multipurpose dry chemical fire extinguisher.



**P1-2** Hold the fire extinguisher in an upright position.



**P1-3** Pull the safety pin from the handle.



**P1-4** Free the hose from its retainer and aim it at the base of the fire.



**P1-5** Stand eight feet from the fire; do not approach any closer to the fire than this distance.



**P1-6** Squeeze the lever while sweeping the hose from side to side. Keep the hose aimed at the base of the fire.



© Delmar/Cengage Learning

**FIGURE 1-21** Fire blanket.



## HAZARDOUS MATERIALS

**Hazardous materials** are materials that can cause illness, injury, or death or pollute water, air, or land. Many solvents and other chemicals used in an automotive shop have warning and caution labels that should be read and understood by everyone who uses them. Many service procedures generate what are known as hazardous wastes. Examples of hazardous waste are used or dirty cleaning solvents and other liquid cleaners.

### Right-to-Know Laws

In the United States, **right-to-know laws** concerning hazardous materials and wastes protect every employee in a workplace. The general intent of these laws is for employers to provide a safe working place as it relates to hazardous materials. The right-to-know laws state that employees have a right to know when the materials they use at work are hazardous. The right-to-know laws started with the **Hazard Communication Standard** published by the Occupational Safety and Health Administration (OSHA) in 1983. This document was originally intended for chemical companies and manufacturers that required employees to handle hazardous materials in their work situation. At the present time, most states have established their own right-to-know laws. Meanwhile, the federal courts have decided to apply these laws to all companies, including automotive service shops.

Under the right-to-know laws, the employer has three responsibilities regarding its employees' handling of hazardous materials. The first responsibility concerns employee training and providing information. All employees must be trained about the types of hazardous materials they will encounter in the workplace. All employees must be informed about their rights under legislation regarding the handling of hazardous materials. In addition, information about each hazardous material must be posted on **material safety data sheets (MSDS)** available from the manufacturer (Figure 1-22). These sheets contain extensive information and facts about hazardous materials. In Canada, MSDS sheets are called **workplace hazardous materials information systems (WHMIS)**.

The employer has a responsibility to place MSDS where they are easily accessible by all employees. The MSDS provide extensive information about the hazardous material such as:

1. Chemical name.
2. Physical characteristics.
3. Protective equipment required for handling.
4. Explosion and fire hazards.
5. Other incompatible materials.
6. Health hazards such as signs and symptoms of exposure, medical conditions aggravated by exposure, and emergency and first-aid procedures.
7. Safe handling precautions.
8. Spill and leak procedures.

The second responsibility of the employer is to make sure that all hazardous materials are properly labeled. The label information must include health, fire, and reactivity hazards posed by the material, as well as the protective equipment necessary to handle the material. The manufacturer must supply all warning and precautionary information about hazardous materials, and this information must be read and understood by the employee before handling the material. Pay great attention to the information on the label. By doing so, you will use the substance in the proper and safe way, thereby preventing hazardous conditions.

The third responsibility of the employer is for maintaining permanent files regarding hazardous materials. These files must include information on hazardous materials in the shop, proof of employee training programs, and information about accidents such as spills or leaks of hazardous materials. The employer's files must also include proof that employees' requests for hazardous material information, such as MSD, have been met. The employer must maintain a general right-to-know compliance procedure manual.



## A BIT OF HISTORY

During the 1960s, disabling injuries increased 20% and 14,000 workers were dying on the job each year. In pressing for prompt passage of workplace safety and health legislation, Senator Harrison A. Williams Jr. called attention to the need to protect workers against such hazards as noise, cotton dust, and asbestos. Representative William A. Steiger also worked for passage of a bill to protect workers. On December 29, 1970, President Richard M. Nixon signed The Occupational Safety and Health Act of 1970, also known as the Williams-Steiger Act.

HEXANE
MSDS Safety Information
Ingredients
Name: HEXANE (N_HEXANE) % Wt: >97 OSHA PEL: 500 PPM ACGIH TLV: 50 PPM EPA Rpt Qty: 1 LB DOT Rpt Qty: 1 LB
Health Hazards Data
LD50 LC50 Mixture: LD50:(ORAL,RAT) 28.7 KG/MG Route Of Entry Inds _ Inhalation: YES Skin: YES Ingestion: YES Carcinogenicity Inds _ NTP: NO IARC: NO OSHA: NO Effects of Exposure: ACUTE:INHALATION AND INGESTION ARE HARMFUL AND MAY BE FATAL. INHALATION AND INGESTION MAY CAUSE HEADACHE, NAUSEA, VOMITING, DIZZINESS, IRRITATION OF RESPIRATORY TRACT, GASTROINTESTINAL IRRITATION AND UNCONSCIOUSNESS. CONTACT W/SKIN AND EYES MAY CAUSE IRRITATION. PROLONGED SKIN MAY RESULT IN DERMATITIS (EFTS OF OVEREXP) Signs And Symptoms Of Overexposure: HLTH HAZ:CHRONIC:MAY INCLUDE CENTRAL NERVOUS SYSTEM DEPRESSION. Medical Cond Aggravated By Exposure: NONE IDENTIFIED. First Aid: CALL A PHYSICIAN. INGEST:DO NOT INDUCE VOMITING. INHAL:REMOVE TO FRESH AIR. IF NOT BREATHING, GIVE ARTIFICIAL RESPIRATION. IF BREATHING IS DIFFICULT, GIVE OXYGEN. EYES:IMMED FLUSH W/PLENTY OF WATER FOR AT LEAST 15 MINS. SKIN:IMMED FLUSH W/P LENTY OF WATER FOR AT LEAST 15 MINS WHILE REMOVING CONTAMD CLTHG & SHOES. WASH CLOTHING BEFORE REUSE.
Handling and Disposal
Spill Release Procedures: WEAR NIOSH/MSHA SCBA & FULL PROT CLTHG. SHUT OFF IGNIT SOURCES:NO FLAMES, SMKNG/FLAMES IN AREA. STOP LEAK IF YOU CAN DO SO W/OUT HARM. USE WATER SPRAY TO REDUCE VAPS. TAKE UP W/SAND OR OTHER NON_COMBUST MATL & PLACE INTO CNTNR FOR LATER (SU PDAT) Neutralizing Agent: NONE SPECIFIED BY MANUFACTURER. Waste Disposal Methods: DISPOSE IN ACCORDANCE WITH ALL APPLICABLE FEDERAL, STATE AND LOCAL ENVIRONMENTAL REGULATIONS. EPA HAZARDOUS WASTE NUMBER:D001 (IGNITABLE WASTE). Handling And Storage Precautions: BOND AND GROUND CONTAINERS WHEN TRANSFERRING LIQUID. KEEP CONTAINER TIGHTLY CLOSED. Other Precautions: USE GENERAL OR LOCAL EXHAUST VENTILATION TO MEET TLVREQUIREMENTS. STORAGE COLOR CODE RED (FLAMMABLE).
Fire and Explosion Hazard Information
Flash Point Method: CC Flash Point Text: 9F, _23C Lower Limits: 1.2% Upper Limits: 77.7% Extinguishing Media: USE ALCOHOL FOAM, DRY CHEMICAL OR CARBON DIOXIDE. (WATER MAY BE INEFFECTIVE.) Fire Fighting Procedures: USE NIOSH/MSHA APPROVED SCBA & FULL PROTECTIVE EQUIPMENT (FP N). Unusual Fire/Explosion Hazard: VAP MAY FORM ALONG SURFS TO DIST IGNIT SOURCES & FLASH BACK. CONT W/STRONG OXIDIZERS MAY CAUSE FIRE. TOX GASES PRDCED MAY INCL:CARBON MONOXIDE, CARBON DIOXIDE.

FIGURE 1-22 An example of a Material Safety Data Sheet (MSDS).

There are responsibilities for the employees as well. Employees must be familiar with the intended purpose of the substance, the recommended protective equipment, accident and spill procedures, and any other information regarding the safe handling of hazardous materials. This training must be given annually to employees and provided to new employees as part of their job orientation.

## Hazardous Waste

Waste is considered hazardous if it is on the Environmental Protection Agency (EPA) list of known and harmful materials or if it has one or more of the following characteristics:

1. Any material that reacts violently with water or other chemicals is considered hazardous. If a material releases cyanide gas, hydrogen sulfide gas, or similar gases when exposed to low-pH acid solutions, it is hazardous.
2. If a material burns the skin or dissolves metals and other materials, it is considered hazardous.



3. Materials are hazardous if they leach one or more of eight heavy metals in concentrations greater than 100 times the primary drinking water standard. These materials are considered toxic.
4. A liquid is hazardous if the temperature at which the vapors on the surface of the fuel will ignite when exposed to an open flame is below 140°F (60°C), and a solid is hazardous if it ignites spontaneously.

A complete list of EPA hazardous wastes can be found in the Code of Federal Regulations. It should be noted that no material is considered hazardous waste until the shop is finished using it and is ready to dispose of it. New oil is not a hazardous waste; however, used oil is. Once you drain oil from an engine, you have generated hazardous waste and now become responsible for its proper disposal. There are many other wastes that need to be handled properly after you have removed them, such as batteries, brake fluid, transmission fluid, and engine coolant.

No fluids drained from a vehicle should be allowed to enter sewage drains. Some fluids, such as coolant, can be captured and recycled in the shop with special equipment. Filters for fluids (transmission, fuel, and oil filters) also need to be handled in designated ways. Used filters need to be drained and then crushed or disposed of in a special shipping barrel. Most regulations demand that oil filters be drained for at least 24 hours before they are disposed of or crushed.

Federal and state laws control the disposal of hazardous waste materials. It is the responsibility of the employer and the employee to ensure that everyone in the shop is familiar with these laws. Hazardous waste disposal laws include the **Resource Conservation and Recovery Act (RCRA)**. This law basically states that hazardous waste generators are responsible for the waste from the time it becomes a waste material until the proper waste disposal is completed. Therefore, the user must store hazardous waste material properly and safely and be responsible for the transportation of this material until it arrives at an approved hazardous waste disposal site where it is processed according to the law. A licensed waste management firm normally does the disposal. The hazardous waste coordinator for the shop should have a written contract with the hazardous waste hauler.

The RCRA controls these types of automotive waste:

1. Paint and body repair products waste.
2. Solvents for parts and equipment cleaning.
3. Batteries and battery acid.
4. Mild acids used for metal cleaning and preparation.
5. Waste oil, engine coolants, or antifreeze.
6. Air-conditioning refrigerants.
7. Engine oil filters.

*NEVER, under any circumstances, use these methods to dispose of hazardous waste material:*

1. Pour hazardous wastes on weeds to kill them.
2. Pour hazardous wastes on gravel streets to prevent dust.
3. Throw hazardous wastes in a dumpster.
4. Dispose of hazardous wastes anywhere but an approved disposal site.
5. Pour hazardous wastes down sewers, toilets, sinks, or floor drains.
6. Bury hazardous wastes in the ground.

## Handling and Disposing Shop Wastes

To assure that you are following the required procedures concerning the handling and disposal of hazardous waste, the following sections are provided as guidelines. Be sure to familiarize yourself with Federal, state, and local regulations in your area.

**Oil Disposal.** Used oils can be recycled, properly disposed, or used to fuel waste oil burners. In all cases, proper collection of used oil is essential. A drip table or screen table is commonly used to collect the oil into a designated collection bucket. These tables will collect oil as it drips off of parts. Be sure not to mix oils unless approved by the recycle company or allowed by the waste oil furnace.

Oil filters must be drained for at least 24 hours before disposal. Once properly drained, they are crushed and then set to be recycled.

Any hazardous waste that is stored on the premises must be properly labeled. Also, be sure to adhere to the regulations as to the maximum quantity that may be stored on site.

**Solvents.** If possible, reduce the use of solvents by utilizing less toxic alternatives. For example, water-based cleaning solvents should be used instead of petroleum-based solvents. Used solvents that have become too dirty to continue their use must be disposed of properly. Usually, this requires a hazardous waste management company to come to the shop on a regular basis and service the equipment. However, some equipment can be serviced in-house. When storing solvents, be sure they are in approved containers and are tightly sealed. Evaporation of the solvent may have an environmental impact.

Properly label used solvent and store it in containment areas. Store solvents with other compatible wastes only.

## Asbestos Exposure

**Asbestos.** describes a number of naturally occurring fibrous materials and is classified as a carcinogen. Asbestos has been identified as a health hazard and has been shown to cause diseases that result in lung cancers known as mesothelioma. When asbestos fibers are breathed in, they cause scarring of the lungs and damage the air passages. The scars result in holding locations for the asbestos fibers that the body is unable to expel. Asbestos has been/is used for clutch discs, brake pads and shoes, and gaskets. Because asbestos is a health hazard, all OSHA and EPA regulations must be adhered to when disposing of parts that contain this material.

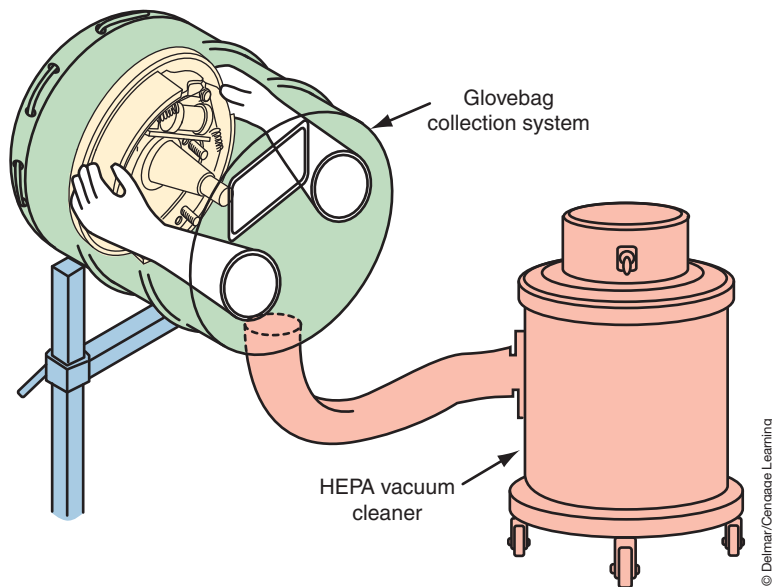
The EPA does not regulate the removal of brake pads and clutches unless more than 50% of the shop's work involves grinding or debonding of the asbestos material. If the shop is above this 50% requirement, then the asbestos materials are regulated as a hazardous waste and must be handled according to the set regulations.

Even if your shop is below the 50% rule, it is very important that as a technician you protect yourself from the dangers associated with inhaling asbestos dust. The EPA recommends that the shop capture asbestos dust into a separate container. The OSHA-preferred method of servicing components consisting of asbestos dust is to use a low-pressure/wet-cleaning method. Never use compressed air to blow off the dust from the parts.

The wet-cleaning method is done by mixing water with an organic solvent. The solvent is flowed over the brake parts prior to removal of the brake drum or around the brake disc prior to brake disassembly. A catch container is positioned to trap the contaminated solvent. During disassembly of the brakes, the solvent is reapplied to assure all asbestos dust is removed.

Another asbestos cleaning method is to use a **high-efficiency particulate-arresting (HEPA)** vacuum cleaner (Figure 1-23). The HEPA vacuum cleaner captures the asbestos dust in a special filter. The brake or clutch parts are covered with a special tent. Built-in gloves in the tent allow the technician to clean the parts while viewing through a window. This procedure prevents direct contact with the asbestos and draws the dust particles into the container.

When the HEPA filter is full, it is wetted with a mist of water and then removed. The filters must be placed into an impermeable container, properly labeled, and properly disposed of in accordance with all laws.



**FIGURE 1-23** A high-efficiency particulate-arresting (HEPA) vacuum cleaner used to capture asbestos fiber dust.

To reduce the risks of asbestos poisoning, the following guidelines should be followed:

- Never smoke while working around asbestos.
- Wash your hands, arms, and face before eating.
- Take showers at the completion of your work shift.
- Do not wear your work clothes home. Change into your work clothes when you arrive at work and change out of them when leaving.

**AUTHOR'S NOTE:** More information concerning work environment safety can be found by contacting the United States EPA Office of Compliance at <http://es.inel.gov> or the Coordinating Committee for Automotive Repair (CCAR)-Greenlink at <http://www.ccar-greenlink.org>.

## ELECTRICAL SYSTEM SAFETY

There are many safety requirements that must be followed when working on the vehicle's electrical system. In addition to personal safety, there is the concern of damaging the electrical system with improper service techniques. The following are a few of the safety rules.

### Battery Safety

Before attempting to do any type of work on or around the battery, you must be aware of certain precautions. To avoid personal injury or property damage, follow these precautions:

1. Battery acid is very corrosive. Do not allow it to come into contact with your skin, eyes, or clothing. If battery acid should get into your eyes, rinse them thoroughly with clean water and seek immediate medical attention. If battery acid comes into contact with your skin, wash with clean water. Baking soda added to the water will neutralize the acid. If the acid is swallowed, drink large quantities of water or milk followed by milk of magnesia and a beaten egg or vegetable oil.
2. When making connections to a battery, be careful to observe polarity, positive to positive and negative to negative.

3. When disconnecting battery cables, always disconnect the negative (ground) cable first.
4. When connecting battery cables, always connect the negative cable last.
5. Avoid any arcing or open flames near a battery. The vapors produced by the cycling of a battery are very explosive. Do not smoke around a battery.
6. Follow the manufacturer's instructions when charging a battery. Charge the battery in a well-ventilated area. Do not connect or disconnect the charger leads while the charger is turned on.
7. Do not add electrolyte to the battery if it is low. Add only distilled water.
8. Do not wear any jewelry while servicing the battery. These items are excellent conductors of electricity. Severe burns may result if current flows through them by accidental contact with the battery positive terminal and a ground.
9. Never lay tools across the battery. They may come into contact with both terminals, shorting out the battery and causing it to explode. This will damage both the tools and the battery.
10. Wear safety glasses and/or a face shield when servicing the battery.

## Starting System Service Safety

Before testing or servicing the starter system, become familiar with these precautions that should be observed:

1. Refer to the recommendations given in the service information for correct procedures for disconnecting a battery. Some vehicles with on-board computers must be supplied with an auxiliary power source to maintain computer memories.
2. Disconnect the battery ground cable before disconnecting any of the starter circuit's wires or removing the starter motor.
3. Be sure the vehicle is properly positioned on the hoist or on safety jack stands.
4. Before performing any cranking test, be sure the vehicle transmission is in park or neutral and the parking brakes are applied. Put wheel blocks in front of and behind one tire.
5. Follow the service information procedures for disabling the ignition system.
6. Be sure all test leads are clear of any moving engine components.
7. Never clean any electrical components in solvent or gasoline. Clean with denatured alcohol, or wipe with clean rags only.

## Charging System Service Safety

The following are some general rules for servicing the generator and the charging system:

1. Do not run the vehicle with the battery disconnected. The battery acts as a buffer and stabilizes any voltage spikes that may cause damage to the vehicle's electronics.
2. When performing charging system tests, do not allow output voltage to increase over 16 volts.
3. If the battery needs to be recharged, disconnect the battery cables while charging.
4. Do not attempt to remove electrical components from the vehicle with the battery connected.
5. Before connecting or disconnecting any electrical connections, the ignition switch must be in the OFF position, unless directed otherwise in the service information.
6. Avoid contact with the BAT terminal of the generator while the battery is connected. BAT is the terminal identifier for the conductor from the generator to the battery positive terminal. Battery voltage is always present at this terminal.

Batteries are very dangerous components of the vehicle. It is important that you be able to demonstrate the ability to work around the battery in a safe manner. Throughout this manual

there will be many instances where you will be required to perform a task involving the battery. Chapter 5 covers the subject of removing and testing the battery. Do not perform any tests or disconnect the battery until you have completed that chapter. The purpose of this section is to assist you in becoming more familiar with the battery to allow you to work safely around it.

Point out the following components of the battery to your instructor:

1. Negative terminal.
2. Positive terminal.
3. Vents.

Answer the following questions concerning battery safety (answer written or orally per your instructor):

1. Why be concerned about battery acid?
2. What should be done if battery acid is splashed into your eyes?
3. What should you do if battery acid gets onto your skin?
4. What is meant by polarity? Why is it a concern when connecting a battery?
5. Which terminal must be disconnected first?
6. When connecting battery cables, which cable is to be connected last?
7. Why is wearing jewelry discouraged around the battery?
8. Why is smoking not allowed around the battery?
9. Why are tools not to be laid across the top of the battery?
10. What safety protection should be worn while servicing or working around the battery?
11. What other safety precautions must be observed?

If you do not understand any of the safety precautions associated with working on or around the battery, ask your instructor.

## Air Bag Safety

The air bag system is designed as a supplemental restraint that, in the case of an accident, will deploy a bag out of the steering wheel or passenger-side dash panel to provide additional protection against head and face injuries. An air bag system demands that the technician pay close attention to safety warnings and precautions when working on or around it. Most air bags are deployed by an explosive charge. Accidental deployment of the air bag can result in serious injury. When working on or around the steering wheel or air bag module, be aware of your hands and arms. Do not place your arm over the module. If the air bag deploys, injury can result.

Air bag systems contain a means of deploying the bag even if the battery is disconnected. This system is needed in the event the battery is damaged or disconnected during an accident. The reserve energy can be stored for over 30 minutes after the battery is disconnected. Follow the service information procedures for disabling the system.

The **air bag module** is the air bag and inflator assembly together in a single package. When carrying the air bag module, carry it so that the bag and trim are facing up and away from your body. In the event of accidental deployment, the charge will be away from you. Do not face the module toward any other people.

When you place the module on the bench, face the bag and trim up. This provides a free space for the bag to expand if it deploys. If the module will be stored for any period of time, it must be stored in a cool dry place. Store the module with the trim up and do not place anything on top of the module.

While troubleshooting the air bag system, do not use electrical testers such as battery-powered or AC-powered voltmeters, ohmmeters, and so on, or any other equipment except those specified in the service information. Do not use a test light to troubleshoot the system.

When it is necessary to make a repair or replace a component in the air bag system, always disconnect the negative battery cable before making the repair. It is a good practice



### CAUTION:

Always double-check the polarity of the battery charger's connections and leads before turning the charger on. Incorrect polarity can damage the battery or cause it to explode.



to insulate the terminal with tape or a rubber hose to prevent it from coming into contact with the battery post. Some manufacturers recommend that the air bag inflator module(s) be disconnected in addition to the negative battery cable.

**AUTHOR'S NOTE:** Be sure to follow all manufacturer's warnings, cautions, and special service notes when working on or around the air bag system.

Although it is unlikely that an air bag module (Figure 1-24) will inflate on its own, it is possible to ignite it while performing service. To prevent injury, be aware of where the module(s) is located in the vehicle. The most common location is in the center of the steering wheel. However, many vehicles also have a passenger-side air bag (Figure 1-25). Some manufacturers are installing air bag systems for the back-seat passengers as well.

**WARNING:** Obey all of the warnings in the service information when working on or around the air bag system. Failure to follow these warnings may result in air bag deployment and injury.

To prevent accidental deployment of the air bag system, disconnect the negative battery cable before disconnecting or connecting any electrical connectors in the system. It is important to be able to recognize the components of the air bag system. Most manufacturers place the wiring of the air bag system into a bright yellow harness tube or use bright yellow insulation (Figure 1-26). The wires are usually tagged to alert the technician. Walk around an air bag-equipped vehicle with your instructor. Your instructor will point out the components of the system and review the necessary safety precautions.

Some manufacturers denote air bag related-circuitry in their service information with a warning symbol (Figure 1-27).

## Antilock Brake System Safety

Antilock brake systems (ABS) automatically pulsate the brakes to prevent wheel lockup under panic stop and poor traction condition. ABS is available on most of today's vehicles. There are many different systems used, and each has its own safety requirements regarding servicing the system. Become familiar with the warnings and cautions associated with the system you are working on by studying the service information before performing any service.

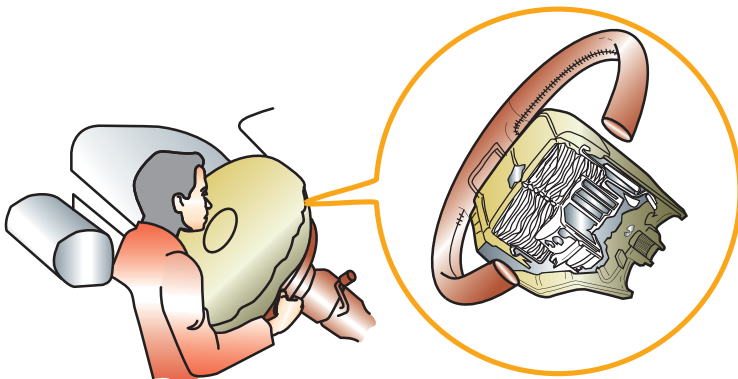
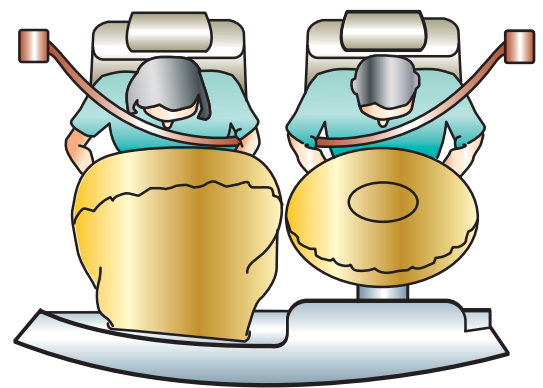


FIGURE 1-24 Typical air bag module.



Passenger side  
(dash mounted)

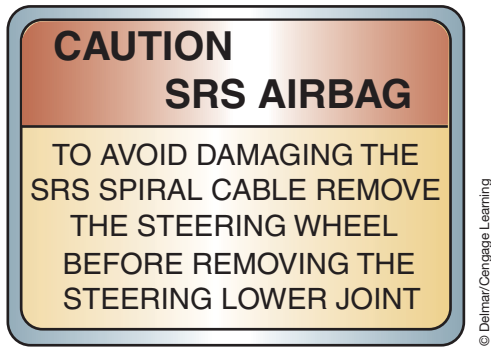
Driver side  
(steering wheel  
mounted)

FIGURE 1-25 An air bag system with both a driver and passenger side air bag module.

© Delmar/Cengage Learning

© Delmar/Cengage Learning





**FIGURE 1-26** The air bag wiring and components are usually identified with a warning label.



**FIGURE 1-27** Some manufacturers identify air bag circuits in their service information with a warning symbol.

Certain components of the ABS are not intended to be serviced individually. Do not attempt to remove or disconnect these components. Only those components with approved removal and installation procedures in the service information should be serviced.

Some operations require that the tubes, hoses, and fittings be disconnected. Many earlier antilock brake systems used high hydraulic pressures and an accumulator to store this pressurized fluid. Before disconnecting any lines or fittings, the accumulator must be fully depressurized. Follow the service information procedures for depressurizing the system.

Many late-model ABS systems do not use an accumulator; therefore these systems do not require depressurizing. However, always refer to the correct service information before servicing a brake system.

Some service operations to the antilock brake system require that the tubes, hoses, and fittings be disconnected. The ABS can use hydraulic pressures as high as 2,800 psi and an accumulator to store this pressurized fluid. Before disconnecting any lines or fittings, the accumulator must be fully depressurized. The following is a common method of depressurizing the ABS. However, follow the service information procedures for the vehicle you are working on.

1. Place the ignition switch in the OFF position.
2. Pump the brake pedal a minimum of 20 times.
3. There should be noticeable change in pedal feel when the accumulator is discharged.

## GENERAL HYBRID ELECTRIC VEHICLE SAFETY

Since the hybrid electric vehicle (HEV) system can use voltages in excess of 300 volts (both DC and AC), it is vital that the service technician be familiar with, and follow, all safety precautions. Failure to perform the correct procedures can result in electrical shock, battery leakage, an explosion, or even death. The following are some general service precautions to be aware of:

- Test the integrity of the insulating grooves prior to use.
- Wear high-voltage insulating gloves when disconnecting the service plug.
- Do not attempt to test or service the system for 5 minutes after the high-voltage service plug is removed. At least 5 minutes is required to discharge the high-voltage capacitors inside the inverter module.
- Never cut the orange high-voltage power cables. The wire harnesses, terminals, and connectors of the high-voltage system are identified by orange. In addition, high voltage components may have a “High Voltage” caution label attached to them.
- Never open high-voltage components.
- Use insulated tools when available.
- Do not wear metallic objects that may cause electrical shorts.
- Follow the service information diagnostic procedures.



### SPECIAL TOOLS

DMM capable of reading 400 VDC  
Insulating gloves  
Insulating tape

- Wear protective safety goggles when inspecting the high-voltage (HV) battery.
- Before touching any of the high-voltage system wires or components, wear insulating gloves, make sure the high voltage service plug is removed, and disconnect the auxiliary battery.
- Remove the service disconnect prior to performing a resistance check.
- Remove the service plug prior to disconnecting or reconnecting any connectors or components.
- Isolate any high-voltage wires that have been removed with insulation tape.
- Properly torque the high-voltage terminals.



**WARNING:** The technician must verify that the system remains powered down when performing any repairs that involve contact with high-voltage or hybrid components or systems.



**WARNING:** The high-voltage check-out procedure must be performed to ensure that the vehicle is properly powered down.



**WARNING:** Whenever the vehicle has been left unattended, recheck that the service disconnect has not been reinstalled.



**WARNING:** Prior to performing any diagnostic or service procedure, you must thoroughly read and follow all applicable high-voltage safety procedures.



**WARNING:** Be sure to utilize the proper safety equipment when working on any high-voltage system. Failure to do so may result in serious or fatal injury.



**WARNING:** Wait a minimum of 5 minutes after performing the high-voltage battery disconnect procedure before accessing the high-voltage system. Failure to do so may result in serious or fatal injury.

When working on an HEV, always assume the HV system is live until you have proven otherwise. If the vehicle has been driven into the service department, you know that the HV system was energized since most HEVs do not move without the HV system operating.

It is critical that the proper tools be used when working on the HV system. These include protective hand tools and a digital multimeter (DMM) with an insulation test function. The meter must be capable of checking for isolation up to 1,000 volts and measuring resistance at over 1.1 mega ohms. In addition, the DMM insulation test function is used to confirm proper isolation of the HV system components after a repair is performed.

Always remove the service disconnect and perform the HV checkout procedure to prove that the HV system has been powered down. Never perform repairs until you have performed this procedure to ensure the system is safe to work on. Follow Photo Sequence 2 as a guide to the safety procedures that must be followed whenever servicing the HEV's high-voltage systems.

Whenever possible use the **one-hand rule** when servicing the HV system (Figure 1-28). The one-hand rule means working with only one hand while servicing the HV system so that in the event of an electric shock the high voltage will not pass through your body. It is important to follow this rule when performing the HV check out procedure since confirmation of HV system power down has not been proven yet.

## HEV HIGH-VOLTAGE ISOLATION

All photos in this sequence are © Delmar/Cengage Learning.



**P2-1** Tools required to perform this procedure include safety goggles, 1000-volt-rated insulating gloves, and a digital multimeter (DMM).



**P2-2** Remove the key from the ignition.



**P2-3** Test the integrity of the insulating gloves prior to use. Wear the gloves until the high-voltage isolation procedure is complete.



**P2-4** Put on your eye protection.



**P2-5** If equipped, disconnect the 12-volt in-line connector to isolate the 12-volt battery. If the vehicle does not have the in-line connector, disconnect the negative (-) terminal of the auxiliary (12-volt) battery. Always disconnect the auxiliary battery prior to removing the high-voltage service plug.



**P2-6** Remove the high-voltage service plug and put it into your tool box or somewhere it cannot be accidentally reinstalled by someone else.



**P2-7** Cover the high-voltage service plug receptacle with insulation tape.



**P2-8** After waiting at least 5 minutes for the high-voltage condenser inside the inverter to discharge, remove any covers necessary to access the isolation test locations.



**P2-9** Use a DMM to confirm that high-voltage circuits have 0V before performing any service procedure.



© Delmar/Cengage Learning

**FIGURE 1-28** Follow the “one-hand” rule while testing the high-voltage system of an HEV.

## Insulated Glove Integrity Test

The isolating gloves that the technician must wear for protection while servicing the HV system must be tested for integrity before they are used. If there is a leak in the gloves, high-voltage electricity can travel through the hole to the technician’s body. The isolating gloves must meet Class “0” requirements of a rating of 1,000 volts (Figure 1-29). In addition, the technician should wear rubber-soled shoes, cotton clothing, and safety glasses with side shields. Remove all jewelry and make sure metal zippers are not exposed. Always have a second set of isolation gloves available and let someone in the shop know their location. When preparing to work on an HEV, let them know in the event they must come to your aid.

To test the isolating gloves:

1. Remove the gloves from leather protectors and inspect for any tears or worn spots.
2. Blow air into the gloves to inflate them and seal the opening by folding the base of the glove.
3. Slowly rotate the base of the glove toward the fingers to increase the pressure (Figure 1-30).
4. Look and feel for pinholes.

Repeat the steps for each glove. This procedure must be performed for each new set of gloves and before each use.



**WARNING:** Do not use the gloves if they fail the leak test or are damaged.



### CAUTION:

Once the high-voltage service plug is removed, do not operate the power switch. Doing so may damage the hybrid vehicle control ECU.

## HIGH-VOLTAGE SERVICE PLUG

The HEV is equipped with a **high-voltage service plug** that disconnects the HV battery from the system. Usually, this plug is located near the battery (Figure 1-31). Prior to disconnecting the high-voltage service plug, the vehicle must be turned off. Some manufacturers also requires that the negative terminal of the auxiliary battery be disconnected. Once the high-voltage service plug is removed, the high-voltage circuit is shut off at the intermediate position of the HV battery.

The high-voltage service plug assembly contains a safety interlock reed switch. The reed switch is opened when the clip on the high-voltage service plug is lifted. The open reed switch





© Delmar/Cengage Learning

**FIGURE 1-29** Class "0" isolation gloves must be worn when working on the high-voltage system.



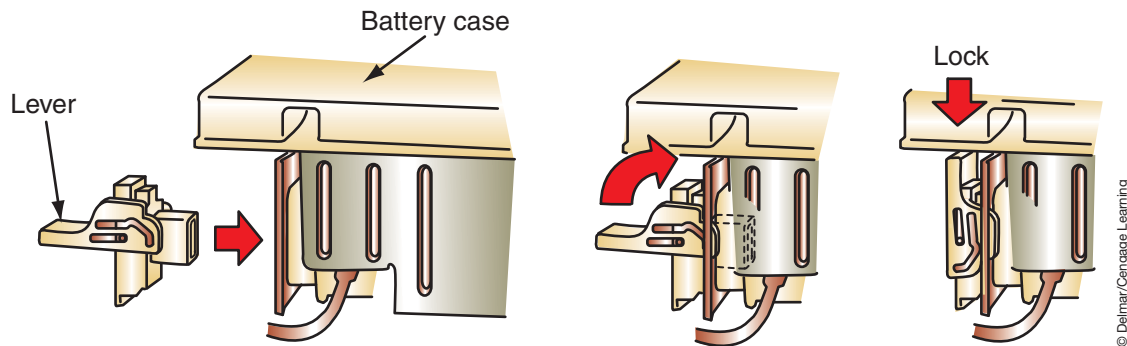
© Delmar/Cengage Learning

**FIGURE 1-30** Test the isolation gloves for leaks before each use.



© Delmar/Cengage Learning

**FIGURE 1-31** The high-voltage service plug is usually located near the HV battery.



**FIGURE 1-32** To install the service plug, make sure the lever is down and then fully locked.

© Delmar/Cengage Learning



### SERVICE TIP:

DTCs will be erased once the batteries are disconnected. Prior to disconnecting the system, be sure to check and record any DTCs.

turns off power to the service main relay (SMR). The main fuse for the high-voltage circuit is inside the high-voltage service plug assembly.

However, never assume that the high-voltage circuits are off. The removal of the high-voltage service plug does not disable the individual high-voltage batteries. Use a DMM to verify that 0 volts are in the system before beginning service. When testing the circuit for voltage, set the voltmeter to the 400 VDC scale.

After the high-voltage service plug is removed, a minimum of five minutes must pass before beginning service on the system. This is required to discharge the high voltage from the condenser in the inverter circuit.

To install the high-voltage service plug, make sure the lever is locked in the DOWN position (Figure 1-32). Slide the plug into the receptacle, and lock it in place by lifting the lever upward. Once it is locked in place, it closes the reed switch.

## TERMS TO KNOW

Air bag module  
 Air bag system  
 Antilock brake systems (ABS)  
 Asbestos  
 BAT  
 Carbon monoxide (CO)  
 Caustic  
 Conductors  
 Face shields  
 Fire blanket  
 Fire extinguishers  
 Flammable  
 Floor jacks  
 Hand tools  
 Hazard Communication Standard  
 Hazardous materials  
 High-efficiency particulate-arresting (HEPA)  
 High-voltage service plug

## SUMMARY

- Being a professional technician means more than having knowledge of vehicle systems. It also requires an understanding of all the hazards in the work area.
- As a professional technician, you should work responsibly to protect yourself and the people around you.
- Technicians must be aware that it is their responsibility to prevent injuries in the shop, and that their actions and attitudes reflect how seriously they accept that responsibility.
- Long-sleeve shirts should have their cuffs buttoned or rolled up tightly, and shirttails should be tucked in at all times. Neckties should be tucked inside your shirt; ideally, only clip-on ties should be worn.
- Long hair should be tied back and tucked under a hat.
- Jewelry has no place in the automotive shop.
- The safest and surest method of protecting your eyes is to wear proper eye protection anytime you enter the shop.
- When working around rotating pulleys and belts, be aware of where you are placing your hands and fingers at all times.
- Most occupational back injuries are caused by improper lifting practices.
- Most injuries caused by tools and equipment are the result of improper use, improper maintenance, and carelessness.
- Never use compressed air for cleaning off your clothes.



## SUMMARY

- The floor jack is to be used only to lift the vehicle off the floor. Use jack stands to support the vehicle after it is lifted.
- Fires are classified by the types of materials involved. Fire extinguishers are classified by the type of fire they will extinguish.
- Batteries can cause serious injury if all safety rules are not followed when working on or around them.
- The air bag system demands that the technician pay close attention to safety warnings and precautions when working on or around them.
- Air bag systems contain a means of deploying the bag even if the battery is disconnected. The reserve energy can be stored for over 30 minutes after the battery is disconnected.
- Since the hybrid system can use voltages in excess of 300 volts (both DC and AC), it is vital that the service technician be familiar with, and follow, all safety precautions.
- Remove the high-voltage service plug and put it where it cannot be accidentally reinstalled by someone else.
- Do not attempt to test or service the high-voltage system of an HEV for five minutes after the high-voltage service plug is removed.
- Use a DMM to confirm that high-voltage circuits have 0V before performing any service procedure on the high-voltage system of an HEV.
- The isolating gloves that are worn to protect the technician while servicing the high-voltage system of an HEV must be tested for integrity before use.
- The HEV is equipped with a high-voltage service plug that disconnects the HV battery from the system.
- Never assume that the high-voltage circuits of an HEV are off.
- Do not use the isolating gloves if they fail the leak test or are otherwise damaged.

## TERMS TO KNOW

(continued)

Hoists  
Jack stands  
Material safety data sheets (MSDS)  
Occupational safety glasses  
One-hand rule  
Pneumatic tools  
Power tools  
Resource Conservation and Recovery Act (RCRA)  
Right-to-know laws  
Safety goggles  
Vehicle lift point  
Volatile  
Workplace hazardous materials information systems (WHMIS)

## ASE-STYLE REVIEW QUESTIONS

1. Which of the following is **not** included in proper lifting practices?
  - A. Do not lift with your back.
  - B. Keep your back and elbows straight.
  - C. Lift the object by yourself so others are out of the way.
  - D. While carrying the object, do not twist your body to change directions.
2. *Technician A* says the right-to-know laws require employers to train employees regarding hazardous waste materials.  
*Technician B* says the right-to-know laws have no provisions requiring proper labeling of hazardous materials.  
Who is correct?
  - A. A only
  - B. B only
  - C. Both A and B
  - D. Neither A nor B
3. All of the following statements concerning hybrid high-voltage system safety are true, EXCEPT
  - A. Disconnect the motor generators prior to turning the ignition off.
  - B. Test the insulating gloves for leaks prior to use.
  - C. Do not attempt to test or service the system for 5 minutes after the high-voltage service plug is removed.
  - D. Turn the power switch to the off position prior to performing a resistance check.
4. *Technician A* says electrical fires are extinguished with Class A fire extinguishers.  
*Technician B* says gasoline is extinguished with Class B fire extinguishers.  
Who is correct?
  - A. A only
  - B. B only
  - C. Both A and B
  - D. Neither A nor B

5. *Technician A* says material safety data sheets (MSDS) explain employers' and employees' responsibilities regarding handling and disposal of hazardous materials.  
*Technician B* says material safety data sheets (MSDS) contain specific information about hazardous materials.  
Who is correct?
- A. A only                      C. Both A and B  
B. B only                      D. Neither A nor B
6. *Technician A* says a solid that ignites spontaneously is considered a hazardous material.  
*Technician B* says a liquid is considered a hazardous material if the vapors on the surface will ignite when exposed to an open flame whose temperature is below 140°F (60°C).  
Who is correct?
- A. A only                      C. Both A and B  
B. B only                      D. Neither A nor B
7. *Technician A* says safety glasses should be worn when working with battery acid and refrigerants.  
*Technician B* says full-face shields are designed to provide protection for the face, neck, and eyes of the technician.  
Who is correct?
- A. A only                      C. Both A and B  
B. B only                      D. Neither A nor B
8. Which of the following statements on HEV safety is correct?
- A. Always place the high-voltage service plug where someone will not accidentally reinstall it.  
B. Use a voltmeter set on 400 VDC to determine if the high-voltage system voltage is at 0 volts before servicing.  
C. Test the integrity of the insulating gloves prior to use.  
D. All of the above.
9. Which of the following statements concerning gasoline storage is true?
- A. Always use approved gasoline containers that are painted blue for proper identification.  
B. Prevent air from entering the container by filling gasoline containers completely full.  
C. Always transport gasoline containers on plastic bed liners.  
D. Do not store a partially filled gasoline container for long periods of time.
10. *Technician A* says once the service plug is disconnected there is no high-voltage in the vehicle systems.  
*Technician B* says prior to disconnecting the high-voltage service plug, the vehicle must be turned off and the auxiliary battery must be disconnected.  
Who is correct?
- A. A only                      C. Both A and B  
B. B only                      D. Neither A nor B

Name \_\_\_\_\_ Date \_\_\_\_\_

## SHOP SAFETY SURVEY

As a professional technician, safety should be one of your first concerns. This job sheet will increase your awareness of shop safety items. As you survey your shop and answer the following questions, you will learn how to evaluate the safety of any workplace.

### Procedure

Task Completed

Your instructor will review your work at each Instructor Response point.

1. Before you begin to evaluate your workplace, evaluate yourself. Are you dressed for work?  Yes  No

If yes, why? \_\_\_\_\_

\_\_\_\_\_

If no, what must you correct to be properly dressed? \_\_\_\_\_

\_\_\_\_\_

2. Are your safety glasses OSHA approved?  Yes  No

Do they have side shields? \_\_\_\_\_

3. Carefully inspect your shop, noting any potential hazards. \_\_\_\_\_

\_\_\_\_\_

**NOTE:** A hazard is not necessarily a safety violation but is an area of which you must be aware.

4. Are there safety areas marked around grinders and other machinery?  Yes  No

5. What is the air pressure in your shop? \_\_\_\_\_

6. Where are the tools stored in your shop? \_\_\_\_\_

\_\_\_\_\_

Are they clean and neatly stored?  Yes  No

7. If you could, how would you improve the tool storage? \_\_\_\_\_

\_\_\_\_\_

\_\_\_\_\_

8. What kind of hoists are used in your shop? \_\_\_\_\_

\_\_\_\_\_

9. Ask your instructor to demonstrate hoist usage. \_\_\_\_\_

Task Completed

- 10. Where is the first-aid kit in your shop? \_\_\_\_\_  
\_\_\_\_\_
- 11. Where is the main power shutoff or emergency shutoff controls located?  
\_\_\_\_\_
- 12. List the location of the exits. \_\_\_\_\_  
\_\_\_\_\_
- 13. Describe the emergency evacuation procedures.  
\_\_\_\_\_  
\_\_\_\_\_  
\_\_\_\_\_
- 14. Where are the hazardous materials stored?  
\_\_\_\_\_  
\_\_\_\_\_  
\_\_\_\_\_
- 15. What is the procedure for handling hazardous waste?  
\_\_\_\_\_  
\_\_\_\_\_  
\_\_\_\_\_
- 16. What is the procedure to be followed in your shop in case of an accident?  
\_\_\_\_\_  
\_\_\_\_\_  
\_\_\_\_\_
- 17. Have your instructor supply you with a vehicle make, model, and year. Using the appropriate shop manual, draw an illustration showing the lifting points on the given vehicle.

Instructor's Response \_\_\_\_\_  
\_\_\_\_\_  
\_\_\_\_\_

Name \_\_\_\_\_ Date \_\_\_\_\_

## FIRE HAZARD INSPECTION

Fire is always a danger in any automotive shop. The very nature of automotive work involves the use of many highly flammable chemicals. Because of this, a technician must be very careful. Watch for and immediately correct all fire hazards.

### Procedure

Task Completed \_\_\_\_\_

1. Are there any flammable liquids stored in your shop? \_\_\_\_\_

Are they stored properly?  Yes  No

Why or why not? \_\_\_\_\_

\_\_\_\_\_

2. Where are the fire extinguishers located in your shop? \_\_\_\_\_

\_\_\_\_\_

Against what class fires can each extinguisher be used? \_\_\_\_\_

\_\_\_\_\_

3. Explain to your instructor how to use each fire extinguisher in your shop.

4. Does your shop have a fire blanket?  Yes  No

If so, where is it kept? \_\_\_\_\_

\_\_\_\_\_

5. Where are the fire alarms located? \_\_\_\_\_

\_\_\_\_\_

6. Where are the fire exits located? \_\_\_\_\_

\_\_\_\_\_

7. Where are the fire escape routes posted? \_\_\_\_\_

\_\_\_\_\_

8. Where are the fireproof cabinets located? \_\_\_\_\_

\_\_\_\_\_

9. Where are dirty shop towels to be disposed? \_\_\_\_\_

\_\_\_\_\_

Instructor's Response \_\_\_\_\_

\_\_\_\_\_

\_\_\_\_\_

*This page intentionally left blank*



Name \_\_\_\_\_ Date \_\_\_\_\_

## HYBRID SAFETY

Upon completion of this job sheet, you should be familiar with the critical safety procedures involved in servicing a high-voltage hybrid system.

### ASE Correlation

This job sheet is related to the ASE Electrical/Electronic System Certification Exam's content area: *General Electrical System Diagnosis*; task: Identify location of hybrid vehicle high-voltage circuit disconnect location and safety procedures.

This job sheet is related to the ASE Electrical/Electronic System Certification Exam's content area: *Battery Diagnosis and Service*; task: Identify high-voltage circuits of electric or hybrid electric vehicle and related safety precautions.

### Tools and Materials

- HEV
- Service information
- Insulating gloves
- Eye protection

### Describe the vehicle being worked on:

Year: \_\_\_\_\_ Make: \_\_\_\_\_ Model: \_\_\_\_\_  
 VIN: \_\_\_\_\_ Engine type and size: \_\_\_\_\_

### Procedure

Task Completed

1. Use the service information data and determine the location on the vehicle for the high-voltage service plug. \_\_\_\_\_  
 \_\_\_\_\_  
 \_\_\_\_\_
2. What must be done prior to disconnecting the service plug?  
 \_\_\_\_\_  
 \_\_\_\_\_
3. How long must you wait after the plug is disconnected before servicing the system?  
 \_\_\_\_\_  
 \_\_\_\_\_
4. Access the 12V auxiliary battery and remove the negative terminal.
5. Test the insulating gloves for leaks. Are the gloves safe to use?  Yes  No  
 If no, inform your instructor.
6. Put on the insulating gloves and eye protection.

---

Task Completed

7. Remove the service plug. What device(s) are integrated into the service plug assembly?

---

---

8. Reinstall the service plug.

9. Review your observations with your instructor.

Instructor's Response \_\_\_\_\_

---

---

# SPECIAL TOOLS AND PROCEDURES



### BASIC TOOLS

Basic mechanic's tool set

### UPON COMPLETION AND REVIEW OF THIS CHAPTER, YOU SHOULD BE ABLE TO:

- Explain the proper use of jumper wires.
- Explain the proper use of a test light.
- Explain the proper use of a logic probe.
- Explain the proper use of analog volt/amp/ohmmeters.
- Explain the proper use of digital volt/amp/ohmmeters.
- Describe when to use the different types of multimeters.
- Explain the proper use of a digital storage oscilloscope.
- Use Ohm's law to determine electrical values in different types of circuits.
- Locate service information.
- Explain the concepts of working as an electrical systems technician.

### INTRODUCTION

This chapter covers some of the typical shop procedures that the electrical systems technician may encounter. This includes proper troubleshooting procedures, the use of special test equipment, the use of service information, and workplace practices.

To be able to properly diagnose electrical components and circuits, you must be able to use many different types of electrical test equipment. In this chapter, you will learn when and how to use the most common types of test equipment. You will also learn which test instrument is best to use to identify the cause of the various types of electrical problems.

Electrical current is a term used to describe the movement or flow of electricity. The greater number of electrons flowing past a given point in a given amount of time, the more current the circuit has. This current, like the flow of water or any other substance, can be measured. The unit for measuring electrical current is the ampere. The instrument used to measure electrical current flow in a circuit is called an **ammeter**.

When any substance flows, it meets resistance. The resistance to electrical flow can be measured. The resistance to current flow produces heat. This heat can be measured to determine the amount of resistance. A unit of measured resistance is called an ohm. Resistance can be measured by an instrument called an **ohmmeter**.

Voltage is electrical pressure. Voltage is the force developed by the attraction of electrons to protons. The more positive one side of the circuit is, the more voltage is present in the circuit. Voltage does not flow; rather it is the pressure that causes current flow.

To have electricity, some force is needed to move the electrons between atoms. This force is the pressure that exists between a positive and negative point within an electrical circuit. This force, also called electromotive force (EMF), is measured in units called volts. One volt

**Classroom  
Manual**

Chapter 2, page 20

is the amount of pressure (force) required to move 1 ampere of current through a resistance of 1 ohm. Voltage is measured by an instrument called a **voltmeter**.

The amount of current that flows in a circuit is determined by the resistance in that circuit. As resistance goes up, the current goes down. The energy used by a load is measured in volts. Amperage stays constant in a circuit, but the voltage is dropped as it powers a load. Measuring voltage drop determines the amount of electrical energy changed to another form of energy by the load.

Also, this chapter covers what it means to work as an electrical systems technician. This includes compensation programs, the importance of workplace and customer relations, communication, and certification.

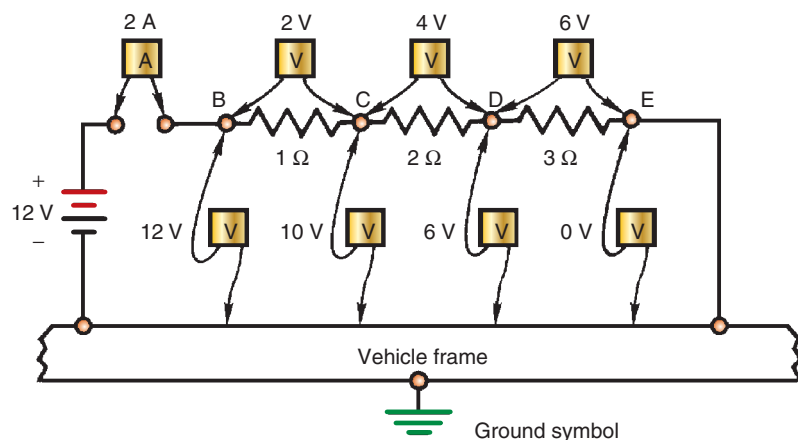
## BASIC ELECTRICAL TROUBLESHOOTING

Troubleshooting electrical problems involves using meters, test lights, and jumper wires to determine if any part of the circuit is open or shorted, or if there is unwanted resistance.

To troubleshoot a problem, always begin by verifying the customer's complaint. Then operate the system and others, to get a complete understanding of the problem. Often there are other problems, which are not as evident or bothersome to the customer, that will provide helpful information for diagnostics. Obtain the correct wiring diagram for the car and study the circuit that is affected. From the diagram, you should be able to identify testing points and probable problem areas. Then test and use logic to identify the cause of the problem.

An ammeter and a voltmeter connected to a circuit at the different locations shown in Figure 2-1 should give readings as indicated when there are no problems in the circuit. An open exists whenever there is not a complete path for current flow. If there is an open anywhere in the circuit, the ammeter will read zero current. If the open is in the 1-ohm resistor, a voltmeter connected from C to ground will read zero. However, if the resistor is open and the voltmeter is connected to points B and C, the reading will be 12 volts. The reason is that the battery, ammeter, voltmeter, 2-ohm resistor, and 3-ohm resistor are all connected together to form a series circuit. Because of the open in the circuit, there is only current flow in the circuit through the meter, not the rest of the circuit. This current flow is very low because the meter has such high resistance. Therefore, the voltmeter will show a reading of 12 volts, indicating no voltage drop across the resistors.

To help you understand this concept, look at what happens if the 2-ohm resistor is open instead of the 1-ohm resistor. A voltmeter connected from point C to ground would indicate 12 volts. The 1-ohm resistor in series to the high resistance of the voltmeter would have little effect on the circuit. If an open should occur between point E and ground, a voltmeter



**FIGURE 2-1** A basic circuit being tested with an ammeter and a voltmeter.

connected from points B, C, D, or E to ground would read 12 volts. A voltmeter connected across any one of the resistors, from B to C, C to D, or D to E, would read zero volts, because there will be no voltage drops if there is no current flow.

A short would be indicated by excessive current and/or abnormal voltage drops. These examples illustrate how a voltmeter and ammeter can be used to check for problems in a circuit. An ohmmeter also can be used to measure the values of each component and compare these measurements to specifications. If there is no continuity across a part, it is open. If there is more resistance than called for, there is high internal resistance. If there is less resistance than specified, the part is shorted.



**WARNING:** Because the human body is a conductor of electricity, observe all safety rules when working with electricity.

## TEST EQUIPMENT

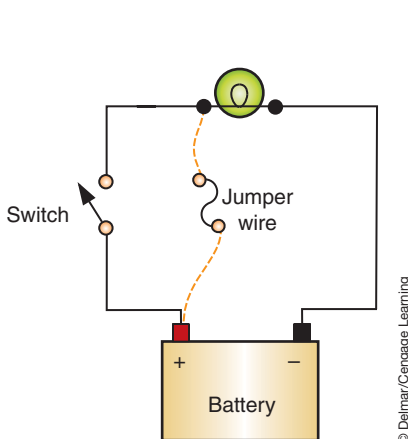
Since electricity is an invisible force, the proper use of test tools will permit the technician to “see” the flow of electrons. Knowing what is being looked at and being able to interpret various meter types will assist in electrical system diagnosis. To diagnosis and repair electrical circuits correctly, a number of common tools and instruments are used. The most common tools are jumper wires, test lights, voltmeters, ammeters, and ohmmeters.

## Jumper Wires

One of the simplest types of test equipment is the **jumper wire**. Connecting one end of the jumper wire to battery positive will provide an excellent 12-volt power supply for testing a component. If the component does not operate when it is in its own circuit, but does operate when battery voltage is jumped to it, the component is good and the fault is within the circuit (Figure 2-2).

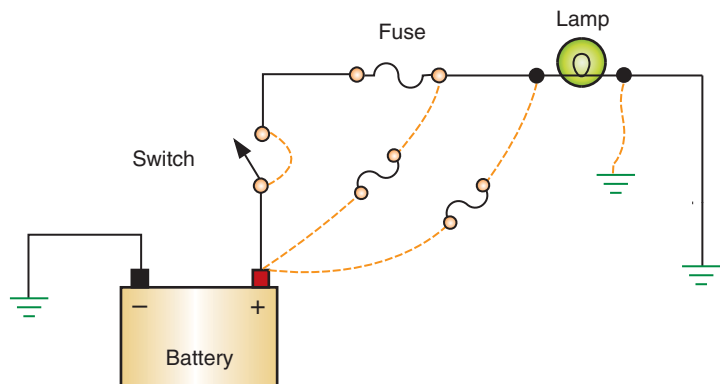
Jumper wires can be used to bypass individual wires, connectors, components, or switches (Figure 2-3). Bypassing a component or wire helps to determine if that part is faulty. If the problem is no longer evident after the jumper wire is installed, the part being bypassed is usually faulty.

To protect the circuit being tested, it is recommended the jumper wire be fitted with an in-line fuse holder or circuit breaker. This will allow the quick changing of fuses to correctly protect the circuit and help prevent damage to the circuit if the jumper wire is connected improperly.



**FIGURE 2-2** Using a fused jumper wire to bypass the switch.

© Delmar/Cengage Learning



**FIGURE 2-3** Examples of locations a jumper wire can be used to bypass a portion of the circuit, and to test the ground circuit. Remember, if you bypass the circuit fuse, the jumper wire should be fitted with a fuse. Never bypass the load component.

© Delmar/Cengage Learning



### CAUTION:

Any broken, frayed, or damaged insulation material requires replacement or repair to the wire. Exposed conductor material from damaged insulation can result in a safety hazard and damage to circuit components.



### CAUTION:

Jumper wires can never be used to jump across the load of the circuit.



### CAUTION:

Always use a fused jumper wire to prevent damage to the electrical circuit or to the vehicle.



### CAUTION:

Do not use a test light to probe for power in an electronic circuit. The increased current draw of the test light may damage the system components.



### CAUTION:

Do not connect a self-powered test light to a circuit that is powered. Doing so will damage the test light.



**WARNING:** Never connect a jumper wire across the terminals of the battery. The battery could explode, causing serious injury.

## Test Lights

There are two types of test lights commonly used in diagnosing electrical problems: non-powered and self-powered. A **test light** is used when the technician needs to “look” for electrical power in the circuit. A typical non-powered test light has a transparent handle that contains a light bulb. A sharp probe extends from one end of the handle while a ground wire with a clamp extends from the other end (Figure 2-4). If the circuit is operating properly, clamping the lead of the test light to ground and probing the circuit at a point of voltage should light the lamp (Figure 2-5).

A test light is limited because it does not display how much voltage is at the point of the circuit being tested. However, by understanding the effects of voltage drop, the technician will be able to interpret the brightness of the test light and relate the results to the expectations of a good circuit. If the lamp is connected after a voltage drop, the lamp will light dimly. Connecting the test lamp before the voltage drop should light the lamp brightly. The light should not illuminate at all if it is probing for voltage after the last resistance.

Another type of circuit tester is the self-powered continuity tester (Figure 2-6). The continuity tester has an internal battery that powers a light bulb. With the power in the circuit turned off or disconnected, the ground clip is connected to the ground terminal of the load component. By probing the feed wire, the light will illuminate if the circuit is complete (has continuity). If there is an open in the circuit, the lamp will not illuminate.



**WARNING:** Never use a self-powered test light to test the air bag system. The battery in the tester can cause the air bag to deploy.

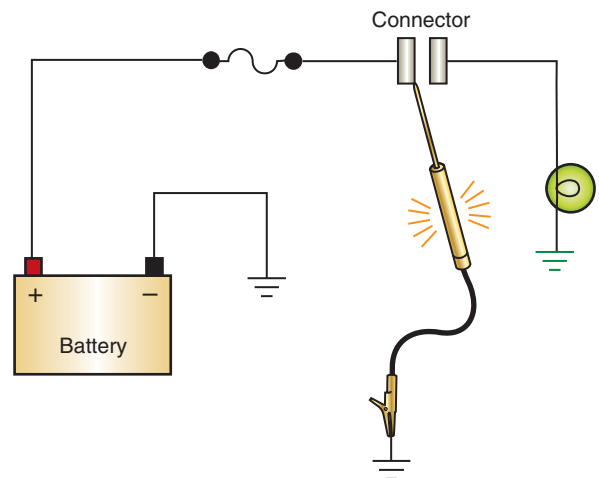
## Logic Probes

Many computer-controlled systems use a pulsed voltage to transmit messages or to operate a component. A standard or self-powered test light should not be used to test these circuits since they may damage the computer. However, a **logic probe** (Figure 2-7) can be used.



© Delmar/Cengage Learning

**FIGURE 2-4** A typical test light used to probe for voltage in a circuit.



© Delmar/Cengage Learning

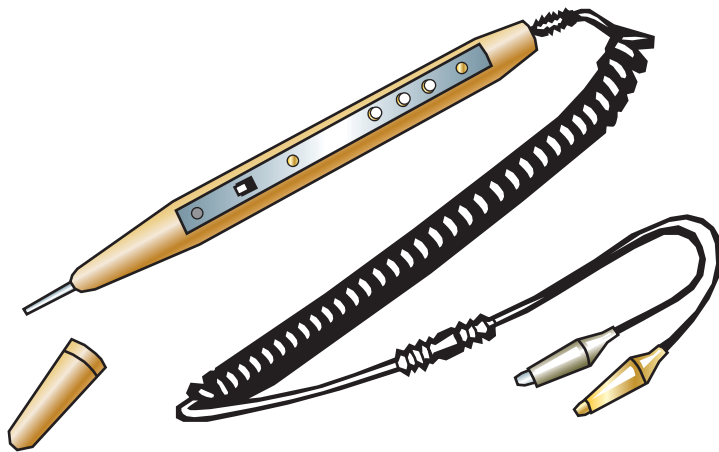
**FIGURE 2-5** If voltage is present, the test light will illuminate.





© Delmar/Cengage Learning

**FIGURE 2-6** Typical self-powered continuity tester.



© Delmar/Cengage Learning

**FIGURE 2-7** A typical logic probe.

A logic probe looks something like a test light except it contains three different-colored LEDs. The red LED will light if there is high voltage at the point in the circuit being tested. The green LED will light to indicate the presence of low voltage. The yellow LED lights to indicate the presence of voltage pulses. If the voltage is a pulsed voltage from a high level to a low level, the yellow LED will be on and the red and green LEDs will cycle, indicating the change in voltage.

## MULTIMETERS

The **multimeter** is one of the most versatile tools used to diagnose electrical systems. It can be used to measure voltage, resistance, and amperage. In addition, some types of multimeters are designed to test diodes and measure frequency, duty cycle, temperature, and rotation speed. Multimeters are available in analog (swing needle) and digital display.

### Analog Meters

Analog meters use a sweeping needle and a scale to display test values (Figure 2-8). All analog meters use a **D'Arsonval movement** (Figure 2-9). A D'Arsonval movement is a small coil of wire mounted in the center of a permanent horseshoe-type magnet. A pointer or needle is mounted to the coil. When taking a measurement, current flows through the coil and creates a magnetic field around the coil. The coil rotates within the permanent magnet as its magnetic field interacts with the magnetic field of the permanent magnet. The amount of rotation is determined by the strength of the magnetic field around the coil. Since the needle moves with the coil, it reflects the amount of coil movement and its direction.



### SPECIAL TOOLS

- Analog volt or ohm meter
- DMM
- Backprobing tools



### CAUTION:

Do not use an analog meter on a computer-controller circuit unless expressly directed to do so in the service information. Damage to the circuit or computer may result.



FIGURE 2-8 An analog meter.

© Delmar/Cengage Learning

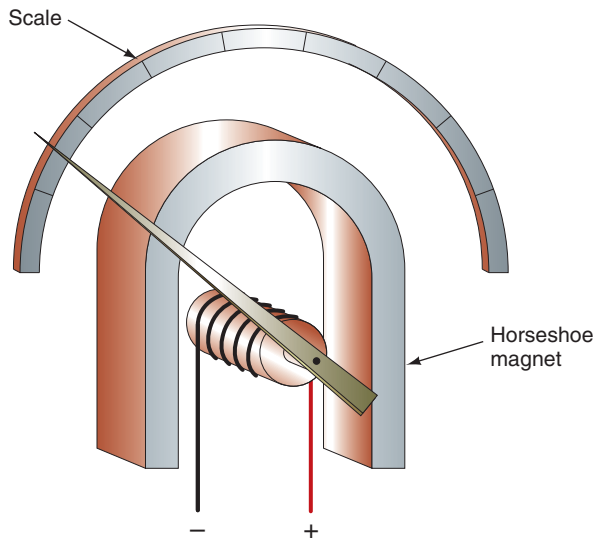


FIGURE 2-9 D'Arsonval movement is the basis for the movement of an analog meter.

© Delmar/Cengage Learning

**Digital multimeters (DMM)** are also referred to as DVOMs (digital volt/ohmmeters).



### CAUTION:

Not all DMMs are rated at 10 megohms of impedance. Be sure of the meter you are using to prevent electronic component damage.

## Digital Meters

With modern vehicles incorporating computer-controlled systems, the need for **digital multimeters (DMM)** is required (Figure 2-10). Digital multimeters (also called DVOMs) display values using liquid crystal displays instead of a swinging needle. They are basically a computer that determines the measured value and displays it for the technician. Computer systems have integrated circuits that operate on very low amounts of current. Analog meters can overload computer circuits and burn out the IC chips since they allow a large amount of current to flow through the circuit. On the other hand, most digital multimeters have very high input resistance (impedance) which prevents the meter from drawing current when connected to a circuit. Most DMMs have at least 10 megohms (10 million ohms) impedance. This reduces the risk of damaging computer circuits and components.

Digital meters rely on electronic circuitry to measure electrical values. The measurements are displayed with LEDs or on a liquid crystal display (LCD). Digital meters tend to give more accurate readings and are certainly much easier to read. Rather than reading a scale at the point where the needle lines up, digital meters simply display the measurement in a numerical value. This also eliminates the almost certain error caused by viewing an analog meter at an angle.



© Delmar/Cengage Learning

FIGURE 2-10 Digital multimeter.

## Voltmeters

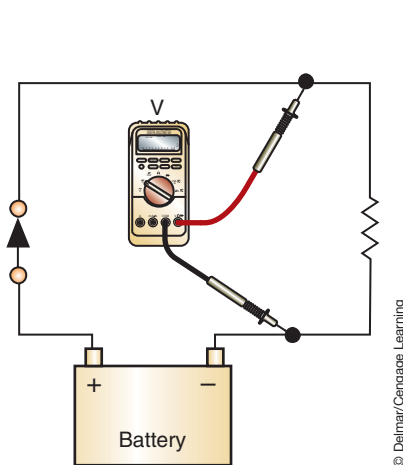
A voltmeter can be used to measure the voltage available at the battery. It can also be used to test the voltage available at the terminals of any component or connector. In addition, a voltmeter tests voltage drop across an electrical circuit, component, switch, or connector.

A voltmeter has two leads: a red positive lead and a black negative lead. The red lead should be connected to the positive side of the circuit or component. The black lead should be connected to ground or to the negative side of the component. A voltmeter is connected in parallel with a circuit (Figure 2-11).

Figure 2-12 shows how to check for voltage in a closed circuit. The voltage at point A is 12 volts positive. There is a drop of 6 volts over the 1-ohm resistor and the reading is 6 volts positive at point B. The remaining voltage drops in the motor load and the voltmeter reads 0 at point C, indicating normal motor circuit operation.

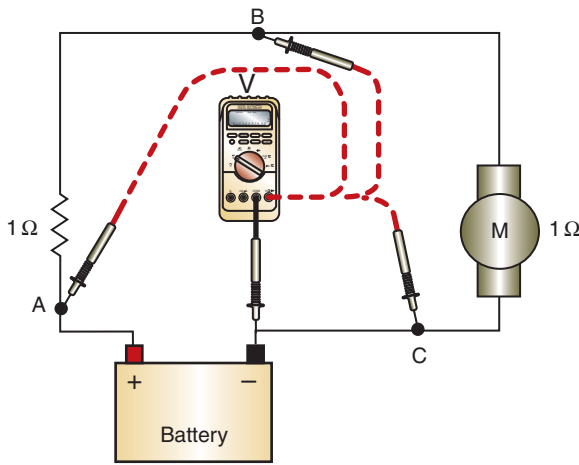
When reading voltage in the same circuit that has an open (Figure 2-13A), 12 volts will be indicated at any point ahead of the open. This is indicated at points A, B, and C, but not through X. Since the circuit is open, and there is no electrical flow, there is no voltage drop across a resistor or load.

The loss of voltage due to resistance in wires, connectors, and loads is called **voltage drop**. Voltage drop is the amount of electrical energy converted to another form of energy.



© Delmar/Cengage Learning

FIGURE 2-11 Connecting a voltmeter in parallel to the circuit.



© Delmar/Cengage Learning

FIGURE 2-12 Checking voltage in a closed circuit.

### Classroom Manual

Chapter 2, page 20



### SPECIAL TOOLS

DMM



### SERVICE TIP:

Using a voltmeter to measure voltage drop is one of the easiest ways of testing a circuit's ability to carry current under load.

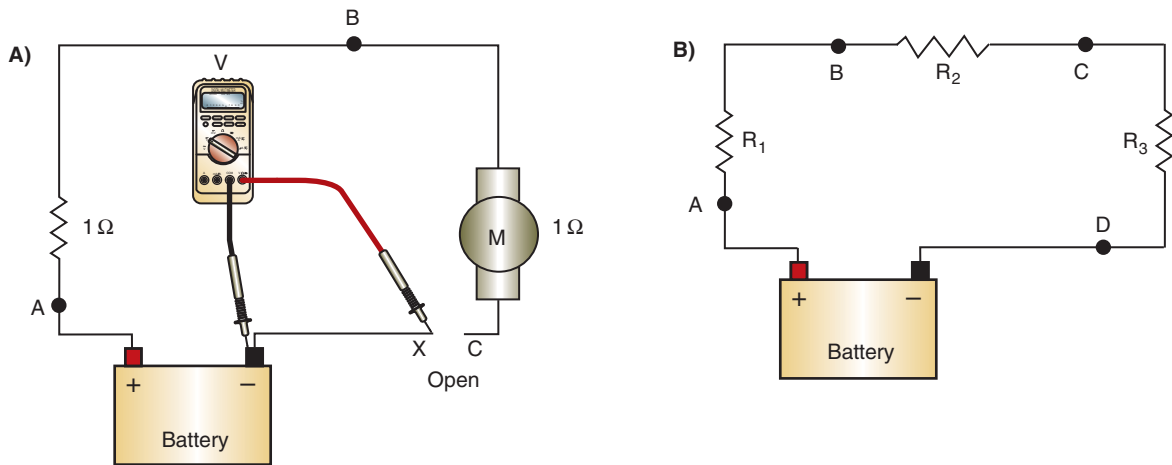


FIGURE 2-13 Using a voltmeter to (A) find an open circuit and (B) to check voltage drop.

© Delmar/Cengage Learning

### Classroom Manual

Chapter 2, page 23



### SERVICE TIP:

A “T” pin that is used for sewing pant and suit hems can be used as a backprobing tool.

For example, to make a lamp light, electrical energy is converted to heat energy. It is the heat that makes the lamp light.

To measure voltage drop across each load, it must be determined what point is the most positive and what point is the most negative in the circuit. A point in the circuit can be either positive or negative, depending on what is being measured. Referring to Figure 2-13B, if voltage drop across  $R_1$  is being measured, the positive meter lead is placed at point A and the negative lead at point B. The voltmeter will measure the difference in volts between these points. However, to measure the voltage drop across  $R_2$ , the polarity of point B is positive and point C is negative. The reason being that point B is the most negative for  $R_1$ , yet it is the most positive point for  $R_2$ . To measure voltage drop across  $R_3$ , point C is positive and point D is negative. The positive lead of the voltmeter should be placed as close as possible to the positive side of the battery in the circuit. The procedure for measuring a voltage drop is shown in Photo Sequence 3.

Often, voltage drop testing requires the technician to **backprobe** a connector to access the terminal. Backprobing requires the use of a backprobing tool (Figure 2-14) that will slide into the back side of a connector. The tool should be inserted between the wire’s insulation and the connector’s seal until it contacts the terminal (Figure 2-15). When performed properly the wire, connector, or terminal will not be damaged. It is important to use as small a backprobing tool as possible.

All wiring must have resistance values low enough to allow enough voltage to the load for proper operation. The maximum allowable voltage loss due to voltage drops across wires, connectors, and other conductors in an automotive circuit is 10% of the system voltage. Therefore, in a 12-volt automotive electrical system, this maximum total loss is 1.2 volts.

Figure 2-16 shows two headlights connected to a 12-volt battery by two wires. Each wire has a resistance of only 0.05 ohms. Each headlight has a resistance of 2 ohms. The two headlights are wired in parallel and have a total resistance of 1 ohm. If the wires had no resistance, the total resistance of the circuit would be 1 ohm and the current flowing through the circuit would be 12 amps. However, the wires have resistance and the total resistance of the circuit is 1.1 ohms (1 ohm + 0.05 ohms + 0.05 ohms). Therefore the circuit current is 10.9 amps ( $I = E/R$ ,  $I = 12 \text{ V}/1.1 \text{ ohms}$ ). The voltage drop across the bulbs would be 12 volts if there was no resistance in the wires. Now the voltage drop across the bulbs is only 10.9 volts ( $E = I \times R$ ,  $E = 10.9 \text{ amps} \times 1 \text{ ohm}$ ). Although it may not be very noticeable, the light bulbs will not be as bright as they should be because of the decreased current and the decreased voltage drop.

A voltmeter can also be used to check for proper circuit grounding. If the voltmeter reading indicates full voltage at the lights, but the bulbs are not illuminated, the bulbs or sockets

## PERFORMING A VOLTAGE DROP TEST

All photos in this sequence are © Delmar/Cengage Learning.



**P3-1** The tools required to perform this task include voltmeter, backprobing tool, and fender covers.



**P3-2** Set the voltmeter to its lowest DC voltage scale.



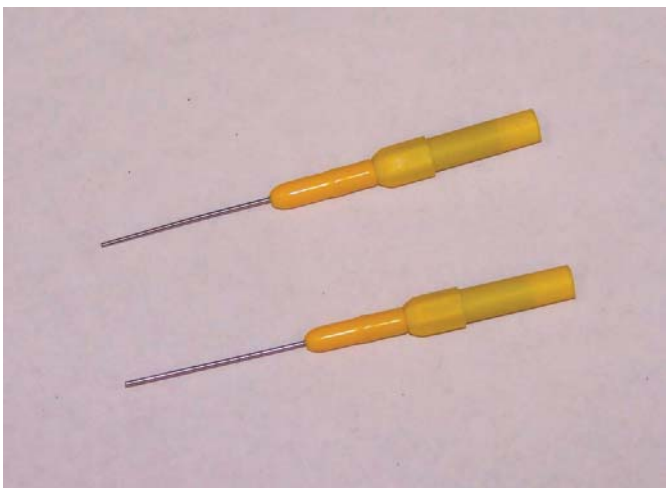
**P3-3** To test the voltage drop of the whole insulated side of the circuit, connect the red (positive) voltmeter test lead to the battery positive (+) terminal.



**P3-4** Use the backprobing tool to connect the black (negative) voltmeter test lead into the low beam terminal of the headlight socket. Make sure that you are connected to the input side of the headlight.



**P3-5** Turn on the headlights (low beam) and observe the voltmeter readings. The voltmeter will indicate the amount of voltage that is dropped between the battery and the headlight.



**FIGURE 2-14** Backprobing tools.

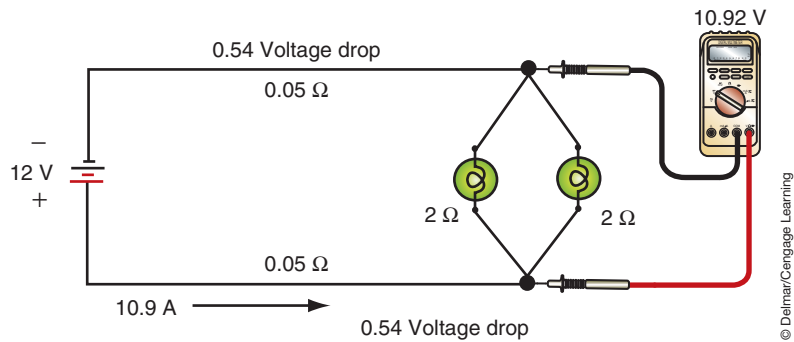


**FIGURE 2-15** Backprobing tool properly inserted into the back of a connector.

© Delmar/Cengage Learning

© Delmar/Cengage Learning





**FIGURE 2-16** Measuring the voltage drop across a lamp. Notice the wires offer some resistance.

© Delmar/Cengage Learning

**Root mean square (RMS)** meters convert the AC signal to a comparable DC voltage signal.

**Average responding** meters display the average voltage peak.

A **sine wave** is a waveform that shows voltage changing polarity from positive to negative.

**Classroom Manual**

Chapter 2, page 23



**SPECIAL TOOLS**

DMM

could be bad or the ground connection is faulty. An easy way to check for a defective bulb is to replace it with a known good bulb.

If the bulbs are good, the problem lies in either the light sockets or ground wires. Connect the voltmeter to the ground wire and a good ground. If the light socket is defective, the voltmeter will read 0 volts. If the socket is not defective, but the ground wire is broken or disconnected, the voltmeter will read very close to battery voltage. In fact, any voltage reading would indicate a bad or poor ground circuit. The higher the voltage, the greater the problem.

Thus far, we have discussed using a voltmeter on a direct current (DC) circuit. The voltmeter can also measure alternating current (AC). There are two methods used to display AC voltage: **root mean square (RMS)** and **average responding**. If the AC voltage signal is a true **sine wave**, both methods would display the same value. However, most automotive sensors do not produce a pure sine wave signal. The technician must know how the different meters will display the AC voltage reading under these circumstances. The type of display the voltmeter uses can be found in the meter's operating manual.

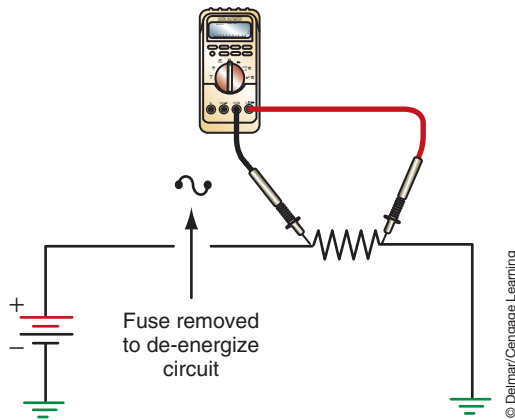
## Ohmmeters

In contrast to the voltmeter, which uses the voltage available in the circuit, an ohmmeter is battery powered. The circuit being tested must be open. If the power is on in the circuit, the ohmmeter may be damaged. Most analog ohmmeters use a multiplier to determine higher resistance readings. A multiposition switch is used to select these multipliers or ranges. Normal ranges are labeled  $R \times 1$ ,  $R \times 10$ ,  $R \times 100$ , and  $R \times 1K$ . The reading on the ohmmeter must be multiplied by the value indicated by the range. If the reading is 22 ohms and the selected range is  $R \times 1$ , the resistance value is 22 ohms. However, if the meter reads 22 ohms and the selected range is  $R \times 100$ , the resistance value is 2,200 ( $22 \times 100$ ) ohms. The ranges are selected according to the component being tested. If the resistance of the component is unknown, start measuring with the lowest range and move up through the ranges until a good reading can be made. This will prevent misinterpreting infinity readings.

The two leads of the ohmmeter are placed across or in parallel with the circuit or component being tested. The red lead is placed on the positive side of the circuit and the black lead is placed on the negative side of the circuit (Figure 2-17). The meter sends current through the component and determines the amount of resistance based on the voltage dropped across the load. The scale of an ohmmeter reads from 0 to infinity ( $\infty$ ). A 0 reading means there is no resistance in the circuit and may indicate a short in a component that should show a specific resistance. For example, a coil winding should have a high resistance value, a 0-ohm reading would indicate the coil windings are being bypassed. An infinity reading indicates a number higher than the meter can measure. This usually is an indication of an open circuit.

The test chart, shown in Table 2-1, illustrates the readings that may be expected from an ohmmeter or voltmeter under different conditions. It is important to become familiar with these examples in order to analyze circuits.





**FIGURE 2-17** Measuring resistance with an ohmmeter. The meter is connected in parallel with the component being tested after power is removed to the circuit.

**TABLE 2-1** CIRCUIT TEST CHART

Type of Defect	Test Unit	Expected Results
Open	Ohmmeter	$\infty$ infinite resistance between conductor ends
	Test light	No light after open
	Voltmeter	$\emptyset$ volts at end of conductor after the open
Short to Ground	Ohmmeter	$\emptyset$ resistance to ground
	Test light	Lights if connected across fuse
	Voltmeter	Generally not used to test for ground
Short	Ohmmeter	Lower than specified resistance through load component $\emptyset$ resistance to adjacent conductor
	Test light	Light will illuminate on both conductors
	Voltmeter	A voltage will be read on both conductors
Excessive Resistance	Ohmmeter	Higher than specified resistance through circuit
	Test light	Light illuminates dimly
	Voltmeter	Voltage will be read when connected in parallel over resistance



**CAUTION:**

Since the ohmmeter is self-powered, never use an ohmmeter on a powered circuit.

Ohmmeters are also used to trace and check wires or cables. Assume that one wire of a four-wire cable is to be found. Connect one probe of the ohmmeter to the known wire at one end of the cable and touch the other probe to each wire at the other end of the cable. Any evidence of resistance, such as meter needle deflection, indicates the correct wire. Using this same method, you can check a suspected defective wire. If low resistance is shown on the meter, the wire is sound. If infinite resistance is measured, the wire is defective (open). If the wire is okay, continue checking by connecting the probe to other leads. Any indication of resistance indicates that the wire is shorted to one of the other wires and that the harness is defective.

**Ammeters**

An ammeter measures current flow in a circuit. Circuit problems can also be identified by using an ammeter. An ammeter must be placed into series with the circuit being tested (Figure 2-18). Normally, this requires disconnecting a wire or connector from a component and connecting the ammeter between the wire or connector and the component. The red

**Classroom Manual**

Chapter 2, page 21



**SPECIAL TOOLS**

DMM



### CAUTION:

Never place the leads of an ammeter across the battery or a load. This puts the meter in parallel with the circuit and will blow the fuse in the ammeter or possibly destroy the meter.



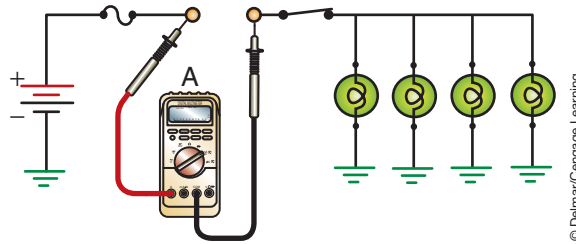
### CAUTION:

When testing for a short, always use a fused jumper wire. Never bypass the fuse with a wire. The fuse should be rated at no more than 50% higher capacity than specifications. This offers circuit protection and provides enough amperage for testing. After the problem is found and corrected, be sure to install the specified rating of fuse for circuit protection.



### SERVICE TIP:

Most handheld DMMs have the option for an inductive pick-up that will measure amperage between 10 and 20 amps (depending on model). This makes measuring amperage on some circuits easier since it eliminates the need to connect the test leads in series.



**FIGURE 2-18** Measuring current flow with an ammeter. The meter must be connected in series with the circuit.

© Delmar/Cengage Learning

lead of the ammeter should always be connected to the most positive side of the connector and the black lead should be connected to the least positive side.

Most hand-held multimeters have a 10-ampere protection device. This is the highest amount of current flow the meter can read. When using the ammeter, start on a high scale and work down to obtain the most accurate readings.

It is much easier to test current using an ammeter with an inductive pickup (Figure 2-19). The pickup clamps around the wire or cable being tested. The inductive clamp has an arrow on it to indicate proper attachment to the conductor. The arrow indicates current flow direction using the conventional flow theory of positive to negative. These ammeters measure amperage based on the magnetic field created by the current flowing through the wire. This type of pickup eliminates the need to separate the circuit to insert the meter leads.

Because ammeters are built with very low internal resistance, connecting them in series does not add any appreciable resistance to the circuit. Therefore, an accurate measurement of the current flow can be taken.

For example, assume that a circuit normally draws 5 amps and is protected by a 6-amp fuse. If the circuit constantly blows the 6-ampere fuse, a short exists somewhere in the circuit. Mathematically, each light should draw 1.25 amperes ( $5 \div 4 = 1.25$ ). To find the short, disconnect all lights by removing them from their sockets. Then, close the switch and read the ammeter. With the load disconnected, the meter should read 0 amperes. If there is any reading, the wire between the fuse block and the socket is shorted to ground.

If zero amps was measured, reconnect each light in sequence; the reading should increase 1.25 amperes with each bulb. If, when making any connection, the reading is higher than expected, the problem is in that part of the light circuit.



**FIGURE 2-19** An ammeter with an inductive pickup. The inductive pickup eliminates the need to connect the meter in series with the circuit.

© Delmar/Cengage Learning

## Additional DVOM Functions

Some multimeters feature additional functions besides measuring AC or DC voltage, amperage, and ohms. Many multimeters are capable of measuring engine revolutions per minute (rpm), ignition dwell, diode condition, distributor condition, frequency, and temperature.

Some meters have a MIN/MAX function that displays the minimum, maximum, and average values received by the meter during the time the test was being recorded. This feature is valuable when checking sensors, output commands, or circuits for electrical **noise**. Noise is an unwanted voltage signal that rides on a signal. Noise is usually the result of radio frequency interference (RFI) or electromagnetic induction (EMI). The noise causes slight increases and decreases in the voltage signal to, or from, the computer. Another definition of noise is an AC signal riding on a DC voltage. The computer may attempt to react to the small changes in the signal as a result of the noise. This means the computer is responding to the noise and not the voltage signal, resulting in incorrect component operation.

Also, some multimeters may have the capabilities to measure **duty cycle**, pulse width, and frequency. Duty cycle is the measurement of the amount of “on” time as compared to the time of a **cycle** (Figure 2-20). A cycle is one set of changes in a signal that repeats itself several times. The duty cycle is displayed in a percentage. For example, a 60% duty cycle means the device is on 60% of the time and off 40% of the time of one cycle.

**Pulse width** is similar to duty cycle except that it is a measurement of time the device is turned on within a cycle (Figure 2-21). Pulse width is usually measured in milliseconds.

As previously mentioned, some multimeters can measure **frequency** (Figure 2-22). Frequency is a measure of the number of cycles that occur in one second. The higher the frequency, the more cycles that occur in a second. Frequency is measured in **hertz**. If the cycle occurs once per second, the frequency is one hertz. If the cycle is 300 times per second, the frequency is 300 hertz.

To accurately measure duty cycle, pulse width, and frequency, the meter’s trigger level must be set. The trigger level tells the meter when to start counting. Trigger levels can be set

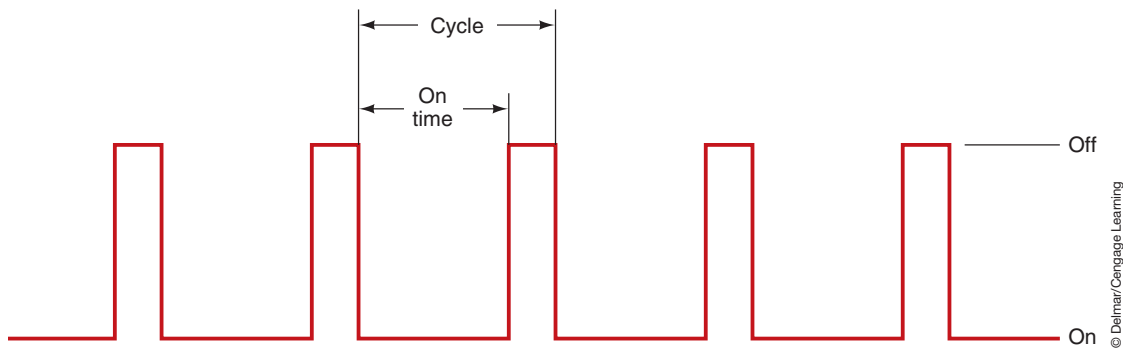


FIGURE 2-20 Duty cycle.

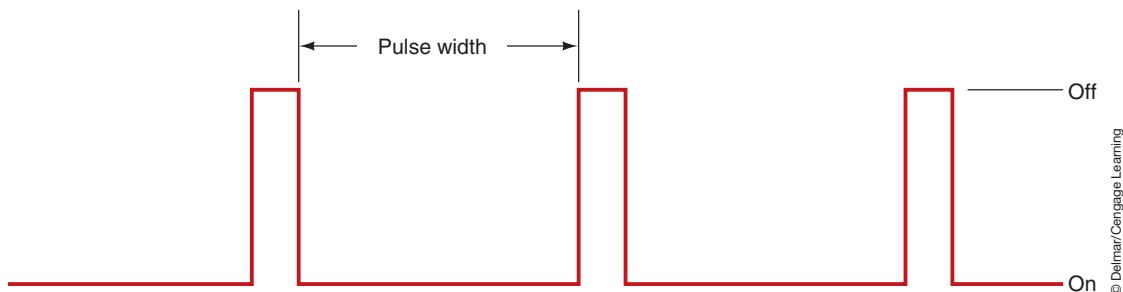
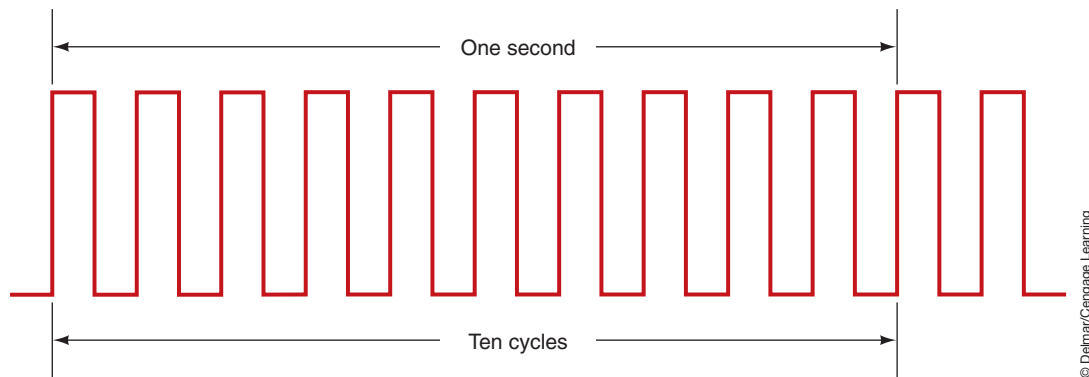


FIGURE 2-21 Pulse width.



**FIGURE 2-22** Frequency signal.

© Delmar/Cengage Learning

at certain voltage levels or at a rise or fall in the voltage. Normally, meters have a built-in trigger level that corresponds with the voltage setting. If the voltage does not reach the trigger level, the meter will not begin to recognize a cycle. On some meters, you can select between a rise or fall in voltage to trigger the cycle count. A rise in voltage is a positive increase in voltage. This setting is used to monitor the activity of devices whose power feed is controlled by a computer. A fall in voltage is negative voltage. This setting is used to monitor ground-controlled devices.

## Reading the DVOM

With the increased use of the digital volt/ohmmeter (DVOM), it is important for the technician to be able to accurately read the meter. By becoming proficient in the use of the DVOM, technicians will have confidence in their conclusions and recommended repairs. This will eliminate the replacement of parts that were not faulty. There are deviations between the different DVOM manufacturers as to the way the display is presented, but most follow the method described here.

Multimeters either have an “auto range” feature, in which the appropriate scale is automatically selected by the meter, or they must be manually set to a particular scale. Either way, to designate particular ranges and readings, meters display a prefix before the reading or range. Meters use the prefix because they cannot display long numbers. Values such as 20,200  $\Omega$  cannot be displayed as a whole number. As a result, scales are expressed as a multiple of tens or use the prefix K, M, m, and  $\mu$  (Table 2-2). The prefix K stands for kilo and represents 1,000 units. For example, a reading of 10K equals 10,000. An M stands for mega and represents 1,000,000 units. A reading of 10M would represent 10,000,000. An m stands for milli and represents 0.001 of a unit. A reading of 10m would be 0.010. The symbol  $\mu$  stands for micro and represents 0.000001 of a unit. In this case a reading of 125.0 $\mu$  would represent 0.000125.

If the display has no prefix before the unit being measured (V, A,  $\Omega$ ), the reading displayed is read directly. For example, if the reading was 1.243 V, the actual voltage value is

**TABLE 2-2** COMMON PREFIXES USED ON DIGITAL MULTIMETERS.

PREFIX	SYMBOL	RELATION TO BASIC UNIT
Mega	M	1,000,000
Kilo	K	1,000
Milli	m	0.001 or $\frac{1}{1000}$
Micro	$\mu$	0.000001 or $\frac{1}{1,000,000}$
Nano	n	0.000000001
Pico	p	0.000000000001

1.243. However, if there is a prefix displayed, then the decimal point will need to be floated to determine actual readings. If the prefix is M (mega), then the decimal is floated six places to the right. For example, a reading display of 2.50 MΩ is actually 2,500,000 ohms. A reading display of 0.250 MΩ is actually 250,000 ohms.

A prefix of K (kilo) means the decimal point needs to move three places to the right. For example, a display reading of 56.4 KΩ is actually 56,400 ohms. A reading of 1.264 KΩ is actually 1,264 ohms.

If the prefix is m (milli), the decimal is floated three places to the left. For example, a reading of 25.4 mA is representing 0.0254 amperes. A display of 165.0 mA is actually 0.165 amperes.

Finally, if the prefix is a μ (micro), the decimal is floated six points to the left. A reading displayed as 125.3μ would represent 0.0001253 amperes while a reading of 4.6 μA is actually 0.0000046 amperes.

When using the ohmmeter function of the DVOM, make sure power to the circuit being tested is turned off. Also, be sure to calibrate the meter before taking measurements. This is done by holding the two test leads together. Most DVOMs will self-calibrate while others will need to be adjusted by turning a knob until the meter reads zero. Connect the DVOM in parallel to the portion of the circuit being tested. If continuity is good, the DVOM will read zero or close to zero even on the lowest scale. If the continuity is very poor, the DVOM will display an infinite reading. This reading is usually shown as a “1.000,” a “1,” or an “OL.”

## Insulation Tester

An insulation tester can be a stand-alone meter or an additional function of a DMM (Figure 2-23). It is used to measure the insulation resistance on the powered down HV system when servicing a HEV. Isolation tests are only performed on systems that have the power removed.

To test for insulation leakage of the high-voltage system, begin by inserting the insulation test probe into the + terminal and the ground lead into the – terminal. Do not connect the leads to the volt-ohm terminals. Turn the knob to the “INSULATION” position. In this position, a battery level check is performed. Confirm that the battery level test has passed. Press the “RANGE” button to select the desired voltage range. If performing an isolation test on an HEV, this should be set to 500 volts. Next, connect the leads to the circuit you are testing. The meter will automatically detect if the circuit is powered. The meter display should indicate



© Delmar/Cengage Learning

**FIGURE 2-23** An insulation meter is used on many HEVs to determine insulation leaks in the high-voltage system.



a series of dashed lines. If the meter displays >30 V, then there is voltage greater than 30 volts in the circuit and the test meter will not perform the insulation test. Push and hold the “TEST” button on the red insulation test lead. While the test is in progress, the applied voltage will be displayed in the lower right corner on the screen and the resistance in M ohms or G ohms will be displayed in the center of the screen. Leave the test leads attached to the circuit and release the “TEST” button. The meter will continue to display the resistance reading while the circuit is discharged through the meter.

## LAB SCOPES AND OSCILLOSCOPES

Oscilloscopes are commonly called scopes.



### SPECIAL TOOLS

Lab scope

The squares formed by the grid are called major divisions. These are further defined by smaller divisions called minor divisions.

An oscilloscope is a visual voltmeter (Figure 2-24). For many years, technicians have used scopes to diagnose ignition, fuel injection, and charging systems. These scopes, called “tune-up scopes,” were normally part of a large diagnostic machine, although some were stand-alone units. In recent years, an electronic scope, referred to as a lab scope, has become the diagnostic tool of choice for many good technicians.

The oscilloscope is very useful in diagnosing many electrical problems quickly and accurately. Digital and analog voltmeters do not react fast enough to read systems that cycle quickly. The oscilloscope may be considered as a very-fast-reacting voltmeter that reads and displays voltages. The scope allows the technician to view voltage over time (Figure 2-25). These voltage readings appear as a voltage trace on the oscilloscope screen.

An upward movement of the voltage trace on an oscilloscope screen indicates an increase in voltage, and a downward movement of this trace represents a decrease in voltage. As the voltage trace moves across an oscilloscope screen, it represents a specific length of time. Most oscilloscopes of this type are referred to as analog scopes or real-time scopes. This means the voltage activity is displayed without any delay.

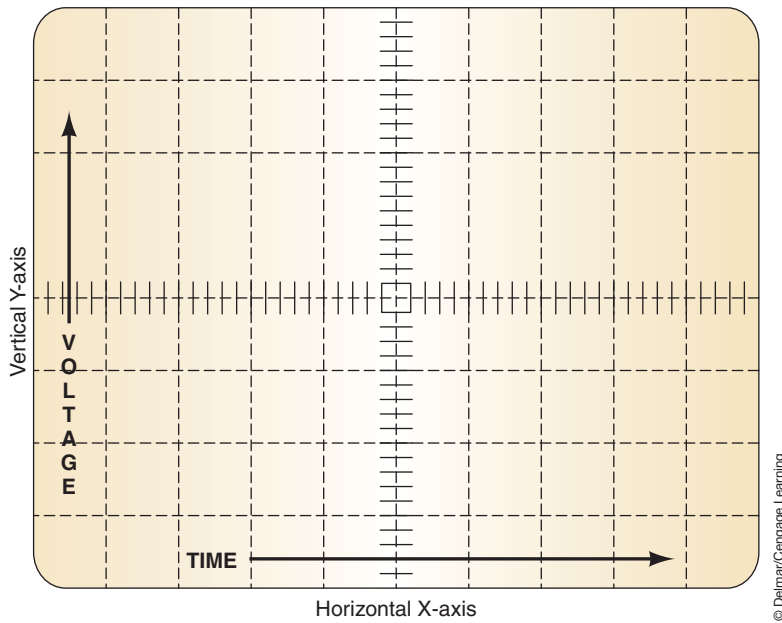
Today, most technicians use a variation of the oscilloscope called a lab scope. These divisions set up a grid pattern on the screen. Time is represented by the horizontal movement of the waveform. Voltage is measured with the vertical position of the waveform. Since the scope displays voltage over time, the waveform moves from left (the beginning of measured time) to the right (the end of measured time). The value of the divisions can be adjusted to improve the view of the voltage waveform. For example, the vertical scale can be adjusted so that each division represents 0.5 volts, and the horizontal scale can be adjusted so that each division



© Delmar/Cengage Learning

FIGURE 2-24 Oscilloscope.





**FIGURE 2-25** Grids on a scope screen serve as a time and voltage reference.

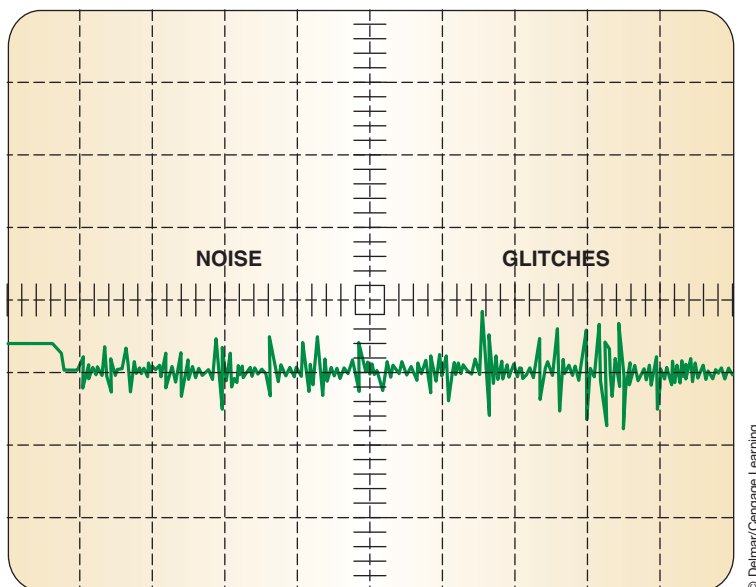
© Delmar/Cengage Learning

equals 0.005 (5 milliseconds). This allows the technician to view small changes in voltage that occur in a very short period of time. The grid serves as a reference for measurements.

Since a scope displays actual voltage, it will display any electrical noise or disturbances that accompany the voltage signal (Figure 2-26). This noise can cause intermittent problems with unpredictable results. When a computer receives a voltage signal with noise, it will try to react to the minute changes. As a result, the computer responds to the noise rather than the voltage signal.

Electrical disturbances or **glitches** are momentary changes in the signal. These can be caused by intermittent shorts to ground, shorts to power, or opens in the circuit. These problems can occur for only a moment or may last for some time. A lab scope is handy for finding these and other causes of intermittent problems. By observing a voltage signal and wiggling

The waveform on a scope is commonly called a trace.



**FIGURE 2-26** RFI noise and glitches showing as voltage signals.

© Delmar/Cengage Learning

or pulling a wiring harness, any looseness can be detected by a change in the voltage signal. This type of testing is commonly referred to as a “wobble test.”

The digital scope, commonly called a digital storage oscilloscope or DSO, converts the voltage signal into digital information and stores it into its memory. Some DSOs send the signal directly to a computer or a printer, or save it to a disk. To help with diagnosis, a technician can “freeze” the **captured signal** for closer analysis. DSOs also have the ability to capture low-frequency signals. Low-frequency signals tend to flicker when displayed on an analog screen. To have a clean waveform on an analog scope, the signal must be repetitive and occurring in real time. The signal on a DSO is not quite real time. Rather, it displays the signal as it occurred a short time before.

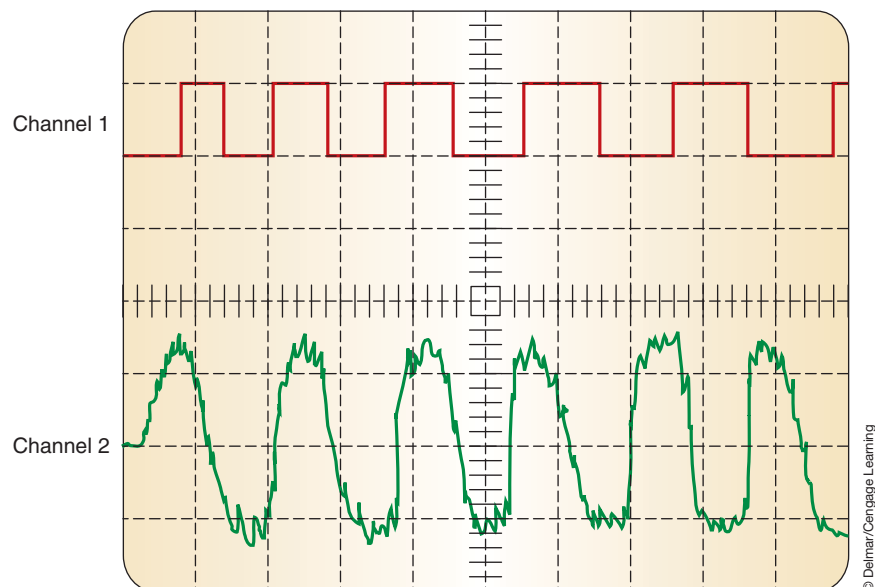
This delay is actually very slight. Most DSOs have a sampling rate of one million samples per second. This is quick enough to serve as an excellent diagnostic tool. This fast sampling rate allows slight changes in voltage to be observed. Slight and quick voltage changes cannot be observed on an analog scope.

Both an analog and a digital scope can be dual-trace scopes (Figure 2-27). This means they both have the capability of displaying two traces at one time. By watching two traces simultaneously, you can watch the cause and effect of a sensor, as well as compare a good or normal waveform to the one being displayed.

## Waveforms

A waveform represents voltage over time. Any change in the amplitude of the trace indicates a change in the voltage. When the trace is a straight horizontal line, the voltage is constant (Figure 2-28). A diagonal line up or down represents a gradual increase or decrease in voltage. A sudden rise or fall in the trace indicates a sudden change in voltage.

Scopes can display AC and DC, one at a time or both, as in the case of noise caused by RFI. The consistent change of polarity and amplitude of the AC signal causes slight changes in the DC voltage signal. A normal AC signal changes its polarity and amplitude over a period of time. The waveform created by AC voltage is typically a sine wave (Figure 2-29). One complete sine wave shows the voltage moving from zero to its positive peak, moving down through zero to its negative peak, and returning to zero. If the rise and fall from positive and negative is the same, the wave is said to be **sinusoidal**. If the rise and fall are not the same, the wave is nonsinusoidal.



**FIGURE 2-27** A dual-trace scope can show two patterns at the same time.

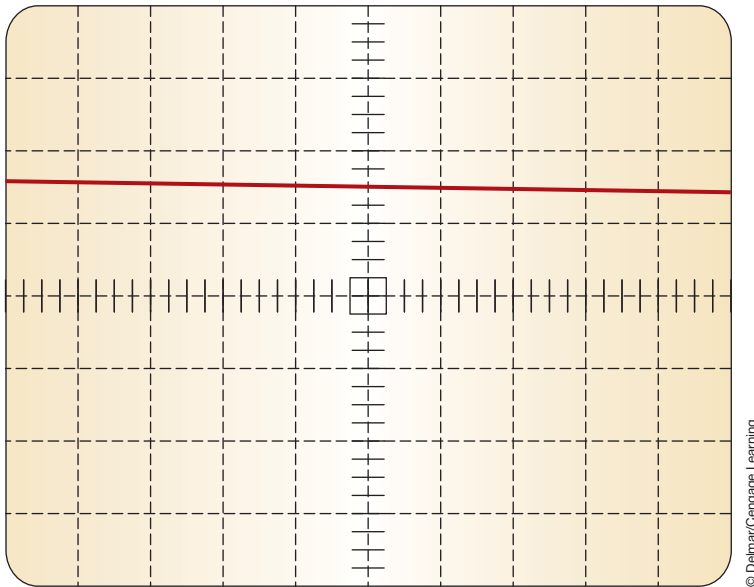


FIGURE 2-28 A waveform showing a constant voltage.

© Delmar/Cengage Learning

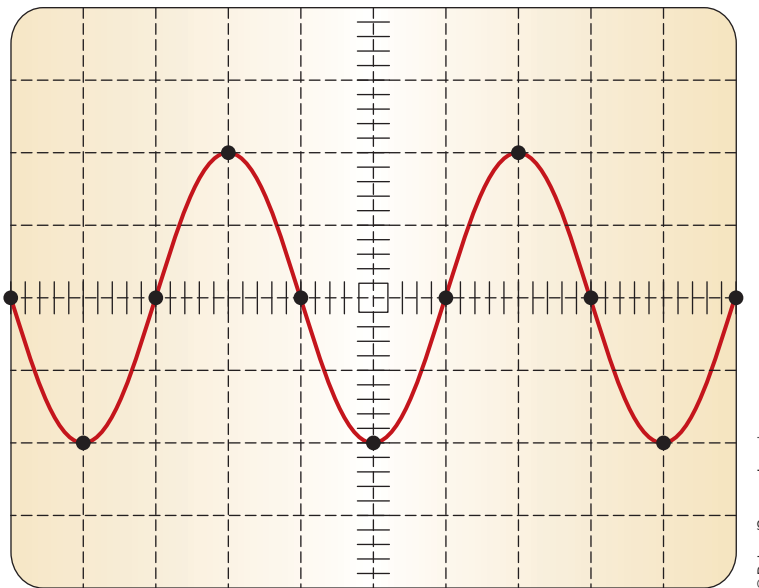
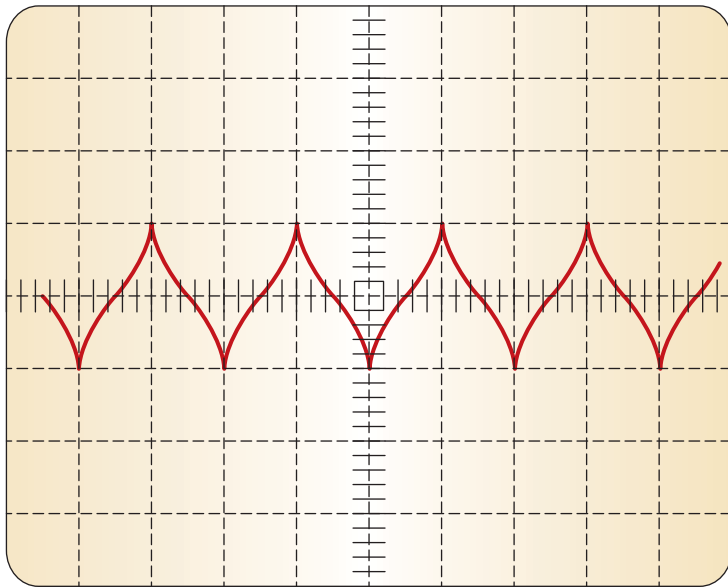


FIGURE 2-29 An AC voltage sine wave.

© Delmar/Cengage Learning

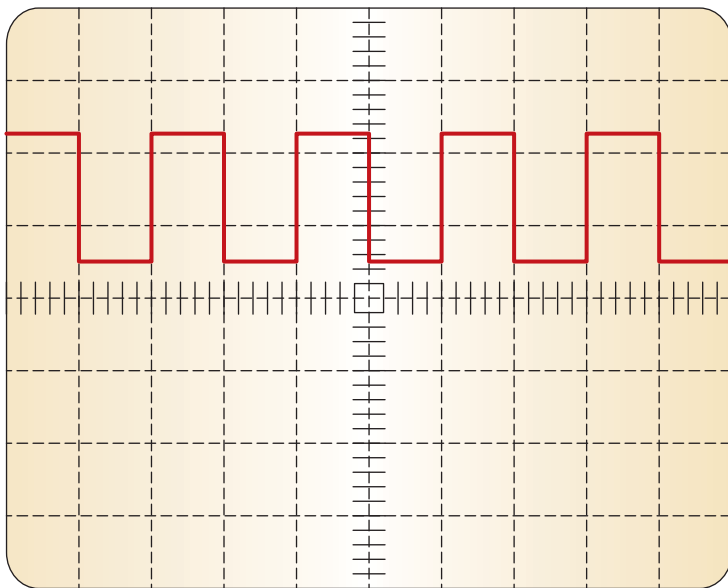
One complete sine wave is a cycle. The number of cycles that occur per second is the frequency of the signal. Checking frequency or cycle time is one way of checking the operation of some electrical components. Input sensors are the most common components that produce AC voltage. Permanent magnet voltage generators produce an AC voltage that can be checked on a scope (Figure 2-30). AC voltage waveforms should also be checked for noise and glitches. These may send false information to the computer.

DC voltage waveforms may appear as a straight line or a line showing a change in voltage. Sometimes a DC voltage waveform will appear as a **square wave**, which shows voltage making an immediate change (Figure 2-31). This type of wave represents voltage being applied (circuit being turned on), voltage being maintained (circuit remaining on), and no voltage applied (circuit is turned off). Of course, a DC voltage waveform may also show gradual voltage changes.



© Delmar/Cengage Learning

**FIGURE 2-30** An AC voltage trace from a typical permanent magnetic generator-type sensor.



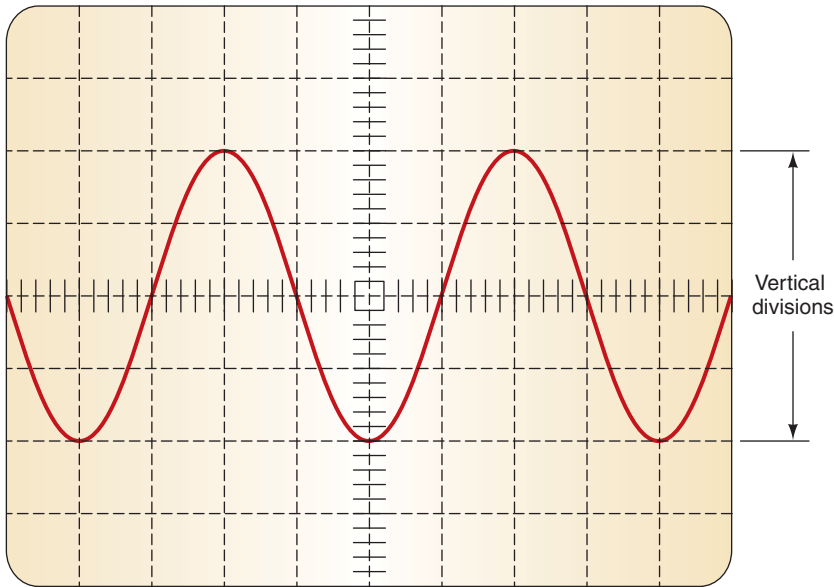
© Delmar/Cengage Learning

**FIGURE 2-31** Typical square wave.

## Scope Controls

Depending on the manufacturer and the model of the scope, the type and number of its controls will vary. However, nearly all scopes have these controls: intensity, vertical (Y-axis) adjustments, horizontal (X-axis) adjustments, and trigger adjustments. The intensity control is used to adjust the brightness of the trace. This allows for clear viewing regardless of the light around the scope screen.

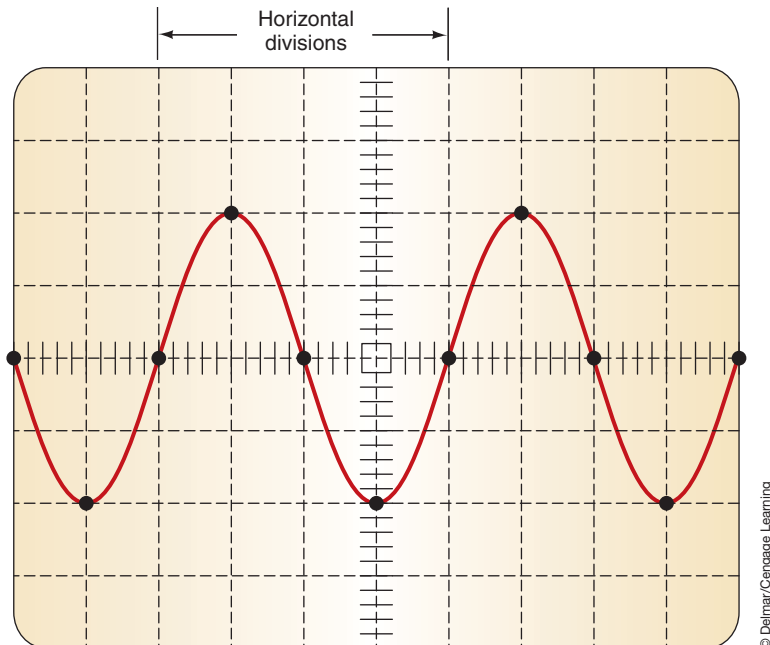
The vertical adjustment controls the voltage displayed. The voltage setting of the scope is the voltage that will be shown per division (Figure 2-32). If the scope is set at 0.5 (500 milli) volts, a 5-volt signal will need 10 divisions. Likewise, if the scope is set to 1 volt, 5 volts will need only 5 divisions. While using a scope, it is important to set the vertical so that voltage can be accurately read. Setting the voltage too low may cause the waveform to move off the



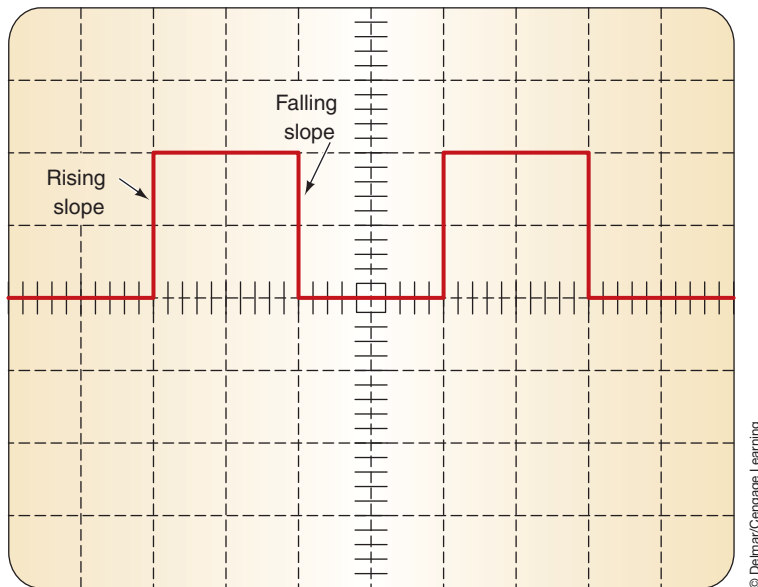
**FIGURE 2-32** Vertical divisions represent voltage.

screen, while setting it too high may cause the trace to be flat and unreadable. The vertical position control allows the vertical position of the trace to be moved anywhere on the screen.

The horizontal position control allows the horizontal position of the trace to be set on the screen. The horizontal control is actually the time control of the trace (Figure 2-33). Setting the horizontal control is setting the time base of the scope's sweep rate. If the time per division is set too low, the complete trace may not show across the screen. Also, if the time per division is set too high, the trace may be too crowded for detailed observation. The time per division (TIME/DIV) can be set from very short periods of time (millionths of a second) to full seconds.



**FIGURE 2-33** Horizontal divisions represent time.



**FIGURE 2-34** A trigger can be set to start the trace with a rise or fall of voltage.

© Delmar/Cengage Learning

Trigger controls tell the scope when to begin a trace across the screen. Setting the trigger is important when trying to observe the timing of something. Proper triggering will allow the trace to repeatedly begin and end at the same points on the screen. There are usually numerous trigger controls on a scope. The trigger mode selector has a NORM and AUTO position. In the NORM setting, no trace will appear on the screen until a voltage signal occurs within the set time base. The AUTO setting will display a trace regardless of the time base.

Slope and level controls are used to define the actual trigger voltage. The slope switch determines whether the trace will begin on a rising or falling of the voltage signal (Figure 2-34). The level control determines where the time base will be triggered according to a certain point on the slope.

A trigger source switch tells the scope which input signal to trigger on. This can be Channel 1, Channel 2, line voltage, or an external signal. External signal triggering is very useful when observing a trace of a component that may be affected by the operation of another component. An example of this would be observing fuel injector activity when changes in throttle position are made. The external trigger would be voltage change at the throttle position sensor. The displayed trace would be the cycling of a fuel injector. Channel 1 and Channel 2 inputs are determined by the points of the circuit being probed. Some scopes have a switch that allows inputs from both channels to be observed at the same time or alternately.

## SCAN TOOLS

The introduction of power train computer controls brought with it the need for tools capable of troubleshooting electronic control systems. There are a variety of computer **scan tools** available today that do just that (Figure 2-35). Connected to the computer through diagnostic connectors, a scan tool can access diagnostic trouble codes (DTCs), run tests to check system operations, and monitor the activity of the system. Trouble codes and test results are displayed on an LED screen or printed out on the scanner printer.

A scan tool receives its testing information from one of several sources. Some scan tools have a programmable read-only memory (PROM) chip that contains all the information needed to diagnose specific model lines. This chip is normally contained in a cartridge, which is plugged into the tool. The type of vehicle being tested determines the appropriate cartridge that should be inserted. These cartridges contain the test information for that particular car.



### SPECIAL TOOLS

Scan tool





© Delmar/Cengage Learning

**FIGURE 2-35** A typical handheld scan tester.

A cartridge is typically needed for each make and model vehicle. As new systems are introduced on new car models, a new cartridge is made available.

Scan testers have the capability to test many onboard computer systems such as engine computers, antilock brake computers, air bag computers, and suspension computers, depending on the year and make of vehicle and the type of scan tester. In many cases, the technician must select the computer system to be tested with the scan tester after the tester is connected to the vehicle.

The scan tester is connected to specific diagnostic connectors on various vehicles. Some manufacturers have one diagnostic connector and they connect the data wire from each onboard computer to a specific terminal in this connector. Other vehicle manufacturers have several different diagnostic connectors on each vehicle and each of these connectors may be connected to one or more onboard computers. A set of connectors is supplied with the scan tester to allow tester connection to various diagnostic connectors on different vehicles.

The scan tester must be programmed for the model year, make of vehicle, and type of engine. With some scan testers, this selection is made by pressing the appropriate buttons on the tester as directed by the digital tester display. On other scan testers, the appropriate memory card must be installed in the tester for the vehicle being tested. Some scan testers have a built-in printer to print test results, while other scan testers may be connected to an external printer.

As automotive computer systems become more complex, the diagnostic capabilities of scan testers continue to expand. Many scan testers now have the capability to store, or “freeze,” data into the tester during a road test and then play back this data when the vehicle is returned to the shop.

Some scan testers now display diagnostic information based on the fault code in the computer memory. Service bulletins published by the scan tester manufacturer may be indexed by the tester after the vehicle information is entered in the tester. Other scan testers will display sensor specifications for the vehicle being tested.

## Scan Tester Features

Scan testers display data and **diagnostic trouble codes (DTCs)** associated with the operation of computer systems and perform many other diagnostic functions. Diagnostic trouble codes (DTCs) are fault codes that represent a circuit failure in a monitored system. On many vehicles, scan testers have the capability to diagnose various computer systems such as engine,

transmission, antilock brake system (ABS), suspension, and air bag. Scan testers vary depending on the manufacturer, but many scan testers have the following features:

1. A display window displays data and messages to the technician. Messages are displayed from left to right. Most scan testers display at least four readings at the same time.
2. A memory cartridge that plugs into the scan tester. These memory cartridges are designed for specific vehicles and electronic systems. For example, a different cartridge may be required for the transmission computer and the engine computer. Most scan tester manufacturers supply memory cartridges for domestic and imported vehicles.
3. A power cord that connects from the scan tester to the battery terminals or cigarette lighter socket.
4. An adapter cord that plugs into the scan tester and connects to the data link connector (DLC) on the vehicle (Figure 2-36). A special adapter cord is supplied with the tester for the diagnostic connector on each make of vehicle.
5. A serial interface for connecting optional devices, such as a printer, terminal, or personal computer.
6. A keypad that allows the technician to enter data and reply to tester messages.

Typical keys that may be on a scan tester include:

1. Numbered keys covering digits 0 through 9.
2. Horizontal or vertical arrow keys that allow the technician to move backward and forward through test modes and menus.
3. ENTER keys to enter information into the tester.
4. PAGE BACK key that allows the technician to interrupt the current procedure and go back to the previous modes.
5. “F” keys to allow the technician to perform special functions described in the scan tester manufacturer’s manuals.
6. MORE key that allows the technician to obtain additional diagnostic information from the scan tester software.
7. YES and NO keys to allow the technician to select or reject specific procedures.



© Delmar/Cengage Learning

**FIGURE 2-36** The scan tester connects to the diagnostic link connector (DLC).



**WARNING:** The tester manufacturer's and vehicle manufacturer's recommended scan tester diagnostic procedures must be followed while diagnosing computer systems. Improper test procedures may result in scan tester damage and computer system damage.



**CAUTION:**

Always keep scan tester leads away from rotating parts such as belts and fan blades. Personal injury or property damage may result if scan tester leads become tangled in rotating parts.

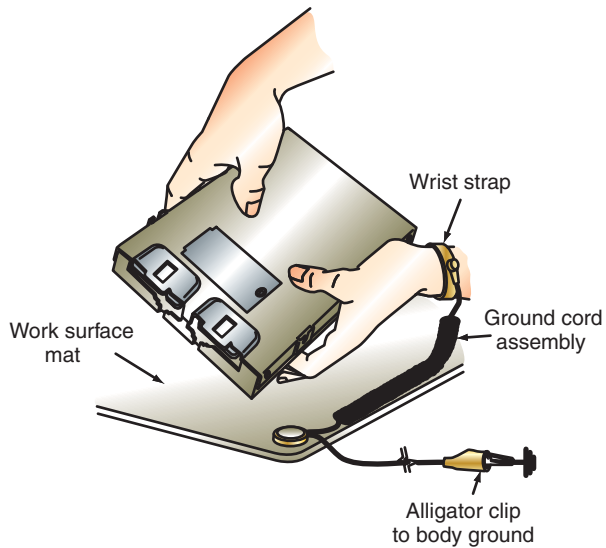
The advantages offered by the use of a scan tool include:

1. A scan tester provides quick access to data from various on-board computers. Some vehicles have several diagnostic link connectors (DLCs) to which the scan tester must be connected to access data from a specific computer. For example, some vehicles have separate DLCs to access the powertrain control module (PCM) and antilock brake system (ABS) computer data. Vehicles that have on-board diagnostic (OBD II) systems have a central DLC and data links from the various on-board computers to this DLC. Accessing this computer data greatly reduces diagnostic time.
2. A wide variety of modules are available for many scan testers. These modules allow the same scan tester to display data from many vehicles, including imported vehicles. Some scan tester modules access service bulletin information related to engine and transmission problems. This information is available in a book published by the scan tester manufacturer.
3. The vehicle can be driven on a road test with the scan tester connected to the DLC. This allows the technician to observe computer data during various operating conditions when a specific problem may occur. Most scan testers have a snapshot capability which freezes computer data into the scan tester memory for a specific period of time. This data may be played back after the technician returns to the shop.
4. Most scan testers can be connected to a printer and a copy of the scan tester data can be printed. This allows improved communication between the customer, service writer, and the technician.
5. A scan tester can be connected to a personal computer (PC). This connection allows data to be transferred from the scan tester to the PC. This data may be saved and recalled at a future time. With a computer modem, this information may be transferred to an off-site diagnostic center for analysis.

## STATIC STRAP

You are probably familiar with static charges in one form or another. The most common experience with static electricity is when you slide your feet across a carpeted floor and then touch something. You might feel and see a slight static discharge. The action of sliding your feet across the carpet placed a slight electrical charge on you. A change in the number of electrons on you puts you at a different charge level than the objects around you. When you touch them, there is a discharge between you and the object. Although this discharge generally does nothing to you other than to perhaps surprise you, it can do potentially great damage to electronic circuitry. Today's technicians must realize that static electricity will have to be discharged safely before they begin working on an electronic component or processor.

To effectively work on these circuits, some precautions are necessary. Generally these can be summarized by the statement that you must be at the same electrical potential as the component you are working on and the vehicle you are working in. Many manufacturers suggest the use of static straps that connect the technician, the component, and the ground system of the vehicle together (Figure 2-37). The theory behind this is to place all things that will touch at the same electrical potential so that a discharge will not take place. Even if you do not have all the special static straps, run jumper ground wires between the components and the vehicle, and ground yourself to the vehicle before you begin working.



**FIGURE 2-37** Static straps are needed to protect electronic devices.



**CAUTION:**

Reduce electrical load prior to connecting the memory keeper. Close all doors and make sure the ignition is in the OFF position.

**MEMORY KEEPERS**

Memory keepers, or battery backups, maintain the computer’s memory when the battery is disconnected for service. Such components as radio presets, clock settings, memory seat positions, and computer functions are lost when the battery is disconnected. A simple memory keeper (Figure 2-38) plugs into the power outlet (cigarette lighter) socket, and a 9-volt battery will keep the settings for up to 4 hours. These devices should not be used if service is being performed to the air bag system.

**SERVICE INFORMATION**

With today’s complex electrical systems, it would be impossible to repair every customer concern that is brought into the service bay without having the proper service information. The service information (in either paper form or electronic format) is one of the most



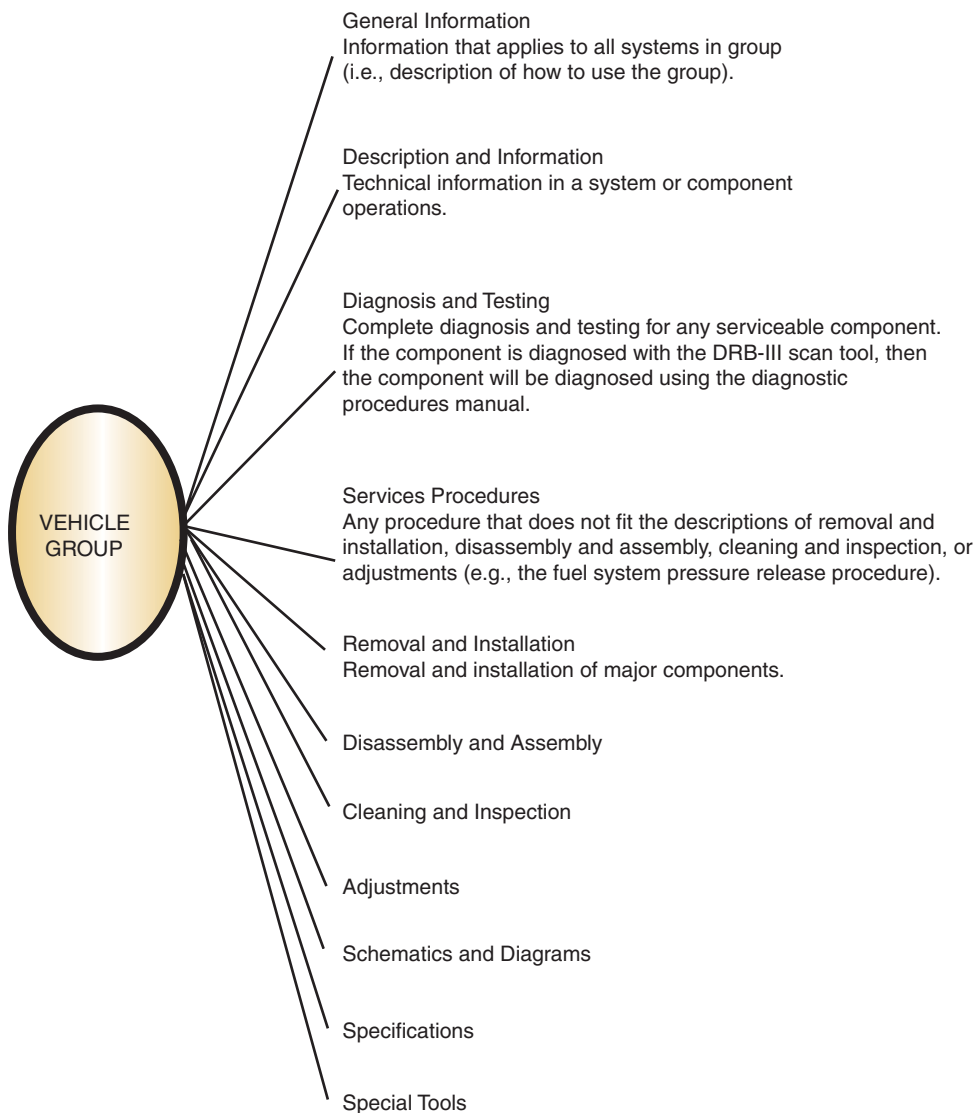
**FIGURE 2-38** A memory keeper will keep the computer memories operational while the battery is disconnected.

important and valuable tools for today's technician. It provides information concerning system description, service procedures, specifications, and diagnostic information. In addition, the service information provides information concerning wiring harness connections and routing, component location, and fluid capacities. Service information can be supplied by the vehicle manufacturer or through aftermarket suppliers.

It is also important to stay current with updated service information. This is usually published as Technical Service Bulletins (TSBs). These documents may provide information concerning fixes for a problem, new part numbers to replace a defective unit, corrections to service informations, and general information of system operation.

To obtain the correct information, you must be able to identify the engine you are working on. This may involve using the vehicle's VIN number. This number has a code for model year and engine. Which numbers are used varies between manufacturers, but the service information will provide instructions for proper VIN usage.

In the past, each manufacturer and manual publisher used its own method of organizing its manuals. Recent guidelines now require manufacturer service informations to have a standard organization (Figure 2-39).



**FIGURE 2-39** Service information uses a uniform layout.

© Delmar/Cengage Learning



Procedural information provides the steps necessary to perform the task. Most service manuals provide illustrations to guide the technician through the task. To get the most out of the service manual, you must use the correct manual for the vehicle and system being worked on, and follow each step in order. Some technicians lead themselves down the wrong trail by making assumptions and skipping steps.

Torque, end play, and clearance specifications may be located within the text of the procedural information. In addition, specifications may be provided in a series of tables. The heading above the table provides a quick reference to the type of specification information being provided.

Diagnostic procedures are often presented in a chart form or a tree (Figure 2-40). The tree guides you through the process as system tests are performed. The result of a test then directs you to a branch. Keep following the steps until the problem is isolated.

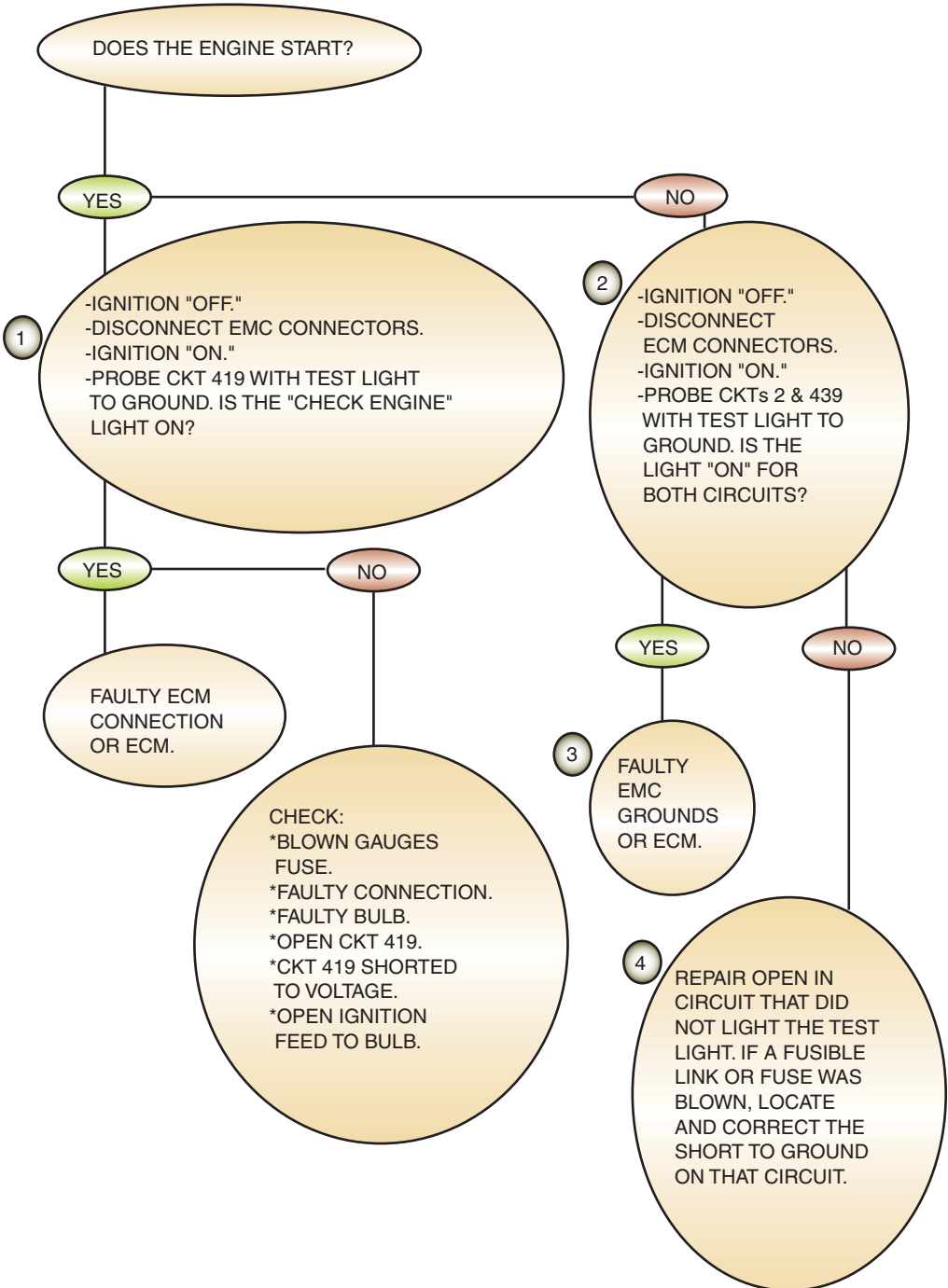
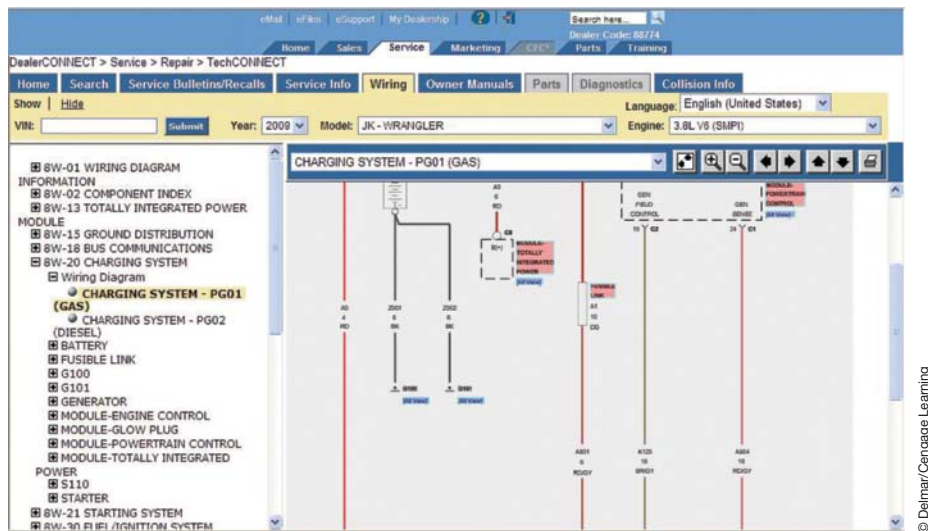


FIGURE 2-40 A diagnostic tree leads the technician to the cause of the fault.





**FIGURE 2-41** Computerized service information and web-based materials retrieval systems are replacing paper service informations.

Since the service manual is divided into several major component areas, a table of contents is provided for easy access to the information. Each component area of the vehicle is covered under a section in the service information. Using the table of contents identifies the section to turn to. Once in the appropriate section, a smaller, more specific table of contents will direct you to the page on which the information is located. Due to the extensive amount of information provided in service informations and the number of component areas, the manual may be divided into several volumes.

Today, most service and parts information is provided through computer services (Figure 2-41). This is a popular method since libraries of service informations can take large areas of space. Computerized systems can have the information stored on disks, or the computer can be connected to a central database. The computer system helps the technician find the required information quicker and easier than in a book-type manual. Using the computer keyboard, light pen, touch-sensitive screen, or mouse, the technician makes choices from a series of menus on the monitor. If needed, the information can be printed to paper.

Another tool that can be of assistance to the technician is hotline services. There are many companies and organizations that provide online assistance to technicians. The hotline assistants use database information, along with factory service manuals, TSBs, and other sources to help the technician repair the vehicle.

Also, some companies and organizations provide a service of tracking the service history of vehicles. Manufacturers will generally do this for any of their vehicles that is serviced in one of their dealerships. This information lets the technician know if service has been performed on the vehicle that may be related to the present problem. Also, some Web site organizations will track if the vehicle has ever been “totaled” in an accident, stolen, or caught in a flood.

## WORKING AS AN ELECTRICAL SYSTEMS TECHNICIAN

To be a successful automotive technician, you need to have good training, a desire to succeed, and a commitment to becoming a good technician and a good employee. A good employee works well with others and strives to make the business successful. The required training is not just in the automotive field. Good technicians need to have good reading, writing, and math skills. These skills will allow you to better understand and use the material found in service manuals and textbooks, as well as provide you with the basics for good communications with customers and others.

## Compensation

Technicians are typically paid according to their abilities. Most often, new or apprentice technicians are paid by the hour. While being paid they are learning the trade and the business. Time is usually spent working with master technicians or doing low-skill jobs. As apprentices learn more, they can earn more and take on more complex jobs. Once technicians have demonstrated a satisfactory level of skills, they can go on **flat rate**.

Flat rate is a pay system in which technicians are paid for the amount of work they do. Each job has a flat rate time. Pay is based on that time, regardless of how long it took to complete the job. To explain how this system works, let's look at a technician who is paid \$15.00 per flat rate hour. If a job has a flat rate time of 3 hours, the technician will be paid \$45.00 for the job, regardless of how long it took to complete. Experienced technicians beat the flat rate time nearly all of the time. Their weekly pay is based on the time "turned in," not on the time spent. If the technician turns in 60 hours of work in a 40-hour workweek, he or she actually earned \$22.50 each hour worked. However, if he or she turned in only 30 hours in the 40-hour week, the hourly pay is \$11.25.

The flat rate system favors good technicians that work in a shop that has a large volume of work. The use of flat rate times allows for more accurate repair estimates to the customers. It also rewards skilled and productive technicians.

## Workplace Relationships

When you begin a job, you enter into a business agreement with your employer. When you become an employee, you sell your time, skills, and efforts. In return, your employer pays you for these resources. As part of the employment agreement, your employer also has certain responsibilities:

- **Instruction and Supervision**—You should be told what is expected of you. A supervisor should observe your work and tell you if it is satisfactory and offer ways to improve your performance.
- **A Clean, Safe, Place to Work**—An employer should provide a clean and safe work area as well as a place for personal cleanup.
- **Wages**—You should know how much you are to be paid, what your pay will be based on, and when you will be paid before accepting a job.
- **Fringe Benefits**—When hired, you should be told what benefits to expect, such as paid vacations and employer contributions to health insurance and retirement plans.
- **Opportunity**—You should be given a chance to succeed and possibly advance within the company.
- **Fair Treatment**—All employees should be treated equally, without prejudice or favoritism.

On the other side of this business transaction, employees have responsibilities to their employers. Your obligations as an employee to the employer include the following:

- **Regular Attendance**—A good employee is reliable.
- **Following Directions**—As an employee, you are part of a team, and doing things your way may not serve the best interests of the company.
- **Responsibility**—You must be willing to answer for your behavior and work. You need to also realize that you are legally responsible for the work you do.
- **Productivity**—Remember, you are paid for your time as well as your skills and effort.
- **Loyalty**—Loyalty is expected; by being loyal you will act in the best interests of your employer, both on and off the job.

## Customer Relations

Another responsibility you have is good customer relations. Learn to listen and communicate clearly. Be polite and organized, particularly when dealing with customers. Always be as honest as you possibly can.

Look like and present yourself as a professional, which is what automotive technicians are. Professionals are proud of what they do and they show it. Always dress and act appropriately and watch your language, even when you think no one is near.

Respect the vehicles you work on. They are important to the lives of your customers. Always return the vehicle to the owner in a clean, undamaged condition. Remember, a vehicle is the second-largest expense a customer has. Treat it that way. It doesn't matter if you like the car. It belongs to the customer; treat it respectfully.

Explain the repair process to the customer in understandable terms. Whenever you are explaining something to a customer, make sure you do this in a simple way without making the customer feel stupid. Always show the customer respect and be courteous. Not only is this the right thing to do but it also leads to loyal customers.

## Communicating with the Customer

Depending on the size of the service center that you are working in, you may or may not talk directly with the customer. A service advisor or manager might be in between the consumer and you, the technician. In either case, getting the correct information from the customer cannot be overemphasized. The customer is likely the person who was driving the vehicle when the problem showed up. The conversation that someone has with the customer can be extremely useful and save hours of fruitless work. A repair ticket that states "drivability problem" will require the technician to figure out the driving conditions that were present when the problem occurred. It is possible that the technician will not be able to duplicate the conditions and not observe the problem. The vehicle is returned to the consumer with the note of "no problem found." Think about how frustrating this could be, especially if the customer experiences the problem the very next day. The conversation with the customer should have revealed important information for the technician. When did the problem occur? What specifically did the vehicle do or not do? What was the outside temperature? Was the engine warm or cold? What driving conditions produced the problem? Can you duplicate the problem with the technician in the vehicle?

Think about how much more information the technician has in the second example. It is likely that less time will be necessary to fix the vehicle because the technician has a starting point. Once you get out in the field, try to develop your communication skills and especially your ability to listen to the customer. The customer's information, if you have heard it, will save you countless hours of frustration and no doubt result in a better repair. Better repairs bring customers back to the service center the next time they need service.

## Completing a Work Order

The **work order** is a contract between the customer and the shop to have specified service performed. In larger shops, a service writer is employed to have contact with the customer and to begin the work order process. In smaller shops, the technician may be required to also write up the work order. Regardless of who is responsible for the write up, a work order must be written for every vehicle that is brought to the shop for repairs.

The work order must contain certain information (Figure 2-42). This includes information about the customer, the customer's vehicle, and the customer's concern or service request. In addition, estimates of cost to perform the service are included on the work order along with estimated date and time the work will be completed.

**AUTHOR'S NOTE: The work order is also referred to as a Repair Order.**

The work order is a legal document that is an agreement to provide services and legally protects both the customer and the shop. The work order is signed by the customer who



Today, most service facilities use a form of shop management software. The information for the completion of the work order is inputted using the computer's keyboard. The software package also helps in the estimation of repair costs. The software also takes information from the work order and saves it in various files, each defined by its purpose.

One of the responsibilities of the technician is to document the cause and correction of the concern. It may not be possible to provide an estimate to the customer at the time of the original write up since the problem has not been diagnosed yet. At this time the customer agrees to pay the shop to perform the diagnostic routine. Often a limit is agreed upon by the parties. Once the problem has been identified and the root cause is determined, the cost of the repair must be estimated and the customer gives approval. The cause of the complaint needs to be documented in such a manner that the customer and service writer understand what the issue was. The correction actions are documented for purposes of warranty. Whatever the repair entailed is to be recorded. For example, if a wire was repaired, document this repair and the location of the repair. If parts are installed, list the parts.

## ASE Certification

An obvious sign of your knowledge and abilities, as well as your dedication to the trade, is ASE certification. The National Institute for Automotive Service Excellence (ASE) has established a voluntary certification program for automotive, heavy-duty truck, auto body repair, and engine machine shop technicians. In addition to these programs, ASE also offers individual testing in some specialty areas. This certification system combines voluntary testing with on-the-job experience to confirm that technicians have the skills needed to work on today's vehicles (Figure 2-43). ASE recognizes two distinct levels of service capability—the automotive technician and the master automotive technician.

After passing at least one exam and providing proof of two years of hands-on work experience, you become ASE certified. Retesting is necessary every five years to remain certified. A technician who passes one examination receives an automotive technician shoulder patch. The master automotive technician patch is awarded to technicians who pass all eight of the basic automotive certification exams. You may receive credit for one of the two years by substituting relevant formal training in one, or a combination, of the following:

- High school training. Three years of training may be substituted for one year of experience.
- Post-high school training. Two years of post-high school training in a trade school, technical institute, or community college may be counted as one year of work experience.



© Delmar/Cengage Learning

**FIGURE 2-43** ASE certification communicates your pride in your profession to the customers.



- Short courses. For shorter periods of post–high school training you may substitute two months of training for one month of work experience.
- Apprenticeship programs. You may receive full credit for the experience requirement by satisfactorily completing a three- or four-year apprenticeship program.

Each certification test consists of 40 to 80 multiple-choice questions. The questions are written by a panel of technical service experts, including domestic and import vehicle manufacturers, repair and test equipment and parts manufacturers, working automotive technicians, and automotive instructors. All questions are pretested and quality checked on a national sample of technicians before they are included in the actual test. Many test questions force the student to choose between two distinct repair or diagnostic methods. The test questions focus on basic technical knowledge, repair knowledge and skill, and testing and diagnostic knowledge and skill.

## Diagnosics

The true measure of a good technician is an ability to find and correct the cause of problems. Service manuals and other information sources will guide you through the diagnosis and repair of problems, but these guidelines will not always lead you to the exact cause of the problem. To do this you must use your knowledge and take a logical approach while troubleshooting. Diagnosis is not guessing, and it's more than following a series of interrelated steps in order to find the solution to a specific problem. Diagnosis is a way of looking at systems that are not functioning the way they should and finding out why. It is knowing how the system should work and deciding if it is working correctly. Through an understanding of the purpose and operation of the system, you can accurately diagnose problems.

Most good technicians use the same basic diagnostic approach. Simply because this is a logical approach, it can quickly lead to the cause of a problem. Logical diagnosis follows these steps:

1. Gather information about the problem.
2. Verify that the problem exists.
3. Thoroughly define what the problem is and when it occurs.
4. Research all available information and knowledge to determine the possible causes of the problem.
5. Isolate the problem by testing.
6. Continue testing to pinpoint the cause of the problem.
7. Locate and repair the problem.
8. Verify the repair.

## SUMMARY

---

- A test light is used when the technician needs to “look” for electrical power in the circuit. The test light allows the technician to see if current is at a point in the circuit by lighting the light.
- A logic probe provides a means for testing voltages on electronic circuits without damaging the circuit.
- Digital multimeters (DMM) display values using liquid crystal displays instead of a swinging needle. They are computers that determine the measured value and display it for the technician.
- A voltmeter measures the voltage potential between two points in a circuit.
- An ohmmeter is used to measure the resistance of a circuit or part of a circuit.



## SUMMARY

---

- An ammeter is a special meter used to measure current flow in a circuit.
- Electrical noise is an unwanted voltage signal that rides on a signal. Noise is usually the result of radio frequency interference (RFI) or electromagnetic induction (EMI).
- Duty cycle is the percentage of on time the circuit component is turned on as compared to the total time of the cycle.
- A cycle is one set of changes in a signal that repeats itself several times.
- Pulse width is the amount of time, measured in milliseconds, that a component is turned on.
- Frequency is a measure of the number of cycles that occur in one second.
- Hertz is the measurement of frequency.
- A lab scope provides a visual display of electrical waves.
- Glitches may be the result of momentary shorts to ground, shorts to power, or opens in the circuit.
- A sine wave is a waveform that shows voltage-changing polarity from positive to negative.
- Having straight vertical sides and a flat top indicating a fast-acting on-off voltage state identifies a square wave pattern.
- Scan tools interface with the vehicle's computer system to allow the technician to "talk" with the computers.
- The service manual (in either paper form or electronic format) is one of the most important and valuable tools for today's technician.
- The service manual provides information concerning engine identification, service procedures, specifications, and diagnostic information.
- Technical Service Bulletins (TSBs) may provide information concerning fixes for a problem, new part numbers to replace a defective unit, corrections to service manual information, and general information of system operation.
- Service manual procedural information provides the steps necessary to perform the task.
- Since the service manual is divided into several major component areas, a table of contents is provided for easy access to the information.
- Service and parts information can also be provided through computer services.
- Technicians are typically paid according to their abilities. New or apprentice technicians are paid by the hour. Once technicians have demonstrated a satisfactory level of skills, they can go on flat rate.
- When you begin a job, you enter into a business agreement with your employer. When you become an employee, you sell your time, skills, and efforts. In return, your employer pays you for these resources.
- As part of the employment agreement, your employer also has certain responsibilities: instruction and supervision; a clean, safe place to work; wages; fringe benefits; opportunity; and fair treatment.
- Your obligations as an employee to the employer include regular attendance, following directions, responsibility, productivity, and loyalty.
- When communicating with customers, be polite, respectful, organized, and honest.
- An obvious sign of your knowledge and abilities, as well as your dedication to the trade is ASE certification.
- The work order is a contract between the customer and the shop to have specified service performed.
- The true measure of a good technician is an ability to find and correct the cause of problems.
- Diagnosis is not guessing, and it is more than following a series of interrelated steps in order to find the solution to a specific problem.

## TERMS TO KNOW

Ammeter  
Average responding  
Backprobe  
Captured signal  
Cycle  
D'Arsonval movement  
Diagnostic trouble codes (DTCs)  
Digital multimeter (DMM)  
Duty cycle  
Flat rate  
Frequency  
Glitches  
Hertz  
Jumper wire  
Logic probe  
Multimeter  
Noise  
Ohmmeter  
Pulse width  
Root mean square (RMS)  
Scan tool  
Sine wave  
Sinusoidal  
Square wave  
Test light  
Voltage drop  
Voltmeter  
Work order

## ASE-STYLE REVIEW QUESTIONS

- Technician A* says a test light is ideal for checking for voltage on a low-current, low-power circuit.  
*Technician B* says to use an analog multimeter to test computer-controlled circuits.  
Who is correct?

A. A only                      C. Both A and B  
B. B only                      D. Neither A nor B
- The use of an ammeter is being discussed.  
*Technician A* says the ammeter is used to measure current flow.  
*Technician B* says the ammeter must be connected in parallel to the circuit being tested.  
Who is correct?

A. A only                      C. Both A and B  
B. B only                      D. Neither A nor B
- A DVOM is being used to measure current flow. The meter is displaying 85.5 mA.  
*Technician A* says this represents 0.0855 amperes.  
*Technician B* says the decimal point needs to be moved six points to the left.  
Who is correct?

A. A only                      C. Both A and B  
B. B only                      D. Neither A nor B
- Technician A* says a 10% duty cycle indicates that the load device is turned on most of the time.  
*Technician B* says the pulse width is measured in degrees.  
Who is correct?

A. A only                      C. Both A and B  
B. B only                      D. Neither A nor B
- A vehicle is being tested for a draw against the battery with the ignition switch in the OFF position. The specifications state the draw should be between 10 and 30 milliamps. The DVOM reads 0.251 amps.  
*Technician A* says this draw is within the specification range.  
*Technician B* says the draw is too high.  
Who is correct?

A. A only                      C. Both A and B  
B. B only                      D. Neither A nor B
- Technician A* says that after an individual passes a particular ASE-certification exam, he or she is certified in that test area.  
*Technician B* says that all of the questions on an ASE-certification exam are written as *Technician A* and *Technician B* questions.  
Who is correct?

A. A only                      C. Both A and B  
B. B only                      D. Neither A nor B
- Technician A* says a voltmeter that is connected in parallel to the load device will indicate the voltage drop across the device.  
*Technician B* says that a ohmmeter reading of 0.00  $\Omega$  when connected in parallel to the coil of an A/C compressor indicates the coil is shorted.  
Who is correct?

A. A only                      C. Both A and B  
B. B only                      D. Neither A nor B
- Technician A* says the upward voltage traces on an oscilloscope screen indicate a specific length of time.  
*Technician B* says the cathode ray tube (CRT) in an oscilloscope is like a very-fast-reacting voltmeter.  
Who is correct?

A. A only                      C. Both A and B  
B. B only                      D. Neither A nor B
- The best way of determining if a switch is faulty is being discussed.  
*Technician A* says to use a jumper wire to bypass the switch and to connect the various circuits controlled by the switch.  
*Technician B* says to use an ammeter to test continuity through the switch.  
Who is correct?

A. A only                      C. Both A and B  
B. B only                      D. Neither A nor B
- Technician A* says the service manual (in either paper form or electronic format) is one of the most important and valuable tools for today's technician.  
*Technician B* says service bulletins (TSBs) provide information concerning fixes for a problem, new part numbers to replace a defective unit, corrections to service manual information, and general information of system operation.  
Who is correct?

A. A only                      C. Both A and B  
B. B only                      D. Neither A nor B

## ASE CHALLENGE QUESTIONS

- Technician A* says a voltmeter measures the electrical potential between two points of the circuit.  
*Technician B* says that an ammeter reading of 0.00 when connected in series to a circuit indicates a short to ground.  
Who is correct?

A. A only            C. Both A and B  
B. B only            D. Neither A nor B
- A scanner allows a technician to:

A. measure circuit resistance.  
B. determine load voltage drop.  
C. view computer inputs.  
D. load test the battery.
- All of the following are true concerning the use of an ohmmeter EXCEPT:

A. Connect the ohmmeter with the circuit power off.  
B. An "OL" indicates that the reading is over limits.  
C. 0.00 indicates no resistance.  
D. Connect the test leads of the meter in series to the load.
- The signal-output of a throttle position sensor is being checked (from idle to the wide-open throttle position) with an oscilloscope. The test lead is set to the 10x position. Which of the following represents the correct position of the vertical adjustment selector?

A. 0.1 Volt            C. 2 Volts  
B. 0.5 Volt            D. 5 Volts
- Technician A* says that logic probes can be very helpful in testing analog signals.  
*Technician B* says the nonpowered test lights should not be used to test most computer circuits.  
Who is correct?

A. A only            C. Both A and B  
B. B only            D. Neither A nor B
- The insulation test function is being discussed.  
*Technician A* says that the test is performed with the circuit powered.  
*Technician B* says the meter displays the circuit's voltage.  
Who is correct?

A. A only            C. Both A and B  
B. B only            D. Neither A nor B
- All of the following concerning the use of jumper wires are true EXCEPT:

A. The jumper wire should be fused.  
B. The jumper wire can be used to bypass a switch.  
C. The jumper wire can be used to bypass the load device.  
D. The jumper wire can be used to supply an alternate ground circuit.
- When a connector is unplugged and applied voltage is measured, the reading is battery voltage.  
*Technician A* says this means the circuit is good.  
*Technician B* says that an open circuit voltage test does not indicate if the circuit has resistance.  
Who is correct?

A. A only            C. Both A and B  
B. B only            D. Neither A nor B
- While using a test light to check for voltage, the light comes on bright.  
*Technician A* says this indicates that the circuit can handle the load that is required by the test light.  
*Technician B* says the amperage to turn the light on is dependent on the type and rating of the bulb.  
Who is correct?

A. A only            C. Both A and B  
B. B only            D. Neither A nor B
- Which of the following statement is most correct?

A. Voltage drop testing tests the circuit under load.  
B. An ammeter must be connected in parallel to the load.  
C. An ohmmeter tests the circuit under a simulated load.  
D. An insulation meter is used to measure high voltage.

*This page intentionally left blank*

Name \_\_\_\_\_ Date \_\_\_\_\_

## USING OHM'S LAW TO CALCULATE ELECTRICAL PROPERTIES

Using Ohm's law, solve the following problems:

### Exercise 1—Series Circuit

Refer to the circuit presented below.

Use Ohm's law to calculate the following values, when  $R_1 = 2$  ohms and  $R_2 = 4$  ohms:

Total circuit resistance = \_\_\_\_\_ ohms

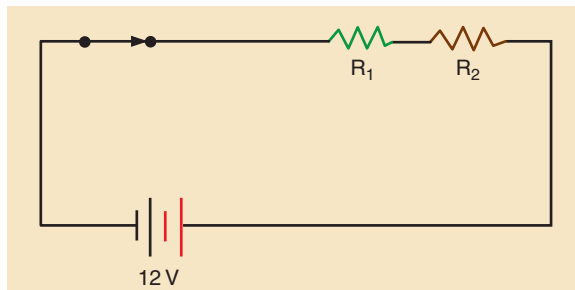
Circuit current = \_\_\_\_\_ amps

Current through  $R_1$  = \_\_\_\_\_ amps

Current through  $R_2$  = \_\_\_\_\_ amps

Voltage drop across  $R_1$  = \_\_\_\_\_ volts

Voltage drop across  $R_2$  = \_\_\_\_\_ volts



© Delmar/Cengage Learning

If the resistance of  $R_1$  increases to 8 ohms, what are the new values?

Total circuit resistance = \_\_\_\_\_ ohms

Circuit current = \_\_\_\_\_ amps

Current through  $R_1$  = \_\_\_\_\_ amps

Current through  $R_2$  = \_\_\_\_\_ amps

Voltage drop across  $R_1$  = \_\_\_\_\_ volts

Voltage drop across  $R_2$  = \_\_\_\_\_ volts

### Exercise 2—Series Circuit

Refer to the circuit provided below.

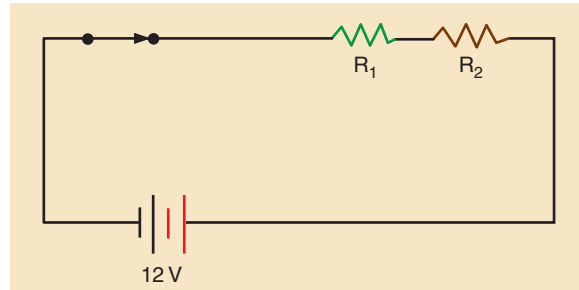
Use Ohm's law to calculate the following values, when  $R_1 = 3$  ohms and  $R_2 = 6$  ohms:

Total circuit resistance = \_\_\_\_\_ ohms

Circuit current = \_\_\_\_\_ amps

Current through  $R_1$  = \_\_\_\_\_ amps

Current through  $R_2 =$  \_\_\_\_\_ amps  
 Voltage drop across  $R_1 =$  \_\_\_\_\_ volts  
 Voltage drop across  $R_2 =$  \_\_\_\_\_ volts

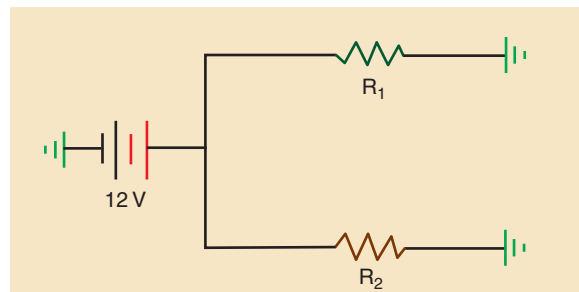


### Exercise 3—Parallel Circuit

Refer to the circuit provided below.

Use Ohm's law to calculate the following values, when  $R_1 = 12$  ohms and  $R_2 = 12$  ohms:

Total circuit resistance = \_\_\_\_\_ ohms  
 Circuit current = \_\_\_\_\_ amps  
 Current through  $R_1 =$  \_\_\_\_\_ amps  
 Current through  $R_2 =$  \_\_\_\_\_ amps  
 Voltage drop across  $R_1 =$  \_\_\_\_\_ volts  
 Voltage drop across  $R_2 =$  \_\_\_\_\_ volts



### Exercise 4—Parallel Circuit

Refer to the circuit provided below.

Use Ohm's law to calculate the following values, when  $R_1 = 1$  ohm,  $R_2 = 3$  ohms,  $R_3 = 2$  ohms, and  $R_4 = 2$  ohms:

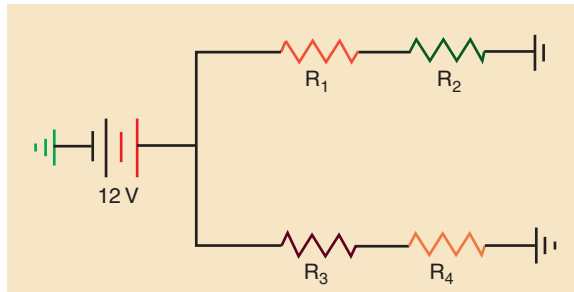
Total circuit resistance = \_\_\_\_\_ ohms  
 Circuit current = \_\_\_\_\_ amps  
 Current through  $R_1 =$  \_\_\_\_\_ amps  
 Current through  $R_2 =$  \_\_\_\_\_ amps  
 Current through  $R_3 =$  \_\_\_\_\_ amps  
 Current through  $R_4 =$  \_\_\_\_\_ amps  
 Voltage drop across  $R_1 =$  \_\_\_\_\_ volts



Voltage drop across  $R_2 =$  \_\_\_\_\_ volts

Voltage drop across  $R_3 =$  \_\_\_\_\_ volts

Voltage drop across  $R_4 =$  \_\_\_\_\_ volts



© Delmar/Cengage Learning

### Exercise 5—Parallel Circuit

Refer to the circuit on page 76.

Use Ohm's law to calculate the following values, when  $R_1 = 1$  ohm,  $R_2 = 3$  ohms,  $R_3 = 2$  ohms, and  $R_4 = 10$  ohms:

Total circuit resistance = \_\_\_\_\_ ohms

Circuit current = \_\_\_\_\_ amps

Current through  $R_1 =$  \_\_\_\_\_ amps

Current through  $R_2 =$  \_\_\_\_\_ amps

Current through  $R_3 =$  \_\_\_\_\_ amps

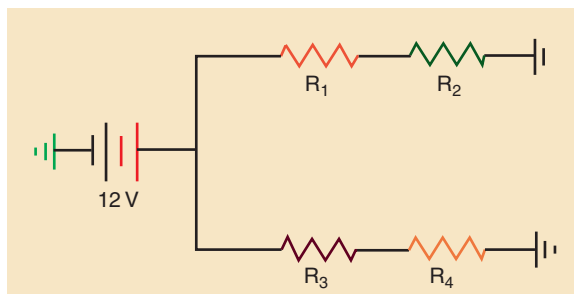
Current through  $R_4 =$  \_\_\_\_\_ amps

Voltage drop across  $R_1 =$  \_\_\_\_\_ volts

Voltage drop across  $R_2 =$  \_\_\_\_\_ volts

Voltage drop across  $R_3 =$  \_\_\_\_\_ volts

Voltage drop across  $R_4 =$  \_\_\_\_\_ volts



© Delmar/Cengage Learning

### Exercise 6—Parallel Circuit

Refer to the circuit provided below.

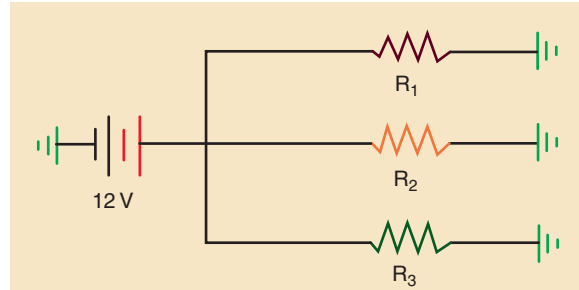
Use Ohm's law to calculate the following values, when  $R_1 = 2$  ohms,  $R_2 = 3$  ohms, and  $R_3 = 6$  ohms:

Total circuit resistance = \_\_\_\_\_ ohms

Circuit current = \_\_\_\_\_ amps

Current through  $R_1 =$  \_\_\_\_\_ amps

Current through  $R_2 =$  \_\_\_\_\_ amps  
 Current through  $R_3 =$  \_\_\_\_\_ amps  
 Voltage drop across  $R_1 =$  \_\_\_\_\_ volts  
 Voltage drop across  $R_2 =$  \_\_\_\_\_ volts  
 Voltage drop across  $R_3 =$  \_\_\_\_\_ volts



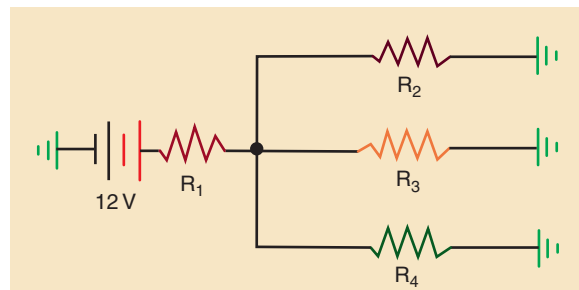
© Delmar/Cengage Learning

### Exercise 7—Series-Parallel Circuit

Refer to the circuit provided below.

Use Ohm's law to calculate the following values, when  $R_1 = 1$  ohm,  $R_2 = 2$  ohms,  $R_3 = 3$  ohms, and  $R_4 = 6$  ohms:

Total circuit resistance = \_\_\_\_\_ ohms  
 Circuit current = \_\_\_\_\_ amps  
 Current through  $R_1 =$  \_\_\_\_\_ amps  
 Current through  $R_2 =$  \_\_\_\_\_ amps  
 Current through  $R_3 =$  \_\_\_\_\_ amps  
 Current through  $R_4 =$  \_\_\_\_\_ amps  
 Voltage drop across  $R_1 =$  \_\_\_\_\_ volts  
 Voltage drop across  $R_2 =$  \_\_\_\_\_ volts  
 Voltage drop across  $R_3 =$  \_\_\_\_\_ volts  
 Voltage drop across  $R_4 =$  \_\_\_\_\_ volts



© Delmar/Cengage Learning

### Exercise 8—Series-Parallel Circuit

Refer to the circuit provided on page 78.

Use Ohm's law to calculate the following values, when  $R_1 = 6$  ohms,  $R_2 = 3$  ohms, and  $R_3 = 2$  ohms:

Total circuit resistance = \_\_\_\_\_ ohms

Circuit current = \_\_\_\_\_ amps

Current through  $R_1$  = \_\_\_\_\_ amps

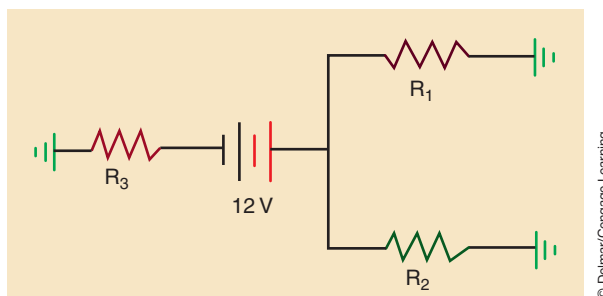
Current through  $R_2$  = \_\_\_\_\_ amps

Current through  $R_3$  = \_\_\_\_\_ amps

Voltage drop across  $R_1$  = \_\_\_\_\_ volts

Voltage drop across  $R_2$  = \_\_\_\_\_ volts

Voltage drop across  $R_3$  = \_\_\_\_\_ volts



© Delmar/Cengage Learning

Instructor's Response \_\_\_\_\_

\_\_\_\_\_

\_\_\_\_\_

*This page intentionally left blank*

Name \_\_\_\_\_ Date \_\_\_\_\_

## METER SYMBOL INTERPRETATION

Upon completion of this job sheet, you should be able to convert commonly found symbols into numeric values.

Convert the following values into the electrical units noted:

1.  $2.4 \text{ K}\Omega$  = \_\_\_\_\_  $\Omega$
2.  $954 \text{ mV}$  = \_\_\_\_\_  $\text{V}$
3.  $5.76 \text{ K}\Omega$  = \_\_\_\_\_  $\Omega$
4.  $2 \text{ mA}$  = \_\_\_\_\_  $\text{A}$
5.  $22 \text{ K}\Omega$  = \_\_\_\_\_  $\Omega$
6.  $4.5 \text{ mA}$  = \_\_\_\_\_  $\text{A}$
7.  $456 \text{ mA}$  = \_\_\_\_\_  $\text{A}$
8.  $1024 \text{ mV}$  = \_\_\_\_\_  $\text{V}$
9.  $0.786 \text{ K}\Omega$  = \_\_\_\_\_  $\Omega$
10.  $32 \text{ K}\Omega + 112 \Omega$  = \_\_\_\_\_  $\Omega$
11.  $1400 \Omega$  = \_\_\_\_\_  $\text{K}\Omega$
12.  $0.000235 \text{ A}$  = \_\_\_\_\_  $\text{mA}$
13.  $0.987 \text{ V}$  = \_\_\_\_\_  $\text{mV}$
14.  $5 \text{ K V}$  = \_\_\_\_\_  $\text{mV}$
15.  $123955 \Omega$  = \_\_\_\_\_  $\text{K}\Omega$
16.  $144,000 \text{ mA}$  = \_\_\_\_\_  $\text{A}$
17.  $126 \text{ mV} + 11.874 \text{ V}$  = \_\_\_\_\_  $\text{V}$
18.  $320,000 \Omega$  = \_\_\_\_\_  $\Omega$
19.  $0.000045 \text{ A}$  = \_\_\_\_\_  $\text{mA}$
20.  $12,600 \text{ mV}$  = \_\_\_\_\_  $\text{V}$

Instructor's Response \_\_\_\_\_

\_\_\_\_\_  
\_\_\_\_\_

*This page intentionally left blank*



Name \_\_\_\_\_ Date \_\_\_\_\_

## USING A TEST LIGHT

Upon completion of this job sheet, you should be able to properly use a test light to check continuity in electrical circuits.

### ASE Correlation

This job sheet is related to the ASE Electrical/Electronic System Certification Exam's content area: *General Electric/Electronic System Diagnosis*; task: Check continuity in electrical circuits with a test light and determine needed repairs.

### Tools and Materials

- A vehicle
- A test light
- Wiring diagrams for the vehicle

### Describe the vehicle being worked on.

Year \_\_\_\_\_ Make \_\_\_\_\_ VIN \_\_\_\_\_

Model \_\_\_\_\_ Engine type and size \_\_\_\_\_

### Procedure

Task Completed

1. Using the proper wiring diagram and your instructor's assistance, determine which wire is the positive feed and which wire is the ground for one of the low-beam headlights on your assigned vehicle. Identify the color of each wire:

Positive \_\_\_\_\_ Negative \_\_\_\_\_

2. Test proper operation of the test light by connecting the negative lead to the negative post of the battery and touching the probe tip to the positive lead of the battery. If the test light is working properly, the light should illuminate. If the light does not turn on, inform your instructor. Did the light work properly?  Yes  No

3. With the headlight switch in the OFF position, disconnect the headlight connector.

4. Connect the negative lead of the test light to a good ground. Locate the probe of the test light into the connector cavity identified as positive feed. Did the test light come on?  Yes  No

Explain your results: \_\_\_\_\_  
 \_\_\_\_\_  
 \_\_\_\_\_

5. Turn the headlight switch into the ON position and retest the circuit again. Did the test light come on?  Yes  No

---

Task Completed

6. Turn the headlight switch OFF.

7. Move the wire clip of the test light to the positive post of the battery and locate the probe into the cavity identified as the ground. Does the test light come on?

Yes  No

Explain the reason: \_\_\_\_\_

\_\_\_\_\_

\_\_\_\_\_

Instructor's Response \_\_\_\_\_

\_\_\_\_\_

\_\_\_\_\_

Name \_\_\_\_\_ Date \_\_\_\_\_

## USE OF A VOLTMETER

Upon completion of this job sheet, you should be able to measure available voltage and voltage drop.

### ASE Correlation

This job sheet is related to the ASE Electrical/Electronic System Certification Exam's content area: *General Electrical/Electronic System Diagnosis*; task: Check applied voltages and voltage drops in electrical/electronic circuits and components with a voltmeter; determine needed repairs.

### Tools and Materials

A vehicle            Wiring diagram for vehicle  
A DMM              Basic hand tools

### Describe the vehicle being worked on.

Year \_\_\_\_\_ Make \_\_\_\_\_ VIN \_\_\_\_\_

Model \_\_\_\_\_ Engine type and size \_\_\_\_\_

### Procedure

Task Completed

1. Set the DMM to the appropriate scale to read 12 volts DC.
2. Connect the meter across the battery (positive to positive and negative to negative).  
What is your reading on the meter? \_\_\_\_\_ volts
3. With the meter still connected across the battery, turn on the headlights of the vehicle.  
What is your reading on the meter? \_\_\_\_\_ volts
4. Keep the headlights on. Connect the positive lead of the meter to the point on the vehicle where the battery's ground cable attaches to the frame. Keep the negative lead where it is.  
What is your reading on the meter? \_\_\_\_\_ volts  
What is being measured? \_\_\_\_\_
5. Disconnect the meter from the battery and turn off the headlights.
6. Refer to the correct wiring diagram and determine what wire at the right headlight delivers current to the lamp when the headlights are on and low beams selected.  
Color of the wire \_\_\_\_\_
7. From the wiring diagram, identify where the headlight is grounded.  
Place of ground \_\_\_\_\_

---

Task Completed

8. Connect the negative lead of the meter to the point where the headlight is grounded.

9. Connect the positive lead of the meter to the power input of the headlight.

10. Turn on the headlights.

What is your reading on the meter? \_\_\_\_\_ volts

What is being measured? \_\_\_\_\_

11. What is the difference between the reading here and the battery's voltage?

\_\_\_\_\_ volts

12. Explain why there is a difference. \_\_\_\_\_

---

---

---

---

---

Instructor's Response \_\_\_\_\_

---

---

Name \_\_\_\_\_ Date \_\_\_\_\_

## USE OF AN OHMMETER

Upon completion of this job sheet, you should be able to check continuity of a circuit and measure resistance on a variety of components.

### ASE Correlation

This job sheet is related to the ASE Electrical/Electronic System Certificate Exam's content area: *General Electrical/Electronic System Diagnosis*; task: check continuity and resistances in electrical/electronic circuits and components with an ohmmeter; determine needed repairs.

### Tools and Materials

- A vehicle
- An analog ohmmeter
- A DMM
- Wiring diagram for the vehicle

**NOTE:** An ohmmeter works by sending a small amount of current through the path to be measured. Because of this, all circuits and components being tested must be disconnected from power. An ohmmeter must never be connected to an energized circuit; doing so may damage the meter. The safest way to measure ohms is to disconnect the negative battery cable before taking resistance readings.

### Describe the vehicle being worked on.

Year \_\_\_\_\_ Make \_\_\_\_\_ Model \_\_\_\_\_

VIN \_\_\_\_\_ Engine type and size \_\_\_\_\_

### Procedure

Task Completed

1. Locate the fuse panel or power distribution box.
2. With no power to the fuses, check the resistance of each fuse. Summarize your findings:  
 \_\_\_\_\_  
 \_\_\_\_\_  
 \_\_\_\_\_
3. Now connect the leads of the analog meter across the negative battery cable.  
 Your reading is: \_\_\_\_\_ ohms  
 Now connect the leads of the digital meter across the negative battery cable.  
 Your reading is: \_\_\_\_\_ ohms
4. Disconnect the primary wires leading to the ignition coil.  
 Now connect the leads of the analog meter across the terminals of the coil.  
 Your reading is: \_\_\_\_\_ ohms  
 Now connect the leads of the digital meter across the terminals of the coil.  
 Your reading is: \_\_\_\_\_ ohms

5. Reconnect the wires to the coil.  
Carefully remove one spark plug wire from the spark plug and ignition coil distributor cap.  
Now connect the leads of the analog meter across the wire.  
Your reading is: \_\_\_\_\_ ohms  
Now connect the leads of the digital meter across the wire.  
Your reading is: \_\_\_\_\_ ohms
6. Carefully reinstall the spark plug wire.  
Locate the cigar lighter inside the vehicle.  
Now connect the leads of the analog meter from the heating coil to its case.  
Your reading is: \_\_\_\_\_ ohms  
Now connect the leads of the digital meter from the heating coil to its case.  
Your reading is: \_\_\_\_\_ ohms
7. Refer to the service manual and find out how to remove the bulb in the dome light.  
Remove it.  
Now connect the leads of the analog meter across the bulb.  
Your reading is: \_\_\_\_\_ ohms  
Now connect the leads of the digital meter across the bulb.  
Your reading is: \_\_\_\_\_ ohms
8. Reinstall the bulb.  
Remove the rear brake light bulb.  
Now connect the leads of the analog meter across the bulb.  
Your reading is: \_\_\_\_\_ ohms  
Now connect the leads of the digital meter across the bulb.  
Your reading is: \_\_\_\_\_ ohms
9. Reinstall the bulb.  
Disconnect the wire connector to one of the headlights.  
From the wiring diagram, identify which terminals are for low-beam operation.  
Now connect the leads of the analog meter across the low-beam terminals.  
Your reading is: \_\_\_\_\_ ohms  
Now connect the leads of the digital meter across the low-beam terminals.  
Your reading is: \_\_\_\_\_ ohms
10. From the wiring diagram, identify which terminals are for high-beam operation.  
Now connect the leads of the analog meter across the high-beam terminals.  
Your reading is: \_\_\_\_\_ ohms  
Now connect the leads of the digital meter across the high-beam terminals.  
Your reading is: \_\_\_\_\_ ohms
11. You should have gotten slightly different readings from the digital meter and the analog meter. Explain why:  
  
\_\_\_\_\_  
  
\_\_\_\_\_  
  
\_\_\_\_\_  
  
\_\_\_\_\_



12. You measured the resistance across several different light bulbs. On each you should have read a different amount of resistance. Based on your findings, which light bulb would be the brightest and which would be the dimmest? Explain why.

---

---

---

Instructor's Response \_\_\_\_\_

---

---

*This page intentionally left blank*

## BASIC ELECTRICAL TROUBLESHOOTING AND SERVICE



### BASIC TOOLS

Basic mechanic's tool set  
Service information

### UPON COMPLETION AND REVIEW OF THIS CHAPTER, YOU SHOULD BE ABLE TO:

- Describe how different electrical problems cause changes in an electrical circuit.
- Diagnose and repair circuit protection devices.
- Test switches with a variety of test instruments.
- Test relays and relay circuits for proper operation.
- Identify and test fixed and variable resistors with a voltmeter, ohmmeter, or lab scope.
- Diagnose diodes for opens, shorts, and other defects.
- Diagnose transistors for opens, shorts, and other defects.
- Locate and repair opens in a circuit.
- Locate and repair shorts in a circuit.
- Locate and repair the cause of unwanted high resistance in a circuit.
- Set up a digital storage oscilloscope (DSO) and identify wave form.

### INTRODUCTION

Troubleshooting electrical problems involves the same tools and methods, regardless of which **circuit** has the problem. All electrical circuits must have voltage, current, and resistance. Testing for the presence of these, measuring them, and comparing your measurements to specifications is the key to effective diagnosis. To do this, you must have a solid understanding of these basic electrical properties.

Voltage is the electrical pressure that causes electrons to move provided there is a complete path for them to do so. Current is the aggregate flow of electrons through a wire and can be defined as the rate of electron flow. Resistance is defined as opposition to current flow. An electrical circuit must have resistance in it in order to change electrical energy to light, heat, or movement.

An electrical circuit may develop an open, a short, or an excessive voltage drop that will cause it to operate improperly. An **open circuit** is a circuit in which there is a break in continuity. The open can be on either the insulated side or the ground side. A **shorted circuit** decreases the resistance of the circuit. This happens by shorting across to another circuit or by shorting to a ground. When there is a circuit-to-circuit short, one of the circuits is not controlled by its switch. Since the shorted circuit becomes a new parallel leg to the circuit, the entire parallel circuit will turn on and off with the switch controlling the other circuit. With this type of problem, many strange things can happen. When a circuit is shorted to ground, a new parallel leg is present. This new leg has very low resistance and causes the current in the circuit to increase drastically.

High-resistance problems can occur anywhere in the circuit. However, the effect of high resistance is the same regardless of where it is. Additional or unwanted resistance in series with a circuit will always reduce the current in the circuit and will reduce the amount of voltage drop by the component in the circuit.

The term **circuit** means a circle and is the path of electron flow consisting of the voltage source, conductors, load component, and return path to the voltage source.



**SPECIAL TOOLS**

- Voltmeter
- Test light
- Self-powered test light
- Ohmmeter
- Jumper wire
- DSO

**TESTING FOR CIRCUIT DEFECTS**

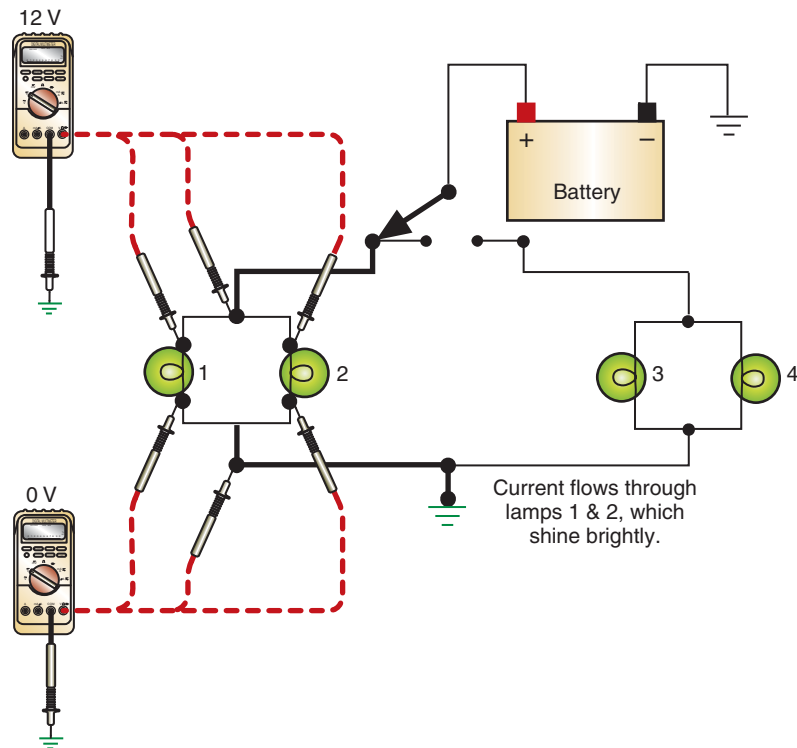
Electrical circuits may develop an open, a short, a ground, or an excessive voltage drop that will cause the circuit to operate improperly.

**Testing for Opens**

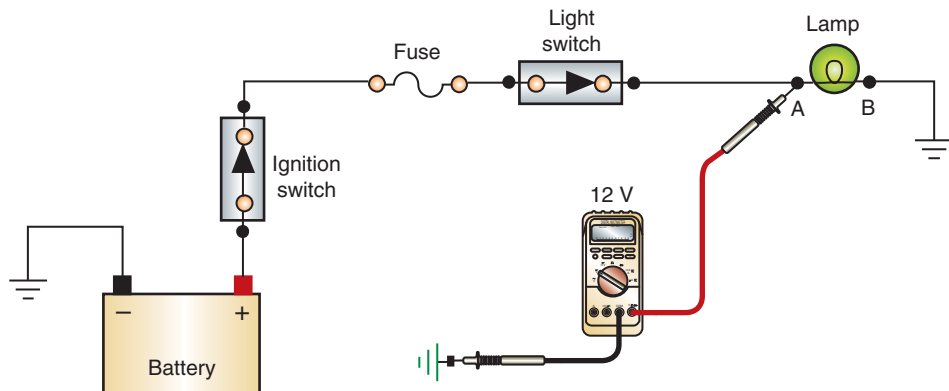
It is possible to test for opens using a voltmeter, DSO, test light, self-powered test light, ohmmeter, or a jumper wire. The test equipment used will depend on the circuit being tested and the accessibility of the components.

The technician must determine the correct operation of the circuit before attempting to determine what is wrong. The illustration (Figure 3-1) shows the voltmeter readings that should be obtained in a properly operating parallel circuit.

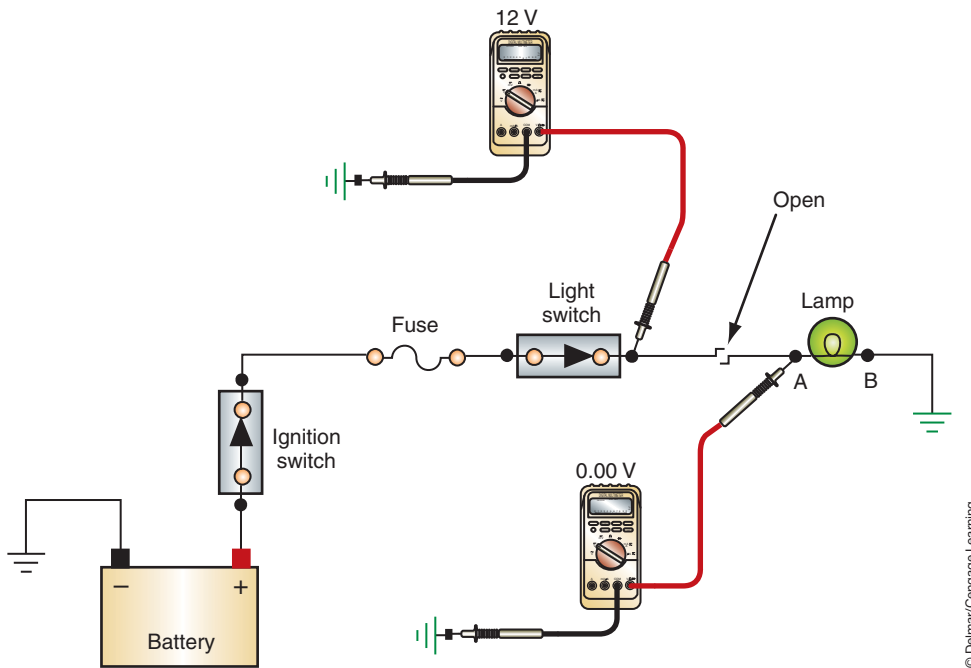
The easiest method of testing a circuit is to start at the most accessible place and work from there. If the load component is easily accessible, test for voltage at the input to the load (Figure 3-2). Use the following procedure for locating the open:



**FIGURE 3-1** Voltmeter readings that would be expected in a properly operating parallel circuit.



**FIGURE 3-2** Locating an open by testing for voltage.



**FIGURE 3-3** An open is present between the point where voltage was measured and where it was not.

© Delmar/Cengage Learning

1. Check for voltage at point A. If voltage is 10.5 volts or higher, check the ground side (point B). If less than 10.5 volt is present, there is excessive resistance or an open in the ground circuit. If the voltage at point A is less than 10.5 volts, continue testing.
2. Work toward the battery. Test all connections for voltage. If voltage is present at a connection, then the open is between that connection and the previously tested location (Figure 3-3). Use a jumper wire to bypass that section to confirm the location of the open.
3. If battery voltage is present at point B, the open is in the ground circuit. Use a jumper wire to connect the ground circuit. Then retest the component.

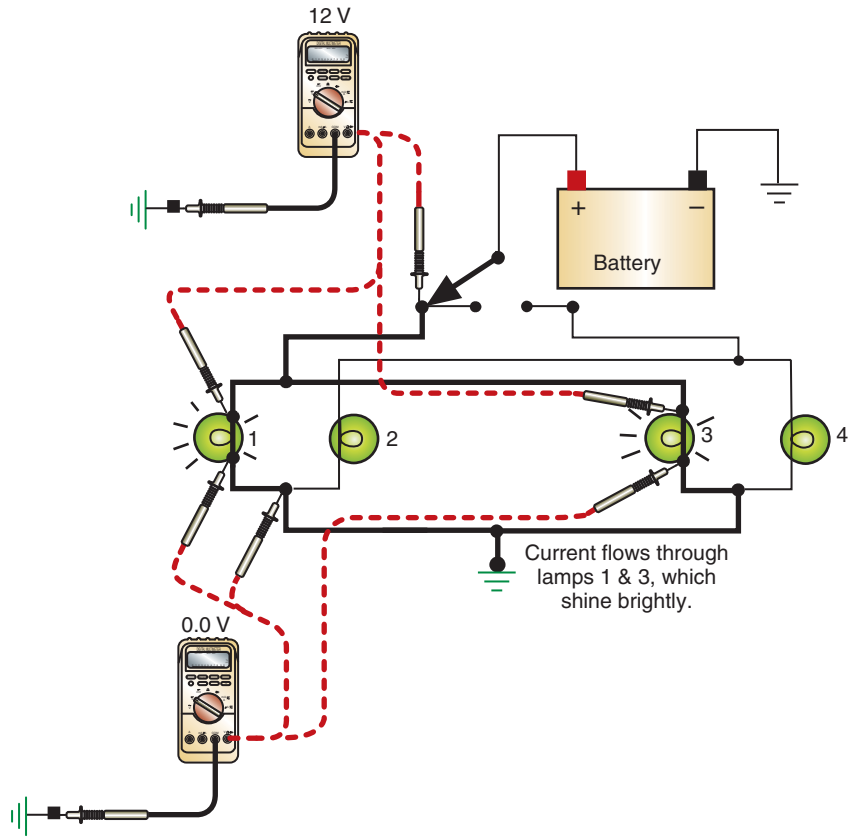
An open circuit will not blow a fuse.

In more complex circuits, the open may have very different results. In a normally operating circuit, the voltmeter readings would be as indicated in the illustration (Figure 3-4). If an open occurs in the ground side of the circuit, the circuit converts to a series circuit (Figure 3-5). This type of circuit defect is a form of **feedback** that results in lamps coming on that are not intended to. If the electrons cannot find a path to ground through the intended circuit, they will attempt to find an alternate path to ground. This may result in turning on components that are in the path. Normal voltage is applied to lamp 3, but lamps 1, 2, and 4 are in series and will illuminate dimmer than normal. The voltmeter will read 12 volts at the locations illustrated in Figure 3-5. However, the voltmeter will not indicate 0 volts on the ground side of bulb 1.

## Testing for Shorts

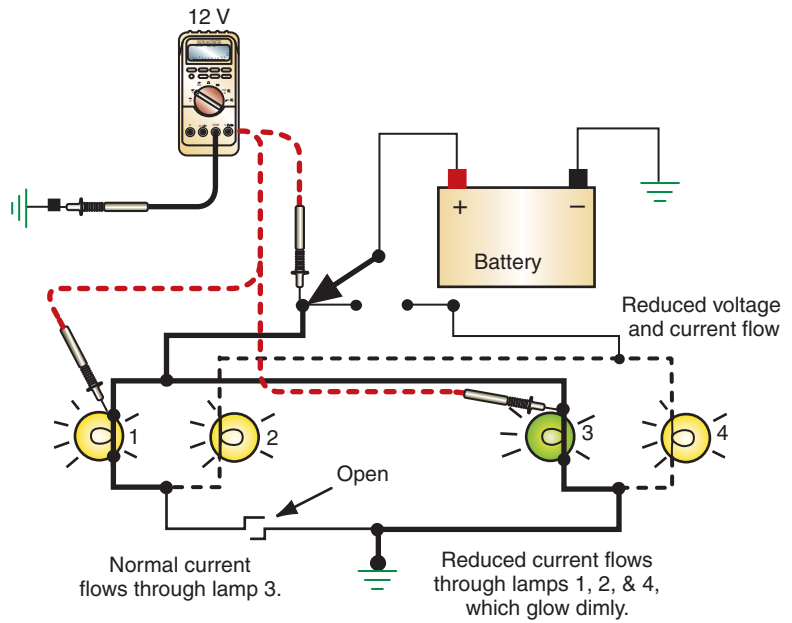
Locating a copper-to-copper short can be one of the most difficult tasks for a technician. If the short is within a component, the component will operate at less than optimum or not at all. An ohmmeter can be used to check the resistance of the component. If there is a short, then the amount of resistance will be lower than specified. If specifications for the component are not available, it may be necessary to replace the component with a known good unit. Do this only after it has been determined that the insulated and ground side circuits are in good condition.

**Classroom Manual**  
Chapter 3, page 75



**FIGURE 3-4** Properly operating complex parallel circuit.

© Delmar/Cengage Learning



**FIGURE 3-5** An open in the ground circuit can convert the circuit to a series circuit. The dashed line represents the resulting path to ground.

© Delmar/Cengage Learning



If the short is between circuits, the result will be components operating when not intended (Figure 3-6). Visually check the wiring for signs of burned insulation and melted conductors that will indicate a short. Also check common connectors that are shared by the two affected circuits. Corrosion can form between two terminals of the connector and result in the short.

If the visual inspection does not isolate the cause of the copper-to-copper short, remove one of the fuses for the affected circuits. (If the affected circuits share a common fuse, remove it.) Install a buzzer that has been fitted with terminals across the fuse holder terminals (Figure 3-7). Activate the circuit that the buzzer is connected to. In Figure 3-6, if the buzzer is connected to fuse B, then switch 1 would be turned on. Disconnect the loads that are supposed to be activated by this switch (lamp 1). Disconnect the wire connectors in the circuit from the load back to the switch. If the buzzer stops when a connector is disconnected, the short is in that portion of the circuit.



### SPECIAL TOOLS

Ohmmeter  
Buzzer fitted with terminals and in-line fuse

A short may not blow a fuse depending on the amount of current flowing.

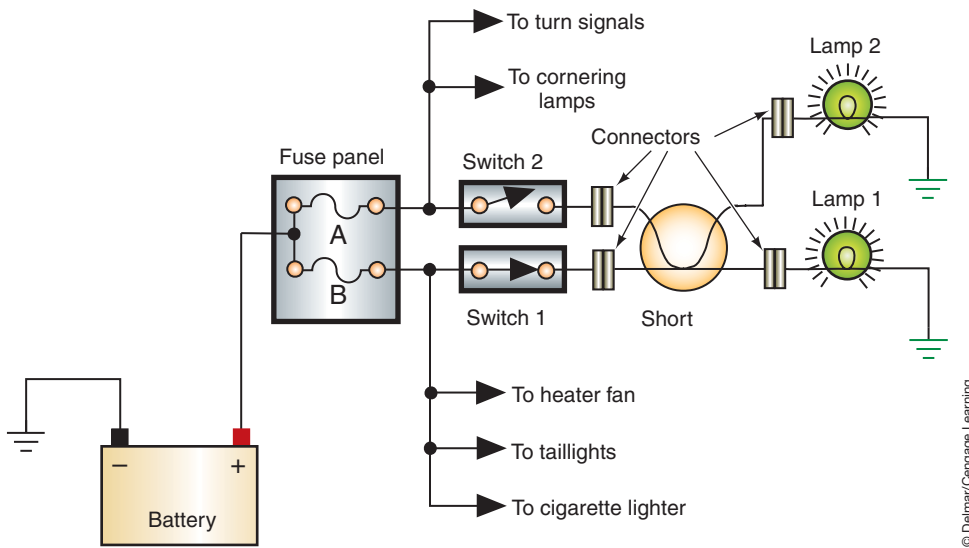


FIGURE 3-6 A copper-to-copper short between two circuits.

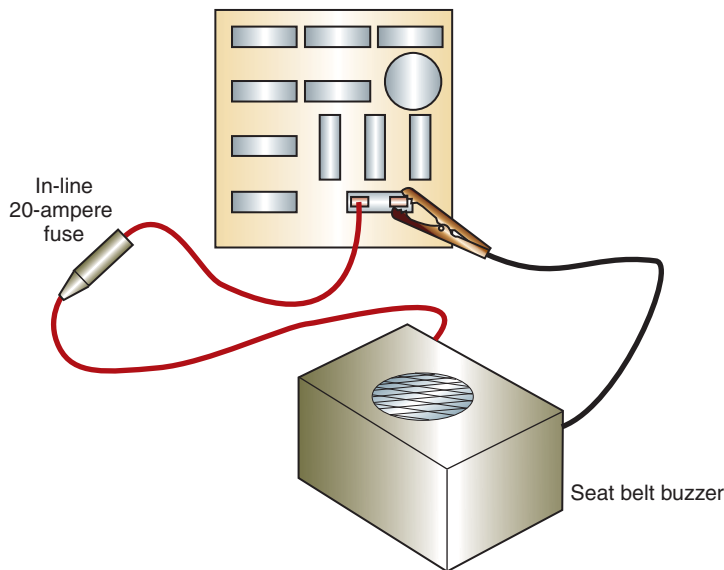


FIGURE 3-7 The buzzer will sound until the cause of the short is found and corrected.



**SPECIAL TOOLS**

- Test light
- Circuit breaker fitted with terminals
- Gauss gauge or compass
- Ohmmeter

A buzzer can be substituted for the test light.



**CAUTION:**

Use a circuit breaker that is rated between 25 and 30 amperes. The use of a circuit breaker rated too high will damage the circuit.

## Testing for a Short to Ground

A fuse that blows as soon as it is installed indicates a **short to ground**. This condition allows current to return to ground before it has reached the intended load component. If the circuit is unfused, the insulation and conductor will melt. Not all shorts will blow the fuse, however. If the short to ground is on the ground side of the load component but before a grounding switch, the component will not turn off (Figure 3-8). If the short to ground is after the load and grounding switch (if applicable), circuit operation will not be affected.

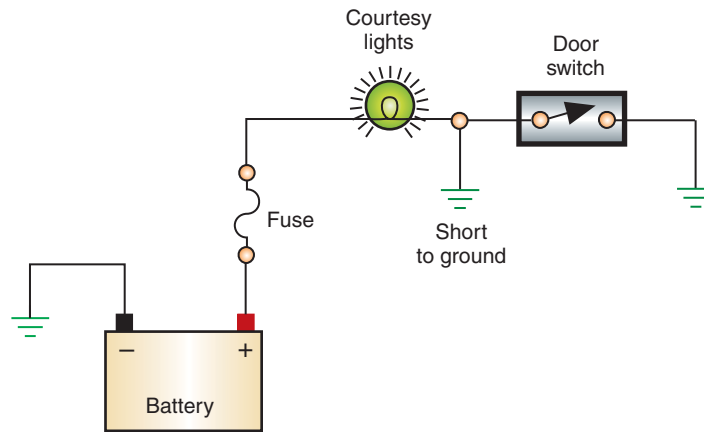
To confirm that the circuit has a ground before the load, remove the fuse and connect a test light in series across the fuse connections. If the lamp lights, the circuit has a short to ground.

It is difficult to test for shorts to ground with a test light or voltmeter because the fuse blows before any testing can be conducted. To prevent this, connect a cycling circuit breaker that is fitted with alligator clips across the fuse holder (Figure 3-9). The circuit breaker will continue to cycle open and closed, allowing the technician to test for voltage.

Testing for shorts may be complicated if there are several circuits protected by a single fuse and if the ground is located in a section of wire that is not accessible. There are a couple of methods that can be used to locate the fault.

One method is to connect a test light, in series with a cycling circuit breaker, across the fuse holder (Figure 3-10). While observing the test light, disconnect individual circuits one at a time until the light goes out. The fault is in the circuit that was disconnected when the light went off.

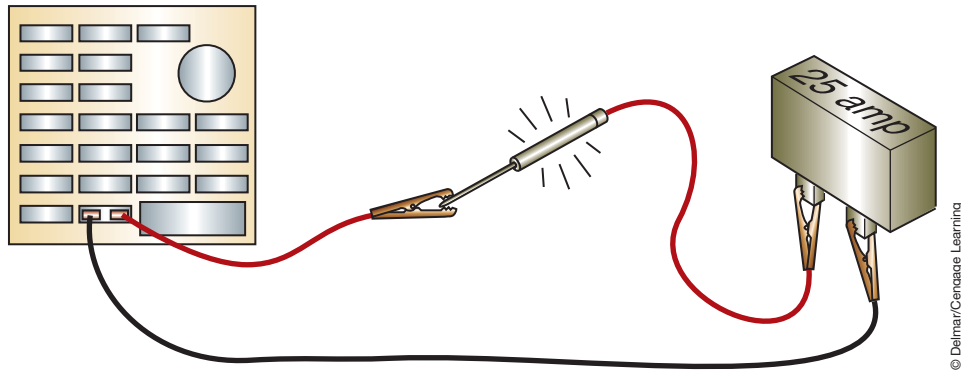
A second method is to use a **Gauss gauge** or a compass to locate the short to ground. A Gauss gauge is a meter that is sensitive to the magnetic field surrounding a wire conducting current. The gauge or compass works on the principle that a magnetic field is developed around a conductor that is carrying current. With a cycling circuit breaker bypassing the



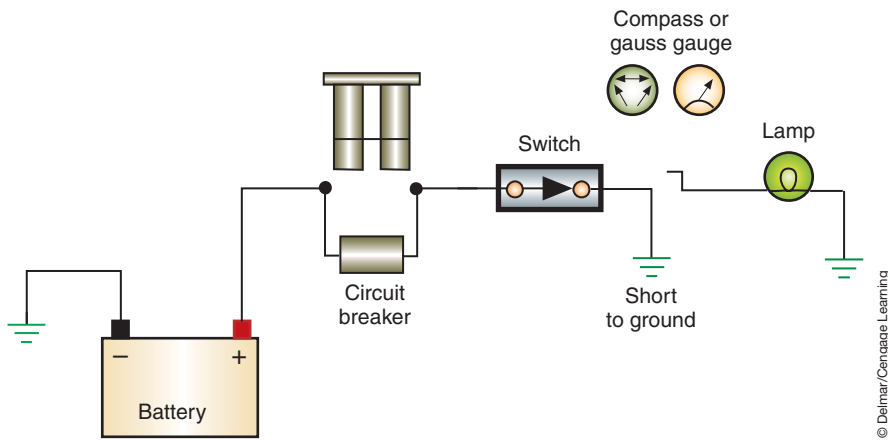
**FIGURE 3-8** A ground in this location will cause the lamp to remain on.



**FIGURE 3-9** Use a circuit breaker to protect the circuit while checking for the short to ground.



**FIGURE 3-10** The test light will allow the technician to “see” when they have located the faulty circuit.



**FIGURE 3-11** The needle of a compass or gauss gauge will fluctuate over the portion of the circuit that has current flowing through it. Once the short to ground has been passed, the needle will stop fluctuating.

blown fuse, trace the path of the circuit with the gauge or compass. The needle will fluctuate as long as the gauge is over the conductor. The needle will stop fluctuating when the point of the short to ground is passed (Figure 3-11). This method will work even through the vehicle’s trim. It will be necessary to follow all of the circuits protected by the fuse. Consult the wiring diagram for this information.

## Testing for Voltage Drop

Voltage drop, when considered as a defect, defines the portion of applied voltage that is used up in other points of the circuit rather than that used by the load component. It is a resistance in the circuit that reduces the amount of electrical pressure available beyond the resistance. Excessive voltage drop may appear on either the insulated or ground return side of a circuit. To test for voltage drop, the circuit must be active (current flowing). The source voltage must be as specified before voltage drop readings can be valid. Whenever voltage drop is suspected, both sides of the circuit must be checked.

Excessive voltage drop caused by high resistance can be identified by dim or flickering lamps, inoperative load components, or slower-than-normal electrical motor speeds. Excessive resistance will not cause the fuse to blow.

To perform a voltage drop test on any circuit, the positive voltmeter lead must be connected to the most positive portion of the circuit. Follow the instructions shown in Photo Sequences 4 to conduct a voltage drop test. Consult the service information for the maximum amount of voltage drop allowed. When the voltage drop decreases to within specifications, the cause of the excessive resistance has been located. In Photo Sequence 4, a faulty relay was the cause of the excessive resistance.

**Classroom  
Manual**

Chapter 3, page 77



**SPECIAL TOOLS**

Voltmeter

## PHOTO SEQUENCE 4

### VOLTAGE DROP TEST TO LOCATE HIGH CIRCUIT RESISTANCE

All photos in this sequence are © Delmar/Cengage Learning.



**P4-1** Tools required to test for excessive resistance in a starting circuit are fender covers, a DVOM, and a remote starter switch.



**P4-2** Connect the positive lead of the meter to the positive battery post. If possible, do not connect the lead to the cable clamp.



**P4-3** Connect the negative lead of the meter to the main battery terminal on the starter motor.



**P4-4** To conduct a voltage drop test, current must flow through the circuit. In this test, the ignition system is disabled and the engine is cranked using a remote starter switch.



**P4-5** With the engine cranking, read the voltmeter. The reading is the amount of voltage drop.



**P4-6** If the reading is out of specifications, test at the next connection toward the battery. In this instance, the next test point is the starter side of the relay.



**P4-7** Crank the engine and touch the negative test lead to the starter side of the relay. Observe the voltmeter while the engine is cranking.

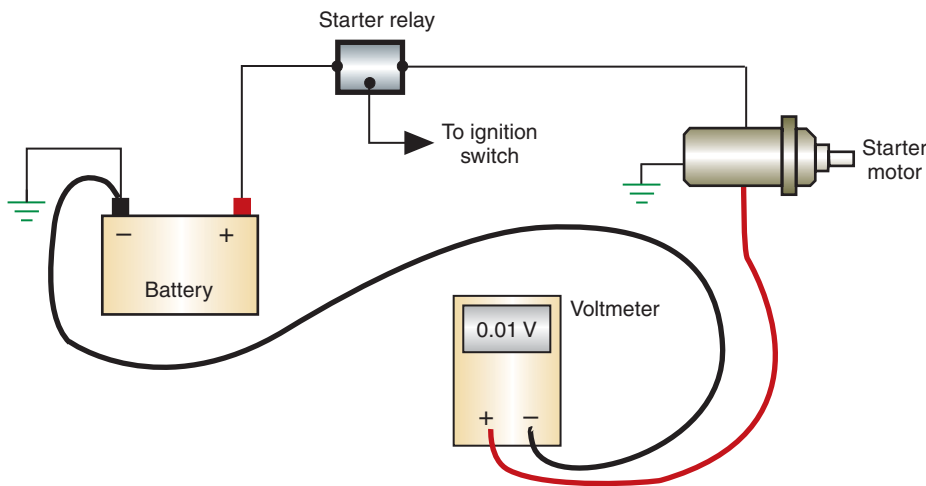


**P4-8** Test in the same manner on the battery side of the relay. This is the voltage drop across the positive circuit from the battery to the relay.

When testing the ground side of the circuit, the ground connection terminal of the load component is the most positive location and the battery negative post is the most negative (Figure 3-12). Usually more than 0.1 volt indicates excessive resistance in the ground circuit.

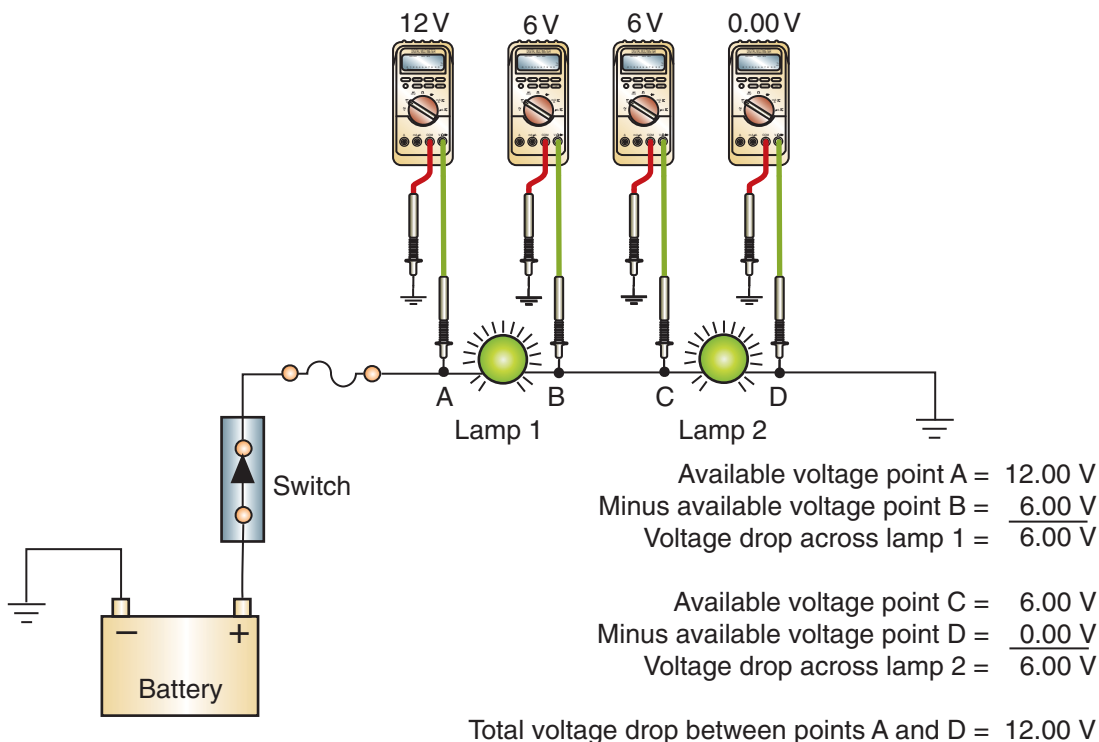
According to many manuals, the maximum allowable voltage drop for an entire circuit, except for the drop across the load, is 10% of the source voltage. Although 1.2 volts is the maximum acceptable amount, it is still too much. Many good technicians use 0.5 volts as the maximum allowable drop. However, there should be no more than 0.1 volts dropped across any one wire or connector. This is the most important specification to consider and remember.

It is possible to calculate voltage drop by testing for available voltage. Use Ohm's law to determine the correct amount of voltage drop that should be across a component. Test for available voltage on both sides of the load component (Figure 3-13). Subtract the available voltage readings to obtain the amount of voltage drop across the component.



© Delmar/Cengage Learning

**FIGURE 3-12** Testing the ground side of the starter motor circuit for high resistance by measuring voltage drop. Notice the voltmeter connections.



© Delmar/Cengage Learning

**FIGURE 3-13** Using available voltage to calculate voltage drop over a component. This method is used if the wires of the circuit are too long to test with standard test leads.





### SPECIAL TOOLS

Ohmmeter  
Voltmeter  
Test light



### CAUTION:

Fuses and other protection devices do not wear out. They fail because something went wrong. Never replace a fuse or fusible link, or reset a circuit breaker, without finding out why it failed.

A blade type fuse is called a spade fuse.

A fuse link is commonly called a **fusible link**.



### CAUTION:

Always disconnect the battery ground cable prior to servicing any fuse link.

## TESTING CIRCUIT PROTECTION DEVICES

A protection device is designed to “turn off” the system whenever excessive current or an **overload** occurs. There are three basic types of **fuses** in automotive use: cartridge, blade, and ceramic. A fuse is a replaceable element that will melt should the current passing through it exceed the fuse rating. The cartridge fuse is found on most older domestic cars and a few imports. To check this type of fuse, look for a break in the internal metal strip. Discoloration of the glass cover or glue bubbling around the metal caps is an indication of overheating. Late-model domestic vehicles and many imports use blade or spade fuses. To check the fuse, pull it from the fuse panel and look at the fuse element through the transparent plastic housing. Look for internal breaks and discoloration. The ceramic fuse is used on many older European imports. To check this type of fuse, look for a break in the contact strip on the outside of the fuse. All types of fuses can be checked with an ohmmeter or test light. If the fuse is good, there will be continuity through it.

Fuses are rated by the current at which they are designed to blow. A three-letter code is used to indicate the type and size of fuses. Blade fuses have codes ATC or ATO. All glass SFE fuses have the same diameter, but the length varies with the current rating. Ceramic fuses are available in two sizes, code GBF (small) and the more common code GBC (large). The amperage rating is also embossed on the insulator. Codes such as AGA, AGW, and AGC indicate the length and diameter of the fuse. Fuse lengths in each of these series is the same, but the current rating can vary. The code and the current rating are usually stamped on the end cap.

The current rating for blade fuses is indicated by the color of the plastic case (Table 3-1). In addition, it is usually marked on the top. The insulator on ceramic fuses is color coded to indicate different current ratings.

Fuses are located in a box or panel, usually under the dashboard, behind a panel in the foot well, or in the engine compartment. Fuses are generally numbered, and the main components abbreviated. On late-model cars there may be icons or symbols indicating which circuits they serve. This identification system is covered in more detail in the owner’s and service informations.

A fusible link is a conductor with a special heat-resistant insulation. When there is an overload in the circuit, the link melts and opens the circuit. Fusible links are used in circuits where limiting the maximum current is not extremely critical. They are often installed in the positive battery lead to the ignition switch and other circuits that have power with the key off.

A **fusible link** is a short length of small-gauge wire installed in a conductor. Since the fusible link is a lighter gauge of wire than the main conductor, it melts and opens the circuit before damage can occur in the rest of the circuit. Fusible link wire is covered with a special insulation that bubbles when it overheats, indicating that the link has melted. If the insulation appears good, pull lightly on the wire. If the link stretches, the wire has melted. Of course, when it is hard to determine if the fusible link is burned out, check for continuity through the link with a test light or ohmmeter.

To replace a fusible link, cut the protected wire where it is connected to the fusible link. Then, tightly crimp or solder a new fusible link of the same rating as the original link. Since the insulation on the manufacturer’s fusible links is flameproof, never fabricate a fusible link from ordinary wire because the insulation may not be flameproof.

Many late-model vehicles use maxi-fuses instead of fusible links. Maxi-fuses look and operate like two-prong, blade or spade fuses, except they are much larger and can handle more current. (Typically, a maxi-fuse is four to five times larger.) Maxi-fuses are located in a fuse box in the engine compartment and/or passenger compartment, under the dash or the rear seat.

Maxi-fuses are easier to inspect and replace than are fuse links. To check a maxi-fuse, look at the fuse element through the transparent plastic housing. If there is a break in the element, the maxi-fuse has blown. To replace it, pull it from its fuse box or panel. Always replace a blown maxi-fuse with a new one having the same ampere rating.



**TABLE 3-1** Typical color coding of protection devices.

Blade Fuse Color Coding	
Ampere Rating	Housing Color
4	pink
5	tan
10	red
15	light blue
20	yellow
25	natural
30	light green
Fuse Link Color Coding	
Wire Link Size	Insulation Color
20 GA	blue
18 GA	brown or red
16 GA	black or orange
14 GA	green
12 GA	gray
Maxi-fuse Color Coding	
Ampere Rating	Housing Color
20	yellow
30	light green
40	amber
50	red
60	blue



**SERVICE TIP:**

To calculate the correct fuse rating, use Watt's law: watts divided by volts equals amperes. For example, if you are installing a 55-watt pair of fog lights, divide 55 by the battery voltage (12 volts) to find out how much current the circuit has to carry. Since  $55 \div 12 = 4.58$ , the current is approximately 5 amperes. To allow for current surges, the correct in-line fuse should be rated slightly higher than the normal current flow. In this case, an 8- or 10-ampere fuse would do the job.

Some circuits are protected by circuit breakers. Like fuses, they are rated in amperes. There are two types of circuit breakers: cycling or those that must be manually reset.

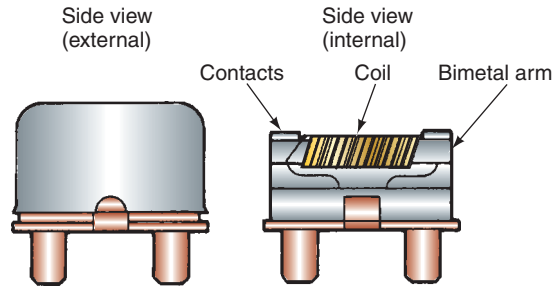
In the cycling type, the bimetal arm will begin to cool once the current to it is stopped. Once it returns to its original shape, the contacts are closed and power is restored. If the current is still too high, the cycle of breaking the circuit will be repeated.

Two types of noncycling or resettable breakers are used. One is reset by removing the power from the circuit. There is a coil wrapped around a bimetal arm (Figure 3-14A). When there is excessive current and the contacts open, a small current passes through the coil. This current through the coil is not enough to operate a load, but it does heat up both the coil and the bimetal arm. This keeps the arm in the open position until power is removed. The other type is reset by depressing a reset button. A spring pushes the bimetal arm down and holds the contacts together (Figure 3-14B). When an overcurrent condition exists and the bimetal arm heats up, the bimetal arm bends enough to overcome the spring and the contacts snap open. The contacts stay open until the reset button is pushed, which snaps the contacts together again.

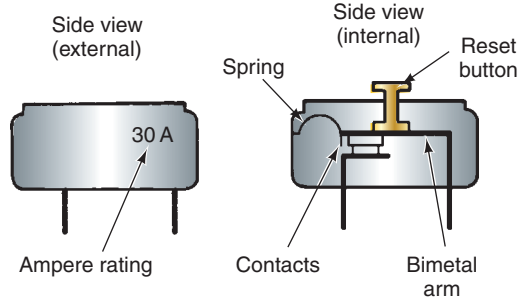
A visual inspection of a fuse or fusible link will not always determine if it has an open (Figure 3-15). To accurately test a circuit protection device, use an ohmmeter, voltmeter, or test light.

A circuit breaker is typically abbreviated c.b. in a fuse chart of a service information.

**Non-cycling circuit breaker that is reset by removing from power.**

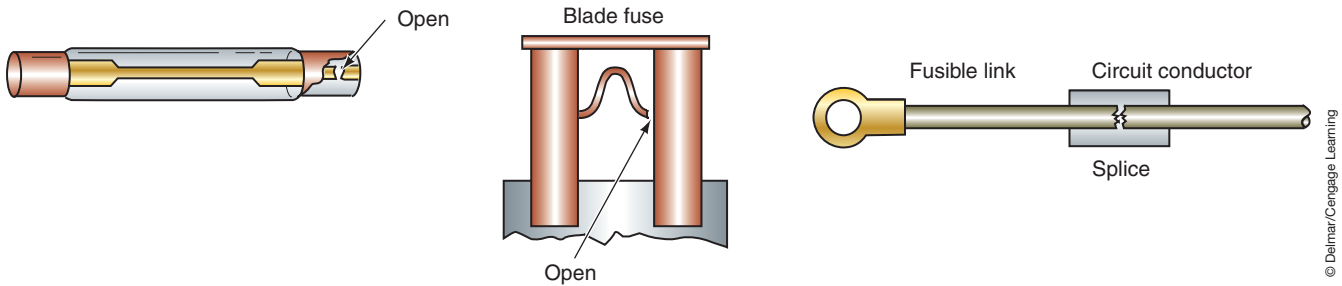


**Manual resetting circuit breaker.**



© Delmar/Cengage Learning

**FIGURE 3-14** The two basic types of circuit breakers.



© Delmar/Cengage Learning

**FIGURE 3-15** A fuse or fusible link can have a hidden fault that cannot be seen by the technician.



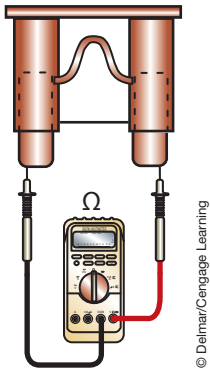
**SERVICE TIP:**

Before using a test light, it is good practice to check the tester's lamp. To do this, simply connect the test light across the battery. The light should come on.

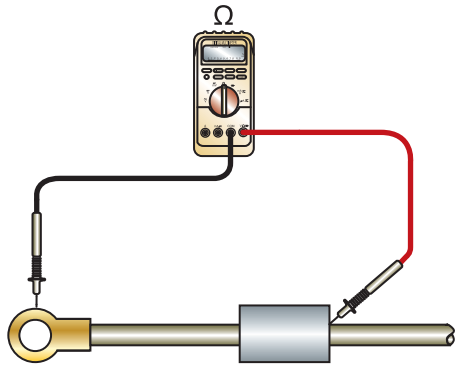
With the fuse or circuit breaker removed from the vehicle, connect the ohmmeter's test leads across the protection device's terminals (Figure 3-16). On its lowest scale, the ohmmeter should read 0 to 1 ohms. If it reads infinite, the protection device is open. Test a fusible link in the same way (Figure 3-17). Before connecting the ohmmeter across the fusible link, make sure there is no current flow through the circuit. To be safe, disconnect the negative cable of the battery.

To test a circuit protection device with a voltmeter, check for available voltage at both terminals of the unit (Figure 3-18). If the device is good, voltage will be present on both sides. A test light can be used in place of a voltmeter. The lamp should illuminate when each test terminal is touched with the lamp's probe.

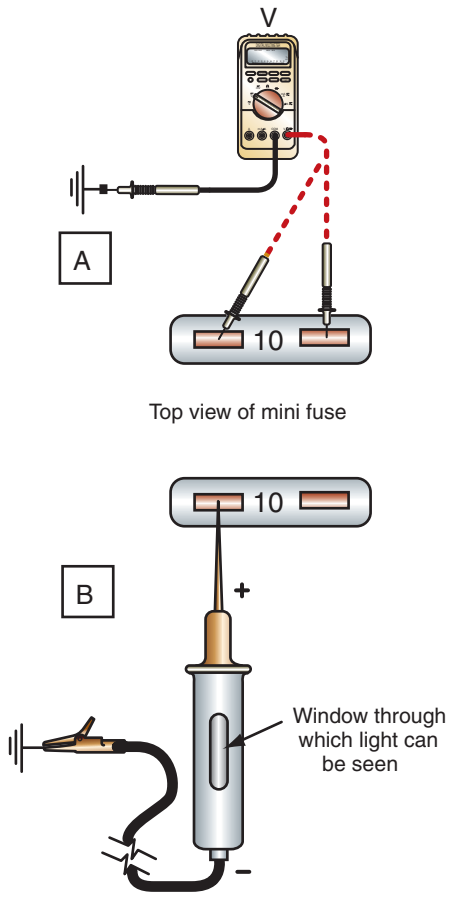
Measuring voltage drop across a fuse or other circuit protection device will tell you more about its condition than whether or not it is open. If a fuse, a fuse link, or circuit breaker is in good condition, a voltage drop of near zero will be measured. If 12 volts is read, the fuse is open. Any reading between zero and 12 volts indicates some voltage drop. If there is voltage drop across the fuse, it has resistance and should be replaced. Make sure you check the fuse holder for resistance as well.



**FIGURE 3-16** A good fuse will have zero resistance when tested with an ohmmeter.



**FIGURE 3-17** A fusible link can be tested with an ohmmeter, once it is disconnected from power.



**FIGURE 3-18** (A) Voltmeter test of a circuit protection device. Battery voltage should be present on both sides. (B) The test light will illuminate on both terminals if the fuse is good.



**CAUTION:**  
Fuses are rated by amperage and voltage. Never install a larger rated fuse into a circuit than the one that was designed by the manufacturer. Doing so may damage or destroy the circuit. Also do not replace a fusible link with a resistor wire or vice versa.



**CAUTION:**  
Do not use an unfused jumper wire to bypass the protection device. Circuit damage may result.

**CUSTOMER CARE:** Any time you install additional electrical accessories for customers, provide them with information concerning the type and size of fuses installed so they can put this information with their owner's manual.



**SPECIAL TOOLS**

- Jumper wires
- Voltmeter
- Test light
- Ohmmeter



**CAUTION:**

Use a jumper wire to bypass nonresistive portions of the circuit. Do not use the jumper wire to bypass the load component. The high current will damage the circuit. The wire size and fuse of the jumper wire must be appropriate for the current in the circuit.

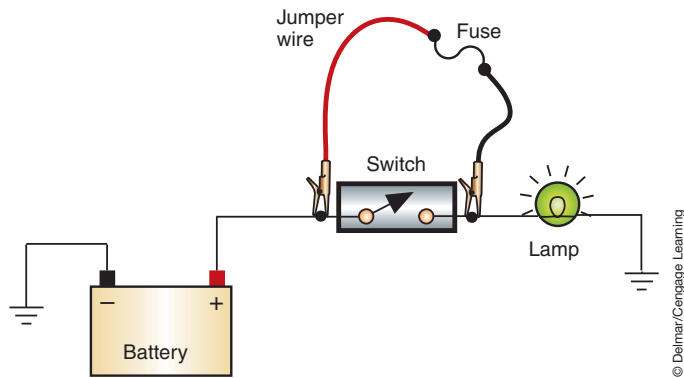
**TESTING AND REPLACING ELECTRICAL COMPONENTS**

All electrical components can fail. Testing them is the best way of determining if they are good or bad. For the most part, the proper way to check electrical components is determined by what the component is supposed to do. If we think about what something is supposed to do and how it does it, we can figure out how to test it. Often, removing the component and testing it on a bench is the best way to check it.

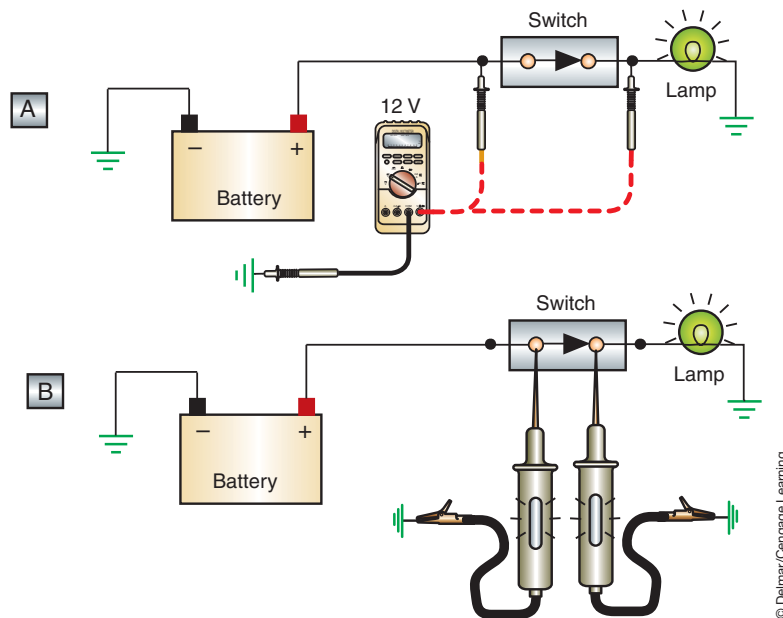
**Switches**

The easiest method of testing a **normally open (NO)** switch is to use a fused jumper wire to bypass the switch (Figure 3-19). An NO switch will not allow current flow when it is in its rest position. The contacts are open until they are acted on by an outside force that closes to complete the circuit. If the circuit operates with the switch bypassed, the switch is defective. Voltage drop across switches should also be checked. Ideally, when the switch is closed, there should be no voltage drop. Any voltage drop indicates resistance, and the switch should be replaced.

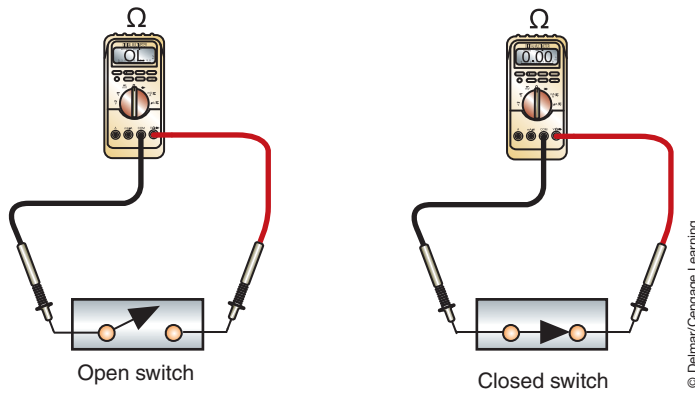
A voltmeter or test light can be used to check for voltage on both sides of the switch (Figure 3-20). A faulty NO switch would have voltage present at the input side of the switch but not on the output side when in the ON position.



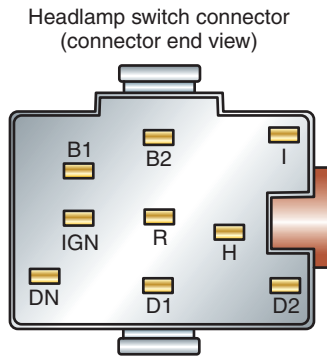
**FIGURE 3-19** Using a fused jumper wire to bypass the switch.



**FIGURE 3-20** (A) Using a voltmeter to test a switch, the same voltage should be on both sides of the switch. (B) Using a test lamp to test a switch, the lamp should illuminate on both sides of the switch.



**FIGURE 3-21** The continuity through a switch can be checked with an ohmmeter. With the switch open, there should be infinite resistance. With the switch closed, there should be zero resistance.



Pin number	Circuit	Circuit function
B1	38 (BK/O)	Power supply to battery
B2	195 (T/W)	Tail lamp switch feed
I	19 (LB/R)	Instrument panel lamp feed
IGN		Not used
R	14 (BR)	Tail lamp and side marker lamps
H	15 (R/Y)	Headlamp dimmer switch feed
DN		Not used
D1	54 (LG/Y)	Interior lamp switch feed
D2	706 (GY)	Battery saver door switch feed

**FIGURE 3-22** Example of headlight switch connector callouts that are used for continuity checks.

If the switch is removed, it can be tested with an ohmmeter. With the switch contacts open, there should be no continuity between the terminals (Figure 3-21). When the contacts are closed, there should be zero resistance through the switch contacts. On complex ganged-type switches, the technician should consult the service information for a continuity diagram (Figure 3-22). If there is no continuity chart, use the wiring diagram to make your own chart.

## Relays

A **relay** is a device that uses low current to control a high-current circuit. The relay can be either a normally open or normally closed design. The relay can be checked using a jumper wire, voltmeter, ohmmeter, or test light. If the terminals are easily accessible, the jumper wire and test light may be the fastest method.



## SPECIAL TOOLS

Jumper wires  
Test light  
Voltmeter  
Ohmmeter

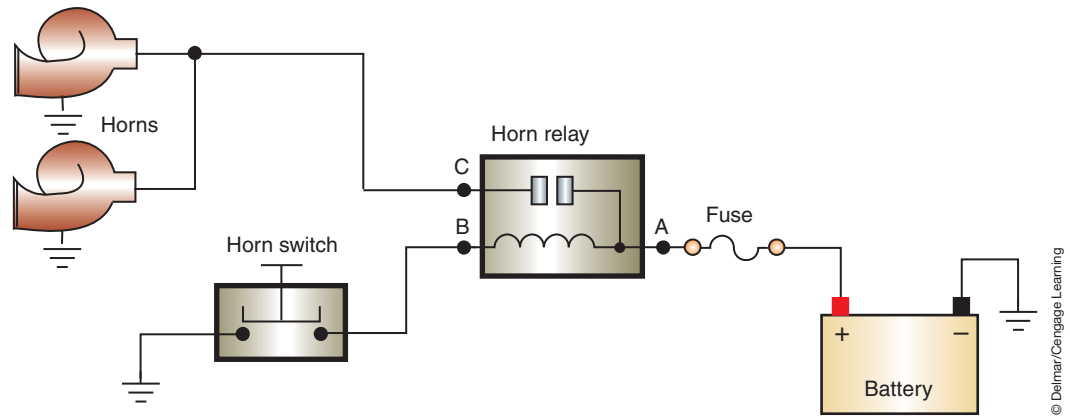


FIGURE 3-23 A relay circuit with a ground control switch.

Check the wiring diagram for the relay being tested to determine if the control is through an insulated or ground switch. Use the illustration (Figure 3-23) as a guide to test a ground-switch-controlled relay. Follow these steps:

1. Use a voltmeter to check for available voltage to the battery side of the relay (terminal A). If voltage is not present at this point, the fault is in the circuit from the battery to the relay. If voltage is present, continue testing.
2. Probe for voltage at control terminal B. If voltage is not present at this terminal, then the fault is in the relay coil. If voltage is present, continue testing.
3. Use a jumper wire to connect terminal B to a good ground. If the horn sounds, the fault is in the control circuit from terminal B to the horn switch ground. If the horn does not sound, continue testing.
4. Connect the jumper wire from the battery positive to terminal C. If the horn did not sound, there is a fault in the circuit from the relay to the horn ground. If the horn sounded, the fault is in the relay.

If the relay is controlled by the computer, it is not recommended that a test light be used. The test light may draw more current than the circuit is designed to carry and damage the computer. Refer to the illustration (Figure 3-24) for procedures using a voltmeter to test a relay. Use a DMM set as follows:

1. Connect the negative voltmeter test lead to a good ground.
2. Connect the positive voltmeter test lead to the output wire (terminal B). Turn on the ignition switch. If no voltage is present at this terminal, go to step 3. If the voltmeter reads 10.5 volts or higher, turn off the control circuit. The voltmeter should then read 0 volts. If it does, then the relay is good. If the voltmeter still reads any voltage, the relay is not opening and needs to be replaced.
3. Connect the positive voltmeter test lead to the power input terminal (terminal A). The voltmeter should indicate at least 10.5 volts. If below this value, the circuit from the battery to the relay is faulty. If the voltage value is correct, continue testing.
4. Connect the positive voltmeter test lead to the control circuit terminal (terminal C). The voltage should read 10.5 volts or higher. If not, check the circuit from the battery to the relay (including the ignition switch). If the voltage is 10.5 volts or higher, continue testing.
5. Connect the positive voltmeter test lead to the relay ground terminal (terminal D). If more than 1 volt is indicated on the meter, there is a poor ground connection. If the reading is less than 1 volt, replace the relay.

If the relay terminals are not accessible, remove the relay from its holding fixture and bench test it. Use an ohmmeter to test for continuity between the relay coil terminals (Figure 3-25). If the meter indicates an infinite reading, replace the relay. If continuity is indicated, use a

If the circuit being tested is powered through the ignition switch, it must be in the RUN position.

To obtain accurate voltmeter test results, the battery must be fully charged and in good condition.



### CAUTION:

It is not recommended that a test light be used to probe for power in a computer-controlled circuit. The increased draw of the test light may damage the system components.

Be careful not to touch the coil terminals with the ohmmeter test leads while the coil is energized.



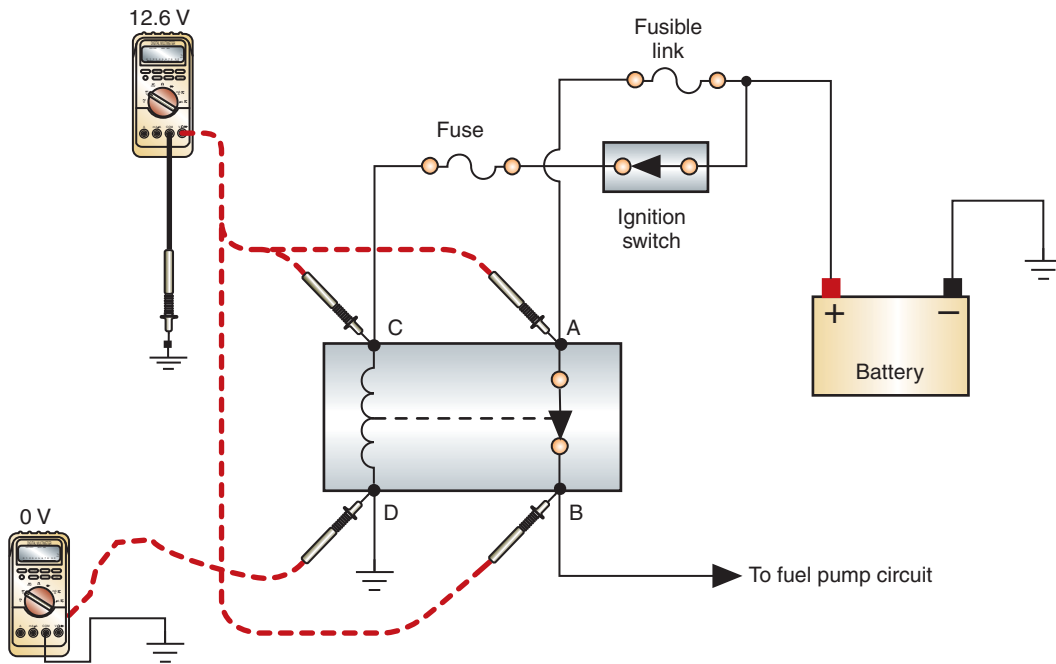


FIGURE 3-24 Testing relay operation with a voltmeter.

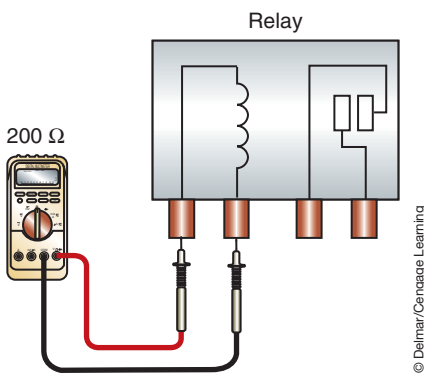


FIGURE 3-25 Testing the resistance of the relay coil.

© Delmar/Cengage Learning

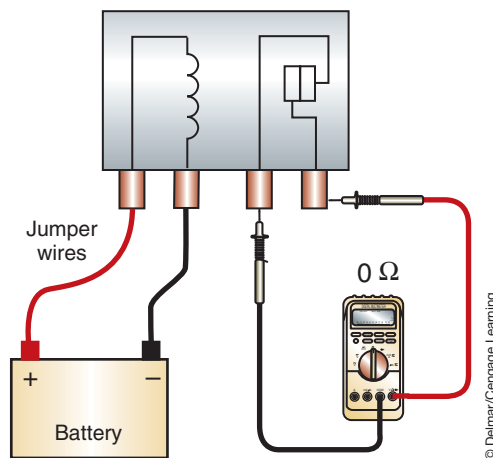


FIGURE 3-26 Bench testing a relay.

© Delmar/Cengage Learning



### SERVICE TIP:

The procedures presented above can be used to test the relay to determine the type of fault it has. However, the easiest way to test a relay is to substitute it with a *known good* relay of the same type. If the circuit operates with the substitute relay, the old relay is the faulty component.

pair of jumper wires to energize the coil (Figure 3-26). Check for continuity through the relay contacts. If the meter indicates an infinite reading, the relay is defective. If there is continuity, the relay is good and the circuits will have to be checked.

Be sure to check your service information for resistance specifications and compare the relay to them. It is easy to check for an open coil. However, a shorted coil will also prevent the relay from working. Low resistance across a coil would indicate that it is shorted. Too low of resistance may also damage the transistors and/or driver circuits because of the excessive current that would result.

## Testing Stepped Resistors

A **stepped resistor** has two or more fixed resistor values (Figure 3-27). The best method of testing a stepped resistor is to use an ohmmeter. To obtain accurate test results, it is a good practice to remove the resistor from the circuit. Connect the ohmmeter leads to the two ends of the resistor (Figure 3-28). Compare the results with manufacturer's specifications. Be sure to place the ohmmeter on the correct scale to read the anticipated amount of resistance.

**Classroom Manual**

Chapter 3, page 58



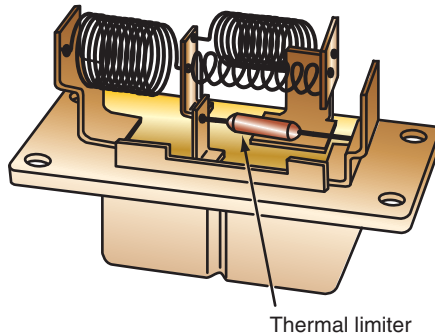
## SPECIAL TOOLS

Ohmmeter  
Voltmeter  
DSO

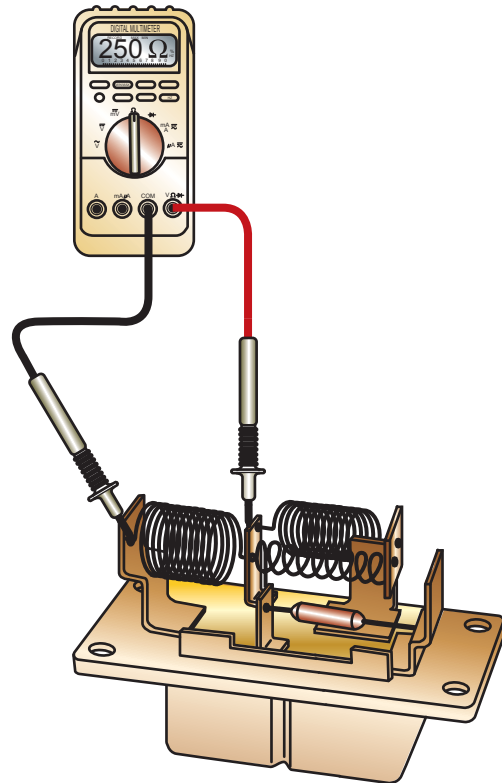


### CAUTION:

Operating a blower motor resistor out of the air flow of the EVAP housing will cause the resistor to overheat and be damaged.



**FIGURE 3-27** A stepped resistor used in the heater blower motor circuit.



**FIGURE 3-28** Ohmmeter testing of a stepped resistor.

A stepped resistor can also be checked with a voltmeter or DSO. By measuring the voltage after each part of the resistor block and comparing the readings to specifications, you can tell if the resistor is good or not.

### Classroom Manual

Chapter 3, page 58

## Testing Variable Resistors

A **variable resistor** provides for an infinite number of resistance values within a range. As with the stepped resistor, the best method of testing a variable resistor is with an ohmmeter. However, it is possible to use a voltmeter, DSO, or test light.

A **rheostat** is a two-terminal variable resistor used to regulate the current in an electrical circuit. To test a rheostat, locate the input and output terminals and connect the test leads to them. Rotate the resistor knob slowly while observing the ohmmeter. The resistance value should remain within the specification limits and change in a smooth and constant manner. If the resistance values are out of limits or the resistance value jumps as the knob is turned, replace the rheostat.

If a voltmeter is used, the readings should be smooth and consistent. A test light should change in brightness as the knob is turned; the rheostat is defective if the light blinks at any point.

A **potentiometer** is a three-wire variable resistor that acts as a voltage divider to produce a continuously variable voltage output signal proportional to a mechanical position. To test a potentiometer, connect the ohmmeter test leads to terminals A and C (Figure 3-29). Check the results with specifications. Next connect the ohmmeter test leads to terminals A and B (Figure 3-30). Check the resistance at the stop and observe the ohmmeter as the wiper is moved to the other stop. The resistance values should be within specification and smooth and constant.

A voltmeter can be used in the same manner. However, jumper wires may need to be used to gain access to the test points (Figure 3-31). Because potentiometers are primarily used in computer-controlled circuits, it is not recommended that a test light be used.



## SPECIAL TOOLS

Ohmmeter  
Voltmeter  
Test light  
DSO



© Delmar/Cengage Learning

**FIGURE 3-29** Using an ohmmeter to test the continuity between terminals A and C of a potentiometer.



© Delmar/Cengage Learning

**FIGURE 3-30** Testing continuity between terminals A and B of a potentiometer while the wiper is being moved.



© Delmar/Cengage Learning

**FIGURE 3-31** It may be necessary to use jumper wires to connect the wire connector to the sensor in order to measure voltage.



**CAUTION:**

Do not pierce the insulation to test the potentiometer. These circuits usually operate on 5 to 9 volts. Piercing the insulation may break some of the wire strands, resulting in a voltage drop that will give errant information to the computer. Even if the conductor is not broken, moisture can enter and cause corrosion.

**TESTING DIODES**

A **diode** is an electrical one-way check valve that will allow current to flow in one direction only. Regardless of the bias of the diode, it should allow current flow in one direction only. To test a diode, use an analog ohmmeter. Connect the meter's leads across the diode (Figure 3-32). Observe the reading on the meter. Then reverse the meter's leads and observe the reading on the meter. The resistance in one direction should be very high or infinite and in the other direction, the resistance should be close to zero. If any other readings are observed, the diode is bad. A diode that has low resistance in both directions is shorted. A diode that has high resistance or an infinite reading in both directions is open.

You may run into problems when checking a diode with a high-impedance digital ohmmeter. Since many diodes won't allow current flow through them unless the voltage is at least 0.6 volts, a digital meter may not be able to forward bias the diode. This will result in readings that indicate the diode is open, when in fact it may not be. Because of this

**Classroom Manual**

Chapter 3, page 60



**SPECIAL TOOLS**

Analog ohmmeter  
DVOM

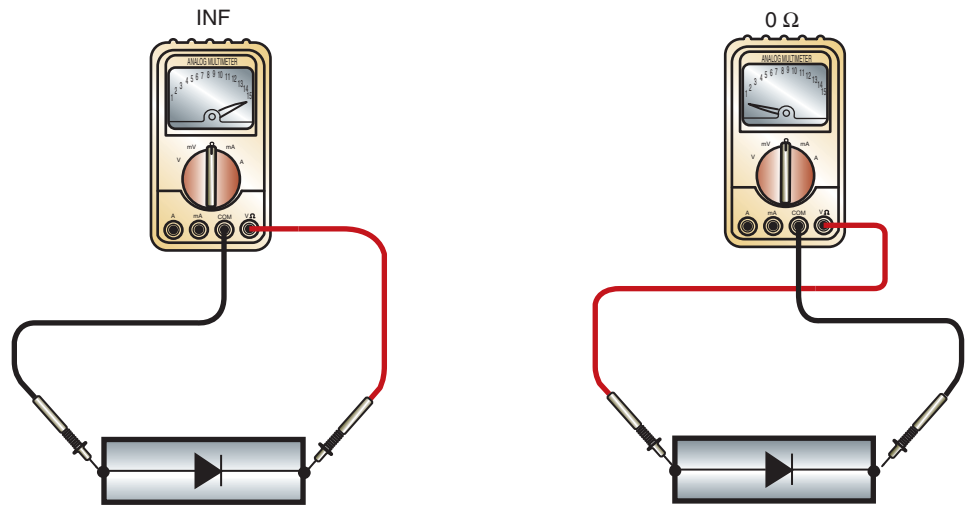


FIGURE 3-32 Use an analog ohmmeter to test a diode for an open and short.

An analog ohmmeter should be used to test a diode. The test current of a digital ohmmeter can pass both ways through a good diode, giving false indications to the technician.

The voltage displayed on the meter is referred to as turn on voltage or diode drop.

**Classroom Manual**  
Chapter 3, page 62

problem, many multimeters are equipped with a diode-testing feature. This feature allows for increased voltage at the test leads. The value displayed is the voltage required to forward bias the diode. A silicon diode should read between 400 and 800 mv in the forward direction and open in reverse. For a germanium diode, it is between 200 and 400 mv in the forward direction. If the diode is open, the meter will display “OL” or another reading to indicate infinity or out-of-range. Some meters during diode check will make a beeping noise when there is continuity.

Diodes may also be tested with a voltmeter. Using the same logic as when testing with an ohmmeter, test the voltage drop across the diode. The meter should read low voltage in one direction and near source voltage in the other direction.

### Testing Zener Diodes

If the Zener diode is out of the circuit and you need to diagnose it for an open or short, then test the Zener as described for the standard diode. However, if you desire to measure its Zener voltage level, you will have to build a test circuit (Figure 3-33). The power supply voltage should be set to a value slightly higher than the Zener value. For example, for a 12-volt diode, the supply voltage should be about 15 volts. This can be made using many styles of “project boxes” from most electronic stores. The value of the resistor R should limit the current to about one milliamp. For example, using 15 volts with a 12-volt Zener, use a 3.3 K resistor.

Once the circuit is built, read the Zener voltage using a digital voltmeter. If the voltmeter indicates 600 mv, the diode is reverse biased and will need to be reinstalled into the circuit.

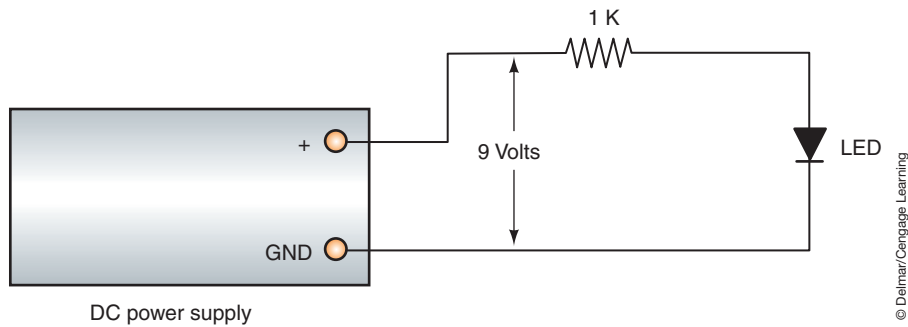
### Testing LEDs

The turn-on voltage of an LED is usually between 1.5 and 2.5 volts. If your DMM has a diode test function, then the LED can be tested in the same manner as a standard diode. The difference will be that the meter will read 1,600 or 50 when the diode conducts instead of the 600 you read on a standard diode.

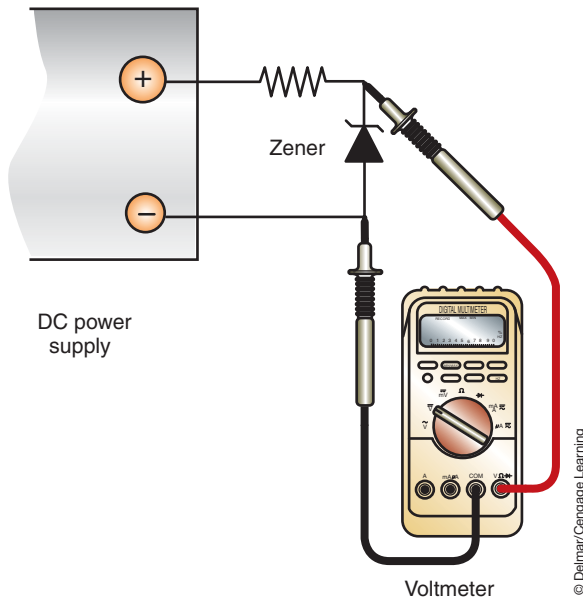
It is possible to test an LED without the use of a DMM. To do this, first build the test circuit as shown (Figure 3-34). By plugging the LED into the circuit, it should light. If the LED doesn't light, then reverse the polarity on the diode. If it still doesn't light, then the LED is faulty.

**Classroom Manual**  
Chapter 3, page 63





**FIGURE 3-33** Making a test power supply to measure Zener voltage.



**FIGURE 3-34** Testing a LED with a test circuit.

## Testing Zener Diodes and LEDs in a Circuit

It is not necessary to remove a Zener diode or the LED from the circuit to test it. To test a Zener, use a voltmeter and measure the voltage across it. Connect the negative lead to the anode and the positive lead to the cathode. The meter should read the Zener voltage. If you read zero volts, the Zener is shorted. This is true if the power and ground circuits to the Zener are confirmed as being good. If the voltmeter reads a voltage that is higher than the Zener's rated voltage, the diode is open.

For an LED that is supposed to be lit but isn't, use a voltmeter to measure the voltage across it. If you measure more than 3 volts, the LED is open.

## TESTING TRANSISTORS

Although replacing a transistor that is part of an integrated circuit board is not often done in the automotive repair industry, some bipolar transistors can be easily tested and replaced. In order to test a bipolar transistor, it is first necessary to identify its type (NPN or PNP) and lead arrangement. To perform this test, it is first necessary to identify the base leg of the transistor. There are several configurations of the transistor legs (Figure 3-35). This can be done using a multimeter. Since transistors behave as back-to-back diodes, the collector and emitter can be identified based on the fact that the doping for the base-to-emitter junction is always much

**Classroom Manual**

Chapter 3, page 64

This discussion is for testing transistors that are out of the circuit only.



## SPECIAL TOOLS

DVOM



### CAUTION:

Do not hold the transistor in your hand while testing it. For every degree the transistor increases in temperature, the base-emitter diode drop decreases by 2 mV. This is a significant amount when determining the base-to-emitter and base-to-collector junctions.

### Classroom Manual

Chapter 3, page 67

Some DVOMs cannot read above 1.2 volts, resulting in a good **Darlington** testing as open. Confirm your DVOM is able to read higher than 1.4 V.



## SPECIAL TOOLS

DSO

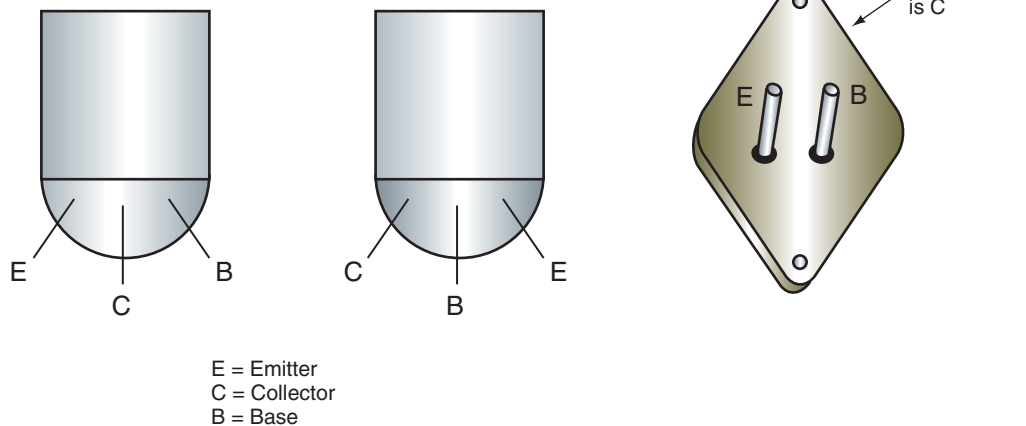


FIGURE 3-35 There are several configurations of the transistor legs.

© Delmar/Cengage Learning

higher than for the base-to-collector junction. Therefore, the forward voltage drop will be a couple of milli volts higher on the DVOM reading when set on the diode test function. Follow Photo Sequence 5 to identify the type of bipolar transistor.

If none of the six possible lead connection combinations indicates a pair of low readings, or if more than one combination results in a pair of low readings, the transistor is probably faulty. Keep in mind that the base-to-collector junction voltage drop is always slightly lower than the emitter-to-base junction drop.

Once the type of transistor is identified, it can be tested using the diode function of the DVOM. Connect the red meter lead to the base of the transistor and the black lead to the emitter. A good NPN transistor will read a voltage of between 450 and 900 mv. A good PNP transistor will read open. With the red lead still on the base, move the black lead to the collector. The reading should be the same as the previous test.

Next, reverse the meter leads and repeat the test. With the black lead connected to the base of the transistor and the red lead to the emitter, a good PNP transistor will read a voltage of between 450 and 900 mv. A good NPN transistor will read open. Leave the black lead on the base and move the red lead to the collector. The reading should be the same as the previous test.

Finally, place one meter lead on the collector, the other on the emitter. The meter should read open. Reverse your meter leads and the meter should read open. This is the same for both NPN and PNP transistors.

## Testing Darlington Transistors

A **Darlington** is a special type of configuration usually consisting of two transistors fabricated on the same chip or mounted in the same package.

Testing is basically similar to that of normal bipolar transistors except that in the forward direction the base-to-emitter reading will be 0.2 to 1.4 volts when reading the DVOM on the diode function. This higher voltage is due to the pair of junctions that are in series.

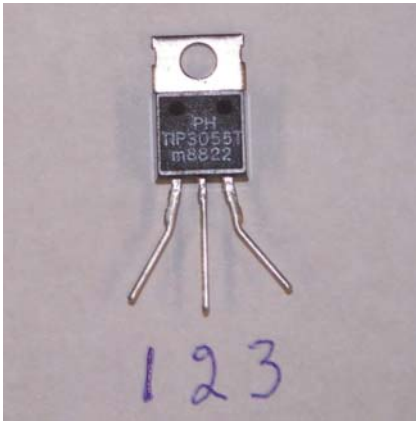
## DIGITAL STORAGE OSCILLOSCOPE (DSO)

The greatest advantage of a DSO is the speed at which it samples electrical signals. Mechanical switching speed of switches and relays is measured in thousands of a second or milliseconds. Electrical/electronic switching speed is measured in millionths of a second or microseconds. Radio frequency interference (RFI) is measured in billionths of a second. The DSO operates at 25 million samples per second. Another method of expressing this operating speed is to say



## IDENTIFYING BIPOLAR TRANSISTORS

All photos in this sequence are © Delmar/Cengage Learning.



**P5-1** Label the pins on the unknown device 1, 2, and 3.



**P5-2** Put the positive probe of the DVOM on pin 1 and measure the diode drop to pins 2 and 3.



**P5-3** If the positive probe is on the base of a good NPN transistor, you should read a low diode drop to pins 2 and 3. The base to collector diode drop will be slightly lower than the base to emitter reading.



**P5-4** If one or both measurements to pins 2 and 3 is/are high, put the positive probe on pin 2 and retest. If still high, put the positive probe on pin 3 and retest.



**P5-5** If the reading is high when all three pins are tested, repeat the tests with the negative probe as the common pin. A pair of low readings now indicates a PNP transistor.



### SERVICE TIP:

Some power transistors have built-in diodes that are reverse biased across the collector-to-emitter junction and resistors between the base-to-emitter junction. The resistor is usually 50 ohms. If not aware of this, you can be confused by the reading if testing the transistor as a standard bipolar transistor. You will need to know the specifications of the power transistor in order to properly test it. Power transistors without internal damper diodes test just about like bipolar transistors.

the DSO is capable of sampling a signal in 40 billionths of a second. DSO sampling speed is at least 47,000 times faster than automotive testers such as other engine analyzers.

This sampling speed allows the DSO to provide an extremely accurate, expanded display of input sensors and output actuators compared to multimeters or other analog scopes. Such increased speed allows the DSO to display glitches or momentary defects in input sensors and output actuators. The extremely fast sampling of the DSO allows this scope to display a graph of input sensor and output actuator operation. Some DSOs have the capability to display two voltage traces across the screen (Figure 3-36). Other DSOs, such as the Simu-Tech, display six voltage traces simultaneously.



© Delmar/Cengage Learning

FIGURE 3-36 Digital storage oscilloscope.



**CAUTION:**

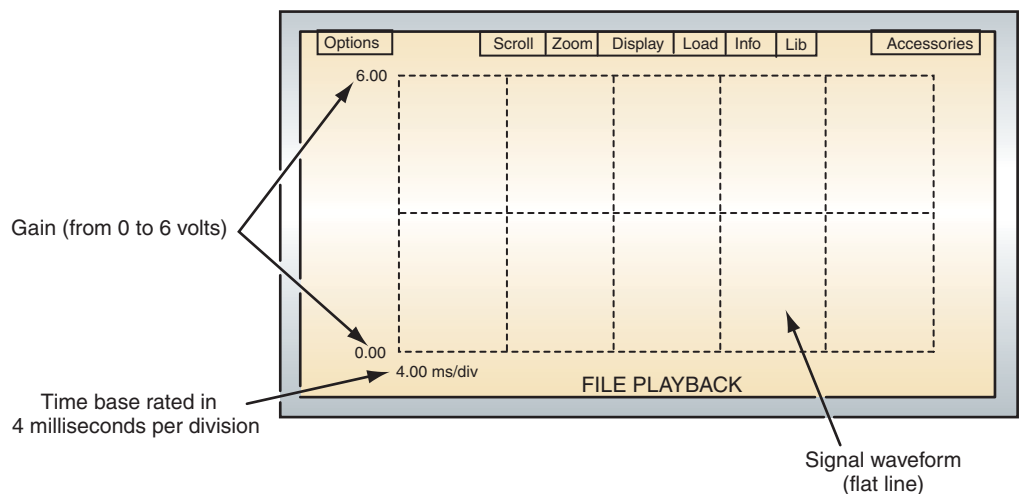
While diagnosing computer systems, always place test equipment, such as DSOs or scan testers, in a secure position where they will not fall on the floor or into rotating components. Severe meter damage may occur if the DSO or scan tester is dropped.

**DSO Screen**

On the DSO screen, voltage is displayed vertically. Voltage change is shown as a vertical movement. Vertical grids on the screen provide a voltage measurement, and the voltage level between the grids is adjustable (Figure 3-37). The technician must know the voltage in the circuit being tested in order to select the voltage per division on the DSO that provides the most detail with the signal remaining on the screen.

Horizontal movement on the screen represents time. The milliseconds per division on the horizontal grid are adjustable with the time button on the DSO. Each time a DSO samples a voltage signal, it displays a dot on the screen. The DSO then connects the dots to provide a waveform. When a faster signal is being read, a shorter time base should be selected on the DSO.

If the time base selected is too long and the voltage too high, the waveform is too small to read. Conversely, if the time base is too short and the voltage scale too low, the waveform is too large for the screen. The technician must select the proper time base for the voltage signal being measured so the waveform is displayed on the screen.



© Delmar/Cengage Learning

FIGURE 3-37 DSO vertical and horizontal screen grids.

## Peak, Average, and Root Mean Square Related to an AC Voltage Waveform

The term **peak** represents the highest point in one cycle of an AC voltage waveform. When both the highest and lowest peaks are considered in an AC voltage waveform, the term **peak-to-peak voltage** is the total voltage measured between these peaks. For example, an AC voltage waveform with a 60-volt peak would have a 120-volt peak-to-peak. The average voltage in an AC voltage waveform is calculated by multiplying  $0.637 \times$  peak voltage. The average voltage on a 60-volt peak would be  $0.637 \times 60 = 38.2$  volts.

In many cases, root mean square (RMS) is used to describe AC voltage. For example, if one cycle of an AC voltage waveform from a 120-volt household electrical outlet is divided into four parts at  $90^\circ$  intervals, the instantaneous voltage and current are recorded for each degree in a  $90^\circ$  interval and then averaged. The square root of the average may be calculated by multiplying  $0.7071 \times$  the peak voltage. The peak voltage for the average 120-volt household outlet is about 170 volts at 60 hertz (Hz). Therefore,  $0.7071 \times 170 = 120.207$  RMS.

### Selecting DSO Voltage and Time Base

To display a waveform for a 120-volt household electrical outlet, round off the peak voltage of 170 to 200 volts. There are eight vertical voltage divisions on the DSO screen with four divisions above and below the centerline. Select 50 volts per division to display the high and low peaks on the waveform. Assuming the 0-volt position in the waveform is positioned in the center of the screen, the 50 volts per division selection provides 200 volts above and below the screen centerline to display the 170-volt peak voltage above and below the centerline. If the volts per division setting is increased, the peaks appear shorter on the screen.

In a 60-Hz AC voltage, one cycle occurs in approximately 18 milliseconds (ms). Displaying one complete AC cycle requires about 20 ms. The average DSO has 10 horizontal divisions. Since  $20 \div 10 = 2$  ms per division, this time base selection displays one AC voltage waveform. If 4 ms per division is selected, 2 AC voltage waveforms are displayed. Increasing the time base displays more AC voltage cycles on the screen. Conversely, decreasing the time base displays fewer AC voltage cycles on the screen, and the waveform appears expanded.

Each time a DSO takes a voltage sample, it displays a dot on the screen and then connects these dots to display a waveform. When the ms time base is too low, the waveform is expanded horizontally and a reduced number of dots are used in the waveform display. This may result in an altered and incomplete waveform display. Ideally, one to three cycles should be displayed on the screen for the best display.

When the DEFAULT button is pressed on some DSOs, a baseline volts per division and ms per division is automatically selected internally. If the volts per division and ms per division selected by the technician are incorrect for the voltage signal being tested, this default mode baseline should provide settings to display a waveform on the screen. Then the volts per division and ms per division may be adjusted to provide the desired display.

### Trigger and Trigger Slope

The trigger selection tells the DSO when to begin displaying a waveform. Until the DSO has a trigger level, it doesn't know when to begin the waveform display. When testing an input sensor that operates in a 0-volt to 5-volt range, select a trigger level of one-half this range.

Trigger slope informs the DSO whether the voltage signal is moving upward or downward when it crosses the trigger level. When a negative trigger slope is selected, the voltage signal is moving downward as it crosses the trigger level. Selecting a positive trigger level results in an upward voltage signal trace when it crosses the trigger level. A marker on the left side of the screen indicates the 0-volt or ground voltage position. This marker may be moved with the DSO controls (Figure 3-38). A second marker at the top of the screen indicates the

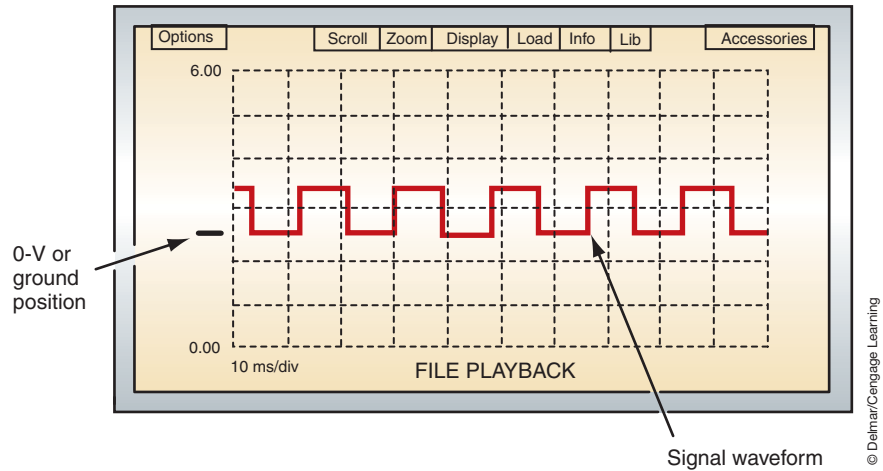


FIGURE 3-38 Ground level reference marker on the left side of the screen.

trigger location. Since the control buttons on DSOs vary, the technician must spend some time to become familiar with a particular DSO.

### Types of Voltage Signals

An **analog signal** is a varying voltage within a specific range over a period of time (Figure 3-39). A throttle position sensor (TPS) produces an analog voltage signal each time the throttle is opened (Figure 3-40).

A **digital signal** is either on or off. It may be described as one that is always high or low. The leading edge of a digital signal represents an increasing voltage, while the trailing edge of the signal represents a decreasing voltage. If the component is turned on by insulated side switching, the line across the top of the leading and trailing edge signals represents the length of component on time, which is called pulse width (Figure 3-41).

The computer measures the distance between the leading edge of a digital signal and leading edge of the next signal to determine the frequency of the waveform. The distance between the leading edge of one digital signal and the leading edge of the next digital signal is referred to as one cycle (Figure 3-42). The computer counts the number of cycles over a period of time to establish the frequency. For example, if 92 cycles are occurring per second, the frequency is 92 hertz (Hz).

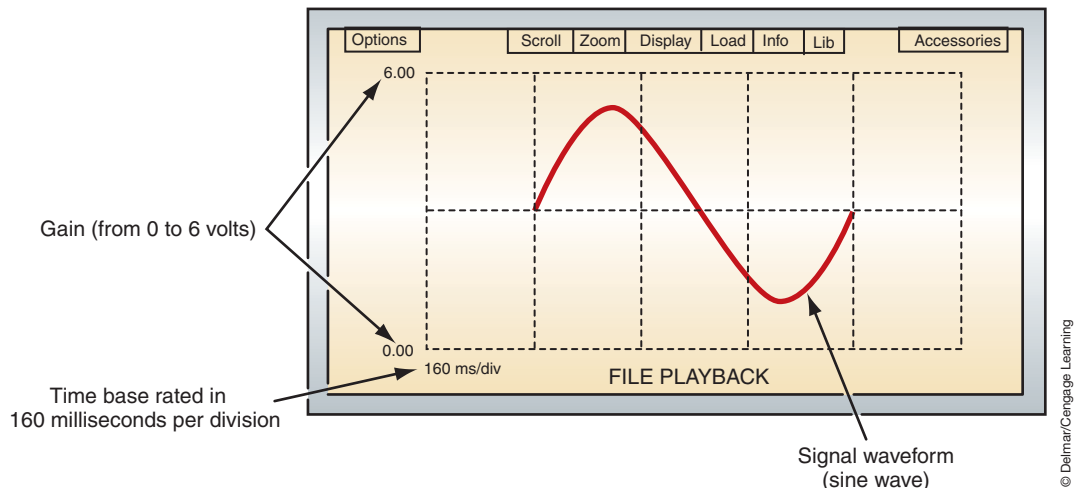
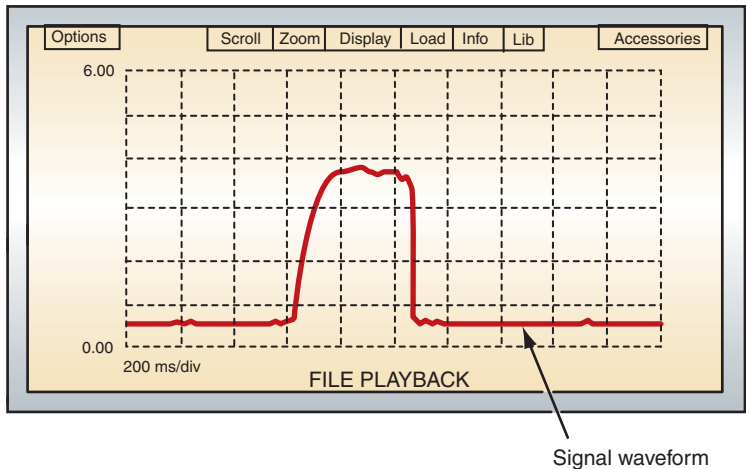
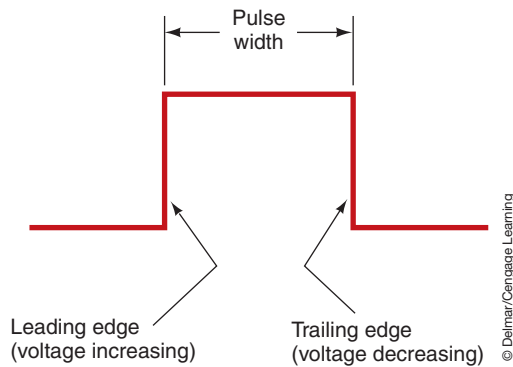


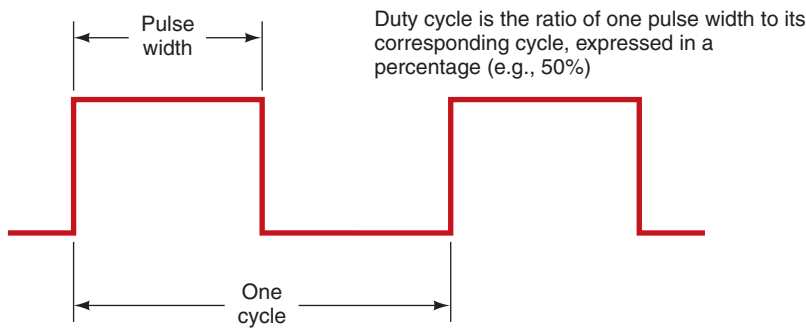
FIGURE 3-39 Analog voltage signal.



**FIGURE 3-40** TPS analog voltage signal.



**FIGURE 3-41** The component on time in a cycle is called pulse width.



With pulse width modulated devices, only the pulse width of the device is changed, not the cycle (the frequency of the signal remains unchanged)

**FIGURE 3-42** The distance between leading edges is one cycle.

The relationship between the on time and off time in a digital signal is called duty cycle. For example, if the component on time and off time are equal, the component has a 50% duty cycle. When the component has a 90% duty cycle, the component is on for 90% of the time in a cycle and off for 10% of the time in a cycle. The computer controls some outputs, such as a carburetor mixture control solenoid, by varying the pulse width while the frequency remains constant.



This type of computer control is referred to as **pulse width modulation (PWM)**. Other outputs, such as fuel injectors, are controlled by varying the frequency and the pulse width.

## User-Friendly DSOs

DSOs with simplified, user-friendly controls have recently been introduced to the automotive service industry. In these DSOs, the auto-range function automatically selects the proper voltage and time base for the signal being received. The technician may use the DSO controls to turn off the auto-range function, and manually select the voltage range and time base.

When the menu key is pressed, various menus are displayed and the vertical arrow keys allow the technician to scroll through the menu to select a specific test. Digital readings are displayed on the screen with most waveforms. For example, minimum, average, and maximum millivolt (mV) readings are provided with an O<sub>2</sub> sensor waveform. The DSO automatically adjusts for zirconia or titania O<sub>2</sub> sensors. This DSO has multimeter and ignition waveform capabilities.

Some user-friendly DSOs, such as the OTC Vision, have a removable application module to help prevent scope obsolescence. A software program card plugs into the bottom of the DSO. This DSO also sets the voltage range and time base automatically for the signal being tested. Four voltage waveforms or six multimeter functions may be displayed on the DSO screen.

## TERMS TO KNOW

Analog signal

Darlington

Digital signal

Diode

Feedback

Fuse

Fusible link

Gauss gauge

Normally open (NO)

Open circuit

Overload

Peak

Peak-to-peak voltage

Potentiometer

Pulse width modulation

(PWM)

Relay

Rheostat

Short to ground

Shorted circuit

Stepped resistor

Variable resistor

## CASE STUDY

A customer brings his vehicle to the shop because the dash lights are not illuminating. The technician checks the fuses and all are good. She then substitutes a bulb, known to be good, in the printed circuit, but it still does not illuminate. Next she uses a voltmeter and checks for applied voltage to the panel light circuit. The test indicates that 12.6 volts are present.

The technician then performs a voltage drop test on the ground side of the circuit and the voltmeter indicates 12.6 volts. She concludes that the printed circuit has an open in the ground side of its circuit. Upon receiving written approval from the customer to perform repairs, she replaces the printed circuit. Verification of the repair confirms her diagnosis.

## ASE-STYLE REVIEW QUESTIONS

1. Circuit defects are being discussed.

*Technician A* says an open can only be on the ground side of the circuit.

*Technician B* says an unwanted resistance can result from a corroded connector.

Who is correct?

- A. A only                      C. Both A and B  
B. B only                      D. Neither A nor B

2. Testing the fuse is being discussed.

*Technician A* says sometimes a visual inspection of a fuse or fusible link does not reveal that it is open.

*Technician B* says to use a jumper wire to bypass the fuse in order to test the circuit.

Who is correct?

- A. A only                      C. Both A and B  
B. B only                      D. Neither A nor B



3. Testing of a switch is being discussed.  
*Technician A* says a switch can be tested with a voltmeter.  
*Technician B* says to use an ohmmeter to test a switch.  
 Who is correct?  
 A. A only                      C. Both A and B  
 B. B only                        D. Neither A nor B
4. *Technician A* says a relay can only be tested while it is connected to the circuit.  
*Technician B* says a stepped resistor can be tested while it is disconnected from the circuit.  
 Who is correct?  
 A. A only                      C. Both A and B  
 B. B only                        D. Neither A nor B
5. An LED does not light. A voltmeter indicates 0 volts across the LED. All of the following can be the cause EXCEPT:  
 A. Current-limiting resistor is open.  
 B. The LED is open.  
 C. Short to ground between the current-limiting resistor and the LED.  
 D. Open ground circuit.
6. Voltage drop testing is being discussed.  
*Technician A* says it is possible to calculate voltage drop by testing for available voltage on both sides of the component.  
*Technician B* says excessive voltage drop can be on either the power side or the ground side of the circuit.  
 Who is correct?  
 A. A only                      C. Both A and B  
 B. B only                        D. Neither A nor B
7. The results of copper-to-copper shorts are being discussed.  
*Technician A* says if there is a short in an electrical motor then the amount of resistance will be higher than specified.  
*Technician B* says a short between circuits can result in both circuits operating by closing one switch.  
 Who is correct?  
 A. A only                      C. Both A and B  
 B. B only                        D. Neither A nor B
8. The testing of a shorted circuit is being discussed.  
*Technician A* says if a fuse blows as soon as it is installed, this indicates a short to ground.  
*Technician B* says if the short to ground is on the ground side of the load component but before a grounding switch, the component will not turn off.  
 Who is correct?  
 A. A only                      C. Both A and B  
 B. B only                        D. Neither A nor B
9. *Technician A* says test the base-collector junction and the base-emitter junction as if they were standard diodes.  
*Technician B* says the resistance between the collector and emitter should read open circuit.  
 Who is correct?  
 A. A only                      C. Both A and B  
 B. B only                        D. Neither A nor B
10. Testing of a potentiometer is being discussed.  
*Technician A* says a voltmeter can be used if jumper wires are connected to the wire connector and sensor to gain access to the test points.  
*Technician B* says the wires can be pierced to test for voltage.  
 Who is correct?  
 A. A only                      C. Both A and B  
 B. B only                        D. Neither A nor B

## ASE CHALLENGE QUESTIONS

- The fuse for an A/C blower motor circuit fails after a short period of time.  
*Technician A* says that the blower motor may be binding internally.  
*Technician B* says that the blower motor ground circuit may have excessive resistance.  
Who is correct?  
A. A only            C. Both A and B  
B. B only            D. Neither A nor B
- Relay testing is being discussed.  
*Technician A* says that it is acceptable during the test sequence to bypass the relay control coil terminals with a fused jumper wire.  
*Technician B* says that the voltage drop across the relay load contact terminals is checked with the relay control circuit de-energized.  
Who is correct?  
A. A only            C. Both A and B  
B. B only            D. Neither A nor B
- The troubleshooting of a parallel circuit that contains three dimly lit bulbs is being discussed. A voltmeter that is placed across each of the bulbs indicates 7.2 volts.  
*Technician A* says that the power supply that is common to all three bulbs may be faulty.  
*Technician B* says that the ground terminal that is common to all three bulbs may have excessive resistance.  
Who is correct?  
A. A only            C. Both A and B  
B. B only            D. Neither A nor B
- An A/C compressor clutch coil spike suppression diode is being tested with an analog ohmmeter. The meter indicates infinite resistance in both directions.  
*Technician A* says that the diode is electrically open.  
*Technician B* says that the use of this diode would result in the failure of the circuit fuse.  
Who is correct?  
A. A only            C. Both A and B  
B. B only            D. Neither A nor B
- How much total resistance is in a 12-volt circuit that is drawing 4 amperes?  
A. 0.333 ohms    C. 4.8 ohms  
B. 3 ohms        D. 48 ohms
- A voltmeter that is connected across the input and output terminals of an instrument cluster illumination lamp rheostat indicates 12.6 volts with the switch in the maximum brightness position and the engine off. Which of the following statements is true?  
A. The voltage available to the lamps will be 12.6 volts.  
B. The voltage available to the lamps will be 0.0 volts.  
C. The rheostat is operating correctly.  
D. More information is required to determine if the lamps will operate correctly.
- The left-rear and right-rear taillights and the left-rear brake light of a vehicle illuminate dimly whenever the brake pedal is pressed; however, the right-rear brake light operates properly.  
*Technician A* says the left-rear taillight and brake light may have a poor ground connection.  
*Technician B* says the brake light switch may have excessive resistance.  
Who is correct?  
A. A only            C. Both A and B  
B. B only            D. Neither A nor B
- The horn of a vehicle equipped with a horn relay sounds weak and distorted. Which of the following is the least likely cause of this problem?  
A. High resistance in the relay load circuit.  
B. High resistance in the horn ground circuit.  
C. Excessive voltage drop between the relay load contact and the horn.  
D. Excessive voltage drop across the relay coil winding.
- The circuit breaker that protects an electric window circuit opens whenever the window is lowered.  
*Technician A* says the internal resistance of the motor is too high.  
*Technician B* says the window regulator may be sticking.  
Who is correct?  
A. A only            C. Both A and B  
B. B only            D. Neither A nor B
- The current draw of a window motor is being measured.  
*Technician A* says the ammeter can be connected on the power side of the motor.  
*Technician B* says the ammeter can be connected on the ground side of the motor.  
Who is correct?  
A. A only            C. Both A and B  
B. B only            D. Neither A nor B

Name \_\_\_\_\_ Date \_\_\_\_\_

## TESTING FOR AN OPEN CIRCUIT

Upon completion of this job sheet, you should be able to test a circuit and locate the open.

### ASE Correlation

This job sheet is related to the ASE Electrical/Electronic System Certification Exam's content area: *General Electrical System Diagnosis*; task: Find shorts, grounds, opens, and high-resistance problems in electrical/electronic circuits and determine needed repairs.

### Tools and Materials

- A vehicle
- DVOM
- Test light
- Wiring diagram for the vehicle

### Describe the vehicle being worked on:

Year \_\_\_\_\_ Make \_\_\_\_\_ Model \_\_\_\_\_  
 VIN \_\_\_\_\_ Engine type and size \_\_\_\_\_

### Procedure

Task Completed \_\_\_\_\_

1. What is the customer's complaint? \_\_\_\_\_  
 \_\_\_\_\_

2. Can the complaint be verified?  Yes  No  
 (If no, consult your instructor.)

3. Are there any other related symptoms?  Yes  No  
 If yes, describe the symptom. \_\_\_\_\_  
 \_\_\_\_\_

4. Following the wiring diagram, use a voltmeter or test light to trace the circuit.

5. Describe the location of the open.  
 \_\_\_\_\_  
 \_\_\_\_\_  
 \_\_\_\_\_

Instructor's Response \_\_\_\_\_  
 \_\_\_\_\_  
 \_\_\_\_\_

*This page intentionally left blank*

Name \_\_\_\_\_ Date \_\_\_\_\_

## TESTING FOR A SHORT TO GROUND

Upon completion of this job sheet, you should be able to test a circuit and locate the short to ground.

### ASE Correlation

This job sheet is related to the ASE Electrical/Electronic System Certification Exam's content area: *General Electrical System Diagnosis*; task: Find shorts, grounds, opens, and high-resistance problems in electrical/electronic circuits and determine needed repairs.

### Tools and Materials

- A vehicle
- DVOM
- Test light
- Circuit breaker fitted with alligator clips
- Gauss gauge
- Wiring diagram for the vehicle

### Describe the vehicle being worked on.

Year \_\_\_\_\_ Make \_\_\_\_\_ Model \_\_\_\_\_  
 VIN \_\_\_\_\_ Engine type and size \_\_\_\_\_

### Procedure

Task Completed

1. Which circuit is affected by the short to ground? \_\_\_\_\_
2. Are there any other related symptoms?  Yes  No  
 If yes, describe the symptom(s).  
 \_\_\_\_\_  
 \_\_\_\_\_
3. Pull the fuse or circuit protection for the affected circuit from the fuse box.
4. With ignition switch in the RUN position, connect the test light across the fuse terminals in the fuse box. Does the test light illuminate?  Yes  No
5. What does this test indicate?  
 \_\_\_\_\_  
 \_\_\_\_\_  
 \_\_\_\_\_
6. With the test light connected across fuse terminals of the fuse box, disconnect components and connectors in the affected circuit that are identified in the wiring diagram.
7. Did the test light go out when a component was disconnected?  Yes  No

---

Task Completed

8. What can be concluded thus far? \_\_\_\_\_

\_\_\_\_\_  
\_\_\_\_\_  
\_\_\_\_\_

9. Connect the test circuit breaker across the fuse terminals of the fuse box and use the Gauss gauge to find the location of the short to ground.

10. Describe the location of the short to ground. \_\_\_\_\_

\_\_\_\_\_  
\_\_\_\_\_  
\_\_\_\_\_

Instructor's Response \_\_\_\_\_

\_\_\_\_\_  
\_\_\_\_\_





---

Task Completed

9. Visually inspect the fuse. Record your findings.

---

---

---

10. Use an ohmmeter and test the fuses. Record your findings.

---

---

---

□

11. Locate a fusible link on the vehicle.

12. Use a voltmeter and measure the voltage drop over the link. Record your results.

---

---

---

13. Disconnect power to the fusible link and use an ohmmeter to test the link. Record your results.

---

---

---

Instructor's Response \_\_\_\_\_

---

---

Name \_\_\_\_\_ Date \_\_\_\_\_

## TESTING SWITCHES

Upon completion of this job sheet, you should be able to test a switch and properly determine needed repairs.

### ASE Correlation

This job sheet is related to the ASE Electrical/Electronic System Certification Exam's content area: *General Electrical System Diagnosis*; task: Check continuity and resistance in electrical/electronic circuits and components with an ohmmeter and determine needed repairs. Check electrical/electronic circuits with jumper wires and determine needed repairs.

### Tools and Materials

- A vehicle
- DVOM
- Test light
- Jumper wires
- Wiring diagram for the vehicle

### Describe the vehicle being worked on:

Year \_\_\_\_\_ Make \_\_\_\_\_ Model \_\_\_\_\_  
 VIN \_\_\_\_\_ Engine type and size \_\_\_\_\_

### Procedure

Task Completed

1. Locate the brake light switch (or other switch as directed by your instructor).
2. Disconnect the switch from the wire harness.
3. Use an ohmmeter to measure the resistance of the switch with the brake pedal released. Record your results. \_\_\_\_\_  
 \_\_\_\_\_
4. With the ohmmeter still connected across the switch terminal, press the brake pedal and record the ohmmeter reading:  
 \_\_\_\_\_
5. Based on your results, is the switch operating properly?  Yes  No  
 Why? \_\_\_\_\_  
 \_\_\_\_\_
6. With the electrical connector to the switch still unplugged, connect a jumper wire across the battery feed and brake light circuits.

7. Do the brake lights come on?  Yes  No

What is the faulty component if the brake lights did not come on with the switch connected and the brakes depressed, but they do come on when jumped across the terminals? \_\_\_\_\_

\_\_\_\_\_

Instructor's Response \_\_\_\_\_

\_\_\_\_\_

\_\_\_\_\_

Name \_\_\_\_\_ Date \_\_\_\_\_

**TESTING A DIODE**

Upon completion of this job sheet, you should be able to test a diode for a short or open.

**ASE Correlation**

This job sheet is related to the ASE Electrical/Electronic System Certification Exam’s content area: *General Electrical System Diagnosis*; task: Check continuity and resistance in electrical/electronic circuits and components with an ohmmeter and determine needed repairs.

**Tools and Materials**

An assortment of diodes  
 Analog ohmmeter  
 DVOM

**Procedure**

Task Completed

1. Which side is the stripe around the diode on?  
 Anode     Cathode
  
2. Using the analog ohmmeter, measure the resistance through the diode by connecting the red test lead to the anode and the black lead to the cathode side of the diode.
  
3. Record your reading. \_\_\_\_\_
  
4. Reverse the test leads so the red test lead is on the cathode and the black lead is on the anode side of the diode.
  
5. Record your reading. \_\_\_\_\_
  
6. What is your conclusion concerning the condition of this diode?  
 \_\_\_\_\_  
 \_\_\_\_\_
  
7. Use the ohmmeter function of the DVOM and measure the resistance in both directions through the diode. Record your results.  
 Forward biased \_\_\_\_\_  
 Reverse biased \_\_\_\_\_
  
8. Are the readings the same as with the analog ohmmeter?     Yes     No
  
9. Explain why a DVOM ohmmeter is not recommended for testing a diode.  
 \_\_\_\_\_  
 \_\_\_\_\_  
 \_\_\_\_\_

**10.** Use a DVOM to test a second diode using the diode test function. Connect the red test lead to the anode and the black lead to the cathode side of the diode. Record the meter readings.

**11.** What does this reading represent?

---

---

**12.** Reverse the test leads across the diode. What is the reading?

---

---

**13.** What does this reading represent?

---

---

**14.** What is your conclusion concerning this diode?

---

---

Instructor's Response \_\_\_\_\_

---

---



Name \_\_\_\_\_ Date \_\_\_\_\_

## USING A DSO ON SENSORS AND SWITCHES

Upon completion of this job sheet, you should be able to connect a DSO and observe the activity of various sensors and switches.

### Tools and Materials

- A vehicle with accessible sensors and switches
- Service information for the above vehicle
- Component locator manual for the above vehicle
- A DSO
- A DMM

### Describe the vehicle being worked on:

Year \_\_\_\_\_ Make \_\_\_\_\_ Model \_\_\_\_\_  
 VIN \_\_\_\_\_ Engine type and size \_\_\_\_\_

### Procedure

1. Connect the DSO across the battery. Make sure the scope is properly set. Observe the trace on the scope. Is there evidence of noise? Explain.

---



---



---



---

2. Locate the A/C compressor clutch control wires. Start and run the engine. Connect the DMM to read available voltage. Observe the meter, then turn the compressor on. What happened on the meter?

---



---

Now connect the DSO to the same point with the compressor turned off. Observe the waveform, then turn the compressor on. What happened to the trace?

---



---

3. Turn off the engine but keep the ignition on. Locate the TP sensor and identify the purpose of each wire to it. List each wire and describe the purpose of each.

---



---

4. Connect the DMM to read reference voltage at the TP sensor. What do you read?

---

---

Now move the leads to read the output of the sensor. Starting with the throttle closed, slowly open the throttle until it is wide open. Watch the voltmeter while doing this. Describe your readings.

---

---

5. Now connect the DSO to read reference voltage at the TP sensor. What do you see on the trace?

---

---

Now move the leads to read the output of the sensor. Starting with the throttle closed, slowly open the throttle until it is wide open. Watch the trace while doing this. Describe your readings.

---

---

6. Now run the engine. Locate the oxygen sensor and identify the purpose of each wire to it. Connect the DMM to read voltage generated by the sensor. (To do this, you may use an electrical connector for the O<sub>2</sub> sensor that is positioned away from the hot exhaust manifold.) Watch the meter and describe what happened below.

---

---

---

7. Now connect the DSO to read voltage output from the sensor. Watch the trace and describe what happened below.

---

---

---

8. Explain what you observed as the differences between testing with a DMM and a DSO.

---

---

---

Instructor's Response \_\_\_\_\_

---

---

<b>DIAGNOSTIC CHART 3-1</b>	
PROBLEM AREA:	Electrical opens.
SYMPTOMS:	Electrical component will not operate.
POSSIBLE CAUSES:	<ol style="list-style-type: none"> <li>1. Broken conductor.</li> <li>2. Defective switch.</li> <li>3. Defective relay.</li> <li>4. Blown fuses.</li> <li>5. Burned fusible links.</li> <li>6. Burned or defective circuit breakers.</li> </ol>

<b>DIAGNOSTIC CHART 3-2</b>	
PROBLEM AREA:	Excessive resistance resulting in lowered electrical output.
SYMPTOMS:	Electrical components fail to operate or operate at reduced efficiency.
POSSIBLE CAUSES:	<ol style="list-style-type: none"> <li>1. Excessive resistance.</li> <li>2. Corroded or damaged conductor.</li> <li>3. Excessive resistance in the switch.</li> <li>4. Excessive resistance in the relay.</li> <li>5. Improper stepped resistor values.</li> <li>6. Defective variable resistor.</li> </ol>

<b>DIAGNOSTIC CHART 3-3</b>	
PROBLEM AREA:	Copper-to-copper short or short to ground.
SYMPTOMS:	No electrical component operation or operation when another control switch is activated.
POSSIBLE CAUSES:	<ol style="list-style-type: none"> <li>1. Broken or burned insulation and/or connectors causing copper-to-copper short.</li> <li>2. Broken or burned insulation and/or connectors causing a short to ground.</li> </ol>

*This page intentionally left blank*

## WIRING REPAIR AND READING CIRCUIT DIAGRAMS



### BASIC TOOLS

Basic mechanic's tool set

Service information

### UPON COMPLETION AND REVIEW OF THIS CHAPTER, YOU SHOULD BE ABLE TO:

- Perform repairs to copper wire using solderless connections.
- Solder splices to copper wire.
- Repair aluminum wire according to manufacturer's requirements.
- Repair twisted/shielded wire.
- Replace fusible links.
- Repair and/or replace the terminals of a hard-shell connector.
- Repair and/or replace the terminals of weather-pack and metri-pack connectors.
- Read a wiring diagram to correctly determine the operation of the circuit.
- Use the wiring diagram to diagnose possible causes for the system fault.

### INTRODUCTION

Many electrical repairs will involve the replacement or repairing of a damaged conductor. To locate the problem area, today's technician must be capable of reading and understanding electrical diagrams and schematics. Once it is determined that the battery is operating correctly, the schematic should always be the starting point in **troubleshooting** an electrical system. Troubleshooting is the diagnostic procedure of locating and identifying the cause of the fault. It is a step-by-step process of elimination by use of cause and effect. By using the schematic, the technician is able to understand how the circuit should work. This is essential before attempting to figure out why it does not work.

The component locator will assist the technician in finding the location of the electrical components shown in the schematic. Many times the component locator will also list the locations of connectors, grounds, and splices.

#### The process of troubleshooting an electrical complaint is as follows:

1. Confirm the complaint. Perform a check of the system to gain an understanding of what is wrong. If the faulty system is monitored by the onboard computer, enter diagnostics to retrieve any **trouble codes**. Trouble codes are the output of the self-diagnostics program in the form of alpha/numeric codes that indicate faulty circuits or components.
2. Study the electrical schematic. This will indicate any shared circuits. Trying to operate the shared circuits will help direct the technician to the problem area. If the shared circuits operate correctly, the problem is isolated to the wiring or components of the problem system. If the shared circuits do not operate, the problem is usually in the power or ground circuit.

3. Locate and repair the fault. By narrowing down the possible causes and taking measurements as required, the fault is located. Before replacing any components, check the ground and power leads. If these are good, then the component is bad.
4. Test the repair. Repeat a check of the system to confirm that it is operating properly.

### Classroom Manual

Chapter 4, page 82



#### CAUTION:

A solid copper wire may be used in low-voltage, low-current circuits where flexibility is not required. Do not use solid wire where high voltage, high current, or flexibility is required, unless solid wire was used by the manufacturer.

### Classroom Manual

Chapter 4, page 87



#### SPECIAL TOOLS

Crimping tool  
Electrical tape or heat shrink tube  
Solderless connector  
Safety glasses  
Fender covers

## WIRE REPAIR

Not all electrical repairs involve removing and replacing a faulty component. Many times the cause of the malfunction is a damaged conductor. The technician must make a repair to the circuit that will not increase the resistance. It should also be a permanent repair. There are many methods to repair a damaged wire. The type of repair used will depend on factors such as:

1. Type of repair required.
2. Ease of access to the damaged area.
3. Type of conductor.
4. Size of wire.
5. Circuit requirements.
6. Manufacturer's recommendations.

The most common methods of wire repair include wrapping damaged insulation with electrical tape or tubing, crimping the connections with solderless connectors, and soldering splices.

## Copper Wire Repairs

Copper wire is the most commonly used primary wire in the automobile. The insulation may break down, or the wire may break due to stress or excessive motion. The wire may also be damaged due to excessive current flow through the wire. Any of these conditions require that the wire be repaired.



**WARNING:** Repair of air bag wiring must be done to manufacturer's specifications.

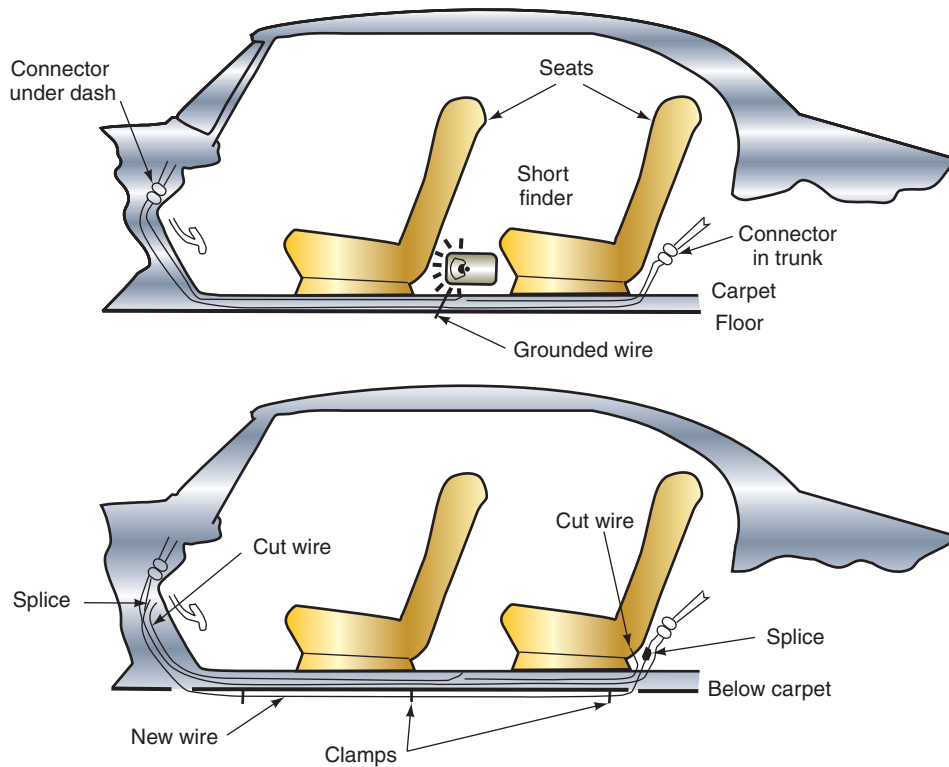
In some instances, it may be necessary to bypass a length of wire that is not accessible. In this case, cut the wire before it enters the inaccessible portion and at the other end where it leaves the area. Install a replacement wire and reroute it to the load component (Figure 4-1). Be sure to protect the wire by using straps, hangers, and grommets as needed.

The two most common methods of splicing copper wire are with solderless connectors or by soldering.

**Crimping.** **Crimping of solderless connectors** is an acceptable method to **splice** wires that are not subjected to weather elements, dirt, corrosion, or excessive movement. Also, do not use crimped connections in electronic circuits. A poor connection, or corrosion over time, can result in improper electronic control operation of the system. Do the following to make a splice using solderless connections:

1. Use the correct size of stripping opening on the crimping tool to remove enough insulation to allow the wire to completely penetrate the connector. The crimping tool has different areas for performing several functions (Figure 4-3). This single tool will cut the wire, strip the insulation, and crimp the connector.
2. Place the wire into the connector and crimp the connector (Figure 4-4). To get a proper crimp, place the open area of the connector facing toward the anvil. Be sure the wire is compressed under the crimp.





**FIGURE 4-1** Routing a new wire to replace a damaged wire that is in an inaccessible location.

© Delmar/Cengage Learning

**Crimping** means to bend, or deform by pinching, a connector so that the wire connection is securely held in place.

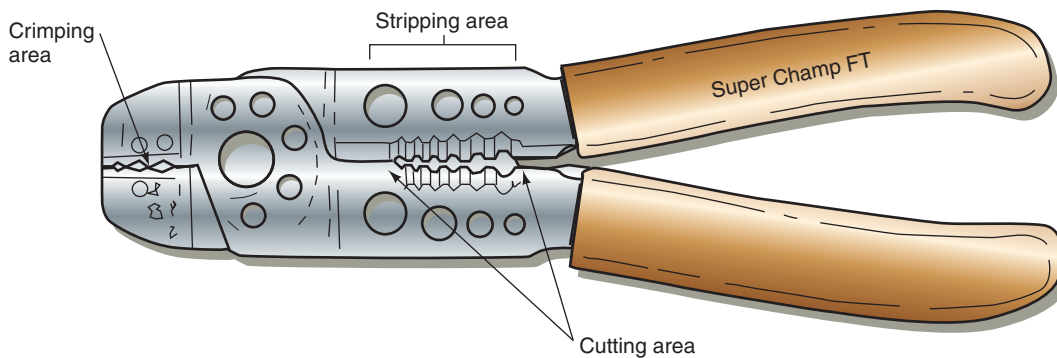
**Solderless connectors** are hollow metal tubes covered with insulating plastic. They can be butt connectors or terminal ends (Figure 4-2).

**Splice** is a term used to mean joining of single wire ends or the joining of two or more electrical conductors at a single point.



**FIGURE 4-2** Types of solderless connectors and terminals commonly used for wire repair.

© Delmar/Cengage Learning



**FIGURE 4-3** A typical crimping tool used for making electrical repairs.

© Delmar/Cengage Learning

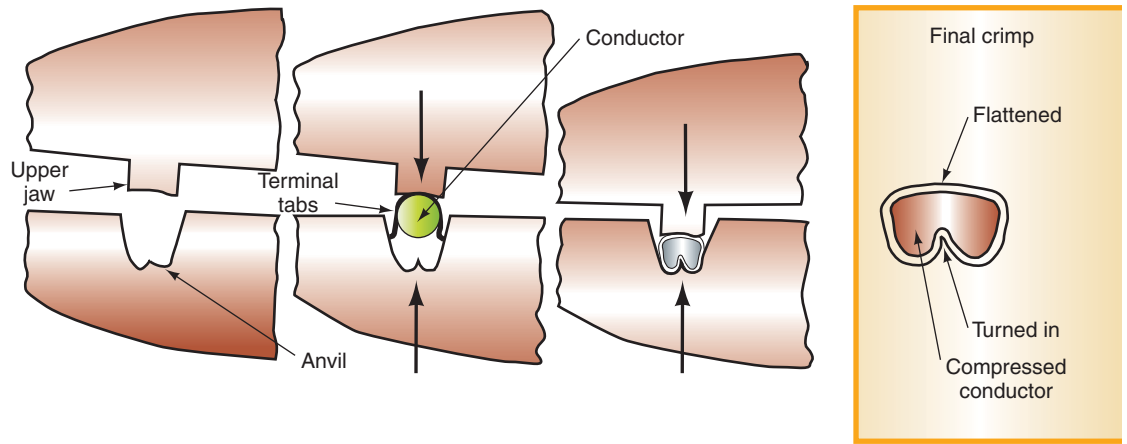


FIGURE 4-4 Properly crimping a connector.

3. Insert the stripped end of the other wire into the connector and crimp in the same manner.
4. Use electrical tape or a piece of heat shrink tube to provide additional protection. Heat shrink tube is plastic tubing that shrinks in diameter when exposed to heat.

Another type of crimping connector is the tap splice connector. This type of connector allows for adding an additional circuit to an existing feed wire without stripping the wires (Figure 4-5). Although tap connectors make connecting wires easy, these should not be used to provide power to critical components. Tap connectors cannot be used on electronic circuits. They are unreliable for making and maintaining a good connection, and their use is discouraged. Also, make sure the fuse of the circuit being tapped into has a large enough capacity before adding the circuit. Tap connectors add a circuit in parallel with another circuit. This causes circuit resistance to decrease and circuit amperage to increase.

### Classroom Manual

Chapter 4, page 87

The process of applying solder to the tip of the iron is called *tinning*.

**Soldering.** Soldering is the best way to splice copper wires. Solder is an alloy of tin and lead. It is melted over a splice to hold the wire ends together. Soldering may be a splicing procedure, but it is also an art that takes much practice. Photo Sequence 6 illustrates the soldering process when using a **splice clip**. A splice clip is a special connector used along with solder to assure a good connection. The splice clip is different from a solderless connection in that it does not have insulation. Some have a hole provided for applying solder (Figure 4-6).

If a splice clip is not used, the wire ends should be braided together tightly. Then the splice should be heated with the soldering gun. It is important to note that when soldering, the solder should melt by the heat of the wire splice, not the heat of the soldering tool. Always use rosin core solder when making electrical repairs. Acid core solder is used for other purposes than electrical repairs and can cause the wire to corrode, which would lead to high resistance.

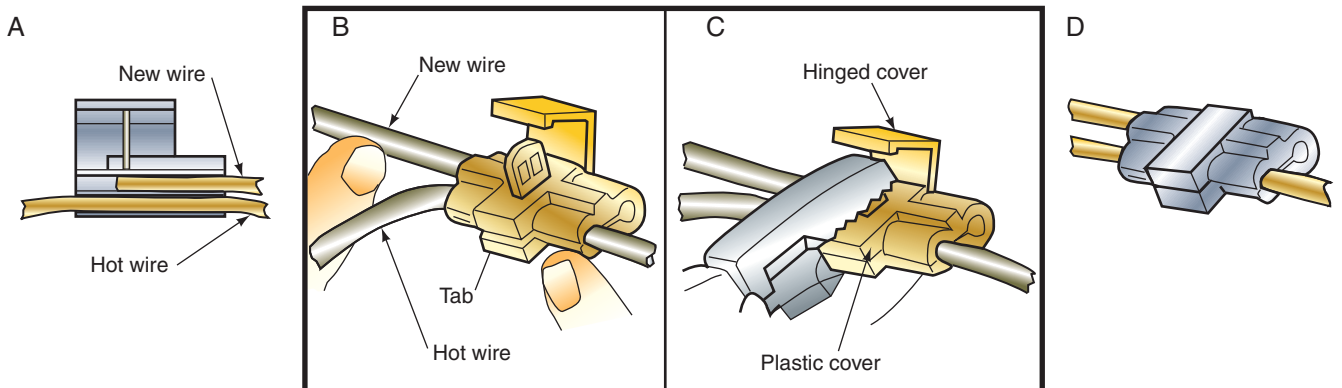


FIGURE 4-5 Using the tap connector to splice in another wire. (A) Place wires in position in the connector, (B) close the connector around the wires, (C) use pliers to force the tab into the conductors, (D) close the hinged cover.

## SOLDERING COPPER WIRE

All photos in this sequence are © Delmar/Cengage Learning.



**P6-1** Tools required to solder copper wire: 100-watt soldering iron, rosin core solder, crimping tool, splice clip, heat shrink tube, heating gun, safety glasses, sewing seam ripper, electrical tape, and fender covers.



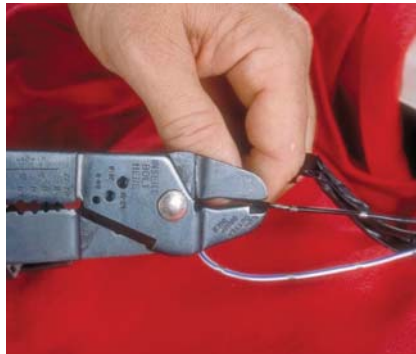
**P6-2** Place the fender covers over the vehicle fenders.



**P6-3** Disconnect the fuse that powers the circuit being repaired. Note: If the circuit is not protected by a fuse, then disconnect the battery.



**P6-4** If the wiring harness is taped, use a seam ripper to open the wiring harness.



**P6-5** Cut out the damaged wire using the wire cutters on the crimping tool.



**P6-6** Using the correct size stripper, remove about 1/2 inch (12mm) of the insulation from both wires. Be careful not to nick or cut any of the wires.



**P6-7** Determine the correct gauge and length of replacement wire.



**P6-8** Using the correct size stripper, remove 1/2 inch (12mm) of insulation from each end of the replacement wire.



**P6-9** Select the proper size splice clip to hold the splice.



## PHOTO SEQUENCE 6 (CONTINUED)

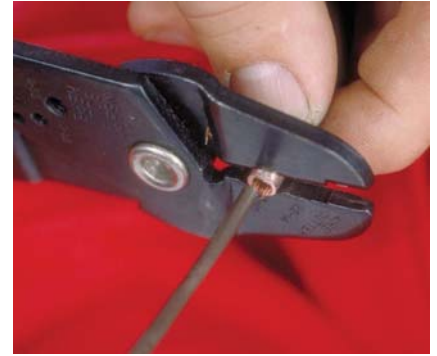
### SOLDERING COPPER WIRE



**P6-10** Place the correct length and size of heat shrink tube over the two ends of the wire. Slide them far enough away so they are not exposed to the heat of the soldering iron.



**P6-11** Overlap the two splice ends and hold in place with thumb and forefinger.



**P6-12** Center the splice clip around the wires and crimp in place. Make sure that wires extend beyond the splice clip in both directions. Crimp the clip on both ends.



**P6-13** Heat the splice clip with the soldering iron while applying solder to the opening in the back of the clip. Do not apply solder to the iron, the iron should be 180 degrees away from the opening of the clip.



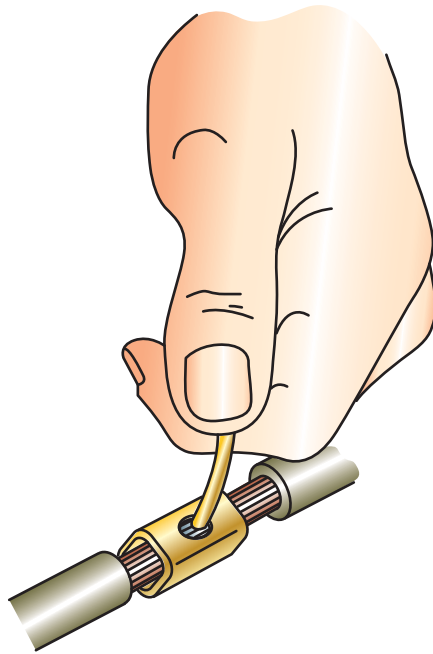
**P6-14** After the solder cools, slide the heat shrink tube over the splice.



**P6-15** Heat the tube with the hot air gun until it shrinks around the splice. Do not overheat the tube.



**P6-16** Re-tape the wiring harness.



© Delmar/Cengage Learning

**FIGURE 4-6** Splice clip. Some have a hole for applying solder.



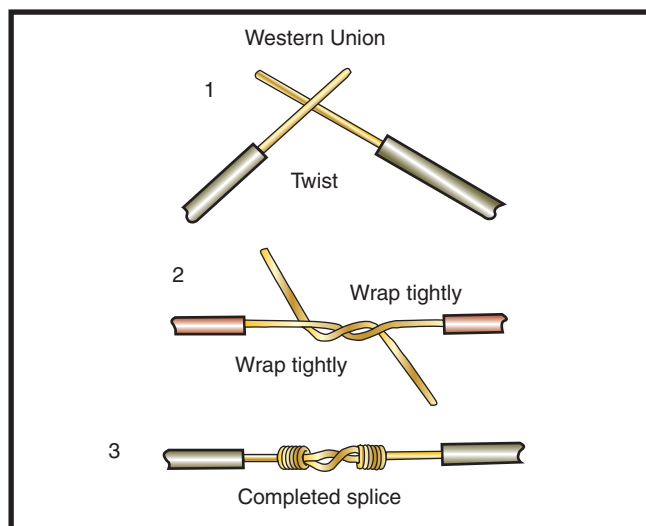
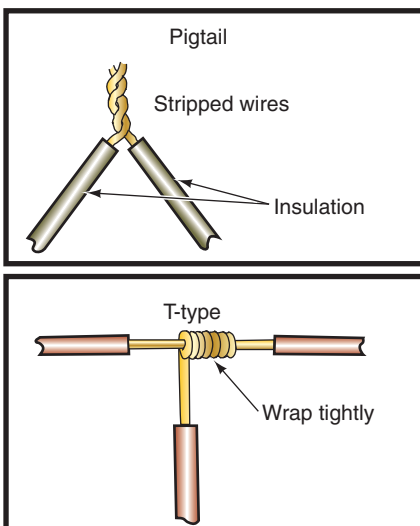
**WARNING:** Before cutting into a wire to make a splice, look for other splices or connections first. Never have two or more splices within 1.5 inches (40 mm) of each other. Also always use wire of the same size or larger than the wire being replaced.



**SERVICE TIP:**

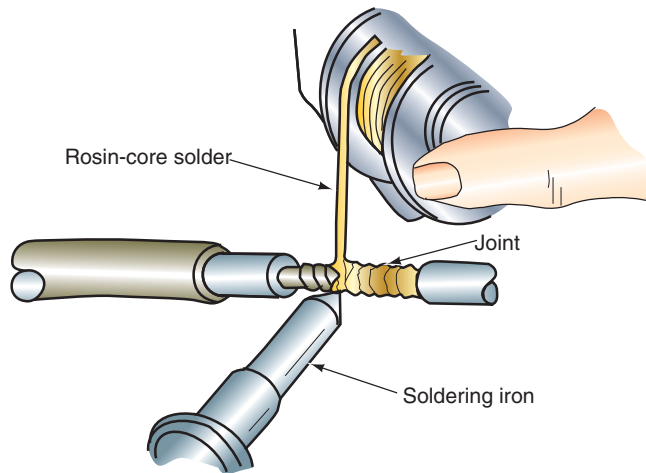
It is easier to heat the wire with the soldering iron if the solder is first melted onto the tip of the iron. This will transfer the heat from the iron to the wire more quickly.

An alternate method of soldering wires together is to use wire joints in place of splice clips. Remove about 1 inch (25 mm) of the insulation from the wires. Join the wires using one of the methods illustrated (Figure 4-7). Heat the twisted connection with the soldering iron. Apply the solder to the strands of wire. Do not apply the solder directly to the soldering iron. The solder should melt and flow evenly among all of the wire strands (Figure 4-8). Insulate the splice with electrical tape or heat shrinking tube.



© Delmar/Cengage Learning

**FIGURE 4-7** Methods for joining wires together.



© Delmar/Cengage Learning

**FIGURE 4-8** When soldering, apply the solder to the joint not to the tip of the soldering iron.



### SPECIAL TOOLS

Crimping tool  
Petroleum jelly  
Safety glasses  
Electrical tape or heat shrink tube



### SPECIAL TOOLS

Crimping tool  
Splice clip  
Wire strippers  
100-watt soldering gun  
Fender covers  
Safety glasses  
60/40 rosin core solder  
Heat shrink tube  
Heat Gun



### CAUTION:

When repairing the wires, stagger the splice connections. This will prevent shorts.

## Repairing Aluminum Wire



**WARNING:** Attempting to solder aluminum wire will damage the conductor.

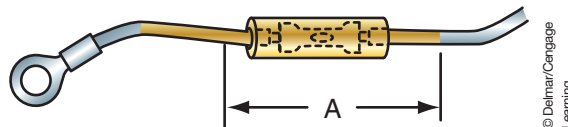
General Motors has used single-stranded aluminum wire in limited applications where no flexing of the wire is expected. This wire usually has a thick plastic insulator and is placed in a brown harness.

After cutting away the damaged wire, strip all wire of the last 1/4 inch (6 mm) of insulation. Be careful not to nick or damage the conductor. Apply a generous coating of petroleum jelly to the wire and connector (Figure 4-9). The petroleum jelly will prevent corrosion from developing in the core.

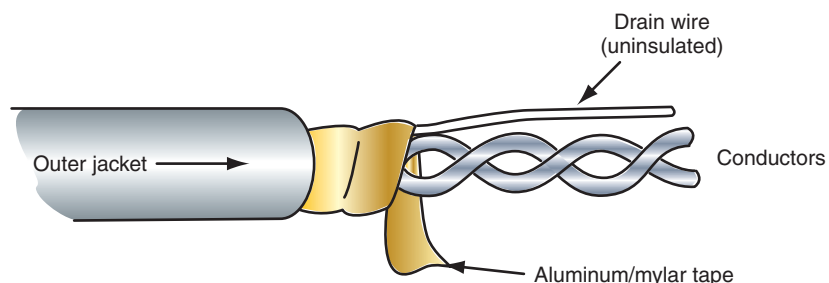
Crimp the connector in the usual manner. Insulate the splice with heat shrink tube. Do not use electrical tape since it will not stay in place due to the petroleum jelly.

## Splicing Twisted/Shielded Wire

Twisted/shielded wire is used in some computer circuits. It protects the circuit from electrical noise that would interfere with the operation of the computer controls (Figure 4-10). These wires may carry as low as 0.1 ampere of current. It is important that the splice made in these wires does not have any resistance. The added resistance may give false signals to the computer or actuator. Photo Sequence 7 illustrates the procedure for splicing shielded wire.



**FIGURE 4-9** Apply petroleum jelly to the areas shown.



© Delmar/Cengage Learning

**FIGURE 4-10** Twisted/shielded wire used in computer circuits.



## SPLICING SHIELDED WIRES

All photos in this sequence are © Delmar/Cengage Learning.



**PS7-1** Tools required to perform this task include a crimping tool, splice clip, wire strippers, soldering gun, rosin core solder, heat shrink tube, heat gun, and safety glasses.



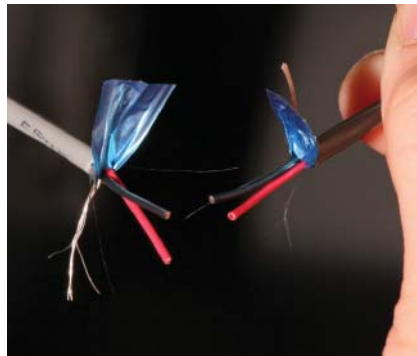
**PS7-2** Locate and cut out the damaged section of wire.



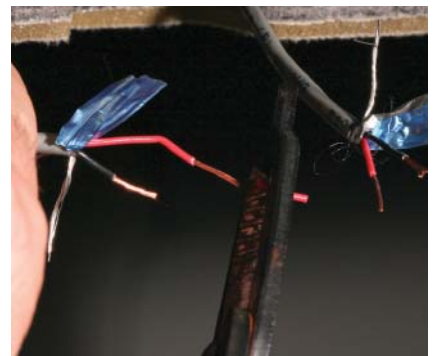
**PS7-3** Being careful not to cut into the Mylar tape or to cut the drain wire, remove about 1 inch (25mm) of the outer jacket from the ends of each cable.



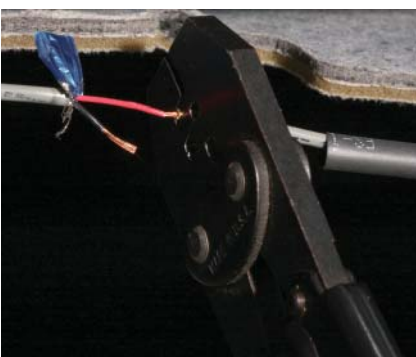
**PS7-4** Unwrap the Mylar tape. Do not remove the tape from the cable.



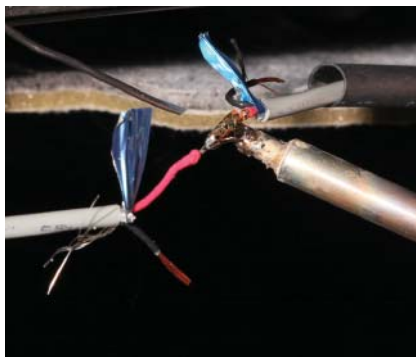
**PS7-5** Untwist the conductors.



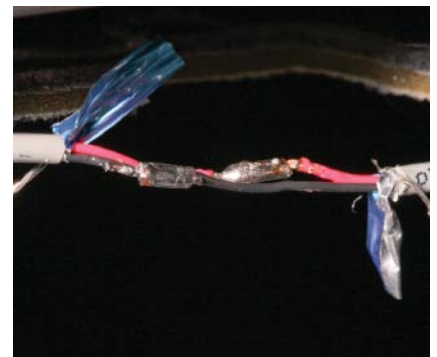
**PS7-6** Remove a small amount of the insulation from the ends of the conductors. The conductor ends should be staggered so that the splices will not be on top of each other. Also, the heat shrink tube should be located over the cable, but away from the work area.



**PS7-7** Locate a splice clip over the two ends of the conductors.



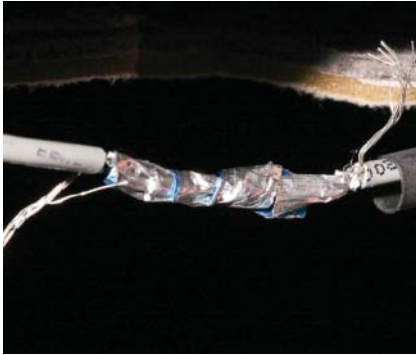
**PS7-8** Solder the splice.



**PS7-9** Repeat for the splice and solder procedure for the second conductor. Make sure that the two splices will not touch each other.

## PHOTO SEQUENCE 7 (CONTINUED)

### SPlicing SHIELDED WIRES



**PS7-10** Wrap the conductors with the Mylar tape. Do not wrap the drain wire in the tape.



**PS7-11** Wrap the drain wire around the outside of the Mylar tape.



**PS7-12** Splice the drain wire with a clip and solder.



**PS7-13** Locate the heat shrink tube over the splice area and use the heat gun to shrink the tube over the cable.

#### Classroom Manual

Chapter 3, page 72



#### SPECIAL TOOLS

Crimping tool  
100-watt soldering iron  
60/40 rosin coresolder  
Safety glasses  
Fender covers

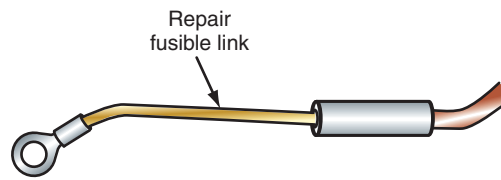
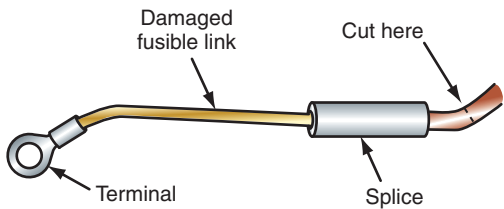
### REPLACING FUSIBLE LINKS

Not all fusible link open circuits are detectable by visual inspection only. Test for battery voltage on both sides of the fusible link to confirm its condition. If the fusible link must be replaced, it is cut out of the circuit and a new fusible link is crimped or soldered into place.

There are two types of insulation used on fusible links: Hypalon and Silicone/GXL. Hypalon can be used to replace either type of link. However, do not use Silicone/GXL to replace Hypalon. To identify the type of insulation, cut the blown link's insulation back. The insulation of the Hypalon link is a solid color all the way through. The insulation of Silicon/GXL will have a white inner core.

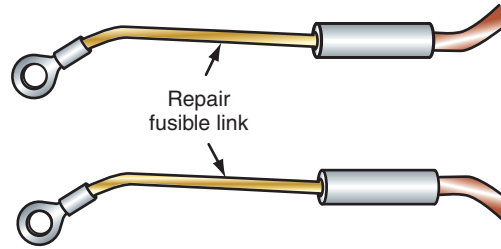
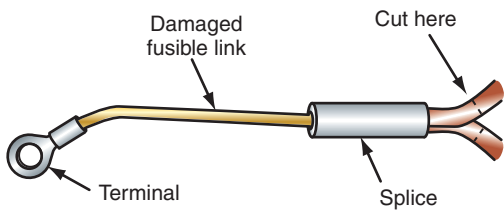
When cutting off the damaged fusible link from the feed wire, cut it beyond the splice (Figure 4-11). When making the repair link, do not use a fusible link that is cut longer than 9 inches (228 mm). This length will not provide sufficient overload protection. Splice in the repair link by crimping or soldering.

If the damaged fusible link feeds two harness wires, use two fusible links. Splice one link to each of the harness wires (Figure 4-12).



© Delmar/Cengage Learning

**FIGURE 4-11** Replacing a fusible link.



© Delmar/Cengage Learning

**FIGURE 4-12** Replacing a fusible link that feeds two circuits.

**CUSTOMER CARE:** If the fusible link or any of the fuses are blown, it is important to locate the cause. Fuses do not wear out. If they blow, it is due to an overload of current in the circuit. By using a cause-and-effect diagnosis approach, the fault can be identified and repaired the first time the vehicle is in the shop. The following illustrates how to use this method:

Effect	Cause
Turn signals not operating	Blown fuse
Blown fuse	Short to ground
Short to ground	Broken wire in trunk
Broken wire	Loose jack handle

This method led the technician to fix the fault and find the cause.

## REPAIRING CONNECTOR TERMINALS

The connector terminal is subjected to needed repairs due to abuse, improper disconnecting procedures, and exposure potential to the elements. The method of repair depends on the type of connector.

### Molded Connectors

If the connector is a one-piece, molded-type connector, it cannot be disassembled for repairs (Figure 4-13). Although the connector halves can be separated, the connector itself cannot be disassembled. If the connector is damaged, it must be cut off and a new connector spliced in.



### CAUTION:

Disconnect the battery negative cable before performing any repairs to the fusible link.



### CAUTION:

Use the fusible link gauge required by the manufacturer.

**Classroom Manual**

Chapter 4, page 87



© Delmar/Cengage Learning

**FIGURE 4-13** Molded connector halves are a one piece design that cannot be disassembled for repairs.

**Classroom Manual**

Chapter 4, page 89



**SPECIAL TOOLS**

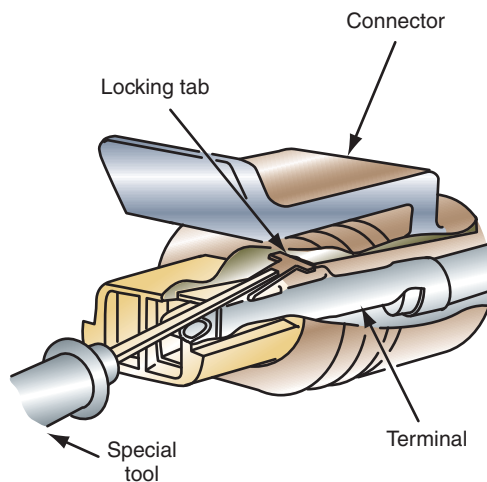
- Pick
- Crimping tool
- Safety glasses
- Fender covers

## Hard-Shell Connectors



**WARNING:** Do not place your fingers or body next to the connector. If excessive force is needed to depress the tang, the pick may be pushed out the back and cause injury.

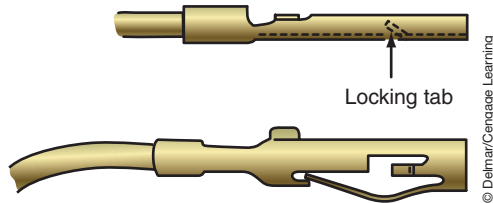
Hard-shell connectors usually provide a means of removing the terminals for repair. Use a pick, or the special tool, to depress the locking tang of the connector (Figure 4-14). Pull the lead back far enough to release the locking tang from the connector. Remove the pick, then pull the lead completely out of the connector. Make the repair to the terminal using the same procedures for repairing copper or aluminum wire.



Push narrow pick between terminal and connector body.

© Delmar/Cengage Learning

**FIGURE 4-14** Depress the locking tang to remove the terminal from the connector.



**FIGURE 4-15** Reform the locking tang to its original position before inserting the terminal back into the connector.

Re-form the terminal locking tang to assure a good lock in the connector (Figure 4-15). Use the pick to bend the lock tang back into its original shape. Insert the lead into the back of the connector. A noticeable “catch” should be felt when the lead is halfway through the connector. Gently push back and forth on the lead to confirm that the terminal is locked in place.

## Weather-Pack Connectors

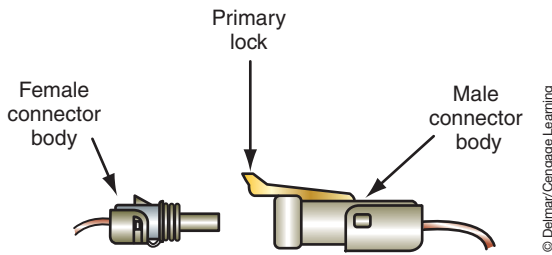
The terminals of the weather-pack connector are secured by a hinged secondary lock or a plastic terminal retainer. To perform repairs, first disconnect the two halves by pulling up on the primary lock while pulling the two halves apart (Figure 4-16). Unlock the secondary locks and swing them open (Figure 4-17).

Depress the terminal locking tanks using the special weather-pack tool. Push the cylinder of the tool into the terminal cavity from the front until it stops (Figure 4-18). Pull the tool out, then gently pull the lead out of the back of the connector (Figure 4-19).

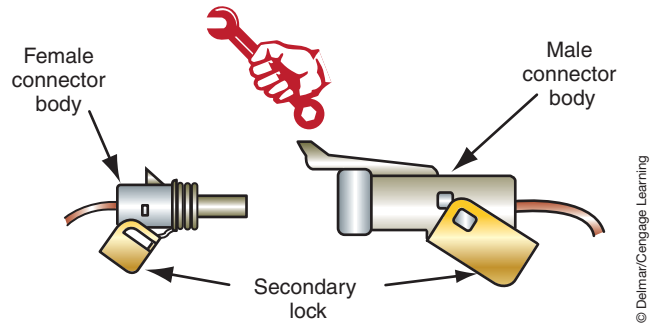
**Classroom Manual**  
Chapter 4, page 89

### SPECIAL TOOLS

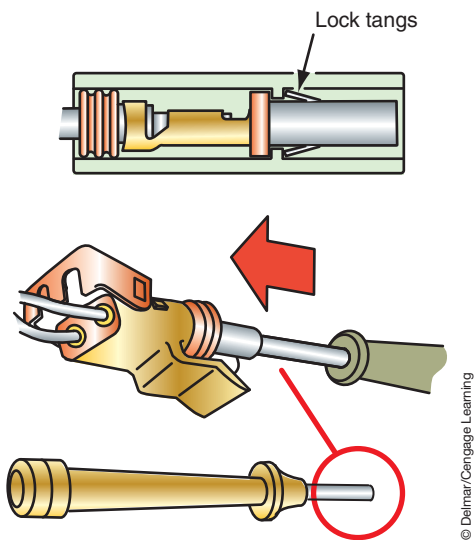
- Weather-pack tool
- Crimping tool
- Safety glasses
- Fender cover



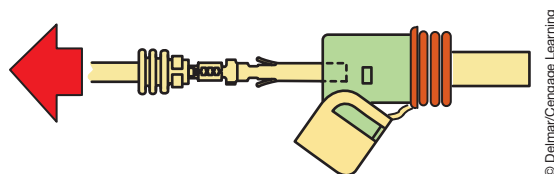
**FIGURE 4-16** The weather-pack connector has two locks. Use the primary lock to separate the halves.



**FIGURE 4-17** Unlock the secondary lock to remove the terminals from the connector.



**FIGURE 4-18** Use the recommended special tool to unlock the tang on the terminal.



**FIGURE 4-19** After the lock tang has been depressed, remove the lead from the back of the connector.





**SERVICE TIP:**

Use a weather-pack repair kit that provides new seals for a complete repair.

The terminal is either a male or female connector (Figure 4-20). Use the correct terminal for the repair. Feed the wire through the seal and connect the repair lead in the normal manner of crimping and soldering (Figure 4-21). Re-form the terminal lock tang by bending it back into its original position (Figure 4-22).

Insert the lead from the back of the connector until a noticeable “catch” is felt. Gently push and pull on the lead to confirm that it is locked to the connector. Close the secondary locks and reconnect the connector halves.

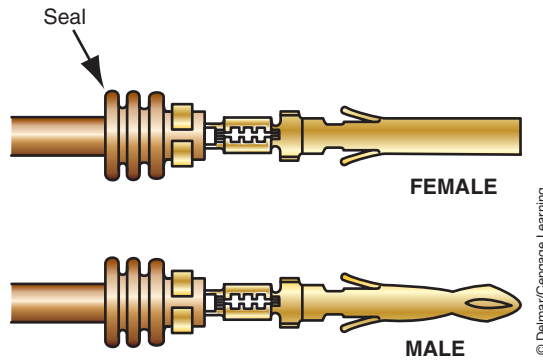


FIGURE 4-20 Male and female connectors.

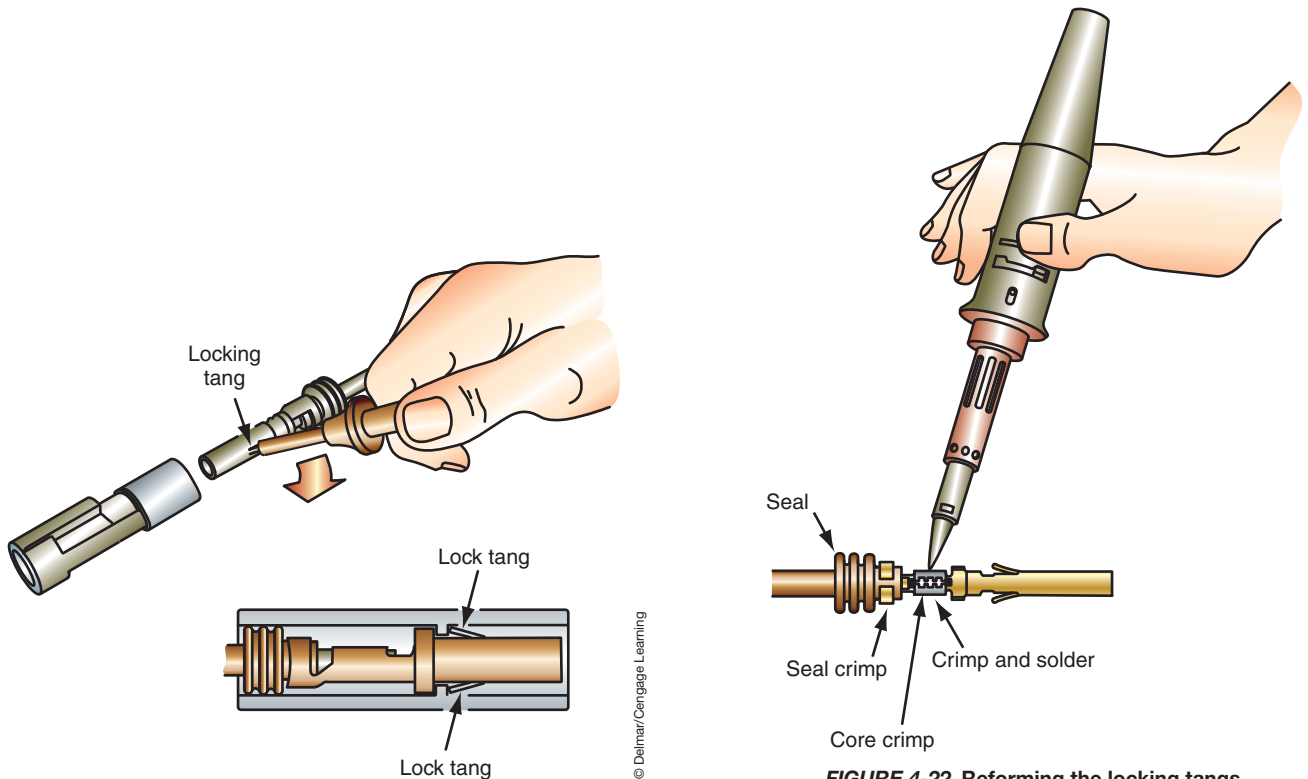


FIGURE 4-21 Crimp and solder the terminal to the lead.

FIGURE 4-22 Reforming the locking tangs of the terminal.

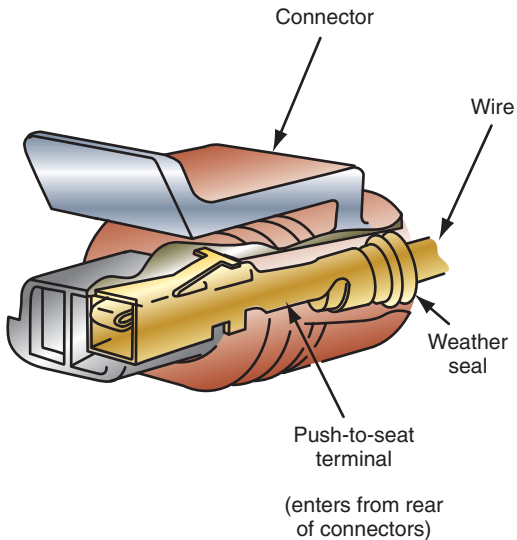


## Metri-Pack Connectors

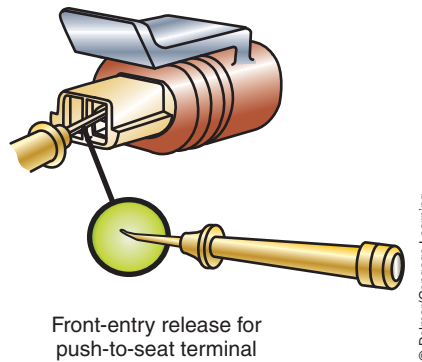
There are two types of metri-pack connectors: **pull to seat** and **push to seat**. The push-to-seat terminal removal is illustrated (Figures 4-23 and 4-24).

The pull-to-seat terminal is removed by inserting a pick into the connector and under the lock tang (Figure 4-25). Gently pull back on the lead while prying up on the lock tang. When the lock tang is free of the tab in the connector, push the lead through the *front* of the connector.

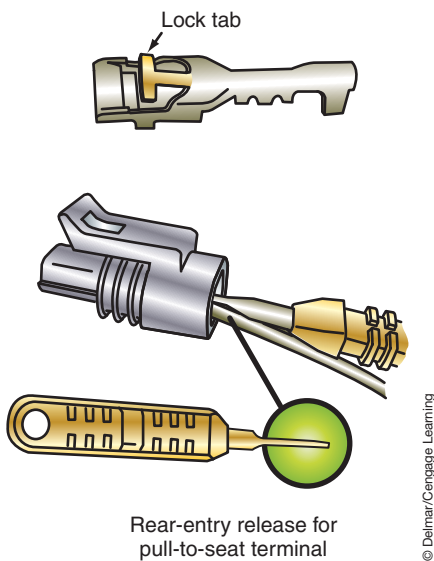
To make the repairs to the terminal, insert the stripped wire through the seal and the connector body (Figure 4-26). Crimp and solder the terminal to the wire. Pull the wire lead and terminal back into the connector body until the terminal is locked (Figure 4-27).



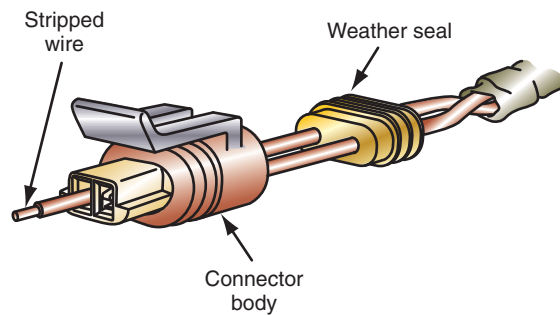
**FIGURE 4-23** Use a wide pick to unlock the male terminal locking tang.



**FIGURE 4-24** Use a wide pick to unlock the nib of the terminal retainer for female terminals.



**FIGURE 4-25** Pull up on the lock tang to release the terminal from the connector.



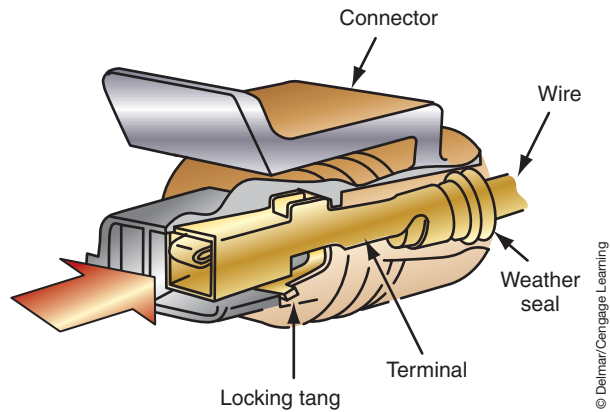
**FIGURE 4-26** The wire lead must be installed into the seal and connector before attaching the terminal.



### SPECIAL TOOLS

- Pick
- Crimping tool
- Safety glasses
- Fender covers

The connectors are called **pull to seat** or **push to seat** to depict the method used to install the terminals into the connector.



**FIGURE 4-27** Make sure that the terminal locks into the connector body.

**Classroom Manual**

Chapter 4, page 85



**SPECIAL TOOLS**

DMM  
Lab scope



**SERVICE TIP:**

When troubleshooting an intermittent electrical problem, be sure to check the condition of *all* ground straps on the vehicle.

**Classroom Manual**

Chapter 4, page 93

## GROUND STRAPS

**Ground straps** between the powertrain components and the vehicle's chassis are used to complete the return path to the battery. Ground straps are also used to connect sheet metal parts even though there is no electrical circuit involved to suppress EMI since the sheet metal could behave as a large capacitor and the resulting electrostatic field can interfere with computer-controlled circuits.

Like any other conductor, resistance or opens in the ground strap, or its connections, can cause multiple issues. For example, the engine starter may not engage or crank slow, fuel injectors may not properly energize, and ignition coils may not function.

If electron flow cannot return through the designed ground path, it will attempt to find an alternate path. Sometimes this may be evidenced by pitting of the slip yoke at the rear of the transmission or by pitting of wheel bearings. This pitting is the result of arcing as the current jumps from one component to another and wears away the metal.

Ground straps that are used for electrical circuits can be tested using the voltage drop test. Each connection of the ground strap should have a voltage drop of zero volts. In addition, the ground strap itself should have no voltage drop between its ends. Be sure to confirm that the connection terminals are tight and clean. It is a good practice to use the voltage drop test to confirm proper connections anytime the ground strap is removed and re-installed.

Ground straps that are used to control EMI generally do not have electrical circuits involved so a voltage drop test would not be possible. However, a voltmeter or lab scope set on the lowest scale may pick up any voltage that is passing through the strap. Also, an ohmmeter can be used to measure the resistance between connector ends.

## READING WIRING DIAGRAMS

When attempting to locate a possible cause for system malfunction, it is important to have the correct wiring diagram for the vehicle being worked on. There may be a different diagram for each model and even for the same models equipped with different options. Also, diagrams may differ between two- and four-door models. In some cases, it may be necessary to use the date of manufacture and/or the **vehicle identification number (VIN)** to determine the correct diagram to use. The VIN is assigned to a vehicle for identification purposes. The identification plate is usually located on the cowl, next to the left upper instrument panel (Figure 4-28). It is visible from the outside of the vehicle. Other locations for the VIN plate are in the door opening, glove box, and engine compartment.

Next, study the method used to identify circuits and **color codes**. Usually this information is provided in the service information. Color codes are used to assist in tracing the wires. In most color codes, the first group of letters designates the base color of the insulation and the



© Delmar/Cengage Learning

**FIGURE 4-28** VIN plate location.

second group of letters indicates the color of the tracer. Also become familiar with the electrical symbols used by the manufacturer.

Before you begin to try to use a wiring diagram, you must first have an idea of what you are looking for. It may be a particular component, circuit, or connector. The best way to start the process is by identifying the component or one of the components that doesn't work correctly. Then look in the index for the wiring diagram and find where that component is shown.

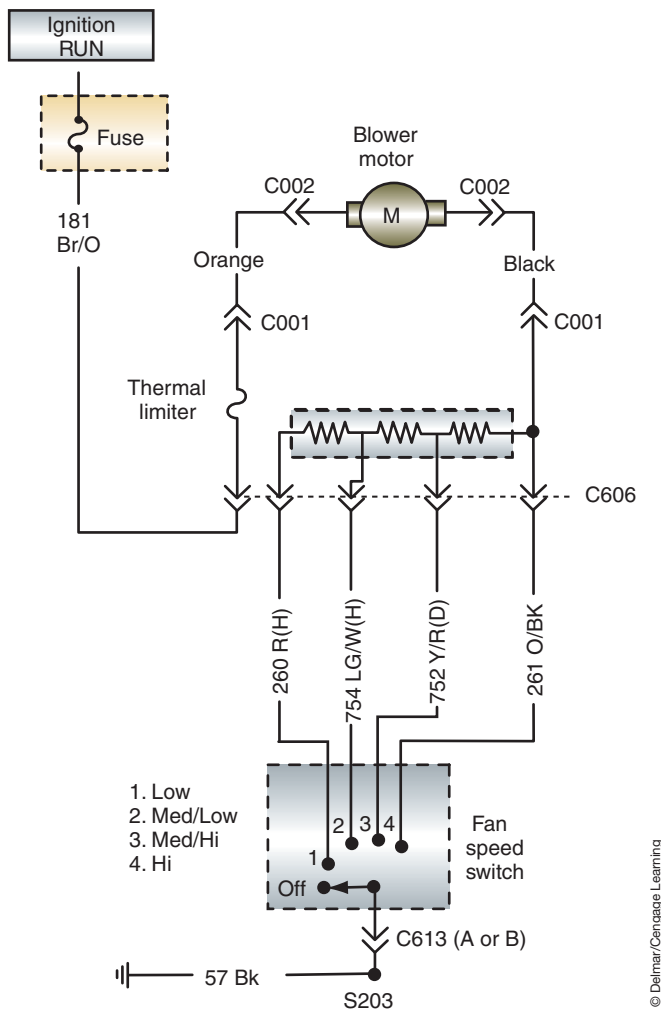
The electrical section in most service informations breaks down the electrical system of the automobile into individual circuits. This approach makes it easier to find a particular component. Of course, you still need to use the index to find the page the component and its circuit is on. Computer-driven wiring diagrams may provide a search feature. This makes locating the component within the wiring diagrams much easier and faster.

If the service information uses a total vehicle wiring diagram, finding the component may be a little trickier. Wiring diagrams are usually indexed by grids. The diagram is marked into equal sections like a street map. The wiring diagram's index will list a letter and number for each major component and many different connection points. If the wiring diagram is not indexed, you can locate the component by relating its general location in the vehicle to a general location on the wiring diagram. Most system diagrams are drawn so the front of the car is on the left of the diagram.

Once you have found the component or part of the circuit you were looking for, identify all of the components, connectors, and wires that are related to that component. This is done by tracing through the circuit, starting at the component. Tracing does not mean taking a pencil and marking on the wiring diagram. Tracing means taking your pencil and drawing out the circuit on another piece of paper. It doesn't have to be pretty to work; it just needs to be accurate. Tracing may also mean taking your finger and following the wires to where they lead. In order for tracing to have any value, you need to identify the power source for the component and/or for the circuit, all related loads (sometimes this involves tracing the circuit back through other pages of the wiring diagram), and the ground connection for the component and for all of the related loads.

After you have traced the circuit, study it and make sure you know how the circuit is supposed to work. Then describe the problem you are hoping to solve. Ask yourself what could cause this. Limit your answers to those items in your traced wiring diagram. Also, limit your answers to the description of the problem. It is wise to make a list of all probable causes of the problem; then number them according to probability. For example, if no dashlights come on, it is possible that all of the bulbs are burned out. However, it is not as probable as a blown fuse. After you have listed the probable causes in order of probability, look at the wiring diagram to identify how you can quickly test to find out which is the cause. Diagnostics is made easier as your knowledge of electricity grows. It also becomes easier with a good understanding of how the circuit works.

Figure 4-29 is a schematic for a blower control circuit of a heater system. By tracing through the circuit, the technician should be able to determine the correct operation of the system. It cannot be overemphasized that the technician should not attempt to figure out why the circuit is not working until it is understood how it is supposed to work.



**FIGURE 4-29** Heater system wiring diagram.

© Delmar/Cengage Learning

In this circuit, battery voltage is applied to the fuse box where the 30-ampere fuse supplies the battery voltage to the motor through circuit number 181. Notice that circuit 181 connects to the blower motor resistor block through connector C606. When it leaves the resistor block (after flowing through the thermal limiter) it goes through connector C001 and attaches to the motor through connector C002. Details of these connectors are shown with the schematic.

The circuit then leaves the motor and enters the resistor block through the same connectors. There is a splice in the resistor block that connects this wire to a series of resistors. Connector C606 directs the various circuits out of the resistor block to the blower switch and ground through connector C613. If the switch is placed in the OFF position, the circuit to ground is opened and the blower motor should not operate. If the switch is placed in the LOW position, the current will flow through all of the resistors and the switch through circuit 260. The switch completes the circuit to ground. As the switch is placed in different speed positions, the amount of resistance and the circuit number change. The motor speed should increase as the amount of resistance decreases.

If the customer complains that the heater motor does not work at all, in any speed position, consider the following possible causes:

1. Open fuse.
2. Open in the lead from the battery to the fuse box.
3. Bad ground connection after the switch.
4. Inoperative blower motor.
5. Open in circuit 181.

6. Open in the orange wire between connectors C001 and C002.
7. Open thermal limiter.
8. Open in the black wire between connectors C002 and C001.
9. Disconnected, damaged, or corroded connector C606 or C613.
10. Faulty switch.

However, if the customer complains that the motor will not operate in the low position only, the problem is limited to three possibilities:

1. The third resistor in the series is open.
2. An open in circuit 260 from the resistor block to the blower switch.
3. A faulty switch.

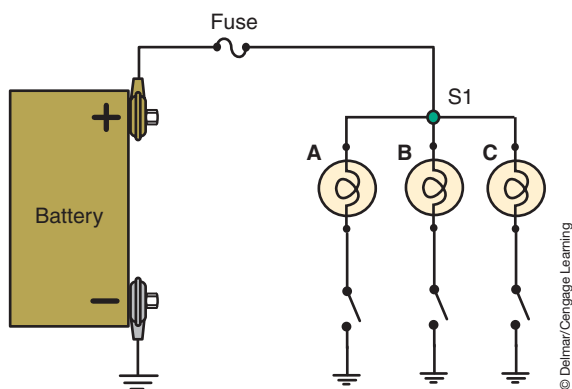
Once the potential problem areas are determined, use the color code to locate the exact wires. Test the leads for expected voltages at different locations in the circuit.

By understanding the way the system is supposed to work, the problem of determining where to look for the problems is simplified. Practice in reading wiring schematics is the only good teacher.

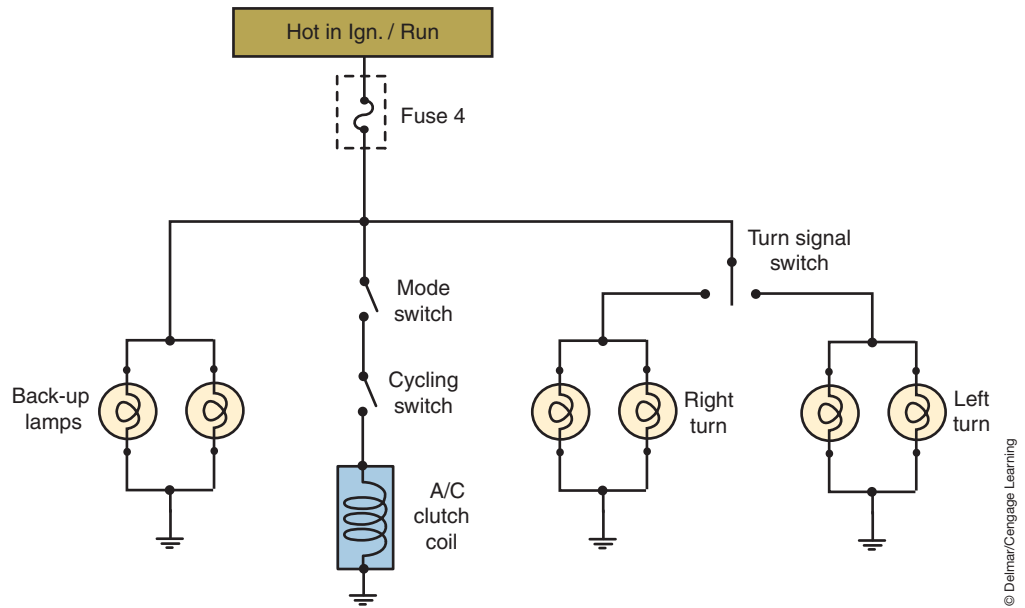
The example just discussed hopefully has given an understanding of the advantages to using a wiring diagram before actually performing diagnostic tests. Today's vehicles have an ever-increasing number of electrical accessories and include the use of computer modules to perform many tasks. When the manufacturers design the vehicle, many of the electrical circuits are constructed in a parallel arrangement. All of this combines to make the electrical circuits more challenging to diagnose. Proper use of the wiring diagram can help you to get the diagnosis accomplished intelligently.

To illustrate again how the proper use of the wiring diagram helps to make intelligent diagnostics, consider a simple parallel circuit (Figure 4-30). In this circuit, the fuse is series wired to the three parallel lamps. The common components of this circuit include the fuse and the conductors connecting the battery to the point identified as S1. After the S1 splice location, the three lamps branch off. If lamp A is the only nonfunctioning component of the circuit, by using the wiring diagram you should be able to determine possible fault areas very quickly. If lamps B and C both function, the open must be beyond common-point S1. However, if none of the lamps function, the open is probably before the common point. By using the wiring diagram, diagnostic time has been saved by not having to test half of the circuit.

**AUTHOR'S NOTE:** This type of diagnostic procedure of using the wiring diagram to isolate possible fault locations is sometimes referred to as "common-point diagnostics."



**FIGURE 4-30** Example of using the wiring diagram to locate an open.



**FIGURE 4-31** Example of using the wiring diagram to locate a short.

© Delmar/Cengage Learning

In the previous examples of wire diagram usage, we focused mainly on locating opens or faulty components. The wiring diagram is also an excellent tool for locating shorts to ground. Consider the circuit shown in Figure 4-31 and assume that fuse 4 is blown. Knowing that the fuse blows as a result of excessive current flow in the circuit that can result from a short to ground condition, you need to isolate the location of the short.

Fuse 4 in this circuit protects many parallel circuits that encompass a wiring harness that goes from the front to the rear of the vehicle. To trace out the circuits within the harness would be very time consuming. Using the wiring diagram and common-point diagnosis will identify the most likely location of the short.

The first step is to isolate the faulty circuit. Turn off all loads that are protected by fuse 4. With all circuits turned off, there should be no current flow through the circuit. Remove the fuse and insert a test light across the fuse box terminals. This installs the test light in series with the circuit. Turn the ignition switch to the RUN position and observe the test light. If the test light is illuminated, the short is in the common circuit between the fuse and the switches. In this instance, you would then be looking for a short in the dashboard area after the fuse and before the individual circuit switches. The next step would be to separate the connectors one at a time to see if the test light goes out. This will isolate the circuit further.

If the test light did not illuminate when the ignition switch was placed in the RUN position, the location of the short is after the common circuit and the switches. Replace the fuse with a new properly rated fuse and turn on each circuit separately until the fuse blows. The short would be in the section of the circuit that, when energized, caused the fuse to blow.

Keep in mind, the customer may have brought this vehicle in because the A/C was not working. If all that you did was replace the fuse and it did not blow when the A/C was turned on, you missed the fact that the fuse will blow when the back-up lamp switch is closed. Without referencing the wiring diagram, it is possible to make the assumption that there is an intermittent short in the A/C circuit or within the compressor clutch. Remember, one of your diagnostic steps is to determine related symptoms and that the last step is to verify your repair as successful.



## TERMS TO KNOW

Color codes  
Crimping  
Crimping tool  
Ground straps  
Heat shrink tube  
Pull to seat  
Push to seat  
Solderless connectors  
Splice  
Splice clip  
Trouble codes  
Troubleshooting  
Vehicle identification number (VIN)

## CASE STUDY

The vehicle owner complains that the brake lights do not light. He also says the dome light is not working. The technician verifies the problem, then checks the battery for good connections and tests the fusible links. All are in good condition.

A study of the wiring diagram indicates that the brake light and dome light circuits share the same fuse. It is also indicated that the ignition switch illumination light circuit is shared with these two circuits. A check of the ignition switch illumination light shows that it is not operating either. The technician checks the fuse

that is identified in the wiring diagram. It is blown. When a replacement fuse is installed, the dome and brake lights work properly for three tests, then the fuse blows again.

Upon further testing of the shared circuits, an intermittent short to ground is located in the steering column in the ignition switch illumination circuit. The technician solders in a repair wire to replace the damaged section. After all repairs are completed, a final test indicates proper operation of all circuits.

## ASE-STYLE REVIEW QUESTIONS

- Splicing copper wire is being discussed.  
*Technician A* says it is acceptable to use solderless connections.  
*Technician B* says acid core solder should not be used on copper wires.  
Who is correct?  
A. A only                      C. Both A and B  
B. B only                      D. Neither A nor B
- Use of wiring diagrams is being discussed.  
*Technician A* says a wiring diagram is used to help find the fault.  
*Technician B* says the wiring diagram will give the exact location of the components in the car.  
Who is correct?  
A. A only                      C. Both A and B  
B. B only                      D. Neither A nor B
- The fuse for the parking lights is open.  
*Technician A* says find the cause for the blown fuse.  
*Technician B* says the fuse probably wore out due to age.  
Who is correct?  
A. A only                      C. Both A and B  
B. B only                      D. Neither A nor B
- Repairs to a twisted/shielded wire are being discussed.  
*Technician A* says a twisted/shielded wire carries high current.  
*Technician B* says because a twisted/shielded wire carries low current, any repairs to the wire must not increase the resistance of the circuit.  
Who is correct?  
A. A only                      C. Both A and B  
B. B only                      D. Neither A nor B
- Replacement of fusible links is being discussed.  
*Technician A* says not all open fusible links are detectable by visual inspection.  
*Technician B* says to test for battery voltage on both sides of the fusible link to confirm its condition.  
Who is correct?  
A. A only                      C. Both A and B  
B. B only                      D. Neither A nor B
- Technician A* says troubleshooting is the diagnostic procedure of locating and identifying the cause of the fault.  
*Technician B* says troubleshooting is a step-by-step process of elimination by use of cause and effect.  
Who is correct?  
A. A only                      C. Both A and B  
B. B only                      D. Neither A nor B

7. *Technician A* says a replacement fusible link should be at least 9 inches (25 mm) long.  
*Technician B* says if the damaged fusible link feeds two harness wires, use one replacement fusible link.  
Who is correct?  
A. A only                    C. Both A and B  
B. B only                    D. Neither A nor B
8. Repairing connectors is being discussed.  
*Technician A* says molded connectors are a one-piece design and cannot be separated for repairs.  
*Technician B* says to replace the seals when repairing the weather-pack connector.  
Who is correct?  
A. A only                    C. Both A and B  
B. B only                    D. Neither A nor B
9. *Technician A* says all metri-pack connectors use male terminals.  
*Technician B* says the connectors of the metri-pack are called pull to seat or push to seat to depict the method used to install the terminals into the connector.  
Who is correct?  
A. A only                    C. Both A and B  
B. B only                    D. Neither A nor B
10. *Technician A* says there may be a different wiring diagram for each model of a vehicle.  
*Technician B* says it may be necessary to use the VIN number to get the correct wiring diagram for the vehicle.  
Who is correct?  
A. A only                    C. Both A and B  
B. B only                    D. Neither A nor B

## ASE CHALLENGE QUESTIONS

1. *Technician A* says that acid core solder should be used whenever copper wires are to be soldered.  
*Technician B* says that solderless connectors should not be used if a weather-resistant connection is desired.  
Who is correct?  
A. A only                    C. Both A and B  
B. B only                    D. Neither A nor B
2. Which of the following electrical troubleshooting routines is in the correct sequence?  
A. Study the electrical diagram, confirm the complaint, locate and repair the fault, test the repair.  
B. Study the electrical diagram, locate and repair the fault, confirm the complaint, test the repair.  
C. Confirm the complaint, study the electrical diagram, test the repair, locate and repair the fault.  
D. Confirm the complaint, study the electrical diagram, locate and repair the fault, test the repair.
3. Wire repair procedures are being discussed.  
*Technician A* says the aluminum wire should never be soldered; it should only be crimped whenever repairs are necessary.  
*Technician B* says that damaged twisted/shielded wires should be connected with splice clips and then the connections should be soldered.  
Who is correct?  
A. A only                    C. Both A and B  
B. B only                    D. Neither A nor B
4. *Technician A* says that when replacing a fusible link the gauge size of the replacement fusible link can be decreased but never increased.  
*Technician B* says that a 14-gauge fusible link can be replaced with an equivalent length of 14-gauge stranded wire.  
Who is correct?  
A. A only                    C. Both A and B  
B. B only                    D. Neither A nor B
5. *Technician A* says that a wire identified as “754 LG/W (H)” on a wiring diagram refers to a wire located in circuit 754 that is light green with white hash marks.  
*Technician B* says that a wire that is labeled 181 BR/O refers to an 18-gauge wire that is brown with an orange stripe.  
Who is correct?  
A. A only                    C. Both A and B  
B. B only                    D. Neither A nor B
6. Using Figure 4-32, what would be the LEAST likely cause for fuse 16 blowing?  
A. A short to ground between terminal 2 of the fuse and terminal 86 of the relay.  
B. A short to ground between terminal 85 of the relay and terminal 47 of the IMP.  
C. A short to ground at terminal 30 of the relay.  
D. A short to ground in circuit X2.

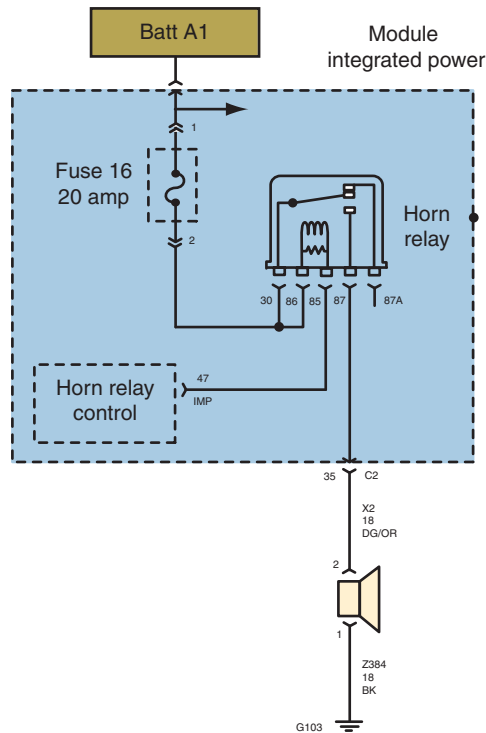


FIGURE 4-32

© Delmar/Cengage Learning

7. A customer states that their tail lamps are not functioning. When testing the lamp operation, it is noted that the tail/stop lamps and the turn signals do not operate. During the diagnostic routine, the technician also notices that the back-up lamps are also not functioning. All fuses test good. Using all of the wiring diagrams with indicated test voltages in Figure 4-33a through d, what is the most likely cause of this condition?
  - A. G301 is open.
  - B. G302 is open.
  - C. Faulty Integrated Power Module.
  - D. Open in the Z918 circuit.
8. Referring to Figure 4-34, how is the blower speed controlled?
  - A. The A/C–Heater Controller uses a high-side driver for each speed circuit.
  - B. The Totally Integrated Power Module uses PWM to control the ground circuit of the motor.
  - C. A/C–Heater Controller uses a low-side driver for each speed circuit.
  - D. All of the above.
9. Referring to the wiring diagram illustrated in Figure 4-35a through d, the fog lights do not work when the headlight switch is in the AUTO position, but work in the HEAD and PARKLAMP positions. What is the most likely cause?
  - A. Open in the headlamp switch resistor between the 3 and 6 positions.
  - B. Open in the resistor below the 3 position of the headlamp switch.
  - C. Short to ground in circuit L80.
  - D. Short to voltage at terminal 4 of headlamp switch.
10. Referring to Figure 4-36a through d, the coil for cylinder 4 and the injector for cylinder 3 both fail to function. What is the possible cause?
  - A. Poor connection at splice S134.
  - B. Open in the K13 circuit.
  - C. Poor connection in the S185 splice.
  - D. Open in circuit between S184 and PCM C1/38 terminal.

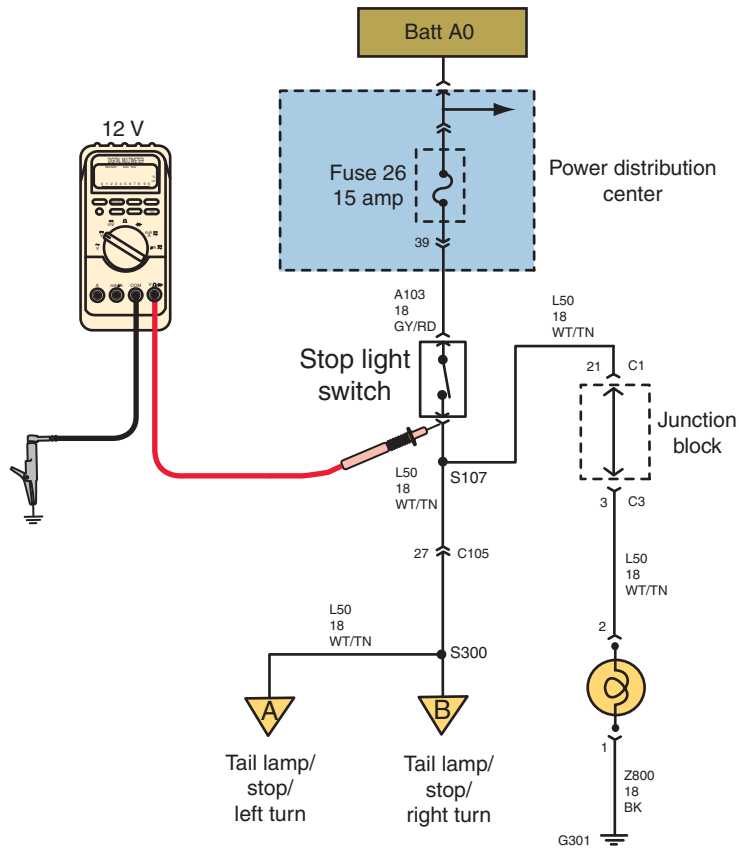


FIGURE 4-33a

© Delmar/Cengage Learning

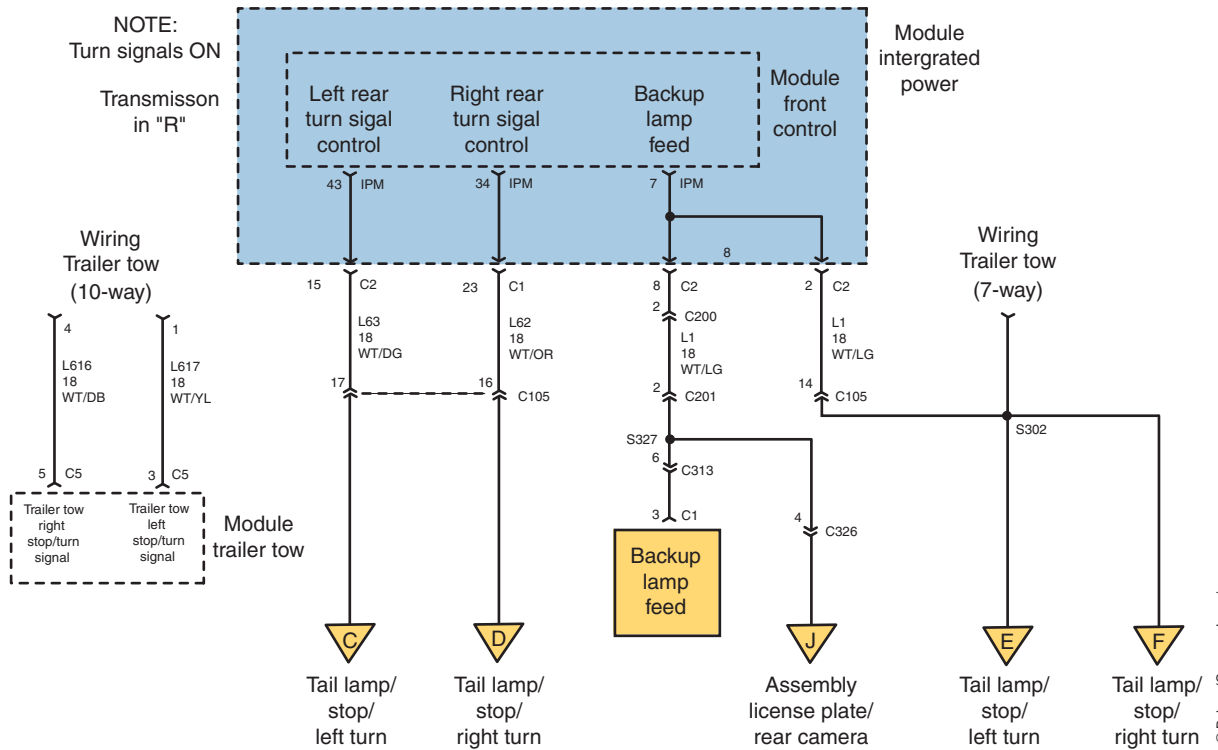


FIGURE 4-33b

© Delmar/Cengage Learning

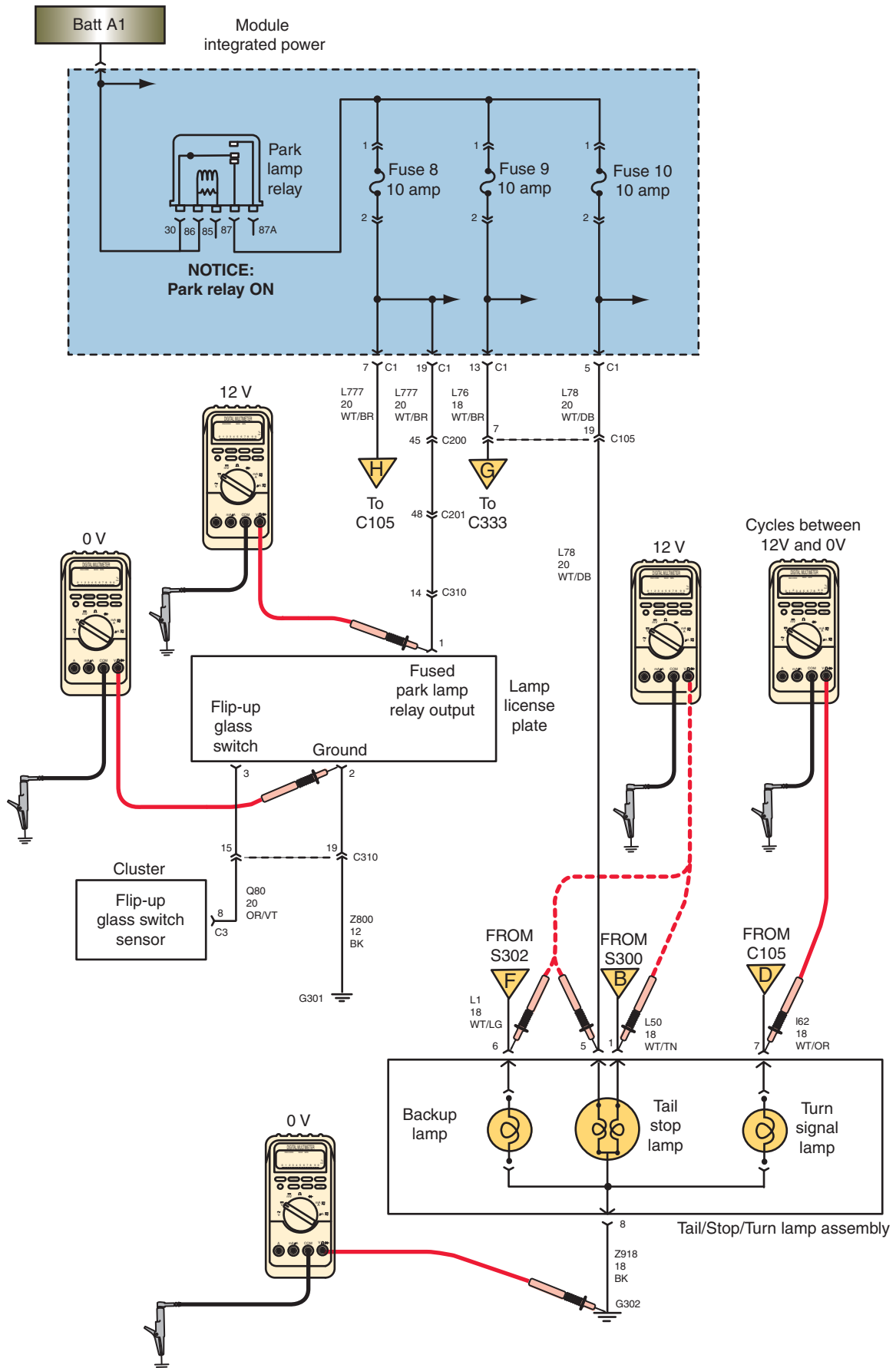


FIGURE 4-33c

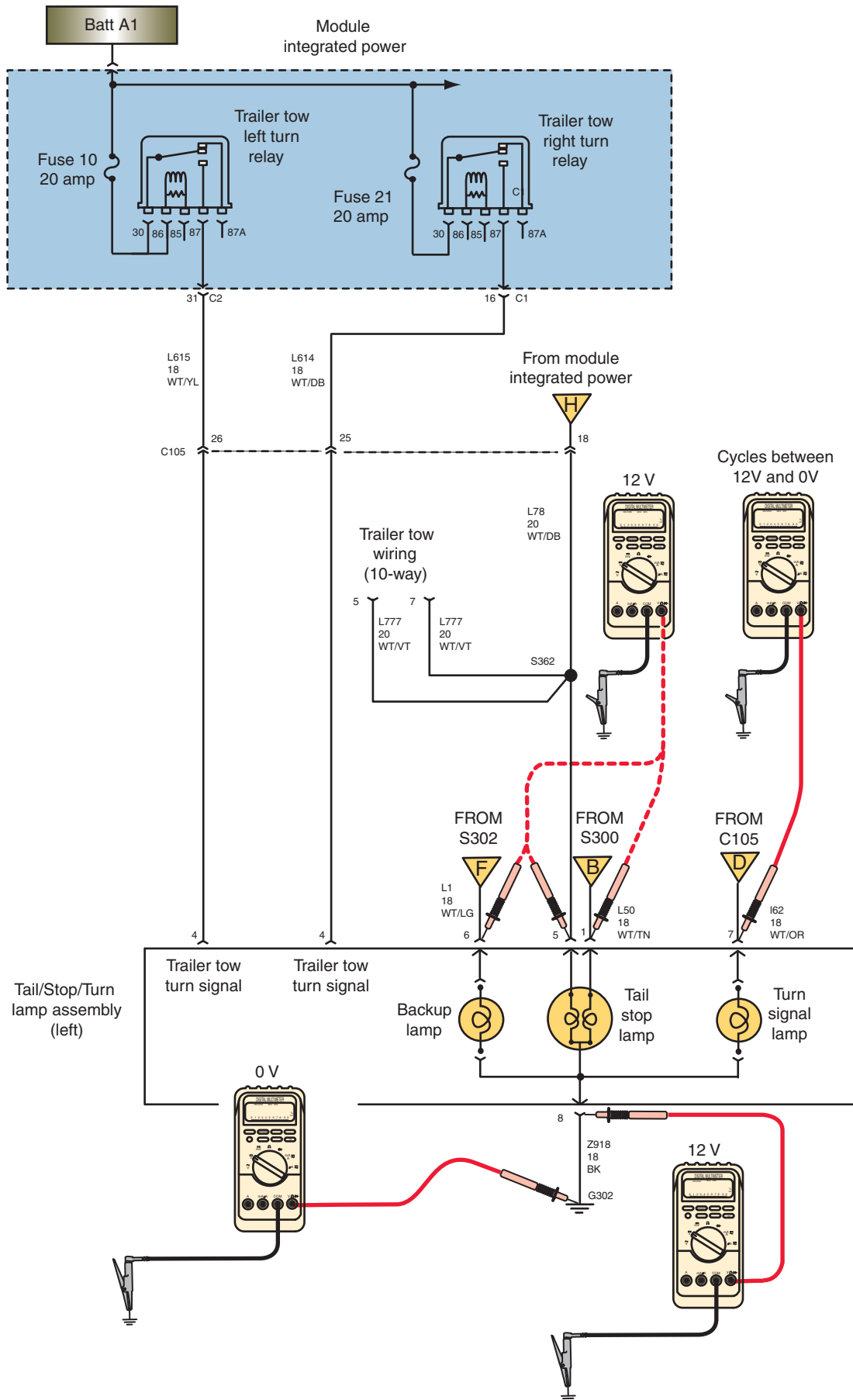
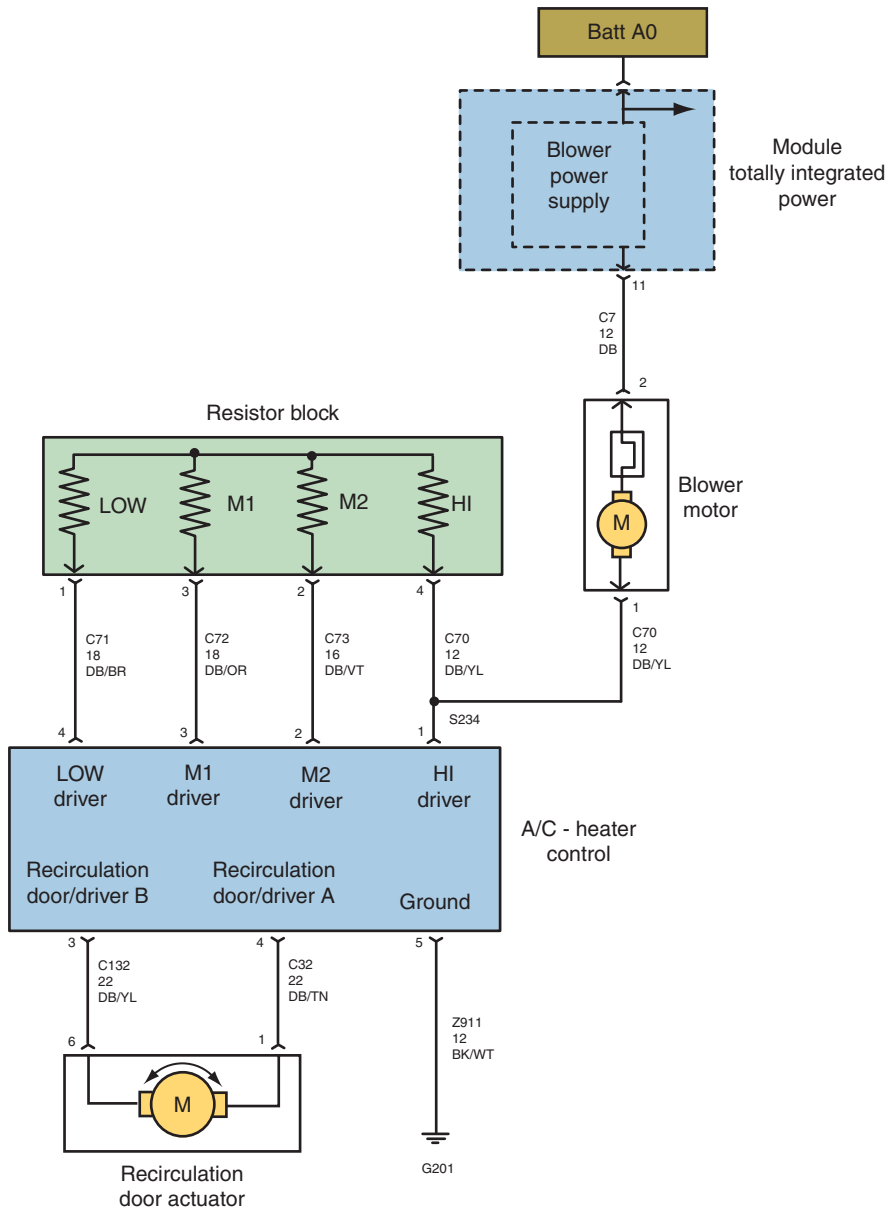


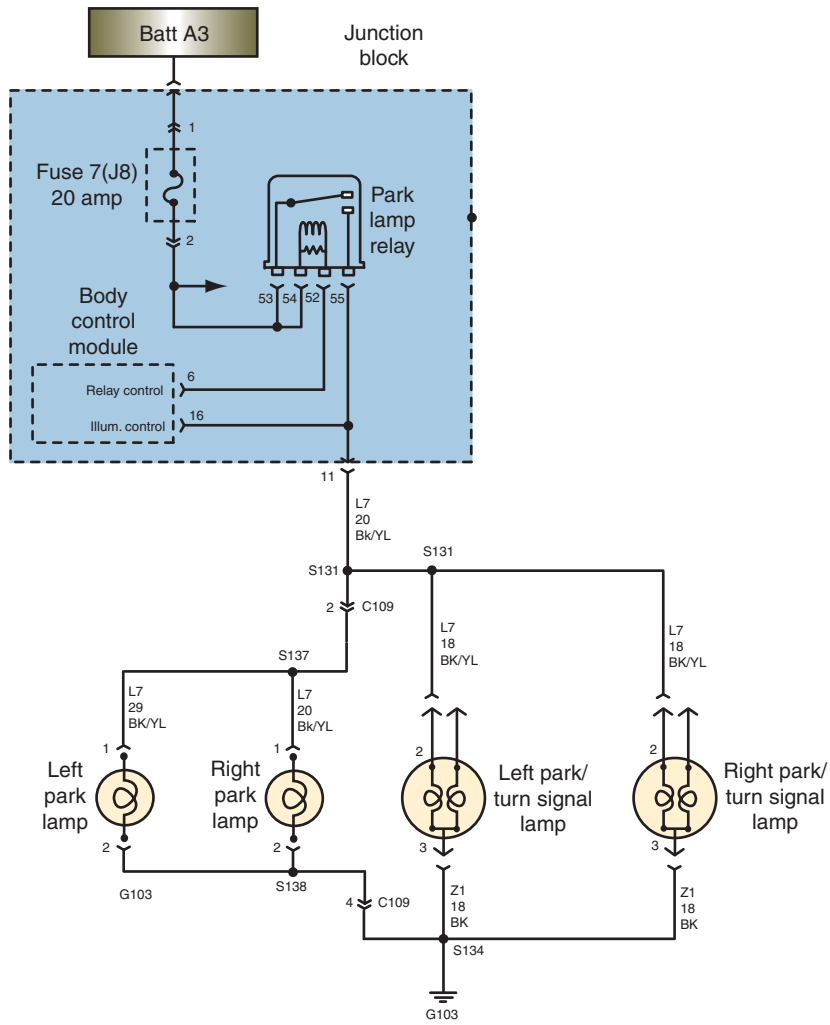
FIGURE 4-33d





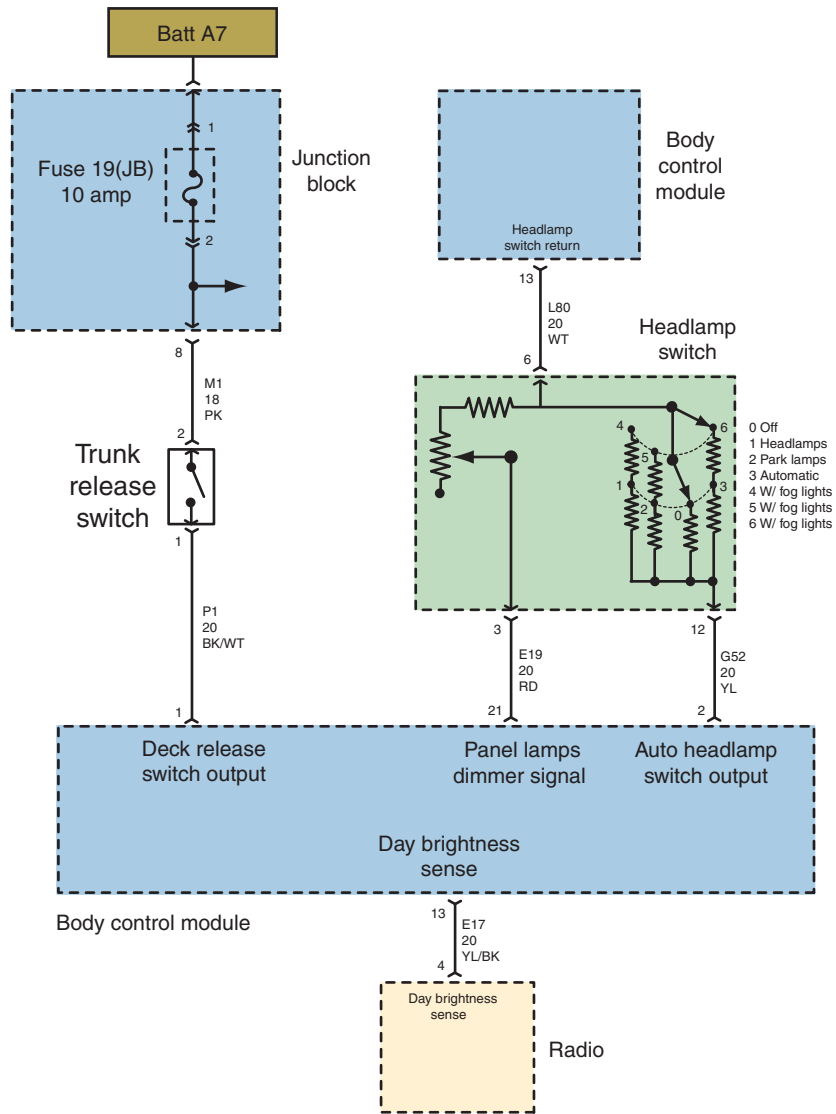
**FIGURE 4-34**

© Delmar/Cengage Learning



**FIGURE 4-35a**

© Delmar/Cengage Learning



**FIGURE 4-35b**

© Delmar/Cengage Learning

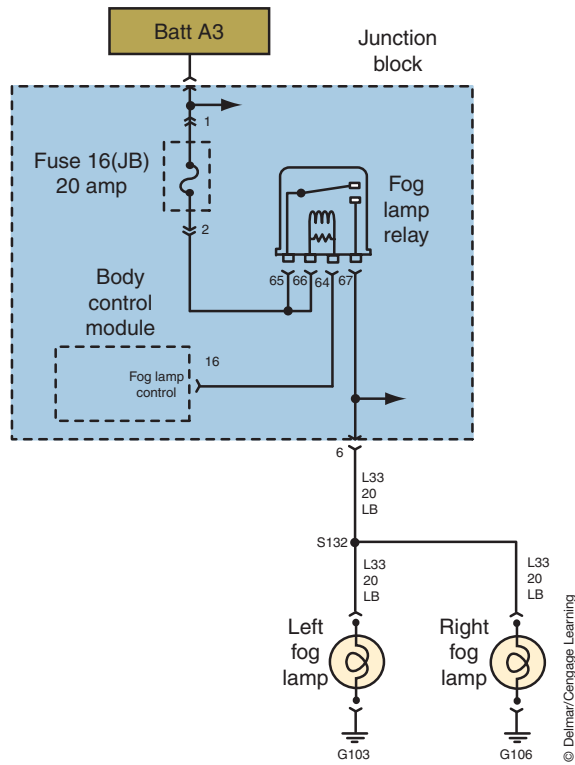


FIGURE 4-35c

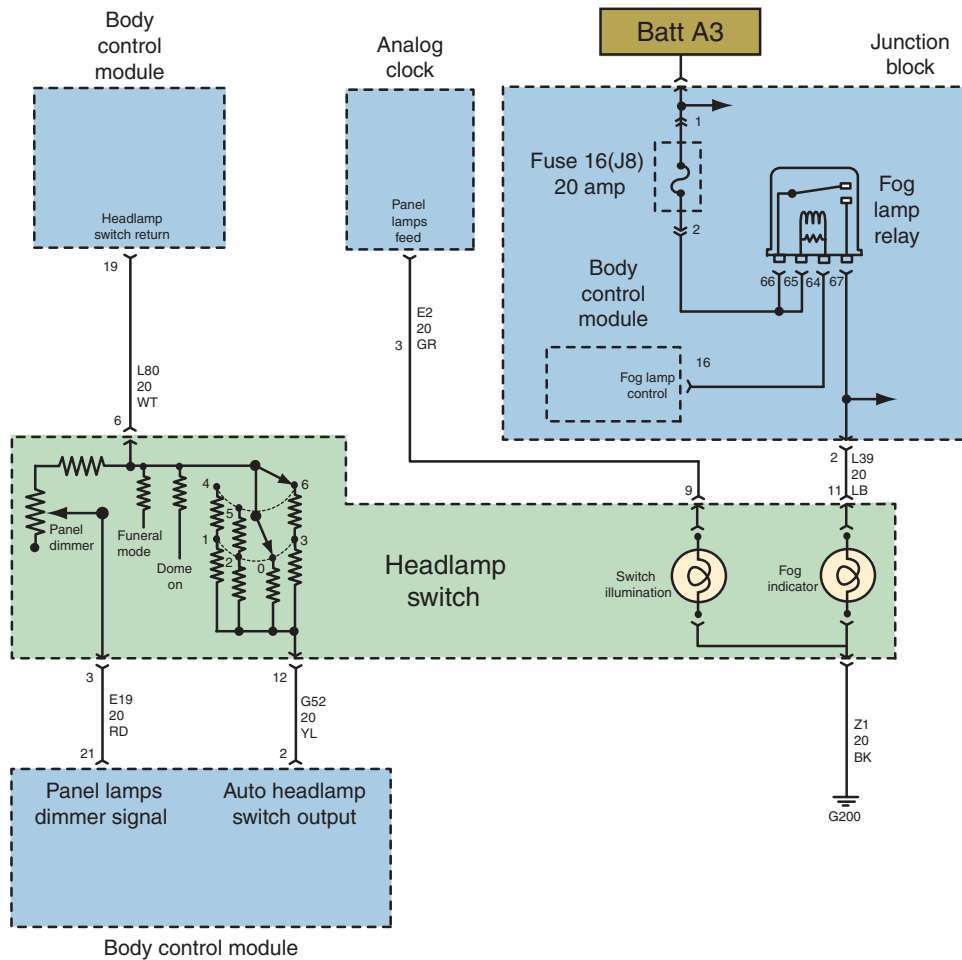


FIGURE 4-35d

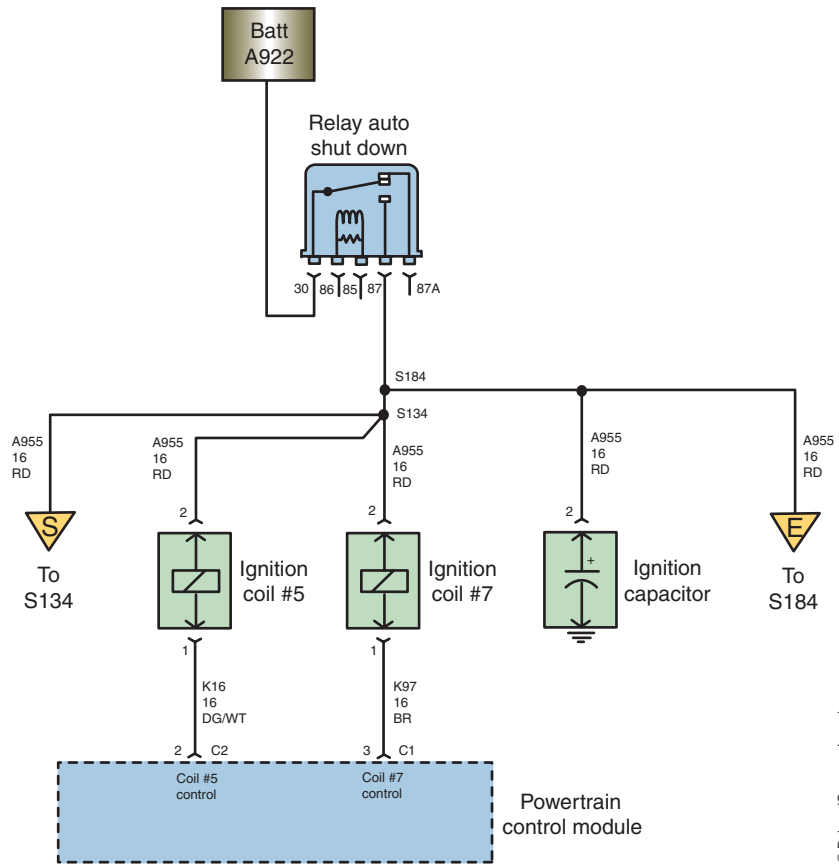


FIGURE 4-36a

© Delmar/Cengage Learning

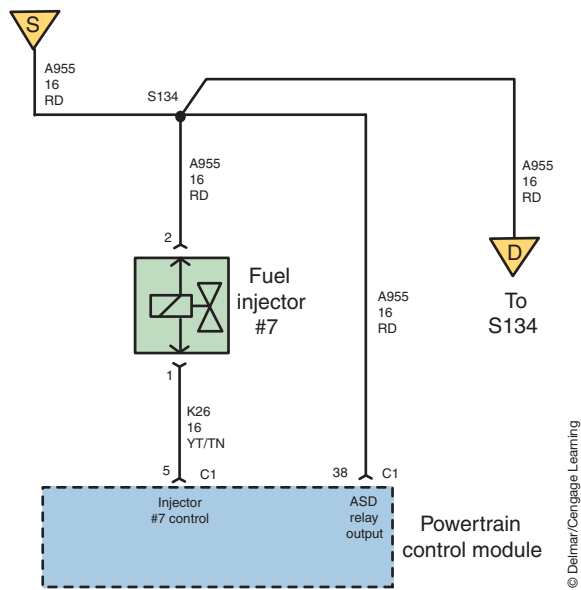


FIGURE 4-36b

© Delmar/Cengage Learning

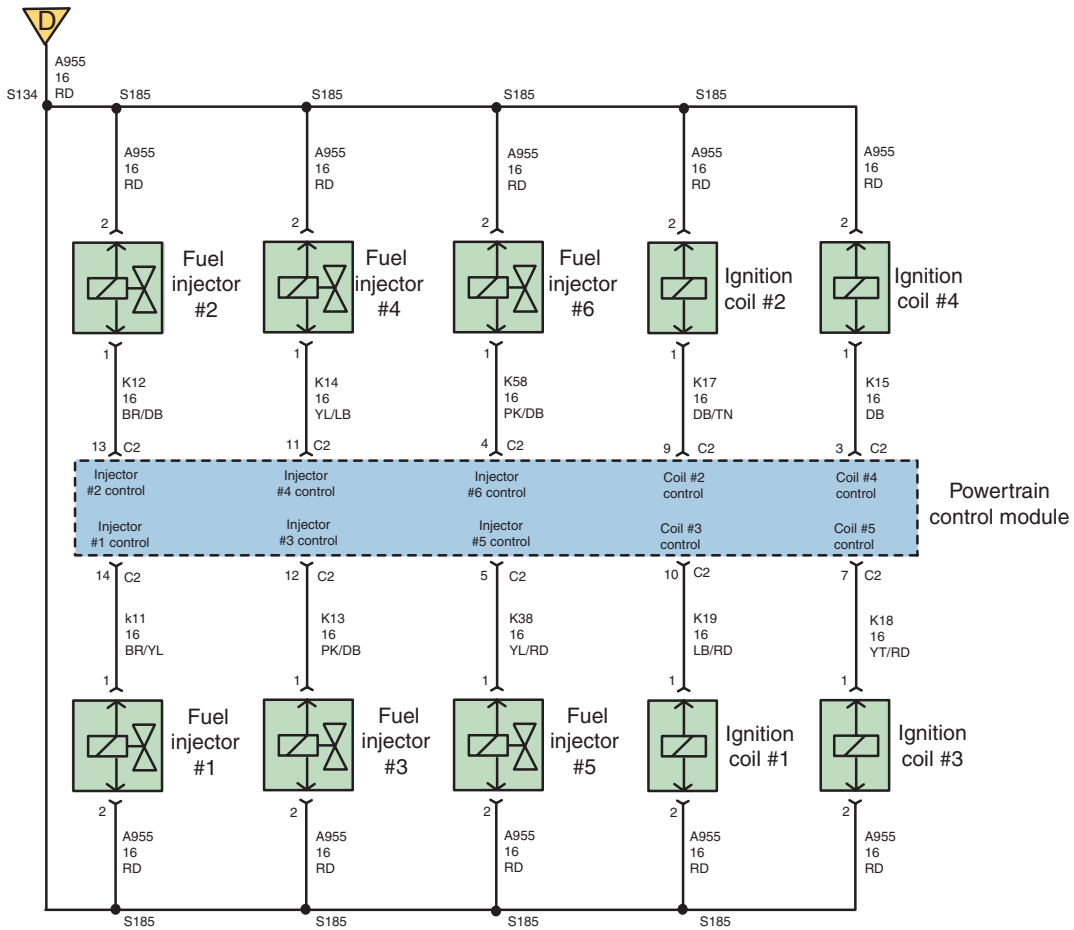


FIGURE 4-36c

© Delmar/Cengage Learning

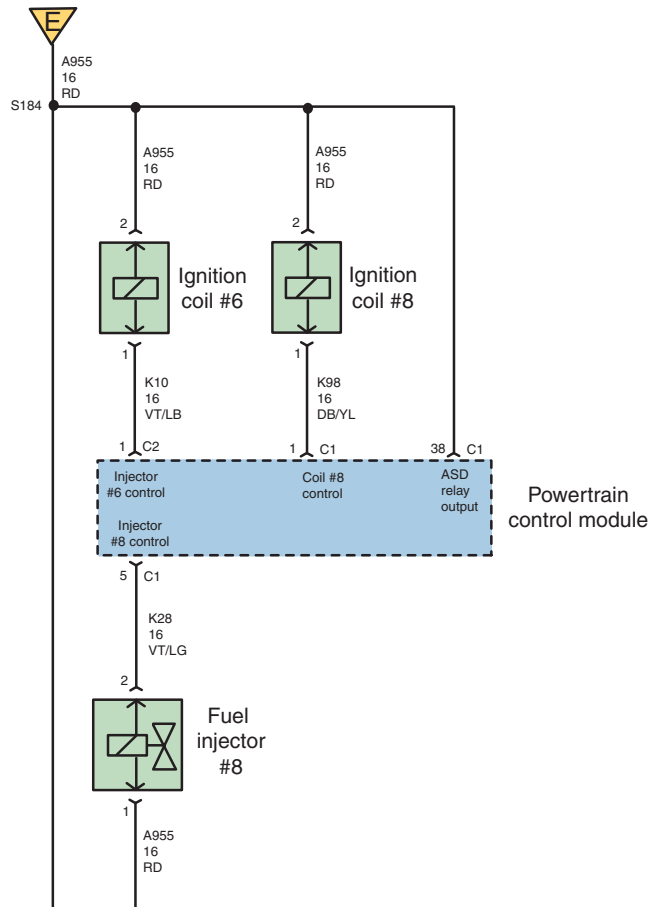


FIGURE 4-36d

© Delmar/Cengage Learning



Name \_\_\_\_\_ Date \_\_\_\_\_

## PART IDENTIFICATION ON A WIRING DIAGRAM

Upon completion of this job sheet, you should be able to locate different parts on a wiring diagram.

### ASE Correlation

This job sheet is related to the ASE Electrical/Electronic System Certification Exam's content area: *General Electrical System Diagnosis*; task: Read and interpret electrical schematic diagrams and symbols.

### Tools and Materials

A wiring diagram in a service manual or from electronic service information system (assigned by the instructor)

### Describe the vehicle being worked on.

Year \_\_\_\_\_ Make \_\_\_\_\_ Model \_\_\_\_\_

VIN \_\_\_\_\_ Engine type and size \_\_\_\_\_

Service information used \_\_\_\_\_

Wiring diagram is found on pages \_\_\_\_\_ to \_\_\_\_\_.

### Procedure

Task Completed \_\_\_\_\_

Study the wiring diagram; then answer the following questions.

1. Are all circuit grounds clearly marked in the wiring diagrams? \_\_\_\_\_

\_\_\_\_\_

2. What is represented by lines that cross each other? \_\_\_\_\_

\_\_\_\_\_

\_\_\_\_\_

3. Are most switches shown in their normally open or normally closed position?

\_\_\_\_\_

4. Do all wires have a color code listed by them? \_\_\_\_\_

5. Is the internal circuitry of all components shown in their schematic drawing?

\_\_\_\_\_

6. List the page and figure numbers (the location) where the following electrical components are shown in the wiring diagram. Then draw the schematical symbol used by this wiring diagram to represent the part.

Component	Location	Drawing
Windshield wiper motor	_____	_____
Dome (courtesy) light	_____	_____
A/C compressor clutch	_____	_____
Turn signal flasher unit	_____	_____
Fuse	_____	_____
Fuel gauge sending unit	_____	_____

7. Attach print out of wiring diagram (if using electronic retrieval system).

Instructor's Response \_\_\_\_\_  
\_\_\_\_\_  
\_\_\_\_\_  
\_\_\_\_\_

Name \_\_\_\_\_ Date \_\_\_\_\_

## USING A COMPONENT LOCATOR

Upon completion of this job sheet, you should be able to identify components and their locations indicated on the wiring diagram that is used for electrical system diagnosis.

### Tools and Materials

Service manual with a component locator section or electronic service information system.

### Describe the vehicle being worked on.

Year \_\_\_\_\_ Make \_\_\_\_\_ Model \_\_\_\_\_

VIN \_\_\_\_\_ Engine type and size \_\_\_\_\_

Service information used \_\_\_\_\_

### Procedure

Using the component locator for the vehicle that has been assigned, the student will find the locations for the taillight, headlight, and stoplight circuits, connectors, connections, plugs, and switches.

\_\_\_\_\_ Task Completed

#### 1. Taillight circuit:

Location of source of power: \_\_\_\_\_

Location of switch: \_\_\_\_\_

Number of connectors: \_\_\_\_\_ ; their location: \_\_\_\_\_

\_\_\_\_\_

\_\_\_\_\_

Location of taillight bulb: \_\_\_\_\_ ; how you get to them: \_\_\_\_\_

\_\_\_\_\_

\_\_\_\_\_

#### 2. Headlight circuit:

Location of source of power: \_\_\_\_\_

Location of switch: \_\_\_\_\_

Number of connectors: \_\_\_\_\_ ; their location: \_\_\_\_\_

\_\_\_\_\_

\_\_\_\_\_

Location of taillight bulb: \_\_\_\_\_ ; how you get to them: \_\_\_\_\_

\_\_\_\_\_

\_\_\_\_\_

Task Completed

**3. Stoplight circuit:**

Location of source of power: \_\_\_\_\_

Location of switch: \_\_\_\_\_

Number of connectors: \_\_\_\_\_ ; their location: \_\_\_\_\_

\_\_\_\_\_

Location of taillight bulb: \_\_\_\_\_ ; how you get to them: \_\_\_\_\_

\_\_\_\_\_

\_\_\_\_\_

**4. Document the path used to locate information in electronic service information system.**

\_\_\_\_\_

\_\_\_\_\_

\_\_\_\_\_

\_\_\_\_\_

\_\_\_\_\_

Instructor's Response \_\_\_\_\_

\_\_\_\_\_

\_\_\_\_\_

\_\_\_\_\_

Name \_\_\_\_\_ Date \_\_\_\_\_

## USING A WIRING DIAGRAM

Upon completion of this job sheet, you should be able to find the power source, ground connection, and controls for electrical circuits using a wiring diagram.

### ASE Correlation

This job sheet is related to the ASE Electrical/Electronic System Certification Exam's content area: *General Electrical System Diagnosis*; task: Read and interpret electrical schematic diagrams and symbols.

### Exercise 1

Using the diagram in Figure 4-37, answer the following (list wire colors):

1. How is the windshield wiper motor circuit powered? \_\_\_\_\_

---



---



---



---

2. How is the circuit grounded?

---



---



---



---

3. How is the circuit controlled?

- a. If it is controlled by a switch, is the switch normally open or closed?
- b. Is the circuit power switched or ground switched?
- c. Is the circuit controlled by a variable resistor?
- d. Is the circuit controlled by a mechanical or vacuum-operated device?

---



---



---



---

4. How is the circuit protected (identify all fuses)?

---



---



---

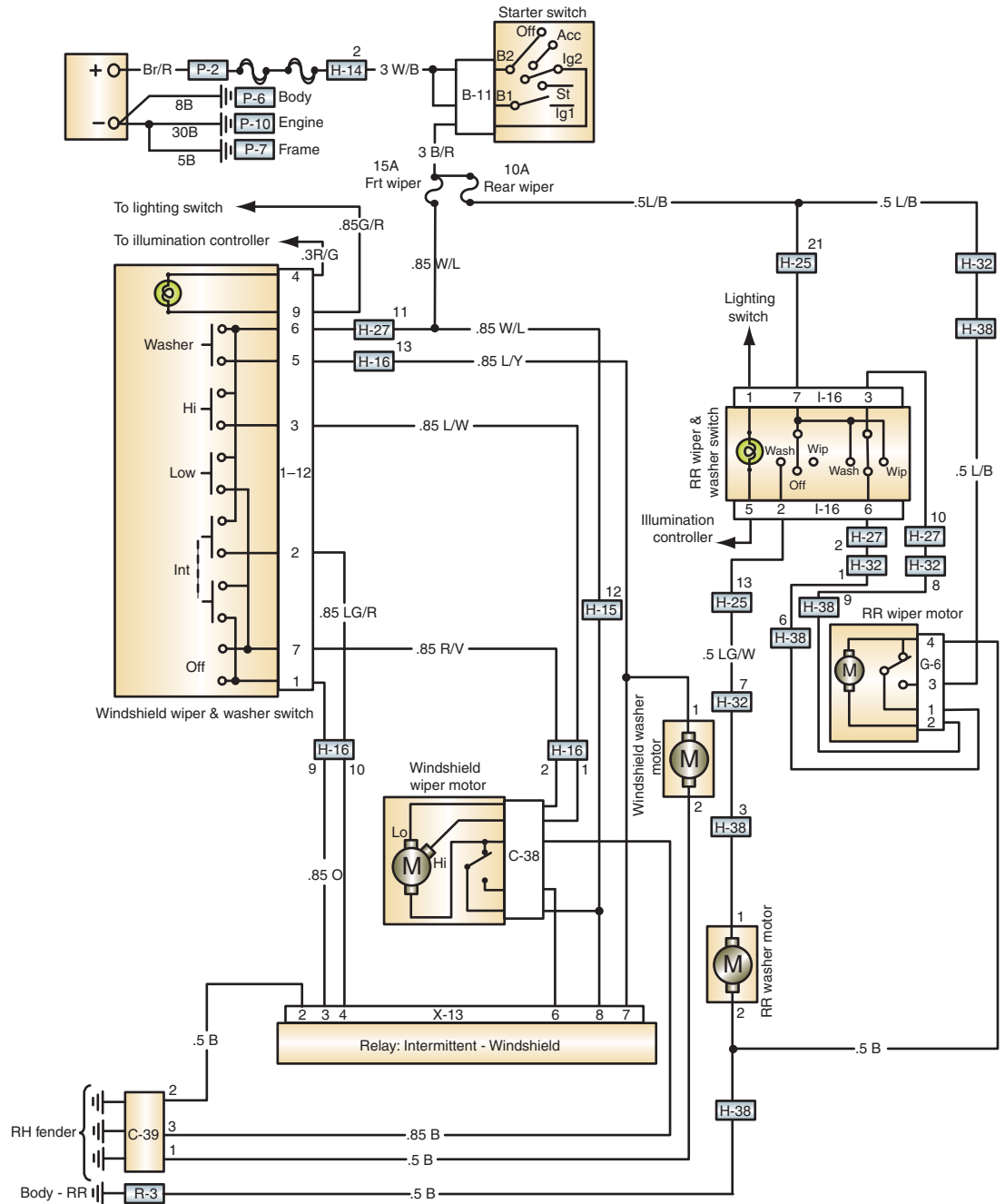


FIGURE 4-37

**Exercise 2**

Using the wiring diagram in Figure 4-38, answer the following:

1. How is the circuit powered? \_\_\_\_\_

---



---



---



---

2. How is the circuit grounded? \_\_\_\_\_

---



---



3. How is the circuit controlled?
  - a. If it is controlled by a switch, is the switch normally open or closed?
  - b. Is the circuit power switched or ground switched?
  - c. Is the circuit controlled by a variable resistor?
  - d. Is the circuit controlled by a mechanical or vacuum-operated device?

4. How is the circuit protected?

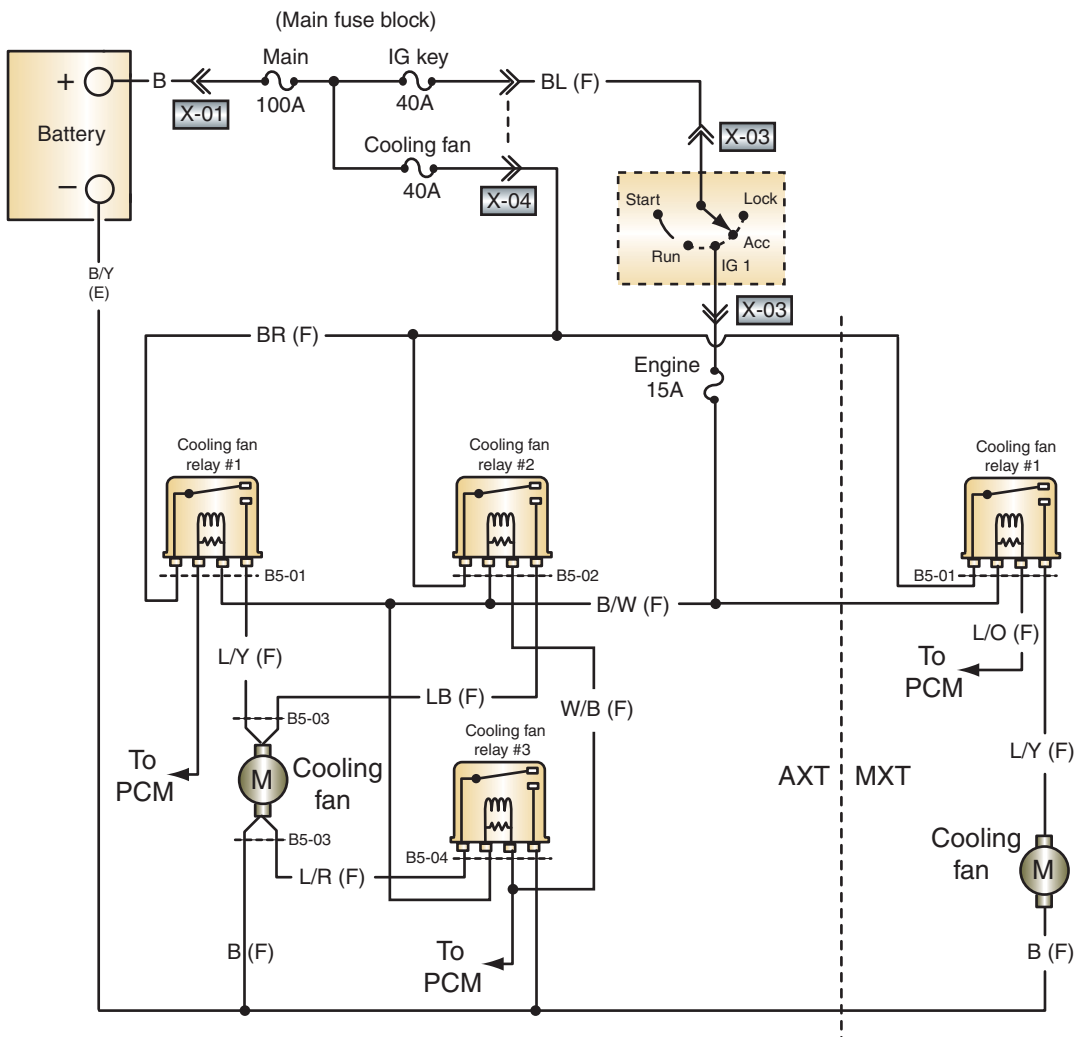


FIGURE 4-38

### Exercise 3

Using the wiring diagram in Figure 4-39, answer the following:

1. How is the circuit powered? \_\_\_\_\_

---

---

---

---

2. How is the circuit grounded?

---

---

---

---

3. How is the circuit controlled?

a. If it is controlled by a switch, is the switch normally open or closed?

b. Is the circuit power switched or ground switched?

c. Is the circuit controlled by a variable resistor?

d. Is the circuit controlled by a mechanical or vacuum-operated device?

---

---

---

---

4. How is the circuit protected?

---

---

---

---

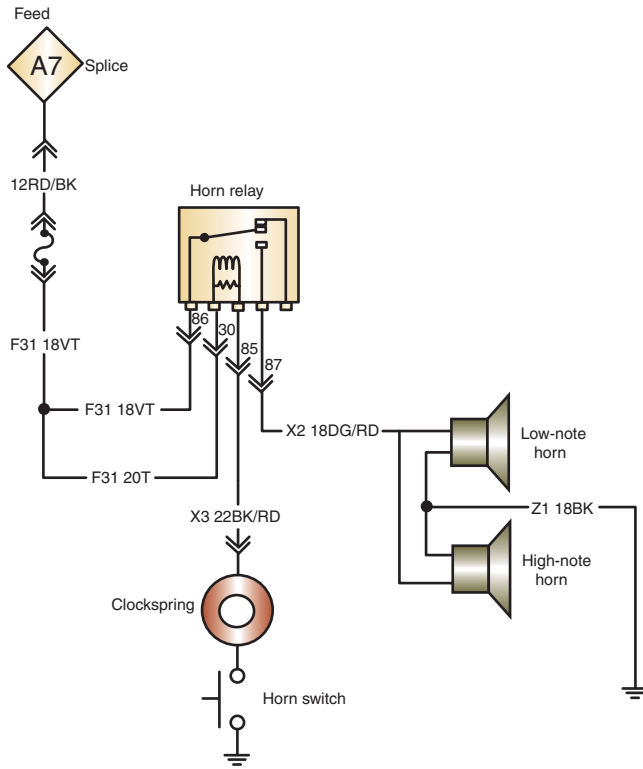


FIGURE 4-39

**Exercise 4**

Using the wiring diagram in Figure 4-40, answer the following:

1. How is the circuit powered? \_\_\_\_\_

---



---



---



---

2. How is the circuit grounded? \_\_\_\_\_

---



---



---



---

3. How is the circuit controlled?

- a. If it is controlled by a switch, is the switch normally open or closed?
- b. Is the circuit power switched or ground switched?
- c. Is the circuit controlled by a variable resistor?
- d. Is the circuit controlled by a mechanical or vacuum-operated device?

---



---

4. How is the circuit protected?

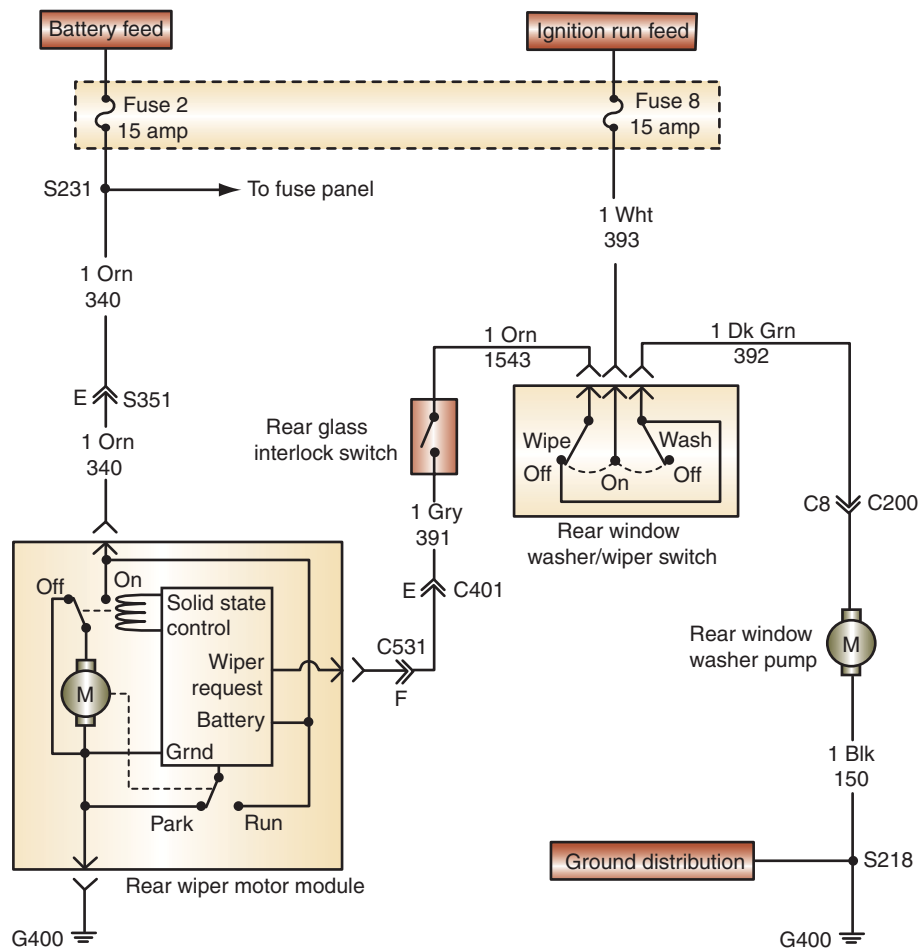


FIGURE 4-40

### Exercise 5

Using the wiring diagram in Figure 4-41, answer the following:

1. How is the circuit powered? \_\_\_\_\_

---

---

---

---

2. How is the circuit grounded?

---

---

---

---

3. How is the circuit controlled?

- a. If it is controlled by a switch, is the switch normally open or closed?
- b. Is the circuit power switched or ground switched?
- c. Is the circuit controlled by a variable resistor?
- d. Is the circuit controlled by a mechanical or vacuum-operated device?

---

---

---

---

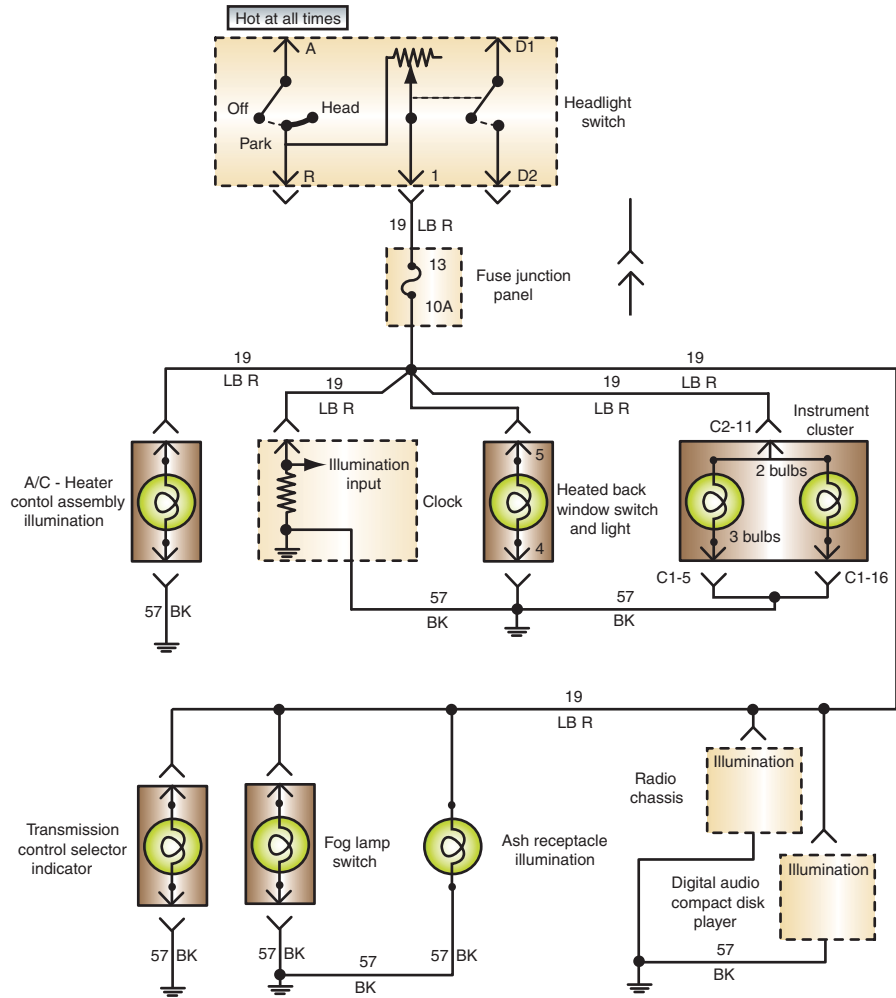
4. How is the circuit protected?

---

---

---

---



**FIGURE 4-41**

Instructor's Response \_\_\_\_\_

\_\_\_\_\_

\_\_\_\_\_

\_\_\_\_\_



Name \_\_\_\_\_ Date \_\_\_\_\_

## SOLDERING COPPER WIRES

Upon completion of this job sheet, you should be able to properly solder two copper wires.

### Tools and Materials

- Two pieces of copper wire
- 100-watt soldering iron
- 60/40 rosin core solder
- Crimping tool
- Splice clip
- Heat shrink tube
- Heating gun
- Safety glasses

### Procedure:

### Task Completed

- |                                                                                                                                                                                                                                                                                                                                                                                                                                                                                                                                                                                                                                                                                                                                                                                                                                                                                                                                                                                                                                                            |                                                                                                                                                                      |
|------------------------------------------------------------------------------------------------------------------------------------------------------------------------------------------------------------------------------------------------------------------------------------------------------------------------------------------------------------------------------------------------------------------------------------------------------------------------------------------------------------------------------------------------------------------------------------------------------------------------------------------------------------------------------------------------------------------------------------------------------------------------------------------------------------------------------------------------------------------------------------------------------------------------------------------------------------------------------------------------------------------------------------------------------------|----------------------------------------------------------------------------------------------------------------------------------------------------------------------|
| <ol style="list-style-type: none"> <li>1. Using the correct size stripper, remove about 1/2 inch (12 mm) of the insulation from both wires. Be careful not to nick or cut any of the wires.</li> <li>2. Select the proper size splice clip to hold the splice.</li> <li>3. Place the correct length and size of heat shrink tube over the wire. Slide the tube far enough away so the wires are not exposed to the heat of the soldering iron.</li> <li>4. Overlap the two splice ends and hold in place with thumb and forefinger. While the wire ends are overlapped, center the splice clip around the wires and crimp into place.</li> <li>5. Heat the splice clip with the soldering iron while applying solder to the opening in the back of the clip. Apply only enough solder to make a good connection. The solder should travel through the wire.</li> <li>6. After the solder cools, slide the heat shrink tube over the splice and heat the tube with the hot air gun until it shrinks around the splice. Do not overheat the tube.</li> </ol> | <input type="checkbox"/><br><input type="checkbox"/><br><input type="checkbox"/><br><input type="checkbox"/><br><input type="checkbox"/><br><input type="checkbox"/> |
|------------------------------------------------------------------------------------------------------------------------------------------------------------------------------------------------------------------------------------------------------------------------------------------------------------------------------------------------------------------------------------------------------------------------------------------------------------------------------------------------------------------------------------------------------------------------------------------------------------------------------------------------------------------------------------------------------------------------------------------------------------------------------------------------------------------------------------------------------------------------------------------------------------------------------------------------------------------------------------------------------------------------------------------------------------|----------------------------------------------------------------------------------------------------------------------------------------------------------------------|

Instructor's Response \_\_\_\_\_

\_\_\_\_\_

\_\_\_\_\_

\_\_\_\_\_

<b>DIAGNOSTIC CHART 4-1</b>	
PROBLEM AREA:	Burned fusible link.
SYMPTOMS:	Several electrical components fail to operate.
POSSIBLE CAUSES:	<ol style="list-style-type: none"> <li>1. Burned or defective fusible link.</li> <li>2. Short to ground in circuit.</li> <li>3. Exclusive circuit current flow.</li> </ol>

<b>DIAGNOSTIC CHART 4-2</b>	
PROBLEM AREA:	Burned, broken, or defective connectors, insulation, or conductors.
SYMPTOMS:	Open or short circuits that prevent component operation.
POSSIBLE CAUSES:	<ol style="list-style-type: none"> <li>1. Corroded wiring.</li> <li>2. Improper or no wire protectors.</li> <li>3. Corroded connectors.</li> <li>4. Damaged conductor</li> <li>5. Damaged connectors</li> </ol>

## BATTERY DIAGNOSIS AND SERVICE



### BASIC TOOLS

Basic mechanic's tool set

Service information

### UPON COMPLETION AND REVIEW OF THIS CHAPTER, YOU SHOULD BE ABLE TO:

- Demonstrate all safety precautions and rules associated with servicing the battery.
- Perform a visual inspection of the battery, cables, and terminals.
- Test a conventional battery's specific gravity.
- Perform an open circuit test and accurately interpret the results.
- Test the capacity of the battery to deliver both current and voltage and to accurately interpret the results.
- Perform a 3-minute charge test to determine if the battery is sulfated.
- Correctly slow and fast charge a battery, in or out of the vehicle.
- Describe the differences between slow and fast charging and determine when either method should be used.
- Jump-start a vehicle by use of a booster battery and jumper cables.
- Perform a battery drain test and accurately determine the causes of battery drains.
- Perform a battery leakage test and determine the needed corrections.
- Do a battery terminal test and accurately interpret the results.
- Remove, clean, and reinstall the battery properly.
- Determine the cause of HV battery system failures.
- Measure HV battery module voltages with a DMM.

### INTRODUCTION

A discharged or weak battery can affect more than just the starting of the engine. The battery is the heart of the electrical system of the vehicle. It is important that it is not overlooked when servicing most electrical problems. The function of the battery is to:

1. Operate the starting motor, ignition system, electronic fuel injection, and other electrical devices for the engine during cranking and starting.
2. Supply all the electrical power for the vehicle accessories whenever the engine is not running or at low idle.
3. Supplement current for a limited time whenever electrical demands exceed charging system output.
4. Act as a stabilizer of voltage for the entire automotive electrical system.
5. Store energy for extended periods of time.
6. Keep power to computer memory.

Because of its importance, the battery should be checked whenever the vehicle is brought into the shop for service. A battery test series will show the state of charge and output voltage of the battery, which determine if it is good, is in need of recharging, or must be replaced.

**Classroom  
Manual**

Chapter 5, page 108



© Delmar/Cengage Learning

**FIGURE 5-1** A Sun VAT-40 battery, starting, and charging system tester.



© Delmar/Cengage Learning

**FIGURE 5-2** A computer-based generator, regulator, battery, and starter tester.

There are many different manufacturers of battery test equipment. For years, the most popular tester was the Sun Electrical Corporation's VAT-40 (Figure 5-1). Most modern testers are computer based and conduct the tests automatically after a particular test is selected (Figure 5-2). Always follow the procedures given by the tester's manufacturer.

## GENERAL PRECAUTIONS

Before attempting to do any type of work on or around the battery, the technician must be aware of certain precautions. To avoid personal injury or property damage, take the following precautions:

1. Battery acid is very corrosive. Do not allow it to come in contact with skin, eyes, or clothing. If battery acid gets into your eyes, rinse them thoroughly with clean water and receive immediate medical attention. If battery acid comes in contact with skin, wash with clean water. Baking soda added to the water will help to neutralize the acid. If the acid is swallowed, drink large quantities of water or milk followed by milk of magnesia and a beaten egg or vegetable oil.
2. When making connections to a battery, be careful to observe polarity, positive to positive and negative to negative.
3. When disconnecting battery cables, always disconnect the negative (ground) cable first.
4. When connecting battery cables, always connect the negative cable last.
5. Avoid any arcing or open flames near a battery. The vapors produced by the battery cycling are very explosive. Do not smoke around a battery.

6. Follow manufacturer's instructions when charging a battery. Charge the battery in a well-ventilated area. Do not connect or disconnect the charger leads while the charger is turned on.
7. Do not add additional electrolyte to the battery if it is low. Add only distilled water.
8. Do not wear any jewelry or watches while servicing the battery. These items are excellent conductors of electricity. They can cause severe burns if current flows through them by accidental contact with the battery positive terminal and ground.
9. Never lay tools across the battery. They may come into contact with both terminals, shorting out the battery and causing it to explode.
10. Wear safety glasses or face shield when servicing the battery.
11. If the battery's electrolyte is frozen, allow it to defrost before doing any service or testing of the battery. While it is defrosting, look for leaks in the case. Leakage means the battery is cracked and should be replaced.

## BATTERY INSPECTION

Before performing any electrical tests, the battery should be inspected, along with the cables and terminals. The complete visual inspection of the battery should include the following items:

1. Battery date code: This provides information as to the age of the battery (Figure 5-3).
2. Condition of battery case: Check for dirt, grease, and electrolyte condensation. Any of these contaminants can create an electrical path between the terminals and cause the battery to drain. Also check for damaged or missing vent caps and cracks in the case. A cracked or buckled case could be caused by excessive tightening of the holddown fixture, excessive under-hood temperatures, buckled plates from extended undercharged conditions, freezing, or excessive charge rate.
3. Electrolyte level, color, and odor: If necessary, add distilled water to fill to 1/2 inch (12 mm) above the top of the plates. After adding water, charge the battery before any tests are performed. Discoloration of electrolyte and the presence of a "rotten egg" odor indicate an excessive charge rate, excessive deep cycling, impurities in the electrolyte solution, or an old battery.

**Classroom  
Manual**

Chapter 5, page 110



### SPECIAL TOOLS

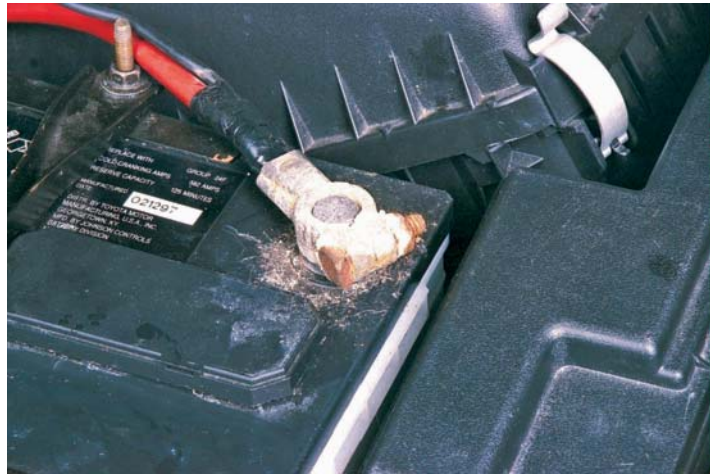
Fender covers  
Safety glasses  
Battery filler bottle



© Delmar/Cengage Learning

**FIGURE 5-3** The battery sticker will usually have the date the battery was sold, plus additional information.





© Delmar/Cengage Learning

**FIGURE 5-4** Inspect the condition of the battery cables and terminals.

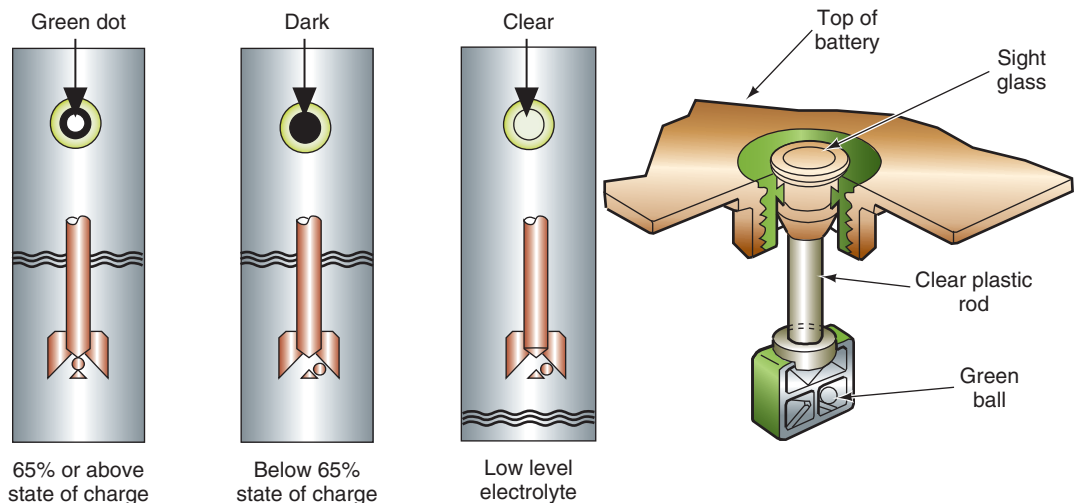


**SERVICE TIP:**

Grid growth can cause the battery plate to short out the cell. If there is normal electrolyte level in all cells but one, that cell is probably shorted and the electrolyte has been converted to hydrogen gas.

4. Condition of battery cables and terminals: Check for corrosion, broken clamps, frayed cables, and loose terminals (Figure 5-4). These conditions result in voltage drop between the battery terminal and the end of the cable. The sulfuric acid that vents out with the battery gases attacks the battery terminals and battery cables. As the sulfuric acid reacts with the lead and copper, deposits of lead sulfate and copper sulfate are created. These deposits are resistive to electron flow and limit the amount of current that can be supplied to the electrical and starting systems. If the deposits are bad enough, the resistance can increase to a level that prevents the starter from cranking the engine.
5. Battery abuse: This includes the use of bungee cords and  $2 \times 4$ s for holddown fixtures, too small of a battery rating for the application, and obvious neglect to periodic maintenance. In addition, inspect the terminals for indications that they have been hit by a hammer and for improper cable removal procedures. Finally, check for proper cable length.
6. Battery tray and holddown fixture: Check for proper tightness. Also check for signs of acid corrosion of the tray and holddown unit. Replace as needed.
7. If the battery has a built-in hydrometer, check its color indicator (Figure 5-5).

One common cause of early battery failure is overcharging. If the charging system is supplying a voltage level over 15.5 volts, the plates may become warped. Warping of the



© Delmar/Cengage Learning

**FIGURE 5-5** Built-in hydrometer used to indicate a battery's state of charge.



plates results from the excess heat that is generated as a result of overcharging. Overcharging also causes the active material to disintegrate and shed off of the plates.

If the charging system does not produce enough current to keep the battery charged, the lead sulfate can become crystallized on the plates. If this happens, the sulfate is difficult to remove and the battery will resist recharging. The recharging process converts the sulfate on the plates. If there is an undercharging condition, the sulfate is not converted and it will harden on the plates.

Vibration is another common reason for battery failure. If the battery is not secure, the plates will shed the active material as a result of excessive vibration. If enough material is shed, the sediment at the bottom of the battery can create an electrical connection between the plates. The shorted cell will not produce voltage, resulting in a battery that will have only 10.5 volts across the terminals. With this reduced amount of voltage, the starter usually will not be capable of starting the engine. To prevent this problem, make sure that proper hold-down fixtures are used.

During normal battery operation, the active materials on the plates will shed. The negative plate also becomes soft. Both of these events will reduce the effectiveness of the battery.

## CHARGING THE BATTERY



**WARNING:** There are many safety precautions associated with charging the battery. The hydrogen gases produced by a charging battery are very explosive. Exploding batteries are responsible for over 15,000 injuries per year that are severe enough to require hospital treatment. Keep sparks, flames, and lighted cigarettes away from the battery. Also, do not use the battery to lay tools on. They may short across the terminals and result in the battery exploding. Always wear eye protection and proper clothing when working near the battery. Also, most jewelry is an excellent conductor of electricity. Do not wear any jewelry when performing work on or near the battery. Do not remove the vent caps while charging. Do not connect or disconnect the charger leads while the charger is turned on.

To **charge** the battery means to pass an electric current through the battery in an opposite direction than during discharge. If the battery needs to be recharged, the safest method is to remove the battery from the vehicle. The battery can be charged in the vehicle, however. If the battery is to be charged in the vehicle, it is important to protect any vehicle computers by removing the negative battery cable.

When connecting the charger to the battery, make sure the charger is turned off. Connect the cable leads to the battery terminals, observing polarity. Attempting to charge the battery while the cables are reversed will result in battery damage. For this reason, many battery chargers have a warning system to alert the technician that the cables are connected in reverse polarity. Rotate the clamps slightly on the terminals to assure a good connection.

Depending on the requirements and amount of time available, the battery can be either slow or fast charged. Each method of charging has its advantages and disadvantages.

### Slow Charging

**Slow charging** means the charge rate is between 3 and 15 amperes for a long period of time. Slow charging the battery has two advantages: It is the only way to restore the battery to a fully charged state and it minimizes the chances of overcharging the battery. Slow charging

The sulfate that is not converted back to  $H_2SO_4$  hardens on the plates. This results in battery sulfation, which permanently damages the battery.

### Classroom Manual

Chapter 5, page 113



### SPECIAL TOOLS

Safety glasses  
Battery charger  
Voltmeter  
Fender covers



### CAUTION:

Before charging a battery that has been in cold weather, check the electrolyte for ice crystals. **Do not attempt to charge a frozen battery.** Forcing current through a frozen battery may cause it to explode. Allow it to warm at room temperature for a few hours before charging.

**CAUTION:**

If the battery is to be removed from the vehicle, disconnect the negative battery cable first. Lift the battery out with a carrying tool (Figure 5-6).

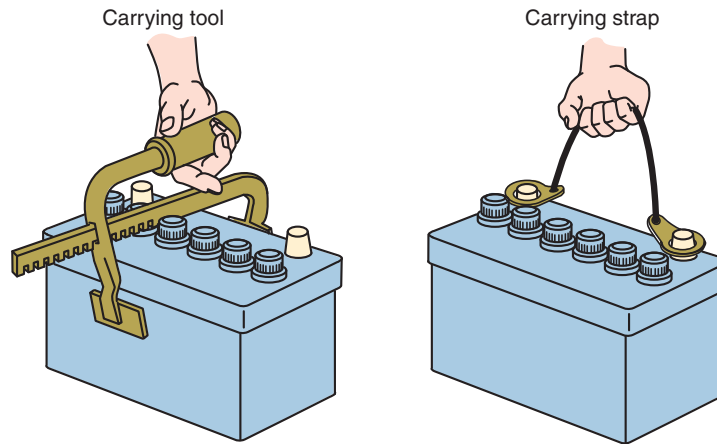
Slow charging is often referred to as “trickle charging.”

**CAUTION:**

Fast charging the battery requires that the battery be monitored at all times and the charging time must be controlled. Do not fast charge a battery for longer than 2 hours. Excessive fast charging can damage the battery. Do not allow the voltage of a 12-volt battery to exceed 15.5 volts. Also, don't allow the temperature to rise above 125°F.

**SERVICE TIP:**

If a battery is severely discharged and will not take a slow charge, connect a good battery in parallel (with jumper cables). Fast charge for 30 minutes, then disconnect the good battery and slow charge the discharged battery.



© Delmar/Cengage Learning

**FIGURE 5-6** Always use a battery carrier to lift the battery.

the battery causes the lead sulfate on the plates to convert to lead peroxide and sponge lead throughout the thickness of the plate.

## Fast Charging

**Fast charging** uses a high current for a short period of time to boost the battery. Fast charging the battery will bring the state of charge up high enough to crank the engine. However, fast charging is unable to recharge the battery as effectively as slow charging. Fast charging the battery converts only the lead sulfate on the outside of the plates. The conversion does not go through the plates. After the battery has been fast charged to a point that it will crank the engine, it should then be slow charged to a full state.

## Charge Rate

The **charge rate** is the speed at which the battery can safely be recharged at a set amperage. The charge rate required to recharge a battery depends on several factors:

1. Battery capacity. High-capacity batteries require longer charging time.
2. State of charge.
3. Battery temperature.
4. Battery condition.

Slow charging is the easiest on the battery. However, slow charging requires a long period of time. The basic rule of thumb for slow charging the battery is 1 ampere for each positive plate in one cell.

Slow charging of the battery may not always be practical due to the time involved. In these cases, fast charging is the only alternative. To determine the charging time for a full charge based on charge rate amperes, use the illustration (Table 5-1).

An alternative method is to connect a voltmeter across the battery terminals while it is charging. If the voltmeter reads fewer than 15 volts, the charging rate is low enough. If the voltmeter reads over 15 volts, reduce the charging rate until voltage reads below 15 volts. Keeping the voltage at 15 volts will ensure the quickest charge and a safe rate for the battery.

**There are three methods of determining if the battery is fully charged:**

1. Specific gravity holds at 1.264 or higher after the battery is stabilized.
2. An open circuit voltage test indicates 12.68 or higher after the battery has been stabilized.
3. The ammeter on the battery charger falls to approximately 3 amperes or less and remains at that level for 1 hour.

**TABLE 5-1** Table showing the rate and time of charging a battery. Electrolyte temperatures should not exceed 125°F (51.7°C) during charging.

Open Circuit Voltage	Battery Specific Gravity	State of Charge	Charging time of Full Charge at 80° F (267° C)					
			at 60 amps	at 50 amps	at 40 amps	at 30 amps	at 20 amps	at 10 amps
12.6	1.265	100%	Full Charge					
12.4	1.225	75%	15 min.	20 min.	27 min.	35 min.	48 min.	90 min.
12.2	1.190	50%	35 min.	45 min.	55 min.	75 min.	95 min.	180 min.
12.0	1.155	25%	50 min.	65 min.	85 min.	115 min.	145 min.	280 min.
11.8	1.120	0%	65 min.	85 min.	110 min.	150 min.	150 min.	370 min.

## Recharging Gel Cell Batteries

Most gel cell batteries will accept being recharged very well. This is due, in part, to their low internal resistance. However, overcharging is very harmful to gel cell batteries. Since gel cell batteries use a special sealing design, overcharging will dry out the electrolyte by forcing the oxygen and hydrogen from the battery through the safety valves.

If a battery is continually undercharged, a layer of sulfate will build up on the positive plate. The sulfate then acts to resist the flow of electrons. This may also result in plate shedding, reducing performance and shorting battery life.

When recharging the gel cell battery, it is critical that the charger being used will properly limit the voltage to no more than 14.1 volts and no less than 13.8 volts at 68°F (20°C). This requires special charging equipment designed to recharge gel cell batteries. Older-type battery chargers use higher voltages and charging rates and usually cannot be used to recharge gel cell batteries. A gel cell battery that is charged at too high of a voltage may experience shorter battery life because of damage resulting from the battery temperature increasing to over 100°F (37.8°C).

Most modern battery chargers are compatible with gel cell-type batteries and have a switch to cycle between flooded and gel batteries. Be sure to check the documentation supplied with the charger you are using to recharge a gel cell battery.

**Classroom Manual**

Chapter 5, page 118

## MAINTAINING MEMORY FUNCTIONS

Today's vehicles are equipped with several computer control modules that use memories to store values and presets. These include radio station selection, memory seat positions, transmission shift schedule learning, adaptive fuel strategies, and so on. These memories require battery voltage to be maintained and will reset if the battery is disconnected. If the battery is disconnected to perform battery tests, battery service, or to be charged, then a memory keeper discussed in Chapter 2 of this text can be used to maintain the memories. However, if the battery is to be disconnected to perform electrical circuit tests or repairs, then the memory keeper should not be used and the memory function should be restored.

## BATTERY TEST SERIES

When the battery and cables have been completely inspected and any problems have been corrected, the battery is ready to be tested further. For the tests to be accurate, the battery must be fully charged.



### SPECIAL TOOLS

Safety glasses  
Voltmeter  
Terminal pliers  
Terminal puller  
Terminal and  
clamp cleaner  
Fender covers

## Battery Terminal Test

The **battery terminal test** checks for poor electrical connections between the battery cables and terminals. Use a voltmeter to measure voltage drop across the cables and terminals. It is good practice to perform the battery terminal test anytime the battery cable is disconnected and reconnected to the terminals. By performing this test, comebacks, due to loose or faulty connections, can be reduced.

The battery must be fully charged to perform this test. Connect the negative voltmeter test lead to the cable clamp and connect the positive meter lead to the battery terminal (Figure 5-7). Follow the vehicle manufacturer's recommend method to disable the ignition system to prevent the vehicle from starting. This may be done by removing the ignition coil secondary wire from the distributor cap and putting it to ground. Many systems require the removal of the fuel pump or electronic fuel injection (EFI) relay in order to prevent the engine from starting.

Crank the engine and observe the voltmeter reading. If the voltmeter shows over 0.3 volt, there is a high resistance at the cable connection. Remove the battery cable using the clamp puller (Figure 5-8). Clean the cable ends and battery terminals (Figure 5-9).



FIGURE 5-7 Voltmeter connections for the battery terminal test.



FIGURE 5-8 Use battery clamp pullers to remove the cable end from the terminal. Do not pry the clamp off.



FIGURE 5-9 A terminal cleaning tool is used to clean the battery's terminals and the cable's clamps



## Battery Leakage Test

Battery drain can be caused by a dirty battery. The dirt can actually allow current flow over the battery case. This current flow can drain a battery as quickly as leaving a light on. A **battery leakage test** is conducted to see if current is flowing across the battery case. To perform a battery leakage test, set a voltmeter to a low DC volt scale. Connect the negative test lead to the negative terminal of the battery. Move the red test lead across the top and sides of the battery case (Figure 5-10). If the meter reads voltage, a current path from the negative terminal of the battery to its positive terminal is being completed through the dirt. Keep in mind that you should not measure voltage anywhere on the case of the battery. If voltage is present, remove the battery. Then use a baking soda and water mixture to clean the case of the battery. When cleaning the battery, don't allow the baking soda and water solution to enter its cells. After the case is clean, rinse it off with clean water.

## State of Charge Test

Measuring the **state of charge** is a check of the battery's electrolyte and plates. The state of charge test uses the measurement of the specific gravity to determine the charge of the battery.

**To use the hydrometer to test the battery's state of charge:**

1. Remove all battery vent caps.
2. Check the electrolyte level. It must be high enough to withdraw the correct amount of solution into the **hydrometer**. A hydrometer measures the specific gravity of a liquid (Figure 5-11).
3. Squeeze the bulb and place the pickup tube into the electrolyte of a cell.
4. Slowly release the bulb. Draw in enough solution until the float is freely suspended in the barrel. Hold the hydrometer in a vertical position.

### Classroom Manual

Chapter 5, page 116



### SPECIAL TOOLS

Voltmeter  
Fender covers  
Safety glasses

### Classroom Manual

Chapter 5, page 113



### SPECIAL TOOLS

Hydrometer

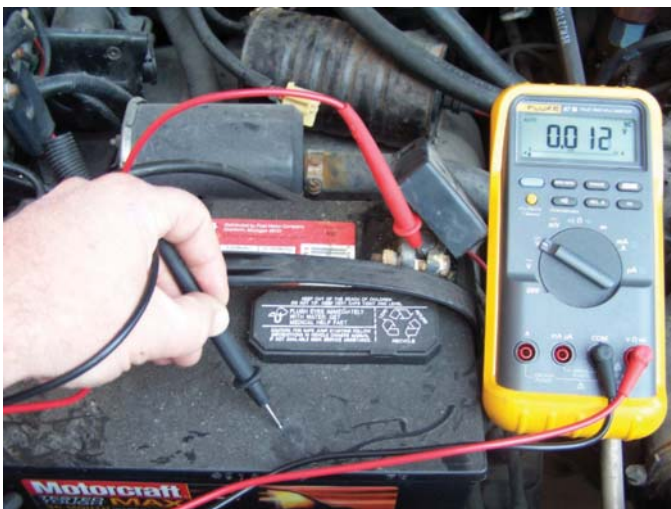


FIGURE 5-10 Using a voltmeter to performing the battery leakage test.

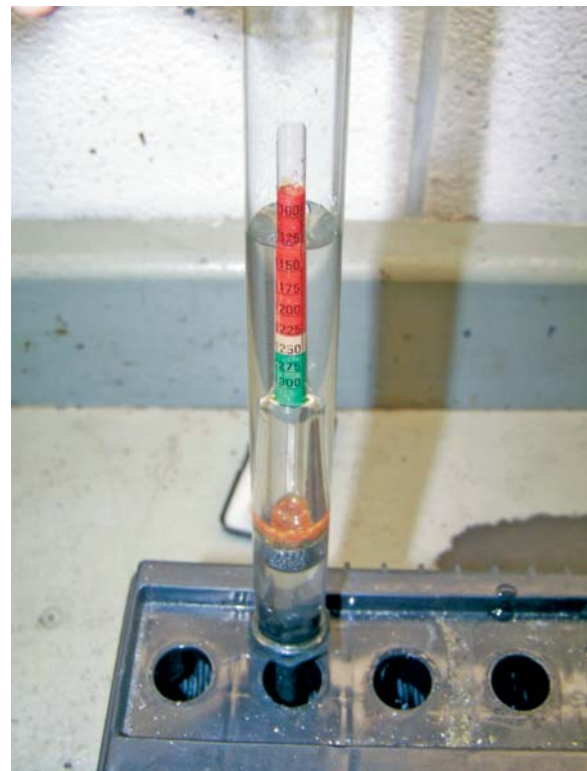
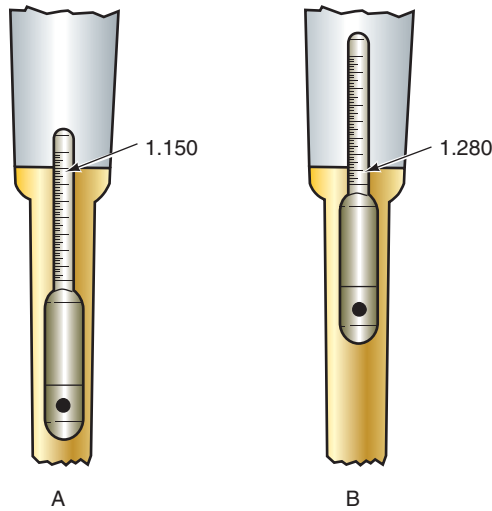


FIGURE 5-11 A temperature correction hydrometer is used to measure the specific gravity of the electrolyte solution, providing an indication of the battery's state of charge.

© Delmar/Cengage Learning



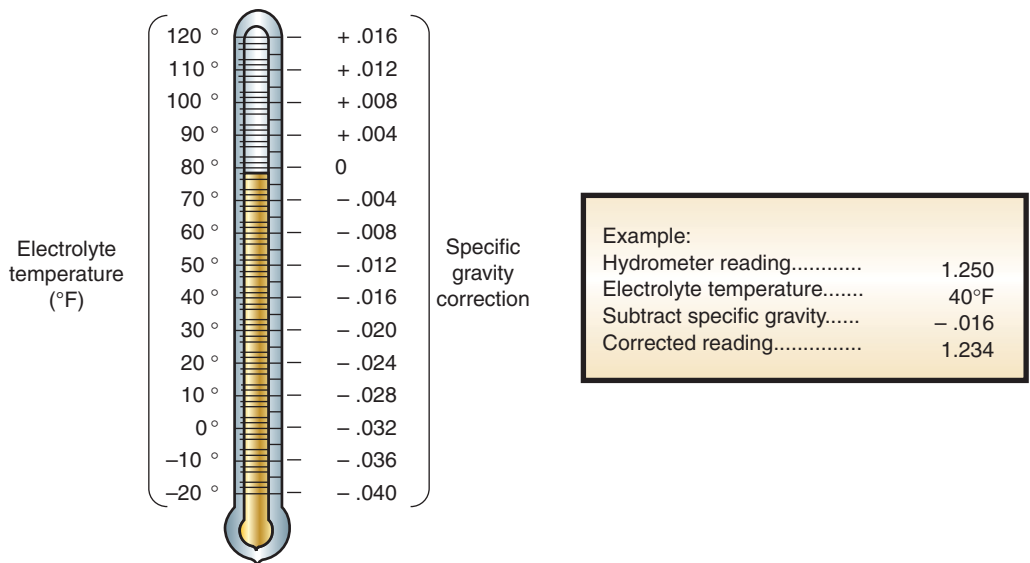
**FIGURE 5-12** The specific gravity of the electrolyte is read at the point where the electrolyte intersects the float. (A) Shows a low reading, (B) shows a high reading.

The float rises and the specific gravity is read where the float scale intersects the top of the solution (Figure 5-12). The reading must also be corrected by compensating for temperatures (Figure 5-13).

If the electrolyte is too low to perform the test, add distilled water to the cell. Do not take hydrometer readings until the water and electrolyte have been mixed by charging the battery.

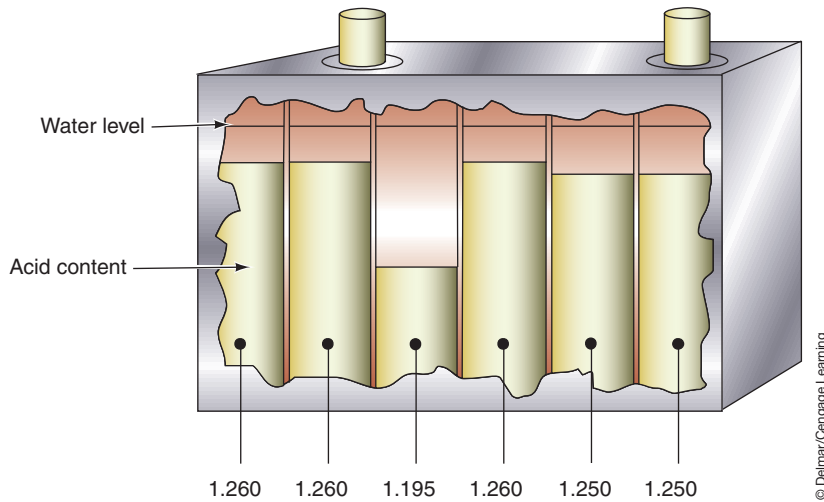
**Test Results.** As a battery becomes discharged, its electrolyte has a larger percentage of water. Thus, a discharged battery's electrolyte will have a lower specific gravity number than that of a fully charged battery.

A fully charged battery will have a hydrometer reading near 1.265. Remember, the specific gravity is also influenced by the temperature of the electrolyte and the readings must be corrected to the temperature. If the corrected hydrometer reading is below 1.265, the battery needs recharging or it may be defective.



**FIGURE 5-13** Correct the specific gravity reading according to the temperature of the electrolyte.





**FIGURE 5-14** A defective cell can be determined by the specific gravity readings.

A defective battery can be determined with a hydrometer by checking every cell. If the specific gravity has a 0.050-point variation between the highest and lowest cell readings, the battery is defective (Figure 5-14). When all the cells have an equal gravity, even if all are low, the battery can usually be regenerated by recharging.

Specific gravity tests should not be used as the sole determinant of battery condition. If the cells of the battery do not have the same specific gravity, the battery should be replaced. When the specific gravity of all the cells is good or bad, the voltage of the battery must be considered before coming to a conclusion about the battery's condition. A battery with low specific gravity and acceptable voltage is normally only discharged, perhaps due to a charging system problem. However, a battery with good specific gravity readings but low voltage readings is always bad and needs to be replaced.

## Optical Refractometer

A **refractometer** uses the refractions of light to determine and display a very accurate specific gravity reading. All that is required is a couple of drops of electrolyte to be placed on the glass slide of the refractometer (Figure 5-15). While you hold the lens of the meter up to your eye, the light will refract through the sample and display the specific gravity in the window (Figure 5-16).



**SPECIAL TOOLS**  
Refractometer



**FIGURE 5-15** Placing a sample of electrolyte onto the refractometer's slide.

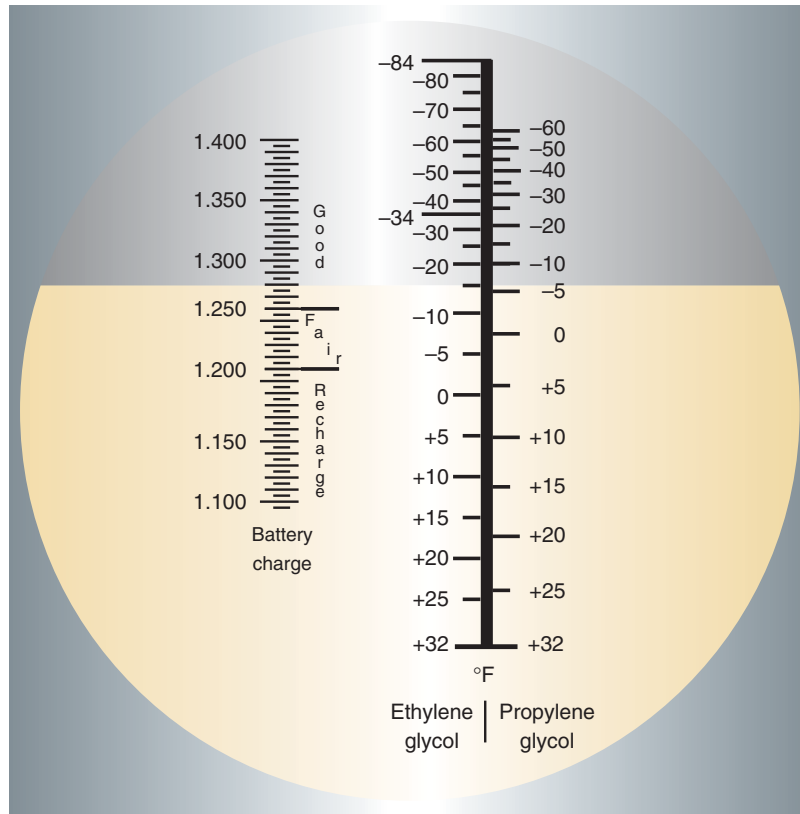


FIGURE 5-16 The window will indicate the specific gravity.



### SPECIAL TOOLS

- Digital voltmeter
- Fender covers
- Safety glasses

## Open Circuit Voltage Test

The **open circuit voltage test** is used to determine the battery's state of charge. It is used when a hydrometer is not available or cannot be used. To obtain accurate open circuit voltage test results, the battery must be stabilized. To **stabilize** the battery means the surface charge is removed by placing a large load on the battery for 15 seconds. If the battery has just been recharged, perform the capacity test, then wait at least 10 minutes to allow battery voltage to stabilize. Connect a voltmeter across the battery terminals, observing polarity (Figure 5-17). Measure the open circuit voltage. Take the reading to the 1/10 volt.



FIGURE 5-17 Open circuit voltage test using a voltmeter.

Open Circuit Voltage Table	
Open Circuit Voltage	Charge Percentage
11.7 volts or less	0%
12.0 volts	25%
12.2 volts	50%
12.4 volts	75%
12.6 volts or more	100%

© Delmar/Cengage Learning

**FIGURE 5-18** Open circuit voltage test results relate to the specific gravity of the battery's cells.

To analyze the open circuit voltage test results, consider that a battery at a temperature of 80°F (26.7°C), in good condition, should show about 12.4 volts. If the state of charge is 75% or more, the battery is considered “charged.” The relationship between open circuit voltage test results and charge percentage is illustrated (Figure 5-18).

## Capacity Test

The **capacity test** provides a realistic determination of the battery’s condition. For this test to be accurate, the battery must pass the state of charge or open circuit voltage test. If it does not, recharge the battery and test it again.

In the capacity test, a specified load is placed on the battery while the terminal voltage is observed. A good battery should produce current equal to 50% of its cold-cranking rating (or three times its ampere-hour rating) for 15 seconds and still provide 9.6 volts to start the engine.

Depending on the equipment used, certain steps need to be followed. If the tester uses a carbon pile to load the battery, follow the general steps outlined in Photo Sequence 8.

Once the load test is completed and you have recorded the voltage value, the readings need to be corrected to electrolyte temperature (Figure 5-19).

If voltage level is below the specifications listed in Figure 5-19, observe the battery voltage for the next 10 minutes. If the voltage raises to 12.45 volts or higher, the battery must be replaced. This means that the battery can hold a charge but has insufficient cold-cranking amperes.

If the voltage does not return to 12.4 volts, recharge the battery until the open circuit test indicates a voltage of 12.66 volts. Repeat the capacity test. If the battery fails again, replace the battery.

If the capacity test readings of a clean and fully charged battery are equal to or above specification, the battery is good. If the battery tests are borderline, perform the 3-minute charge test.

Electrolyte Temperature	70 +	60	50	40	30	20	10	0
	°F							
°C	21 +	16	10	4	-1	-7	-12	-18
Minimum Voltage (12-Volt Battery)	9.6	9.5	9.4	9.3	9.1	8.9	8.7	8.5

© Delmar/Cengage Learning

**FIGURE 5-19** Correcting the readings of the capacity test to temperature readings.



### SERVICE TIP:

If the vehicle has many circuits that place a constant drain on the battery (computer, clock, memory radios, etc.), the negative battery cable should be disconnected before taking a voltmeter reading.

### Classroom Manual

Chapter 5, page 126



### SPECIAL TOOLS

- VAT-60
- Electrolyte thermometer
- Safety glasses
- Fender covers

The capacity test is also called the “load test.”



### CAUTION:

While performing the load test, do not load the battery longer than 15 seconds.

# PHOTO SEQUENCE 8

## PERFORMING A BATTERY CAPACITY TEST

All photos in this sequence are © Delmar/Cengage Learning.



**P8-1** Charge the battery to at least 75% and allow the battery to stabilize.



**P8-2** Determine the rating on the battery's label and figure the load test specification.



**P8-3** Determine the temperature of the electrolyte. If the case is sealed, measure the temperature of the case.



**P8-4** Connect the large load leads across the battery terminals, observing polarity.



**P8-5** Confirm that the meter reads zero amperes. If needed, zero the ammeter.



**P8-6** Connect the ammeter's inductive pick-up around the negative load tester lead (not the battery's negative cable).

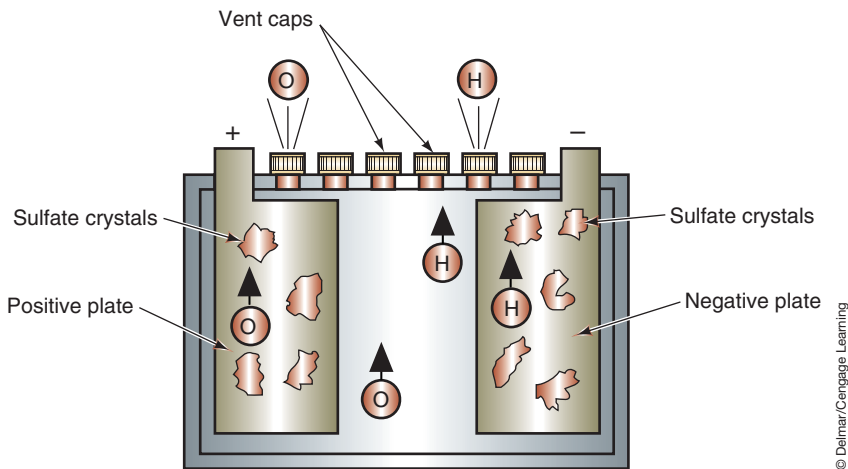


**P8-7** Turn the load control knob slowly until the ammeter indicates the amperage amount determined in step 2.



**P8-8** Read and record the voltmeter while applying the load for 15 seconds.





**FIGURE 5-20** A sulfated battery is the result of sulfate crystals that penetrate the plates. The crystals become insoluble and will not allow the battery cell to deliver current nor accept a charge.

## Three-minute Charge Test

If a conventional battery fails the load test, it is not always the fault of the battery. It is possible that the battery has not been receiving an adequate charge from the charging system. The **3-minute charge test** determines the battery's ability to accept a charge, and for **sulfation**. Sulfation is a chemical action within the battery that interferes with the ability of the cells to deliver current and accept a charge (Figure 5-20). A battery must have failed the load test to get accurate results from a 3-minute charge test.

### To conduct the 3-minute test:

1. Remove the ground cable. The battery must be disconnected from the vehicle's electrical system since the high voltage that is possible during this test can damage the computers.
2. Connect a battery charger to the battery, observing polarity.
3. Connect a voltmeter across the battery terminals, observing polarity.
4. Turn on the battery charger to 40 amperes (20–25 for maintenance-free batteries).
5. Maintain this rate of charge for 3 minutes.
6. Check the voltage reading at 3 minutes. If fewer than 15.5 volts, the battery is not sulfated. If the voltmeter reading is above 15.5 volts, the battery is sulfated or there is a poor internal connection.
7. If the battery passes the 3-minute test, slowly recharge the battery and do the load test again.
8. If the battery passes the load test this time, test the charging system.



**WARNING:** Some battery manufacturers, such as Delco, do NOT recommend the 3-minute charge test.

**CUSTOMER CARE:** One of the best things you can do for your customers is to assist them in choosing the correct battery. Battery selection needs to be based on the make of the vehicle, electrical options on the vehicle, driving habits, and climatic conditions. The largest current capacity rating that can be achieved in a given battery group may benefit some customers but may be a waste of money for others.

## Classroom Manual

Chapter 5, page 113



## SPECIAL TOOLS

Battery charger  
 Voltmeter  
 Safety glasses  
 Fender covers

## Computerized Load-Testing Equipment

Recently, automotive equipment manufacturers have developed battery load testers that use computer technology. With this type of equipment, the technician types in the CCA rating of the battery and the tester automatically performs the test. The results of the test are printed or displayed for the technician. Some systems will plot the voltages on a graph as the test is performed. The tester compares the results from the load test with its data for the CCA rating and makes a determination for the proper recommendation to the technician.



### SPECIAL TOOLS

Conductance Tester  
Battery Charger



### SPECIAL TOOLS

Test light  
DVOM  
VAT-60 or equivalent  
Multiplying coil  
Terminal pliers  
Terminal puller  
Cable clamp spreader  
Safety glasses  
Fender covers

## Battery Conductance Testing

**Conductance** is a measurement of the battery's plate surface that is available for chemical reaction. This determines how much power the battery can supply and describes the ability of a battery to conduct current. Conductance testing of the battery has proven to be a reliable test of the battery's capacity. The higher the conductance value (or lower internal resistance), the better the performance potential of the battery.

Conductance testing is performed by sending a low-frequency AC signal through the battery. A portion of the AC current's returned pulse is then captured and a conductance measurement is calculated. Conductance battery testers have the ability to accurately test batteries that are not fully charged. Battery internal damage is also detected without having to charge the battery. An on-screen display directs the technician through the steps required to perform the battery test (Figure 5-21).

A fully charged battery will have a conductance reading between 110% and 140% of its CCA rating. As the plate surfaces sulfate, it will lose its conductance. If the battery loses its cranking ability, the conductance will drop below the CCA rating. At this point, the battery will need to be replaced.

## BATTERY DRAIN TEST

If a customer complains that the battery is dead every time he attempts to start the vehicle after it has not been used for a short while, the problem may be a current drain from one of the electrical systems. The most common cause for this type of drain is a light that is not turning off—such as glove box, trunk, or engine compartment illumination lights.

These **parasitic drains** on the battery can cause various driveability problems. With low-battery voltage several problems can result; for example:

1. The computer may go into backup mode or “limp-in” mode of operation.
2. The computer may set false trouble codes.
3. To compensate for the low-battery voltage, the computer may raise the engine speed.



© Delmar/Cengage Learning

FIGURE 5-21 Conductance tester.



The procedure for performing the battery drain test may vary according to the manufacturer. However, battery drain can often be observed by connecting an ammeter in series with the negative battery cable or by placing the inductive ammeter pickup lead around the negative cable. If the meter reads 30 milliamps or more, there is excessive drain. Visually check the trunk, glove box, and under-hood lights to see if they are on. If they are, remove the bulb and watch the battery drain. If the drain is now within specifications, find out why the circuit is staying on and repair the problem. If the cause of the drain is not the lights, go to the fuse panel or distribution center and remove one fuse at a time while watching the ammeter. When the drain decreases, the circuit protected by the fuse you removed last is the source of the problem.

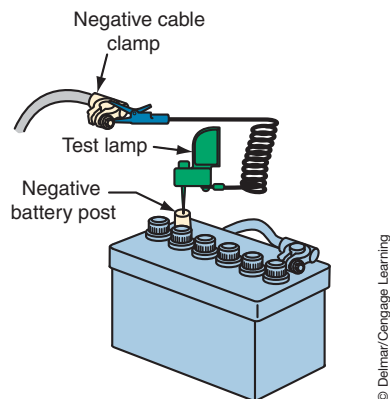
The following is a typical procedure for determining and locating parasitic drains against the battery. First, it is necessary to determine if a draw is occurring. This can be done by connecting an inductive ammeter clamp around the negative battery cable. The meter must be capable of reading less than 1 amp accurately. With all accessories turned off, the ammeter reading indicates the current draw against the battery. It is normal for some vehicles to have higher than 30 milliamps draw for up to an hour after the ignition switch is turned off. This allows the computers to perform their “administrative” tasks. Be sure to confirm the normal time-out period with the proper service information. If the ammeter reads higher than allowed current, the cause of the drain must be determined.

If an inductive clamp is not used, then the ammeter needs to be connected in series with the negative battery cable and the battery terminal. In this case it may be advisable to use a test light in series with the negative battery cable and the battery terminal first (Figure 5-22). This is done to prevent the vehicle’s computers from powering down and then powering back up again when the ammeter is connected. The additional amperage of the computers powering back up may blow the fuse in the ammeter. Prior to disconnecting the clamp from the terminal, connect the test lamp. As the clamp is removed, maintain connection of the lamp with the clamp and terminal. If the test light is on, there is a drain against the battery that is sufficient to light the lamp. After the time period has expired, the test light should go out. If not, then connect the ammeter leads in series between the cable and terminal (with the test light still connected). Once the ammeter is connected, remove the test light and read the amount of current draw.

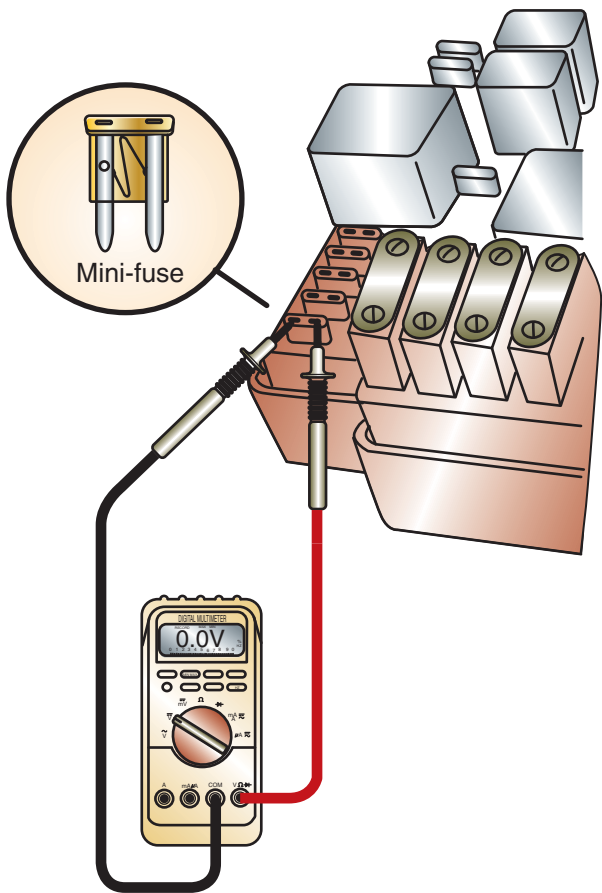
An alternate method of isolating the circuit that has the excessive drain is to measure the voltage drop across the fuse. Since a fuse may protect several circuits, it is possible to mask the problem when a fuse is pulled. For example, if a fuse protects the power supply circuits to three different computers, then pulling that fuse will cause them all to totally turn off. Usually a computer does not turn off completely when it powers down, but the draw is very slight. If one of the three computers was failing to power down, then excessive drain would be against the battery. If the fuse is pulled and all three computers power

The open circuit voltage reading must be 11.5 volts or higher to perform the battery drain test.

If the vehicle is equipped with computer-controlled air suspension systems, it may be necessary to disconnect the module to eliminate it from the test.



**FIGURE 5-22** Using a test light to prevent the vehicle’s computers from powering down.



**FIGURE 5-23** Using a voltmeter across a fuse to determine if current is flowing in the circuit.

Fuse Value	Fuse Type	Divide by
5	Mini	16.5
10	Mini	7.5
15	Mini	4.5
20	Mini	3.5
25	Mini	2.5
30	Mini	2.0
20	Cartridge	1.0
30	Cartridge	1.5
40	Cartridge	1.0
50	Cartridge	0.5

**FIGURE 5-24** Determining how much current is flowing through a fuse.

down, it is possible that the defective computer will reset and when the fuse is plugged in again there no longer will be a parasitic load. Since pulling the fuse caused the load reading on the ammeter to drop, the circuit is identified. However, once the fuse was plugged back in, the load is no longer indicated and isolating the cause is made more difficult. It would be advantageous to identify the circuit first, then unplug the computers one at a time until the draw is identified.

To perform this method of circuit identification, use the test tabs on the top of the fuse (maxi-fuses will require removing the lens). Connect a voltmeter set on the millivolt scale across the test points and observe the meter's reading (Figure 5-23). A fuse has resistance so that it can get hot and burn through if excessive current passes through it; this resistance will provide a voltage drop. If there is no (or very little) current flowing through the circuit, then the voltmeter will read 0 volts. However, if current is flowing through the circuit, then the voltmeter will provide a reading. The reading will indicate how much current is flowing in the circuit, which is a function of the rating of the fuse (Figure 5-24). For example, if the voltmeter reads 20 millivolts when connected across a 15-amp fuse, then the current draw is  $20 \div 4.5 = 4.4$  amps. It is not important to determine the amount of current flow. You are not looking for 1 or 2 milliamps but more than 30 milliamps; therefore, any reading displayed on the voltmeter indicates excessive current flow.

## BATTERY REMOVAL AND CLEANING

It is natural for dirt and grease to collect on the top of the battery. If allowed to accumulate, the dirt and grease can form a conductive path between the battery terminals. This may result in a drain on the battery. Also, normal battery gassing will deposit sulfuric acid as the vapors

condense. Over a period of time, the sulfuric acid will corrode the battery terminals, cable clamps, and holddown fixtures. As the corrosion builds on the terminals, it adds resistance to the entire electrical system.

Periodic battery cleaning will eliminate these problems. To be able to clean the battery correctly, it is best to remove it from the vehicle. Removing the battery protects the vehicle's finish and other under-hood components. Follow Photo Sequence 9 for the procedure for removing the battery from the vehicle and cleaning it. Consult the manufacturer's service information for precautions concerning the vehicle's computer controls.

When replacing the battery into the vehicle, make sure it is properly seated in the tray. Connect the holddown fixture and secure. Do not overtighten the holddown fixture. Install the positive cable and secure, then install the negative cable. Be sure to observe polarity. Perform a battery terminal test to confirm good connections.

**CUSTOMER CARE:** Before installing the battery back into the vehicle, it is a good practice to clean the battery tray. First scrape away any heavy corrosion with a putty knife. Next, clean the tray with a baking soda and water solution (Figure 5-26). Flush with water and allow to dry. After the tray has dried, paint it with rust-resistant paint. After the paint has completely dried, coat the tray with silicone base spray. These extra steps will protect the tray from corrosion.



FIGURE 5-25 Battery terminal pliers.

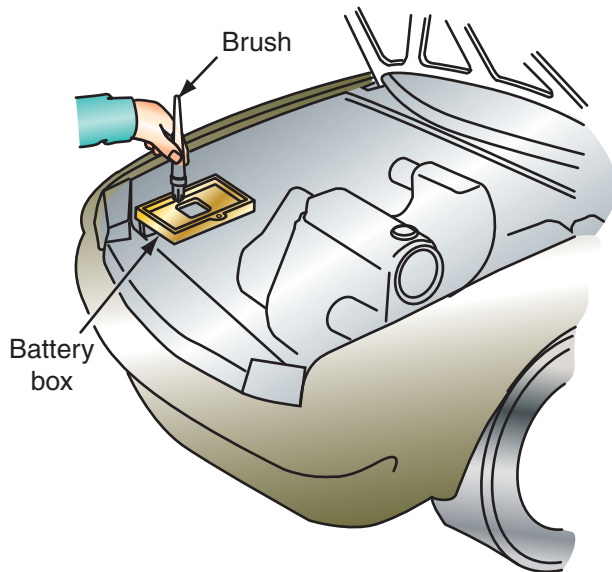


FIGURE 5-26 After scraping the battery tray clean with a putty knife, use the baking soda mixture to remove all electrolyte residues.



### SPECIAL TOOLS

- Baking soda
- Cleaning brushes
- Terminal pliers (Figure 5-25)
- Cable clamp spreader
- Terminal puller
- Terminal and clamp cleaning tool
- Battery-lifting strap
- Putty knife
- Protective terminal coating
- Safety glasses
- Heavy rubber gloves
- Fender covers



### CAUTION:

Do not allow the baking soda solution to enter the battery cells. This will neutralize the acid in the electrolyte and destroy a battery.

The baking soda and water solution consists of 1 table-spoon per quart of water.



# PHOTO SEQUENCE 9

## REMOVING AND CLEARING THE BATTERY

All photos in this sequence are © Delmar/Cengage Learning.



**P9-1** Tools needed to remove the battery from the vehicle include rags, baking soda, pan, terminal pliers, cable clamp spreader, terminal puller, assorted wrenches, terminal and clamp cleaning tool, battery lifting strap, safety glasses, heavy rubber gloves, rubber apron, and fender covers.



**P9-2** Place the fender covers on the vehicle to protect the finish.



**P9-3** Loosen the clamp bolt for the negative cable using terminal pliers and wrench of correct size. Be careful not to put excessive force against the terminal.



**P9-4** Use the terminal puller to remove the cable from the terminal. Do not pry the cable off of the terminal.



**P9-5** Locate the negative cable away from the battery.



**P9-6** Loosen the clamp bolt for the positive cable and use the terminal puller to remove the cable. If the battery has a heat shield, remove it.



**P9-7** Disconnect the hold down fixture.



**P9-8** Using the battery-lifting clamp, remove the battery out of the tray. Keep the battery away from your body. Wear protective clothing to prevent acid spills onto your hands.



**P9-9** Transport the battery to the bench. Keep it away from your clothes.



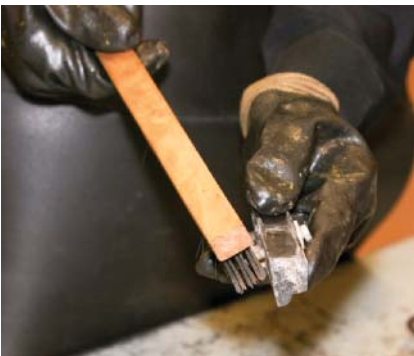
**P9-10** Mix a solution of baking soda and water.



**P9-11** Brush the solution over the battery case. Be careful not to allow the solution to enter the cells of the battery.



**P9-12** Flush the solution off with water.



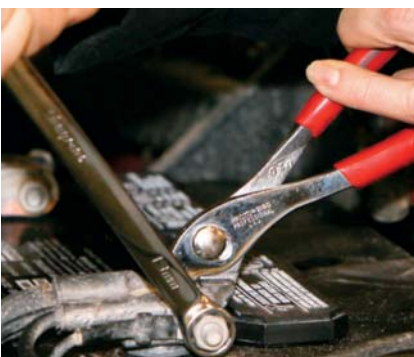
**P9-13** Use a wire brush to remove corrosion from the hold-down brackets.



**P9-14** Use the terminal cleaning tool to clean the cable.



**P9-15** Use the cleaning tool to clean the battery posts.



**P9-16** Install the battery into the tray and install the hold-down hardware. The cables are installed positive first, followed by the negative cable.



**P9-17** Coat the battery terminals with corrosion-preventive spray. Perform a terminal test to assure tight connections.





© Delmar/Cengage Learning

**FIGURE 5-27** A protective pad under the battery clamp prevents corrosion of the clamp and terminal.



**WARNING:** Be careful not to touch the positive terminal with the wrench when tightening the negative cable clamp.

Spray the cable clamps with a protective coating to prevent corrosion. A little grease or petroleum jelly will prevent corrosion as well. Also, protective pads are available that go under the clamp and around the terminal (Figure 5-27).

## JUMPING THE BATTERY



### SPECIAL TOOLS

Booster battery  
Jumper cables  
Fender covers  
Safety glasses



**WARNING:** Before charging a battery that has been in cold weather, check the electrolyte for ice crystals. Do not attempt to charge a frozen battery. Forcing current through a frozen battery may cause it to explode. Allow it to warm at room temperature for a few hours before charging.

There will be times when you will have to use a boost battery and jumper cables to jump start a vehicle (Figure 5-28). It is important that all safety precautions be followed. Jump-starting a dead battery can be dangerous if it is not done correctly. The following steps should be followed to safely jump-start most vehicles:

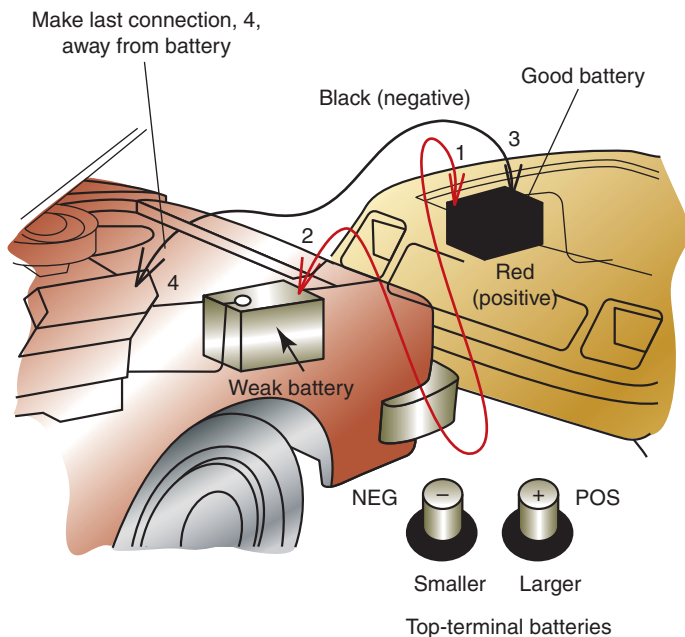
1. Make sure the two vehicles are not touching each other. The excessive current flow through the vehicles' bodies can damage the small ground straps that attach the engine block to the frame. These small wires are designed to carry only 30 amperes. If the vehicles are touching, as much as 400 amperes may be carried through them.
2. For each vehicle, engage the parking brake and put the transmission in neutral or park.
3. Turn off the ignition switch and all accessories, on both vehicles.
4. Attach one end of the positive jumper cable to the disabled battery's positive terminal.
5. Connect the other end of the positive jumper cable to the booster battery's positive terminal.
6. Attach one end of the negative jumper cable to the booster battery's negative terminal.
7. Attach the other end of the negative jumper cable to an engine ground on the disabled vehicle.



**WARNING:** Do not connect this cable end to the battery negative terminal. Doing so may create a spark that will cause the battery to explode.

8. Attempt to start the disabled vehicle. If the disabled vehicle does not start readily, start the jumper vehicle and run at fast idle to prevent excessive current draw.





**FIGURE 5-28** Proper jumper cable connections and sequence for jump starting a vehicle.

© Delmar/Cengage Learning

9. Once the disabled vehicle starts, disconnect the ground-connected negative jumper cable from its engine block.
10. Disconnect the negative jumper cable from the booster battery.
11. Disconnect the positive jumper cable from the booster battery, then from the other battery.



**WARNING:** A battery that has been rapidly discharged will create hydrogen gas. Do not attach jumper cables to a weak battery if starting the vehicle has been attempted. Wait for at least 10 minutes before connecting the jumper cable and attempting to start the vehicle.



**CAUTION:**

Do not use more than 16 volts to jump-start a vehicle that is equipped with an engine control module. The excess voltage may damage the electronic components.

## HV BATTERY SERVICE

It is important to remember that most hybrid vehicles have two separate batteries. One is the high-voltage (HV) battery pack; the other is the conventional 12-volt battery. In most hybrids, the HV battery pack provides the electrical power to start the engine and powers the electric motors. The 12-volt battery is used to power the basic electrical system, such as the lights, accessories, and power equipment. When diagnosing a problem with the HV battery, it is important to consider that the 12-volt battery also supplies the power for the electronic controls that monitor and regulate the operation of the hybrid system. If the 12-volt battery source is not operating properly, then hybrid system will not either. Consequently, the 12-volt system should never be ignored when working on an HV system.

Most hybrid vehicles have a continuous drain on the 12-volt battery system. In addition, the HV battery pack will drain if it is not being used. When servicing the batteries on a HEV, remember that if the battery's voltage drops below a specific level, the emissions MIL and/or hybrid warning lights may illuminate. Due to the battery drain when the vehicle is not in use, most manufacturers recommend that HEVs be started and run for at least 10 minutes every

**Classroom Manual**

Chapter 5, page 121

DMM  
Scan tool

month. This keeps the HV battery charged enough to operate the vehicle. However, it may not be enough to keep the 12-volt battery properly charged.

Before working on or around the HV battery and energy systems be sure to review all safety warnings, precautions, and procedures outlined in Chapter 1. Remember that these are guidelines; specific instructions and safety warnings will be provided in the manufacturer's service literature. Following these safety precautions is not limited to servicing of the electrical system, all services including air-conditioning, engine, transmission, and bodywork may require services completed around and/or with HV systems. If there is any doubt as to whether something has high voltage or not, or if the circuit is sufficiently isolated, **test it!!**

A **battery ECU** monitors the condition of the HV battery assembly. The battery ECU determines the SOC of the HV battery by monitoring voltage, current, and temperature. The battery ECU collects data and transmits it to the HV ECU to be used for proper charge and discharge control.

The battery ECU also controls the operation of the battery blower motor to maintain proper HV battery temperature.

The HV battery stores power generated by MG1 and recovered by MG2 during regenerative braking (Figure 5-29). The HV battery must also supply power to the electric motor when the vehicle is first started from a stop or when additional power is needed. A typical HV battery uses several nickel-metal-hydrate modules and can provide over 270 volts (Figure 5-30)

When the vehicle is moving, the HV battery is subjected to repetitive charge and discharge cycles. The HV battery is discharged by MG2 during acceleration mode and then is recharged by regenerative braking. An amperage sensor (Figure 5-31) is used so the battery ECU can transmit requests to the HV ECU to maintain the SOC of the HV battery. The battery ECU attempts to keep the SOS at 60 percent. The battery ECU also monitors delta SOC to determine if it is capable of maintaining acceptable levels of charge. The normal, low-to-high SOC delta is 20 percent.

MG1 functions as the control element for the planetary gear set. It recharges the HV battery and supplies electrical power to drive MG2. MG1 also functions as the starter for the engine. MG2 is used for power at low speeds and for supplemental power when needed at higher speeds.

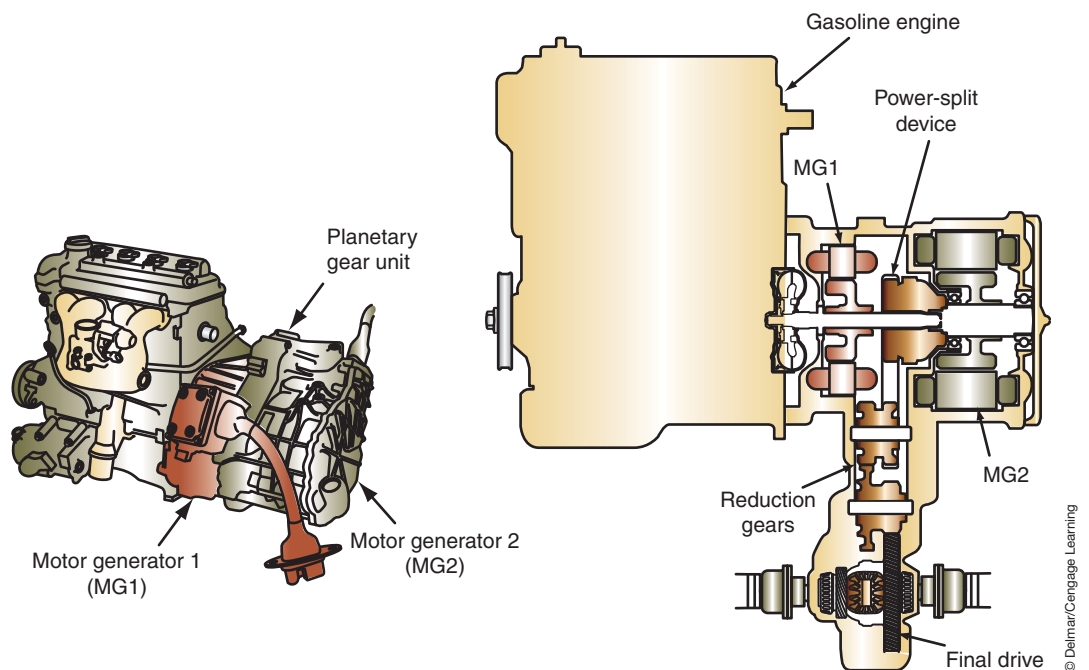


FIGURE 5-29 Layout of the generating HEV transaxle.

© Delmar/Cengage Learning



**FIGURE 5-30** The modules of the HV battery.

© Delmar/Cengage Learning



**FIGURE 5-31** The amperage sensor.

© Delmar/Cengage Learning

If the battery ECU sends abnormal messages to the HV ECU, the HV ECU, the HV ECU illuminates the warning light and centers fail-safe control. DTCs and informational codes are set along with freeze frame data. Fail-safe control and set DTCs. This will occur if the battery ECU determines the insulation resistance of the power cable is 100k ohms or less.

Whenever an HV battery malfunction occurs, use the scan tool to view the “HV Battery Data List.” This provides all HV battery system information. Since the HV battery is usually constructed of a series of modules, the scan tool may display the voltage for each module. Usually a module will have 7.2 volts so the scan tool reading should be in the range between 7 and 8 volts for each module. Some manufacturers will combine two modules to make a block with a normal voltage of 14.4 volts. The scan tool reading for each block should be between 14 and 16 volts (Figure 5-32). Regardless of how the scan tool displays the voltage readings, compare each reading with the others. They should be within 0.3 volts of each other when the contactors are open. If any of the voltage readings are higher or lower than the others, that module or block may be damaged.



**SERVICE TIP:**  
If inspection and testing fail to locate the leak, then it is possible that water entered into the battery assembly or into the converter/inverter assembly.

Data Display - 8PCM			
	Name	Value	Unit
▲	State of Charge	45.9	X
	Battery Voltage (cell sum)	303.5	Volts
	Min Block Voltage	16.2	Volts
	Max Block Voltage	16.2	Volts
	Block 1 voltage	15.2	Volts
	Block 2 voltage	15.2	Volts
	Block 3 voltage	15.2	Volts
	Block 4 voltage	16.2	Volts
	Block 5 voltage	15.2	Volts
	Block 6 voltage	15.2	Volts
	Block 7 voltage	15.2	Volts
	Block 8 voltage	15.2	Volts
	Block 9 voltage	16.2	Volts
	Block 10 voltage	16.2	Volts
	Block 11 voltage	15.2	Volts
	Block 12 voltage	15.2	Volts
	Block 14 voltage	15.2	Volts
	Block 15 voltage	15.2	Volts
	Block 16 voltage	15.2	Volts
	Block 17 voltage	15.2	Volts
	Block 19 voltage	15.2	Volts
	Block 29 voltage	15.2	Volts
▼	High Voltage Sensor	303.0	Volts

FIGURE 5-32 Scan tool reading of HV battery voltages.



### SERVICE TIP:

Some battery blocks may read 0 volts when the service plug is removed. Be sure to confirm proper voltages with the service information.

The scan tool may also display the HV battery SOC. Based on the SOC of the HV battery, the hybrid controller will perform the following:

- 6% SOC all vehicle operation shut down
- 35% SOC e-motors are not used (drive is disabled)
- 40% SOC e-motors are de-rated
- 50% SOC engine restarts to charge HV battery
- Approximately, 52% to 68% SOC normal operating range
- 80% SOC regenerative braking is disabled
- 94% SOC all vehicle operation shut down

If the scan tool does not display the HV battery voltages, then it will be necessary to test the battery with a DMM. This may require removal of the HV battery pack from the vehicle and the removal of the battery's case.

## High-Voltage Battery Charging

The HV battery is charged when the vehicle is driven, or when the engine is running. This is the best method of charging the HV battery pack. If the SOC of the HV battery is too low to allow the engine to run, the HV battery will need to be recharged. This may require the use of a special high-voltage battery charger. In addition, most manufacturers will only allow specially trained people to recharge the battery. Some manufacturers will not even supply the charging equipment to the dealer; a representative of the company performs the task of recharging the HV battery.

HV battery recharging must be performed outside. The correct cable is connected between the vehicle and the charger (Figure 5-33). When using the charger, the immediate area must be secured and marked with warning tape. It will require about three hours to recharge the battery to an SOC of about 50 percent.

Some manufactures provide a **jump assist** feature so the HV battery can be charged without special charging equipment. The process can be initiated by pushing a button or using a scan tool. The purpose of jump assist is to transfer enough energy from the 12-volt battery to the HV battery to allow the engine to be started. Jump assist does not fully charge the HV battery; it works to start the engine so the system can recharge the HV battery. The HV system needs to recharge the HV battery after a jump assist is performed.

When jump assist is initiated, one of the hybrid system modules (depending on manufacturers and system) converts the 12 volts into high-voltage DC. The HV current is routed to the HV battery pack until a calibrated amount of charge (amp hrs) has been delivered and the HV battery is above a specified voltage (300 volts, for example). At this time, the charging process is complete and the electric motors should start the engine successfully.

Depending on the manufacturer, HV battery condition, and temperature, the jump assist function may take up to an hour to complete.



### SPECIAL TOOLS

High-voltage battery charger  
Warning tape



### SCAN TOOLS

300 amp charger

Jump assist is also referred to as "Charge assist."

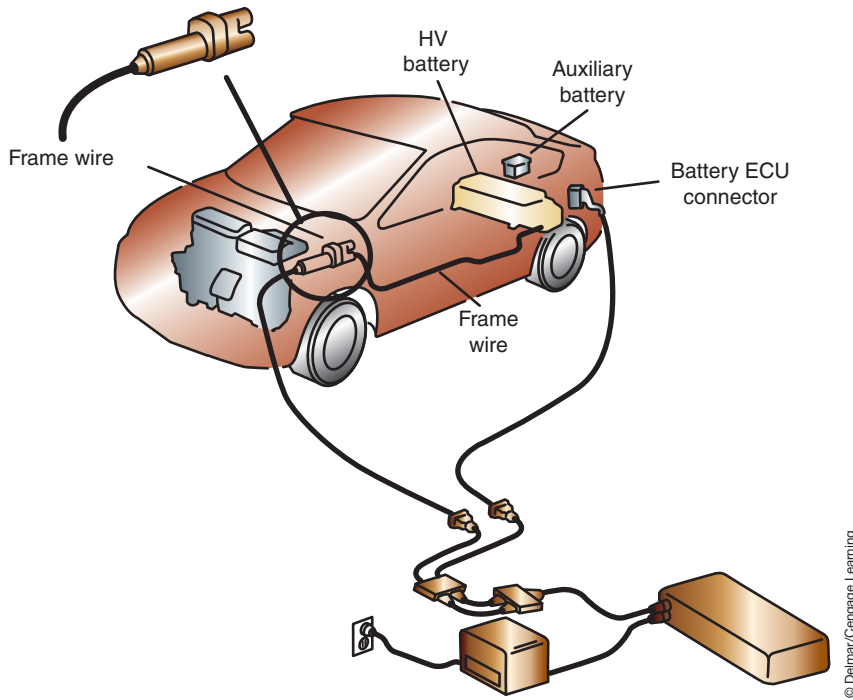


FIGURE 5-33 HV battery charger connection.

**CUSTOMER CARE TIP:** It is unusual for the HV battery to lose enough charge to not start the engine; anytime the HV battery requires recharging or jump assist, inspect the HV system for failures. The HV battery will drain to a low SOC if the vehicle is not driven for an extended amount of time. Most manufactures require the vehicle to be used at least 10 minutes every month to keep the HV battery charged.

On some vehicles, jump assist is automatically initiated after a failed crank has occurred. This will happen if an engine crank is requested from the driver and the HV system does not have enough energy to start the engine. For automatic jump assist to occur, the HV battery SOC must be at least 40% and the HV battery voltage must be between 200 and 358 volts. The driver is notified that the jump assist mode has been activated by a message on the HEV monitor screen (Figure 5-34).



**CAUTION:**

Do not activate the jump assist mode for an extended period. The 12-volt battery will be damaged because of excessive current transfer.

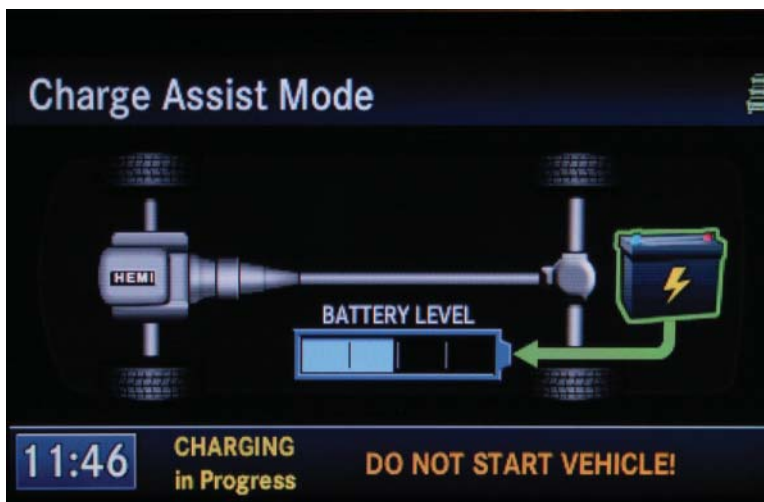


FIGURE 5-34 The drive is notified if an automatic jump assist is being performed after a failed crank.



Some manufactures provide scan tool initiation of the jump assist. Scan tool initiation of jump assist mode bypasses any voltage requirements that occur with a failed crank. This mode usually requires that a 30-ampere battery charge be applied to the 12-volt battery during the process. To assure a successful jump assist note the following tips:

- The charger must have an output of at least 30 amperes.
- Do not charge the battery with the charger set on “High” or “Jump.”
- Make sure to leave the ignition key in the OFF position to provide the HV battery with all available current.
- To prevent damage to the 12-volt battery, do not charge the HV battery through the 12-volt battery for an extended period.
- Be sure to disconnect the battery charger as soon as the jump assist is completed.
- A low 12-volt system does not require a jump assist procedure. If the 12-volt battery is low, a traditional jump start is required.

Following a successful jump assist, the HEV monitor screen and the scan tool will confirm the procedure was completed.

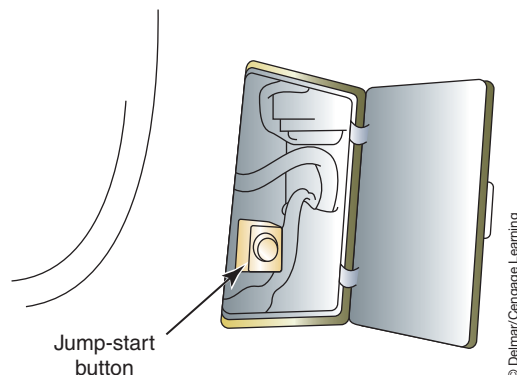
The jump assist feature can be aborted if any of the following occurs:

- The key is turned to the START position when the system is being charged.
- The 12-volt battery charger has been installed incorrectly (reversed cables).
- The 12-volt battery charger is removed.
- The control module determines conditions are not suitable for charging.

If a Ford Escape or Mariner Hybrid fails to start and the HV battery needs to be charged, a button is provided to initiate the process. First, make sure the ignition is in the OFF position. Next, open the access panel on the driver’s side foot well. Located behind this access is the jump-start button (Figure 5-35). Press the button then wait at least eight minutes before continuing. If you attempt to continue before the eight minutes have elapsed, the energy from the 12-volt battery will not be able to supply enough power to start the engine by the battery pack.

Pressing the jump-start button sends a request that the system send energy from the 12-volt battery to the HV battery pack. If the 12-volt battery has ample energy, it will be enough to start the engine. However, if the auxiliary battery is weak, it should be jump-started rather than the high-voltage battery pack.

After the eight minute wait time, the HEV system warning lamp will start to blink. After the warning lamp stops blinking (this may take up to two minutes), attempt to start the engine. If the engine still does not start, wait a couple of minutes and repeat the procedure again. If the engine still does not start, the low-voltage battery must be recharged or the vehicle jump-started through the 12-volt battery.



**FIGURE 5-35** Jump assist button located in kick panel.



## RECYCLING BATTERIES

The materials used to make lead-acid batteries can be recycled. This is the best practice for removal of used batteries. Batteries should not be discarded with regular trash, as they contain metals and chemicals that are hazardous to the environment. The Rechargeable Battery Recycling Corporation (RBRC) was established to promote recycling of rechargeable batteries in North America. RBRC collects batteries from consumers and businesses and sends them to recycling companies. Ninety-eight percent of all lead-acid batteries are recycled (Figure 5-36). During the recycling process, the lead, plastic, and acid are separated. All of these compounds may be used in the manufacturing of new batteries.

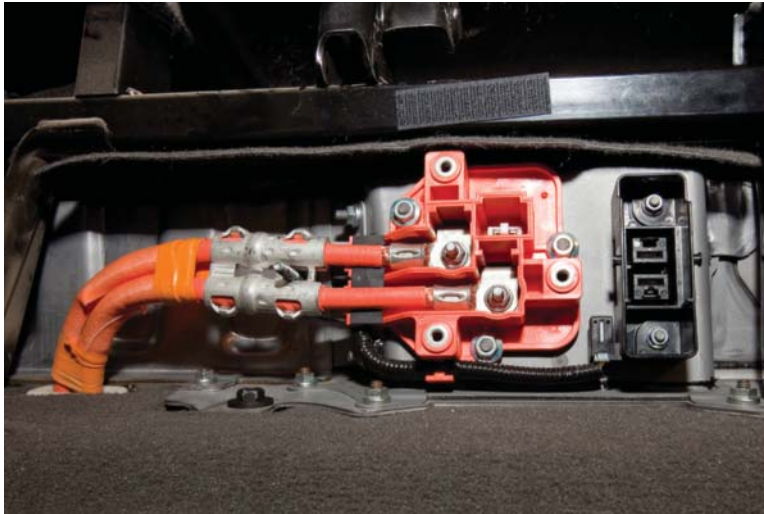
High-voltage NiMH batteries contain several components, including nickel, copper, and steel, which have value as recycled materials. Properly sealed NiMH batteries that are not leaking are considered dry cell batteries and are not hazardous waste. However, always refer to federal, state, local, and provincial laws and regulations governing the recycling of these batteries. If NiMH batteries are found to be leaking, they are regulated as hazardous waste under federal and state regulations.



### CAUTION:

A battery should never be incinerated. Doing this can cause an explosion.

**AUTHOR'S NOTE:** In California, NiMH batteries must be managed under California Universal Waste Rules.



© Delmar/Cengage Learning

**FIGURE 5-36** Recycled batteries may become new batteries and other products.

## TERMS TO KNOW

Battery ECU  
Battery leakage test  
Battery terminal test  
Capacity test  
Charge  
Charge rate  
Charge rate  
Fast charging  
Hydrometer  
Jump assist  
Open circuit voltage test  
Parasitic drains  
Refractometer  
Slow charging  
Stabilize  
State of charge  
Sulfation  
3-minute charge test

## CASE STUDY

A customer complains that the vehicle will not start without having to jump the battery. The technician learns that this happens every time the customer attempts to start the vehicle. The customer also says the voltmeter in the dash has been reading higher than normal.

The technician verifies the complaint. The engine turns over very slowly for a few seconds then does not turn. After jumping the battery to get the vehicle into the shop, the technician makes a visual inspection of the battery and cables. The open circuit voltage test shows a voltage of 12.5 volts across the terminals. When the battery is subjected to the capacity

test, the voltage drops to 7.8 volts at 80 degrees. After 10 minutes, the open circuit voltage is back up to 12.5 volts. The technician determines that the battery is sulfated. The battery can't handle the load of cranking the engine, which is why it always needs to be jumped. The higher-than-normal voltmeter readings indicate the charging system is trying to keep the battery charged. The technician calls the customer with a price quote. The customer agrees to have the battery replaced. While replacing the battery, the technician cleans the battery tray, the cable clamps, and sprays the clamps with a corrosion protector.

## ASE-STYLE REVIEW QUESTIONS

- Battery terminal connections are being discussed.  
*Technician A* says when disconnecting battery cables, always disconnect the negative cable first.  
*Technician B* says when connecting battery cables, always connect the negative cable first.  
Who is correct?  
A. A only                      C. Both A and B  
B. B only                      D. Neither A nor B
- A customer's battery is always dead when she attempts to start her car in the morning. After jumping the battery one time in the morning, the car will start throughout the day with no problems. All of the following can be the cause EXCEPT:  
A. The starter motor is drawing too much current.  
B. The glove box light is staying on.  
C. A computer is not powering down.  
D. A relay contact is stuck closed.
- The specific gravity of a battery has been tested. All cells have a corrected reading of about 1.200.  
*Technician A* says the battery needs to be recharged before further testing.  
*Technician B* says the battery is sulfated and needs to be replaced.  
Who is correct?  
A. A only                      C. Both A and B  
B. B only                      D. Neither A nor B
- When charging a battery:  
A. Connect a voltmeter across the battery terminals while the battery is charging and keep the charge rate at fewer than 10 volts.  
B. Disconnect the negative battery cable before charging to prevent damage to the alternator and computers.  
C. Charge at an amperage rate of 50% of the CCA rating.  
D. All of the above.

5. Which statement concerning the battery leakage test is correct?
- The test is used to determine if the battery can provide current and voltage when loaded.
  - A voltmeter reading of 0.05 when performing the test is acceptable.
  - Both A and B.
  - Neither A nor B.
6. The open circuit test is being discussed.  
*Technician A* says the battery must be stabilized before the open circuit voltage test is performed.  
*Technician B* says a test result of 12.4 volts is acceptable.  
 Who is correct?
- A only
  - B only
  - Both A and B
  - Neither A nor B
7. A maintenance-free battery has failed the capacity test.  
*Technician A* says if the voltage recovers to 12.45 volts, the battery is still good.  
*Technician B* says if the voltage level does not return to 12.4 volts, recharge the battery and repeat the capacity test.  
 Who is correct?
- A only
  - B only
  - Both A and B
  - Neither A nor B
8. *Technician A* says the best way to charge the HV battery by allowing the engine to run. *Technician B* says usually an onboard jump assist method is available to start the engine if the HV battery SOC is too low. Who is correct?
- A only
  - B only
  - Both A and B
  - Neither A nor B
9. While jump-starting a vehicle, a puff of smoke is observed and the engine ground cable is burned.  
*Technician A* says this happened because the two vehicles were touching.  
*Technician B* says this was caused by connecting the negative jumper cable to the disabled vehicle's engine ground.  
 Who is correct?
- A only
  - B only
  - Both A and B
  - Neither A nor B
10. Ice crystals are found in the electrolyte. This can be caused by:
- A discharged battery.
  - Use of tap water
  - Reversed battery connections.
  - Improper holddowns.

## ASE CHALLENGE QUESTIONS

---

1. Charging a battery with a battery charger is being discussed.  
*Technician A* says that battery-charging voltage should never exceed 15 volts.  
*Technician B* says that a battery can be considered fully charged when its open circuit voltage exceeds 12.1 volts after it has been stabilized.  
Who is correct?  
A. Technician A    C. Both A and B  
B. Technician B    D. Neither A nor B
2. *Technician A* says that a battery terminal test is performed by placing voltmeter leads between the positive battery post and the negative battery terminal.  
*Technician B* says that the total amount of voltage drop between the negative battery post and the negative battery terminal should not exceed 300 mV.  
Who is correct?  
A. Technician A    C. Both A and B  
B. Technician B    D. Neither A nor B
3. *Technician A* says that an ammeter is used when performing a battery leakage test.  
*Technician B* says that a fully charged battery will have a specific gravity of at least 1.265.  
Who is correct?  
A. Technician A    C. Both A and B  
B. Technician B    D. Neither A nor B
4. *Technician A* says that the 3-minute charge test is performed after a battery has failed a capacity test.  
*Technician B* says that if battery voltage is below 15.5 volts at the end of the 3-minute charge test the battery is probably sulfated.  
Who is correct?  
A. Technician A    C. Both A and B  
B. Technician B    D. Neither A nor B
5. The battery current drain test is being discussed.  
*Technician A* says that an ammeter that can read as low as 20 mA should be used.  
*Technician B* says that a current drain caused by an internally shorted battery could not be measured with an ammeter.  
Who is correct?  
A. Technician A    C. Both A and B  
B. Technician B    D. Neither A nor B

Name \_\_\_\_\_ Date \_\_\_\_\_

## INSPECTING AND CLEANING A BATTERY

Upon completion of this job sheet, you should be able to visually inspect a battery.

### ASE Correlation

This job sheet is related to the ASE Electrical/Electronic System Certification Exam's content area: *Battery Diagnosis and Service*; task: Inspect, clean, fill, or replace battery.

### Tools and Materials

A vehicle with a 12-volt battery

A DMM

Safety glasses

Basic tool kit

Baking soda

Terminal cleaning brush

Battery cable puller

Wire brush

### Describe the vehicle being worked on:

Year \_\_\_\_\_ Make \_\_\_\_\_ Model \_\_\_\_\_

VIN \_\_\_\_\_ Engine type and size \_\_\_\_\_

### Procedure

1. Describe the general appearance of the battery.

---



---



---



---

2. Describe the general appearance of the cables and terminals.

---



---



---



---

3. Check the tightness of the cables at both ends. Describe their condition.

---



---



---

---

Task Completed

4. Connect the positive lead of the meter (set on DC volts) to the positive terminal of the battery.
5. Put the negative lead on the battery case, and move it all around the top and sides of the case. What readings do you get on the voltmeter?

---

---

---

6. What is indicated by the readings?

---

---

---

7. Measure the voltage of the battery. Your reading was:       volts.

8. Perform a battery terminal test for each cable and record your results:

Positive Cable \_\_\_\_\_

Negative Cable \_\_\_\_\_

9. What do you know about the condition of the battery based on the visual inspection and the tests that you did?

---

---

---

---

---

Instructor's Response \_\_\_\_\_

---

---



Name \_\_\_\_\_ Date \_\_\_\_\_

## REMOVING, CLEANING, AND INSTALLING A BATTERY

Upon completion of this job sheet, you should be able to remove, clean, and reinstall a battery.

### ASE Correlation

This job sheet is related to the ASE Electrical/Electronic System Certification Exam's content area: *Battery Diagnosis and Service*; task: Inspect, clean, fill, or replace a battery.

### Tools and Materials

- A vehicle with a 12-volt battery
- A wash pan
- A box of clean baking soda
- Water
- Cleaning brush
- Hand tools
- Battery cable puller
- Battery terminal cleaner and brushes
- Cable end spreader
- Safety glasses
- Rubber gloves

### Describe the vehicle being worked on:

Year \_\_\_\_\_ Make \_\_\_\_\_ Model \_\_\_\_\_  
 VIN \_\_\_\_\_ Engine type and size \_\_\_\_\_

### Procedure

Task Completed

**NOTE:** Before disconnecting the battery, record the stations of all preset buttons on the radio. Also, if the vehicle has memory seats or other like accessories, record those settings as well.

1. Disconnect the negative cable of the battery. Use the cable puller if the cable is difficult to remove.
2. Carefully remove the battery holddown strap. Describe the condition of the holddown.  
 \_\_\_\_\_  
 \_\_\_\_\_  
 \_\_\_\_\_
3. Disconnect the positive cable of the battery. Use the cable puller if the cable is difficult to remove. Move anything that may interfere with the removal of the battery.
4. With a terminal cleaner, clean off the terminals of the battery.
5. With a battery-carrying strap, remove the battery from the vehicle and place it on a workbench or on the floor close to a drain.

**Task Completed**

**6.** Inspect the battery tray. Describe its condition and your recommendations.

---

---

---

---

- 7.** Make a mixture of baking soda and water. The mixture should be like a paste.
- 8.** With the brush, scrub the top, sides, and bottom of the battery with the baking soda paste. Be careful not to allow the paste to get inside the battery.
- 9.** After all of the battery has been scrubbed, wash the paste off with clean water.
- 10.** Allow the battery to drip dry; then wipe the water off the battery with a clean rag.
- 11.** Use the leftover paste to clean the battery tray and the holddown assembly.
- 12.** Rinse these off with water.
- 13.** Use a clean, dry cloth to wipe the tray dry. Then reinstall the battery.
- 14.** Clean the battery cable terminals and spread them slightly with the spreader tool.
- 15.** Install the battery holddown assembly; make sure it is tight and that the battery is positioned properly.
- 16.** Connect the positive cable to the battery.
- 17.** Connect the negative cable to the battery.
- 18.** Reset all preset stations on the radio and other accessories with memory.

---

---

---

Instructor's Response \_\_\_\_\_

---

---

Name \_\_\_\_\_ Date \_\_\_\_\_

## TESTING THE BATTERY'S CAPACITY

Upon completion of this job sheet, you should be able to test a battery's capacity and determine needed service actions.

### ASE Correlation

This job sheet is related to the ASE Electrical/Electronic System Certification Exam's content area: *Battery Diagnosis and Service*; task: Perform battery capacity (load, high-rate discharge) test; determine needed service.

### Tools and Materials

- A vehicle with a 12-volt battery
- Service information
- Starting charging system tester (VAT-60 or similar)
- Safety glasses
- Fender covers

### Describe the vehicle being worked on:

Year \_\_\_\_\_ Make \_\_\_\_\_ Model \_\_\_\_\_  
 VIN \_\_\_\_\_ Engine type and size \_\_\_\_\_

### Procedure

Task Completed

1. Perform a battery state of charge test:
  - a. Record the specific gravity readings for each cell:  
 (1) \_\_\_\_\_ (2) \_\_\_\_\_ (3) \_\_\_\_\_ (4) \_\_\_\_\_ (5) \_\_\_\_\_ (6) \_\_\_\_\_
  - b. If the battery is a maintenance-free-type battery, what is the open circuit voltage?  
 \_\_\_\_\_ volts

2. Summarize the battery's state of charge from the above.  
 \_\_\_\_\_  
 \_\_\_\_\_  
 \_\_\_\_\_  
 \_\_\_\_\_

3. Connect the starting charging system tester to the battery.
4. Locate the rating of the battery. What is the rating? \_\_\_\_\_
5. Based on the rating, how much load should be put on the battery during the capacity test? \_\_\_\_\_ amps
6. Conduct a battery load test.  
 Battery voltage decreased to \_\_\_\_\_ volts after \_\_\_\_\_ seconds.

---

Task Completed

7. What is the specification for the vehicle being serviced? \_\_\_\_\_

8. Describe the results of the battery load (capacity) test. Include in the results your service recommendations and the reasons for them.

---

---

---

---

---

---

Instructor's Response \_\_\_\_\_

---

---

Name \_\_\_\_\_ Date \_\_\_\_\_

## USING A BATTERY CONDUCTANCE TESTER

Upon completion of this job sheet, you should be able to test a battery using a conductance tester and determine needed service action.

### ASE Correlation

This job sheet is related to the ASE Electrical/Electronic System Certification Exam's content area: *Battery Diagnosis and Service*; task: Perform battery capacity (load, high-rate discharge) test; determine needed service.

### Tools and Materials

A vehicle with a 12-volt battery  
 Service information  
 Conductance tester  
 Safety glasses  
 Fender covers

### Describe the vehicle being worked on:

Year \_\_\_\_\_ Make \_\_\_\_\_ Model \_\_\_\_\_  
 VIN \_\_\_\_\_ Engine type and size \_\_\_\_\_

### Procedure

1. Remove the battery from the vehicle. Task Completed \_\_\_\_\_
2. What is the CCA rating of the battery you are working on?  
 \_\_\_\_\_
3. What is the battery type? Lead-acid \_\_\_\_\_ AGM \_\_\_\_\_
4. Connect the test leads to the battery terminals observing polarity. What is the voltage displayed by the tester? \_\_\_\_\_
5. Press the **ENTER** button to receive on-screen instructions for setting the tester up.  
 Task Completed \_\_\_\_\_
6. Use the arrow keys to scroll to **SELECT TEST** and select **OUT-OF-VEHICLE**.  
 Task Completed \_\_\_\_\_
7. Continue to follow the on-screen instruction; then press ENTER to start the test.  
 Task Completed \_\_\_\_\_
8. Record the battery test results.  
 \_\_\_\_\_  
 \_\_\_\_\_

Instructor's Response \_\_\_\_\_  
\_\_\_\_\_  
\_\_\_\_\_



Name \_\_\_\_\_ Date \_\_\_\_\_

## HV BATTERY SERVICE AND DIAGNOSIS

Upon completion of this job sheet, you should be able to diagnose the condition of the HV battery.

### Tools and Materials

Scan tool

Safety glasses

Service information

### Describe the vehicle being worked on:

Year \_\_\_\_\_ Make \_\_\_\_\_ Model \_\_\_\_\_

VIN \_\_\_\_\_ Engine type and size \_\_\_\_\_

### Procedure

**WARNING** You will be working around high voltage while doing this job sheet. Follow all warnings and cautions in the manufacturer’s service procedures. Even though the service disconnect is removed, the HV battery is still “live.”

### Scan tool diagnostics

1. Use the scan to check for DTCs related to the HV battery and record your results:

\_\_\_\_\_

\_\_\_\_\_

2. Navigate to the battery control module and record the flowing information, if available (note you may need to modify the chart for the vehicle you are working on):

PID	READING	UNIT
Hybrid Battery State of Charge		%
Hybrid Battery Current Sensor		Amps
Module Voltage (1)		Volts
Module Voltage (2)		Volts
Module Voltage (3)		Volts
Module Voltage (4)		Volts
Module Voltage (5)		Volts
Module Voltage (6)		Volts
Module Voltage (7)		Volts
Module Voltage (8)		Volts
Module Voltage (9)		Volts
Module Voltage (10)		Volts
Module Voltage (11)		Volts

PID	READING	UNIT
Module Voltage (12)		Volts
Module Voltage (13)		Volts
Module Voltage (14)		Volts
Module Voltage (15)		Volts
Module Voltage (16)		Volts
Module Voltage (17)		Volts
Module Voltage (18)		Volts
Module Voltage (19)		Volts
Module Voltage (20)		Volts
HV Battery Impedance		Ohms
BPCM Package Voltage		Volts
BPCM HV Bus Voltage		Volts

3. Are all module voltages displaying approximately the same voltage values?

Yes    No

4. Remove the HV battery service disconnect plug and note if the voltage in any of the modules or blocks changes. \_\_\_\_\_

If there was a change, why did it occur?

\_\_\_\_\_

Instructor's Response \_\_\_\_\_

\_\_\_\_\_

DIAGNOSTIC CHART 5-1	
PROBLEM AREA:	Battery
SYMPTOMS:	No-start condition after vehicle is parked overnight.
POSSIBLE CAUSES:	<ol style="list-style-type: none"> <li>1. Glove box, trunk, interior illumination lights not turning off due to defective switches.</li> <li>2. Circuit short to ground.</li> <li>3. Circuit copper-to-copper shorts.</li> <li>4. Contaminated battery case.</li> </ol>

<b>DIAGNOSTIC CHART 5-2</b>	
PROBLEM AREA:	Battery
SYMPTOMS:	Battery requires jump-starting after engine shutdown.
POSSIBLE CAUSES:	1. Low specific gravity. 2. Defective battery cell(s).

<b>DIAGNOSTIC CHART 5-3</b>	
PROBLEM AREA:	Battery
SYMPTOMS:	Inadequate current to start engine under heavy load conditions and battery will not accept a charge.
POSSIBLE CAUSES:	1. Contaminated battery case resulting in constant current draw. 2. Contaminated battery terminals. 3. Undercharged battery. 4. Defective battery. 5. Sulfated battery. 6. Damaged battery.

<b>DIAGNOSTIC CHART 5-4</b>	
PROBLEM AREA:	Battery
SYMPTOMS:	Starter cranks engine slowly or fails to turn engine; low state of charge.
POSSIBLE CAUSES:	1. Discharged battery. 2. Contaminated terminal clamps. 3. Defective battery cables.

<b>DIAGNOSTIC CHART 5-5</b>	
PROBLEM AREA:	HV battery
SYMPTOMS:	Low SOC. Warning lamp illumination.
POSSIBLE CAUSES:	1. Poor electrical connections. 2. Faulty motor generator or circuits. 3. Faulty HV ECU or circuits. 4. Faulty battery ECU or circuits. 5. Faulty amperage sensor or circuits. 6. Faulty HV battery.

*This page intentionally left blank*

# STARTING SYSTEM DIAGNOSIS AND SERVICE



### BASIC TOOLS

Basic mechanic's tool set

Service information

## UPON COMPLETION AND REVIEW OF THIS CHAPTER, YOU SHOULD BE ABLE TO:

- Perform a systematic diagnosis of the starting system.
- Determine what can cause slow-crank and no-crank conditions.
- Perform a quick check test series to determine the problem areas in the starting system.
- Perform and accurately interpret the results of a current draw test.
- Perform and accurately interpret the results of an insulated circuit resistance test and a ground circuit test.
- Perform the solenoid test series and accurately diagnose the solenoid.
- Perform the no-crank test and recommend needed repairs as indicated.
- Diagnose the starter motor condition by use of the free speed test.
- Remove and reinstall a starter motor.
- Disassemble, clean, inspect, repair, and reassemble a starter motor.

## INTRODUCTION

Perhaps one of the most aggravating experiences to a car owner is to have an engine that will not start. However, not all starting problems are caused by the starting system. The ignition and fuel systems must also be in proper condition to perform their functions. In addition, the internal condition of the engine must be such that compression, correct valve timing, and free rotation are all obtained.

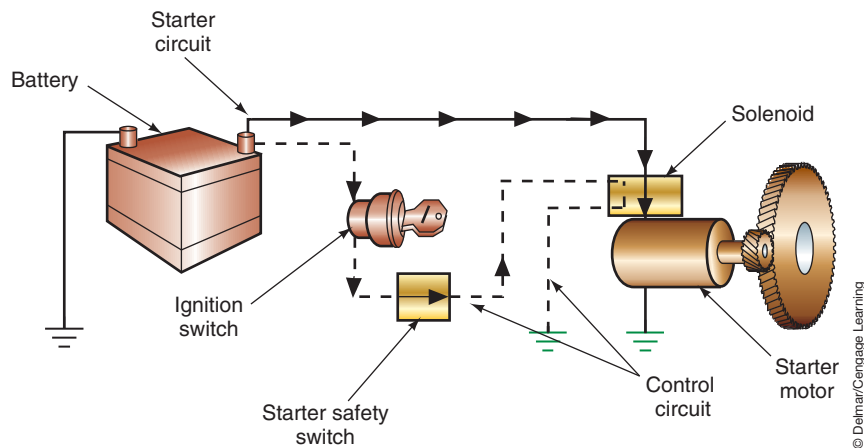
The starter motor must be capable of rotating the engine fast enough to start and run under its own power. The starting system is a combination of mechanical and electrical parts that work together to start the engine. The basic starting system includes the following components (Figure 6-1):

1. Battery.
2. Cable and wires.
3. Ignition switch.
4. Starter solenoid or relay.
5. Starter motor.
6. Starter drive and flywheel ring gear.
7. Starting safety switch.

In this chapter you will perform the required tests to make a decision concerning the condition and operation of these components. You will also remove, disassemble, reassemble, and reinstall the starter motor.

**Classroom  
Manual**

Chapter 6, page 133



**FIGURE 6-1** Major components of the starting system. The solid line represents the starting circuit, while the dashed line represents the starter control circuit.

© Delmar/Cengage Learning

## STARTING SYSTEM SERVICE CAUTIONS

Before beginning any service on the starter system, some precautions must be observed. Along with the precautions outlined in Chapter 1, when servicing the starter system several other precautions should be followed:

1. Refer to the manufacturer's manuals for correct procedures for disconnecting a battery. Some vehicles with on-board computers must be supplied with an auxiliary power source.
2. Disconnect the battery ground cable before disconnecting any of the starter circuit's wires or removing the starter motor.
3. Be sure the vehicle is properly positioned on the hoist or on safety jack stands.
4. Before performing any cranking test, be sure the vehicle is in PARK or NEUTRAL and the parking brakes are applied.
5. Follow the manufacturer's directions for disabling the ignition system.
6. Be sure the test leads are clear of any moving engine components.
7. Never clean any electrical components in solvent or gasoline. Clean with compressed air, denatured alcohol, or wipe with clean rags only.

**No crank** means that when the ignition switch is placed in the START position, the starter does not turn the engine. This may be accompanied by a buzzing noise, which indicates the starter motor drive has engaged the ring gear, but the engine does not rotate. There may also be no clicking sounds from the starter motor or solenoid.

**Slow cranking** means the starter drive engages the ring gear, but because the engine turns slowly it cannot start. Some manufacturers provide specifications for engine cranking speed.

## STARTING SYSTEM TROUBLESHOOTING

Customer complaints concerning the starting system generally fall into four categories: **no crank**, **slow cranking**, starter spins but does not turn engine, and excessive noise. As with any electrical system complaint, a systematic approach to diagnosing the starting system will make the task easier. First, the battery must be in good condition and fully charged. Perform a complete battery test series to confirm the battery's condition. Many starting system complaints are actually attributable to battery problems. If the starting system tests are performed with a weak battery, the results can be misleading. The conclusions may be erroneous and costly.

Before performing any tests on the starting system, first begin with a visual inspection of the circuit. Repair or replace any corroded or loose connections, frayed wires, or any other trouble sources. The battery terminals must be clean and the starter motor must be properly grounded.

The diagnostic chart shows a logical sequence to follow whenever a starting system complaint is made (Figure 6-2). What tests are performed is determined by whether or not the starter will crank the engine.



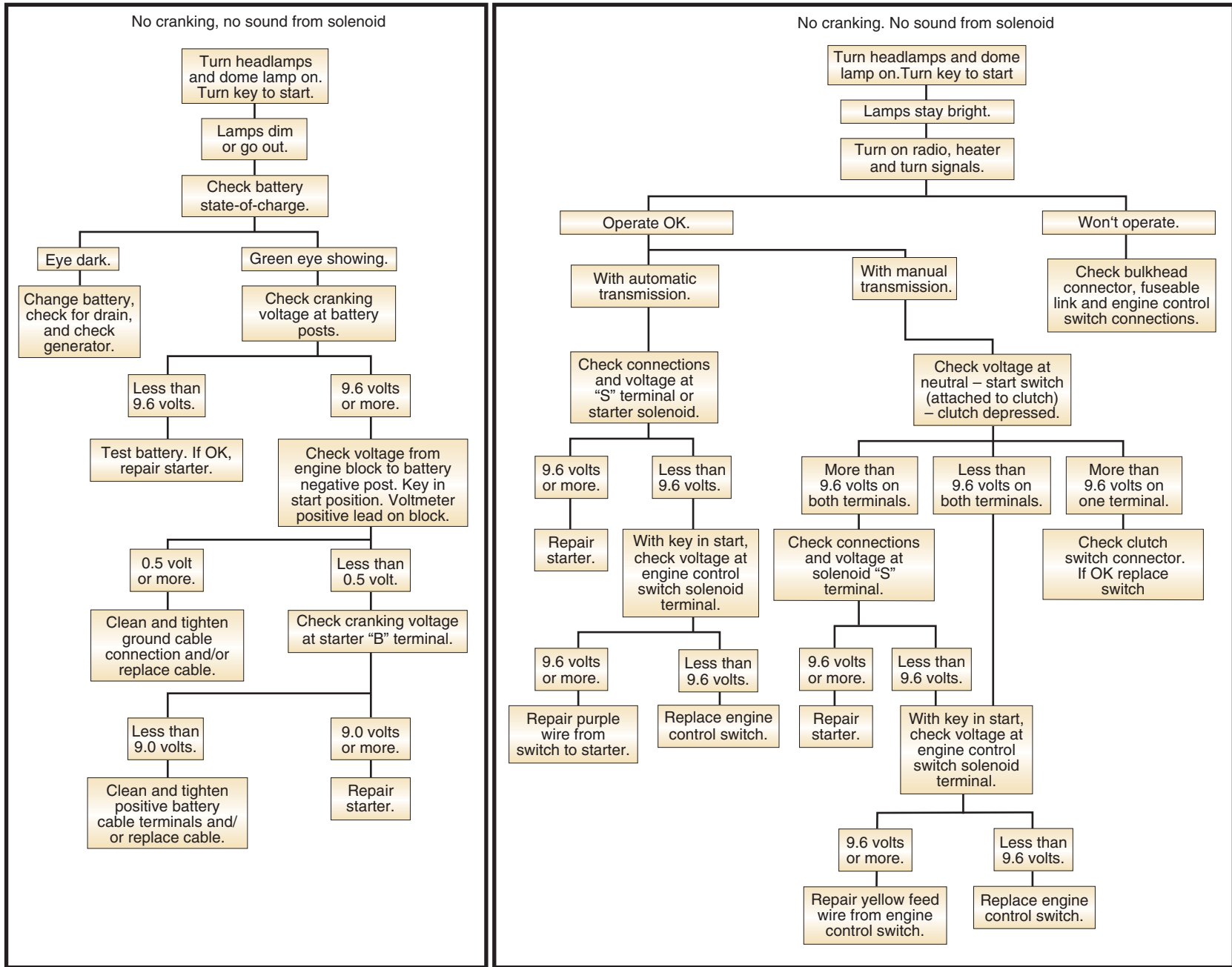


FIGURE 6-2 Starting system diagnostic chart.

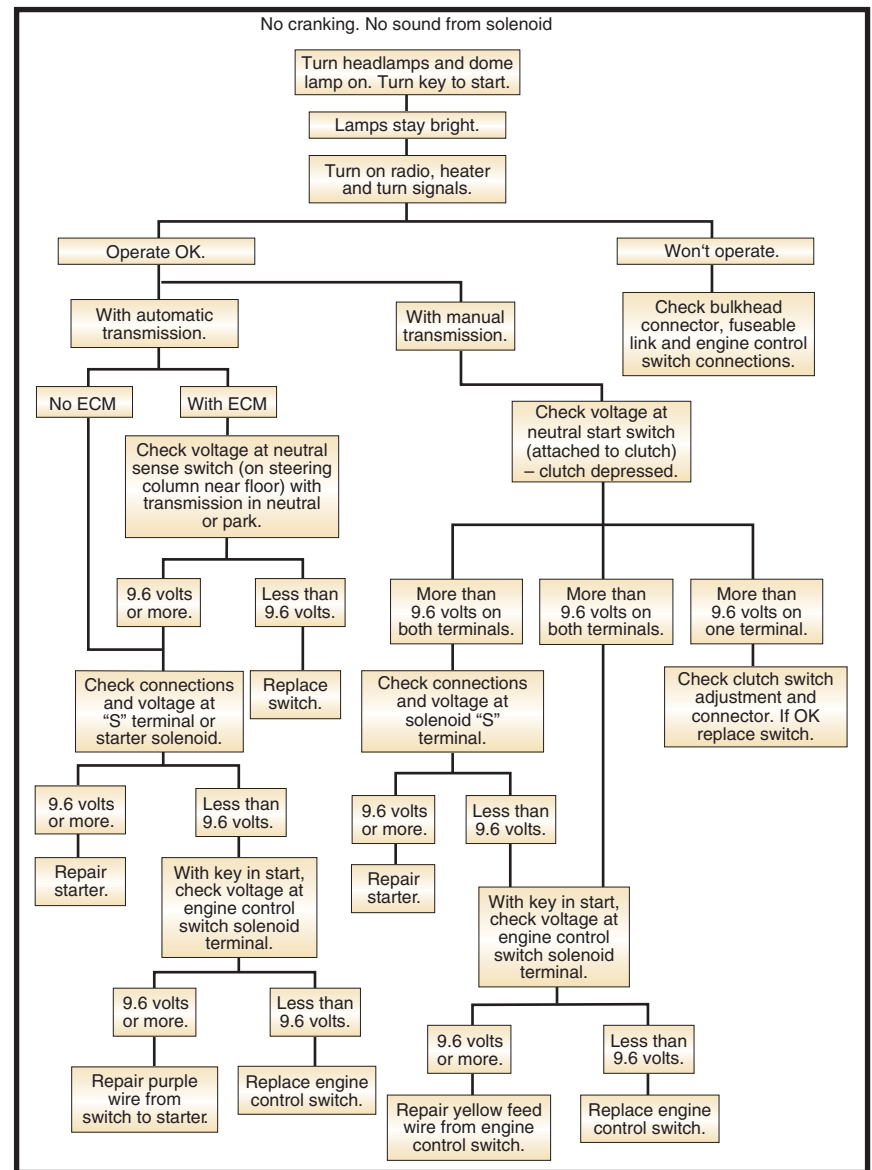
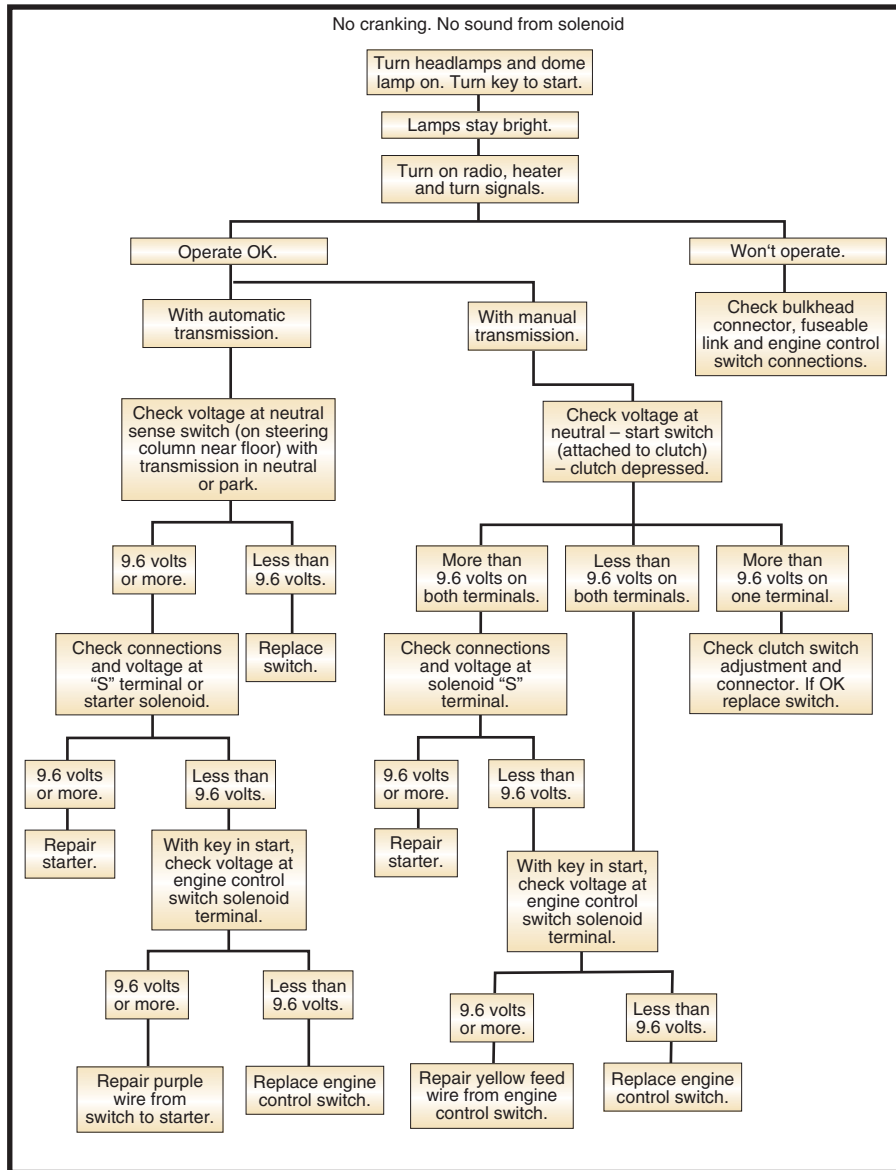


FIGURE 6-2 (Continued)

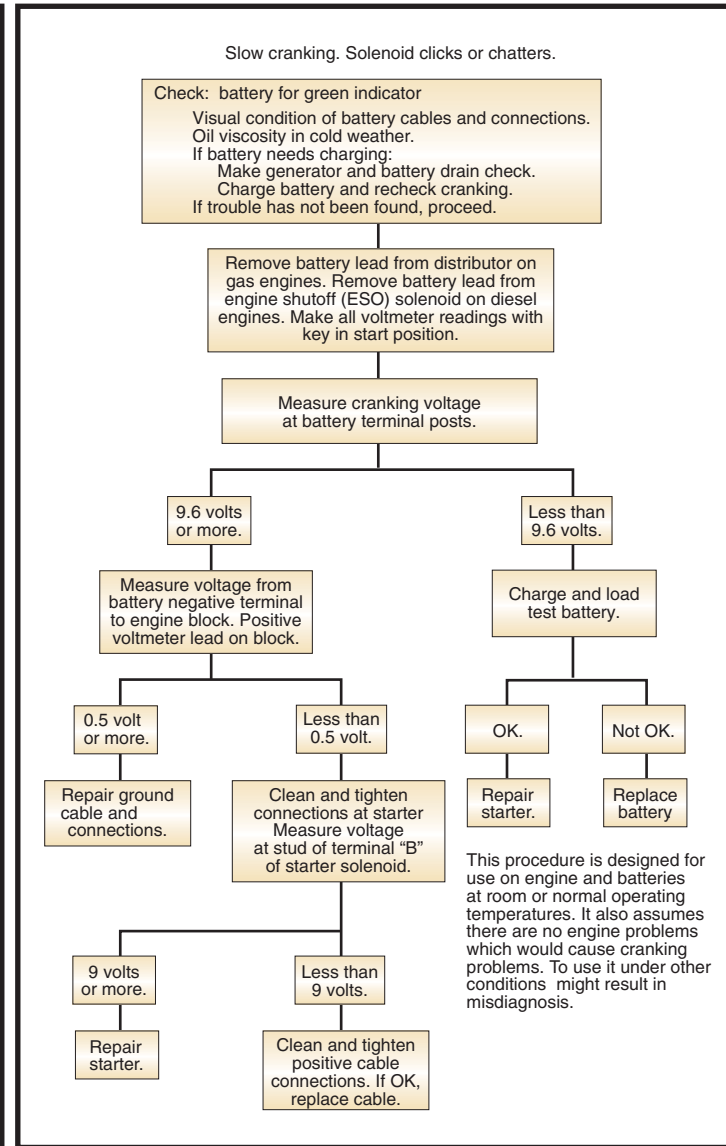
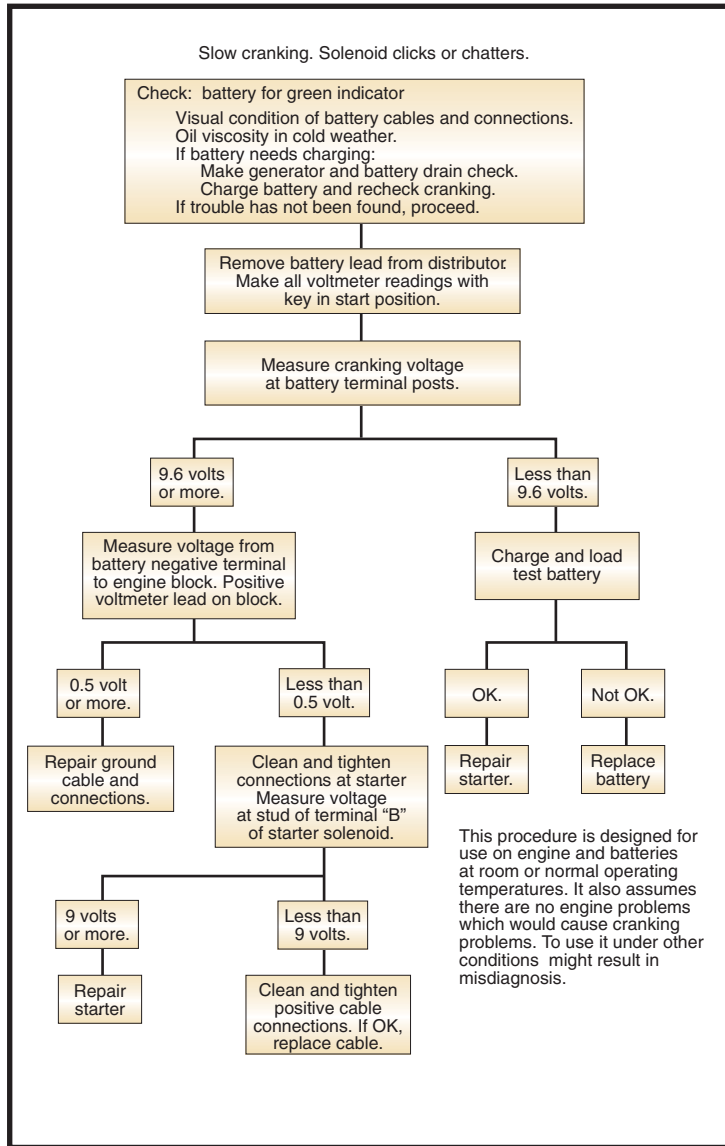
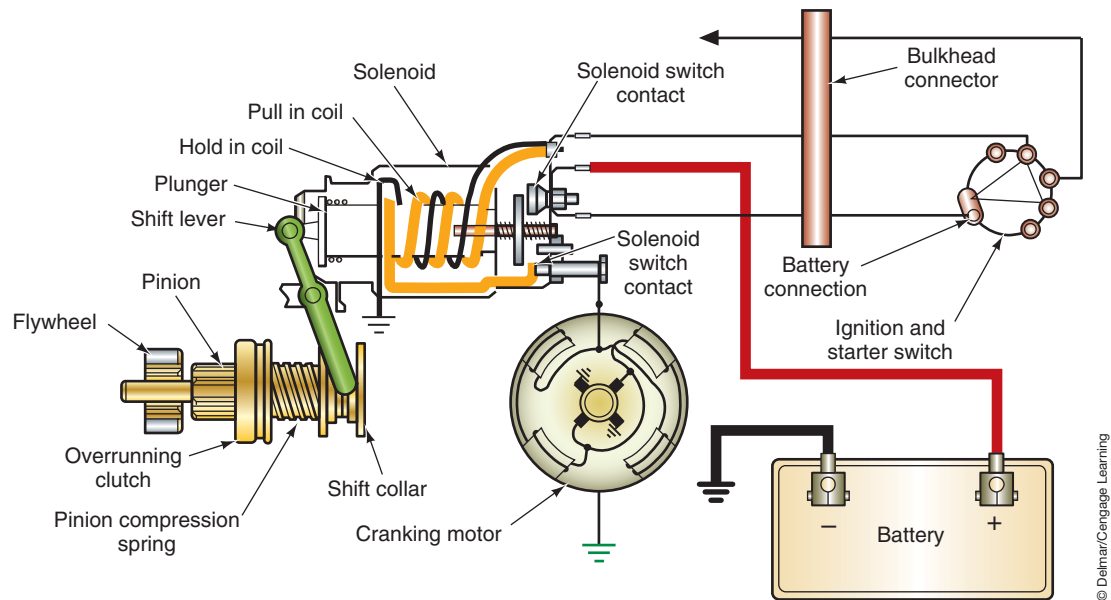


FIGURE 6-2 (Continued)



**FIGURE 6-3** Excessive wear, loose electrical connections, or excessive voltage drop in any of these areas can cause a slow crank or no-crank condition.

© Delmar/Cengage Learning

If the customer complains of a no-crank situation, attempt to rotate the engine by the crankshaft pulley bolt. Rotate the crankshaft two full rotations in a clockwise direction, using a large socket wrench. If the engine does not rotate, it may be seized due to its being operated with no oil, broken engine components, or **hydrostatic lock**. Since liquid cannot be compressed, if there is a leak that allows antifreeze from the cooling system to enter the cylinder, the cylinder can fill to such a level that the piston is unable to move upward. This condition is referred to as hydrostatic lock.

Several potential trouble spots in the circuit can cause a slow-crank or no-crank complaint. (Figure 6-3). Excessive voltage drops in these areas will cause the starter motor to operate slower than required to start the engine. The speed that the starter motor rotates the engine is important to engine starting. If the speed is too slow, compression is lost and the air/fuel mixture draw is impeded. Most manufacturers require a speed of approximately 250 rpm during engine cranking.

If the starter spins but the engine does not rotate, the most likely cause is a faulty starter drive. If the starter drive is at fault, the starter motor will have to be removed to install a new drive mechanism. Before faulting the starter drive, also check the starter ring gear teeth for wear or breakage, and for incorrect gear mesh of the ring gear and starter motor pinion gear.

Most noises can be traced to the starter drive mechanism. The starter drive can be replaced as a separate component of the starter.

**CUSTOMER CARE:** Always treat the customer's car with respect. Place fender covers over the fenders when performing tasks under the hood. Do not lay tools on the vehicle's finish. Clean your hands before entering the vehicle. Place a seat protector over the seats and paper mats on the floor boards. Give the car back to the customer at least as clean as when you received it.



© Delmar/Cengage Learning

**FIGURE 6-4** Starter tests can be performed with any tester capable of measuring high current, such as the VAT-60.

## TESTING THE STARTING SYSTEM

As with the battery testing series, the tests for the starting system are performed with a starting/charging system tester (Figure 6-4). The starter performance and battery performance are so closely related that it is important for a full battery test series to be done before trying to test the starter system. If the battery fails the load test and is fully charged, it must be replaced before doing any other tests.

### Quick Testing

The **quick test** will isolate the problem area and determine whether the starter motor, solenoid, or control circuit is at fault. If the starter does not turn the engine at all, and the engine is in good mechanical condition, the quick test can be performed to locate the problem area. To perform this test, make sure the transmission is in neutral and set the parking brake. Turn on the headlights. Next, turn the ignition switch to the START position while observing the headlights.

**There are three things that can happen to the headlights during this test:**

1. They will go out.
2. They will dim.
3. They will remain at the same brightness level.

If the lights go out completely, the most likely cause is a poor connection at one of the battery terminals. Check the battery cables for tight and clean connections. It will be necessary to remove the cable from the terminal and clean the cable clamp and battery terminals of all corrosion.

If the headlights dim when the ignition switch is turned to the START position, the battery may be discharged. Check the battery condition. If it is good, then there may be a mechanical condition in the engine that is preventing it from rotating. If the engine rotates when turning it with a socket wrench on the pulley nut, the starter motor may have internal damage. A bent starter armature, worn bearings, thrown armature windings, loose pole shoe screws, or any other worn component in the starter motor that will allow the armature to drag can cause a high current demand.

**Classroom  
Manual**

Chapter 6, page 133



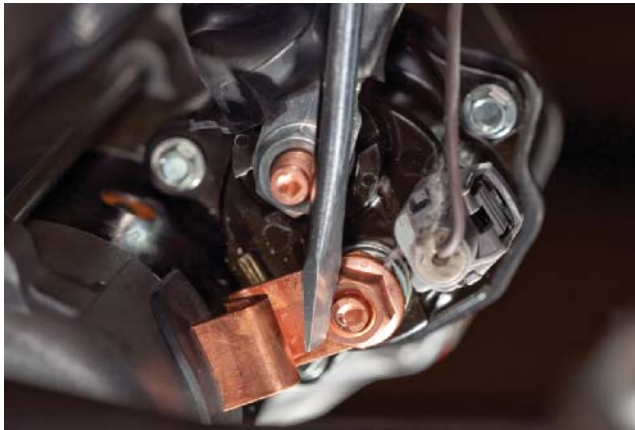
### SPECIAL TOOLS

Fender covers  
Jumper cables



### SERVICE TIP:

Check the fusible link if the engine does not crank and the headlights do not come on.



© Delmar/Cengage Learning

**FIGURE 6-5** By-passing the solenoid to determine if the solenoid or the control circuit is faulty.

**CUSTOMER CARE:** If the starter windings are thrown, this indicates several different problems. The most common is that the driver is keeping the ignition switch in the START position too long after the engine has started. Other causes include the driver opening the throttle plates too wide while starting the engine, which results in excessive armature speeds when the engine does start. Also, the windings can be thrown because of excessive heat buildup in the motor. The motor is designed to operate for very short periods of time. If it is operated for longer than 15 seconds, heat begins to buildup at a very fast rate. If the engine does not start after a 15-second crank, the starter motor needs to cool for about 2 minutes before the next attempt to start the engine.

If the lights stay brightly lit and the starter makes no sound (listen for a deep clicking noise), there is an open in the circuit. The fault is in either the solenoid or the control circuit. To test the solenoid, bypass the solenoid by bridging the BAT and S terminals (Figure 6-5).



**WARNING:** A starter can draw up to 400 amperes. The tool used to jump the terminals must be able to carry this high current and must have an insulated handle.

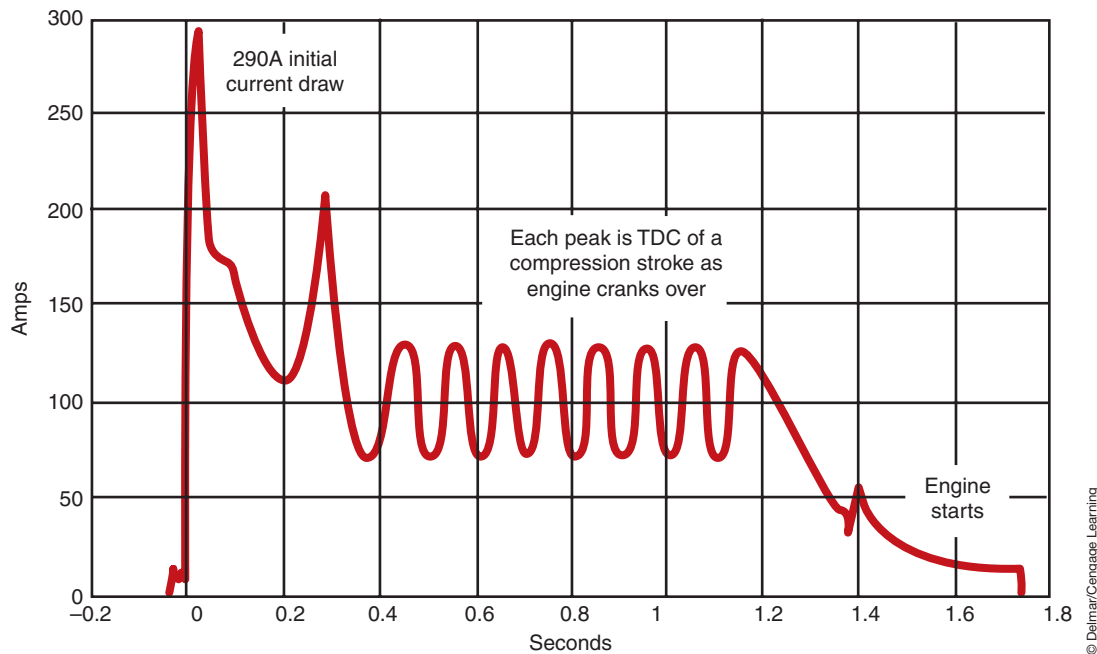
If the starter rotates with the solenoid bypassed, the control circuit is at fault. If the starter does not rotate and the lights do not dim, the solenoid is at fault. (Also, listen for the starter drive engaging.) If the starter rotates slowly and the headlights dim, there is excessive current draw and the system will have to be tested further.

## Lab Scope Testing

A lab scope or graphing multimeter is a good method of testing a starting system. Prior to disabling the ignition system to prevent the engine from starting, use the ammeter probe to view the starter signal. Most current probes convert amps to millivolts to be read on a lab scope. The amp probe is connected over either the positive or negative battery cable. Be sure to orient the arrow on the current probe with the direction of current flow. Set the scope settings of 0.5 volt/division and 100 ms/division to start with and adjust later as needed. Using the meter's record function will make interpretation of the pattern results easier.

To get the engine to rotate over requires high starter current. Once the engine is rotating, lower current is required. A typical pattern will indicate this higher current draw at initial cranking (Figure 6-6). During this time, both the pull-in and hold-in windings of the





**FIGURE 6-6** When the starter is energized, the current will spike and then drops as starter speed increases.

© Delmar/Cengage Learning

starter solenoid are energized. Shortly after the high current spike, the pull-in windings are de-energized and current will drop to a lower value. After the engine starts, the current draw drops to zero as the ignition switch is placed in the RUN position. Excessively high or low current indicates a problem with the circuit, such as a bad starter or resistance from corrosion or loose connections. At this time, current draw and circuit resistance testing will be required.

## Current Draw Test

The **current draw test** measures the amount of current that the starter draws when actuated. It determines the electrical and mechanical condition of the starting system. If the starter motor cranks the engine, the technician should perform the current draw test. The following procedure uses a typical starting/charging system tester and is similar to the procedure for other starting and charging system testers:

1. Connect the large red and black test leads across the battery, observing polarity.
2. Follow the manufacturer's instructions to zero the ammeter.
3. Connect the amps inductive probe around the battery ground cable. If more than one ground cable is used, clamp the probe around all of them (Figure 6-7).
4. Make sure all loads are turned off (lights, radio, etc.). Zero the ammeter.
5. Select STARTING TEST.
6. Follow the Service information procedure to disable the ignition system to prevent the vehicle from starting. Some systems may require that the fuel pump or EFI relay be removed or the ignition module be disconnected in order to prevent the engine from starting.
7. Crank the engine for 10–15 seconds and note the voltmeter and ammeter readings.

After recording the readings from the current draw test, compare them with the manufacturer's specifications. If specifications are not available, correctly functioning systems, as a rule, will crank at 9.6 volts or higher. Current draw is dependent on engine size. Most V-8 engines will have a current draw of about 200 amperes, six-cylinder engines about 150 amperes, and four-cylinder engines about 125 amperes.



### SPECIAL TOOLS

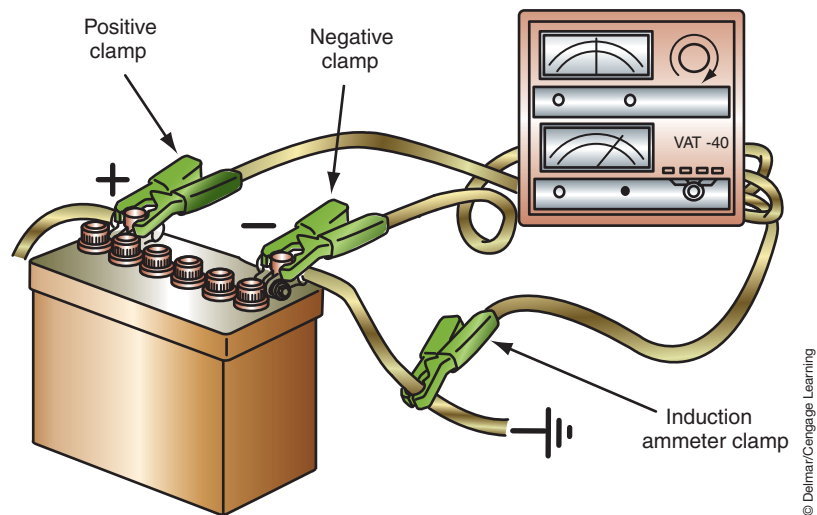
Fender covers  
Starting/charging system tester  
Jumper wires



### CAUTION:

Do not operate the starter motor for longer than 15 seconds. Allow the motor to cool between cranking attempts.

The specification for current draw is the maximum allowable; the specification for cranking voltage is the minimum allowable.



**FIGURE 6-7** Test lead connections to perform the starter current draw test.

If the readings obtained from the current draw test are out of specifications, then additional testing will be required to isolate the problem. If the readings were on the borderline of the specifications or there is an intermittent problem, then detailed testing for bad components will pinpoint potential failures.

The following provides an interpretation of the current draw test:

- Voltage is 9.6 volts or more and amperage is higher than specified—indicates impedance to rotation of the starter motor. This includes worn bushings, a mechanical blockage, and excessive advanced ignition timing. Shorted starter motor windings can cause high current draw.
- Voltage is 9.6 volts or more and amperage is lower than specified—indicates high electrical circuit resistance.
- Voltage is less than 9.6 volts and current is higher than specified—indicates the amperage is draining the battery. Perform the battery test series to confirm the battery is good. If the battery passes this test series, then see the first point above.
- Voltage is less than 9.6 volts and current is lower than specified—indicates a faulty battery.

Because the voltage reading obtained from the current draw test was taken at the battery, this reading may not be an exact representation of the actual voltage delivered to the starter. Voltage losses due to bad cables, connections, and relays (or solenoids) may diminish the amount of voltage to the starter. These should be tested before removing the starter from the vehicle.

## Relative Compression Testing

Although usually a test procedure for determining internal engine condition, compression testing is also used to identify hard starting conditions. Good compression and a properly functioning starting system are critical for fast starts and good driveability. Due to the increased difficulty of accessing spark plugs, normal compression testing by removing the spark plugs and installing a compression gauge is being replaced with a nonintrusive diagnostic routine referred to as **relative compression testing**. Relative compression testing uses current draw during cranking to determine if a cylinder has lower compression relative to the other cylinders. This test also provides a good indication of the starting system.

Every time a piston is forced up during the compression stroke, it takes work. Since current represents work, the lab scope provides a method of observing current on a small

timeline scale; with the scope you can visualize the effect that each cylinder's compression stroke has on starter current while the engine is cranking.

To perform this test, clamp the lab scope's amp probe around the starter cable between the battery and the starter motor. With the ignition system disabled, crank the engine while monitoring the lab scope pattern. As discussed earlier, the initial current should go high and peak, followed by a ripple pattern (Figure 6-8). As the pistons approach top dead center compression stroke, the resistance increases and causes the current trace to also increase. This should result in a trace with even peaks across the screen. If compression of a cylinder is lower than that of other cylinders, then the current peak of that cylinder will also be lower (Figure 6-9).

By using an external trigger placed around a spark plug, it is possible to identify which cylinder has the low compression. Once the trigger is installed onto the spark plug, adjust the scope to trigger off this signal. For example, if the lab scope is set to trigger off of the rpm pickup that was placed on the number one plug wire, then every time the screen is updated, the number one cylinder is the first one on the screen. By following the engine's firing order, each cylinder number can be determined.

Most engine analyzers have a variation of this test that will test the relative current comparison of each cylinder during cranking. These analyzers provide a readout of the results and may suggest the faulty cylinder.

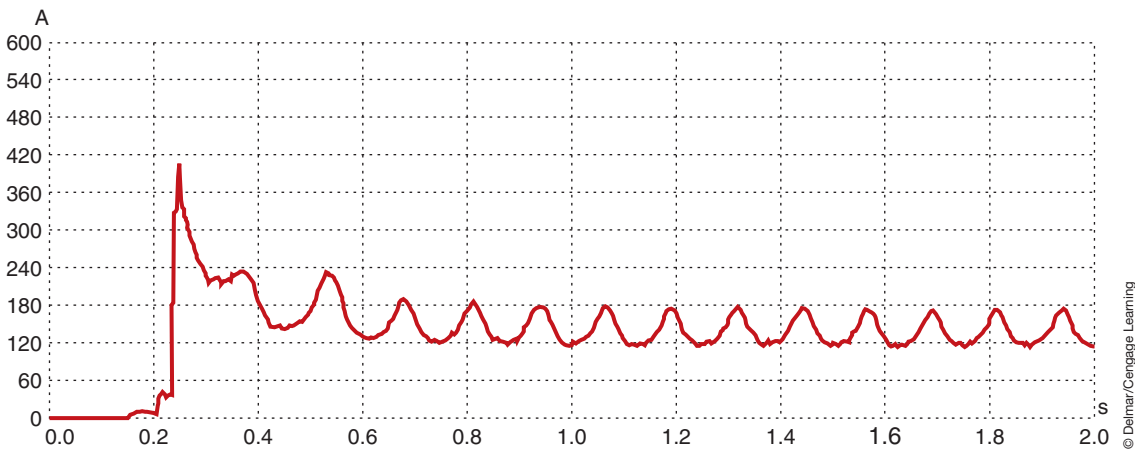


FIGURE 6-8 Lab scope pattern showing good relative compression between cylinders.

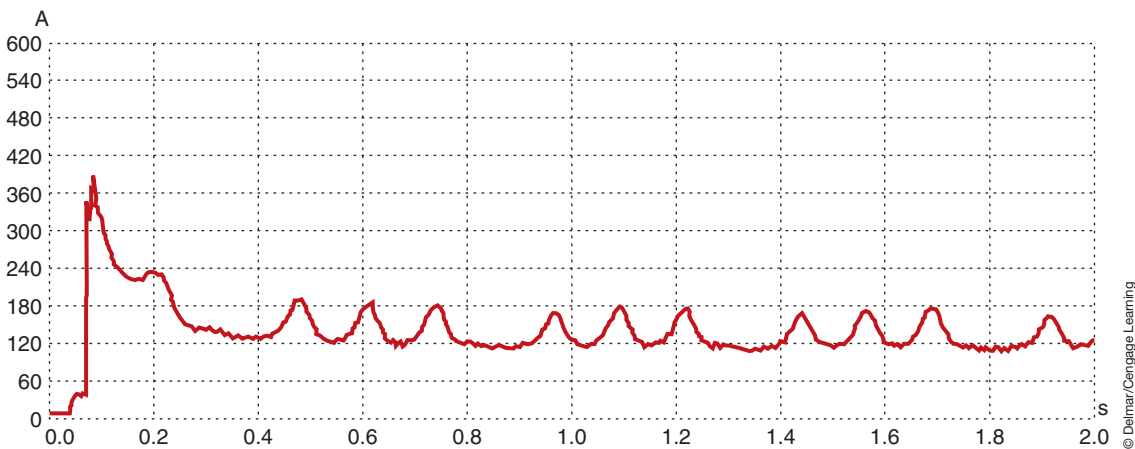


FIGURE 6-9 Lab scope pattern indicating a cylinder with lower relative compression.



### SPECIAL TOOLS

Voltmeter  
Fender covers  
Starting/charging system tester



### SERVICE TIP:

As a general rule, allow up to 0.2 volt per cable and 0.1 volt per connection to be dropped. Switches can be as high as 0.3 volt. Use the wiring diagram for the vehicle to determine the number of conductors and connections used in the circuit. This will provide a specification for you if no other specifications are available.



### SPECIAL TOOLS

Voltmeter  
Fender covers

## Insulated Circuit Resistance Test

An electrical resistance will have a different pressure or voltage on each side of the resistance. Voltage is dropped when current flows through resistance. Most manufacturers design their starting systems to have very little resistance to the flow of current to the starter motor. Most have less than 0.2 volt dropped on each side of the circuit. This means the voltage across the starter input terminal to the starter ground should be within 0.4 volt of battery voltage (Figure 6-10).

Voltage drops are measured by connecting a voltmeter in parallel with the circuit section being tested. In order to obtain a voltage drop reading, a load on the circuit must be applied. The following is a typical test procedure:

1. Connect the test leads as shown (Figure 6-11), depending on the type of system being tested. Usually the positive lead of the voltmeter is connected to the positive battery post and the negative lead is connected to the starter battery (BATT) terminal.
2. Disable the ignition system as discussed in current draw testing.
3. Crank the engine for 15 seconds and observe the voltmeter scale.

This tests for voltage drop in the entire circuit, so if voltage drop is excessive, the cause of the drop must be located. To locate the cause of the excessive voltage drop, move the voltmeter lead on the starter toward the battery. Check each connection while moving toward the battery. With each move of the test lead, crank the engine while observing the voltmeter reading. Continue to test each connection until a noticeable decrease in voltage drop is detected. The cause of the excessive voltage drop will be located between that point and the preceding point.

## Ground Circuit Test

A ground circuit test is performed to measure the voltage drop in the ground side of the circuit (Figure 6-12). If the starter motor connection to ground is broken or loose, the circuit would be opened. This could cause an intermediate starter system problem or a starter motor that will not crank the engine. To perform the ground circuit test, connect the voltmeter

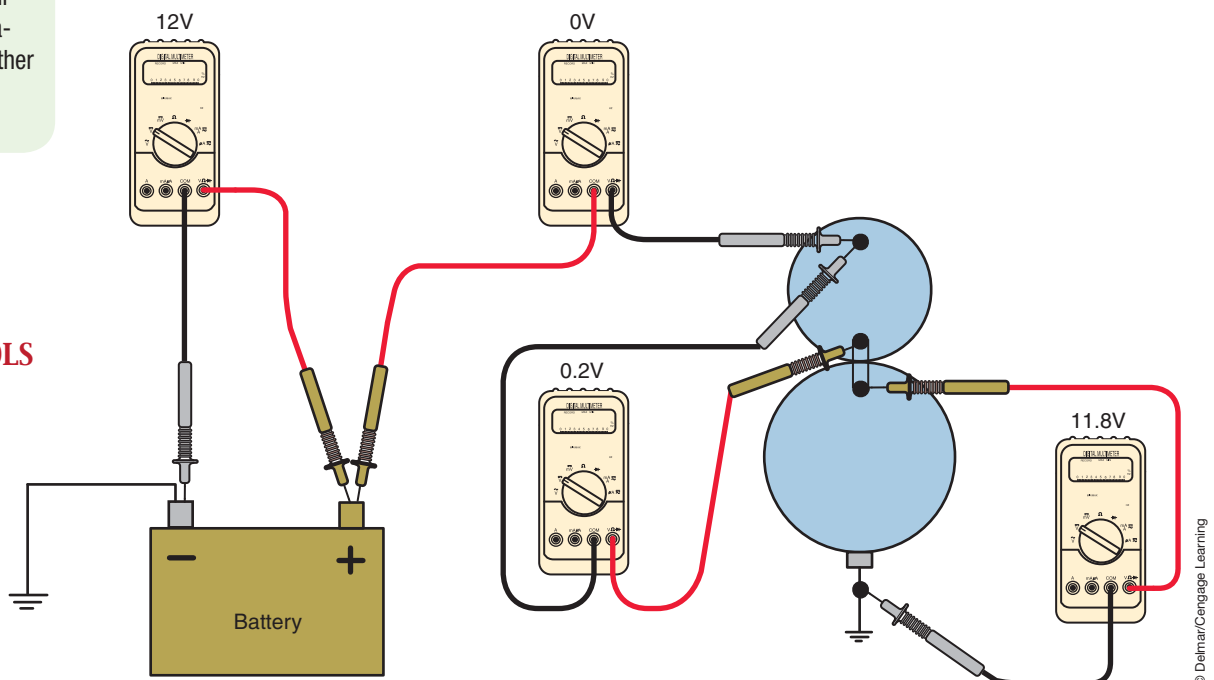
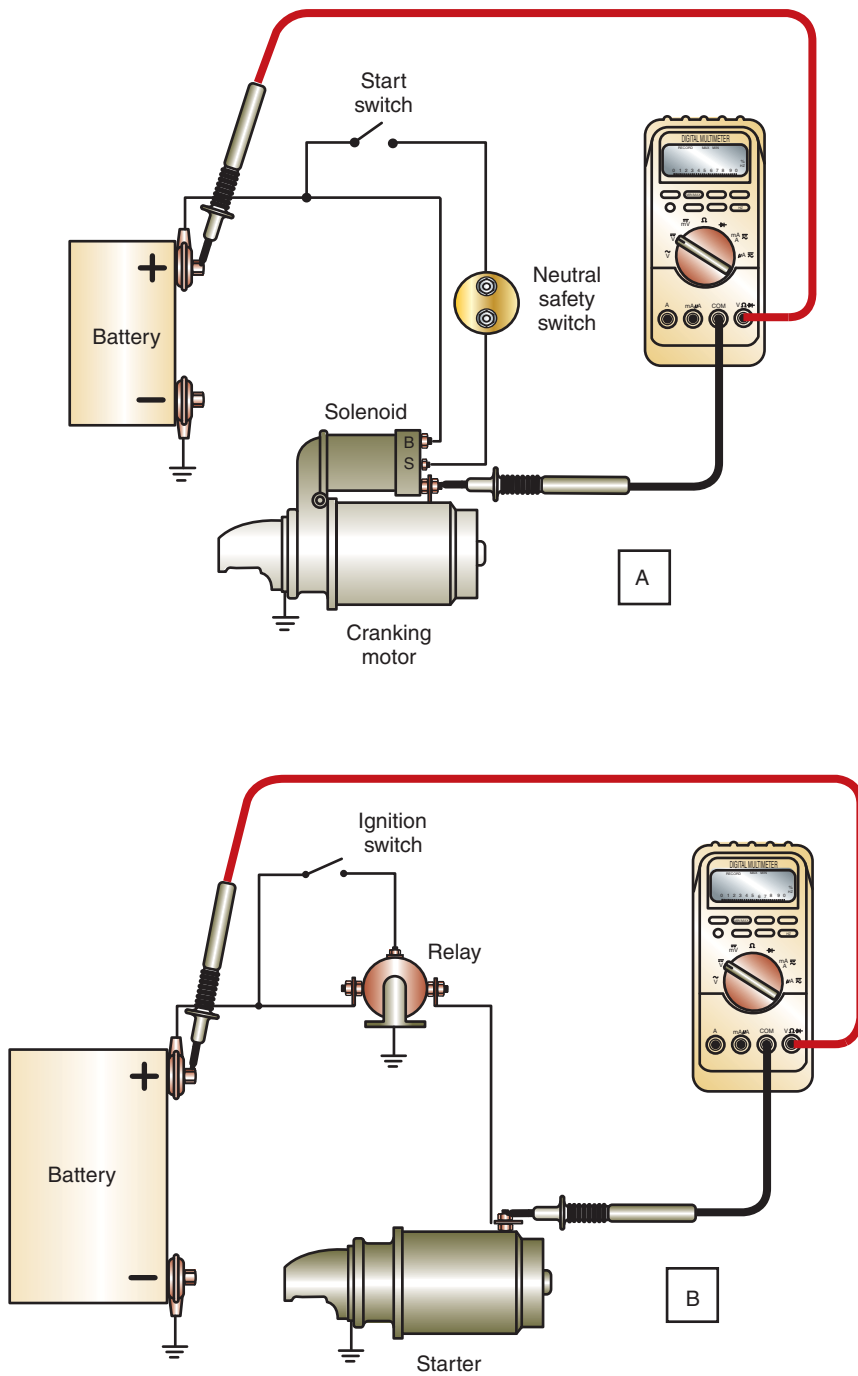


FIGURE 6-10 Voltage drop testing to identify sources of excessive resistance.

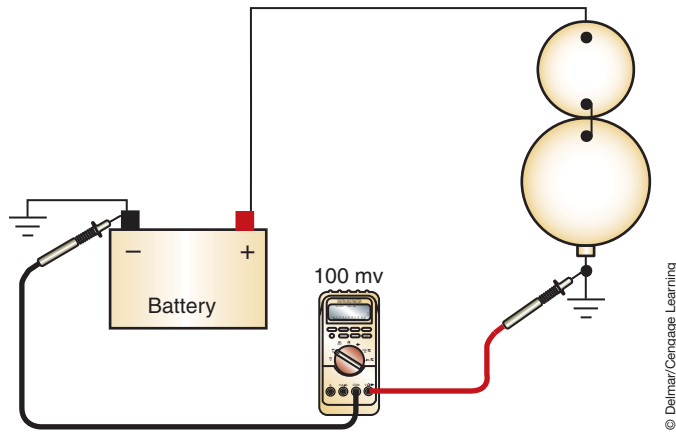


**FIGURE 6-11** (A) Test lead connections for a starter mounted solenoid, (B) test lead connections for relay-controlled systems.

© Delmar/Cengage Learning

positive lead to the starter motor case and the negative test lead to the ground battery terminal. Make sure any paint is removed from the area where the lead is connected to the case. Crank the engine while observing the voltmeter.

Less than 0.2 volt indicates the ground circuit is good. If more than 0.2 volt is observed, then there is a poor ground circuit connection. A poor ground circuit connection could be the result of loose starter mounting bolts, paint on the starter motor case, or a bad battery ground terminal post connection. Also check the ground cable for high resistance or for being undersized.



**FIGURE 6-12** Voltage drop testing of the ground side circuit of the starting system.

© Delmar/Cengage Learning

### Classroom Manual

Chapter 6, page 144



### SPECIAL TOOLS

Voltmeter  
Fender covers  
Starting/charging system tester

## Solenoid Circuit Resistance Testing

High resistance in the solenoid will reduce the current flow through the solenoid windings and cause the solenoid to function improperly. If the solenoid has high resistance in the windings, it may result in the contacts burning and causing excessive resistance to the starter motor.

The **solenoid circuit resistance test** determines the electrical condition of the solenoid and the control circuit. To perform the solenoid circuit resistance test, first disable the ignition system. Using a voltmeter or starting/charging system tester, connect the positive voltmeter lead to the BAT terminal of the solenoid. Connect the negative test lead to the field coil terminal (M terminal). Crank the engine while observing the voltmeter reading. If the voltmeter reading indicates a voltage drop of greater than 0.2 volt, then the solenoid is defective. If this test proves the starter solenoid is good, then the solenoid switch circuit should be tested. Follow these steps:

1. Disable the ignition system.
2. Connect the voltmeter leads to both solenoid switch terminals, observing polarity.
3. Crank the engine and observe the voltmeter reading.

The total voltage drop should be less than 0.5 volt. If the indicated voltage drop is in excess of 0.5 volt, move the voltmeter leads up the circuit and test each component. The voltage drop across each component should be less than 0.1 volt.

Continue to move the voltmeter leads to test for voltage drop through the wires, starter relay, neutral safety switch, and ignition switch.

## Open Circuit Test

In order to perform voltage drop tests, a load must be placed on the circuit. If there is a no-crank complaint, a voltage drop test cannot be performed. Most no-crank problems are the result of opens in the circuit. The easiest way to diagnose this problem is with the use of a test light. On a system that uses a starter motor-mounted solenoid, the M terminal is the end of the circuit (Figure 6-13). Connecting the positive lead of the test light to the M terminal and the negative lead to a good ground, the light should be on when the ignition switch is located in the START position (Figure 6-14). If the light comes on, then the complete insulated circuit (including the ignition switch, wires, neutral safety switch, solenoid, and all connections) is operating properly. The open is in either the starter motor or the ground circuit.

If the test light comes on very dim, then there is very high resistance in the circuit. By working the test light through the circuit and back to the battery, the reason for the high resistance should be found. If the test light did not come on, follow the same procedure of backtracking the circuit toward the battery until the open is found. Also, check for voltage at



### SPECIAL TOOLS

Test light  
Jumper wires  
Fender covers



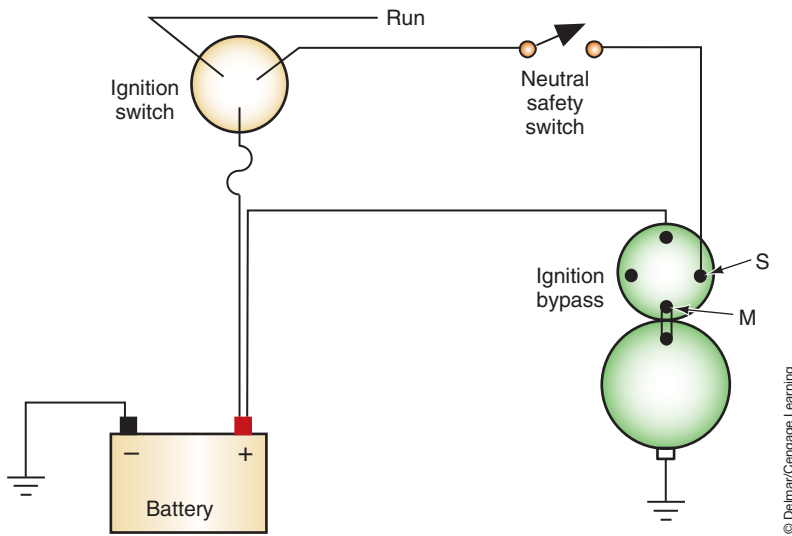


FIGURE 6-13 Starting system using a solenoid shift.

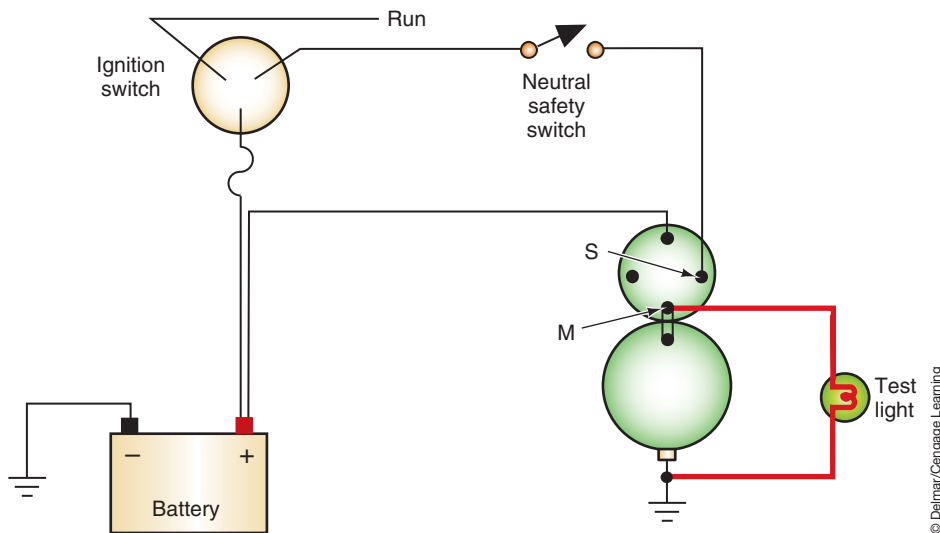


FIGURE 6-14 Test light connections for testing the solenoid and control circuit.



**SERVICE TIP:**  
A Voltmeter can be used in place of the test light. At the M terminal there should be more than 9.6 volts present when the ignition switch is in the START position.

the B+ terminal (Figure 6-15). Connecting the test light as shown should light the bulb with the key off. The light should stay on when the ignition switch is turned to the START position. If the light goes out in the START position, repair the cable or end connections.

Once the open has been found, it can be verified by using jumper wires to jump across the defective component or connection. If jumping across the solenoid, for example, and the starter spins, then there is an open in the solenoid. The same procedure can be used to jump across the ignition switch, neutral safety switch, or open wires.

If the test light did not come on when connected to the M terminal, then make a simple test of the ground circuit. This is done by connecting the ground lead of the test light onto the starter body and the positive lead to the M terminal of the solenoid. The light should come on bright with the ignition switch in the START position. If the ground circuit is good, then the starter is suspect and should be bench tested.

The Ford starting system is tested in the same manner, except there is an additional battery cable to test.



### SERVICE TIP:

Most starter safety switches are adjustable. Sometimes a no-start problem can be corrected by checking and adjusting (or replacing) the starter safety switch.



### SPECIAL TOOLS

Special starter tachometer  
Jumper cables  
Starting/charging system tester  
Remote starter switch  
Soft jaw vise

The free speed test is also referred to as the “no-load test” and the “free spin test.”



### CAUTION:

Failure to load the battery to 10 volts as instructed in step 9 can result in the armature windings being thrown. Because there is no load on the starter, the rpm's will be excessive if more than 10 volts are used.

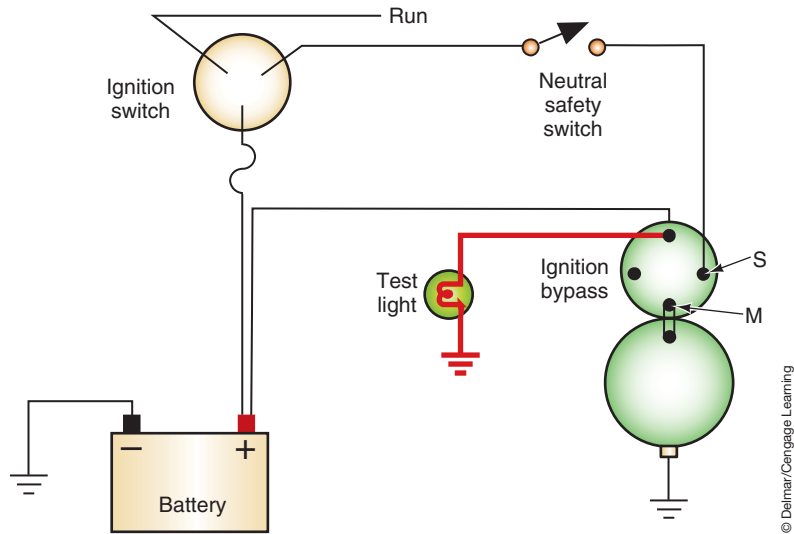


FIGURE 6-15 Test light connections for checking voltage at the BAT terminal.

© Delmar/Cengage Learning

## Free Speed Test

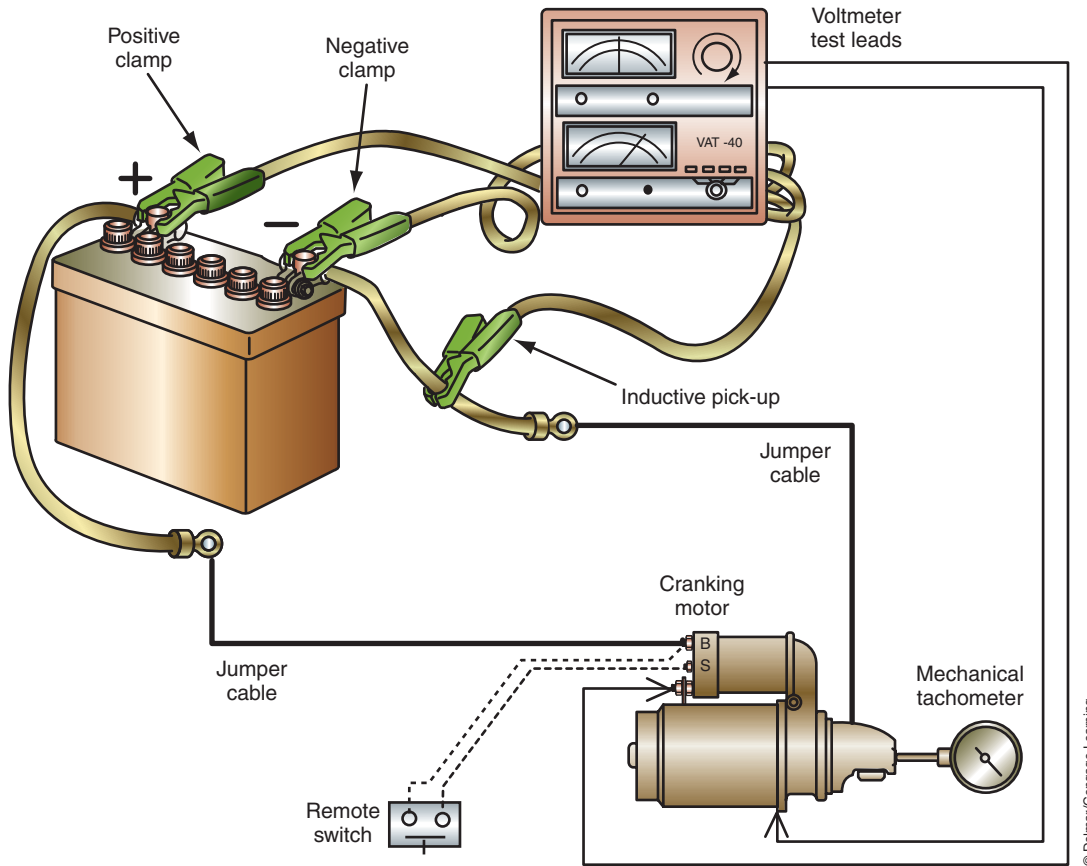
In the event that the starter has failed the previous tests, or a new starter is going to be installed, a **free speed test** should be performed. The free speed test determines the free rotational speed of the armature. Some manufacturers recommend this test procedure over the current draw test. The starter must be removed from the vehicle, as described in the next section. With the starter removed from the vehicle, perform the test as follows (Figure 6-16):

1. Place the starter motor into a secure vise. Be careful not to overtighten the vise against the frame assembly. It is possible to crack the frame and/or the pole shoes.
2. Attach an rpm indicator to the armature shaft at the drive housing end.
3. Connect a remote starter switch between the BAT and S terminals of the solenoid.
4. Connect the jumper cables, as shown in Figure 6-16.
5. Connect the large red and black test leads of the tester across the battery, observing polarity.
6. Follow the manufacturer's instructions for zeroing the ammeter.
7. Connect the amp inductive probe around the jumper cable from the battery negative terminal to the starter frame.
8. Place the test selector to the STARTING position.
9. Load the battery by rotating the load control knob until a voltage reading of 10 volts is obtained.
10. Close the remote starter switch while reading the ammeter, voltmeter, and tachometer scales.

Compare the test results with the manufacturer's specifications. General specifications will be about 6,000 to 12,000 rpm with a current draw of 60 to 85 amperes. Voltage should remain at 10 volts. If the test results are within specifications, the starter motor is ready to be installed into the vehicle.

If the current draw was excessive and rpm slower than specifications, there is excessive resistance to rotation. This could be caused by:

1. Worn bushings or bearings.
2. Shorted armature.
3. Grounded armature.
4. Shorted field windings.
5. Bent armature.



**FIGURE 6-16** Starting/charging system tester connections for a free speed test.

If there was no current draw, and the starter did not rotate, this could be caused by one of the following:

1. Open field windings.
2. Open armature coils.
3. Broken brush or brush spring.

Low armature speed with low current draw indicates excessive resistance. There may be a poor connection between the commutator and the brushes. Also, any connection in the starter and to the starter may be faulty.

If the armature speed and current draw readings are high, check for a shorted field winding.

## STARTER MOTOR REMOVAL

If the tests indicate the starter motor must be removed, the first step is to disconnect the battery from the system. Remove the negative battery cable. It is a good practice to wrap the cable clamp with tape or enclose it in a rubber hose to prevent accidental contact with the battery terminal.

It may be necessary to place the vehicle on a lift to gain access to the starter motor. Before lifting the vehicle, disconnect all wires, fasteners, and so forth, that can be reached from the top of the engine compartment.

**WARNING:** Check for proper pad-to-frame contact after the vehicle is a few inches above the ground. Shake the vehicle. If there are any unusual noises or movement of the vehicle, lower it and reset the pads.

Disconnect the wires leading to the solenoid terminals. To prevent confusion, it is a good practice to use a piece of tape to identify the different wires.



### SPECIAL TOOLS

- Fender covers
- Battery cable puller



### CAUTION:

Special care must be taken when handling the PMGR starter. The permanent magnets are very brittle and are easily destroyed if the starter is dropped or struck by another object.

The shims are used to provide proper pinion-to-ring clearance.

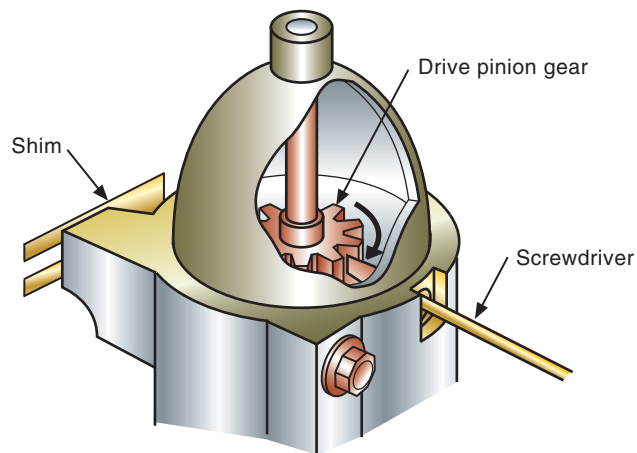
On some vehicles, it may be necessary to disconnect the exhaust system to be able to remove the starter motor. Spray the exhaust system fasteners with a penetrating oil to assist in removal. Loosen the starter mounting bolts and remove all but one. Support the starter motor; remove the remaining bolt. Then remove the starter motor.



**WARNING:** The starter motor is heavy; make sure it is secured before removing the last bolt.

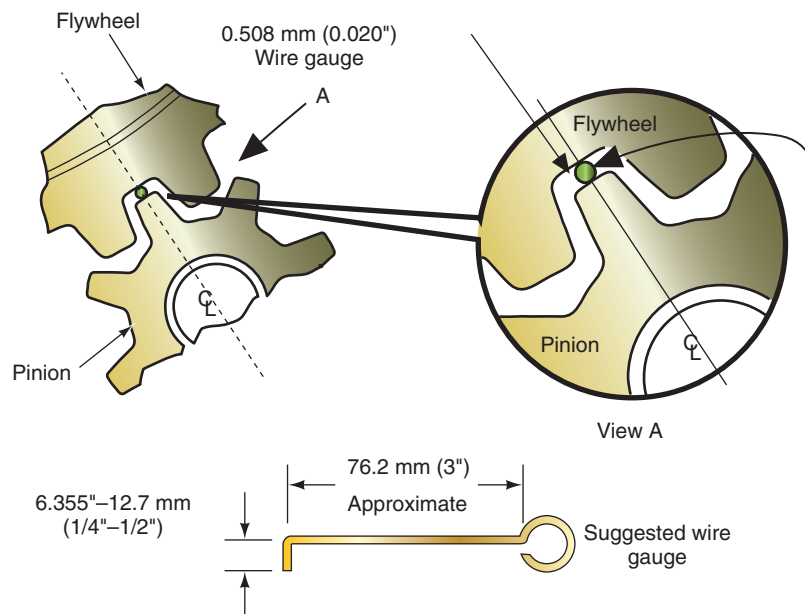
Reverse the procedure to install the starter motor. Be sure all electrical connections are tight. If you are installing a new or remanufactured starter, remove any paint that may prevent a good ground connection. Be careful not to drop the starter. Make sure it is properly supported.

Some General Motors starters use shims between the starter motor and the mounting pad (Figure 6-17). To check this clearance, insert a flat-blade screwdriver into the access slot on the side of the drive housing. Pry the drive pinion gear into the engaged position. Use a piece of wire that is 0.020" in diameter to check the clearance between the gears (Figure 6-18).



One shim will increase clearance by approximately 0.005". More than one shim may be required.

**FIGURE 6-17** Shimming the starter to obtain proper pinion-to-ring gear clearance.



**FIGURE 6-18** Checking the clearance between the pinion gear and ring gear.

If the clearance between the two gears is excessive, the starter will produce a high-pitched whine while the engine is being cranked. If the clearance is too small, the starter will make a high-pitched whine after the engine starts and the ignition switch is returned to the RUN position.

## STARTER MOTOR DISASSEMBLY

If it is determined that the starter is the defective part, it can be disassembled, bench tested, and rebuilt. To reduce vehicle downtime to a minimum, many repair facilities do not rebuild starters. They replace them instead. However, many shops will replace the starter drive mechanism, which may require several of the following disassembling steps. The decision to rebuild or replace the starter motor is based on several factors:

1. What is best for the customer.
2. Shop policies.
3. Cost.
4. Time.
5. Type of starter.

If the starter is to be rebuilt, the technician should study the manufacturer's Service information to become familiar with the disassembly procedures for the particular starter. Photo Sequence 10 illustrates a typical procedure for disassembly of a Delco Remy starter. Always refer to the specific manufacturer's Service information for the starter motor you are working on. The disassembled view of this starter is shown in Figure 6-19.

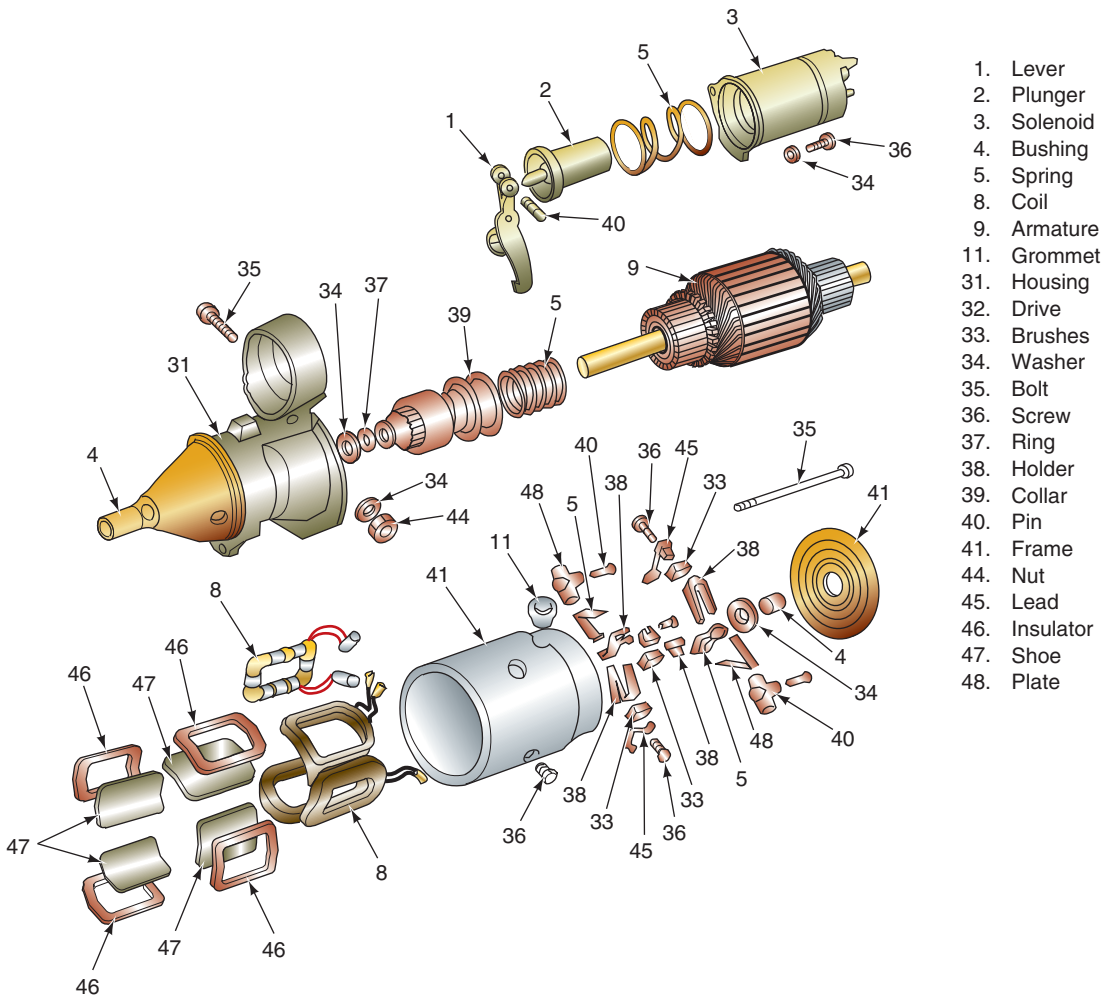


### SERVICE TIP:

The major cause of drive housing breakage is due to too small of a clearance between the pinion and ring gears. It is always better to have a little more clearance than too small of a clearance.

### Classroom Manual

Chapter 6, page 152



1. Lever
2. Plunger
3. Solenoid
4. Bushing
5. Spring
8. Coil
9. Armature
11. Grommet
31. Housing
32. Drive
33. Brushes
34. Washer
35. Bolt
36. Screw
37. Ring
38. Holder
39. Collar
40. Pin
41. Frame
44. Nut
45. Lead
46. Insulator
47. Shoe
48. Plate

FIGURE 6-19 Delco Remy 10MT starter.



# PHOTO SEQUENCE 10

## TYPICAL PROCEDURE FOR DELCO REMY STARTER DISASSEMBLY

All photos in this sequence are © Delmar/Cengage Learning.



**P10-1** Always have a clean and organized work area. Tools required to disassemble the Delco Remy starter: rags, assorted wrenches, snap ring pliers, flat-blade screwdriver, ball-peen hammer, plastic-head hammer, punch, scribe, safety glasses, and arbor press.



**P10-2** Clean the case.



**P10-3** Scribe reference marks at each end of the starter end housings and the frame.



**P10-4** Disconnect the field coil connection at the solenoid's M terminal.



**P10-5** Remove the two screws that attach the solenoid to the starter drive housing.



**P10-6** Rotate the solenoid until the locking flange of the solenoid is free. Then remove the solenoid.



**P10-7** Remove the through bolts from the end frame.



**P10-8** Remove the end frame.



**P10-9** Separate the armature from the frame.





**P10-10** Remove the armature from the drive housing. Note: On some units it may be necessary to remove the shift Clever from the drive housing before removing the armature.



**P10-11** Place a 5/8" deep socket over the armature shaft until it contacts the retaining ring of the starter drive.



**P10-12** Tap end of socket with a plastic hammer to drive the retainer toward the armature. Move it only far enough to access to the snap ring.



**P10-13** Remove the snap ring.



**P10-14** Remove the retainer from the shaft and remove the clutch and spring from the shaft. Press out the drive housing bushing and the end frame bushing.

Photo Sequence 11 illustrates a typical procedure for disassembling a permanent magnet, gear reduction starter. Again, be sure to refer to the specific manufacturer's service information for the starter motor you are working on.

The starter motor can be cleaned and inspected when it is disassembled. Inspect the end frame and drive housing for cracks or broken ends. Check the frame assembly for loose pole shoes and broken or frayed wires. Inspect the drive gear for worn teeth and proper over-running clutch operation. The commutator should be free of flat spots and should not be excessively burned. Check the brushes for wear. Replace them if worn past manufacturer's specifications.

## STARTER MOTOR COMPONENT TESTS

With the starter motor disassembled and the components cleaned, you are ready to perform tests that will isolate the reason for the failure. The armature and field coils are checked for shorts and opens. In most cases, the whole starter motor assembly is replaced if the armature or field coils are bad.



### CAUTION:

Do not clean the starter motor components in solvent or gasoline. The residue left can ignite and destroy the starter. Wipe with clean rags, or use denatured alcohol to clean the starter components.



### SPECIAL TOOLS

- Growler
- Hacksaw blade
- Continuity tester
- Ohmmeter
- Crocus cloth

# PHOTO SEQUENCE 11

## TYPICAL PROCEDURE FOR DISASSEMBLY OF GEAR REDUCTION STARTER

All photos in this sequence are © Delmar/Cengage Learning.



**P11-1** Disconnect the lead to the field coil and remove the solenoid retainer screws.



**P11-2** Remove the solenoid housing while working the plunger off of the drive lever.



**P11-3** Remove the frame through bolts.



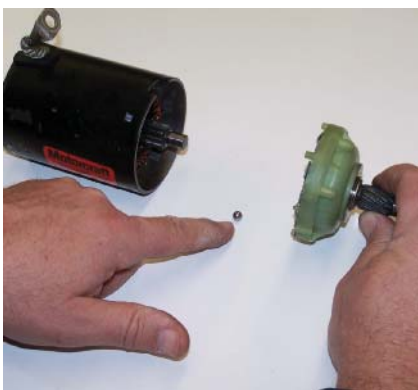
**P11-4** Separate the drive end frame from the body. Remove the seal also.



**P11-5** Remove the O-ring from the end of the drive gear and then remove the retainer ring and C-clip.



**P11-6** Remove the drive from the output shaft.



**P11-7** Separate the output shaft and stationary gear assembly from the armature. Be sure to locate and retain the thrust ball located in a seat in the output shaft.



**P11-8** Remove the lock ring from the output shaft and remove the stationary gear from the shaft.



**P11-9** Remove the planetary gears from the output shaft.



**P11-10** Remove the fasteners that attach the end plate to the brush plate.



**P11-11** Remove the armature and brush assembly from the body.



**P11-12** Separate the brush assembly from the armature.

## Field Coil Testing

The field coil and frame assembly should be tested for opens and shorts to ground. In most cases, if one of these conditions is found, the starter is considered unbuildable in the field and will need to be replaced with a new unit.

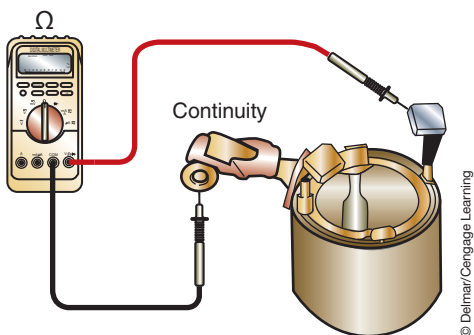
Field coils can be wired in a number of different ways. The most effective testing of the coils for opens and shorts is determined by how the coils are wired. There are two things to do to determine the best way to check the field coils: refer to a Service information for specific instructions and/or refer to the wiring diagram for the starting circuit. By looking at the wiring diagram, you will be able to tell where the coils get their power and where they ground. Knowing these things is critical to testing the coils. The following procedure is valid for many, but not all, vehicles.

Using an ohmmeter, place one lead on the starter motor input terminal. Connect the other lead to the insulated brushes (Figure 6-20). The ohmmeter should indicate zero resistance. If there is resistance in the field coil, replace the coil and/or the frame assembly.

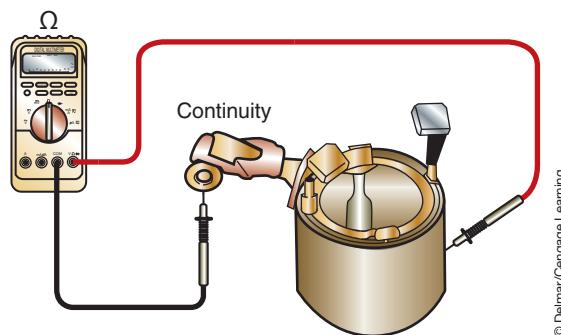
Place one lead of the ohmmeter on the starter motor input terminal and the other lead to the starter frame (Figure 6-21). An infinite reading should be obtained. If the ohmmeter indicates continuity, there is a short to ground in the field coil.

**Classroom Manual**

Chapter 6, page 137



**FIGURE 6-20** Testing the field coils for opens.



**FIGURE 6-21** Testing the field coils for shorts to ground.



**Crocus cloth** is used to polish metals. While polishing, it removes very little metal.

## Armature Short Test

A growler produces a very strong magnetic field that is capable of inducing a current flow and magnetism in a conductor. It is used to test the armature for shorts and grounds (Figure 6-22).

To test the armature for shorts, place the armature in the growler and hold a thin steel blade parallel to the core (Figure 6-23). Slowly rotate the armature and observe the steel blade. If the blade begins to vibrate or pull toward the core, the armature is shorted and in need of replacement.

## Armature Ground Test

With the armature placed in the growler, use a continuity tester or ohmmeter to check for continuity between the armature core and any bar of the commutator (Figure 6-24). If there is continuity, then the armature is grounded and in need of replacement.

## Commutator Tests

If a growler is not available, the armature commutator can be tested for opens and grounds using an ohmmeter. The commutator should be cleaned with **crocus cloth**. To check for continuity, place the ohmmeter on the lowest scale. Connect the test leads to any two commutator sectors (Figure 6-25). There should be zero ohms of resistance. The armature will have to be replaced if there is resistance.

To test the armature for short to ground, use an ohmmeter and connect one of the test leads to the armature shaft. Connect the other lead to the commutator segments (Figure 6-26). Check each sector. There should be no continuity to ground. The armature will have to be replaced if there is continuity.

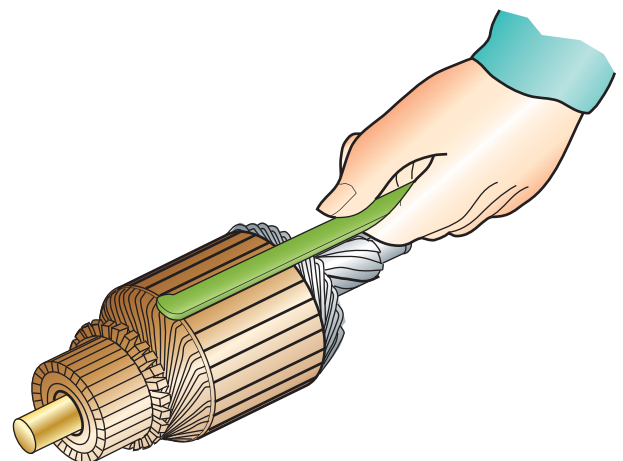
## Brush Inspection

Use an ohmmeter to test continuity through the brush holder (Figure 6-27). Connect one of the test leads to the positive brush and the other test lead to the negative brush. There should be no continuity between the brushes. If the ohmmeter indicated continuity, replace the brush holder.

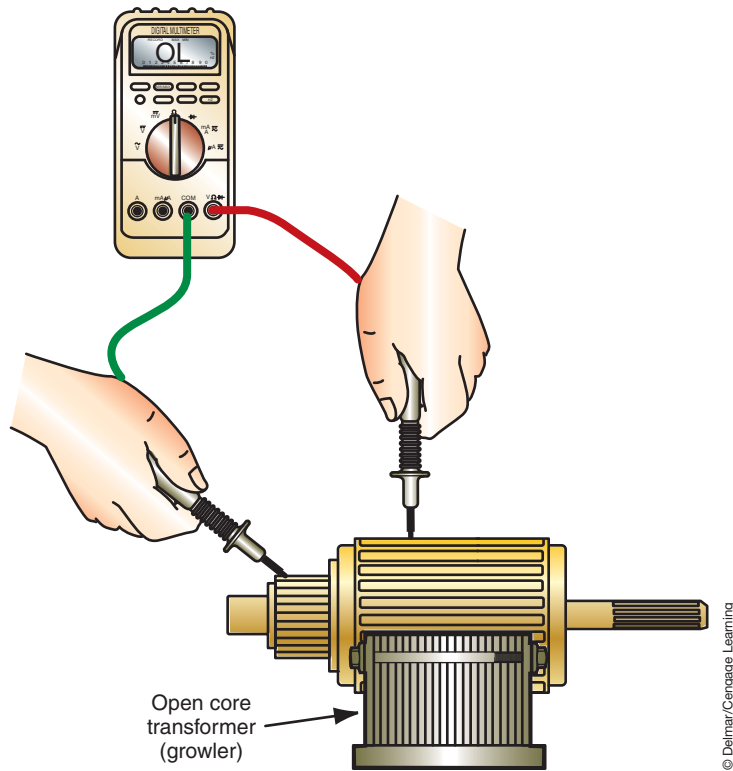
Another check of the brush assembly requires checking spring tension. To do this, install the brushes into the brush holder and slide the assembly over the commutator. Use a spring scale to measure the spring tension of the holders at the point where the spring lifts off the brush. If the spring tension is below specifications, replace the springs or the brush holder assembly.



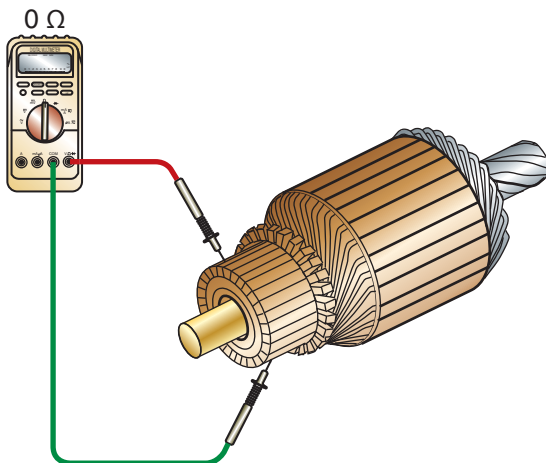
**FIGURE 6-22** A growler is used to test the armature for shorts.



**FIGURE 6-23** The growler generates a magnetic field. If there is a short, the hacksaw blade will vibrate over the area of the short.

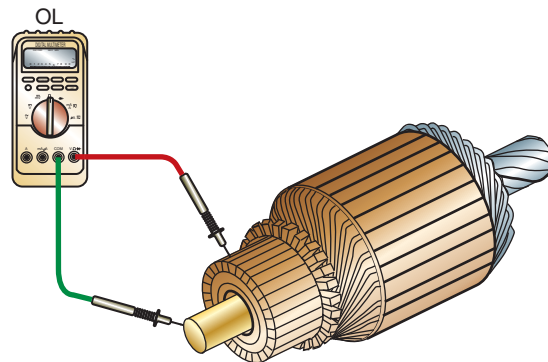


**FIGURE 6-24** Checking an armature for a short.



**FIGURE 6-25** Testing the commutator for opens. There should be zero resistance between the segments.

© Delmar/Cengage Learning



**FIGURE 6-26** Testing the armature for short to ground. The meter should read infinite when placed on the shaft and the different segments of the commutator.

© Delmar/Cengage Learning

Finally, measure the length of each brush (Figure 6-28). If they are shorter than specifications, replace the brushes. Some starters may not have serviceable brushes, thus the brush holder assembly will need to be replaced.

## Overrunning Clutch Inspection

The overrunning clutch may be inspected by sliding it onto the armature shaft. Attempt to rotate the clutch in both directions. If it is working properly, the clutch should rotate smoothly in one direction and lock in the other. If it fails to lock, or locks in both directions, replace the overrunning clutch.

**Classroom  
Manual**

Chapter 6, page 142

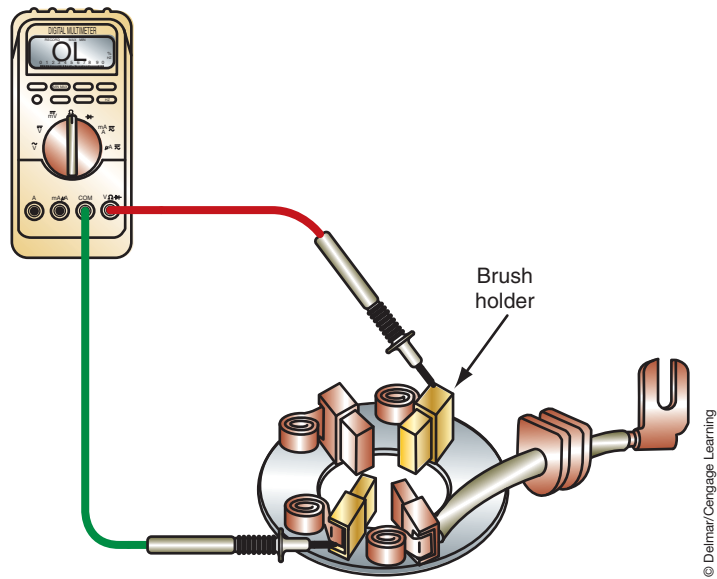
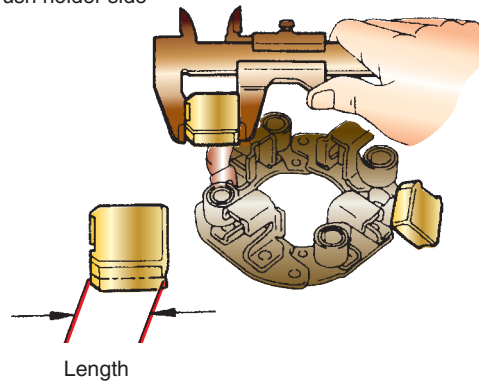


FIGURE 6-27 Typical brush holder.

© Delmar/Cengage Learning

Brush holder side



Field frame side

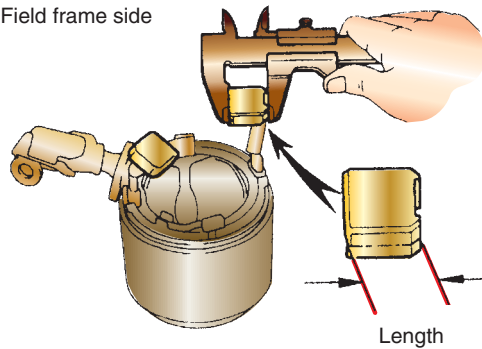


FIGURE 6-28 Measure the length of the brushes to determine if they are worn.

© Delmar/Cengage Learning



### SERVICE TIP:

To seat the new brushes to the commutator, slide the brushes into their holders and then place the assembly onto the commutator. Slide a piece of fine sandpaper between the commutator and the brushes with the grain facing the brushes. Rotate the armature to sand down the face of the brushes so their contour matches the commutator.

## STARTER REASSEMBLY

If the brushes are worn beyond specifications, they must be replaced. Manufacturers use two methods of connecting the brushes; they are either soldered to the coil leads or screwed to terminals.

If the brushes are soldered to the coil leads, cut the old leads (Figure 6-29). Place a piece of heat-shrink tube over the brush connector. Crimp the new brush lead connector to the coil



leads. Solder the brush connector to the coil lead with rosin core solder (Figure 6-30). Slide the heat-shrink tube over the soldered connection and use a heating gun to shrink the tube.

To reassemble the starter motor, basically reverse the disassembly procedures. Additional steps are listed here:

1. With a high-temperature grease, lubricate the splines on the armature shaft that the drive gear rides on.
2. To install the snap ring onto the armature shaft, stand the commutator end of the armature on a block of wood. Position the snap ring onto the shaft and hold in place with a block of wood. Hit the block of wood with a hammer to drive the snap ring onto the shaft (Figure 6-31).
3. Lubricate the bearings with high-temperature grease.
4. Apply sealing compound to the solenoid flange before installing the solenoid to the frame.
5. Use the scribe marks to locate the correct position of the frame-to-frame end and drive housing.



### SPECIAL TOOLS

- Feeler gauge set
- 100-watt soldering iron
- Rosin core solder
- Heat-shrink tube
- High-temperature grease
- Two blocks of wood
- Jumper cables
- Jumper wire
- Starting/charging system tester
- Remote starter switch



FIGURE 6-29 Removing the worn brushes.



FIGURE 6-30 Soldering a new brush to the field coil lead.

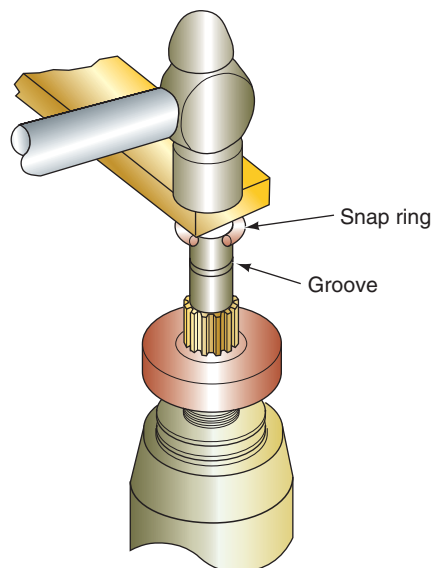
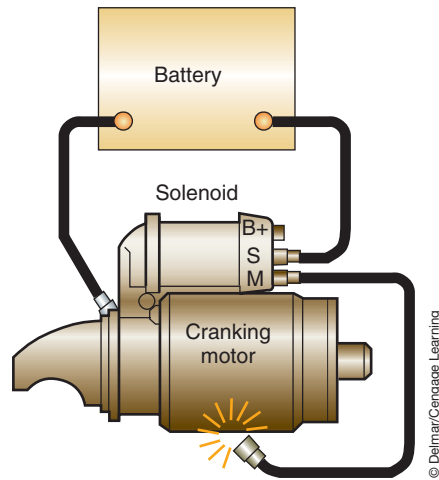
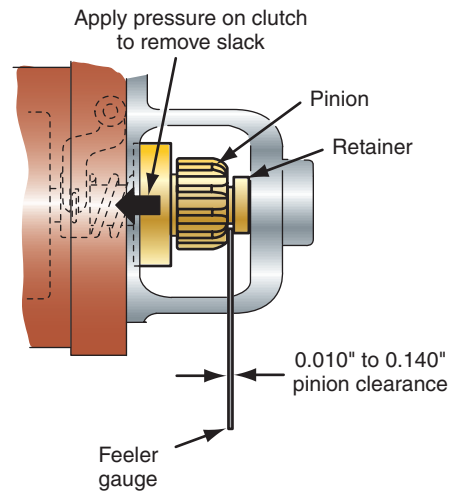


FIGURE 6-31 Once the snap ring is centered on the shaft, a hammer and block of wood can be used to install the ring onto the shaft.



**FIGURE 6-32** Jumper cable connections for checking the pinion gear clearance.



**FIGURE 6-33** Checking the pinion gear to drive housing clearance.



### SERVICE TIP:

There is no provision on most starters to adjust the pinion clearance. However, if the clearance is excessive, it may indicate excessive wear of the solenoid linkage or shift lever.

- Check the pinion gear clearance. Disconnect the M terminal to the starter motor's field coils. Connect a jumper cable from the battery positive terminal to the S terminal of the solenoid. Connect the other jumper cable from the battery negative terminal to the starter frame (Figure 6-32). Connect a jumper wire from the M terminal and momentarily touch the other end of the jumper wire to the starter motor frame. This will shift the pinion gear into the cranking position and hold it there until the battery is disconnected. Once the solenoid is energized, push the pinion back toward the armature; this removes any slack. Check the clearance with a feeler gauge (Figure 6-33). Compare clearance with specifications; normally, specifications call for a clearance of 0.010 to 0.140 inches (0.25 to 0.35 mm).
- Perform the free spin test before installing the starter into the vehicle.

## TERMS TO KNOW

- Crocus cloth
- Current draw test
- Free speed test
- Hydrostatic lock
- No crank
- Quick test
- Relative compression testing
- Slow cranking
- Solenoid circuit-resistance test

## CASE STUDY

A customer has a vehicle towed to the service center because it does not start. The technician verifies the complaint and observes that the starter drive engages the flywheel, but the engine does not rotate. By turning the crankshaft, the technician checks that the engine is able to rotate. The engine turns freely through two complete revolutions.

Next, the technician performs a visual inspection of the starting system. All connections are cleaned and tightened. A complete battery service

is performed to confirm good battery condition. The battery passes all tests. The technician performs the solenoid circuit-resistance test and it indicates an excessive voltage drop as a result of burned contacts. The solenoid is replaced and the repair verified before returning the vehicle to the owner. The extra resistance caused by the burned contacts prevented sufficient current flow to the starter motor. This did not allow enough torque to be generated to rotate the engine.

## ASE-STYLE REVIEW QUESTIONS

1. The starter circuit shown in Figure 6-34 has a fully charged battery. The starter relay and solenoid do not operate when the ignition switch is placed in the START position.

*Technician A* says this could be caused by a grounded circuit at terminal 85 of the starter relay.

*Technician B* says this could be caused by an open to terminal 86 of the starter relay.

Who is correct?

- A. A only                      C. Both A and B  
 B. B only                      D. Neither A nor B
2. Pinion gear to ring gear clearance is being discussed.  
*Technician A* says if the clearance is excessive, the starter will produce a high-pitched whine while the engine is being cranked.  
*Technician B* says if the clearance is too small, the starter will make a high-pitched whine after the engine starts.  
 Who is correct?
- A. A only                      C. Both A and B  
 B. B only                      D. Neither A nor B

3. A 600-millivolt drop is measured across the starter motor solenoid while the engine is being cranked. What is the repair?
- A. Replace the battery.  
 B. Replace the starter motor.  
 C. Confirm cable connections.  
 D. All of the above.
4. In the starter system shown in Figure 6-34, a voltmeter indicates battery voltage to the input of the neutral safety switch and battery voltage on the output terminal with the transmission in neutral and the ignition switch in the START position. This indicates:
- A. Normal operation.  
 B. The neutral safety switch is working properly.  
 C. A faulty starter relay coil winding.  
 D. An open neutral safety switch ground.

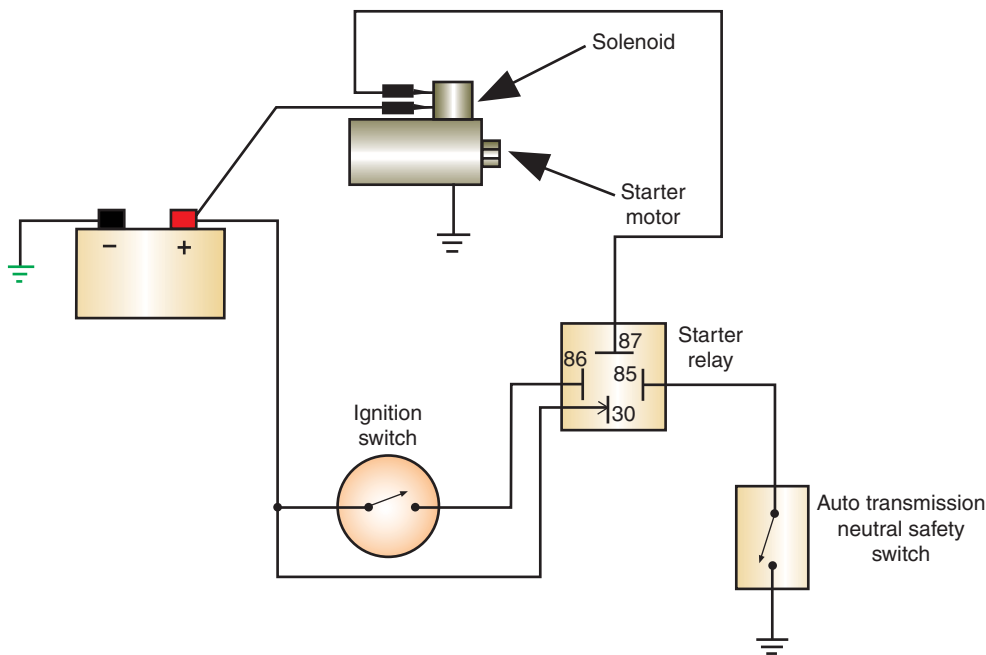


FIGURE 6-34 Starter circuit.

© Delmar/Cengage Learning

5. During a starter current draw test, the voltage is 10.2 volts and amperage is above specifications. This could be caused by all of the following EXCEPT:
- Excessive circuit resistance.
  - Shorted starter windings.
  - Worn starter motor bushings.
  - Internal engine failure.
6. Armature testing is being discussed.  
*Technician A* says to test for shorts, place the armature in the growler and hold a thin steel blade parallel to the core and watch for blade vibrations that would indicate a short.  
*Technician B* says there should be zero resistance between the commutator sectors and the armature shaft.  
 Who is correct?
- A only
  - B only
  - Both A and B
  - Neither A nor B
7. *Technician A* says it is important that a full battery test series be done before trying to test the starter system.  
*Technician B* says the internal condition of the engine has little effect on the operation of the starting system.  
 Who is correct?
- A only
  - B only
  - Both A and B
  - Neither A nor B
8. The starter motor has been rebuilt and is ready to install in the vehicle.  
*Technician A* says to perform the free spin test before installing the starter into the vehicle.  
*Technician B* says to remove the M terminal connector before installing the starter motor.  
 Who is correct?
- A only
  - B only
  - Both A and B
  - Neither A nor B
9. Voltage drop testing of the solenoid control circuit is being discussed.  
*Technician A* says the maximum amount of voltage drop allowed is 0.9 volt.  
*Technician B* says the voltage drop across each wire should be less than 0.1 volt.  
 Who is correct?
- A only
  - B only
  - Both A and B
  - Neither A nor B
10. *Technician A* says most starter noises come from the armature.  
*Technician B* says the starter drive cannot be replaced on most starters.  
 Who is correct?
- A only
  - B only
  - Both A and B
  - Neither A nor B

## ASE CHALLENGE QUESTIONS

1. A vehicle is towed into the shop due to a no-start (no-crank) condition. The headlights are turned on, and when the ignition key is placed in the START position, the lights remain bright but the starter does not crank the engine.  
*Technician A* says that the starter may be binding internally.  
*Technician B* says that the battery may be discharged.  
 Who is correct?
- A only
  - B only
  - Both A and B
  - Neither A nor B
2. A vehicle is being tested for a slow-crank condition. The starter current draw is 525 amps.  
*Technician A* says that the field windings in the starter may be shorted.  
*Technician B* says that the starter drive gear may be slipping.  
 Who is correct?
- A only
  - B only
  - Both A and B
  - Neither A nor B

3. The starter draw of a vehicle with a slow-crank condition is 75 amps. The battery has a good state of charge and it passed a capacity test.

*Technician A* says that a starting circuit voltage drop test should be performed.

*Technician B* says that the neutral safety switch may have excessive resistance.

Who is correct?

- A. A only            C. Both A and B  
B. B only            D. Neither A nor B
4. A voltmeter that is connected across a starter solenoid's battery and motor terminals indicates 12 volts when the ignition key is turned to the START position. A distinct click is heard from the solenoid when this occurs but the engine does not crank.

*Technician A* says that there is excessive voltage drop in the circuit between the battery and the starter solenoid. *Technician B* says that the starter solenoid probably needs to be replaced.

Who is correct?

- A. A only            C. Both A and B  
B. B only            D. Neither A nor B

5. *Technician A* says that incorrect pinion gear to ring gear clearance can result in noisy cranking and high starter draw.

*Technician B* says that starting circuit voltage drop should be checked before performing a starter draw test.

Who is correct?

- A. A only            C. Both A and B  
B. B only            D. Neither A nor B

*This page intentionally left blank*



Name \_\_\_\_\_ Date \_\_\_\_\_

## CURRENT DRAW TEST

Upon completion of this job sheet, you should be able to measure the current draw of a starter motor and interpret the results of the test.

### ASE Correlation

This job sheet is related to the ASE Electrical/Electronic System Certification Exam's content area: *Starting System Diagnosis and Repair*; task: Perform starter current draw test; determine needed repairs.

### Tools and Materials

A vehicle with a 12-volt battery  
 Starting/charging system tester  
 Service information

### Describe the vehicle being worked on:

Year \_\_\_\_\_ Make \_\_\_\_\_ Model \_\_\_\_\_  
 VIN \_\_\_\_\_ Engine type and size \_\_\_\_\_

### Procedure

Task Completed \_\_\_\_\_

1. Perform a battery test series to confirm the battery is good. If necessary, refer to the job sheets in Chapter 5. What was the result of the battery test?  
 PASS \_\_\_\_\_ FAIL \_\_\_\_\_  
 WHY \_\_\_\_\_  
 \_\_\_\_\_
2. Disable the ignition or fuel injection systems to prevent the engine from starting.  
 a. How was this accomplished? \_\_\_\_\_  
 \_\_\_\_\_
3. Expected starter current draw is: \_\_\_\_\_ amps.  
 Voltage should not drop below: \_\_\_\_\_ volts.
4. Connect the starting charging system tester cables to the vehicle.
5. Zero the ammeter on the tester.
6. Be prepared to observe the amperage when the engine begins to crank and while it is cranking. Also, note the voltage when you stop cranking the engine.  
 The initial current draw was: \_\_\_\_\_ amps.  
 After \_\_\_\_\_ seconds, the current draw was \_\_\_\_\_  
 amps and the voltage dropped to \_\_\_\_\_ volts.

Task Completed

7. What is indicated by the test results? Compare your measurements to the specifications.

---

---

---

---

---

□

8. Reconnect the ignition or fuel injection system and start the engine.

Instructor's Response

---

---

---

Name \_\_\_\_\_ Date \_\_\_\_\_

## TESTING THE STARTING SYSTEM CIRCUIT

Upon completion of this job sheet, you should be able to visually inspect the starting circuit and perform voltage drop testing for excessive resistance.

### ASE Correlation

This job sheet is related to the ASE Electrical/Electronic System Certification Exam's content area: *Starting System Diagnosis and Repair*; task: Perform starter circuit voltage drop tests; determine needed repairs.

### Tools and Materials

- A vehicle with a 12-volt battery
- Wiring diagram for the vehicle assigned
- A DMM
- Highlighters

### Describe the vehicle being worked on:

Year \_\_\_\_\_ Make \_\_\_\_\_ Model \_\_\_\_\_  
 VIN \_\_\_\_\_ Engine type and size \_\_\_\_\_

### Procedure

### Task Completed

1. Using the service information, retrieve the wiring diagram for the starting system of the assigned vehicle and print it off. Highlight the positive side of the system in yellow. Highlight the negative side of the system in green. Identify the control circuit with orange. Attach to Job Sheet
  
2. Disable the ignition or fuel injection systems to prevent the engine from starting.
  
3. Connect the voltmeter across the battery's negative cable.  
 Crank the engine with the starter and observe the readings on the meter.  
 Your reading was \_\_\_\_\_ volts.
  
4. What does this indicate?  
 \_\_\_\_\_  
 \_\_\_\_\_  
 \_\_\_\_\_
  
5. Connect the voltmeter across the battery's positive cable (from battery to starter motor). Crank the engine with the starter and observe the readings on the meter.  
 Your reading was \_\_\_\_\_ volts.

6. This test measured the voltage drop across everything in the positive side of the circuit. What is included in this circuit?

---



---



---

7. What do the test results suggest? What are your recommendations?

---



---



---

8. Reconnect the ignition or fuel injection systems to allow the engine to start.

Instructor's Response \_\_\_\_\_

---



---

<b>DIAGNOSTIC CHART 6-1</b>	
PROBLEM AREA:	Starting system operation
SYMPTOMS:	Starter fails to turn engine or operates at reduced efficiency. Excessive current draw.
POSSIBLE CAUSES:	<ol style="list-style-type: none"> <li>1. Shorted armature.</li> <li>2. Worn starter bushings.</li> <li>3. Bent armature.</li> <li>4. Thrown armature windings.</li> <li>5. Loose pole shoes.</li> <li>6. Grounded armature.</li> <li>7. Shorted field windings.</li> </ol>

<b>DIAGNOSTIC CHART 6-2</b>	
PROBLEM AREA:	Starting system operation
SYMPTOMS:	No or reduced starter operation. Current draw too low.
POSSIBLE CAUSES:	<ol style="list-style-type: none"> <li>1. Worn brushes.</li> <li>2. Excessive circuit voltage drop.</li> </ol>

<b>DIAGNOSTIC CHART 6-3</b>	
PROBLEM AREA:	Starting system operation
SYMPTOMS:	Starter fails to rotate the engine or operates at reduced efficiency. Excessive starter circuit resistance.
POSSIBLE CAUSES:	<ol style="list-style-type: none"> <li>1. Excessive starter circuit voltage drop.</li> <li>2. Improper connections.</li> <li>3. Corroded ground connections.</li> <li>4. High resistance in solenoid or relay.</li> </ol>

<b>DIAGNOSTIC CHART 6-4</b>	
PROBLEM AREA:	Starting system operation
SYMPTOMS:	Starter fails to rotate engine or rotates too slowly. Failed starter test series.
POSSIBLE CAUSES:	<ol style="list-style-type: none"> <li>1. Defective or worn starter.</li> <li>2. Worn brushes.</li> <li>3. Shorted field coils.</li> <li>4. Open field coils.</li> <li>5. Shorted armature.</li> <li>6. Open armature.</li> </ol>

<b>DIAGNOSTIC CHART 6-5</b>	
PROBLEM AREA:	Starter control circuit
SYMPTOMS:	Starter does not operate when ignition switch is located in the START position. No sounds.
POSSIBLE CAUSES:	<ol style="list-style-type: none"> <li>1. Open circuit.</li> <li>2. Faulty ignition switch.</li> <li>3. Park/neutral switch faulty or misadjusted.</li> <li>4. Faulty starter relay/solenoid.</li> <li>5. Faulty starter.</li> </ol>

<b>DIAGNOSTIC CHART 6-6</b>	
PROBLEM AREA:	Starter control circuit
SYMPTOMS:	Starter does not operate when ignition switch is located in the START position. Relay/solenoid clicks.
POSSIBLE CAUSES:	<ol style="list-style-type: none"> <li>1. High resistance in starter control circuit.</li> <li>2. High resistance in started circuit.</li> <li>3. Faulty starter relay/solenoid.</li> <li>4. Faulty starter.</li> </ol>

<b>DIAGNOSTIC CHART 6-7</b>	
PROBLEM AREA:	Starter drive
SYMPTOMS:	Starter spins but does not rotate the engine.
POSSIBLE CAUSES:	<ol style="list-style-type: none"> <li>1. Defective one-way clutch.</li> <li>2. Broken teeth on ring gear.</li> <li>3. Faulty starter motor.</li> </ol>

<b>DIAGNOSTIC CHART 6-8</b>	
PROBLEM AREA:	Starter drive fails to disengage after engine starts.
SYMPTOMS:	Excessive noise after engine starts.
POSSIBLE CAUSES:	<ol style="list-style-type: none"> <li>1. Faulty ignition switch.</li> <li>2. Faulty relay/solenoid.</li> <li>3. Faulty starter motor.</li> <li>4. Improper starter mounting.</li> </ol>

*This page intentionally left blank*



## CHARGING SYSTEM TESTING AND SERVICE



### BASIC TOOLS

Basic mechanic's tool set

Service information

### UPON COMPLETION AND REVIEW OF THIS CHAPTER, YOU SHOULD BE ABLE TO:

- Diagnose charging system problems that cause an undercharge or no-charge condition.
- Diagnose charging system problems that cause an overcharge condition.
- Inspect, adjust, and replace generator drive belts, pulleys, and fans.
- Perform charging system output tests and determine needed repairs.
- Perform charging system circuit voltage drop tests and determine needed repairs.
- Perform voltage regulator tests and determine needed repairs.
- Test and replace AC generator diodes and/or rectifier bridge.
- Remove and replace the AC generator.
- Disassemble, clean, and inspect AC generator components.
- Inspect and replace AC generator brushes and brush holders.
- Test and diagnose the rotor.
- Test and diagnose the stator.
- Inspect the HV and LV circuits of the HEV inverter/converter module.

### INTRODUCTION



**WARNING:** Always wear safety glasses when performing charging system tests.

Whenever there is a charging system problem, make sure the battery is thoroughly checked first. The battery supplies the electrical power for the charging system. If the battery is bad, the charging system cannot be expected to work its best. AC generators are designed to maintain the charge of a battery, not to charge a dead battery.

There are many different types of testers that can be used to test the charging system and AC generators. Some handheld multimeters have the ability to conduct many tests. However, the best testers to use are those designed to test the entire system. These testers are commonly referred to as starting/charging system testers. Often, in this chapter, a reference is made to using a VAT-40. This tester, made by Sun Electric Corporation, is commonly found in service departments. Although a VAT-40 is mentioned in the text, this does not mean that this is the only tester that can be used. Any starting/charging system tester can be used. Always follow the operating procedures for the specific tester being used.

When performing the tests, be sure of the connections you are making. Refer to the service information for identification of the various terminals for the AC generator and regulator. Connecting a test lead to the wrong terminal can result in AC generator damage, as well as damage to other electrical and electronic components.



### CAUTION:

Do not overtighten the drive belt. Early bearing failure can occur if the belt is tightened beyond manufacturer's specifications.



### SERVICE TIP:

To check the fusible link to the AC generator, use a voltmeter and test for voltage at the BAT terminal. If the battery is good, voltage should be present. If there is no voltage, the fusible link is probably burned out. A better test would be to measure the voltage drop across the link. This will identify any high resistance in the circuit.

Before attempting to test the charging system, first check the battery. The state of charge must be considered before faulting any of the charging system components. If the battery passes the state of charge test, a load test should be performed to determine the capacity. If the battery fails this test, use a battery charger to fully recharge the battery and test again. It is important that the battery be in good condition in order to obtain accurate charging system test results. In addition, the battery must be fully charged before proceeding with the diagnosis of the charging system.

It is also important to perform a preliminary inspection. Many problems can be detected during this simple step. Check the following items:

1. Condition of the drive belt (Figure 7-1). If the drive belt is worn or glazed, it will not allow enough rotor rpm's to produce sufficient current.
2. Drive belt tension (Figure 7-2).
3. Drive belt tensioner condition.
4. Drive belt tensioner bearing failure.

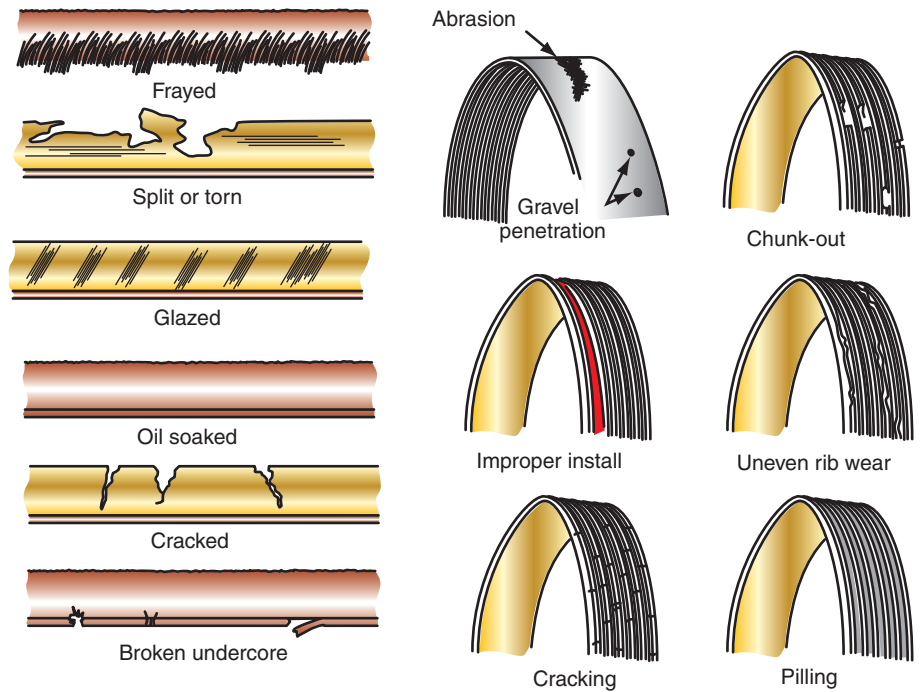


FIGURE 7-1 The generator drive belt must be replaced if any of these conditions exist.



FIGURE 7-2 Checking belt tension using a tension gauge.

5. Electrical connections to the AC generator.
6. Electrical connections to the regulator.
7. Ground connections at the engine and chassis.
8. Battery cables and terminals.
9. Fuses and fusible links.
10. Excessive current drain caused by a light or other electrical component remaining on after the ignition switch is turned off.
11. Symptoms of undercharging. These include slow-cranking, discharged battery, low instrument panel ammeter or voltmeter readings, and charge indicator lamp on.
12. Symptoms of overcharging. These include high ammeter and voltmeter readings, battery boiling, and charge indicator lamp on.

The manufacturer of the vehicle you are working on may have several additional tests to perform. It is important to always follow the procedures outlined by the manufacturer for the vehicle being tested.



**WARNING:** Many charging system tests require that the vehicle be operated in the shop area. Always place wheel blocks against the drive wheels. Be sure there is proper ventilation of the vehicle's exhaust. Also, be aware of the drive belts and cooling fan. Be sure of where your hands and tools are at all times.

## CHARGING SYSTEM SERVICE CAUTIONS

The following are some of the general rules when servicing the charging system:

1. Do not run the vehicle with the battery disconnected. The battery acts as a buffer and stabilizes any voltage spikes that may cause damage to the vehicle's electronics.
2. Do not allow output voltage to increase over 16 volts when performing charging system tests.
3. If the battery needs to be recharged, disconnect the cables while charging.
4. Do not attempt to remove electrical components from the vehicle with the battery connected.
5. Before connecting or disconnecting any electrical connections, the ignition switch must be in the OFF position.
6. Avoid contact with the BAT terminal of the AC generator while the battery is connected. Battery voltage is always present at this terminal.

## AC GENERATOR NOISES

Noises that come from the AC generator can be from three sources. The causes of the noises are identifiable by the types of noises they make. A loose belt will make a squealing noise. Check the belt condition and tension. Replace the belt if necessary.

A squealing noise can also be caused by faulty bearings. The bearings are used to support the rotor in the housing halves. To test for bearing noises, use a length of hose, a long screwdriver, or a technician's stethoscope. By placing the end of the probe tool close to the bearings and listening on the other end, any bearing noise will be transmitted so you will be able to hear it. Bearing replacement will require disassembly of the AC generator.



**WARNING:** This test is performed with the engine running. Use caution around the drive belts, fan, and other moving components.

A whining noise can be caused by shorted diodes or stator, or by a dry rotor bearing. A quick way to test for the cause of a whining sound is to disconnect the wiring to the

### Classroom Manual

Chapter 7, page 169



### SERVICE TIP:

With the engine off, rub a piece of bar soap on the pulley surface of the drive belts. Do this one belt at a time until the noise stops. This way you will know which belt is the cause of the noise.

generator, then start and run the engine. If the noise is not there, the cause of the noise is a magnetic whine due to shorted diodes or stator windings. Use a scope to verify the condition of the diodes and stator. If the noise remains, the cause is mechanical and probably due to worn bearings.

## CHARGING SYSTEM TROUBLESHOOTING

Troubleshooting charts assist the technician in diagnosing the charging system. They give several possible causes for the customer complaint. They also instruct the technician in what tests to perform or what service is required.

### VOLTAGE OUTPUT TESTING

Once the visual inspection and preliminary checks are completed, the next step is to perform a **voltage output test**. The voltage output test is used to make a quick determination about whether or not the charging system is working properly. If the charging system is operating correctly, then check for battery drain. The following procedure is for performing the test:

1. Connect the voltmeter across the battery terminals, observing polarity.
2. Connect the tachometer, following the manufacturer's procedure. Alternately, a scan tool can be used to monitor engine speed.
3. With the engine off, record the base voltage value across the battery.
4. Start the engine. Because most AC generators do not produce maximum voltage output until 1,500 to 2,000 engine rpm, the engine speed needs to be brought up to this level.
5. Observe the voltmeter reading. It should read between 13.5 and 14.5 volts.

**If the charging voltage was too high, there may be a problem in the following areas:**

1. Poor voltage regulator ground connection.
2. High resistance in the "sense" circuit between the battery and the PCM or voltage regulator.
3. Short to ground in the field coil control circuit, causing the AC generator to full field.
4. Defective voltage regulator or PCM.
5. Loose or corroded battery cable terminals.

**If the charging voltage was too low, the fault might be:**

1. Loose or glazed drive belt.
2. Discharged battery.
3. Loose or corroded battery cable terminals.
4. Defective AC generator.
5. Defective voltage regulator or PCM.

**If the voltage reading was correct, perform a load test to check the voltage output under a load condition:**

1. With the engine running at idle, turn on the headlights and the heater fan motor to high speed.
2. Increase the engine speed to approximately 2,000 rpm.
3. Check the voltmeter reading. It should increase a minimum of 0.5 volt over the base voltage reading taken previously. Some vehicle manufacturer's specifications require a rise in voltage of 2.5 volts over the base voltage value obtained in step 3 of the test.
4. If the voltage increases, the charging system is operating properly. If the voltage did not increase, perform the following test series to locate the fault.

It is also possible to use the scan tool to diagnose the charging system's output voltage on most late model vehicles. Most PCM controlled charging systems will use a battery voltage sense circuit to determine the state of charge for the battery (Figure 7-3). This circuit is also

#### Classroom Manual

Chapter 7, page 180



#### SPECIAL TOOLS

Voltmeter  
Tachometer  
Scan tool

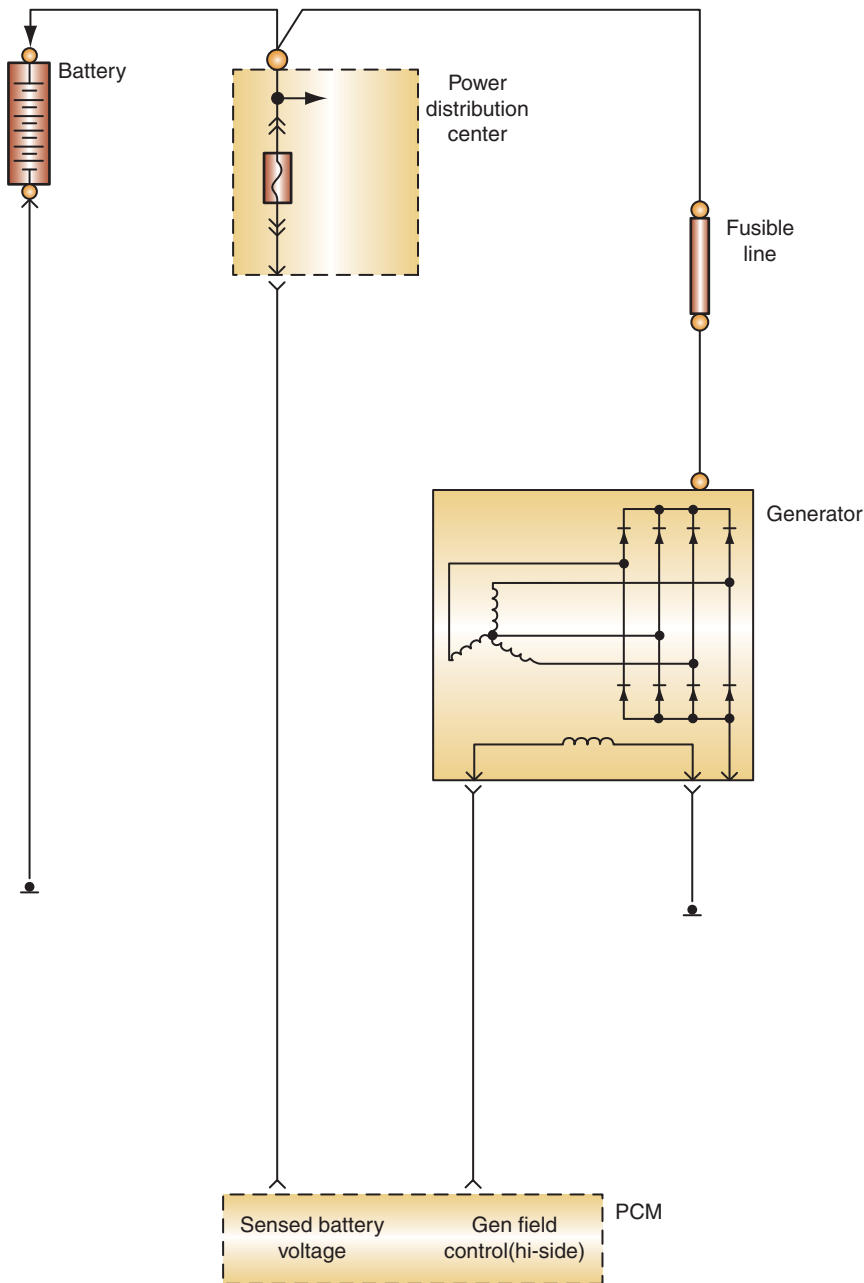


#### SERVICE TIP:

If the charging system passes the no-load test but fails the load test, check the condition and tension of the drive belt closely.

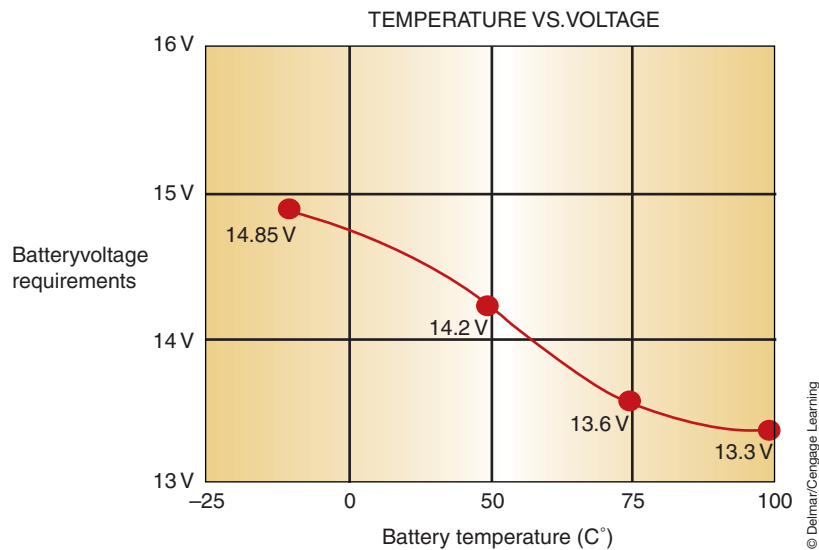
used to determine the output voltage of the AC generator. If the PCM is unable to operate the charging system correctly a diagnostic trouble code (DTC) is set. In this case follow the appropriate diagnostic routine for the set DTC to isolate the cause. However, not all faults result in a DTC. For example, if the sense circuit had excessive resistance due to a poor connection the PCM would increase the generator output until it achieved the desired voltage level. Since the PCM is performing what is believed the correct function, no DTCs are set. However, under this condition the battery would be overcharging.

The PCM will use a temperature sensor to determine the battery temperature. Based on this information it will determine a target voltage for the generator (Figure 7-4). In most cases, the PCM will energize the field circuit until it is about 0.20 volts above the target

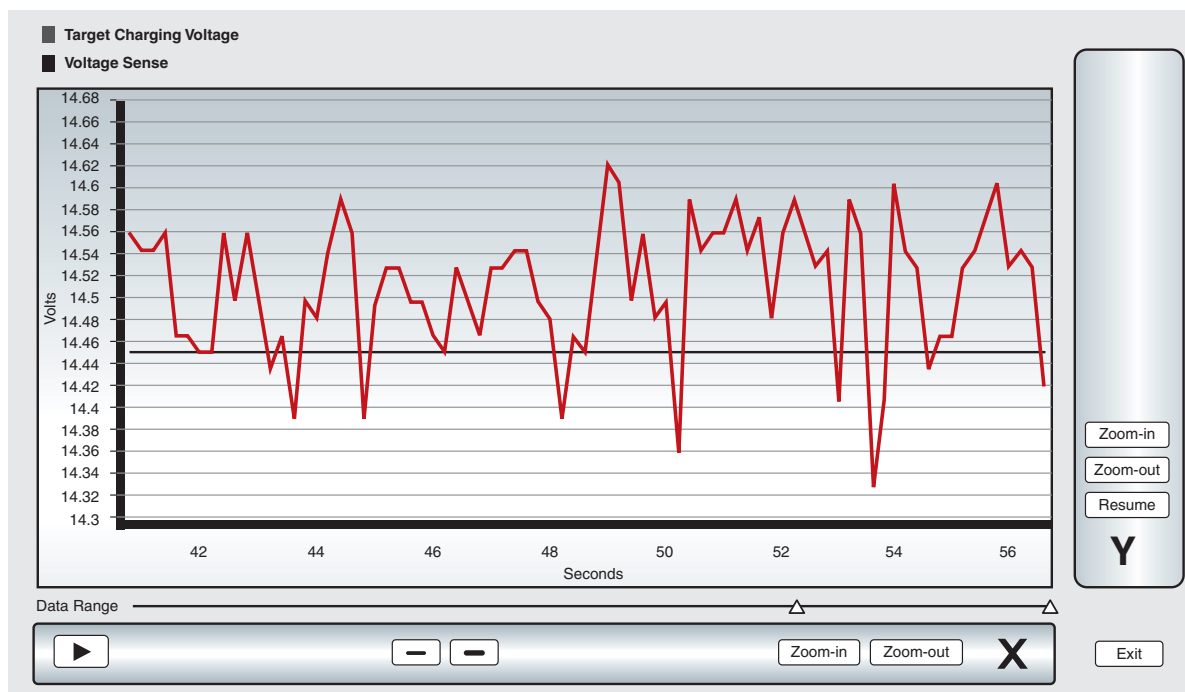


© Delmar/Cengage Learning

**FIGURE 7-3** Computer-controlled charging system will use a sense circuit to monitor the SOC of the battery and the output of the generator.



**FIGURE 7-4** The charging system output voltage is determined by the temperature of the battery.



**FIGURE 7-5** Scan graphing display of target voltage and sensed voltage.



**SERVICE TIP:**

Keep in mind that a faulty temperature sensor or a fault in its circuit can cause the generator to under or overcharge the battery.

voltage then turn off the field current until the voltage drops to a value 0.20 volts below the target voltage (Figure 7-5).

With a voltmeter connected across the battery terminals, compare the scan tool voltage display to the voltmeter reading. If there is a discrepancy between the two readings, the voltage sense circuit needs to be diagnosed.

**VOLTAGE DROP TESTING**

Excessive voltage drop is a primary cause of charging system problems. Testing of all wires and connections should be a part of the diagnostic approach. Any particular wire or connection should not exceed 0.2 voltage drop while the total system drops should be less than 0.7 volt. The ground side voltage drop should be less than 0.2 volt. The **voltage drop test**



determines if the battery, regulator, and AC generator are all operating at the same potential. To perform the voltage drop test using a typical charging system tester, follow these steps:

1. Connect the large red cable to the battery positive terminal.
2. Connect the large black cable to the battery negative terminal.
3. Select CHARGING.
4. Select EXT 3 V.
5. Zero the ammeter.
6. Clamp the inductive pickup around the AC generator output wire.
7. Using the small red and black test leads, connect at the following locations:  
 Insulated circuit: Red lead to AC generator output terminal. Black lead to the battery positive terminal.  
 Ground circuit: Red lead to battery negative terminal. Black lead to AC generator housing.
8. Start the engine and hold the engine speed between 1,500 and 2,000 rpm.
9. Using the carbon pile knob, load the system between 9 and 20 amperes.
10. Read voltmeter.

Some manufacturers recommend measuring voltage drop when the generator is putting out its maximum. Always follow the recommendations of the manufacturer. Remember, if the AC generator is not putting out any current, there will be no voltage drop even if the circuit is very corroded.

**The general specifications for voltage drop testing are:**

- Insulated circuit: less than 0.7 volt.
- Ground circuit: less than 0.2 volt.

If a higher voltage drop is observed, work up the circuit to find the fault. Check every wire and connection.

**Alternate Procedure**

If a starter/charging system tester is not available, the voltage drop test can be performed with just a voltmeter. Simply follow steps 7 through 10 in the previous procedure and turn on the headlights to load the system (Figure 7-6).



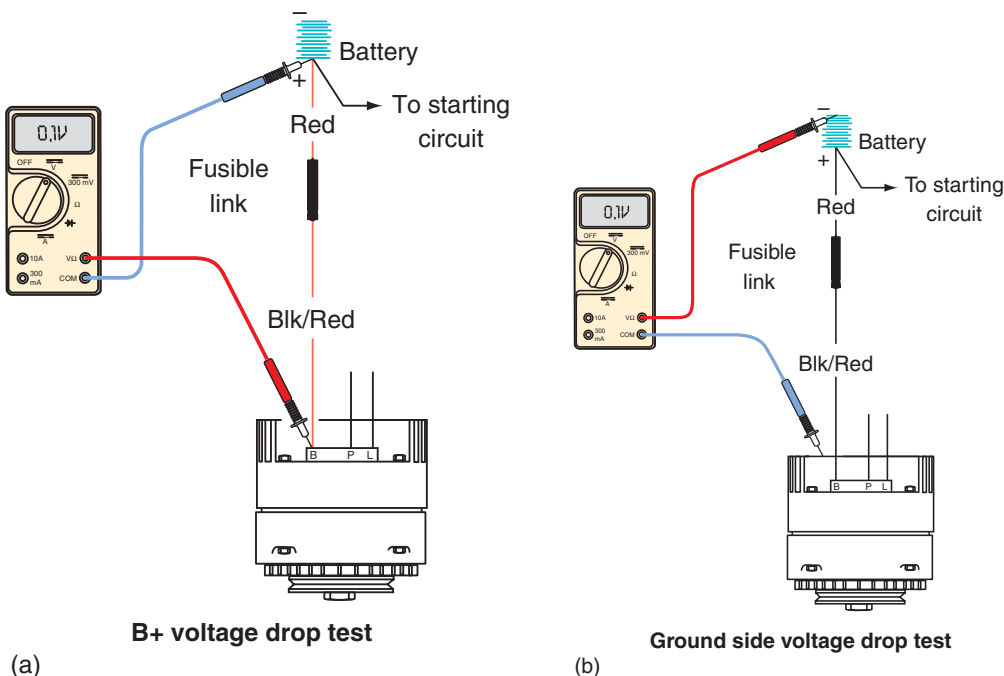
**SPECIAL TOOLS**

- Voltmeter
- Tachometer



**SERVICE TIP:**

Turning on the headlights may be substituted for the carbon pile.



© Delmar/Cengage Learning

**FIGURE 7-6** Voltage drop testing of the generator output circuit (a) and the generator ground circuit (b).



## SPECIAL TOOLS

Starting/charging  
system tester  
Multiplying coil

A **multiplying coil** is made of 10 wraps of wire. This multiplies the ammeter reading so that a starting/charging system tester's scale can be used to read lower current. For example, if the needle is pointing to 25 amperes, when using the multiplying coil, the actual reading is 2.50 amperes.

## FIELD CURRENT DRAW TEST

Because field current is required to create a magnetic field, it is necessary to determine if current is flowing to the field coil. To perform the **field current draw** test using a typical starting/charging system tester, follow these steps:

1. Connect the large red and black cables across the battery, observing polarity.
2. Select CHARGING.
3. Select INT 18 V.
4. Zero the ammeter.
5. Disconnect the field wire from either the AC generator or the regulator.
6. Connect the **multiplying coil** to the field terminal. Make the connection toward the AC generator.
7. Connect the field lead of the tester to the multiplying coil.
8. Clamp the inductive pickup around the loop of the multiplying coil (Figure 7-7).
9. Move the toggle switch to the proper field-type position (A or B).
10. Read the ammeter while the toggle switch is depressed.
11. Compare results with manufacturer's specifications.

For GM, A circuit systems, steps 1 through 4 are the same. Remove the field plug from the AC generator and connect a Y-type connector between terminals 1 and 2. Connect the multiplying coil to the Y connector. Connect the field lead of the tester to the multiplying coil. The inductive pickup is clamped around the loop of the multiplying coil. Press the toggle switch to B (even though an A circuit is being tested) and read the field current draw on the ammeter.

If the readings are within the specification limits, then the field circuit is good. If the readings are over specifications, a shorted field circuit or bad regulator may be the problem. If the readings were too low, then there is high electrical resistance that may be caused by worn brushes.

### To test Ford's integral alternator/regulator (IAR) system, use a voltmeter as follows:

1. With the ignition switch in the OFF position, connect the negative voltmeter lead to the generator housing.
2. Connect the positive voltmeter lead to the F terminal screw of the regulator (Figure 7-8).
3. Check the voltmeter reading. It should indicate battery voltage. If it reads battery voltage, the field circuit is normal.
4. If the voltmeter reading is less than battery voltage, disconnect the wiring plug from the regulator.
5. Connect the positive voltmeter lead to the I terminal of the plug.



© Delmar/Cengage Learning

**FIGURE 7-7** Connecting the multiplying coil and amp pickup to a generator.

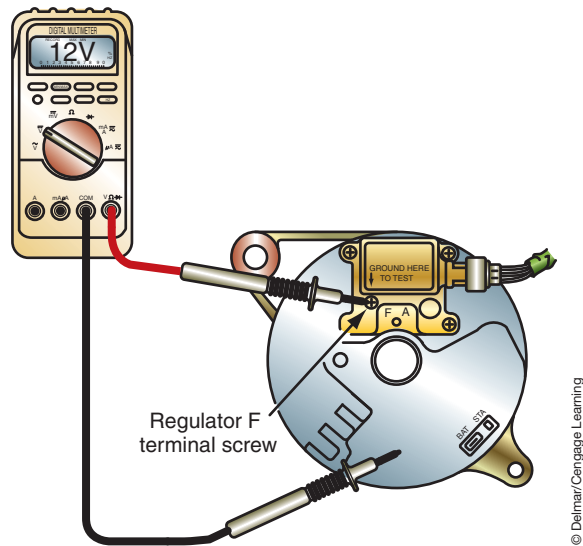


FIGURE 7-8 Testing the IAR generator field circuit.

© Delmar/Cengage Learning

6. Check the voltmeter reading. It should indicate 0 volts. If there is voltage present, repair the I lead from the ignition switch. The I lead is receiving voltage from another source.
7. If there was no voltage present in step 6, connect the positive voltmeter lead to the S terminal of the regulator wiring plug.
8. Check the voltmeter reading. If there are 0 volts, replace or service the regulator.
9. If voltage is indicated, disconnect the wiring plug from the AC generator.
10. Check for voltage to the regulator wiring plug S terminal.
11. If voltage is still present, repair the S terminal wire lead to the AC generator. The S terminal wire is receiving voltage from another source.
12. If no voltage is present, replace the rectifier bridge.

## CURRENT OUTPUT TESTING

The system must be loaded in order to obtain AC generator current output. By connecting a carbon pile to maintain system voltage at 12 volts, the signal voltage to the regulator will be reduced. When this occurs, the regulator attempts to recharge the battery by full fielding. This will produce the maximum current output to the battery. The **current output test** will determine the maximum output of the alternator. Follow the steps in Photo Sequence 12 to perform the current output test.

Once the maximum current output is known, add the maximum output reading to the reading obtained in step 5. This total should be within 10% of the rated output of the AC generator.

If the ammeter reading indicates that output is 2 to 8 amperes below the specification, then an open diode or slipping belt may be the problem. If the output reading indicates 10 to 15 amps below specifications, a shorted diode or slipping belt may be the problem. If the AC generator output is below specifications, perform the full field test.

When testing General Motors CS-130 and 144 AC generators, first use a voltmeter to test for voltage at the L and I terminals. Battery voltage should be indicated at both terminals with the ignition switch in the RUN position.

## FULL FIELD TEST

The **full field test** will determine if the detected problem lies in the AC generator or the regulator. The full field test needs to be performed only if the charging system failed the output test. This test is performed by manually **full fielding** the AC generator with the regulator bypassed. Full fielding means the field windings are constantly energized with full battery

### Classroom Manual

Chapter 7, page 167



### SPECIAL TOOLS

Starting/charging system tester  
Tachometer



### CAUTION:

Not all AC generators can be full fielded. Check the manufacturer's procedures before attempting to full field an AC generator.

# PHOTO SEQUENCE 12

## PERFORMING THE CURRENT OUTPUT TEST

All photos in this sequence are © Delmar/Cengage Learning.



**P12-1** Connect the large red and black cables across the battery, observing polarity.



**P12-2** Select CHARGING.



**P12-3** Zero the ammeter.



**P12-4** Connect the inductive pick-up around all battery ground cables.



**P12-5** With the ignition switch in the RUN position, engine not running, observe the ammeter reading. This reading indicates how much current that is required to operate any full time accessories.



**P12-6** Start the engine and hold between 1,500 and 2,000 rpm.



**P12-7** Turn the load knob for the carbon pile slowly, until the highest ammeter reading possible is obtained. Do not reduce battery voltage below 12 volts.



**P12-8** Return the load control knob to the OFF position.



**P12-9** The highest reading indicates maximum current output.



current. Full fielding will produce maximum AC generator output. If this test still produces lower than specified output, the AC generator is the cause of the problem. If the output is within specifications with the regulator bypassed, then the problem is within the regulator.

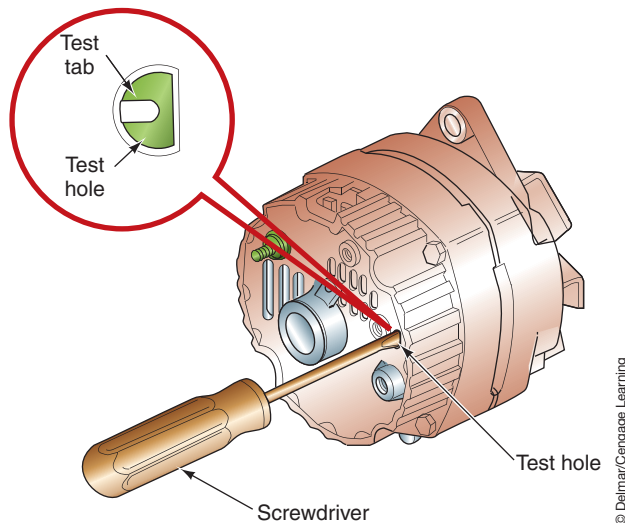
When full fielding the system, the battery should be loaded to protect vehicle electronics and computers. With the voltage regulator bypassed, there is no control of voltage output. The AC generator is capable of producing well over 30 volts. This increased voltage will damage the circuits not designed to handle that high of a voltage.

## General Motors Full Field Testing

To perform the full field test on a GM A circuit SI-type AC generator with an internal voltage regulator, insert a screwdriver into the D-shaped test hole (Figure 7-9). This test hole lines up with a small tab that is attached to the negative brush. By inserting a screwdriver into the D hole about 1/2 in. (12.7 mm) and grounding it to the housing, the regulator is bypassed. Perform the output test again with the regulator bypassed. If the output is within specifications, the regulator is at fault.

A variation of the test calls for shorting the negative brush in the D hole while the ignition switch is in the RUN position. If the brushes and rotor are good, then the rear bearing should be magnetized and attract a metal screwdriver (Figure 7-10).

If the vehicle is equipped with a CS or AD series generator, General Motors does not recommend a manual full field test. Instead, use the current output test to confirm proper operation of the generator.



**FIGURE 7-9** Full fielding the GM 10SI AC generator by grounding the tab in the “D” test hole.



**FIGURE 7-10** Quick check of the rotor and brushes.



### SPECIAL TOOLS

Various jumper wires  
Starting/charging system tester  
Tachometer

### Classroom Manual

Chapter 7, page 193



### CAUTION:

Do not force the screwdriver into the D hole more than 1 in. (25.4 mm). Damage to several electrical systems can result. Do not full field for longer than 10 seconds.



### SERVICE TIP:

If the means of loading the battery is not available, do the full field test for a very short time. Do not allow voltage output to increase over 16 volts. Use the vehicle accessories to put a load on the battery.



**SPECIAL TOOLS**

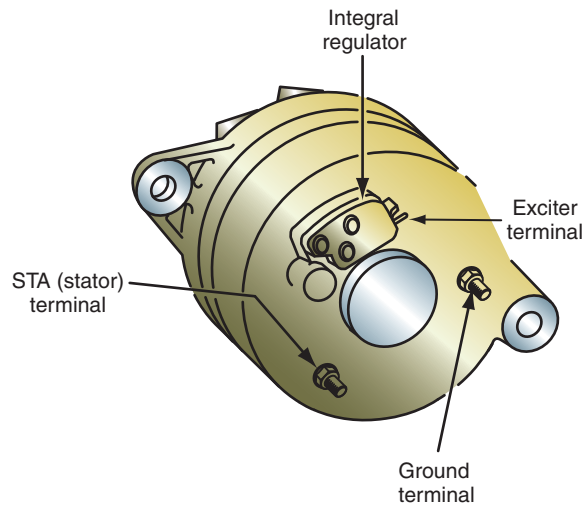
Voltmeter  
Ohmmeter  
Jumper wires

## Ford Full Field Testing

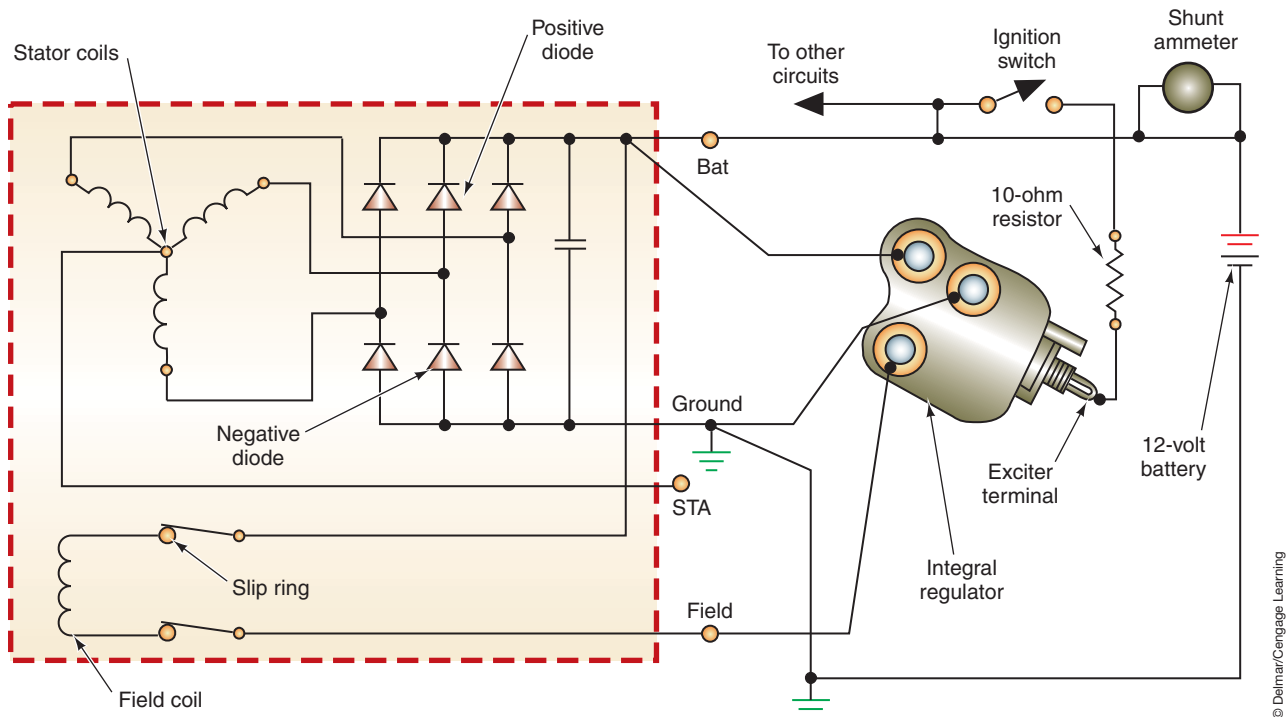
Ford Motor Company has utilized different designs of the integral regulator. The early design had one terminal, called the exciter, which was connected to the outside of the regulator (Figure 7-11). The wiring schematic for this type of design is illustrated (Figure 7-12). By removing the protective cover from the field terminal (closest to the rear bearing), the field circuit can be grounded and the regulator bypassed.

Before full fielding the IAR AC generator, check the rotor and field circuit resistance:

1. Disconnect the wiring plug to the regulator.
2. Connect an ohmmeter between the regulator A and F terminals.
3. Read the ohmmeter. The resistance should not be below 2.4 ohms.



**FIGURE 7-11** Integral regulator with exciter terminal.



**FIGURE 7-12** Wiring schematic of integral regulator with exciter terminal.



If the resistance is less than 2.4 ohms, there is a short to ground somewhere in the circuit. Check for the following:

1. A failed regulator.
2. A shorted rotor circuit.
3. A shorted field circuit.

The illustration (Figure 7-13) shows the wiring of the IAR system. To full field this system, disconnect the wiring connector to the AC generator and install a twelve-gauge wire jumper between the B+ terminal blades (Figure 7-14). Connect another jumper wire from the regulator F terminal screw to ground. Connect a voltmeter with the positive lead connected to one of the B+ jumper wire terminals and the negative test lead to a good ground. Start the engine and perform the load output test. The regulator is faulty if the voltage rises to specifications. If the voltage does not rise to specifications, the AC generator needs to be serviced or replaced.



**CAUTION:**

Do not replace the regulator without first repairing any shorts in the rotor or field circuits. To do so may damage the new regulator.

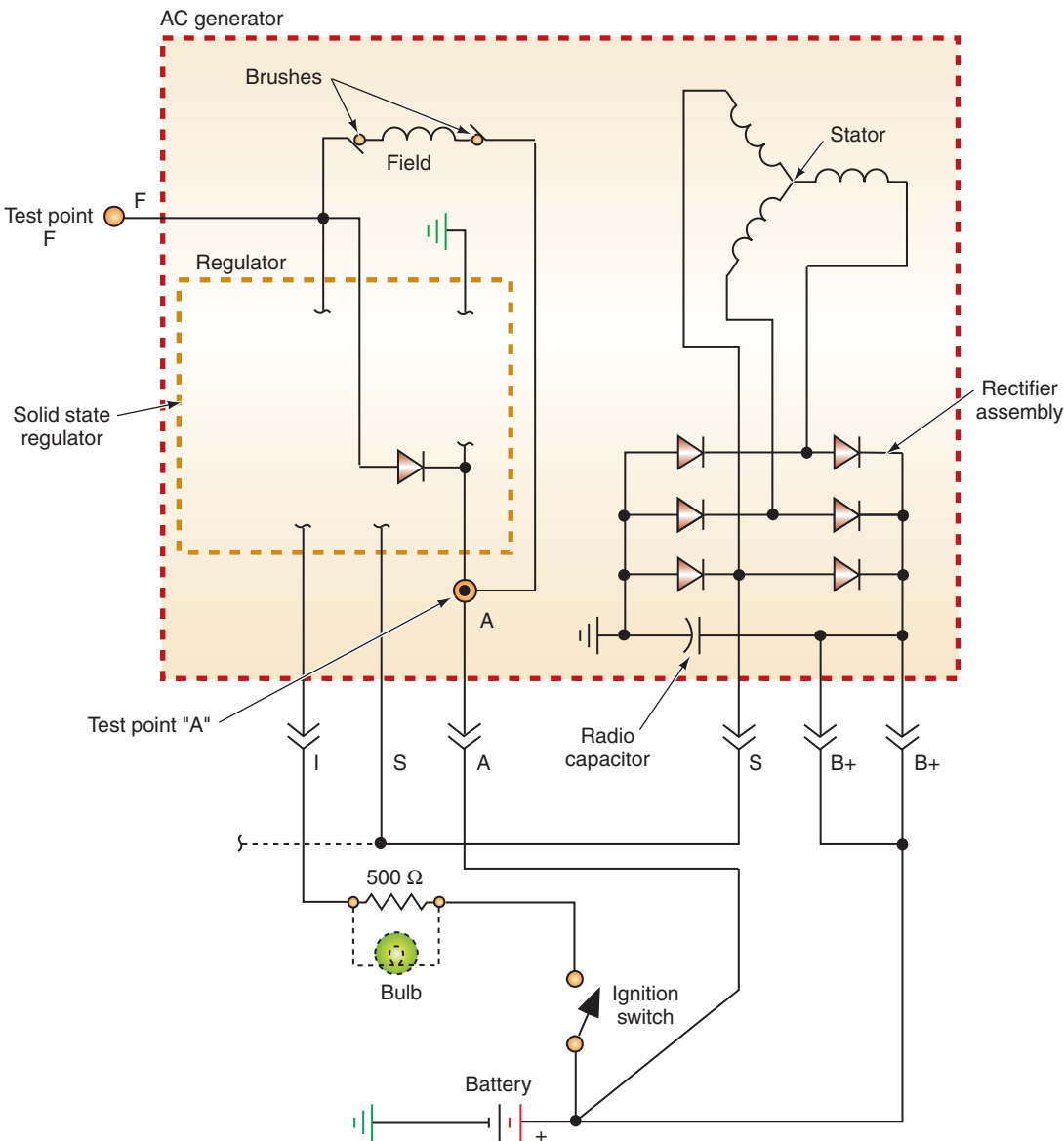


FIGURE 7-13 Wiring diagram of Ford's IAR charging system.

© Delmar/Cengage Learning

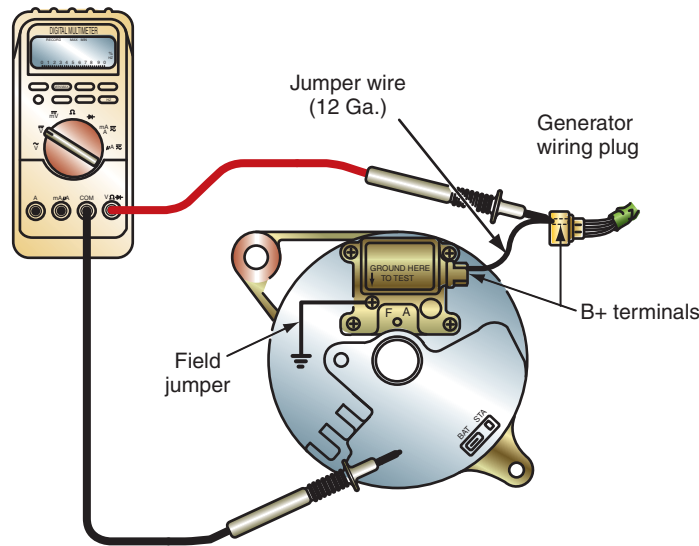


FIGURE 7-14 Jumper wire connections between B+ terminals.

© Delmar/Cengage Learning

### Classroom Manual

Chapter 7, page 196



### CAUTION:

When disconnecting the field wire from the AC generator, be sure the ignition switch is in the OFF position.



### SPECIAL TOOLS

VAT-40 or similar tester  
Scan tool

Some manufacturers with computer-controlled charging systems may provide for onboard diagnostics of the system.

## Chrysler Full Field Testing

Most late-model Chrysler vehicles use an A-type field with the voltage regulator inside the powertrain control module. For Chrysler vehicles with computer-controlled charging systems, refer to the section on “Special Full Field Testing.”

Early Chrysler vehicles used an isolated field with two field leads. To full field these systems, disconnect the green field wire from the AC generator. Then connect a jumper wire from the AC generator field terminal to ground. Start the engine and check the output.

## Special Full Field Testing

Some AC generators that use internal regulators, or computer-controlled regulators, do not provide for a means of full fielding. This can be determined by looking at the wiring diagram for the charging system. In fact, by studying the circuit in the wiring diagram, you should be able to full field any AC generator that can be full fielded. The following procedure uses a starting/charging system tester to full field an AC generator while observing the output of the system. If the AC generator fails this test, it should be repaired or replaced.

### When using the charging system tester, the full field test is performed as follows:

1. Connect the large red and black leads across the battery, observing polarity.
2. Disconnect the field wire from the AC generator.
3. Connect the field test lead from the charging system tester to the field terminal. Make the connection toward the AC generator.
4. Select CHARGING.
5. Select INT 18 V.
6. Zero the ammeter.
7. Clamp the inductive pickup around the AC generator output wire.
8. Turn the ignition switch to the RUN position. Do not start the engine. Record the ammeter reading.
9. Start the engine and hold the speed between 1,500 and 2,000 rpm.
10. Turn the load control knob until the voltmeter reads the voltage specified for maximum output.
11. Read the current output on the 100-amp scale and compare to specifications. If the reading is within specifications, the regulator and AC generator are fine. If the reading is below specifications, continue testing.
12. Release the load control knob and allow the engine to run at 1,500 to 2,000 rpm.
13. Turn the load control knob until the voltmeter indicates 2 volts less than system voltage.

14. Full field the AC generator using the field switch. Use the load control knob to prevent system voltage from exceeding 14 volts.
15. Adjust the load control knob to the voltage reading that is required in the manufacturer's specifications.
16. Read the output on the 100-ampere scale while depressing the toggle switch.
17. Release the field selector switch and return the load knob to the OFF position.
18. Add the reading obtained in step 8 to the reading in step 16. Compare to manufacturer's specifications.

Some manufacturers may provide a method of full fielding the generator using a scan tool (Figures 7-15 and 7-16). The scan tool will direct the PCM to full field the generator and

If the circuit type is unknown, test in both the A and B positions.



**CAUTION:** Check the manufacturer's service information to see if there are instructions that prohibit full fielding the AC generator in this manner. If the AC generator cannot be full fielded, it will have to be disassembled and bench tested.



**CAUTION:** To prevent AC generator damage, do not use the test lead while the regulator is still connected to the system.



**CAUTION:** Always refer to the manufacturer's service information for the correct location of the AC generator terminals. Incorrect test connections can damage the AC generator and the vehicle's electrical system components.

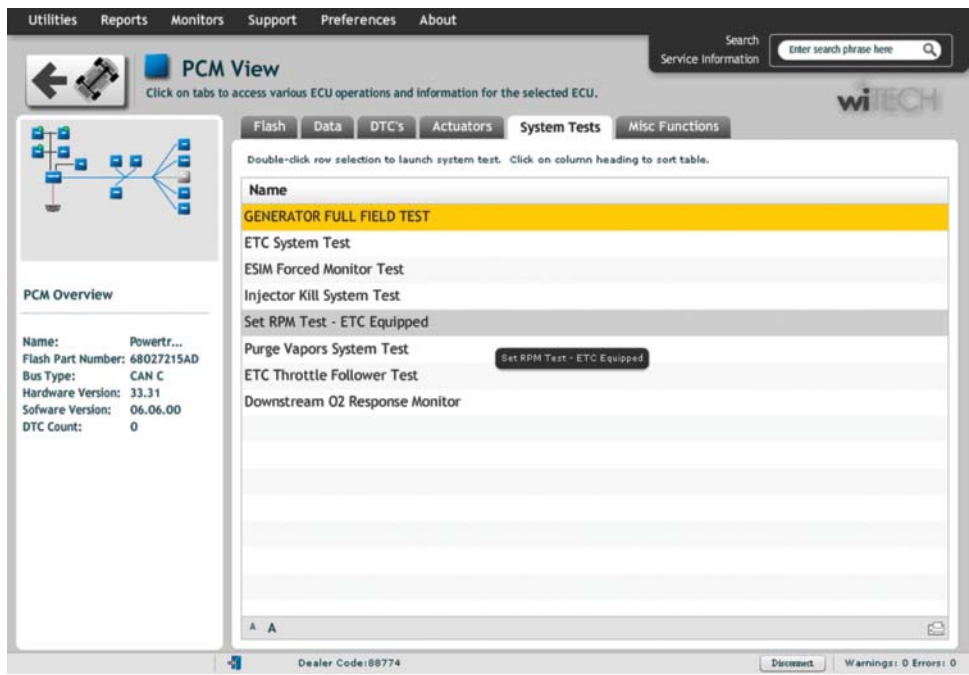


FIGURE 7-15 Some scan tools support an onboard generator full field test.

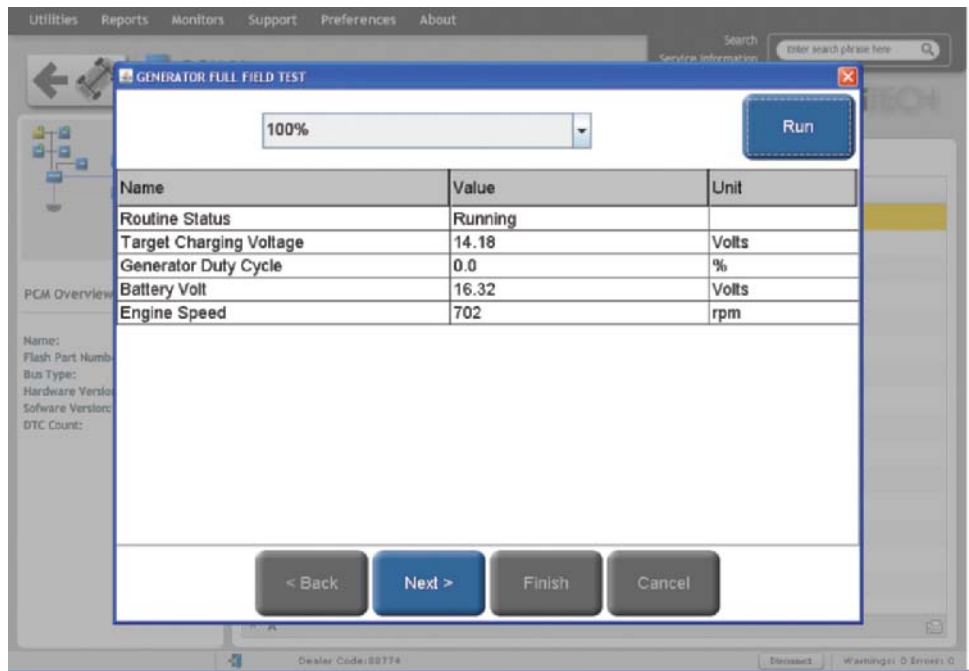


FIGURE 7-16 Running the full field test using a scan tool.

display the sensed battery voltage. While full fielding, the voltage should increase. However, if the voltage does not increase, you still must determine if the fault is in the generator, the insulated side of the field circuit, the field circuit between the generator and the PCM, or the PCM itself.

**AUTHOR'S NOTE:** When using the scan tool to perform the full field test, the PCM is not really bypassed thus it will still control generator output. Because of this the output voltage will not be allowed to increase over a preset limit.

### Classroom Manual

Chapter 7, page 183



### SPECIAL TOOLS

Starting/charging system tester  
Tachometer

## REGULATOR TEST

The regulator test is used to determine if the regulator is maintaining the correct voltage output under different load demands.

**To perform the regulator voltage test using a VAT-40 or similar starter/charging system tester, follow these steps:**

1. Connect the large red and black cables across the battery, observing polarity.
2. Select REGULATOR.
3. Select INT 18 V.
4. Zero the ammeter.
5. Clamp the inductive pickup around the AC generator output wire.
6. Start the engine and hold between 1,500 and 2,000 rpm.
7. Allow the engine to run until the ammeter reads 10 amperes or less. This indicates the battery is fully charged.
8. Voltage should read regulated voltage (13.5–14.5 volts).
9. Load the system to between 10 and 20 amperes.
10. Voltmeter should still read regulated voltage.

### Classroom Manual

Chapter 7, page 171



### SPECIAL TOOLS

Starting/charging system tester  
Tachometer

## DIODE/STATOR TEST

An AC generator may have an open diode yet test close to manufacturer's specifications. If there is an open diode that is not determined in testing, a newly installed regulator may fail. In addition, an open diode can lead to the failure of other diodes. The **diode/stator test** is performed to determine the condition of the diodes. This is performed in the following manner:

1. Connect the large red and black cables across the battery, observing polarity.
2. Select the CHARGING position.
3. Select INT 18 V.
4. Zero the ammeter.
5. Clamp the inductive pickup around all of the negative battery cables.
6. Start the engine and hold between 1,500 and 2,000 rpm.
7. Adjust the load control knob to obtain an indicated charge rate of 15 amperes.
8. Set the selector to the DIODE/STATOR position while observing the red and blue DIODE/STATOR scale.
9. Return the load control knob to the OFF position.

If the meter was in the blue section of the scale, the diodes and stator are good. If the meter was in the red section of the scale, the diodes or the stator is bad. The AC generator will need to be disassembled to perform bench testing of these units.

This test is not valid for AC generators that failed the full field test.

# DIODE PATTERN TESTING

**CUSTOMER CARE:** It is good practice to check the diode pattern of the AC generator anytime an electronic component fails. Because the electronics of the vehicle cannot accept AC current, the damage to the replaced component could have been the result of a bad diode. By performing this check, it is possible to find the cause of the problem.

Set an oscilloscope on the lowest scale available. Connect the primary test leads on the AC generator output terminal and ground. Start the engine and place a moderate load on the charging system (15 to 20 amperes). Different patterns may appear. What is considered normal depends on the load placed on the system.

The diode pattern (Figure 7-17) illustrates a good pattern if the AC generator is under a full load. The pattern shown in Figure 7-18 is a good pattern for some AC generators under a no-load condition.

Patterns that have high-resistance, open, and shorted diodes are illustrated (Figures 7-19 through 7-22). Remember to check the waveforms for noise. If the diodes don't rectify all of the AC voltage, some will ride on the DC output.

An alternate method to test the action and functionality of the diodes is to check for AC voltage at the output terminal of the generator. This can be done with a DMM or a lab scope set on a low AC voltage scale. Connect the positive test lead to the generator's output terminal and the negative test lead to the case of the generator. With the engine running, turn on enough accessories to cause a 10 to 20 amp flow from the generator. Ideally there should be zero volts AC displayed on the meter. A voltage reading greater than 0.250 VAC indicates the diodes are not rectifying the AC output of the generator.

The DMM testing just described looks at the average of the three stator windings. Because of this, if one leg of the stator is beginning to have a problem it may not be indicated by the

Classroom Manual

Chapter 7, page 174



### SPECIAL TOOLS

Oscilloscope  
Carbon pile  
DMM



### SERVICE TIP:

Instead of using a carbon pile, it is possible to place a moderate load on the charging system by turning on the headlights and a few other electrical accessories.

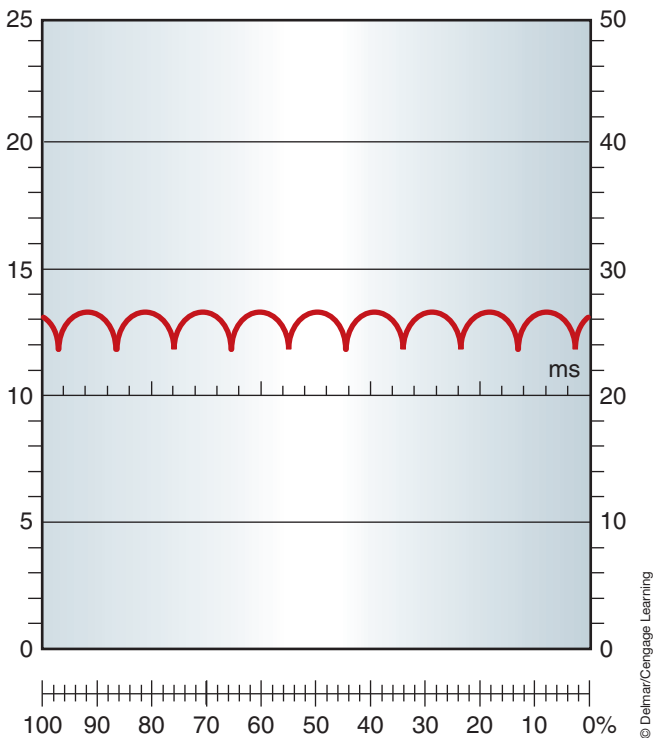


FIGURE 7-17 Good AC level from the generator.

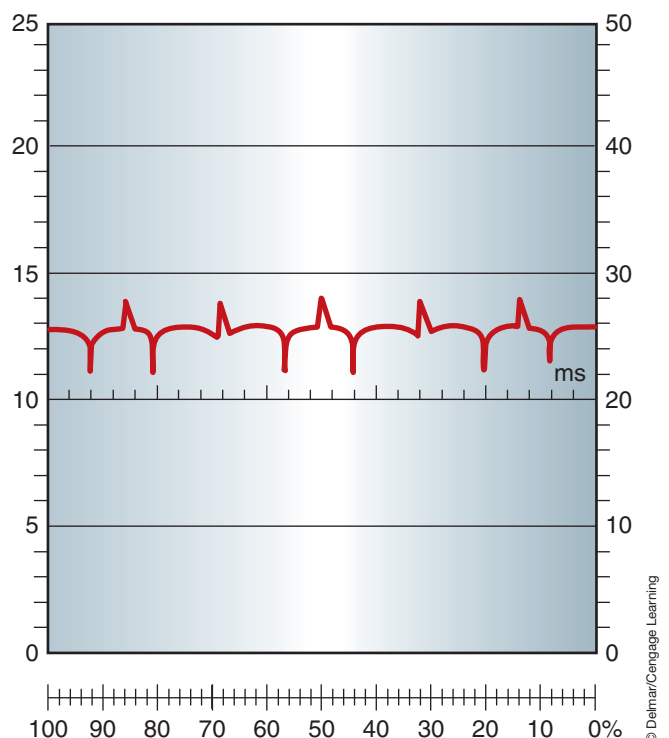
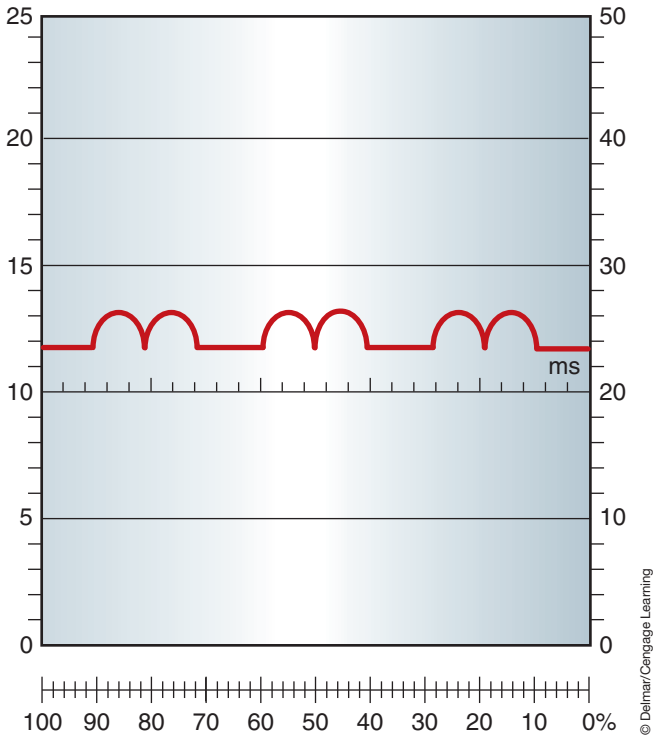
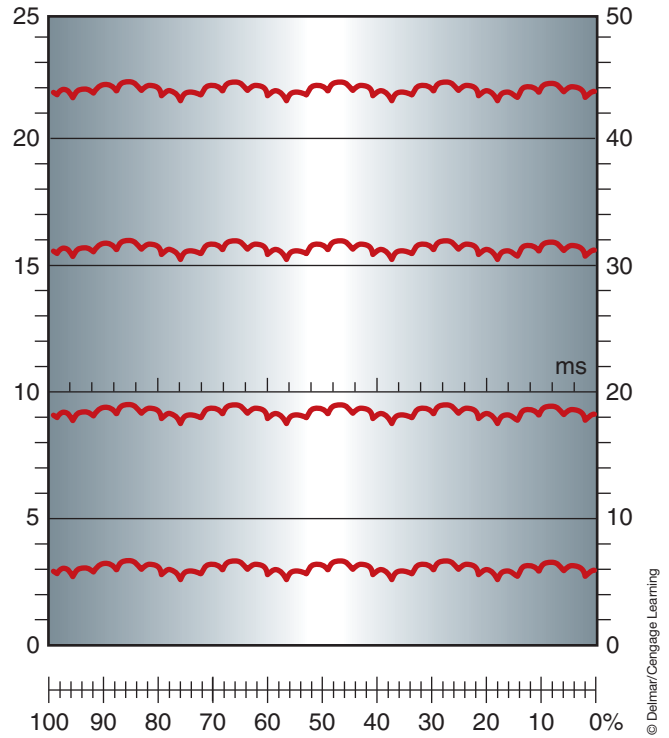


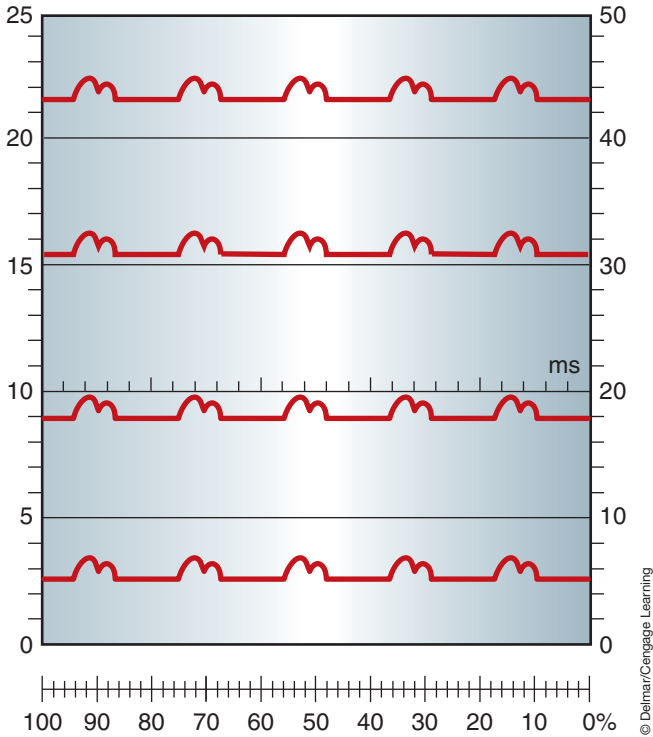
FIGURE 7-18 Excessive AC voltage from the generator.



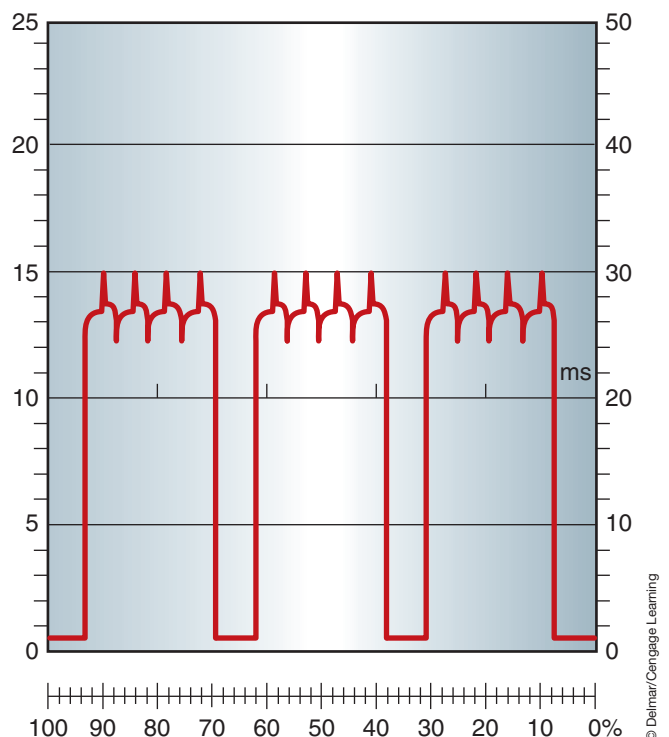
**FIGURE 7-19** Good diode waveform when the AC generator is operating under full load.



**FIGURE 7-20** Good diode waveform when AC generator is operating under no load demands.



**FIGURE 7-21** Shorted diodes or shorted stator winding when the AC generator is placed under full load.



**FIGURE 7-22** A waveform indicating high resistance.



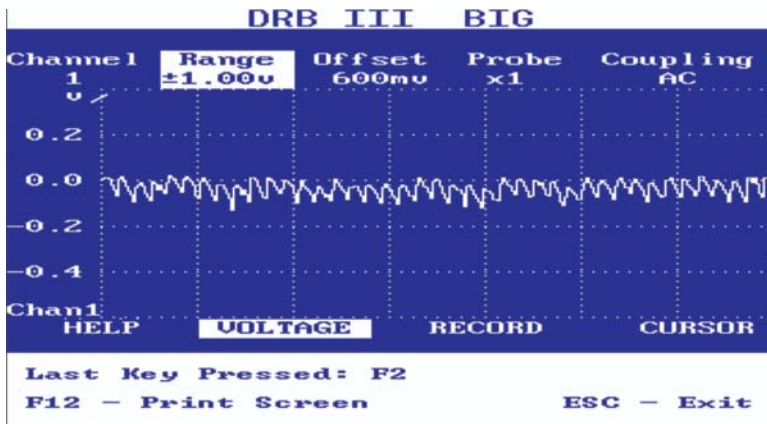


FIGURE 7-23 Waveform pattern indicating one open and one shorted diode.



FIGURE 7-24 Waveform indicating an open diode in the diode trio.

average reading on the DMM. To see what is occurring with each leg, a lab scope is a better choice. A good pattern should not have a voltage over the peak to peak voltage limit of 0.250 VAC (Figure 7-23). Since each voltage pulse is an AC pattern from the generator, excessive AC voltage is easy to detect (Figure 7-24).

## CHARGING SYSTEM REQUIREMENT TEST

It is possible to have a charging system that is working properly, yet not meet the requirements of the vehicle's electrical system. If an AC generator is installed on the vehicle without sufficient output to meet the demands of the vehicle, the customer may have complaints that are identical to those of a charging system that is not functioning at all. The actual AC generator output should be at least 10% to 20% greater than the load demand. The charging system requirement test is used to determine the total electrical demand of the vehicle's electrical system.

### To determine the vehicle's electrical requirement:

1. Connect the large red and black leads across the battery, observing polarity.
2. Select the CHARGING position.
3. Select INT 18 V.
4. Zero the ammeter.
5. Clamp the inductive pickup around all of the negative battery cables.
6. Turn the ignition switch to the RUN position. Do not start the engine.
7. Turn on all accessories to their highest positions.
8. Read the ammeter. The indicated amperage is the total load demand of the vehicle.



### SERVICE TIP:

In order to get an accurate reading using a DMM, it must be capable of an RMS reading.



### SERVICE TIP:

Most DMMs have a diode test function that can also be used to determine if a diode in the AC generator is open or shorted.



### SPECIAL TOOLS

Starting/charging system tester



## SPECIAL TOOLS

Fender covers  
Pry bar  
Belt tension gauge  
Battery terminal  
puller

## AC GENERATOR REMOVAL AND REPLACEMENT

AC generator removal varies according to the engine size, engine placement, and vehicle accessories (such as power steering and air conditioning). The following is the typical procedure for removal and replacement of the AC generator:

1. Place fender covers over the fenders.
2. Disconnect the battery ground cable.



**WARNING:** Never attempt to remove the AC generator or disconnect any wires to the generator without first disconnecting the battery negative cable. Always wear safety glasses when working around the battery.

3. Disconnect the wiring harness connections to the AC generator.
4. Loosen the drive belt tensioner.
5. Remove the drive belt.
6. Remove the upper bolt that attaches the AC generator to the mounting bracket.
7. Remove the generator lower bolt while supporting the generator.
8. Remove the generator from the vehicle.

Reverse the removal procedure to install the AC generator.

## Belt Tension Adjustment

There are various methods used by the manufacturers to adjust the belt tension. However, regardless of the procedure, it is important that the use of the right belt is confirmed and that it is installed over the pulleys properly. The belt must be of the proper length, width, depth, and type. There are two types of belts that are commonly used. The first is the “V” belt (Figure 7-25). This belt fits into a v-shaped groove in the pulleys. For proper operation, the belt must fit into the pulley so it makes full contact with the pulley (Figure 7-26).

Most manufacturers now use a serpentine belt (Figure 7-27). This belt has a series of ribs around the inside that matches grooves on the pulleys. Make sure the ribs are properly fitted to the grooves of the pulleys (Figure 7-28).

Some belt's tension is adjusted at the generator mounting bracket (Figure 7-29). To adjust the belt tension, leave the pivot and adjusting arm bolts loose. Look up the correct



FIGURE 7-25 “V” belt.

© Delmar/Cengage Learning

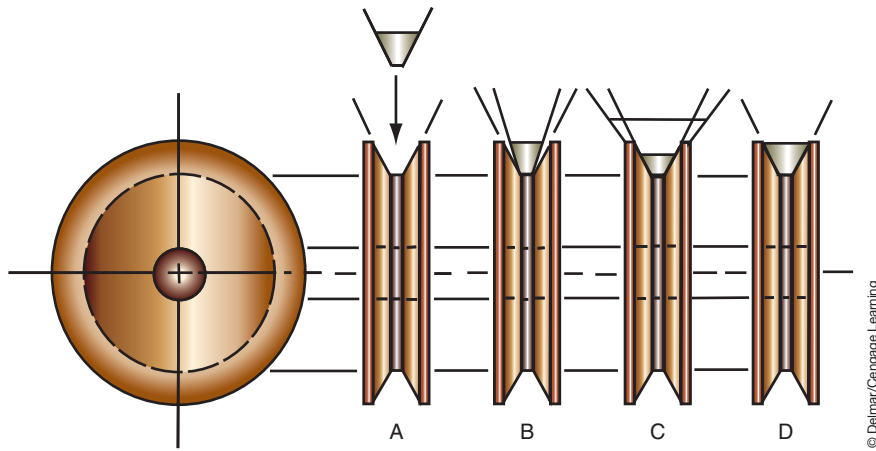


FIGURE 7-26 Proper installation and fit of the V belt is shown in D.



FIGURE 7-27 Serpentine belt.

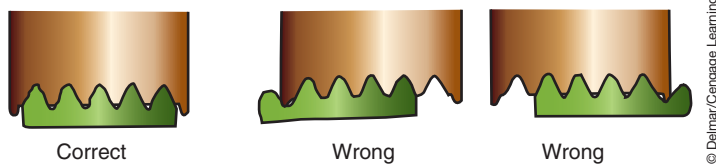


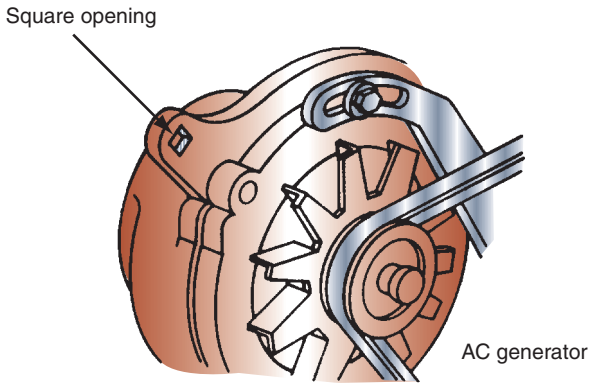
FIGURE 7-28 Proper installation of the serpentine belt.

belt tension specification for the vehicle you are working on. Install a belt tension gauge (refer to Figure 10-3) on the belt and use a square drive ratchet fitted into the square hole to rotate the generator until the proper belt tension is read on the gauge. If there is not a square hole or other method of moving the generator, then apply pressure with a pry bar to the front housing of the AC generator only. Once the correct tension reading is obtained, tighten the bolts to specified torque value. Manufacturers may provide different specifications for new and used belts. A belt is considered used if it has more than 15 minutes of run time.

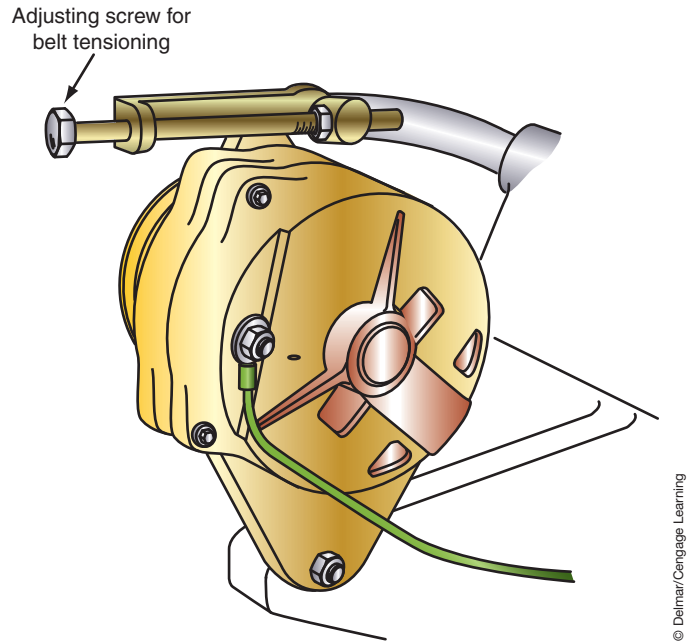
Another method of adjusting the belt tension at the generator mounting brackets incorporates the use of an adjusting screw (Figure 7-30). This does away with the need to pry against the generator housing and provides an easier method of making the adjustment. The



**CAUTION:**  
Do not pry on the rear housing of the generator. It may crack the housing.



**FIGURE 7-29** A typical method of adjusting belt tension at the brackets of the generator.



**FIGURE 7-30** Some generators are fitted with an adjustment screw to adjust the belt tension.



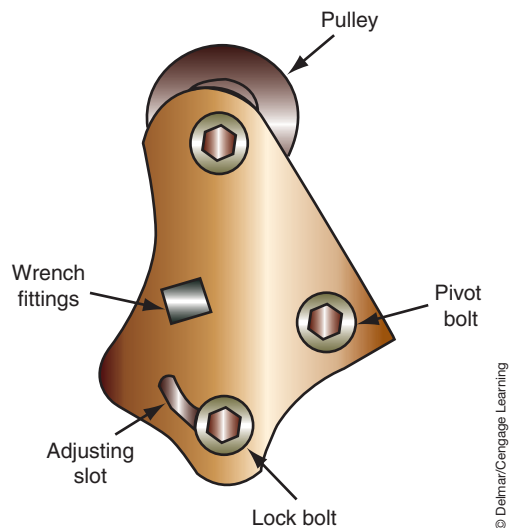
**CAUTION:**

Do not remove or loosen the fastener that holds the tensioner to the engine block prior to removing the belt. Use a square drive ratchet to rotate the pulley out of the belt and remove the belt. Loosening or removing the tensioner mounting bolts before the belt is removed may damage the engine block or the tensioner.

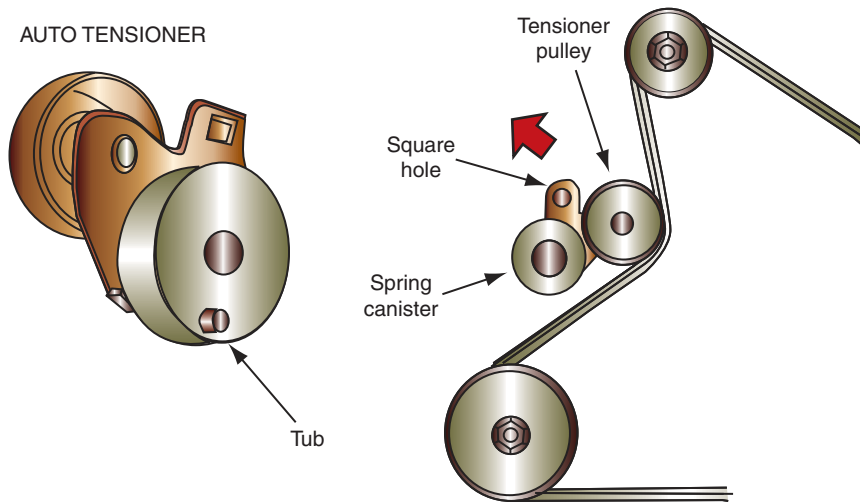
procedure is the same as just described, but turn the adjusting screw until the proper belt tension is obtained, then tighten the pivot bolts to the correct torque.

On many newer engines, the generator is rigidly mounted to the bracket or engine block and the belt tension is done at an idler pulley. Many will have a pivot bolt and adjusting slot (Figure 7-31). Some provide a fitting hole for a ratchet handle to fit into to provide an easy method of applying tension to the belt.

Most engines now use an automatic belt tensioner (Figure 7-32). This system has a tensioner that uses a spring or hydraulic pressure to automatically maintain the proper belt tension. The auto tensioner maintains this belt tension throughout the life of the belt. Using an automatic belt tensioner system increases belt life and prevents bearing damage to driven components. A tab or boss on the back of the canister fits into a hole in the bracket or engine block. This provides an anchor point. The spring works to maintain a constant pressure that rotates the pulley assembly into the belt. The square hole is used to rotate the tensioner away from the belt during belt removal and installation.



**FIGURE 7-31** Adjustment may be done at the idler pulley.



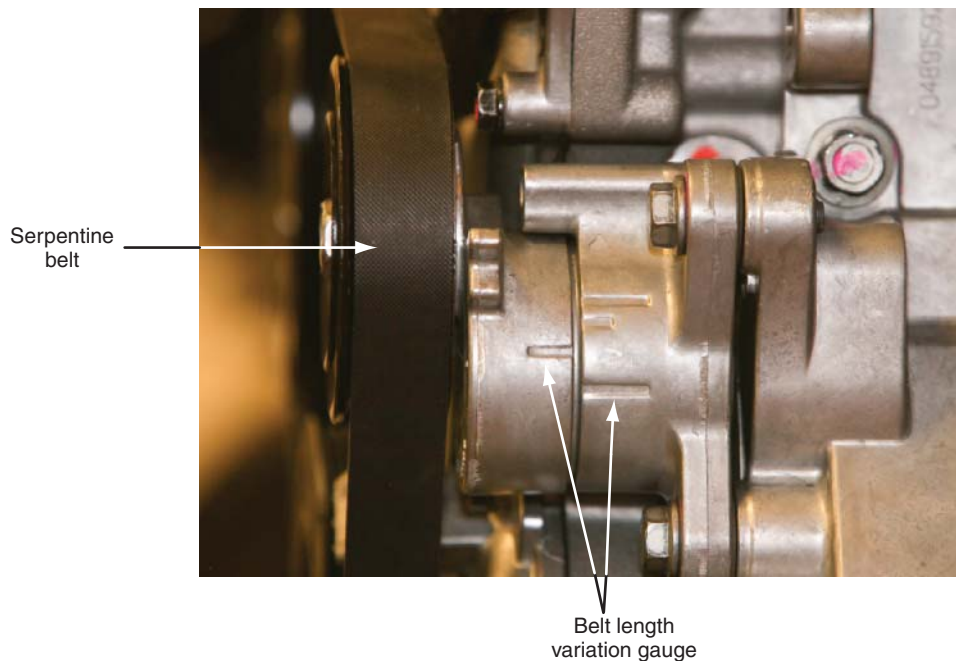
© Delmar/Cengage Learning

**FIGURE 7-32** Most vehicles use an automatic belt tensioner.

Some automatic tensioners have a built in wear gauge (Figure 7-33). As the belt wears and stretches, the tensioner will continue to attempt to maintain the proper tension. To do this the spring or hydraulics will force the tensioner to move into the belt. When the belt is worn beyond acceptable limits, the marks will align indicating by a quick inspection that the belt requires replacement.

Many manufacturers now give belt tension specifications in frequency. A frequency measuring tool equipped with a special microphone probe is used to measure the frequency of the belt to determine proper tension. The end of the microphone probe is placed about 1 in. (25 mm) from the belt in the center of the span between pulleys. Using your finger, pluck the belt a minimum of three times. The tool will display the frequency in hertz (Hz). Adjust the belt until the proper frequency is obtained.

Photo Sequence 13 illustrates a typical procedure for inspecting and replacing a serpentine belt.



© Delmar/Cengage Learning

**FIGURE 7-33** Some automatic tension adjusters have a wear indicator.



# PHOTO SEQUENCE 13

## TYPICAL PROCEDURE FOR INSPECTING AND REPLACING A SERPENTINE BELT

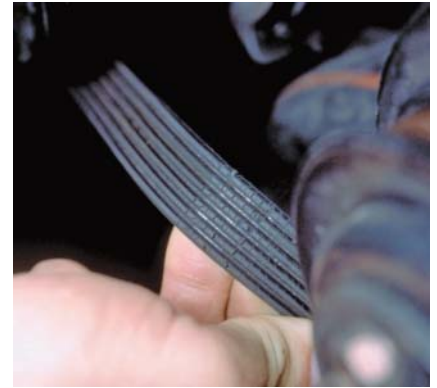
All photos in this sequence are © Delmar/Cengage Learning.



**P13-1** Inspect both sides of the belt.



**P13-2** The belt must be replaced if it is glazed.



**P13-3** Check for cracking and tearing of the belt ribs.



**P13-4** Identify the location of the belt tension adjustment.



**P13-5** If needed, loosen the mounting bracket bolt for idler or generator.



**P13-6** Pry the idler pulley or generator to release the tension on the belt and remove the belt.



**P13-7** Confirm that the new belt is the same size as the old one.

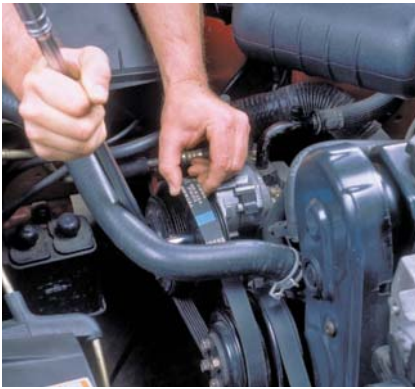


**P13-8** Refer to the belt routing diagram that is located on a placard in the engine compartment.



**P13-9** Install the new belt over each of the pulleys following the recommended sequence.





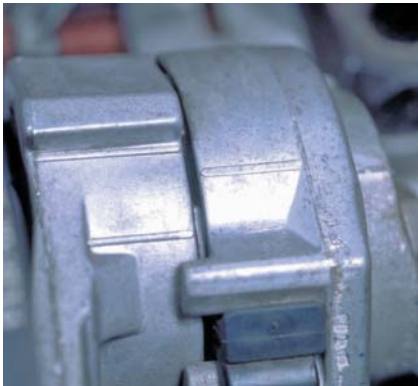
**P13-10** Pry out the idler or generator pulley to put tension against the belt.



**P13-11** Confirm that the belt is properly located into each pulley.



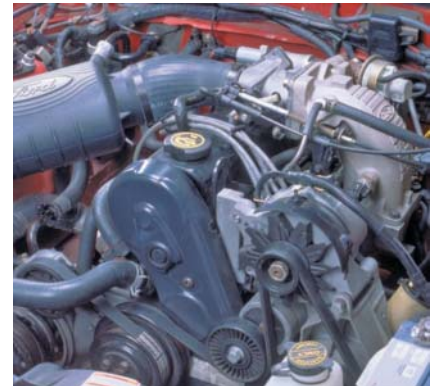
**P13-12** Measure the deflection of the belt or use a gauge as recommended by the manufacturer.



**P13-13** Pry the idler pulley or generator to tighten the belt tension until the proper tension is obtained.



**P13-14** Tighten the fasteners to the proper torque specifications.



**P13-15** Start the engine and confirm proper belt operation and tracking.

## AC GENERATOR DISASSEMBLY

If the AC generator fails the previous tests, the technician must decide whether to rebuild or replace the AC generator. This decision is based on several factors:

1. What is best for the customer.
2. Shop policies.
3. Cost.
4. Time.
5. Type of AC generator.

Once the decision is made to disassemble the AC generator, the technician should study the manufacturer's service information and become familiar with the procedure for the particular AC generator being rebuilt. Photo Sequence 14 shows the procedure for disassembling the Ford IAR AC generator. A disassembled view of this AC generator is shown (Figure 7-34).

Once the AC generator is disassembled, the components must be cleaned and inspected. Using a clean cloth, wipe the stator, rotor, and front bearing. Do not use solvent cleaners on these components. Inspect the front and rear bearings by rotating them on the rotor shaft. Check for noises, looseness, or roughness. Replace the defective bearing if any of these conditions are present.

Check the rotor shaft rear bearing surface. If the surface is not smooth, the rotor will have to be replaced. Visual inspection of the rotor includes checking the slip rings for smoothness



### SPECIAL TOOLS

- Ohmmeter
- 100-watt soldering iron
- Resin core solder
- Arbor press
- Soft jaw vise
- Scribe
- High-temperature bearing grease
- 400-grain emery cloth
- Pulley puller
- Clean rags
- Heat sink grease

# PHOTO SEQUENCE 14

## TYPICAL PROCEDURE FOR IAR GENERATOR DISASSEMBLY

All photos in this sequence are © Delmar/Cengage Learning.



**P14-1** Always have a clean and organized work area. Tools required to disassemble the Ford IAR AC generator: rags, T20 TORX wrench, plastic hammer, arbor press, 100 watt soldering iron, soft jaw vise, safety glasses, and assorted nut drivers.



**P14-2** Using a T20 TORX, remove the four attaching screws that hold the regulator to the AC generator rear housing.



**P14-3** Remove the regulator and brush assembly as one unit.



**P14-4** Using a T20 TORX, remove the two screws that attach the regulator to the brush holder. Separate the regulator from the brush holder. Remove the A terminal insulator from the regulator.



**P14-5** Scribe or mark the two housing ends and the stator core for reference during assembly.



**P14-6** Remove the three through bolts that attach the two housings.



**P14-7** Separate the front housing from the rear housing. The rotor will come out with the front housing, while the stator will stay with the rear housing. **NOTE:** It may be necessary to tap the front housing with a plastic or dead weight hammer to get the halves to separate.



**P14-8** Separate the three stator lead terminals from the rectifier bridge.



**P14-9** Remove the stator coil from the housing.



## PHOTO SEQUENCE 14 (CONTINUED)



**P14-10** Using a T20 TORX, remove the four attaching bolts that hold the rectifier bridge.



**P14-11** Remove the rectifier bridge from the housing.



**P14-12** Use a socket to tap out the bearing from the housing.



**P14-13** Clamp the rotor in a soft jaw vise.



**P14-14** Remove the pulley attaching nut, flatwasher, drive pulley, fan, and fan spacer from the rotor shaft.



**P14-15** Separate the front housing from the rotor. If the stop ring is damaged remove it from the rotor, if not leave it on the rotor shaft.



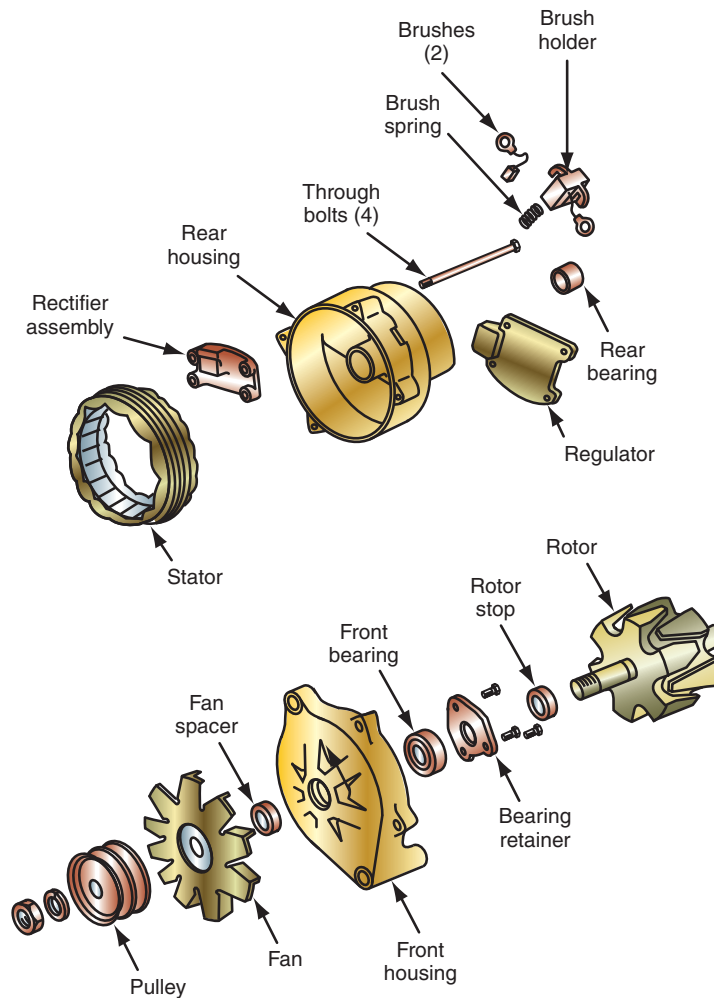
**P14-16** Remove the three screws that hold the bearing retainer to the front housing.



**P14-17** Remove the bearing retainer.



**P14-18** Remove the front bearing from the housing. **NOTE:** It may be necessary to use an arbor press to remove the bearing if it does not slide out.



**FIGURE 7-34** Disassembled view of Ford's IAR generator.

© Delmar/Cengage Learning

**Classroom Manual**

Chapter 7, page 171

and roundness. If the rings are discolored, dirty, scratched, nicked, or have burrs, they may be cleaned with fine-grit emery cloth. Caution must be observed to prevent creating flat spots while polishing the slip rings. The minimum diameter of the slip rings is 1.22 in. (31 mm).

Inspect the terminals and wire leads of the rotor and stator. Also, check both the rotor and stator for signs of burnt insulation of the windings. If there is damage to the insulation, replace the component.

Inspect the housing halves for cracks. Also check the fan and pulley for looseness on the rotor shaft and for cracks. Replace any part that does not pass inspection. Remove the heat transfer grease that is in the rectifier mounting area with a clean cloth.

The AC generator's brushes should be inspected and tested anytime the unit is disassembled. Brushes should be replaced whenever they are worn shorter than 1/4 in. (6.35 mm) in length. Also, the brush springs must be checked for sufficient strength to keep constant contact of brushes with slip rings. Brush continuity may be checked using an ohmmeter. There should be zero resistance through the brush path. Replace the brushes if there is any resistance indicated.

**AC GENERATOR COMPONENT TESTING**

Once the AC generator is disassembled and cleaned, the individual components can be tested. The chart (Figure 7-35) illustrates the test connections and results for the major components.

COMPONENT	TEST CONNECTION	NORMAL READING	IF READING WAS:	TROUBLE IS:
Rotor	Ohmmeter from slip ring to rotor shaft	Infinite resistance	Very low	Grounded
	Test lamp from slip ring to shaft	No light	Lamp lights	Grounded
	Test lamp across slip rings	Lamp lights	No light	Open
Stator	Ohmmeter from any stator lead to frame	Infinite resistance	Very low	Grounded
	Test lamp from lead to frame	No light	Lamp lights	Grounded
	Ohmmeter across any pair of leads	Less than $1/2 \Omega$	Any very high reading	Open
Diodes	Ohmmeter across diode, then reverse leads	Low reading one way; high reading other way	Both readings low Both readings high	Shorted Open
	12-V test lamp across diode, then reverse leads	Lamp lights one way, but not other way	No light either way Lamp lights both ways	Open Shorted

FIGURE 7-35 Guidelines for bench testing a generator.

© Delmar/Cengage Learning

## Testing the Rotor

The most important test of a rotor is a complete visual inspection. Carefully check the rotor windings for signs of discoloration or overheating. If these signs are present, the rotor is not good. Also carefully inspect the slip rings; they should be flat, smooth, and free of damage. If the rotor passes the visual inspection, proceed to test it with an ohmmeter.

An ohmmeter can be used to measure the resistance between the slip rings (Figure 7-36). Always check the manufacturer's service information for the correct specification for the unit you are working on. If specifications are not available, the following are some typical values:

GM	2.4 to 3.5 $\Omega$
Ford	3.0 to 5.5 $\Omega$
Chrysler	3.0 to 6.0 $\Omega$

If the resistance reading is below specifications, then the rotor is shorted. If the resistance is high, the rotor connections are badly corroded or open. The rotor must be replaced if any of these conditions are found.

Connecting the ohmmeter from each of the slip rings to the rotor shaft should show infinite resistance (Figure 7-37). If the reading was very low, the field coil is grounded and the rotor will have to be replaced.

## Testing the Stator

When testing a stator, a visual inspection is the most productive test. Look for discoloration or other damage to the windings. Often the assembly will look fine but will actually be damaged due to excessive heat. One quick way of checking for this is to take the blade of a knife and scrape the windings. If the coating or varnish flakes off, the windings have been overheated and the varnish is baked. Pay special attention to the connectors. Any signs of damage or breakage indicate the stator should not be reused. If the stator passes the visual inspection, it should be checked for opens and shorts to ground with an ohmmeter. To test for an open,

### Classroom Manual

Chapter 7, page 169



### SPECIAL TOOLS

Ohmmeter

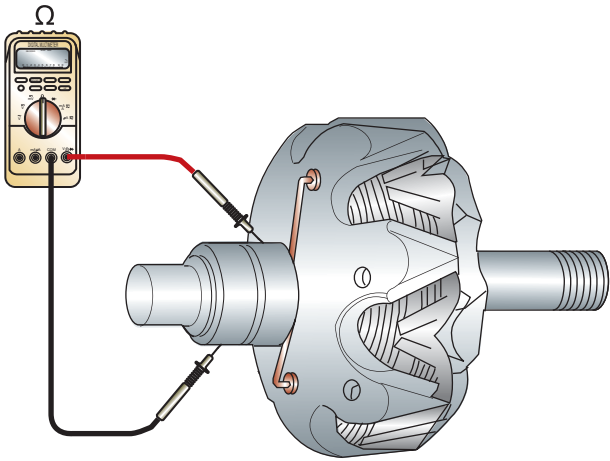
### Classroom Manual

Chapter 7, page 171



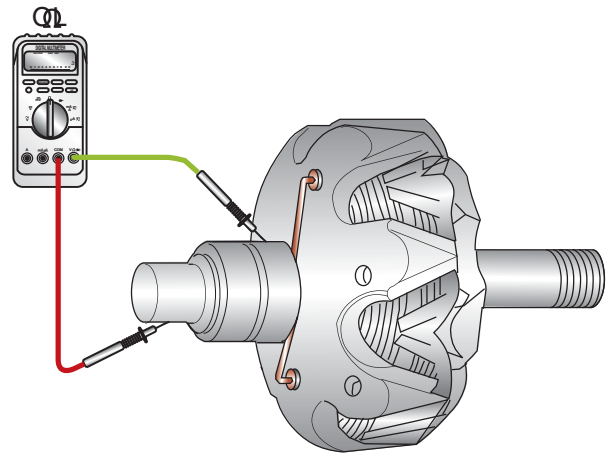
### SPECIAL TOOL

Ohmmeter



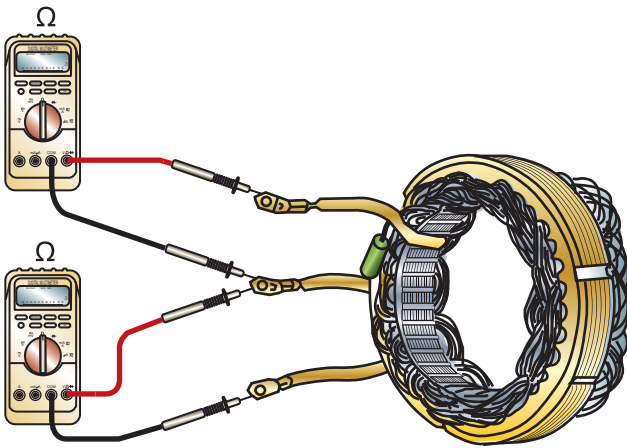
© Delmar/Cengage Learning

**FIGURE 7-36** Test connections for checking for opens in the rotor windings.



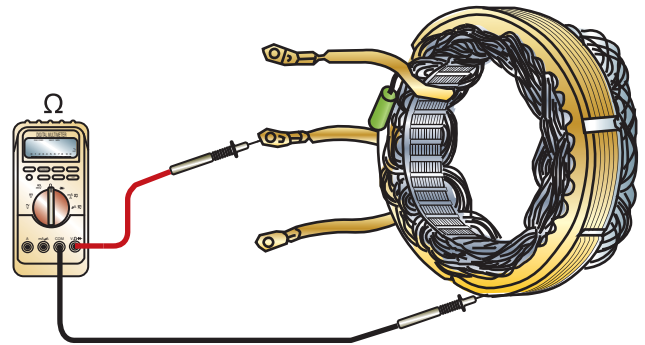
© Delmar/Cengage Learning

**FIGURE 7-37** Testing the rotor for shorts to ground.



© Delmar/Cengage Learning

**FIGURE 7-38** Testing the stator for opens.



© Delmar/Cengage Learning

**FIGURE 7-39** Testing the stator for shorts to ground.

Remove the stator leads from the diodes before testing the stator windings.

### Classroom Manual

Chapter 7, page 173



### SPECIAL TOOL

Analog ohmmeter  
DMM

connect the ohmmeter test leads to any pair of stator leads (Figure 7-38). Continue to test the stator until all combinations of pair connections are completed. On all of these connections, the resistance should be less than 0.5 volt. If the ohmmeter reads infinity between any two leads, the stator has an open and it must be replaced.

To test the stator for a short to ground, connect the ohmmeter to the stator leads and stator frame (Figure 7-39). The ohmmeter should read infinity on all three stator leads. If the reading is less than infinity, the stator is shorted to ground and it must be replaced.

## Testing the Diodes (Rectifier Bridge)

Because a diode should allow current to flow in only one direction, it must be tested for continuity in both directions. Using the analog ohmmeter or the diode test function of the DMM, connect the test leads to the diode lead and case (Figure 7-40). Read the ohmmeter scale. If the diode is good, it will show high resistance in one direction and low resistance in the opposite direction. If both readings are low, the diode is shorted. If there is high resistance in both directions, the diode is open. Test all six diodes and replace any that are defective.

## Testing the Diode Trio

If the AC generator is equipped with a diode trio, it must be tested for opens and shorts. The procedure is much the same as with the rectifier bridge test. Connect one of the DMM test leads to the signal connector. Connect the other test lead to one of the three



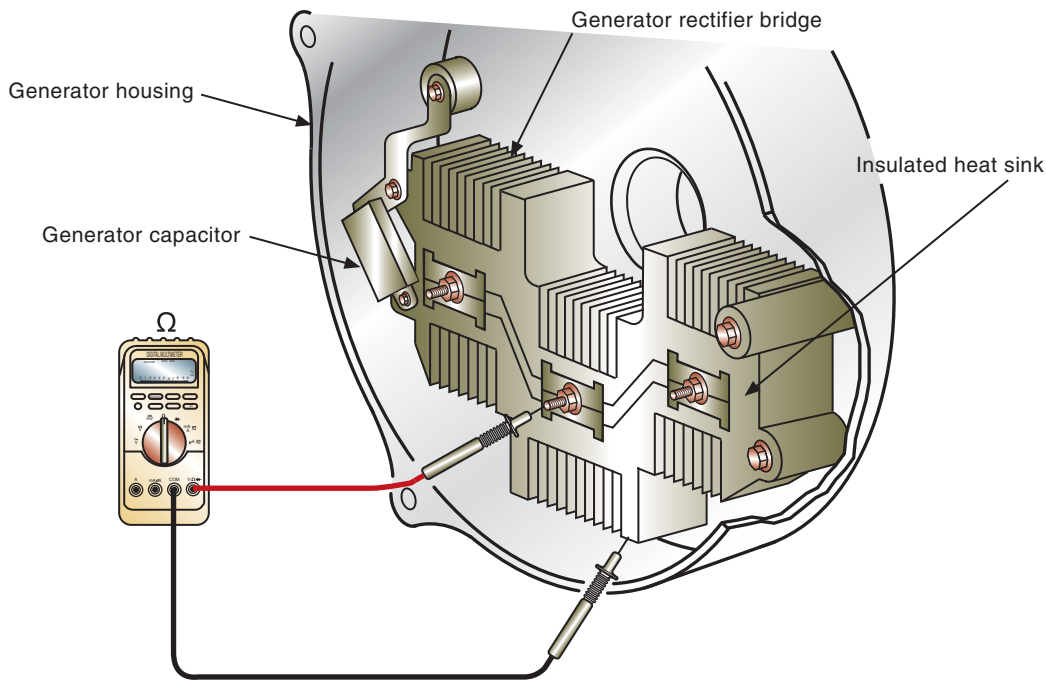


FIGURE 7-40 Testing the rectifier bridge.

© Delmar/Cengage Learning

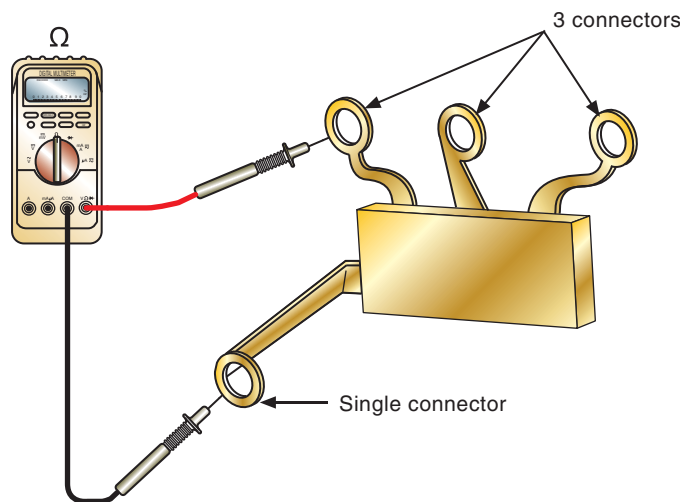


FIGURE 7-41 Diode trio test connections.

© Delmar/Cengage Learning

connectors (Figure 7-41). Test each of the three connectors in diode test mode. Record your readings.

Reverse the ohmmeter leads and record the readings obtained on each of the three connectors. The ohmmeter should read “OL” in one direction and above 600 mV in the other direction. These results should be obtained on all three connections. If not, replace the diode trio.

## AC GENERATOR REASSEMBLY

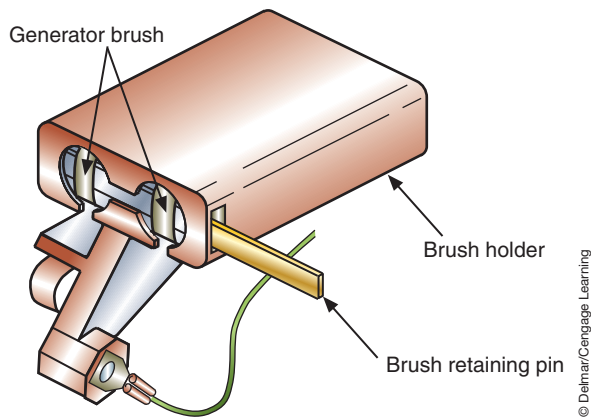
The reassembly procedure is basically the reverse order of the disassembly. The following are suggestions to assist in the assembly process:

1. Always check the manufacturer’s specifications for the proper torque values of the attaching screws.
2. Use high-temperature grease on the bearings.



### SERVICE TIP:

A shorted stator is difficult to test for because the resistance is very low for a normal stator. If all other components test okay, but output was low, a shorted stator is the probable cause.



**FIGURE 7-42** When assembling a generator, use a pin to hold the brushes back so the rotor can be inserted into the brush holder.

3. Check for free rotor rotation after installing and torquing the pulley to the rotor shaft.
4. Apply heat sink grease across the rectifier bridge base plate.
5. Protect the diodes from excess heat while soldering the connections. Use a pair of needle nose pliers as a heat sink.

When assembling a generator, always follow the recommendations of the manufacturer. It is critical that all screws and bolts be installed with the insulating washers that were present before disassembly. These insulators maintain proper circuit polarity. If a washer is left out, a short circuit will exist.

When installing the rotor into the brushes, most generators are equipped with a hole that allows a pin or paper clip to be inserted into the brush holder to keep the brushes back and allow the rotor to fit into them (Figure 7-42). After the rotor is in place, the pin can be removed and the brushes will snap into place on the slip rings. Before installing the pin to hold the brushes, make sure the brush springs are properly positioned behind the brushes.

### Classroom Manual

Chapter 7, page 203

## HEV INVERTER/CONVERTER



**WARNING:** Follow all safety precautions associated with working on or around the high voltage system. Failure to follow all procedures may result in death.

The HEV uses an inverter to invert the DC voltage from the HV battery into three-phase AC voltage for use by the motors. It is also used to rectify the AC voltage from the motors when they are functioning as generators to charge the DC HV battery. The converter is a bidirectional DC/DC converter that changes the HV DC to LV DC to recharge the 12-volt battery.

Failures of these components to charge the batteries usually results in the setting of a DTC. This means that a majority of the diagnostics will be based on the trouble code retrieved and following the steps outlined by the manufacturer. Keep in mind that the condition of the HV cables, HV connections, LV connections, and circuits must be confirmed as in any system. In most cases, if there is no fault found in the cable or connections, the inverter or converter is replaced.



### SPECIAL TOOL

Isolation Meter  
DMM  
Isolation gloves

# CASE STUDY

A customer complains that his vehicle's engine "dies" and requires a jump-start. The engine will run for a few minutes, then die again. If the headlights are turned on while the engine is running, the engine dies immediately.

The technician boost starts the engine to confirm the customer's complaint. The engine dies just as reported. The technician slow charges the battery to full capacity. Next, a full battery test series is performed. The battery passes all tests.

The technician then performs a visual inspection of the charging system. During this check, a worn and glazed AC generator drive belt is discovered. The technician does not know for certain yet if the belt is the only problem. However, the charging system tests will not be accurate if the belt is worn. The customer

is informed of what the technician has found thus far, and that other tests will still need to be performed to confirm any other problems. The technician gives the customer an estimate for the belt and receives permission to replace it.

After the new belt is installed, the technician performs the voltage output test and the current output test. The requirement test is also performed to confirm that the correct size AC generator is installed. The technician also checks the diode pattern. The charging system passes all tests.

The customer is notified that the car is ready to be picked up. When the customer arrives, the technician tactfully reminds the customer that all belts should be checked every 6 months and replaced per the manufacturer's maintenance schedule.

## TERMS TO KNOW

- Current output test
- Diode/stator test
- Field current draw test
- Full field test
- Full fielding
- Multiplying coil
- Voltage drop test
- Voltage output test

## ASE-STYLE REVIEW QUESTIONS

- Charging system testing is being discussed.  
*Technician A* says before attempting to test the charging system, the battery must be checked.  
*Technician B* says the state of charge of the battery is not a concern to charging system testing.  
Who is correct?  
A. A only                      C. Both A and B  
B. B only                      D. Neither A nor B
- AC generator noise complaints are being discussed.  
*Technician A* says a loose belt will make a grumbling noise.  
*Technician B* says a whining noise can be caused by a shorted diode.  
Who is correct?  
A. A only                      C. Both A and B  
B. B only                      D. Neither A nor B
- Technician A* says the no-load/load voltage output test is used to make a quick determination concerning whether or not the charging system is working properly.  
*Technician B* says when testing a charging system, the first step is to perform a visual inspection and preliminary checks of the charging system.  
Who is correct?  
A. A only                      C. Both A and B  
B. B only                      D. Neither A nor B
- Test results of the voltage output test are being discussed.  
*Technician A* says if the charging voltage is too high, there may be a loose or glazed drive belt.  
*Technician B* says if the charging voltage is too low, the fault might be a grounded field wire from the regulator (full fielding).  
Who is correct?  
A. A only                      C. Both A and B  
B. B only                      D. Neither A nor B

5. Voltage drop testing is being discussed.  
*Technician A* says the total system drops should be less than 0.7 volt.  
*Technician B* says the ground side voltage drop should be less than 0.2 volt.  
 Who is correct?  
 A. A only                      C. Both A and B  
 B. B only                      D. Neither A nor B
6. *Technician A* says the field current draw test determines if there is current available to the field windings.  
*Technician B* says a slipping belt can cause a low reading when performing the field current draw test.  
 Who is correct?  
 A. A only                      C. Both A and B  
 B. B only                      D. Neither A nor B
7. Full field test procedures are being discussed.  
*Technician A* says to full field a GM A circuit AC generator, insert a screwdriver into the D-shaped test hole and ground the tab.  
*Technician B* says check the rotor and field circuit resistance before full fielding the IAR AC generator.  
 Who is correct?  
 A. A only                      C. Both A and B  
 B. B only                      D. Neither A nor B
8. *Technician A* says full fielding means the field windings are constantly energized with full battery voltage.  
*Technician B* says the full fielding test should be performed only if the charging system passes the output test.  
 Who is correct?  
 A. A only                      C. Both A and B  
 B. B only                      D. Neither A nor B
9. *Technician A* says if full fielding with the regulator bypassed produces lower-than-specified output, the regulator is the cause of the problem.  
*Technician B* says the full field test will isolate whether the detected problem lies in the AC generator or the regulator.  
 Who is correct?  
 A. A only                      C. Both A and B  
 B. B only                      D. Neither A nor B
10. *Technician A* says all AC generators have a means of full fielding and bypassing the regulator.  
*Technician B* says many import and domestic AC generators must be disassembled to determine the cause of the charging system failure.  
 Who is correct?  
 A. A only                      C. Both A and B  
 B. B only                      D. Neither A nor B

## ASE CHALLENGE QUESTIONS

1. A vehicle's battery discharges in a very short period of time due to a shorted cell. Before replacing the battery, a charging system test is performed. The engine is started and all accessories are turned off.  
*Technician A* says that the charging system's amperage output will be lower than normal.  
*Technician B* says that the alternator's field current will be high when the engine is running.  
 Who is correct?  
 A. A only                      C. Both A and B  
 B. B only                      D. Neither A nor B
2. The charging system voltage of a vehicle equipped with an external voltage regulator is 15.5 volts at 1,500 rpm.  
*Technician A* says that the voltage regulator sensing circuit may have excessive resistance.  
*Technician B* says that the alternator's field circuit may have excessive resistance.  
 Who is correct?  
 A. A only                      C. Both A and B  
 B. B only                      D. Neither A nor B

3. Charging system voltage is being measured at two places at the same time.

Connecting the voltmeter's leads across the battery terminals results in a 12.8-volt reading, while connecting the voltmeter to the alternator output terminal and the alternator case results in a 14.2-volt reading.

*Technician A* says that there may be excessive resistance on the ground side of the charging system.

*Technician B* says that there may be excessive resistance on the positive side of the charging system.

Who is correct?

- A. A only                      C. Both A and B  
B. B only                      D. Neither A nor B

4. A customer says that his battery completely discharges every few days even though he drives his car daily 50 miles. A test of his charging system is performed and the following measurements are recorded with all accessories turned "on."

At 1,300 rpm the charging system voltage and amperage is 12.4 volts and 60 amps. A replacement alternator produces the same measurements.

*Technician A* says that there may be excessive electrical demand on the alternator.

*Technician B* says that the charging system may have excessive voltage drop.

Who is correct?

- A. A only                      C. Both A and B  
B. B only                      D. Neither A nor B

5. Which of the following could result in battery overheating and eventual premature failure?

- A. Open field circuit.  
B. Shorted stator windings.  
C. Open diode.  
D. High-resistance voltage regulator sensing circuit.

*This page intentionally left blank*



Name \_\_\_\_\_ Date \_\_\_\_\_

**INSPECTING DRIVE BELTS**

Upon completion of this job sheet, you should be able to visually inspect drive belts and check their tightness.

**ASE Correlation**

This job sheet is related to the ASE Electrical/Electronic System Certification Exam’s content area: *Charging System Diagnosis and Repair*; task: Inspect, adjust, and replace alternator drive belts, pulleys, and fans.

**Tools and Materials**

Two vehicles, one with a serpentine belt and the other with V belts  
 Service informations for the vehicles assigned  
 Belt tension gauge

**Describe the vehicles being worked on:**

Year \_\_\_\_\_ Make \_\_\_\_\_ Model \_\_\_\_\_

VIN \_\_\_\_\_ Engine type and size \_\_\_\_\_

Year \_\_\_\_\_ Make \_\_\_\_\_ Model \_\_\_\_\_

VIN \_\_\_\_\_ Engine type and size \_\_\_\_\_

**Procedure**

\_\_\_\_\_  
 Task Completed

1. On the vehicle with a serpentine belt, carefully inspect the belt and describe the general condition of the belt.

\_\_\_\_\_  
 \_\_\_\_\_  
 \_\_\_\_\_

2. With the proper belt tension gauge, check the tension of the belt. Belt tension should be \_\_\_\_\_. You found \_\_\_\_\_.

3. Based on the above, what are your recommendations?

\_\_\_\_\_  
 \_\_\_\_\_  
 \_\_\_\_\_

4. Describe the procedure for adjusting the tension of the belt.

\_\_\_\_\_  
 \_\_\_\_\_  
 \_\_\_\_\_

---

Task Completed

5. On the vehicle with V belts, you will find more than one drive belt. List the different belts by their purpose.

---

---

---

6. Carefully inspect the belts and describe the general condition of each one.

---

---

---

7. Check the tension of the AC generator drive belt. Belt tensions should be

\_\_\_\_\_. You found \_\_\_\_\_.

8. Based on the above, what are your recommendations?

---

---

9. Describe the procedure for adjusting the tension of the belt.

---

---

---

Instructor's Response \_\_\_\_\_

---

---

Name \_\_\_\_\_ Date \_\_\_\_\_

## TESTING CHARGING SYSTEM OUTPUT

Upon completion of this job sheet, you should be able to measure the output of the charging system.

### ASE Correlation

This job sheet is related to the ASE Electrical/Electronic System Certification Exam's content area: *Charging System Diagnosis and Repair*; task: Perform charging system output test; determine needed repairs.

### Tools and Materials

- A vehicle
- Service information for the vehicle assigned
- Starting/charging system tester (VAT-60 or similar)

### Describe the vehicle being worked on:

Year \_\_\_\_\_ Make \_\_\_\_\_ Model \_\_\_\_\_  
 VIN \_\_\_\_\_ Engine type and size \_\_\_\_\_

### Procedure

Task Completed

1. Identify the type and model of AC generator. What type is it?

\_\_\_\_\_

What are the output specifications for this AC generator?

\_\_\_\_\_ amps and \_\_\_\_\_ volts at \_\_\_\_\_ rpm

2. Connect the starting/charging system tester to the vehicle.
3. Start the engine and run it at the specified engine speed.
4. Observe the output to the battery. The meter readings are: \_\_\_\_\_ amps and \_\_\_\_\_ volts.

5. Compare readings to specifications and give recommendations.

\_\_\_\_\_  
 \_\_\_\_\_  
 \_\_\_\_\_  
 \_\_\_\_\_

---

Task Completed

6. If readings are outside of the specifications, refer to the service information to find the proper way to full field the AC generator. Describe the method.

---

---

---

---

7. Full field the generator and observe the output to the battery. The meter readings are: \_\_\_\_\_ amps and \_\_\_\_\_ volts.

8. Compare readings to specifications and give recommendations.

---

---

---

---

Instructor's Response \_\_\_\_\_

---

---

Name \_\_\_\_\_ Date \_\_\_\_\_

## TESTING THE CHARGING SYSTEM CIRCUIT

Upon completion of this job sheet, you should be able to visually inspect and test the insulated and ground side of the charging system circuit.

### ASE Correlation

This job sheet is related to the ASE Electrical/Electronic System Certification Exam’s content area: *Charging System Diagnosis and Repair*; task: Diagnose charging system problems that can cause undercharge, a no-charge, or an overcharge condition.

### Tools and Materials

- A vehicle
- Wiring diagram for the vehicle assigned
- A DMM

### Describe the vehicle being worked on:

Year \_\_\_\_\_ Make \_\_\_\_\_ Model \_\_\_\_\_  
 VIN \_\_\_\_\_ Engine type and size \_\_\_\_\_

### Procedure

Task Completed

1. Describe the general appearance of the AC generator and the wires that are attached to it.

\_\_\_\_\_  
 \_\_\_\_\_  
 \_\_\_\_\_

2. Measure the open circuit voltage of the battery. Your measurement was \_\_\_\_\_ volts.

3. From the wiring diagram, identify the output, input, and ground wires for the AC generator. Describe these wires, by color and location, below.

\_\_\_\_\_  
 \_\_\_\_\_  
 \_\_\_\_\_  
 \_\_\_\_\_

4. Start the engine and allow it to run. Then turn on the headlights in the high-beam mode. □

5. Connect the DMM across the charging system’s output wire. Measure the voltage drop and record your readings.

\_\_\_\_\_  
 \_\_\_\_\_

Task Completed

6. Connect the DMM across the charging system's input wire. Measure the voltage drop and record your readings.

---

7. Connect the DMM across the charging system's ground wire. Measure the voltage drop and record your readings.

---

8. Based on the test, what is indicated by the results?

---

---

---

Instructor's Response

---

---

---

<b>DIAGNOSTIC CHART 7-1</b>	
<b>PROBLEM AREA:</b>	Charging system operation
<b>SYMPTOMS:</b>	<ol style="list-style-type: none"><li>1. Battery is too low to start engine.</li><li>2. Headlight illumination dim.</li><li>3. Electrical accessories do not operate properly.</li><li>4. Charging indicator warning light illuminated.</li></ol>
<b>POSSIBLE CAUSES:</b>	<ol style="list-style-type: none"><li>1. Slipping or worn drive belt.</li><li>2. Poor battery cable connections.</li><li>3. Faulty voltage regulator.</li><li>4. Shorted stator.</li><li>5. Open stator.</li><li>6. Open diode.</li><li>7. Shorted diode.</li><li>8. Slipping or worn drive belt.</li><li>9. Worn brushes.</li><li>10. Open field coil circuit.</li><li>11. Shorted field coil.</li><li>12. Worn or slipping drive belt.</li><li>13. Worn brushes.</li><li>14. Faulty rectifier bridge.</li><li>15. Faulty diode trio.</li><li>16. Excessive resistance in system circuit.</li><li>17. Open in the circuit.</li><li>18. Improper ground connection.</li><li>19. Loose or corroded connection.</li></ol>



<b>DIAGNOSTIC CHART 7-2</b>	
PROBLEM AREA:	Charging system operation (excessive charging)
SYMPTOMS:	Battery electrolyte level constantly low. Bulbs burn out. Brighter than normal bulb illumination. Electrical system component failures.
POSSIBLE CAUSES:	1. Faulty voltage regulator. 2. Grounded field coil circuit. 3. Excessive resistance in sensing circuit. 4. Faulty generator.

<b>DIAGNOSTIC CHART 7-3</b>	
PROBLEM AREA:	Voltage regulation
SYMPTOMS:	1. Charging system overcharging the battery. 2. Charging system output below specifications.
POSSIBLE CAUSES:	1. Defective voltage regulator. 2. Open or short in sense circuit.

<b>DIAGNOSTIC CHART 7-4</b>	
PROBLEM AREA:	Diodes
SYMPTOMS:	1. Excessive noises. 2. Low or no charging system output. 3. AC generator fails output test.
POSSIBLE CAUSES:	1. Open diodes. 2. Shorted diodes.

<b>DIAGNOSTIC CHART 7-5</b>	
PROBLEM AREA:	AC generator pulleys
SYMPTOMS:	1. Belts wear prematurely. 2. Noises.
POSSIBLE CAUSES:	1. Pulley bent.

<b>DIAGNOSTIC CHART 7-6</b>	
PROBLEM AREA:	AC generator
SYMPTOMS:	Noises.
POSSIBLE CAUSES:	1. Bent fan blades. 2. Worn or dry bearings.

<b>DIAGNOSTIC CHART 7-7</b>	
PROBLEM AREA:	HEV 12-volt battery low SOC.
SYMPTOMS:	LV battery fails to charge. No HEV operation. MIL or HEV warning lamps.
POSSIBLE CAUSES:	1. 12-volt battery failure. 2. Low SOC of 12-volt battery. 3. High resistance in 12-volt battery cables or connections. 4. Improper inverter/converter module ground connection. 5. Poor or improper inverter/converter module LV connections. 6. Excessive LV system loads. 7. Faulty inverter/converter module.

<b>DIAGNOSTIC CHART 7-8</b>	
PROBLEM AREA:	HEV 12-volt battery high SOC
SYMPTOMS:	LV battery overcharged No HEV operation MIL or HEV warning lamps
POSSIBLE CAUSES:	1. 12-volt battery failure. 2. Improper jump-start procedures. 3. Overcharging with a battery charger 4. High resistance in 12-volt battery cables or connections. 5. Improper inverter/converter module ground connection. 5. Poor or improper inverter/converter module LV connections. 7. Faulty inverter/converter module.

# LIGHTING CIRCUITS REPAIR AND DIAGNOSIS



### BASIC TOOLS

Basic mechanic's tool set

Service information

## UPON COMPLETION AND REVIEW OF THIS CHAPTER, YOU SHOULD BE ABLE TO:

- Correctly replace sealed-beam and composite headlights.
- Correctly service the high-intensity discharge (HID) lamp and ballast.
- Correctly aim sealed-beam and composite headlights.
- Diagnose the cause of brighter-than-normal lights.
- Diagnose the cause of dimmer-than-normal lights.
- Diagnose lighting systems that do not operate.
- Determine causes for incorrect concealed headlight operation.
- Remove and replace dash-mounted and steering column-mounted headlight switches.
- Replace multifunction switches.
- Test and determine needed repairs of the dimmer switch and related circuits.
- Replace the dimmer switch.
- Diagnose incorrect taillight assembly operation.
- Diagnose the turn signal system for improper operation.
- Replace the turn signal switch.
- Diagnose the interior lights, including courtesy, instrument, and panel lights.

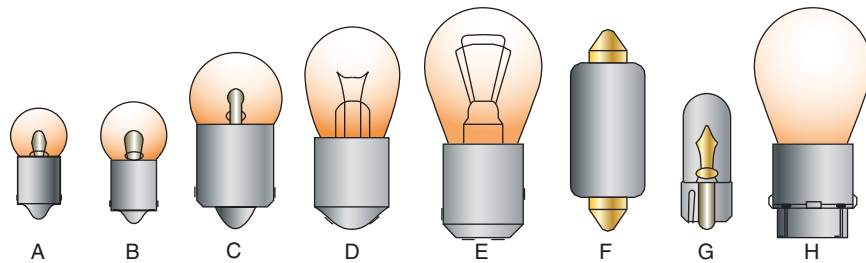
## INTRODUCTION

The lighting system of the vehicle is becoming very complex. There may be over 50 light bulbs and hundreds of feet of wiring in the lighting circuits. The circuits include circuit protectors, switches, lamps, and connectors. Any failure requires a systematic approach to diagnose, locate, and correct the fault in the minimum amount of time.

The importance of a proper operating lighting system cannot be overemphasized. The lighting system should be checked whenever the vehicle is brought into the shop for repairs. Often a customer may not be aware of a light failure. If a lighting circuit is not operating properly, there is a potential danger to the driver and other people. When today's technician performs repairs on the lighting systems, the repairs must assure vehicle safety and meet all applicable laws. Be sure to use the correct lamp type and size for the application (Figure 8-1).

Before performing any lighting system tests, check the battery for state of charge. Also, be sure all cable connections are clean and tight. Visually check the wires for damaged insulation, loose connections, and improper routing. A troubleshooting chart for the lighting system is located at the end of this chapter.

When troubleshooting the lighting system, if only one bulb is not operating it is usually faster to replace it with a known good unit first. Check the connector for signs of corrosion. When testing the circuit with a voltmeter, ohmmeter, or test light, check the most easily reached components first.



Common automotive bulbs:

- A,B Miniature bayonet for indicator and instrument lights
- C – Single contact bayonet for license and courtesy lights
- D – Double contact bayonet for trunk and underhood lights
- E – Double contact bayonet with staggered indexing lugs for stop, turn, and brake lights
- F – Cartridge type for dome lights
- G – Wedge base for instrument lights
- H – Blade double contact for stop, turn, and brake lights

© Delmar/Cengage Learning

**FIGURE 8-1** Correct selection of the lamp is important for proper operation of the system.

## Classroom Manual

Chapter 8, page 210



## SPECIAL TOOLS

Fender covers  
Safety glasses  
Torx drivers



## CAUTION:

Because of the construction and placement of the prisms in the lens, it is important that the headlight is installed in its proper position. The lens is usually marked "TOP" to indicate the proper installed position.

## Classroom Manual

Chapter 8, page 210

## HEADLIGHTS

There are four basic types of headlights used on automobiles today: standard sealed beam, halogen sealed beam, composite, and HID. The most common service performed on the headlights is lamp replacement and aiming. These procedures vary depending on the type of headlights used.

Because the lighting circuits are largely regulated by federal laws, the systems are similar between the various manufacturers. However, there are variations that exist in these circuits. Consult the service information for the vehicle you are working on.

## Headlight Replacement

One of the most common lighting system repairs is replacing the headlight. After a period of time, the filament may burn through or the lens may be broken. Before the headlight is replaced, however, a voltmeter or test light should be used to confirm that voltage is present. Next, check the ground for proper connections. If these test good, the headlight is probably faulty and needs to be replaced. If there is no voltage present at the connector, work back toward the switch and battery until the fault is located.

The procedure for replacing the headlight differs depending on the type of bulb used. Most conventional sealed-beam and halogen sealed-beam headlights are replaced in the same manner. Composites require different procedures. Always refer to the service information for the vehicle you are working on.

**Sealed-Beam.** Photo Sequence 15 illustrates a common procedure for replacing a sealed-beam headlight.

After confirming proper headlight operation, check headlight aiming as described in the next section.

**CUSTOMER CARE:** Because the filament of the halogen lamp is contained in its own bulb, cracking or breaking of the lens does not prevent headlight operation. The filament will continue to operate as long as the filament envelope has not been broken. However, a broken lens will result in poor light quality and should be replaced for the safety of the customer.

## REPLACING A SEALED-BEAM HEADLIGHT

All photos in this sequence are © Delmar/Cengage Learning.



**P15-1** Place fender covers around the work area.



**P15-2** Sealed-beam headlight replacement usually requires the removal of the bezel. Some vehicles may require that the turn signal light assembly be removed before the headlight is accessible.



**P15-3** Remove the retaining ring screws and the retaining trim. Do not turn the two headlight aiming adjustment screws.



**P15-4** Remove the headlight from the shell assembly.



**P15-5** Disconnect the wire connector from the back of the lamp.



**P15-6** Check the wire connector for corrosion or other foreign material. Clean as necessary.



**P15-7** Coat the connector terminals and the prongs of the new headlight with dielectric grease to prevent corrosion.



**P15-8** Install the wire connector onto the new headlight's connector prongs.



**P15-9** Place the headlight into the shell assembly. When positioning the headlight, be sure that the embossed number is at the top. Many headlights are marked "TOP."



## PHOTO SEQUENCE 15 (CONTINUED)



**P15-10** Install the retainer trim and fasteners.



**P15-11** Install the headlight bezel.



**P15-12** Check operation of the headlight.

### Classroom Manual

Chapter 8, page 212



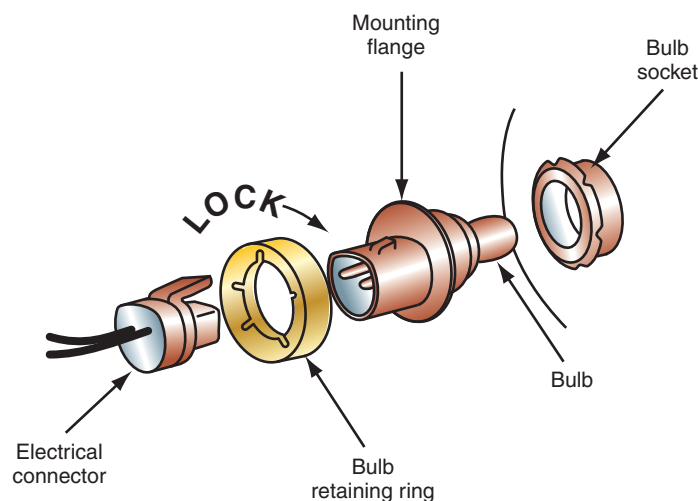
### CAUTION:

Do not get any of the dielectric grease onto the bulb. The bulb's life will be shortened.

Because the housings of a composite headlight system are vented, condensation may develop inside the lens assembly. This condensation is not harmful to the bulb and does not affect headlight operation.

**Composite.** To replace a composite headlight:

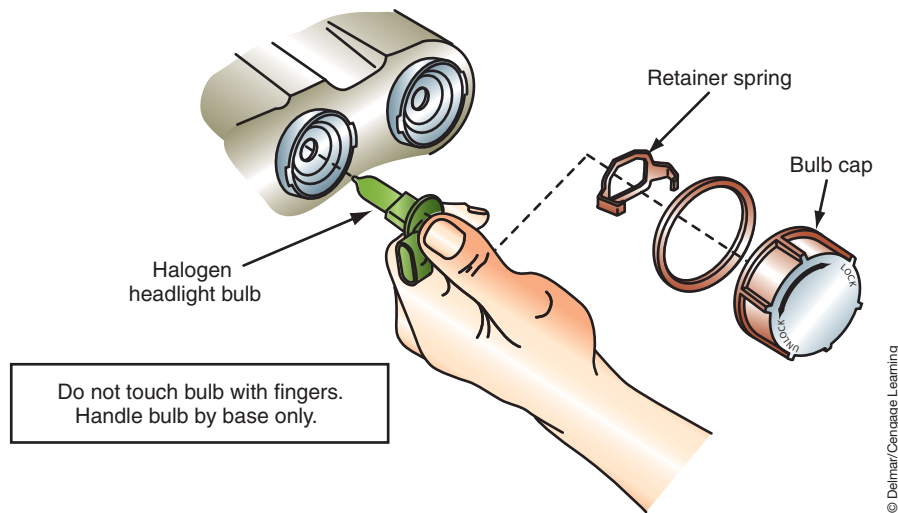
1. Place fender covers around the work area.
2. Remove the wire connector from the bulb.
3. Unlock the bulb retaining ring by rotating it 1/8 of a turn (Figure 8-2).
4. Slide off the retaining ring from the base.
5. Gently pull the bulb straight back out of the socket. To prevent breaking the bulb and locating tabs, do not rotate it while pulling.
6. Check the wire connector for corrosion or other foreign material. Clean as needed.
7. Coat the connector terminals and the prongs of the new headlight with dielectric grease to prevent corrosion.
8. Place the new bulb in the socket (Figure 8-3). The flat part of the base should face up. It may be necessary to turn the bulb slightly to align the locating tabs.
9. The mounting flange on the bulb base should contact the rear of the socket.
10. Install the retaining ring over the base and lock the ring into the socket.
11. Reconnect the wire connector to the bulb. It will snap and lock into position when properly installed.
12. Check headlight operation.
13. Check and adjust headlight aiming as needed.



**FIGURE 8-2** Composite headlight bulb replacement.

© Delmar/Cengage Learning





**FIGURE 8-3** The correct method of handling the composite bulb during replacement.



**CAUTION:**

Whenever replacing a halogen bulb, care must be taken not to touch the envelope with the fingers. Staining the bulb with normal skin oil can substantially shorten the life of the bulb. Handle the lamp only by its base. Also dispose of the old lamp properly. Wear safety glasses when handling halogen bulbs.



**WARNING:** Before testing the HID system, remove the headlight assembly from the vehicle. The HID system operates on high voltage and current. If the system is accidentally shorted, personal injury or death may occur.

**HID Lamp and Ballast Service.**

The high-intensity discharge (HID) lamps require battery voltage and ground to operate as any other lamp. The ballast has internal circuit protection to prevent damage resulting from an open or shorted circuit. In addition, the circuit protection will come into effect if an overcharge or undercharge condition exists. If any of these faults are detected, the headlights will not turn on for that key cycle, or until the fault is corrected. If the customer states that both headlights do not operate, recycle the ignition or the headlight switch to see if the condition reoccurs. If the lights are still not coming on, then check battery condition and the charging system. It is unlikely that both lamps failed at the same time, so check the switch input, HID relay, power feed, and ground.

A burned-out lamp will appear black or smoky. If a visual inspection does not indicate a faulty lamp, then check for battery voltage to the ballast. If battery voltage is above specifications, check the ground circuit for the ballast. If neither of these circuits has an open or short, then substitute a known good ballast. If the headlight on the opposite side of the vehicle is operating properly, substitute its ballast with the side that does not operate. If the headlight illuminates, replace the ballast. If the light still does not come on, replace the bulb/ignitor element.

Depending on design, it may be necessary to remove the headlight assembly prior to replacing the bulb and ignitor. Some vehicles provide access that allows the bulb and ignitor to be serviced without removing the headlight assembly. Regardless of how the bulb element is accessed, replacement procedures are very similar.

Prior to servicing the headlight element, disconnect and isolate the battery negative cable or remove the HID relay. This will prevent accidental operation of the headlights.



**WARNING:** The HID system produces a high voltage and current. Do not attempt to operate the headlights without all connections properly made.

**Classroom Manual**

Chapter 8, page 212



© Delmar/Cengage Learning

**FIGURE 8-4** The HID element is protected by a rubber boot on the back of the headlight assembly.



© Delmar/Cengage Learning

**FIGURE 8-5** The ignitor is connected to the ballast by a cable.

**⚠ WARNING:** Never attempt to open the ballast or ignitor assembly. The ignitor is a component of the bulb and cannot be separated.

To gain access to the bulb assembly, remove the rubber boot that protects the element (Figure 8-4). At the ignitor, disconnect the cable coming from the ballast (Figure 8-5). As seen in Figure 8-6, a wire clip will retain the element to the headlight assembly. Release the clip and remove the element by grabbing the ignitor and pulling the unit rearward. It may be necessary to rock the ignitor slightly as it is being pulled.

To install the new element, push the bulb element assembly into the headlight unit. Once properly seated, secure with the retainer clip. Connect the cable from the ballast to the ignitor's connector. Install the rubber protective cover. Make sure the cover is properly seated. If the cover is not seated, water may enter the element and damage the unit. If necessary, install the headlight assembly. Reconnect the battery or connect the relay and test for proper operation.

The ballast can be attached to the bottom of the headlight assembly, to the vehicle's frame, or to the inner fender well. A cable connects the ballast to the ignitor. In addition, another connector attaches the ballast to the vehicle's wiring system (Figure 8-6). It may be necessary



© Delmar/Cengage Learning

**FIGURE 8-6** HID ballast connectors.

to remove the headlight assembly to gain access to the ballast. Prior to removing the ballast, disconnect and isolate the battery negative cable or remove the HID relay.

Remove the screws that retain the ballast to the headlight assembly or frame. Next, disconnect the main electrical connector and the cable to the ignitor from the ballast. The cable may be secured by a wire lever that must be rotated down. Installation of the new ballast is reverse order of the removal procedure. Be sure to properly secure the wire retainer around the cable connector.

## Headlight Aiming

The headlights should be checked for proper aiming whenever the lamps are replaced. Proper aiming is important for good light projection onto the road and to prevent discomfort and dangerous conditions for oncoming drivers.

Correct headlight beam position is so critical that government regulations control limits for headlight aiming. For example, a headlight that is misaimed by one degree downward will reduce the vision distance by 156 feet (47.5 m). The following are maximum allowable limits that have been established by all states:

1. Low beam: In the horizontal plane, the left edge of the headlight high-intensity area should be within 4 inches (102 mm) to the right or left of the vertical centerline of the lamp. In the vertical plane, the top edges of the headlight high-intensity area should be within 4 inches (102 mm) above or below the horizontal centerline of the lamp (Figure 8-7).
2. High beam: In the horizontal plane, the center of the headlight high-intensity area should be within 4 inches (102 mm) to the right or left of the vertical centerline of the lamp. In the vertical plane, the center of the headlight high-intensity area should be within 4 inches (102 mm) above or below the horizontal centerline of the lamp (Figure 8-8).

Before the headlights are aimed, the vehicle must be checked for proper **curb height**. Curb height is the height of the vehicle when it has no passengers or loads and has normal fluid levels and tire pressure. This includes checking the springs; tire inflation; removing any

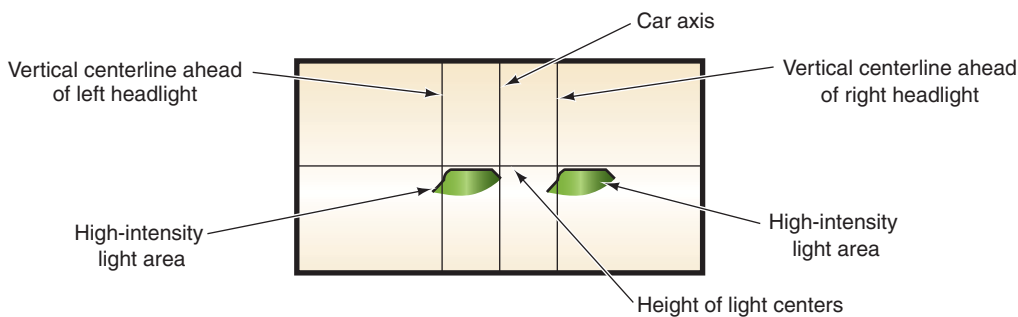


FIGURE 8-7 Low-beam headlight aiming adjustment pattern.

© Delmar/Cengage Learning

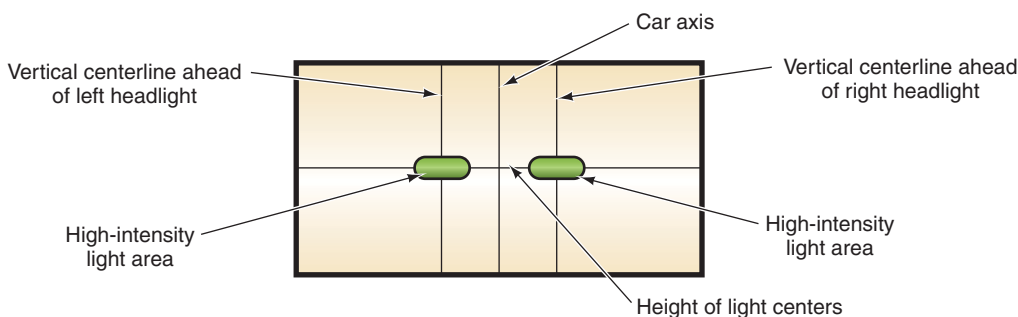


FIGURE 8-8 High-beam headlight aiming adjustment pattern.

© Delmar/Cengage Learning

### Classroom Manual

Chapter 8, page 210



### SPECIAL TOOLS

Headlight aiming unit  
Torx driver  
Fender covers  
Safety glasses

additional load in the vehicle; a half-filled fuel tank; and removing dirt, ice, snow, and so on, from the vehicle.

**Sealed-Beam.** Most shops use portable mechanical aiming units (Figure 8-9). These are secured to the headlight lens by suction cups (Figure 8-10). The aiming unit should have a variety of adapters to attach to the various styles of headlights. Before using the aiming equipment, be sure to follow the manufacturer's procedure for calibration. Park the vehicle on a level floor area and place fender covers around the work area. It may be necessary to remove the trim and bezel from around the headlight. Using the correct adapter, connect the calibrated aimer units to the headlights. Be sure the adapters fit the headlight aiming pads on the lens (Figure 8-11). Zero the horizontal adjustment dial. Confirm that the split-image target lines are visible in the view port (Figure 8-12). If the target lines are not seen, rotate the aimer unit. Turn the headlight horizontal adjusting screw until the split-image target lines are aligned. Repeat for the headlight on the other side.

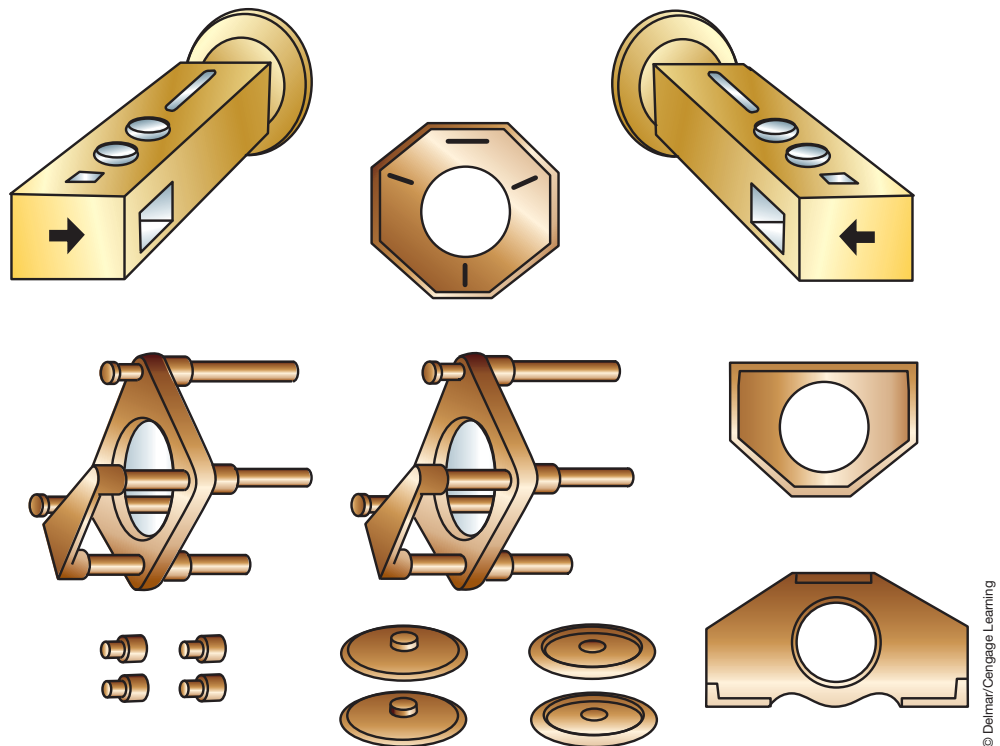


FIGURE 8-9 Typical portable mechanical headlight aiming equipment and adapters.

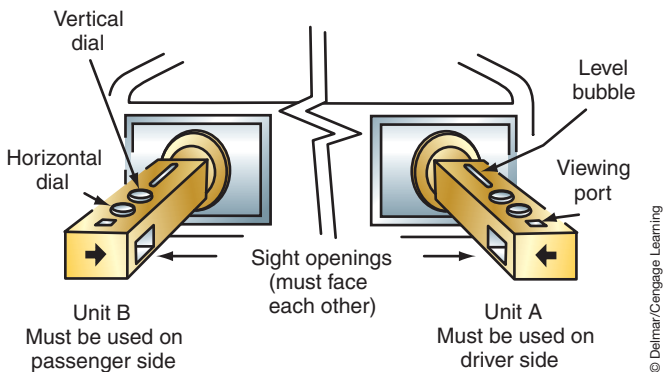


FIGURE 8-10 The aiming units attach to the headlight lens with suction cups.

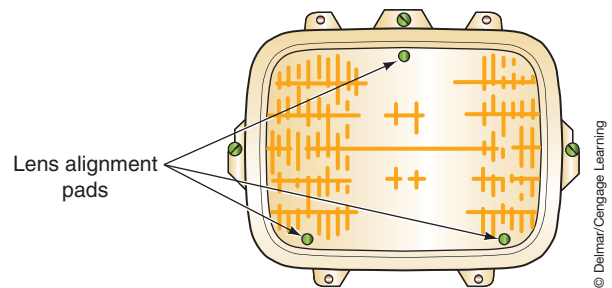
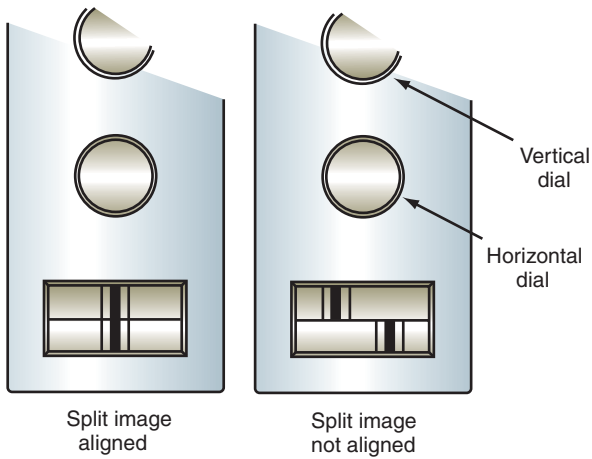
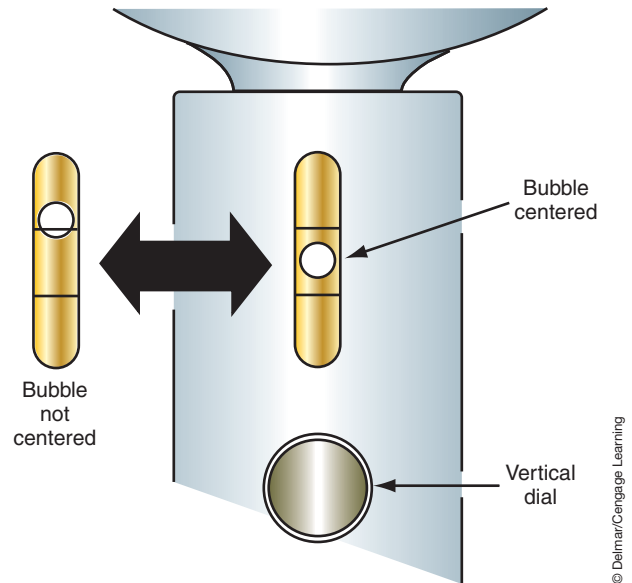


FIGURE 8-11 Headlight aiming pads.



**FIGURE 8-12** Split image target.



**FIGURE 8-13** Center the spirit level by turning the vertical aiming screw.

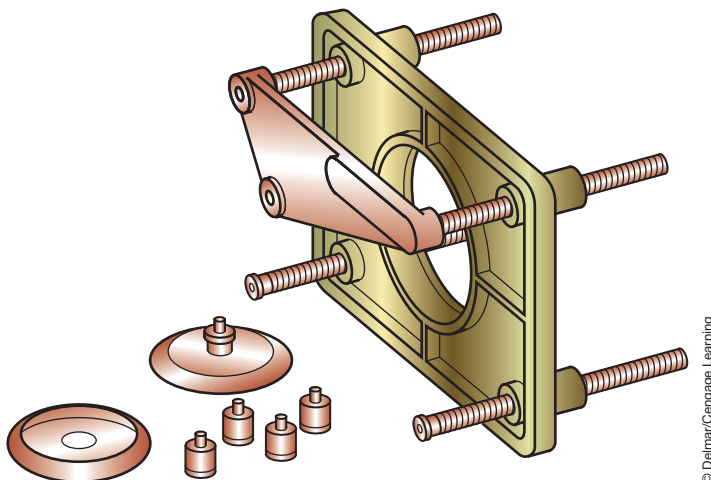
To set the vertical aim of the headlight, turn the vertical adjustment dial on the aiming unit to zero. Turn the vertical adjustment screw until the spirit level bubble is centered (Figure 8-13). Recheck the horizontal aiming on each headlight. The vertical adjustment may have altered the original adjustments.

If the vehicle is equipped with a four-headlight system, repeat the procedures for the other pair of lamps.

**Composite.** To adjust some composite and HID headlight designs, special adapters are required (Figure 8-14). Also, the lens must have headlight aiming pads to be able to use a mechanical aiming unit. The headlight assembly will have a number molded on it. The adjustment rod setting must be set to that number and locked in place. The aiming unit is attached to the headlight lens in the same manner as with sealed-beam headlights (Figure 8-15).

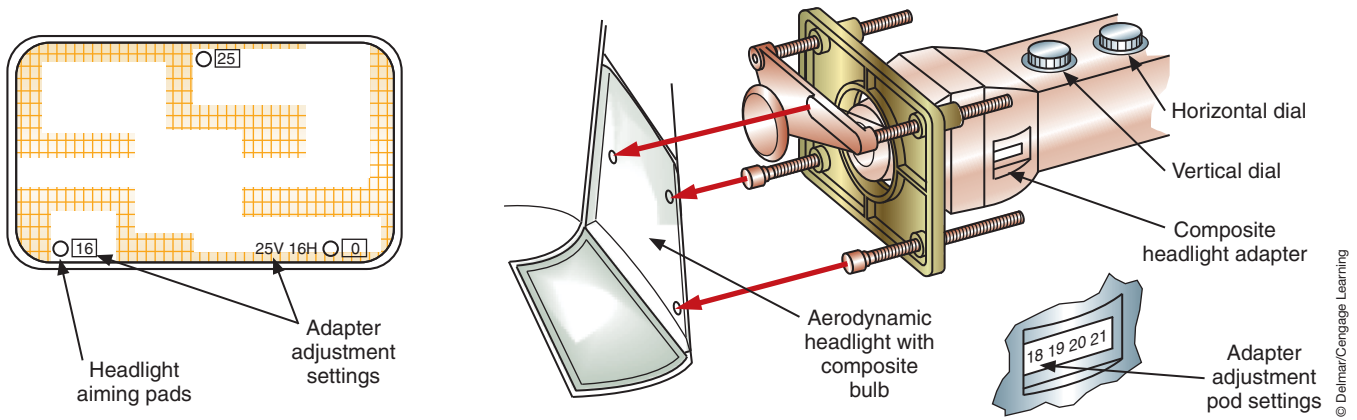
The adjustment procedure is identical to that of the sealed-beam headlights. The illustration (Figure 8-16) shows the typical location of the headlight adjusting screws.

Many composite and HID headlight designs do not have alignment pads on the lens. These systems usually adjust the beam location by moving the reflector position. Since the lens does not move, conventional headlight aimers are not used. For the most part, these

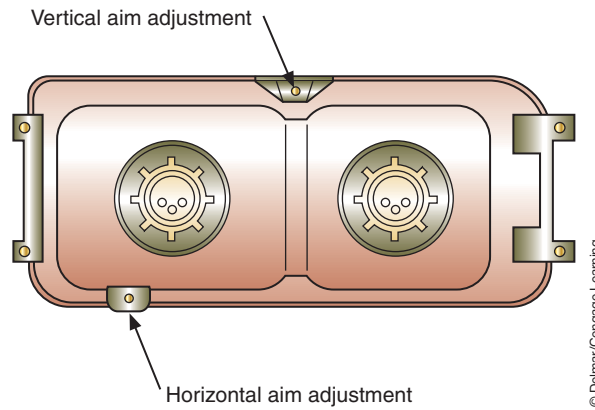


**FIGURE 8-14** Special adapter for aiming composite headlights.





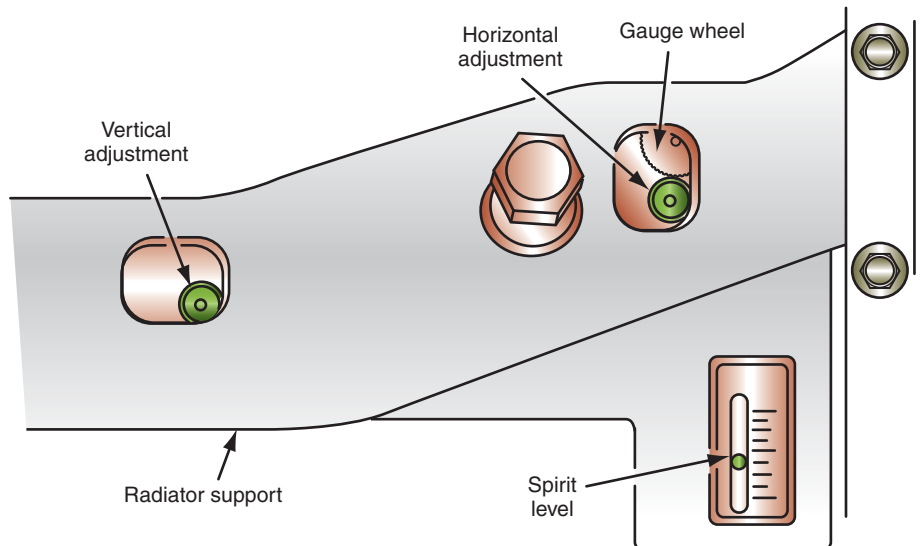
**FIGURE 8-15** Connect the aiming equipment to the headlight lens. The lens must have aiming pads.



**FIGURE 8-16** Composite headlight aiming screw locations.

systems are aimed by locating the vehicle 25 feet (7.6 m) away from a blank wall with the vehicle on a level surface. The wall is marked, based on the centerline of the vehicle; then the location of the beam on the wall is adjusted to meet manufacturer's specifications. Some manufacturers may require that the headlights be adjusted with the high beams.

Many late-model vehicles have spirit levels built into the headlamp assembly (Figure 8-17). These are not always to be used for initial headlamp adjustment. They are supplied for the



**FIGURE 8-17** Some headlight assemblies are equipped with spirit levels to provide easy adjustments to offset vehicle loads.



driver to be able to adjust his headlights based on the load in the vehicle. For example, if the trunk is loaded, the front of the vehicle is lifted and the light beam is too high. By turning the adjuster wheels until the bubble is in the middle of the level, the beam is returned to its original position. After the load is removed from the trunk, the headlights are adjusted until the bubble is returned to the middle. Whenever the headlights are adjusted, the technician should adjust the spirit level also.

## Diagnosing Dimmer- or Brighter-than-Normal Lights

The complete headlight circuit consists of the headlight switch, dimmer switch, high-beam indicator, and the headlights (Figure 8-18). Excessive resistance in these units, or at their connections, can result in lower illumination levels of the headlights.

The extra resistance can be on the insulated side or the ground side of the circuit. To locate the excessive resistance, perform a voltage drop test (Figure 8-19). Consult the wiring diagram to determine the number of connectors and switches. This will provide you with the specification for maximum voltage drop. Start at the light and work toward the battery.

All headlight systems are wired in parallel. If both headlights are dim, then the excessive resistance is in the common portions of the circuit. Dim headlights can also be the result of low generator output.

Other causes of dim lights can be the use of the wrong lamps, improper circuit routing, the addition of extra electrical loads to the circuit, and the wrong size conductors.

Brighter-than-normal lights can be the result of higher-than-specified generator output or improper lamp application. It is also possible that the dimmer switch contacts are “welded” into the high-beam position.

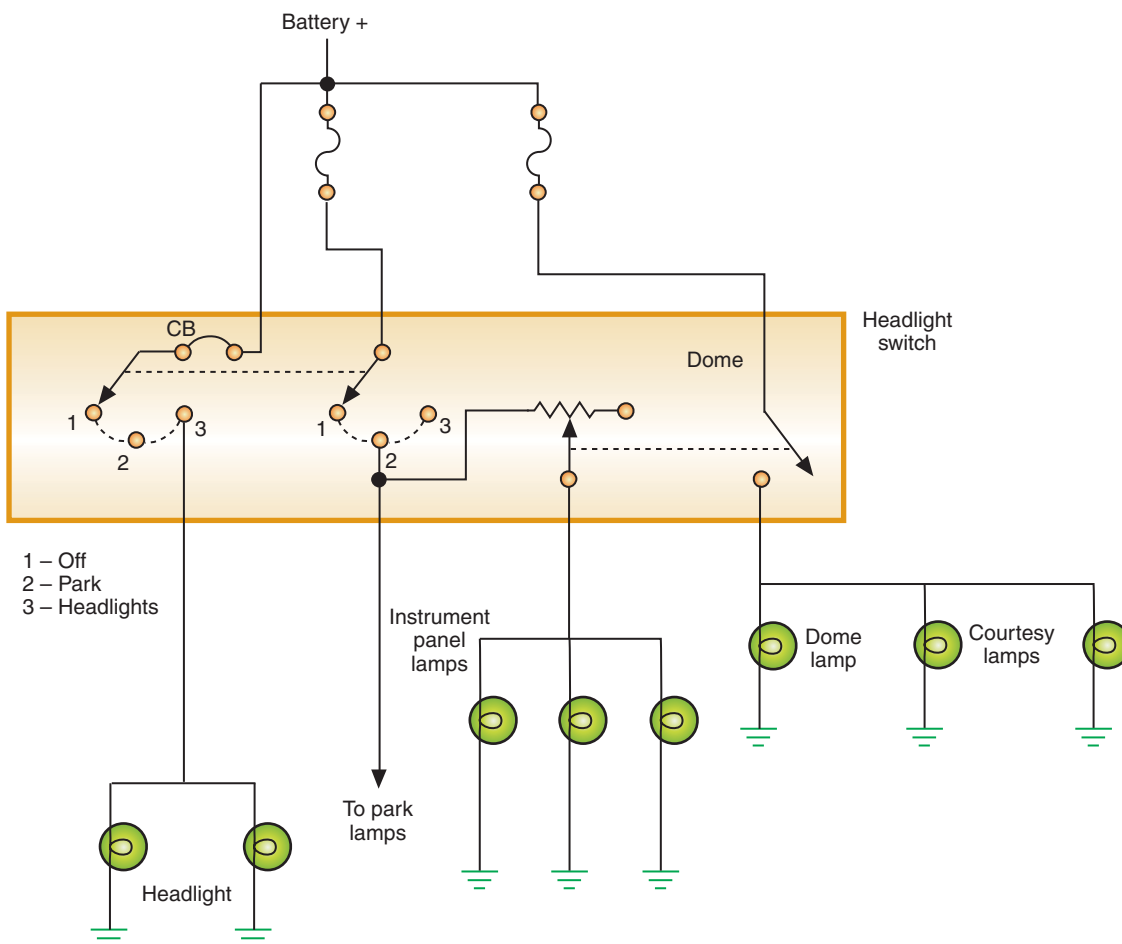


FIGURE 8-18 Headlight circuit components.



### SPECIAL TOOLS

Voltmeter  
Safety glasses

Although this procedure is being shown for the headlights, it is identical for all lighting systems. The only difference in the test results will be if the circuit uses insulated bulbs or grounded bulbs. If testing the turn signal circuit, bypass the flasher with a jumper wire.



### SERVICE TIP:

Headlights do not wear out and get dimmer with age. If one of the headlights is dimmer than the other, there is excessive voltage drop in that circuit. If a new headlight is installed, the breaking and making of the socket connection may clean the terminals enough to make a good contact. Once the new headlight is installed, it may operate properly. Do not be fooled. It was not the headlight that was at fault. It was the connection.

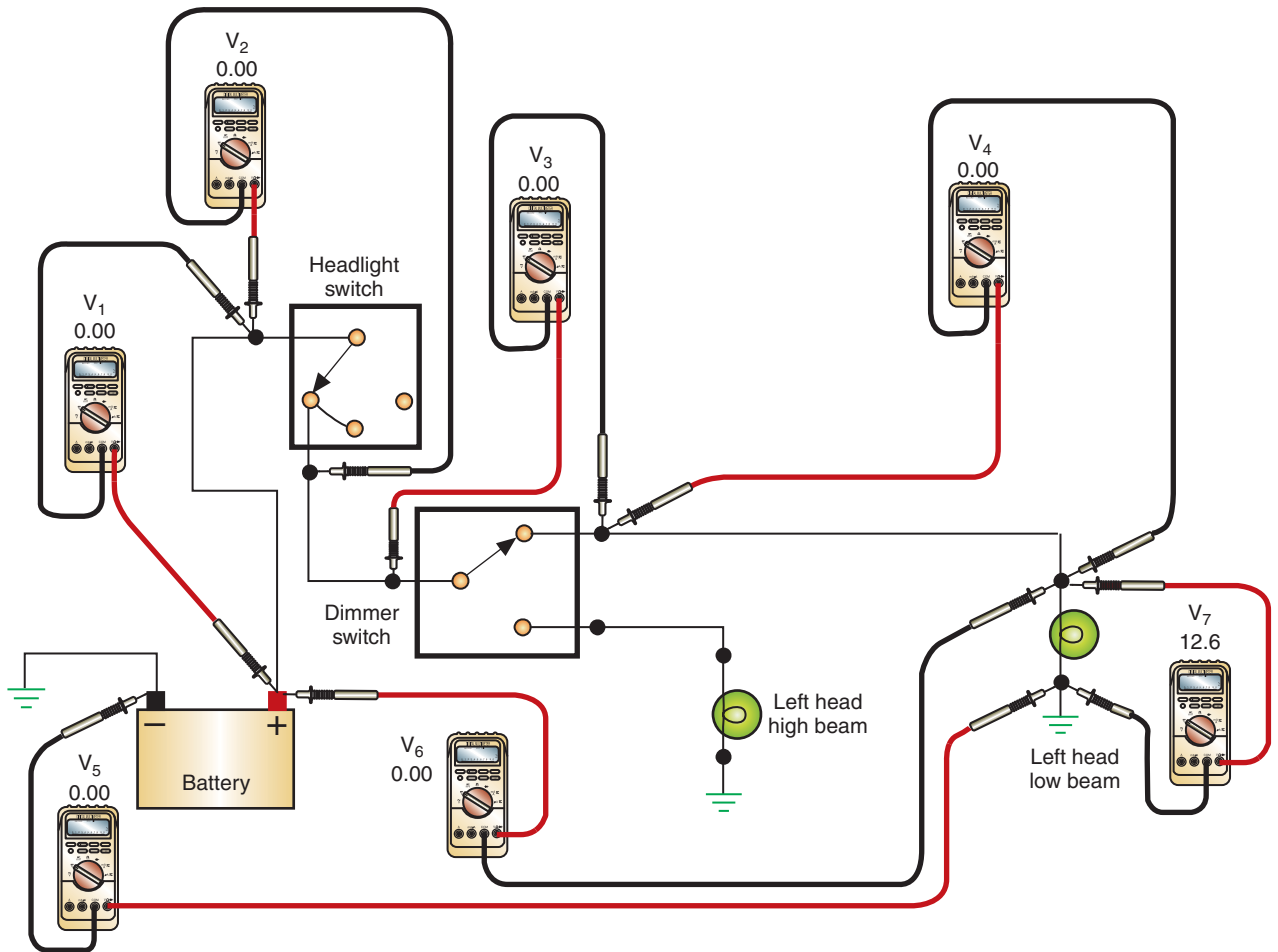


FIGURE 8-19 Voltage drop testing the headlight system.

© Delmar/Cengage Learning

**Classroom Manual**

Chapter 8, page 217

## CONCEALED HEADLIGHTS

A vehicle equipped with a concealed headlight system hides the lamps behind doors when the headlights are turned off. When the headlight switch is turned to the HEADLIGHT position, the headlight doors open. The headlight doors can be controlled either by electric motors or by vacuum. In vacuum-controlled systems, a vacuum distribution valve controls the direction of vacuum to various vacuum motors or to vent. Electrically controlled systems use either a torsion bar to open both headlight doors from a single motor or a separate motor for each headlight door.

If the electrically operated doors fail to operate, check the fuse first. If the fuse is good, check for voltage at the connection to the motor. If voltage is not present, then trace the circuit back to the switch and battery.

If there was voltage at the connector, check the ground circuit. Also, check the operation of the limit switches before condemning the motor.

Vacuum-controlled doors are tested for the presence of vacuum through the distribution valve to the vacuum motors. Use a vacuum gauge to check the amount of vacuum being applied to the motor. If vacuum is present to the motor, use a vacuum pump to check the operation of the motor.

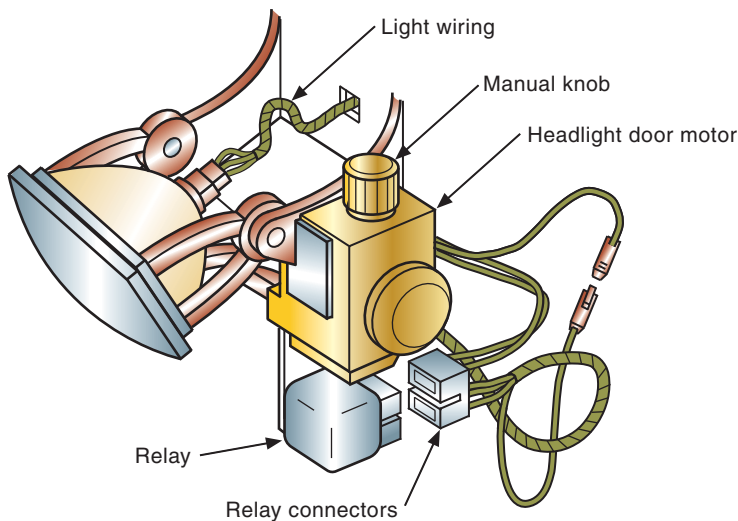
**WARNING:** Be careful not to get hands and fingers caught in the door if it should suddenly open.

All concealed headlight systems have a means of manually opening the doors. Check the service information for the correct procedure for opening the doors. Most electrical doors have a knob that is rotated to open the doors (Figure 8-20).



**SPECIAL TOOLS**

- Voltmeter
- Vacuum gauge
- Vacuum pump
- Fender covers
- Safety glasses



© Delmar/Cengage Learning

**FIGURE 8-20** Manual control knob is used to open the doors in the event of electrical problems.

In recent years, some manufacturers started using the body computer to control the operation of the concealed headlight system. On these vehicles, it may be necessary to enter body computer diagnostics to troubleshoot the system.



**SERVICE TIP:**  
Most vacuum-controlled doors use the vacuum to close the door. If the headlight doors open while the vehicle is sitting overnight, check for a leak and test the one-way check valve.

**WARNING:** Be sure the headlight switch is in the OFF position before manually opening the doors. The doors may snap open, catching fingers between the door and the vehicle body.

## HEADLIGHT SWITCH TESTING AND REPLACEMENT

The headlight switch controls most of the vehicle's lighting systems. The headlight switch will generally receive direct battery voltage to two of its terminals. Disconnect the battery before removing the headlight switch.

In the headlight switch circuit, a rheostat is used to control the instrument cluster illumination lamp brightness. Most dash-mounted headlight switches incorporate the rheostat into the switch assembly. Steering column-mounted switches may have the rheostat located on the dash.

Many customer complaints concerning the lighting systems can be the result of a faulty headlight switch. For example, dim or no instrument panel lights, dim or no headlights, dim or no parking lights, and improperly operating dome lights can all be caused by the headlight switch.

### Dash-Mounted Switches

There are many methods used to retain the headlight switch to the dash. Consult the service information of the vehicle you are working on. The following is a common method of removing the headlight switch:

**WARNING:** If the vehicle is equipped with airbags, disable the supplemental restraint system before attempting any component diagnosis or service. Failure to take the proper precautions could result in accidental airbag deployment.

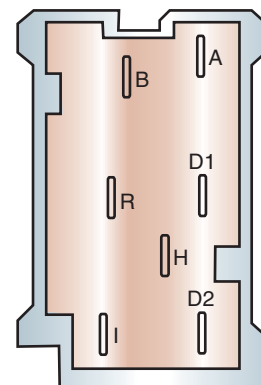
1. Place fender covers on the fenders.
2. Install a memory keeper and disconnect and isolate the battery negative cable.
3. Remove the lower cluster bezel from the instrument panel.
4. Disconnect the wire harness connector from the back of the headlamp switch.
5. Remove the fasteners that secure the headlamp switch to the back of the cluster bezel.
6. Remove the headlamp switch from the cluster bezel.

**Classroom Manual**  
Chapter 8, page 214



**SPECIAL TOOLS**  
12-volt test light  
Ohmmeter or self-powered test light  
Jumper wire  
Safety glasses  
Battery terminal pliers  
Terminal pullers

Switch terminals	Switch positions		
	Off	Park	Headlamp
B to H	No continuity	No continuity	Continuity
B to R	No continuity	No continuity	No continuity
B to A	No continuity	No continuity	No continuity
R to H	No continuity	No continuity	No continuity
R to A	No continuity	Continuity	Continuity
H to A	No continuity	No continuity	No continuity
D1 to D2	Continuity only when rheostat fully counterclockwise		
I to R	Continuity only when rheostat fully counterclockwise Then slowly rotate clockwise and test lamp should dim		



© Delmar/Cengage Learning

**FIGURE 8-21** Continuity test chart for the headlight switch.



### SERVICE TIP:

Headlights that flash on and off as the vehicle goes over road irregularities indicate a loose connection. Headlights that flash on and off at a constant rate indicate that the circuit breaker is being tripped. There is an overload in the circuit that must be traced and repaired.

Some headlight switches are retained by spring clips. Remove them by compressing the springs.

With the switch removed, it can be tested for continuity and the connector plug will serve as a test point for the lighting circuits. First, test at the connector.

The following is a typical procedure for testing the headlight switch connector on the harness side. A test light and jumper wires are used to test the circuits. This procedure would be very similar for any non-computer-controlled headlight system—just use the service information to determine the function of each terminal. In this procedure the terminals are identified as follows (Figure 8-21):

- Terminal B — battery.
- Terminal A — fuse.
- Terminal H — headlights.
- Terminal R — rear park and side marker lights.
- Terminal I — instrument panel lights.
- Terminal D1 — dome light feed.
- Terminal D2 — dome light.

Consult the service information for terminal identification for the vehicle you are working on. If this is not listed in a separate chart, you should be able to identify the circuits from the wiring diagrams.

1. Connect the 12-volt test light across terminal B and ground. The test light should light. If not, there is an open in the circuit back to the battery.
2. Connect the test light across terminal A and ground. The test light should come on. If not, repair the circuit back to the fuse panel.
3. Connect a fused jumper wire between terminals B and H. The headlights should come on. If the headlights fail to turn on, trace the H circuit to the headlights. Also, check the ground circuit side from the headlights.
4. Connect a fused jumper wire between terminals A and R. The rear lamps should illuminate. If not, trace the circuit to the rear lights. Also, check the ground return path.
5. Connect a fused jumper wire between terminals A and I. The instrument panel lights should come on. If not, trace the circuit to the panel lights.

If all the tests performed at the switch connector pass, then the problem is in the headlight switch. The chart (Figure 8-21) indicates the test results that should be obtained when testing the headlight switch for continuity for the system just discussed. Use an ohmmeter or a self-powered test light to test the switch. Most service informations will provide a table similar to Figure 8-22. If a chart is not available, use the wiring diagram to determine which terminals should or should not have continuity in the different switch positions.

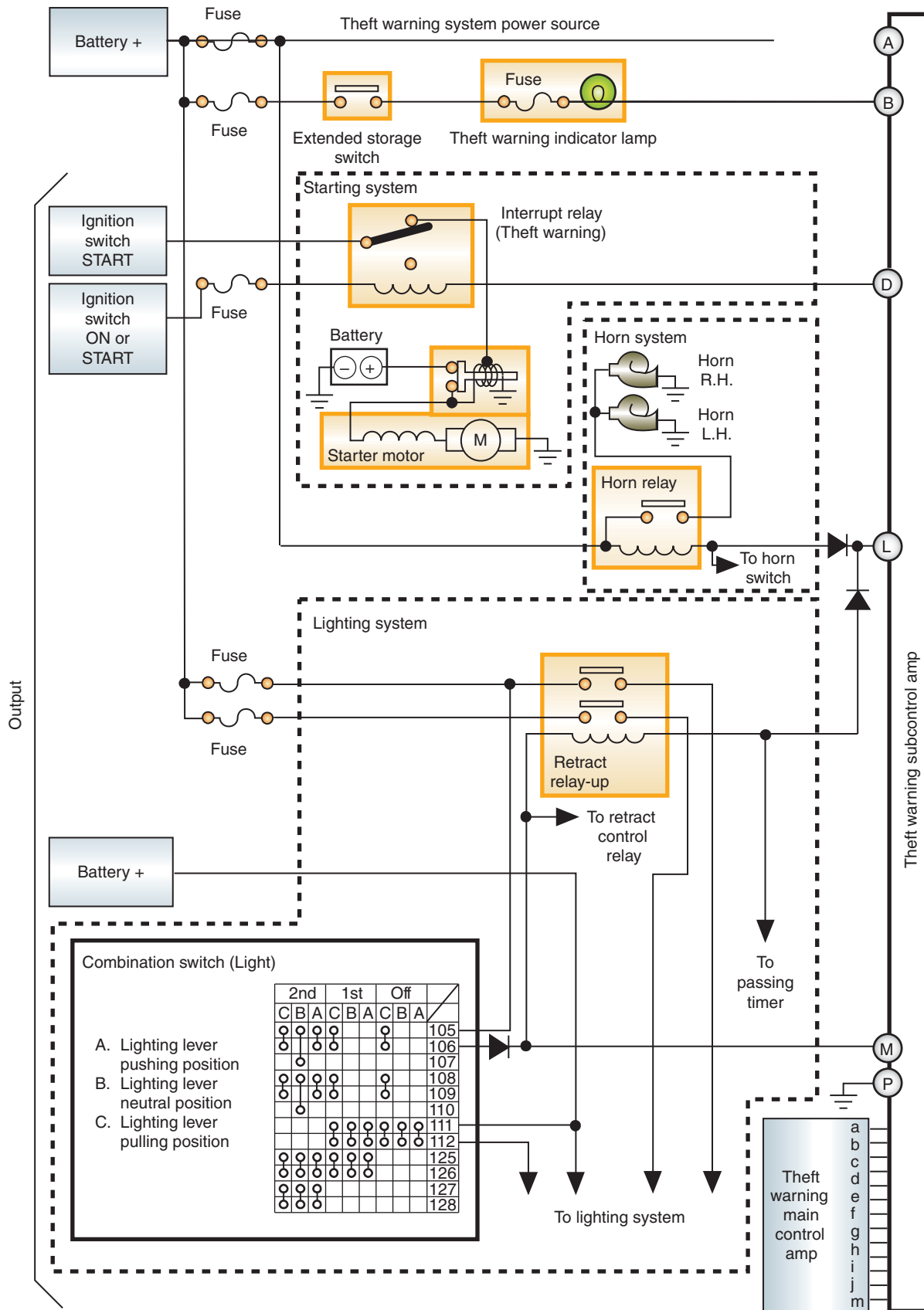


FIGURE 8-22 Using the connector to test the multifunction switch.

© Delmar/Cengage Learning



© Delmar/Cengage Learning

FIGURE 8-23 Multifunction switch.

## Steering Column–Mounted Switches

On some vehicles, it is possible to test the steering column–mounted switch without removing it. The test is conducted at the connector at the base of the column (Figure 8-22). However, on some models, it is necessary to remove the column cover and/or the steering wheel to gain access.

A common procedure for removing and testing the **multifunction switch** is shown in Photo Sequence 16. The switch is called a multifunction switch because it can have a combination of any of the following switches in a single unit: headlights, turn signal, hazard, dimmer switch, horn, and flash to pass (Figure 8-23).

## DIMMER SWITCH TESTING AND REPLACEMENT

The **dimmer switch** is connected in series within the headlight circuit and controls the current path for high and low beams. The dimmer switch is located either on the floor board next to the left kick panel or on the steering column. Testing of the switch is done by using a set of jumper wires to bypass the switch (Figure 8-24). If the headlights operate with the switch bypassed, the switch is faulty. This is a common problem with older vehicles that have the dimmer switch on the floor board because the switch is subjected to damage due to rust, dirt, and so on.

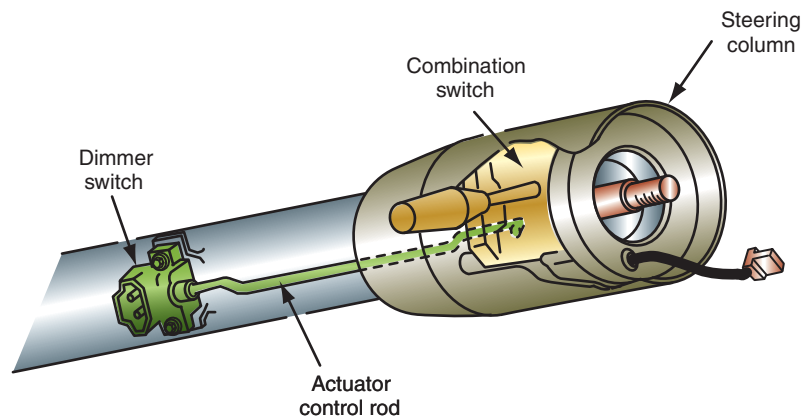
### Classroom Manual

Chapter 8, page 216



### SPECIAL TOOLS

- Jumper wires
- Safety glasses
- Battery terminal pliers
- Terminal pullers



© Delmar/Cengage Learning

FIGURE 8-24 Steering column mounted dimmer switch.



## REMOVAL AND TESTING OF THE MULTIFUNCTION SWITCH

All photos in this sequence are © Delmar/Cengage Learning.



**P16-1** Tools required to remove and test the multifunction switch: fender covers, battery terminal pliers, terminal pullers, assorted combination wrenches, torx drivers, and ohmmeter.



**P16-2** Place the fender covers around the battery work area.



**P16-3** Loosen the negative battery clamp bolt and remove the clamp using terminal pliers. Place the battery cable where it cannot contact the battery.



**P16-4** Remove the shroud retaining screws and remove the lower shroud from the column.



**P16-5** If needed to gain access to the upper shroud, loosen the steering column attaching nuts. Do not remove the nuts.



**P16-6** Lower the steering column enough to remove the upper shroud.



**P16-7** Remove the turn signal lever by slightly rotating the outer end of the lever then pulling straight out on the lever. Some levers may be attached with fasteners.



**P16-8** Peel back the foam shield from the turn signal switch.



**P16-9** Disconnect the turn signal switch electrical connectors.

## PHOTO SEQUENCE 16 (CONTINUED)



**P16-10** Remove the screws attaching the turn signal switch to the lock cylinder assembly.



**P16-11** Disengage the switch from the lock assembly.



**P16-12** Use the ohmmeter to test the switch. Check for continuity from terminal 15 to 13 when the dimmer switch is in the low-beam position.



**P16-13** With the switch in the low-beam position, the circuit should be open between terminals 15 and 12.



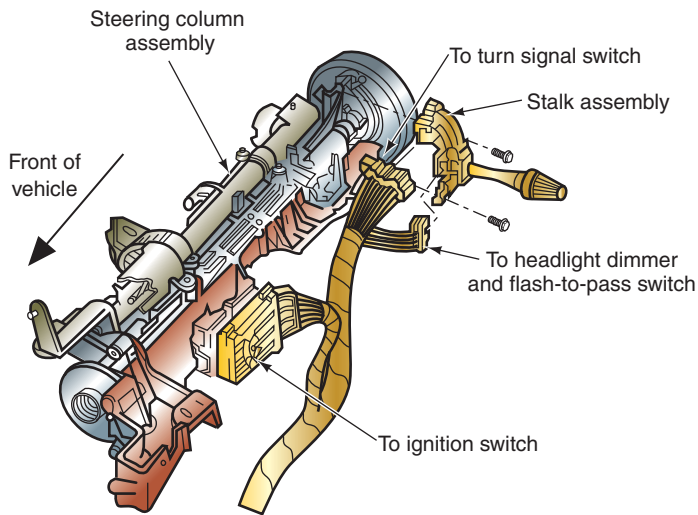
**P16-14** The circuits between terminals 196 and 13, and 196 and 12, should be open in the low-beam position.



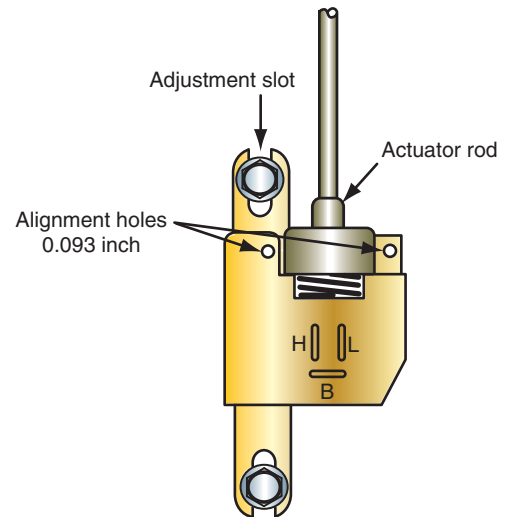
**P16-15** With the switch in the high-beam position, continuity should be between terminals 15 and 12. Circuits 15 to 13, 196 to 13, and 196 to 12 should be open.



**P16-16** When the dimmer switch is placed in the flash to pass position, there should be a closed circuit between terminals 196 and 12, and an open circuit between 196 and 13.



**FIGURE 8-25** Dimmer switch incorporated into the multifunction switch.



**FIGURE 8-26** Insert a dowel into the alignment holes to adjust the dimmer switch.

© Delmar/Cengage Learning

© Delmar/Cengage Learning

## Floor-Mounted Switches

Removal and replacement of the floor-mounted dimmer switch is done by first pulling back on the floor mat to expose the switch. Next, disconnect the wire plug and remove the hold-down fasteners. Install the new dimmer switch and relocate the mat so it does not interfere with switch operation.

## Steering Column–Mounted Switches

The steering column–mounted dimmer switch can be operated by an actuator control rod from the lever to a remotely mounted switch (Figure 8-24). Another style incorporates the dimmer switch into the multifunction switch (Figure 8-25).

To remove the remote switch, first place fender covers on the fenders of the vehicle and disconnect the battery negative cable. Disconnect the wire connector at the switch. Remove the two switch mounting screws and disengage the switch from the actuator rod.

When installing the switch, make sure the actuator rod is firmly seated into the switch. During the installation, adjust the position of the switch so that all actuator rod slack is taken up. If the switch has alignment holes, compress the switch until two appropriately sized dowels can be inserted into the alignment holes (Figure 8-26). While applying a slight rearward pressure, install and tighten the mounting bolts.

When the switch is adjusted properly, it will click when the lever is lifted and again when it is returned to its downward position. The second click should occur just before the stop.

If the dimmer switch is a part of the multifunction switch, follow the general procedure shown in Photo Sequence 16.

To reinstall the multiswitch, reverse the procedure. Torque the steering column attaching nuts to the amount specified in the service information.

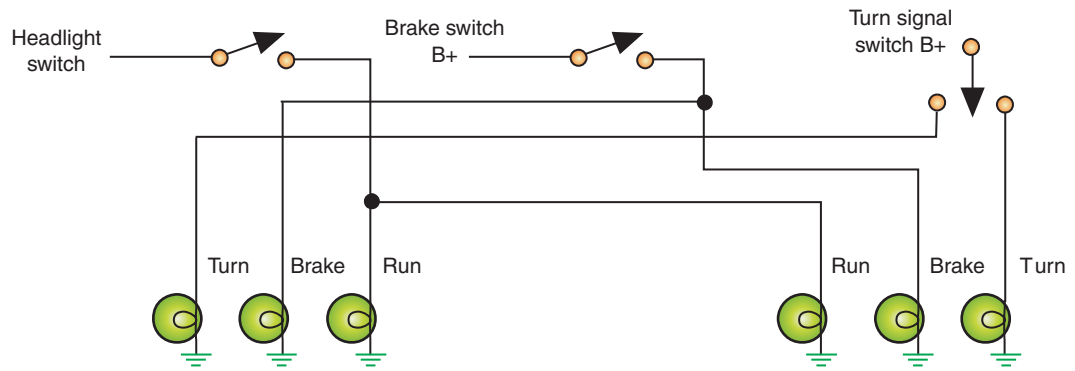
Use a memory keeper before disconnecting the battery.

## TAILLIGHT ASSEMBLIES

In a three-bulb taillight system, the brake lights are controlled directly by the brake light switch (Figure 8-27). The brake lights on both sides of the vehicle are wired in parallel. Most brake light systems use dual-filament bulbs that perform multifunctions. In this type of circuit, the brake lights are wired through the turn signal and hazard switches (Figure 8-28).

**Classroom Manual**  
Chapter 8, page 221





**FIGURE 8-27** Three-bulb taillight circuit has individual control for each bulb.

© Delmar/Cengage Learning



### CAUTION:

Using the wrong type of lamp for the socket and application can result in “crazy lights.” This is a result of feedback caused by the incorrect bulb (Figure 8-32).

If all of the taillights do not operate, check the condition of the fuse. If it is good, use a voltmeter to test the circuit. With the headlight switch in the PARK position (first detent), check for voltage at the last common connection between the switch and the lamps. If battery voltage is present, then the problem is in the individual circuits from that connector to the lamps. If no battery voltage is present, test for voltage from the switch terminal. If no voltage is present at this terminal yet the headlights operate when in the ON position, replace the switch. If battery voltage is present, the problem is between the switch and the last common connection. If there was no voltage present at the switch terminal, check for battery voltage into the switch.

Most taillight bulbs can be replaced without removal of the lens assembly. The bulb and socket are removed by twisting the socket slightly and pulling it out of the lens assembly (Figure 8-29). To remove the bulb from the socket, push in on the bulb slightly while turning it. When the lugs align with the channels of the socket, pull the bulb from the socket (Figure 8-30).

If the bulb is a blade base-type bulb, pull it straight out of the socket without twisting. On all bulb types it is a good practice to use an oil-free rag or wear nylon gloves to grasp the bulb. This will keep oil off of the bulb but also will protect you if the bulb should break.

The illustration (Figure 8-31) shows how the lens assembly is fastened to the vehicle body. Remove the attachment nuts from the back of the assembly to remove it.

### Classroom Manual

Chapter 8, pages 221, 222



### SPECIAL TOOLS

12-volt test light  
Steering wheel puller  
Lock ring compressor  
Safety glasses

## Turn Signals and Brake Lights

To test the turn signal switches, use a 12-volt test light to probe for voltage into and out of the switch. The ignition switch must be in the RUN position for the circuit to operate. If voltage is present on the input side of the switch but not on the output side, the switch is faulty.

Check brake light operation through the turn signal switch in the same manner. Also, check the brake light switch for proper adjustment and operations (Figure 8-33).

Many early vehicles use a turn signal switch that is separate from the multifunction switch. The steering wheel will have to be removed to gain access to the turn signal switch on these vehicles. The following procedure is a common method of turn signal switch replacement:

1. Place the fender covers on the fenders.
2. Install a memory keeper and disconnect the battery negative cable.



**WARNING:** If the vehicle is equipped with an air bag system, wait the recommended amount of time before removing any other components. Fifteen minutes or more may be required to discharge the capacitors that are used to fire the air bags.

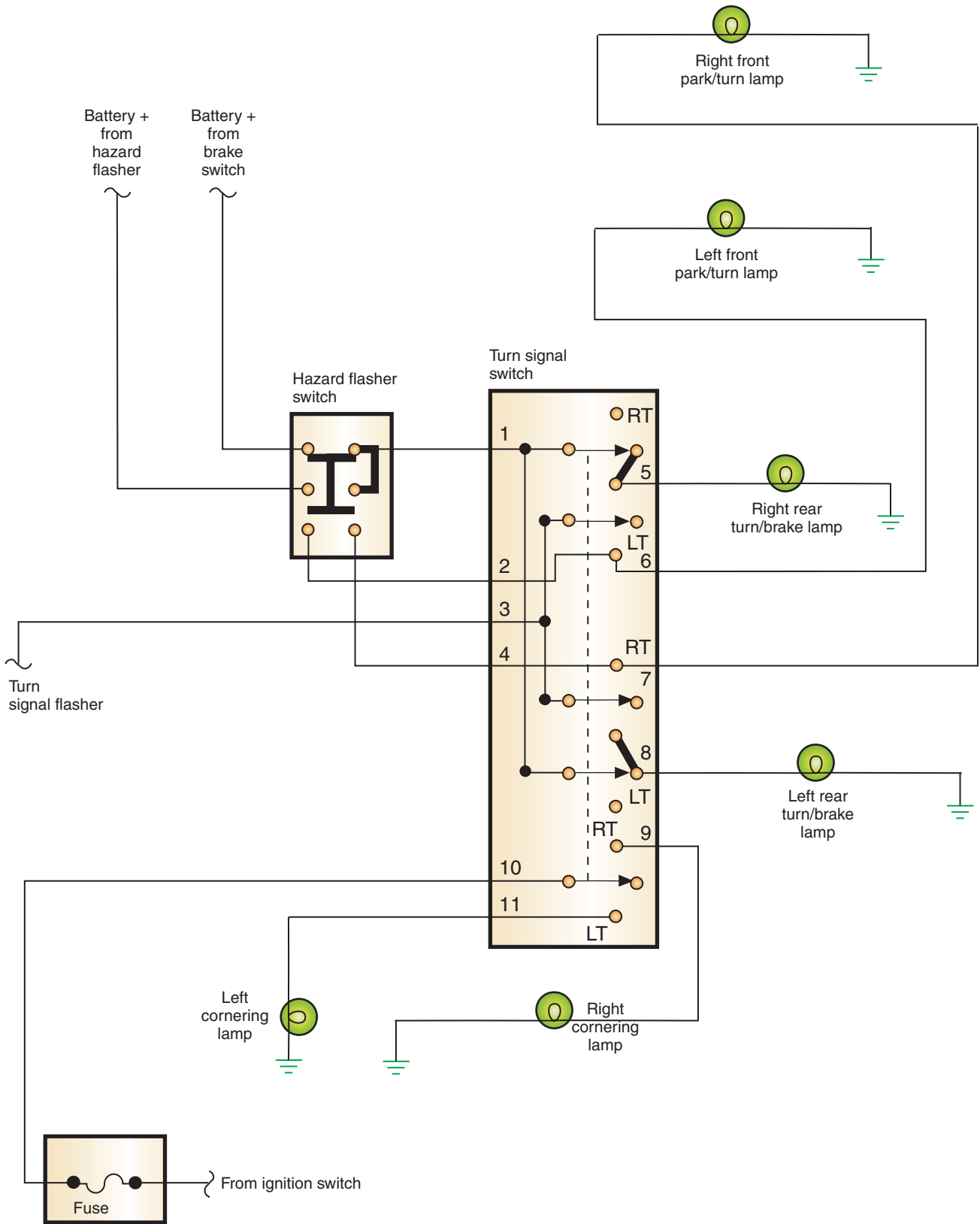
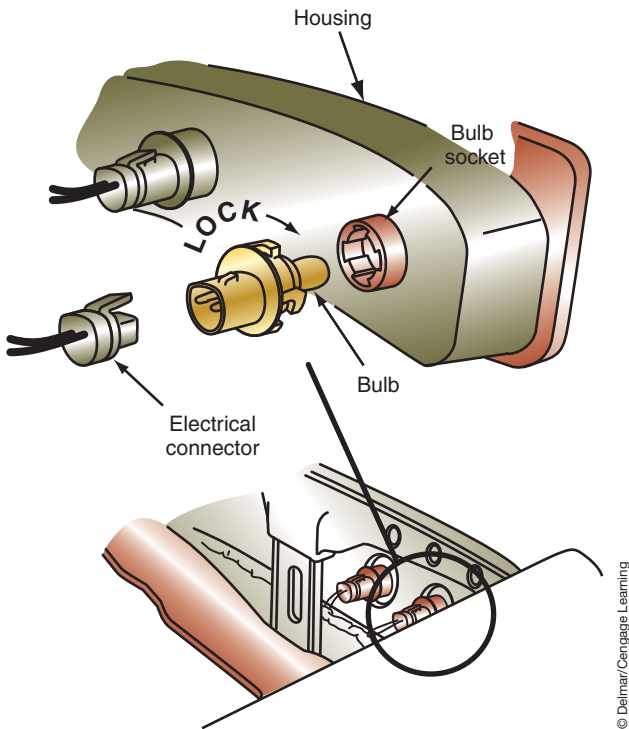
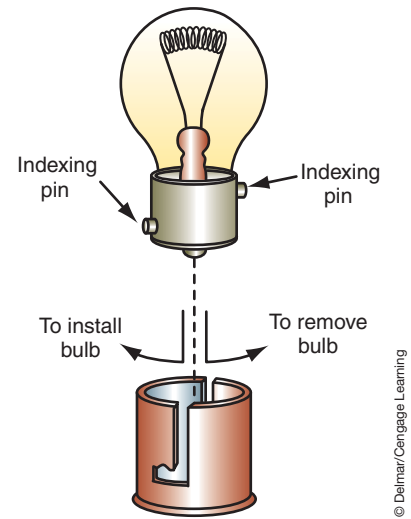


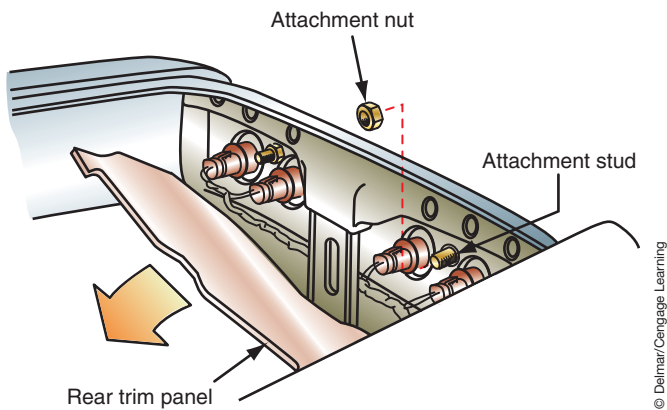
FIGURE 8-28 Turn signal switch used in a two-bulb taillight circuit.



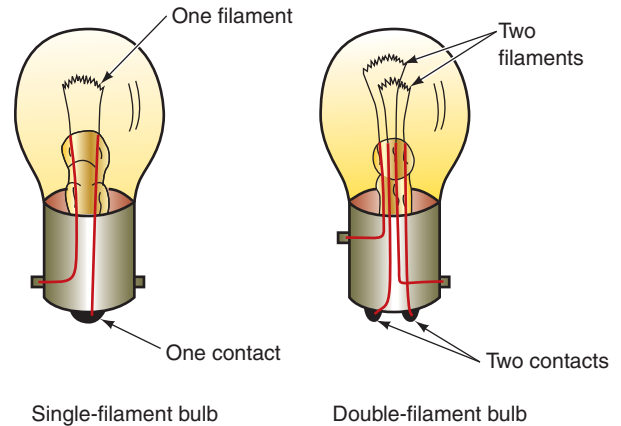
**FIGURE 8-29** Bulb and socket removal from the taillight lens assembly.



**FIGURE 8-30** Removing the bulb from the socket.



**FIGURE 8-31** Taillight lens assembly.

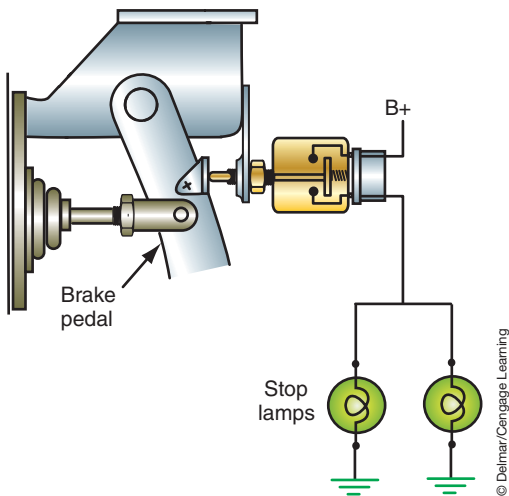


**FIGURE 8-32** If the single-filament bulb is mistakenly installed into a socket designed for dual filament, the single contact of the bulb will short across the two contacts of the socket. This will result in lighting circuits operating when they are not suppose to.

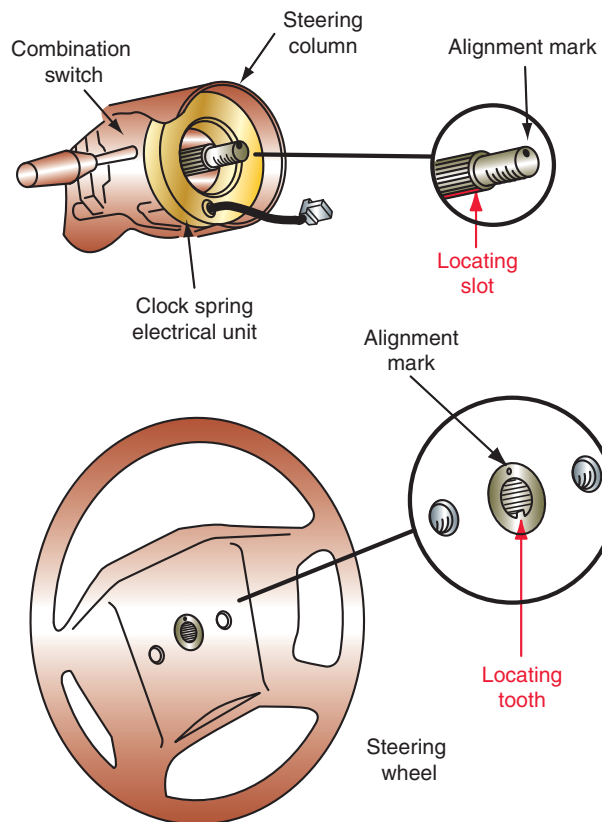
Most turn signal switches receive their voltage from the ignition switch when it is in the RUN position only. This prevents the turn signals from operating while the ignition switch is in the OFF position.

3. Remove the steering column trim.
4. Remove the horn pad from the steering wheel.
5. If equipped, remove the steering shaft nut and horn collar (Figure 8-34).
6. Use a suitable puller to remove the steering wheel.
7. If needed, use a suitable compressor to compress the preload spring to the lock plate (Figure 8-35). Compress the spring only enough to remove the snap ring.
8. Use a pick and a small, flat-blade screwdriver to remove the snap ring.
9. Remove the lock plate, horn contact carrier, and spring.
10. Remove the bolts at the upper steering column support and the upper mounting bracket from the column.

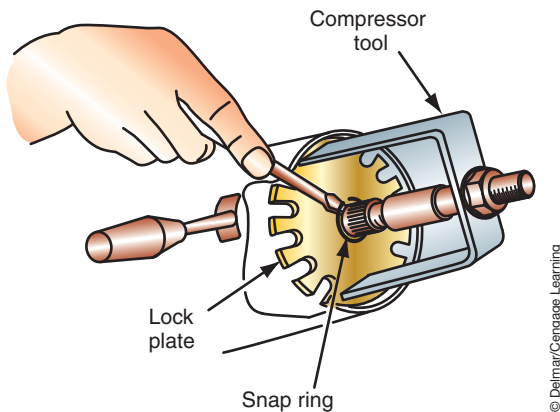




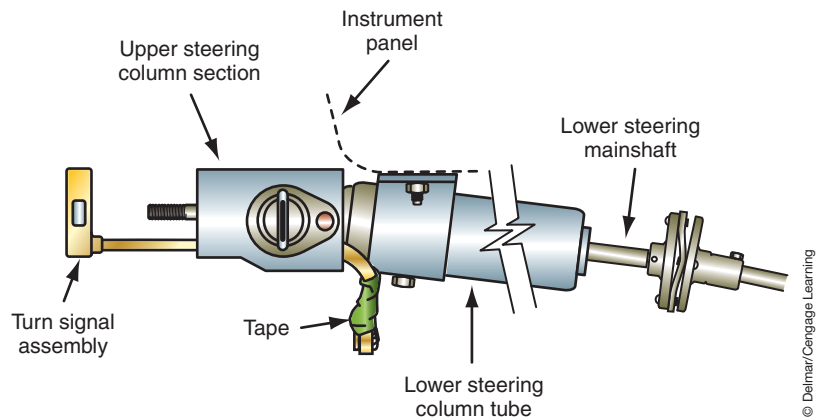
**FIGURE 8-33** Typical brake light switch operation. Check for continuity in both positions. Should be open when at rest and closed when the pedal is depressed.



**FIGURE 8-34** Steering wheel attachment.



**FIGURE 8-35** To remove the snap ring, use the compressing tool to relieve the pressure against the snap ring.



**FIGURE 8-36** Tape the turn signal connector to make removal easier.

11. Disconnect the turn signal wiring connector.
12. Wrap tape around the wire and connector (Figure 8-36).
13. Remove the hazard warning knob from the column.
14. Remove the switch retaining screws and remove the switch.

On vehicles equipped with cornering lights, the turn signal switch has an additional set of contacts that operate the cornering light circuit only. The contacts can receive voltage from either the ignition switch or the headlight switch. If the ignition switch provides the power, the cornering lights will be activated any time the turn signals are used. If the contacts receive the voltage from the headlight switch, the cornering lights do not operate unless the headlight switch is in the PARK or HEADLIGHT position.



**SERVICE TIP:**

Two-bulb system switches also control some brake light functions through a complex system of contacts. Many brake light problems are caused by worn contacts in the turn signal switch.



**SPECIAL TOOLS**

Jumper wires  
Safety glasses

The ignition switch must be in the RUN position for the turn signal circuit to be powered.

Not all flashers are located in the fuse box. Use the component locator to find where the flasher is installed.



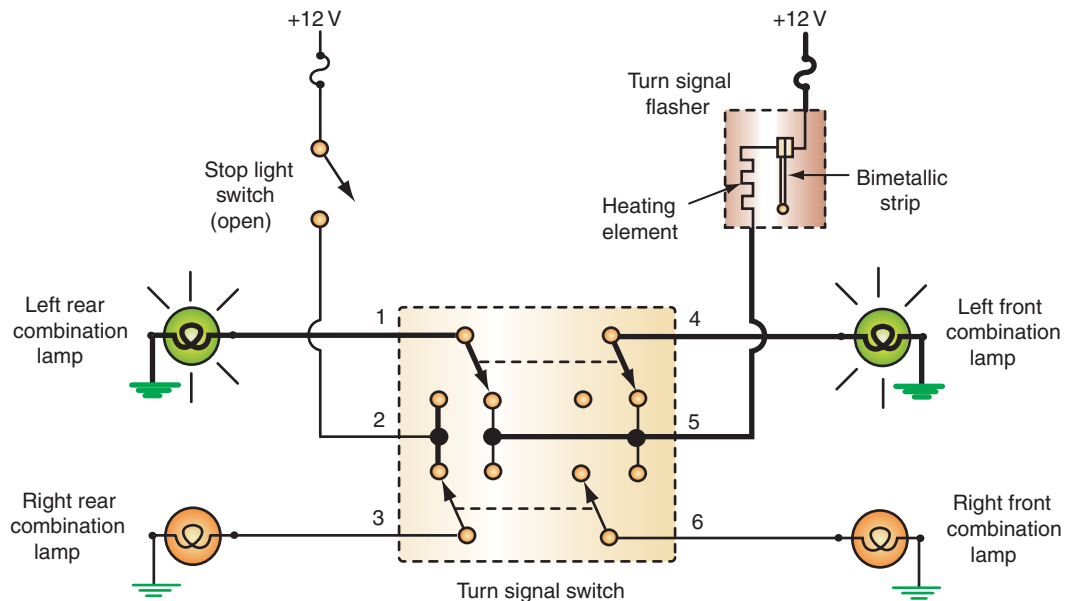
**SERVICE TIP:**

If the turn signals operate properly in one direction but do not flash in the other, the problem is not in the flasher unit. A burned-out lamp filament will not cause enough current to flow to heat the bimetallic strip sufficiently to cause it to open. Thus the lights do not flash. Locate the faulty bulb and replace it.

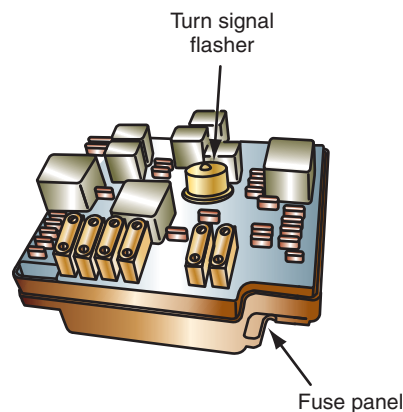
**Flashers.** The flasher uses a bimetallic strip and a heating coil to flash the turn signals (Figure 8-37). The most common complaints that are attributable to the flasher is the speed of the flashing rate. If the flasher is of the wrong type and rating, the amount of time required to heat the coil will differ from what the manufacturer designed into the circuit. Also, newer flashers that use electronic circuits will flash at an increased speed if one of the turn signal bulbs is burned out or the circuit is defective. If the flasher is rated higher than required, the flashing rate is reduced because it takes longer for the current to heat the coil.

Check the size and type of light bulbs in the circuit. Use only the lamp size recommended by the manufacturer. If these checks do not correct the problem, test the generator output. Voltage output that is higher or lower than specified may cause the flasher rate to be incorrect. If the charging system output is within specifications, check for excessive resistance in the turn signal circuit. Check both sides of the circuit.

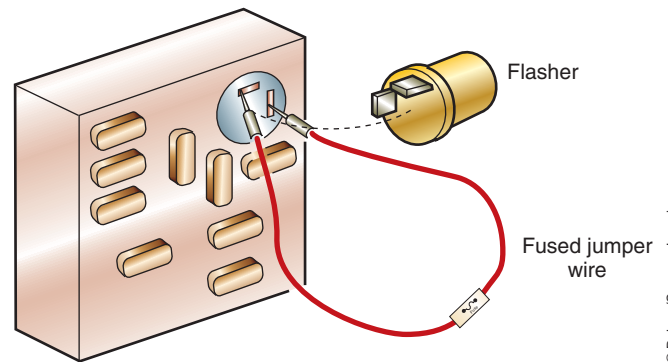
If none of the turn signals operate, check the fuse. Next, check the flasher. Remove the flasher from the fuse box (Figure 8-38). Connect a jumper wire across the fuse box terminals (Figure 8-39). If the turn signal lamps come on with the lever in either indicator position, the flasher is faulty. If the lights still do not illuminate, test the turn signal switch.



**FIGURE 8-37** As current flows through the heating element, the bimetallic strip will bend and break the circuit. This happens several times a minute to provide for turn signal flashing.



**FIGURE 8-38** Many manufacturers locate the flasher unit in the fuse panel.



**FIGURE 8-39** Connecting jumper wires across the terminals to bypass the flasher unit.

## INTERIOR LIGHTS

Interior lighting includes courtesy lights, map lights, and instrument panel lights.

### Courtesy Lights

Courtesy lights operate from the headlight and door switches. They receive their power source directly from a fused battery connection. The switches can control either the ground circuit (Figure 8-40) or the insulated circuit (Figure 8-41). The courtesy lights may also be activated from the headlight switch by turning the switch knob to the extreme counterclockwise position. The contacts in the switch close and complete the circuit.

Figure 8-42 provides a systematic approach to troubleshooting courtesy lights. Follow the steps in proper order to locate the fault.

If all the lights of the circuit do not light, begin by checking the fuses. If the fuse is good, then use a voltmeter to check for battery voltage at the last common connection. If voltage is present at the fuse box but not at the common connection, the problem is between these two points. If battery voltage is present at the common connection, trace the individual circuits until the cause(s) for the open is located.

If the courtesy lights do not come on when only one of the doors is opened but do come on when any of the other doors are opened, the problem is in the affected door's switch. In order to check the switch and circuit, bypass the switch with a jumper wire. If the lights come on with the switch bypassed, it is a faulty switch. If the lights do not come on with the switch bypassed, there is a problem in the circuit.

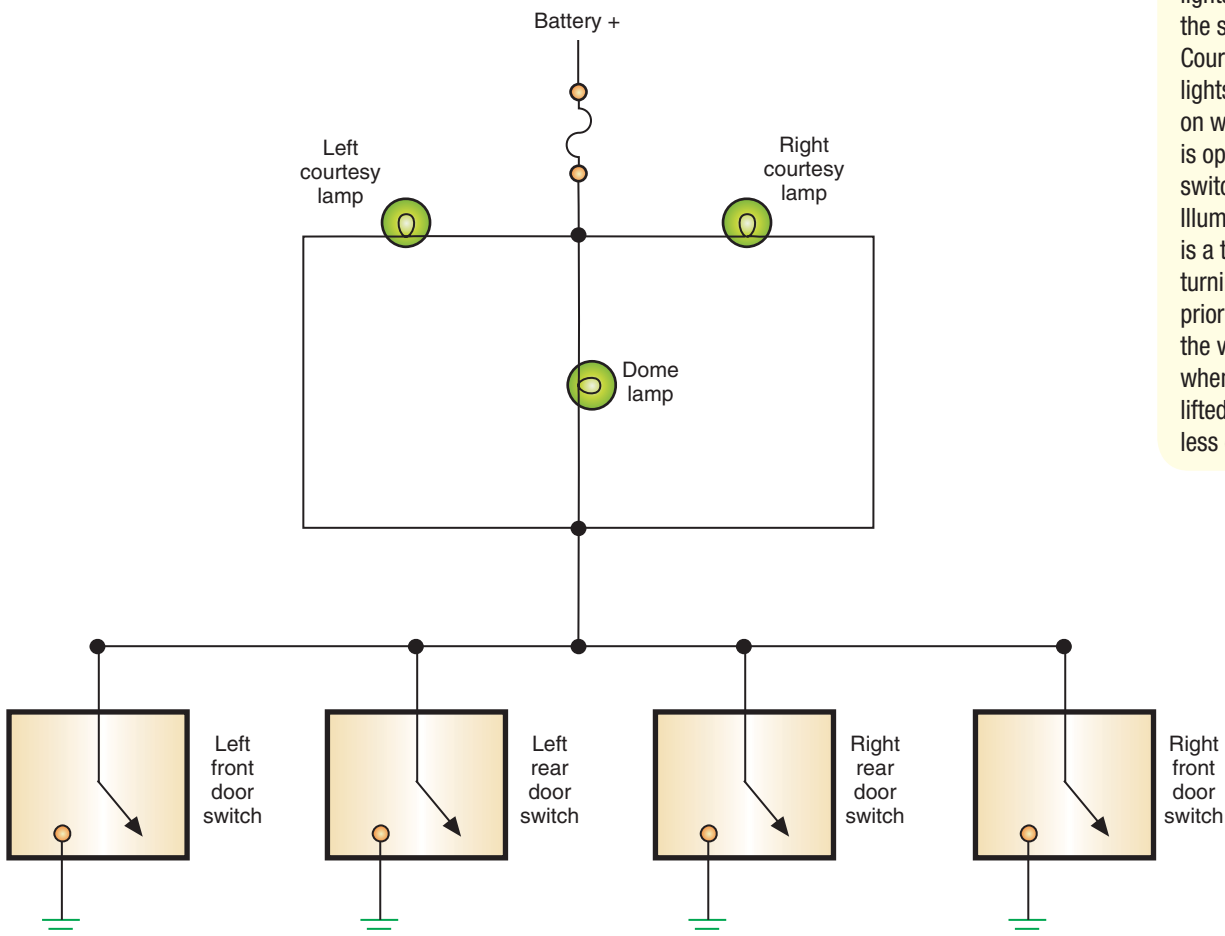


FIGURE 8-40 Courtesy lights using ground side switches.



### SPECIAL TOOLS

Voltmeter  
Safety glasses

Any time a blown fuse is found, the cause of the circuit overload must be traced.

Courtesy lights and illuminated entry lights usually use the same bulbs. Courtesy lights are lights that come on when the door is open or the switch is turned on. Illuminated entry is a term used for turning on lamps prior to entering the vehicle, such as when the handle is lifted or remote key-less entry is used.

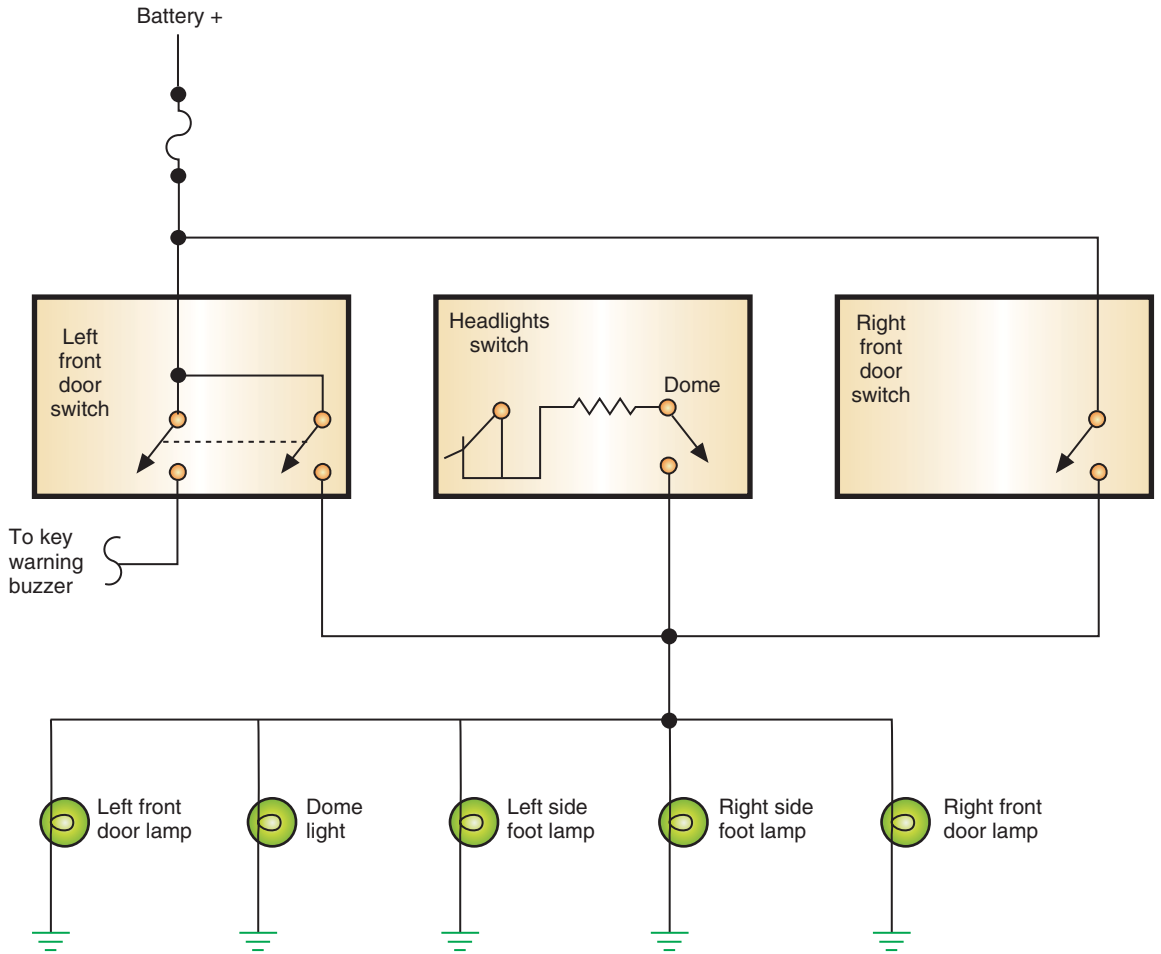


FIGURE 8-41 Courtesy lights using insulated side switches.

COURTESY LAMPS DO NOT TURN ON WHEN ONE DOOR IS OPENED  
OK WHEN OTHER DOORS ARE OPENED

Test step	Result	Action to take
A0 <b>Verify condition</b>		Go to A1
A1 <b>Check power</b> Check for power at door switch	<del>OK</del>	Check the power circuit back to fuse
	OK	Go to A2
A2 <b>Check the door switch</b> Check the door switch for proper operation	<del>OK</del>	Replace the switch
	OK	Check circuit from switch to lamp

FIGURE 8-42 A diagnostic chart for the courtesy light system.

COURTESY LAMPS DO NOT COME ON WHEN HEADLAMP SWITCH  
IS TURNED COUNTERCLOCKWISE TO STOP

Test step	Result	Action to take
B0 <b>Verify condition</b>		Go to B1
B1 <b>Check operation of door switches</b> Check to see if courtesy lamps operate from door switches	<del>OK</del>	Go to chart C
	OK	Go to B2
B2 <b>Check for power</b> Check for power at headlamp switch	<del>OK</del>	Check circuit back to fuse
	OK	Go to B3
B3 <b>Check for continuity</b> Check continuity of headlamp switch	<del>OK</del>	Replace headlamp switch
	OK	Check circuit from switch to lamp

COURTESY LAMP DOES NOT COME ON WHEN  
ALL DOORS ARE OPENED

Test step	Result	Action to take
C0 <b>Verify condition</b> Vehicle with only one courtesy lamp Vehicle with more than one courtesy lamp		Go to C1 Go to C2
C1 <b>Check operation of fuse circuit</b> Check operation of other circuits that share the same fuse	<del>OK</del>	Go to C4
	OK	Go to C2
C2 <b>Check for power</b> Check for power at the bulb	<del>OK</del>	Replace bulb
	OK	Go to C3
C3 <b>Check for continuity</b> Check continuity of bulb	<del>OK</del>	Replace bulb
	OK	Check bulb ground
C4 <b>Check fuse</b> Check continuity of fuse	<del>OK</del>	Replace fuse
	OK	Go to C5
C2 <b>Check for power</b> Check for power through the fuse	<del>OK</del>	Check power feed circuit
	OK	Check for open circuit between fuse and common point in lamp circuit

© Delmar/Cengage Learning

FIGURE 8-42 (continued)



**SPECIAL TOOLS**

- Voltmeter
- Ohmmeter
- Safety glasses



**CAUTION:**

Be careful when testing the printed circuit. Do not touch the circuit paths with your fingers. Do not scratch the lamination with the test probes. Doing so may destroy a good circuit board.

## Instrument Cluster and Panel Lights

The power source for the instrument panel lights is provided through the headlight switch. The contacts are closed when the headlight switch is located in the PARK or HEADLIGHT position. The current must flow through a variable resistor (rheostat) that is either a part of the headlight switch or a separate dial on the dash. The resistance of the rheostat is varied by turning the knob. By varying the resistance, changes in the current flow to the lamps control the brightness of the lights.

Test for voltage output from the headlight switch to determine if the switch is operating properly. Vary the amount of resistance in the rheostat while observing the voltmeter. The voltage reading from the rheostat should vary as the knob is turned. If voltage is present to the printed circuit, check the ground.

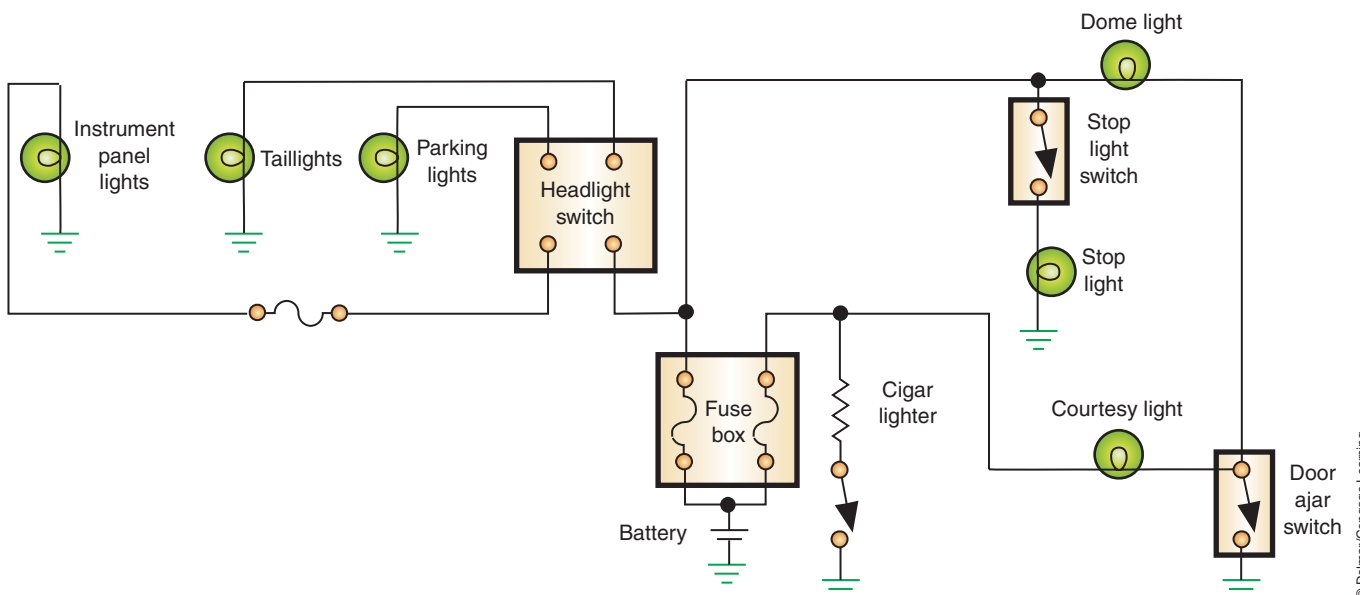
If all connections are good, remove the dash and test the printed circuit board. Use an ohmmeter to check for opens and shorts in the printed circuit board from the connector plug to the lamp sockets. If the printed circuit is bad, it must be replaced. There are no repairs to the board.

## LIGHTING SYSTEM COMPLEXITY

Today's vehicles have a sophisticated lighting system and electrical interconnections. It is possible to have problems with lights and accessories that cause them to operate when they are not supposed to. This is through a condition called **feedback**. Feedback occurs when electricity seeks a path of lower resistance. This alternate path operates another component than the one intended. If there is an open in the circuit, electricity will seek another path to follow. This may cause any lights or accessories in that path to turn on.

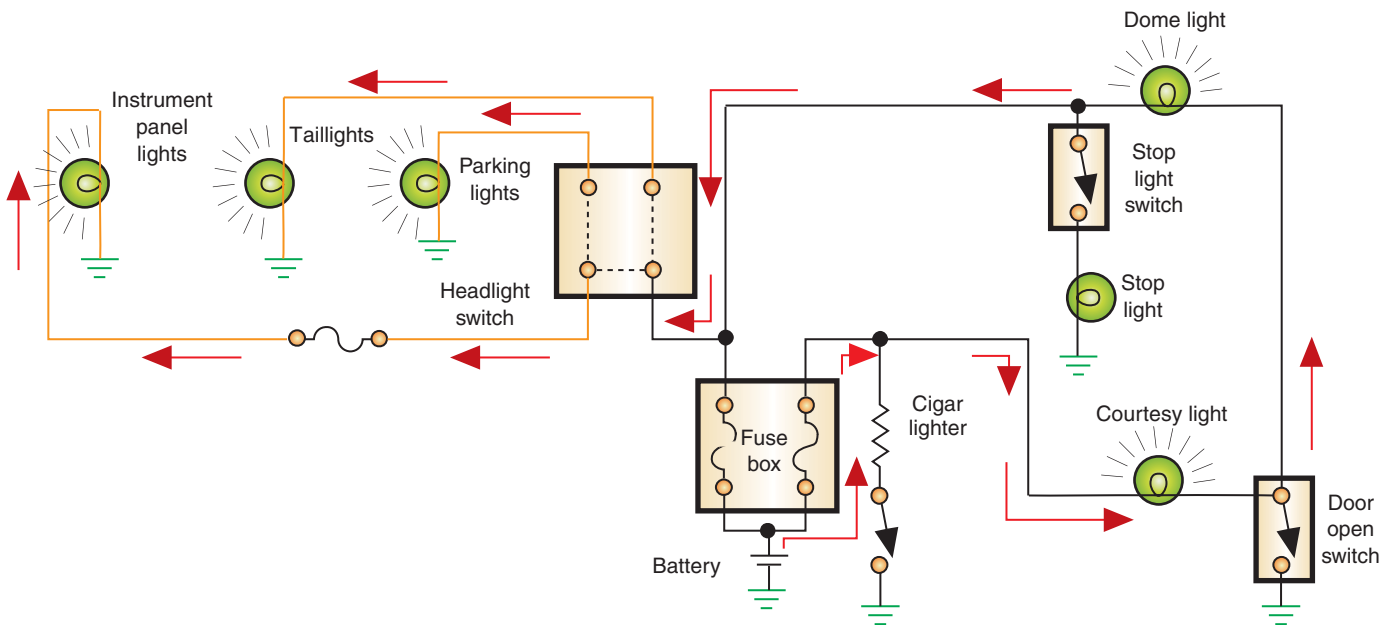
Examples of feedback and how it may cause undesired operation are illustrated in Figures 8-43 through 8-50. The illustration (Figure 8-43) shows a system that has the dome light, taillight, and brake light circuits on one fuse; the cigarette lighter circuit has its own fuse. The two fuses are located in the main fuse block and share a common bus bar on the power side.

If the dome light fuse blew and the headlight switch was in the PARK or HEADLIGHT position, the courtesy lights, dome light, taillight, parking lights, and instrument lights would all be very dimly lit (Figure 8-44). Current would flow through the cigarette lighter fuse to the



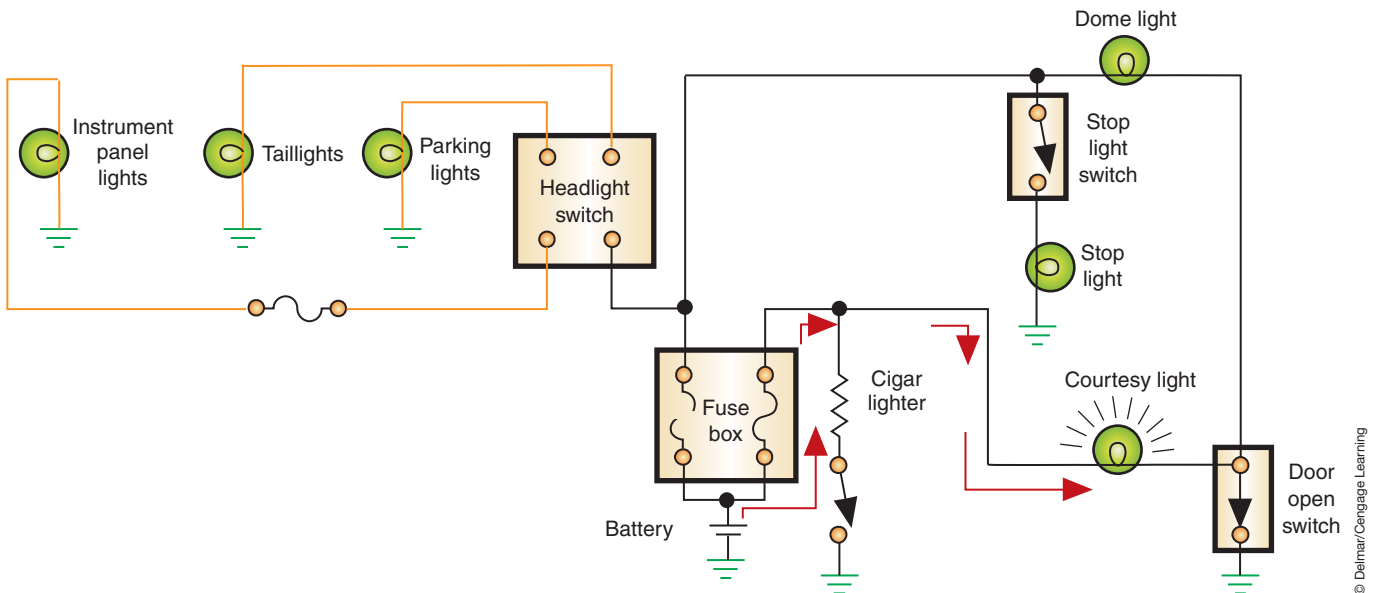
**FIGURE 8-43** A normally operating light circuit.





© Delmar/Cengage Learning

**FIGURE 8-44** An open (blown) dome light fuse can cause feedback into other circuits when the headlights are turned on.



© Delmar/Cengage Learning

**FIGURE 8-45** Circuit operation with a blown dome light fuse and the door switch closed.

courtesy light and on to the door light switch. Current will then continue through the dome light to the headlight switch. Because the headlight switch is now closed, the instrument panel lights are also in the circuit. The lights are dim because all the bulbs are now connected in series.

If the dome light fuse is blown and the headlight switch is in the OFF position, all lights will turn off. However, if the door is opened, the courtesy lights will come on but the dome light will not (Figure 8-45).

With the same blown fuse and the brake light switch closed, the dome light, courtesy light, and brake light will all illuminate dimly because the loads are in series (Figure 8-46).

In this example, if the dome light and courtesy lights come on dimly when the cigarette lighter is pushed in, the problem can be caused by a blown cigarette lighter fuse (Figure 8-47). With the cigarette lighter pushed in, a path to ground is completed. The lights and cigarette

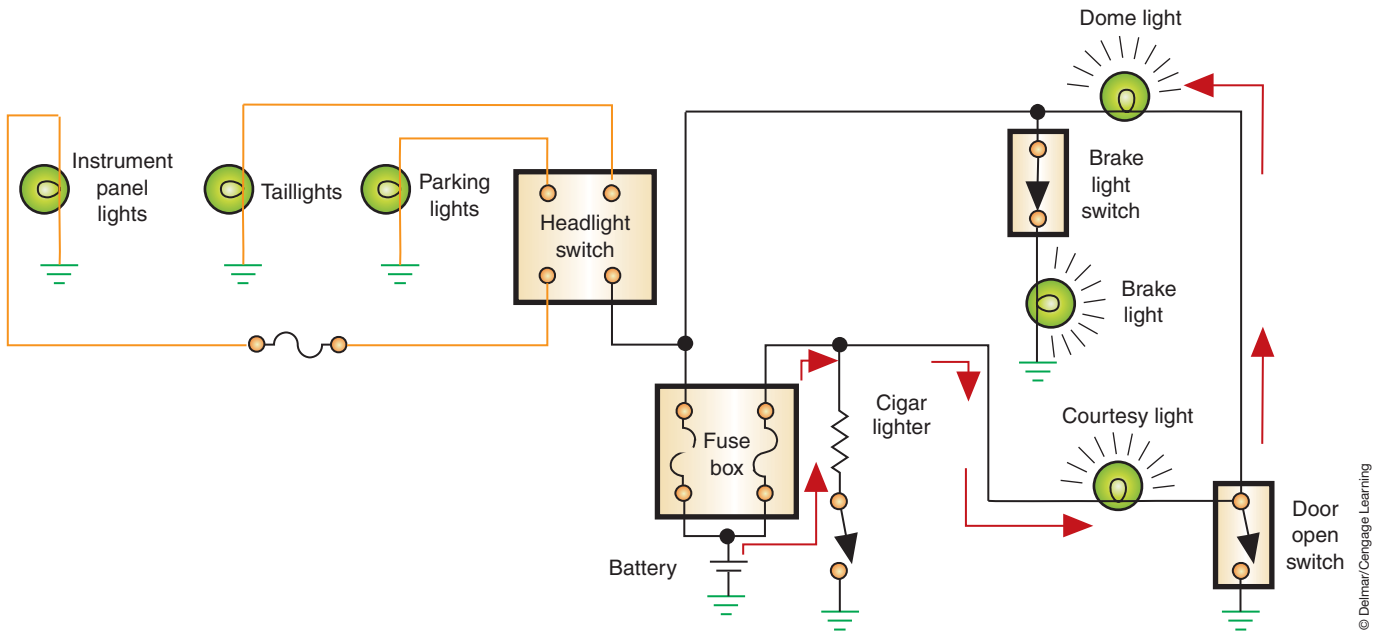


FIGURE 8-46 Feedback when brake light switch is closed.

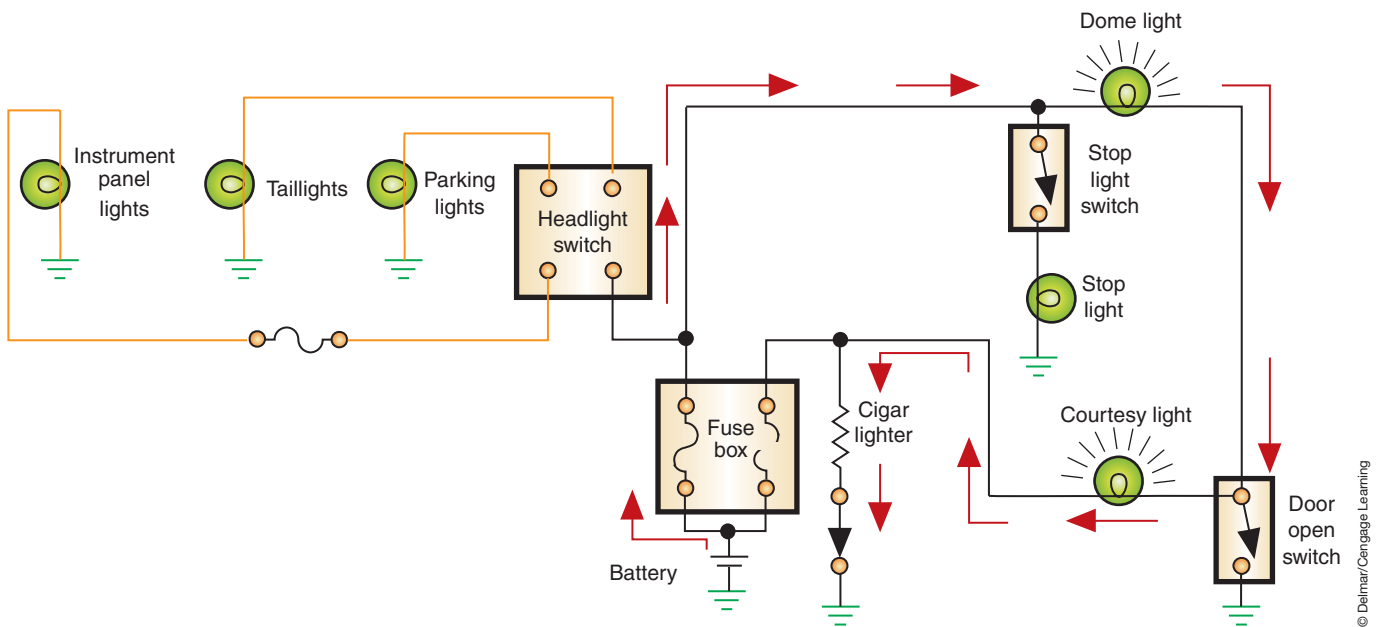
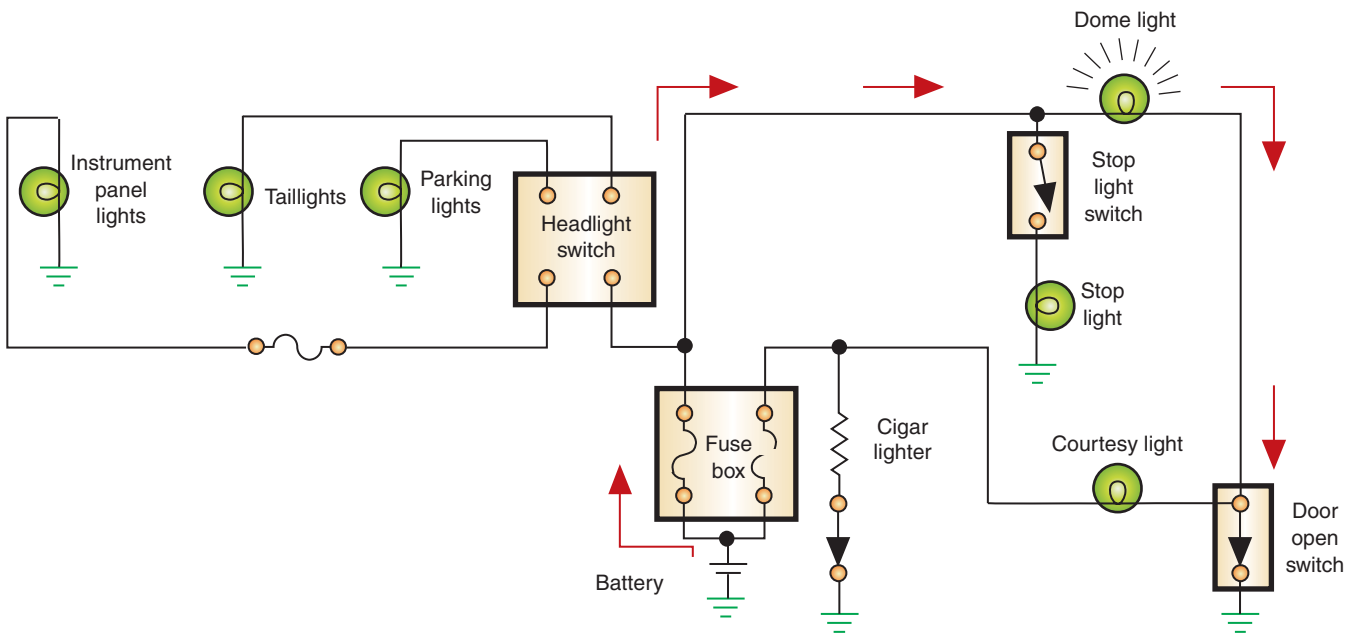


FIGURE 8-47 Feedback as a result of the cigar lighter fuse being blown.

lighter are now in series; thus the lights are dim and there is not enough current to heat and release the cigarette lighter. If the cigarette lighter was left in this position, the battery would eventually drain down.

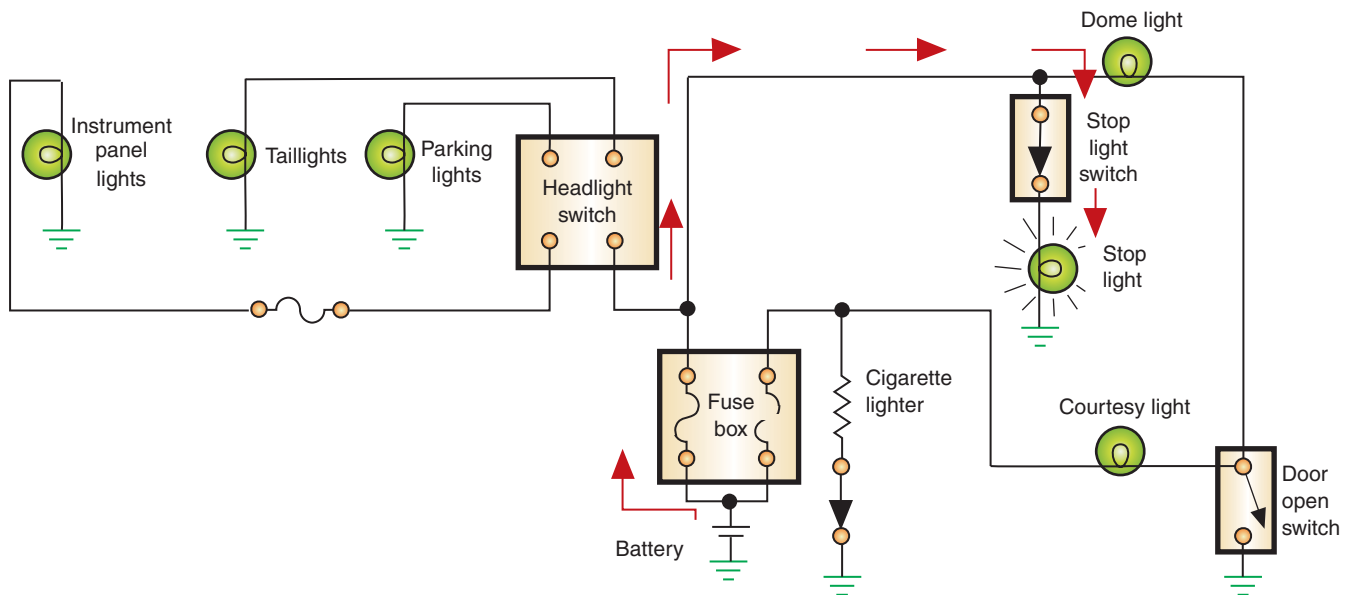
A blown cigarette lighter fuse will also cause the dome light to get brighter when the doors are open, and the courtesy lights will go out (Figure 8-48). Also, if the lighter is pushed in and the brake light switch is closed, the dome and courtesy lights will go out (Figure 8-49).

Feedback can also be the result of a conductive corrosion that is developed at a connection. If the corrosion allows for current flow from one conductor to an adjacent conductor in



**FIGURE 8-48** Opening the door will make the courtesy light go out and the dome light get brighter.

© Delmar/Cengage Learning



**FIGURE 8-49** Dome and courtesy lights go out when the brakes are applied.

© Delmar/Cengage Learning

the connection, the other circuit will also be activated. The illustration (Figure 8-50) shows how corrosion in a common connector can cause the dome light to illuminate when the wiper motor is turned on. Because the wiper motor has a greater resistance than the light bulb, more voltage will flow through the bulb than through the motor. The bulb will light brightly, but the motor will turn very slowly or not at all. The same effect will result if the courtesy light switch is turned on with the motor switch off.

**AUTHOR'S NOTE:** Dual-filament light bulb sockets are subject to corrosion that can cause feedback. Also, dual-filament bulbs can have a filament burn out and attach to the other filament and result in feedback. The most common indicator of this problem is parking lights that illuminate when the brake pedal is applied.

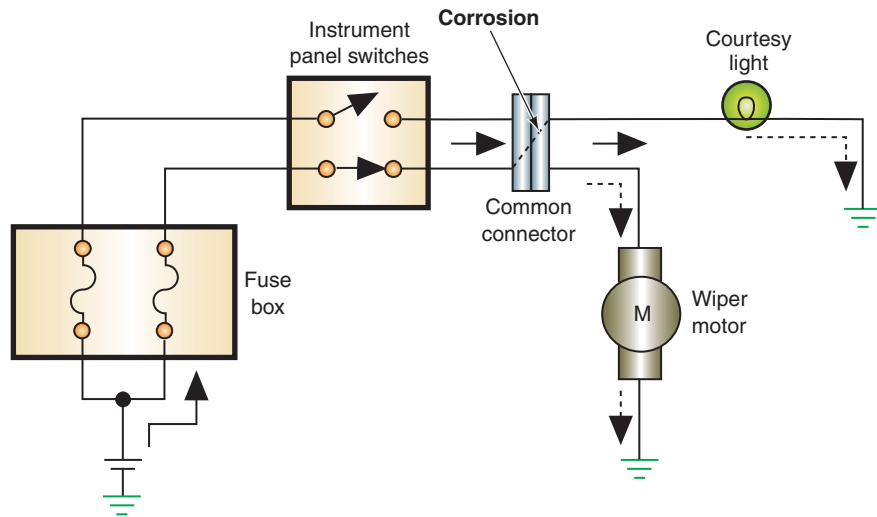


FIGURE 8-50 A corroded common connection can cause feedback.

© Delmar/Cengage Learning

## CASE STUDY

A customer says the cornering lights on the vehicle are working only part of the time. The technician turns on the turn signals and the cornering lights illuminate. She then shakes the vehicle and notices that the cornering lights stop working. The lights come on when the vehicle is shaken again.

The technician checks all of the connections at the battery and at the light sockets. All are good. The technician then shakes the vehicle until the cornering lights go out. Next, she uses a test light to check

for voltage at the light sockets. The test light does not come on. Tracing the circuit backward toward the turn signal switch, the technician discovers a voltage into the switch, but not out of it. Once the turn signal switch is removed from the steering column, the cause of the problem is easily found. The spring that maintains pressure on the contacts of the cornering light switch has been dislodged. The contacts intermittently have continuity until the vehicle goes over a bump in the road.

### TERMS TO KNOW

- Curb height
- Dimmer switch
- Feedback
- Multifunction switch

## ASE-STYLE REVIEW QUESTIONS

1. When the headlights are switched from low beam to high beam all headlights go out. All of the following can cause this EXCEPT:
  - A. Faulty dimmer switch.
  - B. Defective high-beam relay.
  - C. Defective ignition switch.
  - D. Open in high-beam circuit.
2. None of the turn signals operate. The LEAST likely cause of this is:
  - A. Burned-out bulbs.
  - B. Faulty turn signal switch.
  - C. Faulty turn signal flasher.
  - D. Open circuit from ignition feed to turn signal.
3. A customer states that the headlights are brighter than normal and that she has to replace the lamps regularly. *Technician A* says this can be caused by too-high generator output. *Technician B* says this can be caused by excessive voltage drop in the circuit. Who is correct?
 

A. A only	C. Both A and B
B. B only	D. Neither A nor B

4. A customer states that none of the external parking and headlights turn on.  
*Technician A* says the circuit from the battery to the switch may be faulty.  
*Technician B* says the headlight switch can be at fault.  
 Who is correct?  
 A. A only                    C. Both A and B  
 B. B only                    D. Neither A nor B
5. The taillight assembly is being discussed.  
*Technician A* says most taillight assemblies require the removal of the lens to replace the bulbs.  
*Technician B* says if all of the taillights do not operate, probe for voltage at a common connection.  
 Who is correct?  
 A. A only                    C. Both A and B  
 B. B only                    D. Neither A nor B
6. The turn signals of a vehicle operate in the left direction only.  
*Technician A* says the flasher is bad.  
*Technician B* says the fuse is blown.  
 Who is correct?  
 A. A only                    C. Both A and B  
 B. B only                    D. Neither A nor B
7. Diagnosis of the instrument panel lights is being discussed.  
*Technician A* says the power source for the instrument panel lights is provided through the headlight switch and rheostat.  
*Technician B* says the printed circuit board must be replaced.  
 Who is correct?  
 A. A only                    C. Both A and B  
 B. B only                    D. Neither A nor B
8. Composite headlight bulb replacement is being discussed.  
*Technician A* says care must be taken not to touch the envelope with your fingers.  
*Technician B* says not to energize the bulb unless it is installed into the socket.  
 Who is correct?  
 A. A only                    C. Both A and B  
 B. B only                    D. Neither A nor B
9. *Technician A* says the dimmer switch is connected in parallel to the headlight circuit.  
*Technician B* says concealed headlight doors cannot be manually opened.  
 Who is correct?  
 A. A only                    C. Both A and B  
 B. B only                    D. Neither A nor B
10. *Technician A* says if only one lamp in the circuit is not operating, the fastest check is to replace the bulb with a known good one.  
*Technician B* says to start the diagnostic tests at the easiest location to access.  
 Who is correct?  
 A. A only                    C. Both A and B  
 B. B only                    D. Neither A nor B

## ASE CHALLENGE QUESTIONS

1. The brake lights of a vehicle equipped with dual-function turn signal/brake lamps are inoperative. The turn signals are functioning properly. However, there is no power at the brake light terminals when the brake pedal is depressed.  
*Technician A* says that the brake light switch may be faulty.  
*Technician B* says that the turn signal switch may be faulty.  
 Who is correct?  
 A. A only                    C. Both A and B  
 B. B only                    D. Neither A nor B
2. The left turn signals of a vehicle are flashing very slowly; the right turn signals are operating correctly.  
*Technician A* says that this may be caused by excessive circuit resistance on the left turn signal circuit.  
*Technician B* says that this may be occurring because someone may have installed bulbs with higher-than-normal wattage ratings on the left side of the vehicle.  
 Who is correct?  
 A. A only                    C. Both A and B  
 B. B only                    D. Neither A nor B

3. The right back-up lamp on a vehicle is dim; the left back-up lamp is working correctly.

*Technician A* says that the back-up lamp switch may have excessive resistance.

*Technician B* says that the back-up lamp fuse may have corroded terminals.

Who is correct?

- A. A only                      C. Both A and B  
B. B only                      D. Neither A nor B
4. All of the following could cause premature failure of a composite bulb except:
- A. High-charging system voltage.  
B. Excessive bulb circuit ground resistance.  
C. Improper bulb handling.  
D. Cracked lamp housing.

5. The courtesy lamps of a vehicle equipped with insulated side door plunger switches are remaining on after all of the doors are closed.

*Technician A* says that one of the door plunger switches may be shorted to ground.

*Technician B* says that one of the door plunger switches may be remaining electrically “open.”

Who is correct?

- A. A only                      C. Both A and B  
B. B only                      D. Neither A nor B



Name \_\_\_\_\_ Date \_\_\_\_\_

## DIAGNOSING LIGHTING SYSTEMS

Upon completion of this job sheet, you should be able to diagnose the cause of a no-light operation fault and determine needed repairs.

### ASE Correlation

This job sheet is related to the ASE Electrical/Electronic System Certification Exam's content area: *Headlights, Parking Lights, Taillights, Dash Lights, and Courtesy Lights*; task: Diagnose no-light condition and determine necessary action.

### Tools and Materials

- Vehicle
- Wiring diagram for the vehicle
- DMM
- Test light

### Describe the vehicle being worked on:

Year \_\_\_\_\_ Make \_\_\_\_\_ Model \_\_\_\_\_  
 VIN \_\_\_\_\_ Engine type and size \_\_\_\_\_

### Procedure

Task Completed \_\_\_\_\_

1. Record the concern the customer would have with the lighting system.

---



---



---

2. Confirm the customer's concern by performing a check of the system and record your results.

---



---

3. Determine if there are any other symptoms that may be related to the customer's concern by testing the operation of other systems. Record your results.

---



---



---



---

---

Task Completed

4. Analyze the symptoms and reference the wiring diagram to determine the most likely location of the fault. Record the component(s) and its (their) location(s).

---

---

---

5. Locate a component from step 4 and return to the vehicle to test it. Describe the test procedure used and record the results.

6. Based on your diagnostic checks, was the cause of the problem located?

Yes  No

If yes, record your findings:

If no, continue to test other components identified in step 4.

7. If the fault is determined, make the repair and verify proper operation. Was the repair successful?  Yes  No

If no, continue testing the system.

Instructor's Response \_\_\_\_\_

---

---

Name \_\_\_\_\_ Date \_\_\_\_\_

## CHECKING A HEADLIGHT SWITCH

Upon completion of this job sheet, you should be able to check the operation of a headlight switch with an ohmmeter.

### ASE Correlation

This job sheet is related to the ASE Electrical/Electronic System Certification Exam's content area: *Headlights, Parking Lights, Taillights, Dash Lights, and Courtesy Lights*; task: Inspect, test, and repair or replace headlight dimmer switches, relays, control units, sensors, sockets, connectors, and wires of headlight circuits.

### Tools and Materials

- A vehicle
- A wiring diagram for the vehicle
- A DMM

### Describe the vehicle being worked on:

Year \_\_\_\_\_ Make \_\_\_\_\_ Model \_\_\_\_\_  
 VIN \_\_\_\_\_ Engine type and size \_\_\_\_\_

### Procedure

Task Completed \_\_\_\_\_

1. Put the headlight switch in all possible positions and observe which lights are controlled by each position. List each position and the controlled lights below.

---



---



---



---



---



---

2. Locate the headlight switch in the wiring diagram and print out or draw the switch with each possible connection and possible position. Label the lights controlled by each position of the switch. Highlight the path of each position from the power source to ground. Highlight different circuitry with different colors.

3. Remove the fuse to the headlights or disconnect the battery's negative cable. Remove the headlight switch according to the procedures outlined in the service information. Describe the procedure to your instructor before removing it.

**Instructor's OK to move to the next step.** \_\_\_\_\_

Task Completed

4. Identify the various terminals of the switch and list the different terminals that should have continuity in the various switch positions.

---

---

---

5. Connect the ohmmeter across these terminals, one switch position at a time, and record your readings below:

---

---

---

---

6. Based on the test, what are your conclusions about the switch?

---

---

---

---

7. Reinstall the switch and connect the negative battery cable or reinstall the fuse. Then check the operation of the headlights.
8. Instructor's verification then vehicle is properly reassembled and proper operation of lighting system.  
**Instructor's OK** \_\_\_\_\_.

Instructor's Response \_\_\_\_\_  
\_\_\_\_\_  
\_\_\_\_\_

Name \_\_\_\_\_ Date \_\_\_\_\_

## HEADLIGHT AIMING

Upon completion of this job sheet, you should be able to adjust the aim of headlights using portable headlight aiming equipment.

### ASE Correlation

This job sheet is related to the ASE Electrical/Electronic System Certification Exam's content area: *Headlights, Parking Lights, Taillights, Dash Lights, and Courtesy Lights*; task: Inspect, replace, and aim headlights/bulbs.

### Tools and Materials

- A vehicle with adjustable headlights
- Portable headlight aiming kit
- Hand tools

### Describe the vehicle being worked on:

Year \_\_\_\_\_ Make \_\_\_\_\_ Model \_\_\_\_\_  
 VIN \_\_\_\_\_ Engine type and size \_\_\_\_\_

### Procedure

Task Completed

1. Describe the type of headlights used on the vehicle.

\_\_\_\_\_  
 \_\_\_\_\_

2. Park the vehicle on a level floor.  
 Install the calibrated aiming units to the headlights. (Make sure the adapters fit the headlight aiming pads on the lens.)

3. Zero the horizontal adjustment dial. Are the split-image target lines visible in the view port? \_\_\_\_\_ If the lines cannot be seen, what should you do?

\_\_\_\_\_

4. Turn the headlight horizontal adjusting screw until the split-image target lines are aligned. Then repeat this for the other headlight. List any problems you may have had doing this.

\_\_\_\_\_  
 \_\_\_\_\_  
 \_\_\_\_\_

Task Completed

- 
- 
- 

5. Turn the vertical adjustment dial on the aiming unit to zero. Turn the vertical adjustment screw until the spirit level bubble is centered. Recheck your horizontal setting after adjusting the vertical.
6. List any problems you had making the vertical adjustment.

---

---

---

7. If the headlight assembly has four lamp assemblies, repeat steps 4 and 5 on the other two lamps. List below any problems you may have had doing this.

---

---

---

Instructor's Response \_\_\_\_\_

---

---

DIAGNOSTIC CHART 8-1	
PROBLEM AREA:	Headlights - Park/Taillights
SYMPTOMS:	Bright illumination, early bulb failure.
POSSIBLE CAUSES:	1. Alternator output too high. 2. Defective dimmer switch.

DIAGNOSTIC CHART 8-2	
PROBLEM AREA:	Headlights - Park/Taillights
SYMPTOMS:	Intermittent headlight or Park/Taillights operation, headlights flicker.
POSSIBLE CAUSES:	1. Defective circuit breaker. 2. Overload in circuit. 3. Improper connection. 4. Defective switch. 5. Poor ground. 6. Excessive resistance.

DIAGNOSTIC CHART 8-3	
PROBLEM AREA:	Headlights
SYMPTOMS:	Dim headlight illumination
POSSIBLE CAUSES:	1. Poor ground connection. 2. Corroded headlight socket. 3. Poor battery cable connections. 4. Low generator output. 5. Loose or broken generator drive belt.



<b>DIAGNOSTIC CHART 8-4</b>	
PROBLEM AREA:	Headlights - Park/Taillights
SYMPTOMS:	No or improper headlight or Park/Taillights operation.
POSSIBLE CAUSES:	<ol style="list-style-type: none"> <li>1. Burned-out headlights.</li> <li>2. Defective headlight switch.</li> <li>3. Open circuit.</li> <li>4. Defective circuit breaker.</li> <li>5. Overload in circuit.</li> <li>6. Improper or poor connection.</li> <li>7. Poor ground.</li> <li>8. Excessive resistance.</li> <li>9. Defective relay.</li> <li>10. Blown fuse.</li> <li>11. Faulty dimmer switch.</li> <li>12. Short in insulated circuit.</li> <li>13. Improper bulb application.</li> <li>14. Improper headlight aiming.</li> </ol>

<b>DIAGNOSTIC CHART 8-5</b>	
PROBLEM AREA:	Concealed headlight system
SYMPTOMS:	Headlight doors fail to operate properly.
POSSIBLE CAUSES:	<ol style="list-style-type: none"> <li>1. Loose or broken vacuum connections.</li> <li>2. Defective vacuum motors.</li> <li>3. Defective switch.</li> <li>4. Defective electrical door motors.</li> <li>5. Defective limit switch(es).</li> <li>6. Open circuit.</li> <li>7. Poor ground connection.</li> </ol>

<b>DIAGNOSTIC CHART 8-6</b>	
PROBLEM AREA:	Instrument cluster lighting
SYMPTOMS:	Intermittent brightness control of instrument cluster light circuits. Dash lights flicker.
POSSIBLE CAUSES:	<ol style="list-style-type: none"> <li>1. Improper connection.</li> <li>2. Defective headlight switch rheostat.</li> <li>3. Poor ground.</li> <li>4. Excessive resistance.</li> <li>5. Faulty printed circuit.</li> </ol>

<b>DIAGNOSTIC CHART 8-7</b>	
PROBLEM AREA:	Instrument cluster lighting
SYMPTOMS:	Low-level light intensity from panel illumination lights.
POSSIBLE CAUSES:	<ol style="list-style-type: none"> <li>1. Burned-out bulbs.</li> <li>2. Defective headlight switch rheostat.</li> <li>3. Improper bulb application.</li> <li>4. Improper connection.</li> <li>5. Poor ground.</li> <li>6. Excessive resistance.</li> <li>7. Defective or faulty printed circuit.</li> </ol>

<b>DIAGNOSTIC CHART 8-8</b>	
PROBLEM AREA:	Instrument cluster lighting
SYMPTOMS:	No bulb illumination.
POSSIBLE CAUSES:	<ol style="list-style-type: none"> <li>1. Blown circuit protection device.</li> <li>2. Burned-out bulbs.</li> <li>3. Defective headlight switch rheostat.</li> <li>4. Open circuit.</li> <li>5. Improper connection.</li> <li>6. Poor ground.</li> <li>7. Excessive resistance.</li> <li>8. Improper bulb application.</li> <li>9. Defective printed circuit.</li> </ol>

<b>DIAGNOSTIC CHART 8-9</b>	
PROBLEM AREA:	Instrument cluster lighting
SYMPTOMS:	No dash light brightness control.
POSSIBLE CAUSES:	<ol style="list-style-type: none"> <li>1. Defective headlight switch rheostat.</li> </ol>

<b>DIAGNOSTIC CHART 8-10</b>	
PROBLEM AREA:	Courtesy lights
SYMPTOMS:	Intermittent courtesy light operation.
POSSIBLE CAUSES:	<ol style="list-style-type: none"> <li>1. Improper connection.</li> <li>2. Defective headlight switch.</li> <li>3. Defective door jam switch.</li> <li>4. Defective or sticking door switch.</li> <li>5. Poor ground.</li> <li>6. Excessive resistance.</li> </ol>

<b>DIAGNOSTIC CHART 8-11</b>	
PROBLEM AREA:	Courtesy lights
SYMPTOMS:	Dimmer-than-normal courtesy lights. Battery condition good.
POSSIBLE CAUSES:	<ol style="list-style-type: none"> <li>1. Improper bulb application.</li> <li>2. Improper connection.</li> <li>3. Poor ground.</li> <li>4. Excessive resistance.</li> </ol>

<b>DIAGNOSTIC CHART 8-12</b>	
PROBLEM AREA:	Courtesy light operation
SYMPTOMS:	No courtesy light illumination.
POSSIBLE CAUSES:	<ol style="list-style-type: none"> <li>1. Blown circuit protection device.</li> <li>2. Burned-out bulbs.</li> <li>3. Defective headlight switch.</li> <li>4. Defective door switches.</li> <li>5. Open circuit.</li> <li>6. Improper connection.</li> <li>7. Poor ground.</li> <li>8. Excessive resistance.</li> <li>9. Improper bulb application.</li> </ol>

<b>DIAGNOSTIC CHART 8-13</b>	
PROBLEM AREA:	Courtesy lights.
SYMPTOMS:	Courtesy lights stay on all of the time.
POSSIBLE CAUSES:	<ol style="list-style-type: none"> <li>1. Defective door jam switch.</li> <li>2. Defective headlight switch.</li> <li>3. Shorted circuit.</li> </ol>

<b>DIAGNOSTIC CHART 8-14</b>	
PROBLEM AREA:	Stop (brake) lamp operation
SYMPTOMS:	Intermittent stop lamp operation.
POSSIBLE CAUSES:	<ol style="list-style-type: none"> <li>1. Misadjusted brake light switch.</li> <li>2. Poor ground connection.</li> <li>3. Excessive resistance.</li> <li>4. Faulty sockets.</li> <li>5. Poor connections.</li> <li>6. Faulty turn signal switch contacts.</li> <li>7. Defective brake light switch.</li> </ol>

<b>DIAGNOSTIC CHART 8-15</b>	
PROBLEM AREA:	Stop (brake) lamp operation
SYMPTOMS:	Dimmer-than-normal stop lights.
POSSIBLE CAUSES:	<ol style="list-style-type: none"> <li>1. Excessive circuit resistance.</li> <li>2. Poor ground connection.</li> <li>3. Improper bulb application.</li> <li>4. Improper connections.</li> <li>5. Faulty turn signal switch contacts.</li> <li>6. Improper bulb application.</li> </ol>

<b>DIAGNOSTIC CHART 8-16</b>	
PROBLEM AREA:	Stop (brake) lamp operation
SYMPTOMS:	No stop lamps illuminate. Stop lights fail to illuminate when the brakes are applied.
POSSIBLE CAUSES:	<ol style="list-style-type: none"> <li>1. Faulty brake light switch.</li> <li>2. Open in the circuit.</li> <li>3. Improper bulb application.</li> <li>4. Faulty turn signal switch.</li> <li>5. Improper common ground connection.</li> <li>6. Burned-out light bulbs.</li> </ol>

<b>DIAGNOSTIC CHART 8-17</b>	
PROBLEM AREA:	Turn signal operation.
SYMPTOMS:	Turn signals do not operate in either direction.
POSSIBLE CAUSES:	<ol style="list-style-type: none"> <li>1. Blown fuse.</li> <li>2. Defective or worn flasher unit.</li> <li>3. Defective or faulty turn signal switch.</li> <li>4. Open circuit.</li> </ol>

<b>DIAGNOSTIC CHART 8-18</b>	
PROBLEM AREA:	Turn signals
SYMPTOMS:	Turn signal lamp does not illuminate.
	Turn signal indicator illuminates but does not flash.
POSSIBLE CAUSES:	<ol style="list-style-type: none"> <li>1. Improper bulb.</li> <li>2. Burned-out bulb.</li> <li>3. Open circuit.</li> <li>4. Failed flasher unit.</li> </ol>

<b>DIAGNOSTIC CHART 8-19</b>	
PROBLEM AREA:	Hazard light operation
SYMPTOMS:	Hazard lights fail to operate when activated.
POSSIBLE CAUSES:	<ol style="list-style-type: none"> <li>1. Blown fuse.</li> <li>2. Defective or worn flasher unit.</li> <li>3. Defective or faulty hazard light switch.</li> <li>4. Open circuit.</li> <li>5. Defective turn signal switch.</li> </ol>

<b>DIAGNOSTIC CHART 8-20</b>	
PROBLEM AREA:	Back-up light operation.
SYMPTOMS:	Back-up lights fail to operate some of the time.
POSSIBLE CAUSES:	<ol style="list-style-type: none"> <li>1. Misadjusted back-up light switch.</li> <li>2. Poor ground connection.</li> <li>3. Excessive resistance.</li> <li>4. Faulty sockets.</li> <li>5. Poor connections.</li> </ol>

<b>DIAGNOSTIC CHART 8-21</b>	
PROBLEM AREA:	Back-up light operation
SYMPTOMS:	Dimmer-than-normal back-up lights
POSSIBLE CAUSES:	<ol style="list-style-type: none"> <li>1. Excessive circuit resistance.</li> <li>2. Poor ground connection.</li> <li>3. Improper bulb application.</li> <li>4. Improper connections.</li> <li>5. Faulty back-up switch contacts.</li> </ol>

<b>DIAGNOSTIC CHART 8-22</b>	
PROBLEM AREA:	Back-up light operation
SYMPTOMS:	Back-up lights fail to illuminate when the transmission is in reverse.
POSSIBLE CAUSES:	<ol style="list-style-type: none"> <li>1. Faulty back-up light switch.</li> <li>2. Misadjusted back-up light switch.</li> <li>3. Blown fuse.</li> <li>4. Open in the circuit.</li> <li>5. Improper bulb application.</li> <li>6. Improper common ground connection.</li> <li>7. Burned-out light bulbs.</li> </ol>

<b>DIAGNOSTIC CHART 8-23</b>	
PROBLEM AREA:	Back-up light does not operate
SYMPTOMS:	One back-up light fails to illuminate when the transmission is in reverse.
POSSIBLE CAUSES:	<ol style="list-style-type: none"> <li>1. Burned-out lamp.</li> <li>2. Loose connection.</li> <li>3. Open circuit to lamp.</li> </ol>

## BODY COMPUTER SYSTEM DIAGNOSIS



### BASIC TOOLS

Basic mechanic's tool set

Service information

### UPON COMPLETION AND REVIEW OF THIS CHAPTER, YOU SHOULD BE ABLE TO:

- Describe the service precautions associated with servicing the BCM.
- Diagnose computer voltage supply and ground circuits.
- Distinguish between hard and intermittent codes.
- Perform flash code retrieval on various vehicles.
- Erase fault codes.
- Perform a complete visual inspection of the problem system.
- Enter BCM diagnostics by use of a scan tool.
- Enter BCM diagnostics through the ECC panel.
- Perform basic actuator tests.
- Perform basic sensor tests.
- Replace computer PROM chips properly.
- Properly flash the BCM.

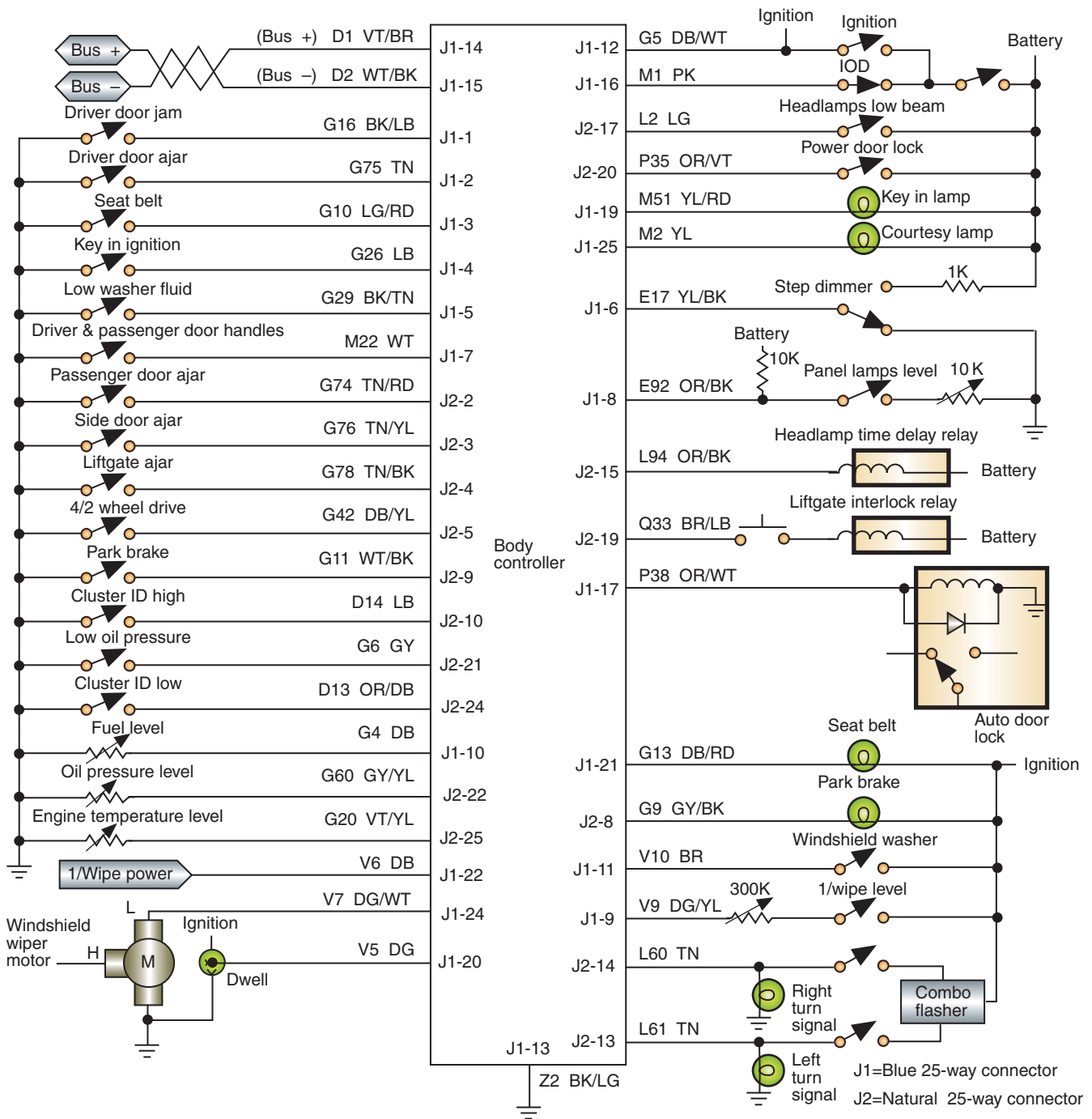
### INTRODUCTION

Because the body control module (BCM) controls many of the functions of the vehicle's electrical systems, it is important for today's technician to be able to properly diagnose problems with this system. The use of body computers has expanded to include the functions of climate control, lighting circuits, cruise control, antilock braking, electronic suspension systems, electronic shift transmissions, and alternator regulation. In some systems, the direction light, the rear window defogger, the illuminated entry, and the intermittent wiper systems are included in the body controller function (Figure 9-1).

**AUTHOR'S NOTE:** Many manufacturers are incorporating the functions of the typical BCM into other modules. For example, on many newer Chrysler vehicles the cabin compartment node (CCN) now performs the functions that were once the responsibility of the BCM. These vehicles no longer have a separate BCM. The term "BCM" will be used throughout this test to reference the stand-alone module and the functions that may be contained within any other module.

As discussed in the Classroom Manual, a computer processes the physical conditions that represent information (data). The operation of the computer is divided into four basic functions:

1. *Input:* A voltage signal that is sent from an input device. This device can be a sensor or a button activated by the driver or technician.
2. *Processing:* The computer uses the input information and compares it to programmed instructions. The logic circuits process the input signals into output demands.



**FIGURE 9-1** The body controller controls many of the vehicle's electrical systems.

3. *Storage:* The program instructions are stored into an electronic memory. Some of the input signals are also stored for later processing.
4. *Output:* After the computer has processed the sensor input and checked its programmed instructions, it will put out control commands to various output devices. These output devices may be the instrument panel display or a system actuator. The output of one computer can also be used as an input to another computer.

Understanding these four computer functions will help you organize the troubleshooting process. When a system is tested, you are attempting to isolate a problem with one of these functions.



In the process of controlling the various electrical systems, the BCM continuously monitors operating conditions for possible system malfunctions. The computer compares system conditions against programmed parameters. If the conditions fall outside of these limits, the computer detects a malfunction. A **diagnostic and trouble code (DTC)** is set to indicate the portion of the system at fault. The technician can access this code for aid in troubleshooting.

If a malfunction results in improper system operation, the computer may minimize the effects by using **fail soft** action. This provides limited system operation by substituting a fixed input value if a sensor circuit should fail. For example, if the automatic temperature control system has a malfunction from the ambient temperature sensor, instead of shutting down the whole system, the computer will provide a fixed value as its own input. This fixed value can be programmed into the computer's memory, or it can be the last received signal from the sensor prior to failure. This allows the system to operate on a limited basis instead of shutting down completely. Some other faults may result in the automatic temperature control system switching to high fan speed, full heat, or defrost mode.

There are several things you need to know before you learn how to access the computer's memory to gain information concerning system operation. You need to become familiar with what you're looking at and you must follow proper precautions when servicing these systems.

## ELECTRONIC SERVICE PRECAUTIONS

The technician must take some precautions before servicing the body computer or any of its controlled systems. The BCM is designed to withstand normal current draws associated with normal operation. However, overloading any of the system circuits will result in damage to the BCM. Follow these service precautions to prevent BCM and circuit damage:

1. Do not ground or apply voltage to any controlled circuits unless the service information instructs you to do so.
2. Use only a high **impedance** multimeter (10 megaohm or greater) to test the circuits. Impedance is the combined opposition to current created by the resistance, capacitance, and inductance of the meter. Never use a test light unless specifically instructed to do so in the service information.
3. Make sure the ignition switch is turned off before making or breaking electrical connections to the BCM.
4. Unless instructed otherwise in the service information, turn off the ignition switch before making or breaking any electrical connections to sensors or actuators.
5. Turn the ignition switch off whenever disconnecting or connecting the battery terminals. Also turn it off when pulling and replacing the fuse.
6. Do not connect any other electrical accessories to the insulated or ground circuits of the computer-controlled systems.
7. Use only manufacturer's specific test and replacement procedures for the year and model of vehicle being serviced.
8. Wear an **electrostatic discharge (ESD) strap** to ground your body to prevent static discharges that may damage electronic components.

By following these precautions, plus those listed in the service information, you can avoid having to replace expensive components.

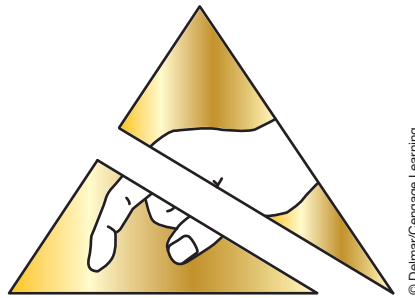
## Electrostatic Discharge

Some manufacturers mark certain components and circuits with a code or symbol to warn technicians that the units are sensitive to electrostatic discharge (Figure 9-2). Static electricity can destroy or render a component useless.

When handling any electronic part, especially those that are static sensitive, follow the guidelines below to reduce the possibility of electrostatic buildup on your body and

**Fail soft** action is commonly known as the computer's "limp-in mode."

Static electricity can be 25,000 volts or higher.



© Delmar/Cengage Learning

**FIGURE 9-2** One type of Electrostatic Discharge (ESD) symbol used to warn the technician that the component or circuit is sensitive to static.

the inadvertent discharge to the electronic part. If you are not sure if a part is sensitive to static, treat it as if it is.

1. Always touch a known good ground before handling the part. This should be repeated while handling the part and more frequently after sliding across a seat, sitting down from a standing position, or walking a distance.
2. Avoid touching the electrical terminals of the part unless you are instructed to do so in the written service procedures. It is good practice to keep your fingers off all electrical terminals as the oil from your skin can cause corrosion.
3. When you are using a voltmeter, always connect the negative meter lead first.
4. Do not remove a part from its protective package until it is time to install the part.
5. Before removing the part from its package, ground yourself and the package to a known good ground on the vehicle.
6. When replacing a PROM, ground your body by putting on an ESD strap and connect the other end to a good ground.

## Electromagnetic Interference

Electromagnetic interference (EMI) or radio frequency interference (RFI) can cause problems with the vehicle's on board computers. Unfortunately, an automobile's spark plug wires, ignition coil, and generator all possess the ability to generate these radio waves. Under the right conditions, RFI can trigger sensors or actuators. The result may be an intermittent drivability problem with system operation.

To minimize the effects of RFI, make sure your visual inspection is thorough. Also check to make sure that sensor wires running to the computer are routed away from potential RFI sources. Rerouting a wire by no more than an inch or two (25 to 50 mm) may keep RFI from falsely triggering or interfering with computer operation. RFI can be present on a voltage signal or on a ground.

Most manufacturers shield their BCM from EMI and RFI. However, this shielding will only work if the BCM is properly grounded. Always confirm a good ground before condemning the BCM. Some BCMs may have up to five grounds.

In addition, confirm that all grounding straps are properly connected. A loose or missing grounding strap can cause erratic voltages to be seen by the computer and cause multiple issues.

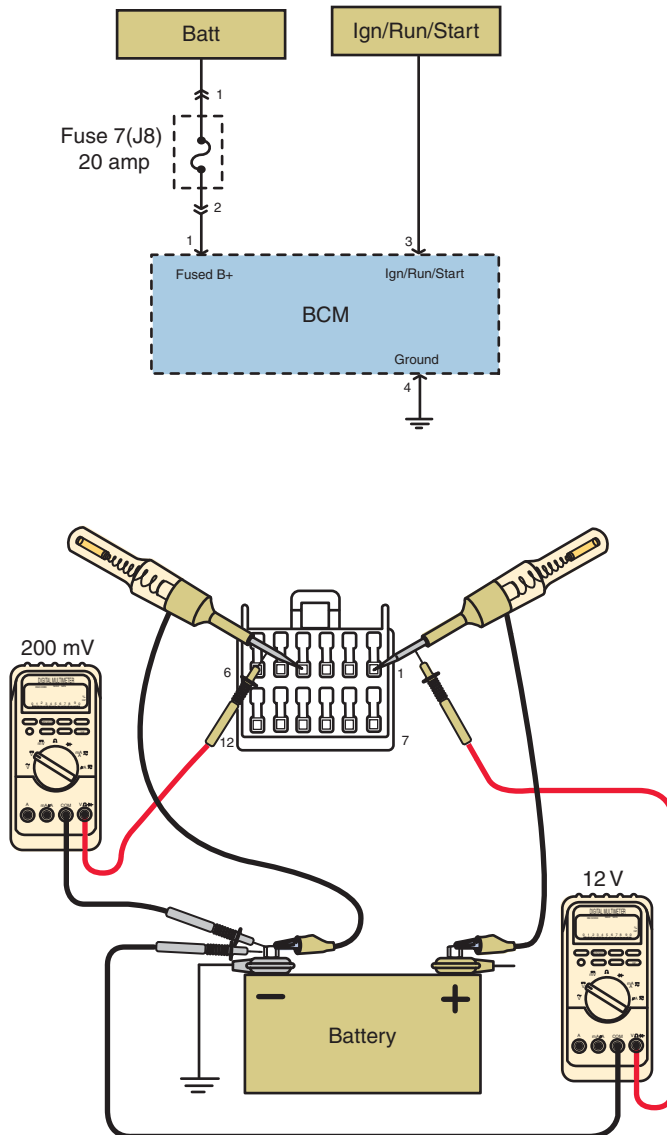
## DIAGNOSIS OF COMPUTER VOLTAGE SUPPLY AND GROUND CIRCUITS

Like any other electrical or electronic component, a computer cannot operate properly unless it has satisfactory voltage supply at the required terminals and proper ground connections. A computer wiring diagram for the vehicle being tested must be available for these tests. First, measure the voltage across the battery terminals as a reference. Now, backprobe the battery feed terminal to the computer and connect the DVOM leads to this terminal and to ground.

The voltage at the battery feed terminal should be 0.5 volt of battery voltage with the ignition switch off. If the proper voltage is not present at this terminal, check the computer fuse and related circuit. Turn the ignition switch to the RUN position and check applied voltage to *all* battery and ignition feed terminals of the PCM. The voltage measured at these terminals should be within 0.5 volt of battery voltage. If the specified voltage is not available, test the voltage supply wires to these terminals. These terminals may be connected through fuses, fuse links, or relays. Always refer to the vehicle manufacturer's wiring diagram for the vehicle being tested.

Computer ground wires usually extend from the computer to a ground connection on the engine or battery. Often there is more than one ground wire. In addition, the fasteners used to attach the computer to the vehicle chassis may be used as a ground. With the ignition switch in the RUN position, perform a voltage drop test across the ground wires. Compare your results with specifications. A good circuit should not drop more than 0.2 volt on the ground circuit.

If the manufacturer does not allow for backprobing of the connector, then use a breakout box or carefully forward probe the connector. In this case the voltage test is an open circuit. To achieve accurate results the circuit must be loaded. Use a high impedance test light that draws about 250mA to load the circuit and then measure the voltage at the test lamp (Figure 9-3).



**FIGURE 9-3** Using a test light to load the circuit when the connector is unplugged.



### SPECIAL TOOLS

DVOM  
Lab scope



### SERVICE TIP:

Never replace a computer unless the ground wires and voltage supply wires are proven to be in satisfactory condition.



### SERVICE TIP:

When diagnosing computer problems, it is usually helpful to ask the customer about service work that has been performed lately on the vehicle. If service work has been performed, it is possible that a computed ground wire may be loose or disconnected.

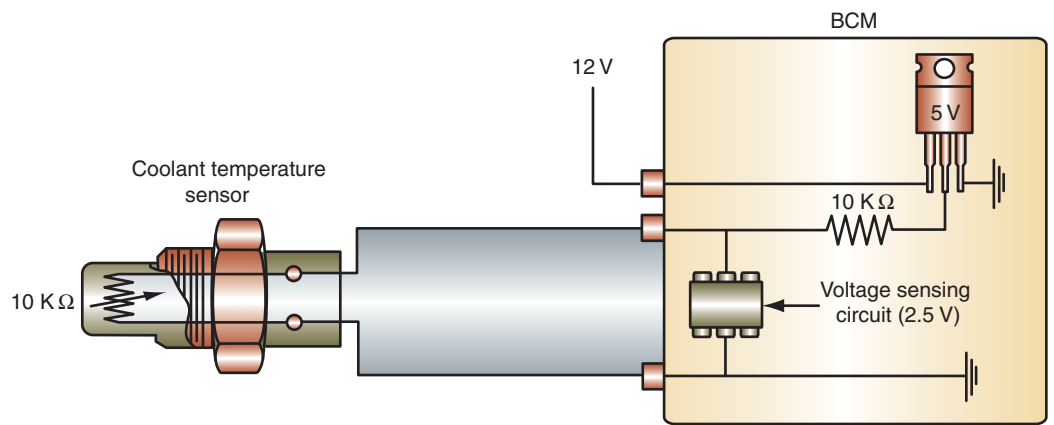
© Delmar/Cengage Learning

When testing the battery and ignition feed circuits, the voltmeter should read within 500 mV of battery voltage. When reading the voltage of the ground circuit, the voltmeter should read less than 200 mV.

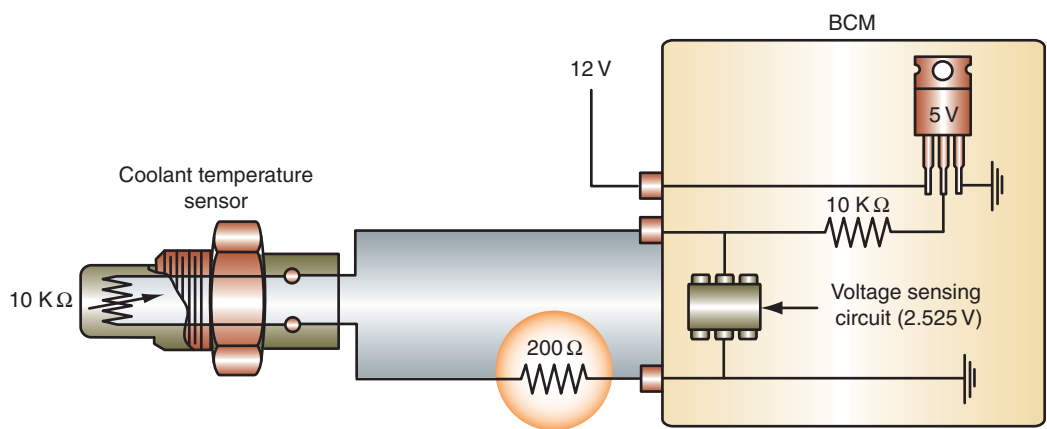
It is imperative to test all power and ground circuits. There may be multiple direct battery feeds and multiple grounds. Although these may be referred to as “redundant” powers and grounds, they do not actually become substitute circuits in the event that the other drops off. For example, a module may have two direct power feeds and two ground circuits. If one of the power feeds should open, the other does not make up for it. In this case, it is possible that each power feed supplies a microprocessor, so if one is lost then one of the microprocessors fails to power up. The same may be true for the ground circuits. In fact, if a ground circuit is open, electrons will attempt to find alternate paths to grounds and the resulting feedback through the computer can result in very strange system operation.

## Sensor Return Circuit

Many manufacturers use a single sensor return circuit for all of the BCM sensors. This makes a good ground critical since a sensor return circuit that has high resistance will cause *all* of the sensors to indicate an erroneous voltage reading to the BCM. Consider a temperature-sensing circuit as an example (Figure 9-4). (A) indicates the normal voltage



(A) NORMAL SENSOR RETURN CIRCUIT



(B) RESISTANCE IN SENSOR RETURN CIRCUIT

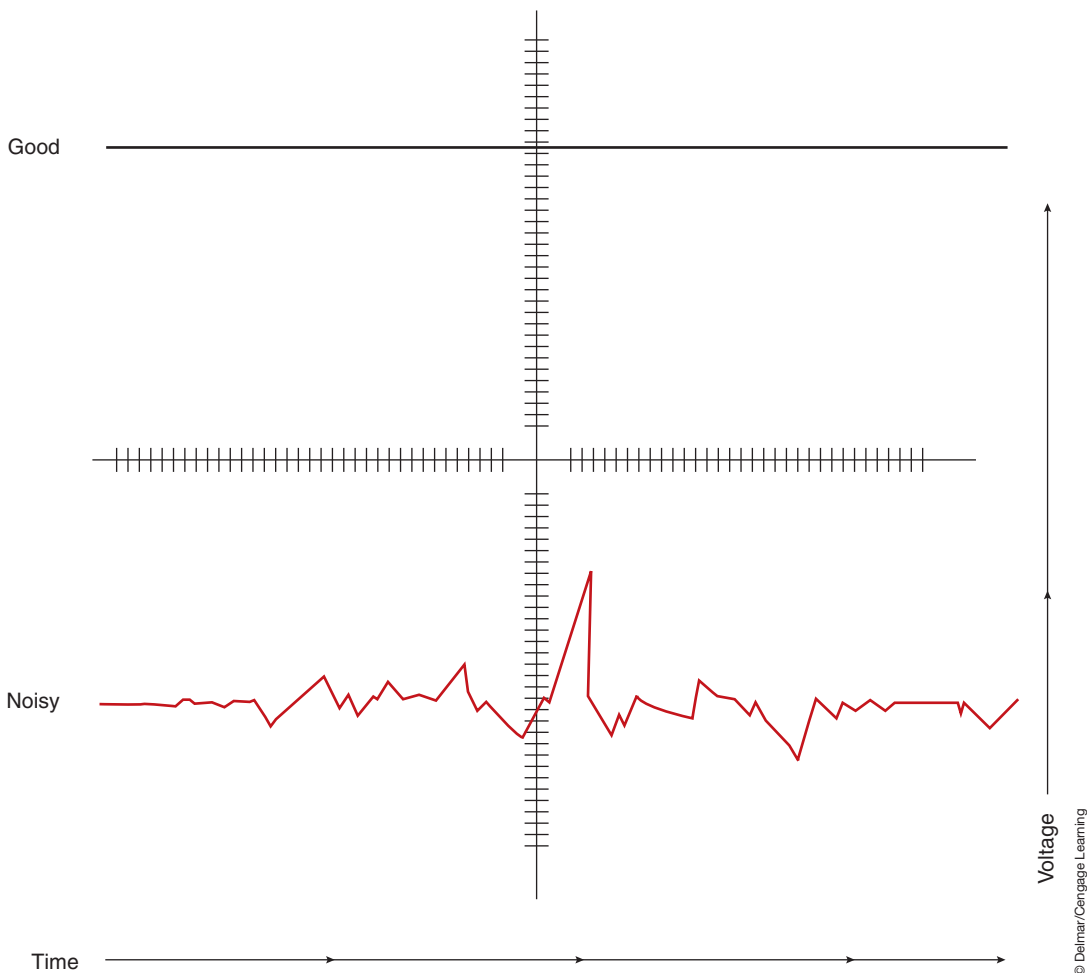
**FIGURE 9-4** The effect of resistance on the sensor return circuit. (A) Normal sensor voltage. (B) Voltage reading with NTC thermistor at the same resistance, but sensor return circuit has additional resistance.

sensed by the BCM with the NTC thermistor at 10 K ohms. (B) indicates the voltage sensed by the BCM with the NTC thermistor still at 10 K ohms but with an additional 200 ohms of resistance in the sensor's return circuit. The voltage is now off by 25 millivolts. Since the 200 ohms of resistance is also affecting all of the other sensors that share this return circuit, they are all off by 25 millivolts also. This may not seem like enough voltage to cause any problems, but remember that most systems are very sensitive to small voltage changes.

In addition to causing some system operation problems, this type of fault may not set a fault code. The voltage values are within the normal operating parameters of the sensor, so continuity faults will not set. Also, since all sensors are off by the same amount, rationality faults are not detected. System operation problems may occur as a result of the computer making bad decisions based on erroneous information.

Poor grounds can also allow electromagnetic interference (EMI) or noise to be present on the reference voltage signal. This noise causes minute changes in the voltage going to the sensor; therefore, the output signal from the sensor will also have these voltage changes. The computer will try to respond to these changes, which can cause a system operation problem. The best way to check for noise is to use a lab scope.

Connect the lab scope between the 5-volt reference signal to the sensor and ground. The trace on the scope should be flat (Figure 9-5). If noise is present, move the scope's negative probe to a known good ground. If the noise disappears, the sensor's ground circuit is



**FIGURE 9-5** (Top) Voltage signal trace of a good circuit. (Bottom) Trace of a circuit with excess noise.



### SERVICE TIP:

In light of the total number of vehicles being produced that use computer control systems, very few customer complaints are actually the fault of the computer. The computer should be replaced only if *all* other possible causes have been checked and confirmed as operating properly. Always check the condition of the battery feed and ground circuits of the computer before condemning the computer.

faulty or has resistance. If the noise is still present, the voltage feed circuit is faulty or there is EMI in the circuit from another source, such as the AC generator. Find and repair the cause of the noise.

Circuit noise may be present in either the positive side or the negative side of a circuit. It may also be evident by a popping noise from the radio. However, noise can cause a variety of problems in any electrical circuit. The most common sources of noise are electric motors, relays, solenoids, AC generators, ignition systems, switches, and A/C compressor clutches. Typically, noise is the result of an electrical device being turned on and off. Sometimes the source of the noise is a defective suppression device. Some of the commonly used noise suppression devices are resistor-type secondary cables and spark plugs, shielded cables, capacitors, diodes, and resistors. If the source of the noise is not a poor ground or a defective component, check the suppression devices.

Resistors that are used for noise suppression do not eliminate the spikes, but they do limit their intensity. When testing a circuit that uses a resistor to limit noise, if the lab scope trace indicates large voltage spikes, the resistor may be bad. Clamping diodes are used to suppress noise and induced voltages in circuits such as A/C compressor clutches and relays. If the diode is bad, a negative spike will result (Figure 9-6). Capacitors or chokes are used to control noise from motors and generators (Figure 9-7). To avoid much frustration during diagnosis of a computer system (especially the inputs), check the integrity of the ground as one of the first steps.

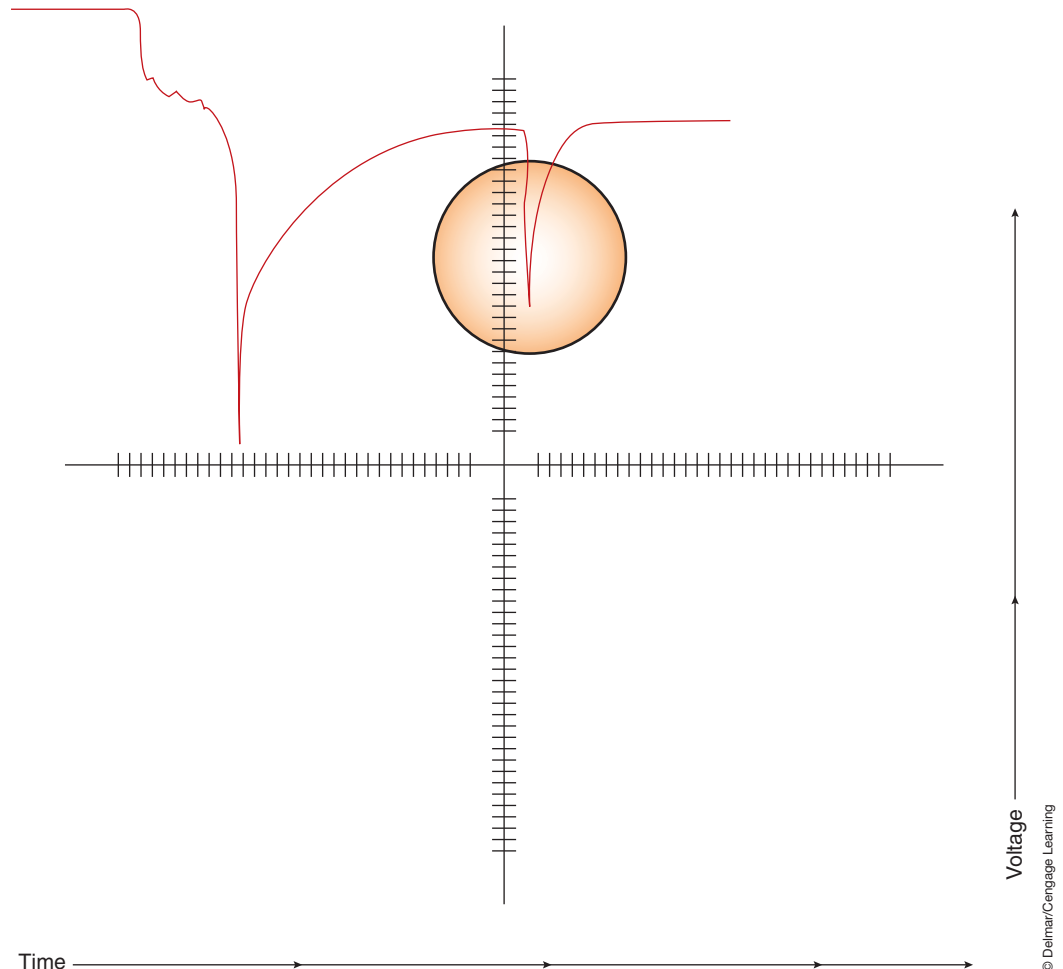
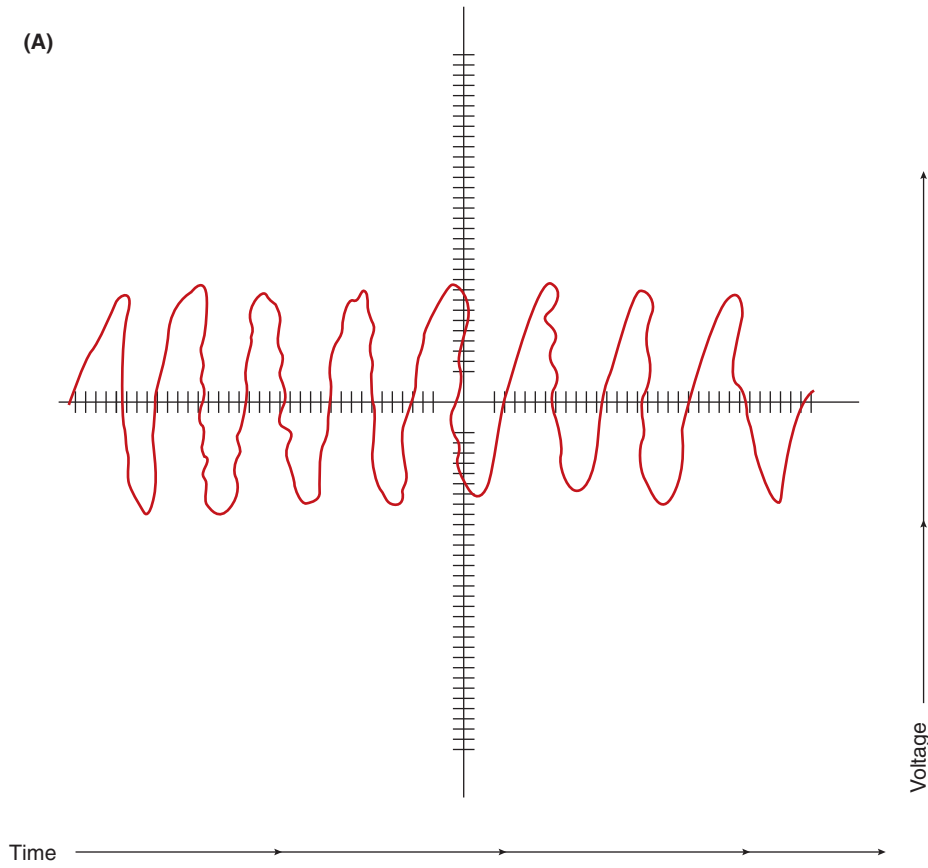


FIGURE 9-6 A voltage trace of an A/C circuit with a bad diode.

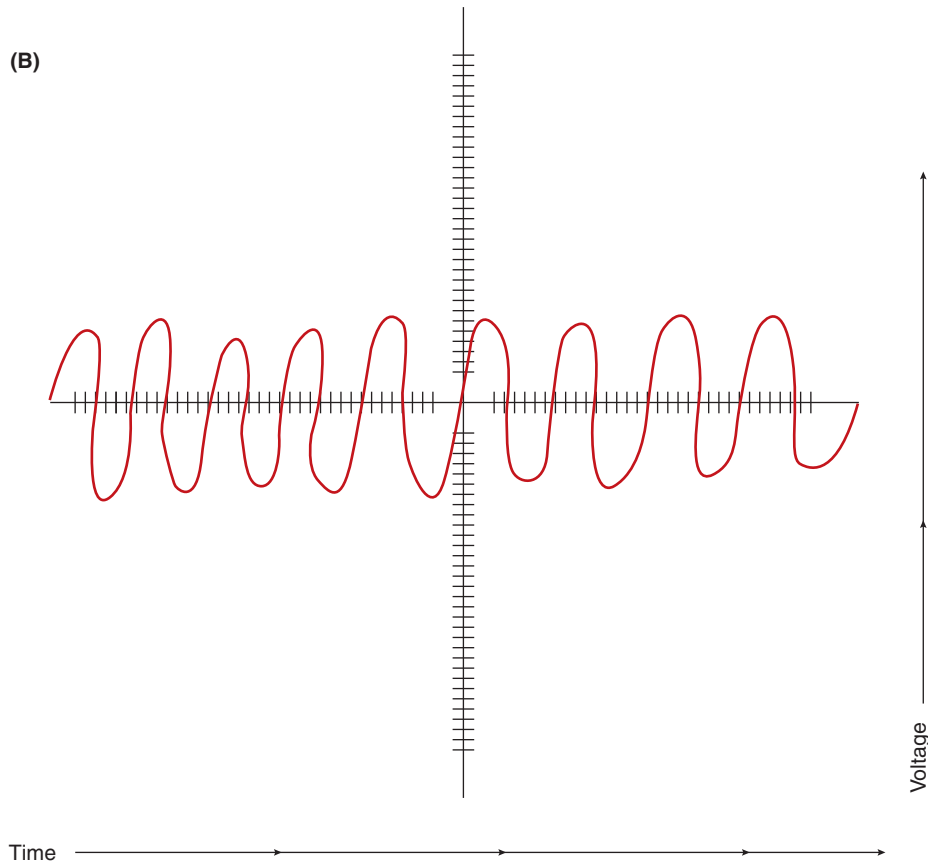
© Delmar/Cengage Learning



(A)



(B)



**FIGURE 9-7 (A) Voltage trace of motor without a chock. (B) Voltage trace of a motor with a chock.**

© Delmar/Cengage Learning



FIGURE 9-8 Example of a body function fault code.

## DIAGNOSTIC TROUBLE CODES

Once the computer performs a diagnostic test, or during the operation of the system, the microprocessor software determines whether the system and its circuits performed properly. If the system or circuit failed a diagnostic trouble code (DTC) is set.

Beginning in the 1996 model year, SAE published J2012 to describe industry-wide standards for a uniform DTC format. The trouble codes contain four characters, usually consisting of one letter and three numbers (Figure 9-8). The letter identifies the function of the device that has generated the fault code:

- P = Powertrain
- C = Chassis
- B = Body
- U = Network or DLC

The characters that follow identify the fault. These characters are usually numbers, but may also contain letters. Figure 9-8 is an example of a fault code set when the computer detected that the ignition switch input voltage above a calibrated value. Using this code, the technician would then follow a diagnostic routine in the service information to locate the cause.

Most BCMs are capable of displaying the stored faults in memory. Diagnostic trouble codes can be displayed by the scan tool and, in early systems, by a method referred to as **flash codes**. Flash codes are DTCs displayed by flashing a lamp or LED. The method used to retrieve the codes varies greatly, and the technician must refer to the correct service information for the procedure. Depending on system design, the computer may store codes for long periods of time; some lose the code when the ignition switch is turned off. Systems that do not retain the code when the ignition is turned off require that the technician test drive the vehicle and attempt to duplicate the fault. Once the fault is detected by the computer, the code must be retrieved before the ignition switch is turned off again.

The trouble code does not necessarily indicate the faulty component; it only indicates that circuit of the system that is not operating properly. For example, the code displayed may be F11, indicating an A/C high-side temperature sensor problem. This does not mean the sensor is bad; the fault is in that circuit, which includes the wiring, connections, sensor, and BCM. To locate the problem, follow the diagnostic procedure in the service information for the code received.

## Differences between Hard and Intermittent Codes

Some BCMs will store trouble codes in their memory until they are erased by the technician or until a set amount of engine starts have passed. Some computers will display two sets of fault codes. Usually, the first set of codes displayed represents all codes stored in memory, including both hard and intermittent codes. The second set of codes displayed are only **hard codes**. Hard codes are failures that were detected the last time the BCM tested the circuit. The codes displayed in the first set but not in the second set are **intermittent codes**. Intermittent codes are those that have occurred in the past but were not present during the last BCM test of the circuit.

Diagnostic trouble codes are also called “fault codes.”

Most diagnostic charts cannot be used to locate causes of intermittent codes. This is because the testing at various points of the chart depends on the fault being present to locate the problem. If the fault is not present, the technician may be erroneously instructed to replace the BCM module, even though it is not defective.

Many intermittent problems are the result of poor electrical connections. Diagnosis should start with a good visual inspection of the connectors involved with the code. Even on hard codes, visually inspect the circuit before conducting any other tests.

## VISUAL INSPECTION

Perhaps the most important check to be made before diagnosing a BCM-controlled system is a complete visual inspection. The visual inspection can identify faults that could cause the technician to spend wasted time in diagnostics. In addition, the problem can be pinpointed without any further steps.

### Inspect the following:

1. All sensors and actuators for physical damage.
2. Electrical connections into sensors, actuators, and control modules.
3. All ground connections.
4. Wiring for signs of burned or chafed spots, pinched wires, or contact with sharp edges or hot exhaust manifolds.
5. All vacuum hoses for pinches, cuts, or disconnects.

The time spent performing a visual inspection is worthwhile. Put forth the effort to check wires and hoses that are hidden under other components.

## ENTERING DIAGNOSTICS

There are as many methods of entering BCM diagnostics as there are vehicle manufacturers. Most require a scan tool (Figure 9-9). A scan tool is a microprocessor designed to communicate with the BCM. It will access trouble codes and run system operation, actuator, and sensor tests. The scan tool is plugged into the diagnostic link connector (DLC) for the system being tested. Some manufacturers provide a single DLC and the technician chooses the system to be tested through the scan tool. Always refer to the correct service information for the vehicle being serviced. Use only the methods identified in the service information for



© Delmar/Cengage Learning

**FIGURE 9-9** A scan tester is used to enter the computer's diagnostic capabilities.



### CAUTION:

The following is given as a guide and is intended to complement the service information. Improper methods of code retrieval may result in damage to the computer



### SPECIAL TOOLS

Scan tool  
Service information



### CAUTION:

The procedures may change between models, years, and the type of instrument cluster installed. Refer to the correct service manual for the vehicle being diagnosed.



### CAUTION:

Diagnosis should not be attempted if all segments do not illuminate. It is possible to misdiagnose a problem as a result of not receiving the correct code. For example, if two segments of the display fail to illuminate, a code 24 could look like code 21.

retrieving trouble codes. Once the trouble codes are retrieved, consult the appropriate diagnostic chart for instructions on isolating the fault. It is also important to check the codes in the order the manufacturer requires.

## Using a Scanner

Connecting the scan tool into the DLC will access the technician to information concerning the operation of most vehicle systems. Some scanners require the use of adapters and cartridges. Follow Photo Sequence 17 as a typical method used to enter body controller diagnostics.

When the technician has programmed the scan tester by performing the initial entries, some entry options appear on the screen. These entry options vary depending on the scan tester and the vehicle being tested. The technician presses the number beside the desired selection to proceed with the test procedure. In the first four selections, the tester is asking the technician to select the computer system to be tested. If “data line” is selected, the scan tester provides a voltage reading from each input sensor in the system.

When the technician makes a selection from the initial test selection menu, the scan tester moves on to the actual test selections. These selections vary depending on the scan tester and the vehicle being tested.

Since the scan tool provides the voltage value that the BCM is sensing from an input circuit, diagnosis of a circuit fault is made simpler. For example, if you are monitoring the input voltage of a two-wire input sensor such as the ambient temperature sensor and the scan tool indicates 5.0 volts on the circuit, this indicates the circuit has an open. The open could be anywhere in the circuit between the BCM and sensor ground (including the sensor). If the monitored voltage shows 0 volts, this usually indicates a short to ground. The short could be the sensor or in the circuit between the BCM and the sensor. A reading of 0 volts may also be caused by a faulty BCM not sending the reference voltage to the circuit.

## Cadillac BCM Trouble Code Retrieval

Many manufacturers will provide a method of retrieving diagnostic fault codes without using a scanner. The methods used to display DTCs varies greatly between manufacturers and often between different lines of the same manufacturer. Always refer to the proper service information to determine the correct procedure to retrieve DTCs. Also, beginning in 1996, many manufacturers have discontinued the practice of displaying DTCs without a scan tool. Make sure that the vehicle you are working on supports this option. The following is an example of retrieving fault codes without a scan tool.

Many Cadillac vehicles allow access to trouble codes, and other system operation information, through the electronic climate control panel (ECC). The BCM and ECM share information with each other. Thus, both ECM and BCM codes are retrieved through the ECC. To enter diagnostics, begin by placing the ignition switch in the RUN position. Depress the OFF and WARMER buttons on the ECC panel simultaneously (Figure 9-10). Hold the buttons until all display segments are illuminated.

Cadillac uses the on board ECC panel to display trouble codes, whereas other GM vehicles use a scan tool. Starting in 1996, the scan tool is used to retrieve codes on certain models. In 1996, Cadillac switched to the use of the scan tool to retrieve class 2 data. All General Motors vehicles produced in 1997 or later use the scanner. When diagnosing GM systems, make sure to follow the procedures designated by GM.

When the segment check is completed, the computer will display any trouble codes in its memory. An “8.8.8” will be displayed for about 1 second. Then an “..E” will appear. This signals the beginning of engine controller trouble codes. The display will show all engine controller trouble codes beginning with the lowest number and progressing through the higher numbers. All codes associated with the engine controller will be prefixed with an “E.” If there are



## TYPICAL PROCEDURE FOR SCAN TESTER DIAGNOSIS

All photos in this sequence are © Delmar/Cengage Learning.



**P17-1** Turn the ignition switch to the OFF position.



**P17-2** Install the proper module into the scan tool.



**P17-3** If required, connect the scan tester power cables to the vehicle's battery terminals, observing polarity.



**P17-4** Enter the model year and the VIN number code in the scan tester.



**P17-5** Select the proper scan tool data cable for the vehicle being tested.



**P17-6** Connect the scan tester cable to the DLC and turn the ignition switch to RUN.



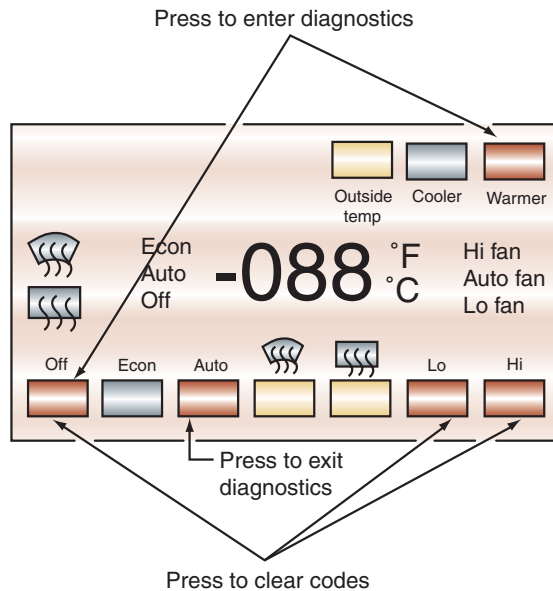
**P17-7** Select the BODY function and retrieve the DTCs with the scan tester.



**P17-8** Operate the system being diagnosed and obtain the input sensor and output actuator data with the scan tool.



**P17-9** Compare the input sensor and output actuator data to specifications in the appropriate service information. Determine data that is not written specifications.



Snapshot: Econ and Cooler

Increment: Hi

Snapshot review: Econ and Warmer

Decrement: Lo

**FIGURE 9-10** The buttons on the ECC panel allow the technician to access information from the computer when in the diagnostic mode.

© Delmar/Cengage Learning

In some GM systems, the body codes are prefixed with a "B."

If there were no trouble codes in memory, the ".7.0" will be displayed after the segment illumination test.

no codes, the ".E" will not be displayed. The "E" codes will be displayed twice. The first set of codes are all in memory, both hard and intermittent. The second set will be only hard codes. An ".E.E" is displayed to separate the two sets of codes.

Once all "E" codes are displayed, the computer will display BCM codes. The BCM codes are usually prefixed by an "F." An ".F" will precede the first set of codes displayed. The first set will be all codes stored in memory since the last 100 engine starts. An ".F.F" will appear to signal the separation of the first pass and the second. The second set of codes will be all hard codes.

When all codes are displayed, ".7.0" will be displayed. This indicates the system is ready for the next diagnostic feature to be selected. To erase the BCM trouble codes, press the OFF and LOW buttons together until "F.0.0" appears. Release the buttons and ".7.0" will reappear. Turn off the ignition switch and wait at least 10 seconds before reentering the diagnostic mode.

When in the diagnostic mode, it is possible to exit the system without erasing the trouble codes. Press AUTO on the ECC panel and the temperature will reappear in the display panel. This exits the diagnostic mode.

Some manufacturers provide a method of retrieving fault codes by displaying them in the odometer. This may be accomplished by cycling the ignition switch from OFF to RUN three times within 10 seconds. Do not start the engine. The odometer will display all of the codes then return to the odometer reading.

## TESTING ACTUATORS

Testing of actuators is included here to orient you to the basic procedures. Specific procedures will be presented throughout this manual for individual systems and types of actuators.

Most computer-controlled actuators are electromechanical devices that convert the output commands from the computer into mechanical action. These actuators are used to open

**Classroom Manual**

Chapter 9, page 255



and close switches, control vacuum flow to other components, and operate doors or valves, depending on the requirements of the system.

Most systems allow for testing of the actuator through the scan tool or while in the correct mode. Actuators that are duty cycled by the computer are more accurately diagnosed through this method. This will allow the technician to activate selected actuators to test their operation.



**WARNING:** When performing actuation tests on systems such as power windows and power seats, be sure that you not are in a position that will allow you to be pinched or caught by moving components.

If the actuator must be tested by other means than the scanner, follow the manufacturer's procedures very carefully. Because some of the actuators used by the BCM operate with 5 to 7 volts, do not connect a jumper wire from a 12-volt source unless the service information directs this. Some actuators are easily tested with a voltmeter by testing for input voltage to the actuator. If there is, input voltage of the correct level with the circuit under an electrical load, check for a good ground connection. If both of these circuits are good, then the actuator is faulty. If an ohmmeter needs to be used to measure the resistance of an actuator, disconnect the actuator from the circuit first.

An ammeter can also be used to measure the current of the actuator circuit. Simple on/off actuators should have the specified amperage anytime the actuator is energized. Higher than specified amperage reading would indicate that the actuator winding may be shorted, mechanical binding of the actuator, or a short in the circuit. Lower than specified amperage indicates high circuit resistance or the mechanical portion of the actuator is broken and thus not providing a mechanical resistance to movement. A reading of 0 amps would indicate an open in the circuit. If the actuator is controlled by pulse-width modulation, the ammeter reading should increase and decrease as the actuator pulse-width is increased and decreased, respectively.

## Scan Tool Testing of Actuators

Often, the scan tool can be used to monitor actuator operation. This is done by watching the scan tool display of the computer controlling the actuator. As the computer turns the actuator on and off, the scan tool screen will indicate this command (Figure 9-11). Keep in mind this is indicating the *attempt* of the computer to turn the actuator on and off, not necessarily that the actuator is working. While the actuator is turned on and off, a voltmeter will indicate if the voltage levels are actually changing as the state of the actuator changes.

Some actuators will provide a feedback signal to the computer of correct operation. This feedback can be in the form of a potentiometer, commutator pulses, or a hard wire input back to the computer. Sometimes the feedback is accomplished by monitoring the voltage or the amperage of the control circuit. These values may be displayed on the scan tool. Consider the circuit of a BCM-controlled relay (Figure 9-12). With the relay de-energized the computer should see battery voltage on the control circuit. With the relay energized, the computer should see close to 0 volts. This may be also displayed as "High" or "Low"; or "True" or "False" on the scan tool (Figure 9-13).

Figure 9-14 illustrates an activator circuit that monitors the current flow. In the case the scan tool may display the interrupted current (Figure 9-15). This value should match the reading of a connected ammeter. Keep in mind that the scan tool may display 0 amps anytime the computer detects a fault in the circuit. The fault may be an open, short to ground, or any high current draw condition that will cause the microprocessor to shut down the circuit driver to prevent damage.



### SPECIAL TOOLS

Scan tool

DMM

Service information

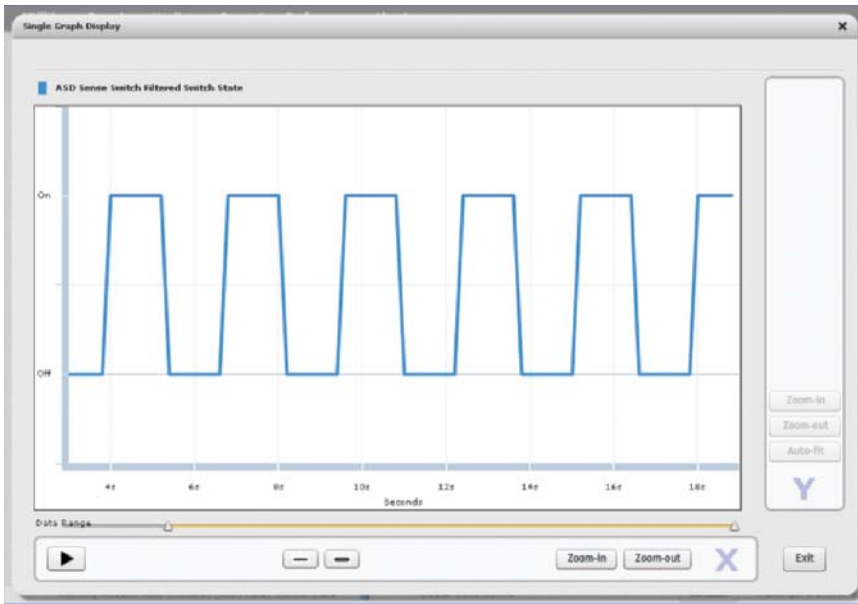


FIGURE 9-11 The scan tool may be capable of displaying the command of the computer to the actuator.

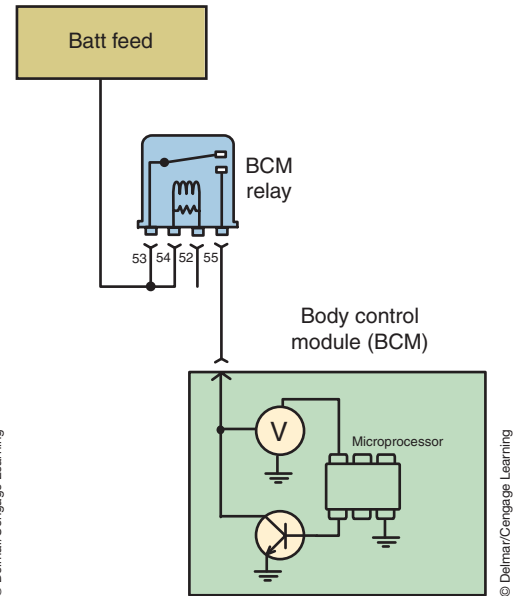


FIGURE 9-12 BCM relay driver control circuit.

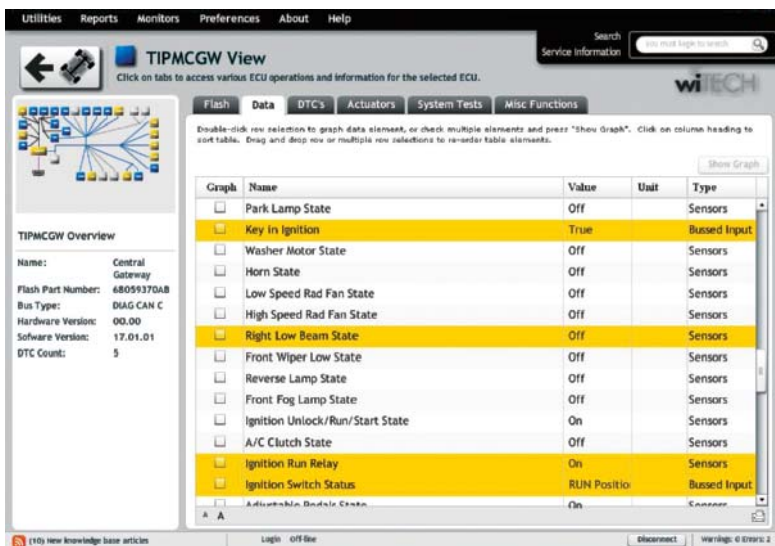


FIGURE 9-13 Scan tool display of the operation for the control side of an actuator.

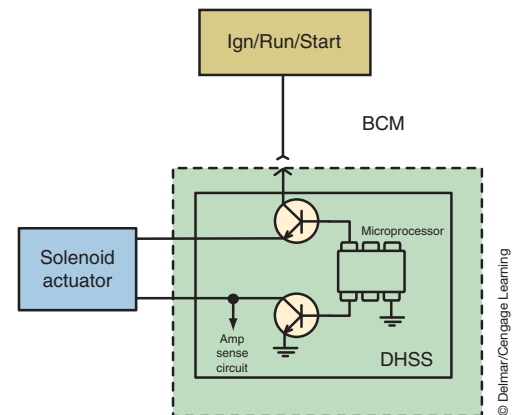


FIGURE 9-14 Dual high-side switch function that measures circuit current.

An additional function of the scan tool is the capacity to request an **activation test** (Figure 9-16). The scan tool activation tests places the scan tool into the function of the input to request the computer to follow through with the operation of the actuator. While the activation is being performed, a voltmeter or ammeter can be used to confirm the request is being performed. Often the activation can be observed by watching the actuator move. If the activation test works, but normal operation fails, then the problem is likely in the inputs to the computer.

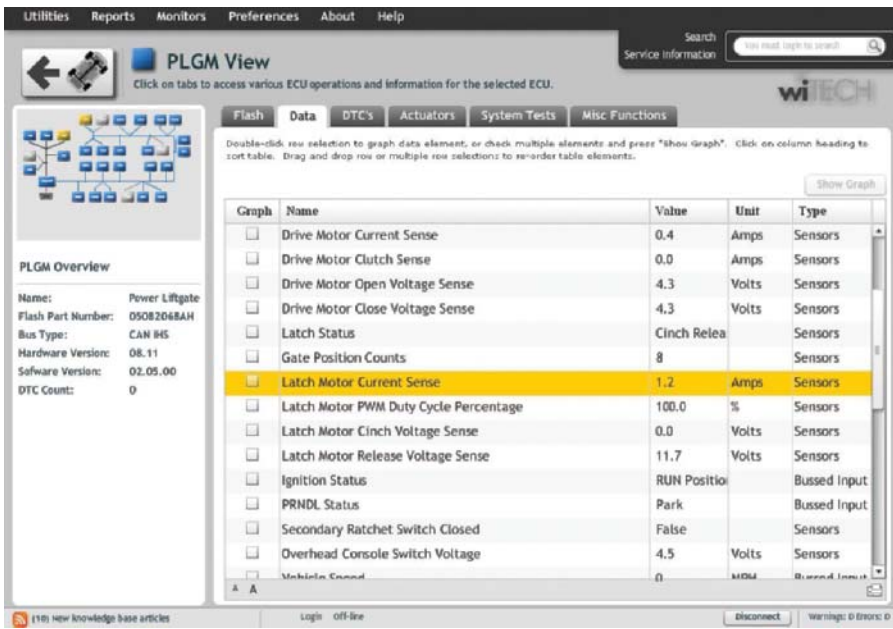


FIGURE 9-15 Scan tool display of the current required for the operation for the actuator.

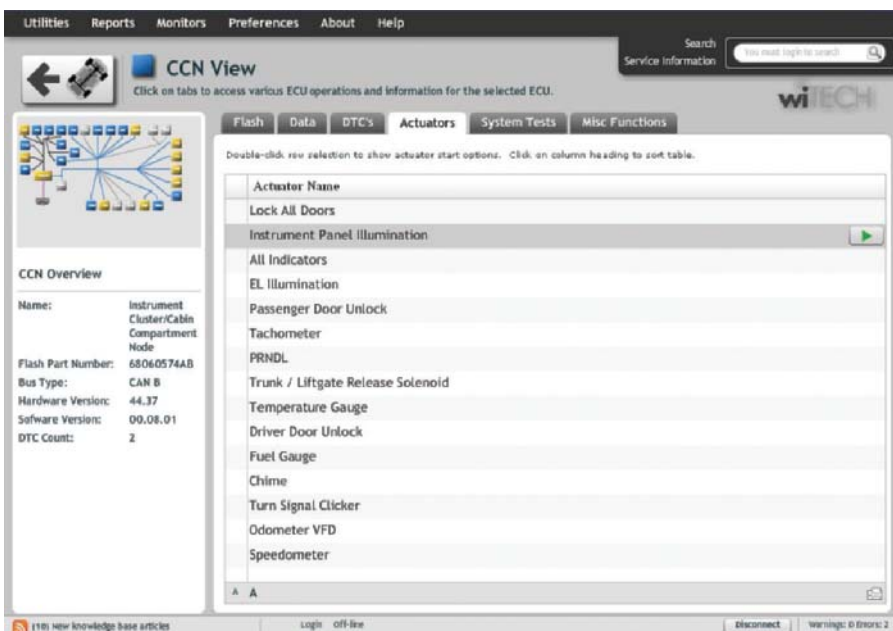


FIGURE 9-16 List of actuation tests that are available for this particular vehicle.

## Testing Actuators with a Lab Scope

Since most actuators are electromechanical devices, when they fail it is because they are electrically faulty or mechanically faulty. By observing the action of an actuator on a lab scope, you will be able to watch an actuator's electrical activity. Normally, if there is a mechanical fault, it will affect the activator's electrical activity as well. Therefore, you get a good sense of the actuator's condition by watching it on a lab scope.

To test an actuator, you need to know what type it is. Most actuators are solenoids. The computer controls the action of the solenoid by controlling the pulse width of the control signal. By watching the control signal, you can see the turning on and off of the solenoid (Figure 9-17). The voltage spikes are caused by the discharge of the coil in the solenoid.



### SPECIAL TOOLS

Lab scope  
Service information



Both waveforms should be checked for amplitude, time, and shape. You should also observe changes to the pulse width as operating conditions change. A bad waveform will have noise, glitches, or rounded corners. You should be able to see evidence that the actuator immediately turns on and off according to the commands of the computer.

## FLASHING THE BCM

Many modern BCMs are produced with EEPROM chips that allow the basic programming of the computer to be altered or rewritten. This enables manufacturers to reduce costs by having the technician **flash** the computer instead of replacing it. To flash a computer means to remove the existing programming and overwrite it with new software. New program instructions are downloaded into the scan tool and then downloaded into the BCM over a dedicated circuit.

Each scan tool is a little different in the procedure used to obtain a download and to flash the BCM. Some scan tools are connected to a PC and the software is transferred from a CD-ROM disc or from an Internet site. Some scan tools are connected directly to a LAN and obtain the flash from the Internet site. Usually the automotive shop has to pay a subscription fee to obtain these downloads. Photo Sequence 18 shows a typical procedure for flashing a BCM. It is important to follow the service information procedures for the vehicle you are working on. Also, connecting a battery charger to keep the battery at 13.5 volts will prevent problems during the download resulting from low battery voltage. Be sure to check and clear any DTCs that may have been set during the flash procedure.

**Classroom  
Manual**

Chapter 9, page 247



**SPECIAL TOOL**

Scan tool

## PHOTO SEQUENCE 18

### FLASHING A BCM

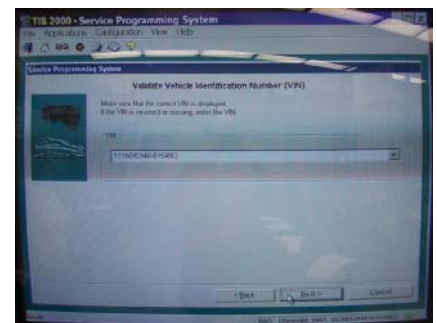
All photos in this sequence are © Delmar/Cengage Learning.



**P18-1** Use the scan tool to obtain the part number of the BCM and record the number.



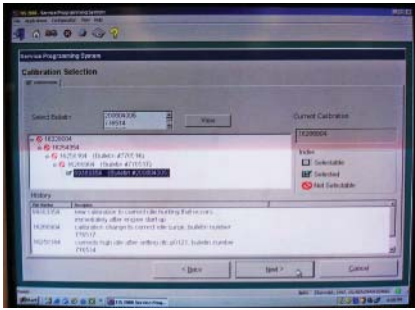
**P18-2** Connect the scan tool to a PC that links the scanner to the flash software. Some scan tools will connect directly to an Internet site through a LAN.



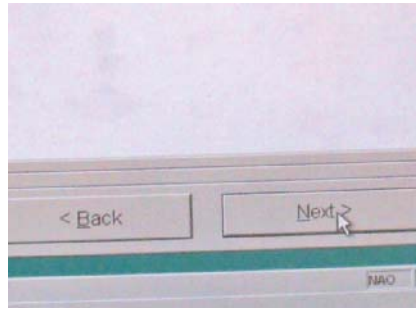
**P18-3** Enter the BCM part number in the field and select the "Show Updates" button.



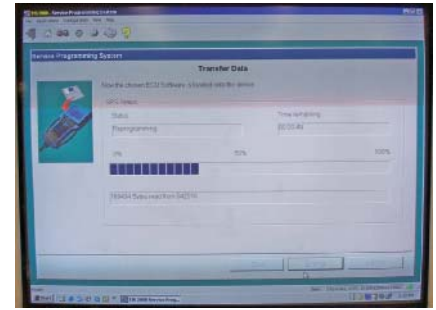
## PHOTO SEQUENCE 18 (CONTINUED)



**P18-4** Select the desired flash file.



**P18-5** Select the “Download/Update” button.



**P18-6** Monitor the progress of the download to the scan tool.



**P18-7** After successful download, return to the vehicle and connect a battery charger to the vehicle's battery. Maintain about 13.5 volts on the battery.



**P18-8** Connect the scan tool to the DLC and power the tool on.



**P18-9** Navigate the scan tool to perform the desired flash. Follow the instructions that are displayed on the screen.

### TERMS TO KNOW

- Activation test
- Breakout box
- Diagnostic and trouble code (DTC)
- Electrostatic discharge (ESD) strap
- Fail soft
- Flash
- Flash codes
- Hard codes
- Impedance
- Intermittent codes

### CASE STUDY

A customer is experiencing intermittent problems with several electrical options on their vehicle. The customer states that either the systems will operate erratically or stop operating completely. Retrieval of DTCs indicates several codes in many of the vehicle modules. Most of the DTCs relate to improper input values or feedback signals. The technician asks the customer if any services have been performed on the vehicle lately and is informed that some body work was done a couple of weeks ago. Realizing that all of the DTCs are actually related to a possible single cause, the technician performs a visual inspection of

all ground straps. He locates a ground strap that is disconnected between the bulkhead and the engine hood. He repairs this connection and continues to verify that all grounds are properly connected. The disconnected ground strap was used to suppress EMI that can result from the sheet metal behaving as a capacitor and the air space between the sheet metal forming an electrostatic field. Without proper grounding of the sheet metal, interference with computer-controlled circuits that are routed near the sheet metal can result. Upon verifying the repair, the vehicle was returned to the customer.



## ASE-STYLE REVIEW QUESTIONS

- All of the following statements about servicing the BCM are true EXCEPT:
  - Always check voltage supply circuits before replacing the BCM.
  - Analog voltmeters must be used to test circuit voltage.
  - Always check grounds before replacing the BCM.
  - Turn the ignitions switch to the OFF position before disconnecting or connecting components.
- Diagnostic trouble codes are being discussed.

*Technician A* says hard code failures are those that have occurred in the past but were not present during the last BCM test of the circuit.

*Technician B* says intermittent codes are those that were detected the last time the BCM tested the circuit.

Who is correct?
  - A only
  - B only
  - Both A and B
  - Neither A nor B
- Technician A* says DTCs will indicate the exact failure in the circuit.

*Technician B* says DTCs will direct the technician to the circuit with a fault in it.

Who is correct?
  - A only
  - B only
  - Both A and B
  - Neither A nor B
- Accessing trouble codes through the ECC on General Motors vehicles is being discussed.

*Technician A* says depress the OFF and WARMER buttons simultaneously.

*Technician B* says the body codes are prefixed with an "E."

Who is correct?
  - A only
  - B only
  - Both A and B
  - Neither A nor B
- When flashing a computer, all of the following are true EXCEPT:
  - A battery charger should be connected to the vehicle's battery.
  - Special instructions may be displayed on the scan tool screen during the flash.
  - The flash process loads new software programming into the computer.
  - The BCM must be removed from the vehicle before it is flashed.
- Technician A* says open circuit testing of the BCM power supplies will indicate if there is high resistance in the circuit.

*Technician B* says that open circuit testing has the potential to mislead to improper diagnostics.

Who is correct?
  - A only
  - B only
  - Both A and B
  - Neither A nor B
- If the scan tool fails to make connection with the BCM, all of the following could be the cause *except*:
  - Loss of BCM power ground.
  - Open actuator circuit.
  - Open battery feed circuit to the BCM
  - Faulty scan tool.
- Technician A* says that a PWM actuator cannot be tested with a DMM.

*Technician B* says the PWM actuator may be tested with a lab scope.

Who is correct?
  - A only
  - B only
  - Both A and B
  - Neither A nor B
- A high-side controlled actuator fails to operate. The scan tool displays 0 amps on the control circuit when the system is attempted to be turned on.

*Technician A* says this may indicate an open in the circuit.

*Technician B* says this may indicate a short to ground in the circuit.

Who is correct?
  - A only
  - B only
  - Both A and B
  - Neither A nor B
- The relay coil circuit is controlled by a low-side driver. Direct battery feed is connected to the other terminal of the coil. If the BCM monitors voltage on the control circuit to determine proper operation, which of the following statements is **not** true?
  - The voltage reading by the BCM before the low-side driver should be battery voltage with the coil turn off.
  - The voltage reading by the BCM before the low-side driver should be close to 0 volts with the coil turn on.
  - A constant low voltage reading by the BCM may be the result of an open in the circuit between the battery and the coil.
  - The BCM will not be capable of setting control circuit faults.

## ASE CHALLENGE QUESTIONS

- The radiator/condenser fan of a BCM-equipped vehicle is operating at full speed whenever the engine is running.

*Technician A* says that the coolant temperature sensor may be open.

*Technician B* says that for some reason the BCM may have initiated a fail soft action.

Who is correct?

A. A only                      C. Both A and B  
B. B only                      D. Neither A nor B
- BCM system troubleshooting is being discussed.

*Technician A* says that if the BCM “sees” a problem with any of its input sensors or output devices it will always command the “service engine” lamp to illuminate.

*Technician B* says that most diagnostic charts cannot be used to diagnose intermittent problems.

Who is correct?

A. A only                      C. Both A and B  
B. B only                      D. Neither A nor B
- The in-car temperature sensor of a vehicle equipped with a BCM and automatic temperature control (ATC) occasionally shorts internally, resulting in erratic operation of the ATC system. However, when the vehicle is brought into the shop for testing, the ATC system performs correctly.

*Technician A* says that an intermittent trouble code will be stored by the BCM.

*Technician B* says that an intermittent and a hard trouble code will be stored by the BCM.

Who is correct?

A. A only                      C. Both A and B  
B. B only                      D. Neither A nor B
- The diagnosis of BCM-controlled output actuators is being discussed.

*Technician A* says that the speed of the radiator fan motor can be controlled and monitored by pressing certain buttons on the ECC display.

*Technician B* says that some scan tools can control the operation of output actuators.

Who is correct?

A. A only                      C. Both A and B  
B. B only                      D. Neither A nor B
- An actuator that receives direct battery feed and is controlled by a low-side driver has a short to ground in the control circuit.

*Technician A* says this may cause the battery to drain overnight.

*Technician B* says the BCM will no longer have control of the system and may set a DTC.

Who is correct?

A. A only                      C. Both A and B  
B. B only                      D. Neither A nor B
- The flashing of a computer is done to perform which task?

A. Repair hardware problems with in the computer-controlled system.  
B. To update the software within the computer to correct or enhance operation.  
C. Determine if driver habits contribute to EEPROM issues.  
D. Correct for faulty input signals.
- Which method may be used to check a computer-controlled actuator?

A. Use a lab scope to monitor voltage levels.  
B. Use an ammeter to monitor current flow.  
C. Use a scan tool to activate the component.  
D. All of the above.
- When measuring the voltage on the power feed circuit to the computer, the voltmeter reads 12 volts with the connector unplugged. When load tested with a test light the voltmeter reads 12 volts. When the connector is plugged back in and backprobed, the voltmeter reads 9.5 volts.

*Technician A* says this may be due to an internal problem in the computer.

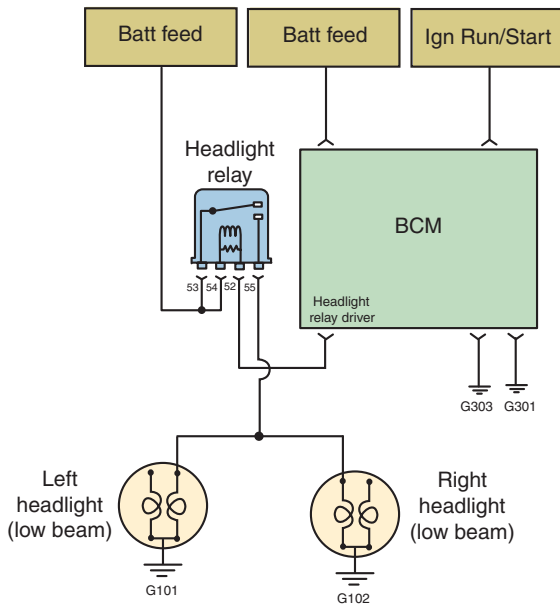
*Technician B* says this may be due to an open computer ground circuit.

Who is correct?

A. A only                      C. Both A and B  
B. B only                      D. Neither A nor B
- The scan tool indicates that an actuator is being turned on and off; however the actuator does not operate. What is the *least* likely cause?

A. Faulty computer.  
B. Open in the control circuit of the actuator.  
C. Open in the ground circuit of the actuator.  
D. Defective actuator device.

10. Using Figure 9-19 of a computer-controlled headlight system; the headlights operate dimly on both sides. What is the most likely cause?
- A. Poor battery feed connection to the BCM.
  - B. Worn or corroded relay contacts.
  - C. Weak headlamps.
  - D. High resistance in the headlamp ground circuits.



**FIGURE 9-19**

*This page intentionally left blank*

Name \_\_\_\_\_ Date \_\_\_\_\_

### Testing Computer Power and Ground Circuits

Upon completion of this job sheet, you should be able to flash a BCM.

#### Describe the vehicle being worked on

Year \_\_\_\_\_ Make \_\_\_\_\_ Model \_\_\_\_\_

VIN \_\_\_\_\_ Engine type and size \_\_\_\_\_

#### Tools and Materials

DMM

Test light

Breakout box

Backprobe tools

Service information

#### Procedure

1. Using the proper service information, identify the following information for each direct battery feed circuit:  
 BCM connector number and cavity: \_\_\_\_\_  
 Circuit identification: \_\_\_\_\_  
 Wire color code: \_\_\_\_\_
  
2. Identify the following information for each ignition feed or switched battery feed circuit:  
 BCM connector number and cavity: \_\_\_\_\_  
 Circuit identification: \_\_\_\_\_  
 Wire color code: \_\_\_\_\_
  
3. Identify the following information for each ground circuit:  
 BCM connector number and cavity: \_\_\_\_\_  
 Circuit identification: \_\_\_\_\_  
 Wire color code: \_\_\_\_\_
  
4. Identify the following information for each sensor return circuit:  
 BCM connector number and cavity: \_\_\_\_\_  
 Circuit identification: \_\_\_\_\_  
 Wire color code: \_\_\_\_\_
  
5. Disconnect the connector(s) that contain the direct battery feed circuits and measure the voltage at each of the battery feed terminals.  
 \_\_\_\_\_  
 \_\_\_\_\_  
 \_\_\_\_\_  
 \_\_\_\_\_

6. Use a test light to load the circuit and retest the battery voltage at each terminal identified in step 1. Record your results.

---

---

---

7. Were the reading different between those taken in step 5 and step 6?  Yes  No  
Explain why or why not.

---

---

8. Reconnect the connector(s) and backprobe the terminals and measure the direct battery voltage circuits identified in step 1. Record your results.

---

---

---

9. If any of the direct battery feed circuits voltage values were below specifications, what would your next step be?

---

---

---

10. Test each of the ignition or switched battery feed circuits identified in step 2 using open circuit, test light load, and backprobing methods and record your conclusions.

---

---

---

---

11. Disconnect the connector(s) that contain the circuits for the BCM grounds and measure the voltage at each of the ground terminals. Record your results.

---

---

12. Use a test light connected to battery positive to load the ground circuits and re-measure the voltage.

---

---

13. Reconnect the BCM connector and backprobe the ground circuits to measure voltage with the ignition in the RUN position. Record your results.

---

---

14. Disconnect the negative battery terminal and test the BCM ground circuits using an ohmmeter to test continuity from the disconnected BCM connector(s) and chassis ground. Record your results.

---

---



**15.** Comparing the tests performed on the ground circuit in steps 11 through 14, which do you believe to be the most accurate method of locating circuit faults and why?

---

---

---

**16.** Describe how you would proceed to test the sensor return circuit.

---

---

---

**17.** After reviewing step 16 with your instructor, perform the test you outlined and record your results.

---

---

---

Instructor's Response \_\_\_\_\_

---

---

*This page intentionally left blank*

Name \_\_\_\_\_ Date \_\_\_\_\_

## USING A SCAN TOOL

Upon completion of this job sheet, you should be able to hook up a scan tool and retrieve the codes from a computer.

### ASE Correlation

This job sheet is related to the ASE Electrical/Electronic System Certification Exam's content area: *General Electrical System Diagnosis*; task: Use scan tool data to diagnose electronic systems; interpret readings and determine needed repairs.

### Tools and Materials

Vehicle equipped with a BCM  
Scan tool

### Describe the vehicle being worked on:

Year \_\_\_\_\_ Make \_\_\_\_\_ Model \_\_\_\_\_  
VIN \_\_\_\_\_ Engine type and size \_\_\_\_\_

### Procedure

Task Completed \_\_\_\_\_

1. Locate the data link connector for the BCM. Where is the connector located?  
\_\_\_\_\_  
\_\_\_\_\_
2. Connect the scan tool to the DLC and turn the ignition switch to the RUN position. What version is the scan tool software?
3. Select the body computer function. Record the following information about the BCM:  
Part Number: \_\_\_\_\_  
Software Version: \_\_\_\_\_  
Hardware Version: \_\_\_\_\_
4. How is this information useful?  
\_\_\_\_\_  
\_\_\_\_\_  
\_\_\_\_\_  
\_\_\_\_\_
5. Retrieve any fault codes that may be in the BCM's memory. Record the codes below.  
\_\_\_\_\_  
\_\_\_\_\_  
\_\_\_\_\_  
\_\_\_\_\_
6. Are the fault codes' hard codes or intermittent? \_\_\_\_\_

---

**Task Completed**

7. For the system with fault code retrieved in step 5, use the scan tool to monitor the desired state of the actuator while you attempt to operate the system inputs. Describe your results.

---

---

---

8. Identify the control and ground circuit for the actuator.

---

---

---

9. Following recommended practices of the vehicle manufacturer, either backprobe the actuator connector, use a jumper harness, or use a breakout box to measure the voltage on each circuit with the ignition key off.

---

---

---

10. Repeat step 9 with the ignition switch in the RUN position.

---

---

---

11. Observe the voltmeter reading while attempting to operate the system and record your results.

---

---

---

12. Based on your testing thus far, can you make any conclusions?

---

---

---

13. Connect an ammeter to the control circuit of the actuator and attempt to operate the system again. Record your results.

---

---

---

14. Use the scan tool's activation test function to command the operation of the actuator while observing the ammeter. Explain your results.

---

---

---

15. Remove the ammeter from the circuit and replace it with a lab scope. Repeat step 14 and record your results.

---

---

---

16. What are your conclusions?

---

---

---

Instructor's Response \_\_\_\_\_

---

---

*This page intentionally left blank*



Name \_\_\_\_\_ Date \_\_\_\_\_

## FLASHING A BCM

Upon completion of this job sheet, you should be able to flash a BCM.

### Tools and Materials

- Scan tool
- Access to flash software
- Battery charger

### Describe the vehicle being worked on:

Year \_\_\_\_\_ Make \_\_\_\_\_ Model \_\_\_\_\_  
 VIN \_\_\_\_\_ Engine type and size \_\_\_\_\_

### Procedure

\_\_\_\_\_  
 Task Completed

1. Is there a TSB that addresses flashing the BCM for your assigned vehicle?  Yes  No  
 If yes, what is the document number? \_\_\_\_\_  
 If no, go to step 3.
  
2. According to the TSB, what is the purpose of the flash?  
 \_\_\_\_\_  
 \_\_\_\_\_  
 \_\_\_\_\_
  
3. Connect the scan tool to the DLC and access the BCM. Obtain the BCM part number and record. \_\_\_\_\_
  
4. Describe the procedure used to obtain the flash download into your scan tool.  
 \_\_\_\_\_  
 \_\_\_\_\_
  
5. Follow the procedure outlined in step 4 and download the flash file to your scan tool. Describe the navigation required to download the file to the scan tool.  
 \_\_\_\_\_  
 \_\_\_\_\_
  
6. How do you know the download was successful?  
 \_\_\_\_\_  
 \_\_\_\_\_
  
7. Return to the vehicle and connect a battery charger to the battery. Why is this step important?  
 \_\_\_\_\_  
 \_\_\_\_\_

Task Completed

8. Perform the flash of the BCM. Record any steps the scan tool directs you to perform during the flash.

---

---

---

9. How do you know if the flash update was successful?

---

10. After the flash is completed, check for DTCs. Were any DTCs set?  Yes  No  
If yes, erase DTCs.

Instructor's Response

---

---

<b>DIAGNOSTIC CHART 9-1</b>	
PROBLEM AREA:	Scan tool does not connect to the BCM.
SYMPTOMS:	No response from the BCM.
POSSIBLE CAUSES:	1. Poor connection at the DLC. 2. Loss of battery feed to the DLC. 3. Loss of ground connection at the DLC. 4. Loss of BCM ground connection(s). 5. Loss of direct battery feed circuits to the BCM. 6. Loss of ignition switch or switched battery feed circuits to the BCM. 7. Faulty scan tool. 8. Defective BCM.

<b>DIAGNOSTIC CHART 9-2</b>	
PROBLEM AREA:	BCM functions.
SYMPTOMS:	No BCM functions and safety systems are in default mode.
POSSIBLE CAUSES:	1. Loss of BCM ground connection(s). 2. Loss of direct battery feed circuits to the BCM. 3. Loss of ignition switch or switched battery feed circuits to the BCM. 4. Defective BCM.

<b>DIAGNOSTIC CHART 9-3</b>	
PROBLEM AREA:	BCM software.
SYMPTOMS:	TSB update and/or improper system operation.
POSSIBLE CAUSES:	1. BCM requires flashing. 2. Defective BCM.

<b>DIAGNOSTIC CHART 9-4</b>	
PROBLEM AREA:	Activators.
SYMPTOMS:	System fails to function.
POSSIBLE CAUSES:	<ol style="list-style-type: none"><li>1. Blown circuit fuse.</li><li>2. Open in the control circuit.</li><li>3. Open in the ground circuit.</li><li>4. Faulty actuator.</li><li>5. Open or poor BCM power and ground circuits.</li><li>6. Defective BCM.</li></ol>

*This page intentionally left blank*

## SENSOR DIAGNOSTIC ROUTINES



### BASIC TOOLS

Basic hand tools

Service information

### UPON COMPLETION AND REVIEW OF THIS CHAPTER, YOU SHOULD BE ABLE TO:

- Comprehend the complexities of diagnosing intermittent faults.
- Properly utilize all tools and tool features to isolate the cause of an intermittent fault.
- Test thermistors used for temperature sensing for proper operation.
- Diagnose the thermistor circuit for proper operation.
- Properly determine if the PTC circuit protection device is intact or defective.
- Perform proper diagnostics of pressure switch inputs.
- Properly diagnose Wheatstone bridge pressure sensors and their circuits.
- Diagnose frequency-generating capacitance discharge sensors.
- Determine proper operation of a pressure sensor by monitoring its signal with a lab scope.
- Use a DMM or lab scope to test and determine needed repairs of the potentiometer and its circuits.
- Use a DMM to diagnose the magnetic induction sensor.
- Use a DMM to diagnose the magnetic induction sensor output.
- Use a lab scope to determine magnetic induction sensor output functionality.
- Determine causes for magnetic induction sensor dropout.
- Properly diagnose the magnetic induction sensor circuits for opens, shorts, and short to ground conditions.
- Use a scan tool to diagnose the magnetic induction sensor.
- Use a DMM, scan tool, and lab scope to diagnose magnetoresistive (MR) sensors.
- Use a DMM, scan tool, and lab scope to diagnose the MR sensor circuits for opens, shorts, and short to ground conditions.
- Use a lab scope and DMM to determine proper operation of the Hall-effect sensor and its circuits.

### INTRODUCTION

Inputs are used by the automotive computer as a means of gathering information. Missing or corrupted input data results in poor system performance. This chapter explores the methods used to diagnose temperature sensors, different types of pressure sensors, position sensors, motion detection sensors, and the related circuits for each.

All sensor diagnostics begin with a thorough inspection of the sensor and its related circuits. This includes looking for physical damage and proper electrical connection. If a sensor has a hose or other mechanical connection, it must also be inspected. In addition, carefully examine the wiring harness and connectors between the sensor and the control module, including any dedicated ground circuits. All connectors and connector terminals

must be tested for looseness, pullout, or damage. Any other conditions that can cause the sensor to not perform properly must be investigated.

Examples of diagnostic routines will be provided. Although the diagnostics discussed may pertain to a specific function, the diagnostics of the circuits of most sensor types will be compatible.

## INTERMITTENT FAULTS

Probably one of the most aggravating situations for the vehicle owner is to have their vehicle returned with “No Problem Found” noted on the repair order. It is also very aggravating to the technician when they are unable to duplicate the problem the customer is experiencing. Intermittent problems challenge the technician to really examine the system to determine possible causes for the fault. The answer is not to throw parts at it; instead a methodical diagnostic routine must be utilized.

Intermittent faults with sensors will usually set a DTC. However, the DTC will be stored instead of being active when the technician retrieves them. This means the fault occurred at some point, but is not active right now and that the conditions necessary to set this DTC are not present at this time.

Begin by reviewing any technical bulletins that are related to the problem the customer is experiencing. Perform any repairs directed by the bulletin. If there is not a bulletin that addresses the concern, continue with the diagnostics. This includes a thorough visual inspection of the sensor, sensor circuit wires, connectors, and terminals. Most intermittent conditions are the result of a poor connection somewhere in the circuit. It is a good practice to disconnect and clean all grounds involved in the system. If there are multiple stored DTCs, use the wiring information to determine common connections or grounds for all of the effected circuits. If the visual inspection fails to isolate the cause, further testing will need to be performed.

If the scan tool provides **environmental data** information that is associated with the stored DTC, this may be helpful in duplicating the problem. Environmental data is a snapshot of the conditions when the fault occurred. It will also indicate how many ignition cycles ago the fault was set and how long it was an active fault (Figure 10-1). In addition, OBD II faults may have an associated **freeze frame** with the DTC (Figure 10-2). Freeze frame is similar to environmental data, but contains OBD II mandated information for when the fault first occurred. Both of these will assist the technician in determining the operating conditions that set the code so they can attempt to duplicate the conditions.

Next, use the scan tool to clear the DTC. With the ignition in the RUN position, monitor the scan tool for at least two minutes while wiggling the harness and connectors for the sensor circuits. Monitor the scan tool while looking for the sensor data to change or for the DTC to reset. If this does not cause a change in the sensor data or the DTC to return, cycle the ignition key off and on several times, leaving the ignition on for at least 10 seconds at a time. If the DTC does not return after this test, start the engine and allow it to reach normal operating temperature.

If the code appears during any of the tests, then perform the diagnostic routines for an active code. If the code does not return, duplicate the conditions indicated by the environmental or freeze frame data. Using the data recording function of the scan tool may assist the technician in locating the fault. Also, a lab scope is a very useful tool to help diagnose intermittent conditions.

**CUSTOMER CARE:** If you are unable to duplicate an intermittent fault, do not attempt the repair by guessing. Some scan tool and OEM manufacturers provide a data recording tool that can be connected to the vehicle’s bus network. When the problem the owner is experiencing occurs, they push a button and the data recording is saved. Upon returning to the shop, the technician is then able to retrieve the information and pinpoint the root cause.



### SPECIAL TOOLS

Jumper wire  
Scan tool  
DMM  
Backprobing tools



### SERVICE TIP:

Do not erase the fault code until environmental or freeze frame data has been reviewed. Clearing the DTC may also clear this data.



EV Data-PCM			
Names	Value	Units	Toggle Row Height
Manifold Absolute Pressure Sensor Circuit High	P0108		
DTC Readiness Flag	Not Complete		
Odometer	1232.8	miles	
Starts Since Set Counter	3		
Warning Indicator Request State	On		
Good Trip Counter	0		
DTC	01 08		
Number DTC	1		
Ignition Key Cycles	3		
Accumulation Timer	3	minutes	
Warm Up Cycles	0		
Key Cycles Since DTC Last Set Counter	4		
DTC Storage State	Stored		

© Delmar/Cengage Learning

FIGURE 10-1 Scan tool screen showing the details associated with the setting of a fault code.

CARB			
	Name	Value	Units
▲	PCM Mileage Since MIL On	0.0	miles
	Freeze Frame Caused by DTC	01 08	
	Freeze Frame DTC Priority	03	
	PCM Odometer	1236.9921	miles
	Open Loop due to Driving Conditions - Bank 2	False	
	Open Loop - Bank 1	False	
	Closed Loop - Bank 1	True	
	Open Loop with DTC - Bank 1	False	
	Closed Loop with DTC - Bank 1	False	
	Open Loop due to Driving Conditions - Bank 1	False	
	Open Loop - Bank 2	False	
	Closed Loop - Bank 2	True	
	Open Loop with DTC - Bank 2	False	
	Closed Loop with DTC - Bank 2	False	
	MAP	15	psl
	MAP Voltage	4.94	Volts
	Calculated MAP	8.0	psl
	Vacuum	16.17	in Hg
	Barometric Pressure	15	psl
	Engine Load	58.8	%
	TPS 2 Voltage	4.22	Volts
	APP Pedal Percent	0.0	%
▼	APP 1 Voltage	0.4497	Volts
	APP 2 Voltage	0.22	Volts

© Delmar/Cengage Learning

FIGURE 10-2 Partial screen capture of scan tool display for freeze frame.

## DIAGNOSING TEMPERATURE SENSORS AND THEIR CIRCUITS

Temperature sensors of various types are used in several different systems on today's vehicles. Due to their prominence, it is imperative that today's technician be able to competently diagnose these sensors and their associated circuits. This section details diagnostic routines for the most common forms of temperature-sensing systems.

### Classroom Manual

Chapter 10, page 261



### SPECIAL TOOLS

DMM  
Scan tool  
Lab scope  
Jumper wires  
Backprobing tools

Dual ramping is also referred to as dual resolution or dual range.

### Classroom Manual

Chapter 10, page 263

### Diagnosing Thermistor Circuits

A **thermistor** is a solid-state variable resistor made from a semiconductor material that changes resistance as a function of temperature. By monitoring the resistance value of the thermistor, the control module is capable of observing very small changes in temperature. A reference voltage is sent from the control module to the thermistor through a fixed resistor. As the current flows through the thermistor resistance to ground, a voltage-sensing circuit measures the voltage after the fixed resistor (Figure 10-3). The voltage dropped over the fixed resistor will change as the resistance of the thermistor changes. Using its programmed values, the control module is able to translate the voltage drop into a temperature value.

Two types of thermistors are used to measure temperature changes. **Negative temperature coefficient (NTC)** thermistors reduce their resistance as the temperature increases. **Positive temperature coefficient (PTC)** thermistors increase their resistance as the temperature increases.

Regardless of the purpose or type, the thermistor circuits operate under the same principles. In most cases, a problem in the circuit will be detected by the control module and a DTC will be recorded. The DTC can relate to a circuit voltage too high, circuit voltage too low, or a rationality fault.

Some systems will use a **dual ramping** sensor circuit. The control module switches internal resistors at a specified temperature. This resistance change inside the control module causes a significant change in voltage drop across the sensor as indicated in the specifications (Figure 10-4). This is a normal condition on any control module with this feature. This change in voltage drop is always evident in the vehicle manufacturer's specifications.

The temperature sensor can be tested while they are installed in the system by backprobing the terminals to connect a digital voltmeter or lab scope to the sensor terminals.

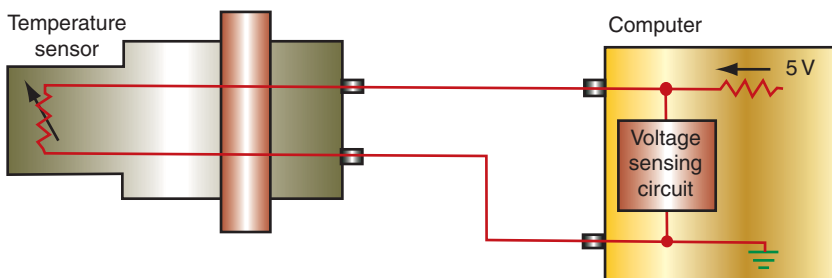
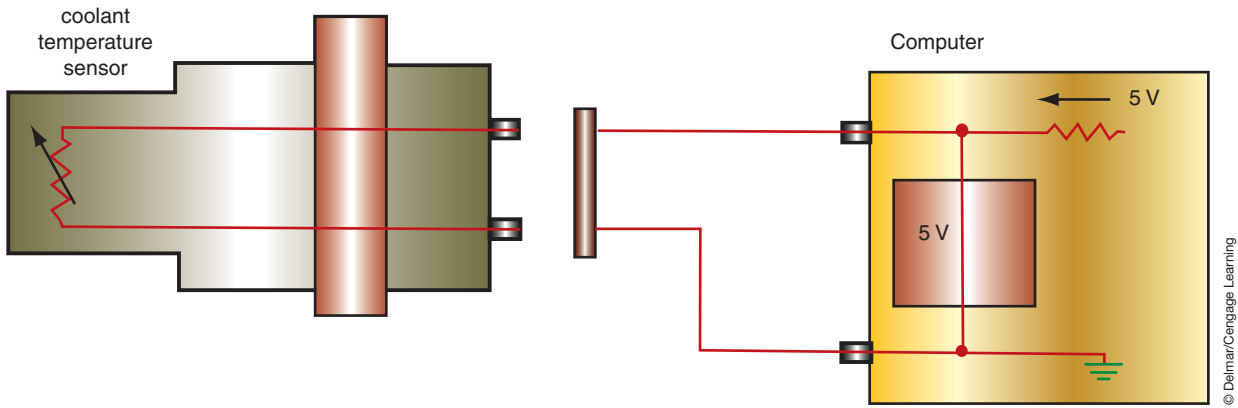


FIGURE 10-3 Engine coolant temperature sensor circuit.

COLD	HOT
10 K-Ω resistor	909-Ω resistor
-20° F 4.7V	110° F 4.2V
0° F 4.4V	130° F 3.7V
20° F 4.1V	150° F 3.4V
40° F 3.6V	170° F 3.0V
60° F 3.0V	180° F 2.8V
80° F 2.4V	200° F 2.4V
100° F 1.8V	220° F 2.0V
120° F 1.2V	240° F 1.6V

FIGURE 10-4 Example of voltage specifications for the ECT sensor.



**FIGURE 10-5** Disconnecting the sensor should cause the controller to register 5 volts. This will be the voltage displayed on the scan tool.

should provide the specified voltage drop at any temperature. The scope trace of an NTC thermistor should indicate a smooth transition from a high voltage (about 4.0 volts) to a low voltage as the sensor warms.

If the system uses dual ramping, there should be a change in voltage to a higher reading at the specified voltage or temperature reading. If this switch does not occur, the fault is within the control module.

Consider Figure 10-3 above as an example for circuit diagnosis. Simply disconnect the sensor and observe the voltage on the scan tool. The displayed voltage should equal that used by the control module circuit (Figure 10-5). If the voltage displayed by the scan tool is 0, the problem is either the signal circuit is shorted to chassis ground or to the sensor ground circuit, or a faulty control module.

If the specified voltage is present with the sensor unplugged, use a jumper wire to connect the two terminals at the sensor harness connector. The scan tool should display 0 volts. If the voltage is still 5 volts, connect the signal circuit wire to chassis ground. If the reading is now 0 volt, the sensor ground circuit is open. While doing these steps if the voltage is above 0 volts (but less than 5 volts), this indicates resistance in the circuit (Figure 10-6). If the

Data Display - PCM			
	Name	Value	Unit
▲	fuel Level Percent	49.0	%
	Engine Coolant Temp	120.2	F
	Engine Coolant Temp Volt	0.0587	Volts
	Intake Air Temp Deg	93.2	F
	Intake Air Temp Volt	3.1821	Volts
	Ambient Temp	44.6	F
	Ambient Temp Voltage	2.69	Volts
▼	CAT Modeled Temp	-83.2	F

**FIGURE 10-6** This voltage displayed on the scan tool indicates that there is resistance in the circuit.



**CAUTION:**

Before disconnecting any computer system component, be sure the ignition switch is turned off. Disconnecting components may cause high induced voltages and computer damage.



**CAUTION:**

Never apply an open flame to a coolant temperature for test purposes. This action will damage the sensor.



**SERVICE TIP:**

Because current flow through the sensor will affect the readings, do not leave the ohmmeter connected for longer than 15 seconds.

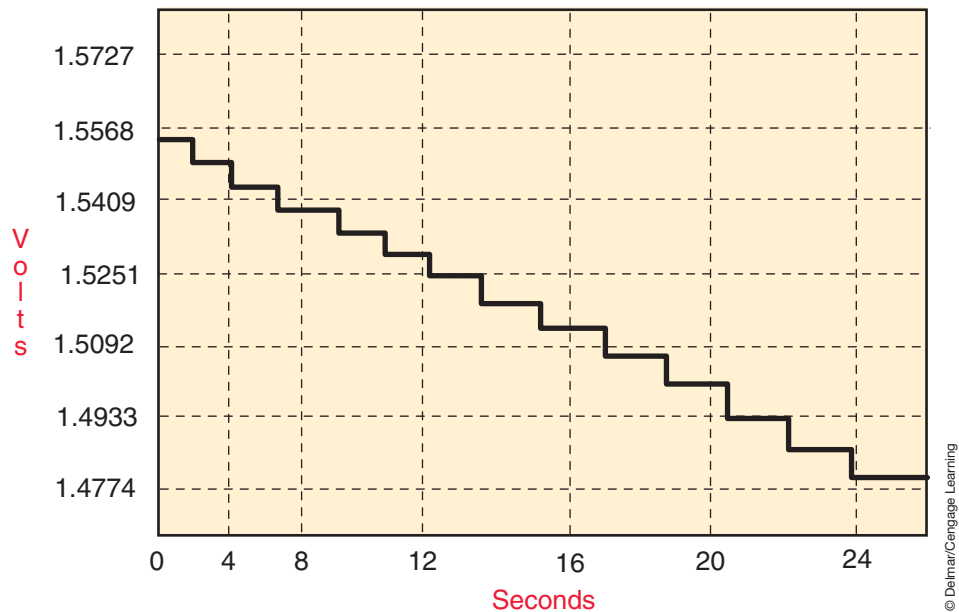


FIGURE 10-7 Normal NTC thermistor operation as temperature changes from cold to warmer.

voltage is high when the signal circuit is connected to chassis ground, the resistance is in the signal circuit. If the voltage reading is above 0 volts when the jumper wire is connected across the two terminals, the resistance is in the sensor ground circuit.

The circuits can also be tested using an ohmmeter. Disconnect the sensor and the control module connectors. Connect an ohmmeter from each sensor terminal to the control module terminal to which the wire is connected. Both sensor wires should indicate less resistance than specified by the vehicle manufacturer. If the wires have higher resistance than specified, the wires or wiring connectors must be repaired. Also, test circuits for being shorted together.

If the control module sets a rationality-type DTC for the thermistor circuit, this means the sensed value does not agree with other inputs. To test for this type of fault, allow the vehicle to **cold soak** long enough to allow all the temperature sensors to be at room temperature. Use the scan tool to compare the different temperature values for such sensors such as engine coolant temperature (ECT), intake air temperature (IAT), ambient temperature, and battery temperature. If a sensor value is different than the others, diagnose the sensor and circuit as described above.

Intermittent faults may be located by using a lab scope or the data-recording function of the scan tool. Since these instruments indicate a change in voltage over time, any change that occurs on the trace that cannot actually happen in the time frame indicates a problem with the circuit. For example, engine temperature cannot increase 80 degrees in 2 seconds. Since the ECT sensor is used by some body systems (such as air conditioning), a fault with this sensor may result in many different customer concerns being expressed. Figure 10-7 is a data recording of a normally operating ECT and Figure 10-8 is a data recording of an intermittent fault.

## Diagnosing PTC Circuit Protection Devices

The **polymer** PTC consists of a plastic with carbon grains embedded in it that has the ability to trip (increase resistance to the point it becomes the load device in the circuit) during an overcurrent condition and reset after the fault is no longer present. PTCs are rated much like a fuse; so if they experience an excessive overload, they can be damaged. When the circuit the PTC is protecting experiences a current overload, the PTC resistance increases, which reduces the amperage to a safe level. At this point, the PTC acts as the load for the circuit. Normally the PTC will not go to a complete open state during this time.

Cold soak means to allow the vehicle to sit without the engine running long enough that the coolant temperature equalizes with ambient temperature.

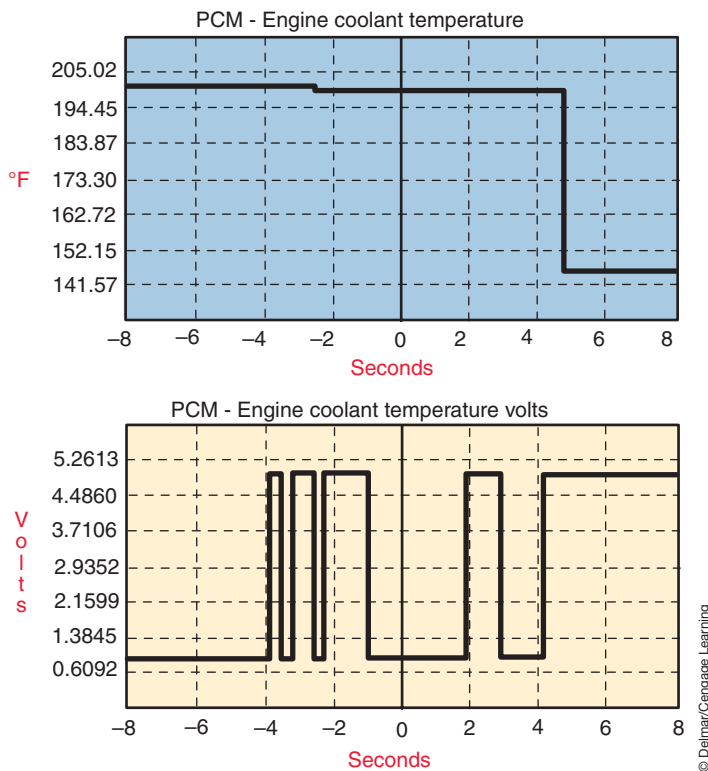
### Classroom Manual

Chapter 3, page 74



### SPECIAL TOOLS

DMM



**FIGURE 10-8** Data recording of ECT sensor circuit with intermittent fault.

Consider the circuit shown in Figure 10-9 that uses a PTC to protect the power window motor. If the motor is inoperative and a check of voltage to the motor indicates that 0 volts is present, the problem may be the PTC. Often the PTC is installed into the fuse box. In most cases they are not serviceable as separate units, but test ports are generally provided. An ohmmeter can be used to measure the resistance of the PTC. With the battery disconnected, measure the resistance across the PTC's terminals. A high or infinite reading indicates a damaged PTC. Before replacing the PTC, be sure to locate and repair the cause of the excessive current draw that damaged the first PTC.

Since disconnecting the battery to perform resistance tests with an ohmmeter results in computers resetting, loss of adaptive memories, and other set values, it is often more desirable to use a voltmeter instead. Simply measure the voltage drop between the input side of the PTC and the output side. There should be a low voltage drop across these points. Since the resistance of the PTC increases as the temperature of the circuit increases, a high voltage drop indicates the PTC resistance is increasing. This may be due to a short in the circuit; so confirm this is not the case by disconnecting in-line and component connectors while observing the voltmeter. If the voltmeter reading decreases toward 0 volts when a connector is unplugged, then there is a short in the circuit.

## DIAGNOSING PRESSURE SENSORS

Inputs used to determine pressures may be something as simple as a switch or can be a pressure transducer. This section discusses the routines used to diagnose pressure monitoring input circuits.

### Pressure Switch Diagnosis

Pressure switch circuits are simple on-/off-type switches. They can be used to control the operation of a warning lamp; for example, an oil pressure warning lamp. The pressure switch

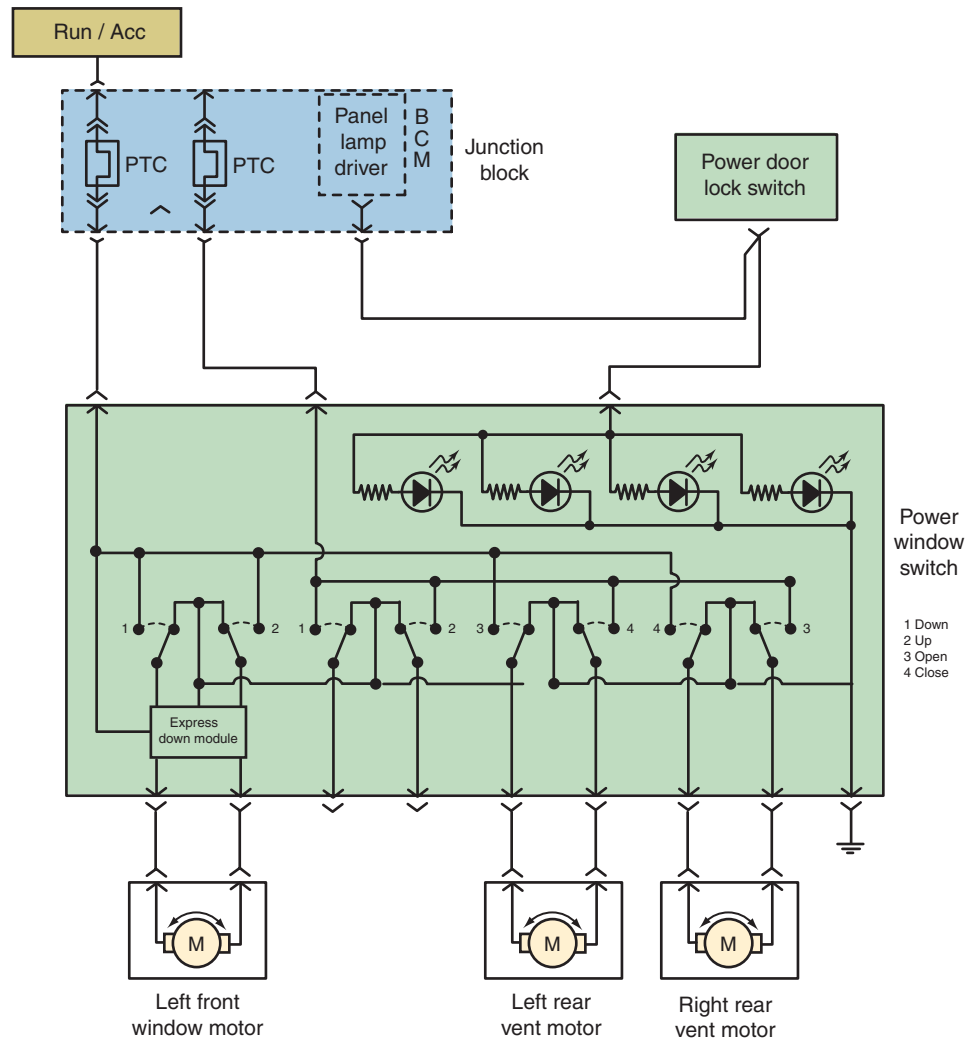


FIGURE 10-9 PTC protected circuit.

© Delmar/Cengage Learning



### SPECIAL TOOLS

- Scan tool
- DMM
- Jumper wires
- Backprobing tools

can be used to turn on and off a system. An example of this would be a high-pressure cut-off switch used in some air-conditioning systems. Also the pressure switch may be an input to a control module to indicate proper operation of the system. This is the case of a pressure switch used in the hydraulic circuits of an electronically controlled automatic transmission.

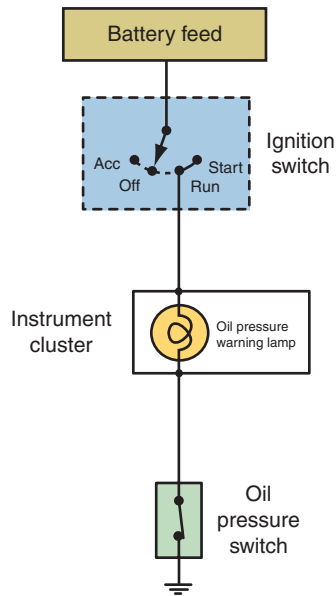
Regardless of their function, they are set to open and close at a certain pressure. Usually this is done by a calibrated spring or disc. We will first look at the process to diagnose an oil pressure warning lamp circuit.

Consider the simple circuit that is illustrated in Figure 10-10. This circuit uses a normally closed oil pressure switch that will open at a preset pressure. To test faulty warning lamp operation, first turn the ignition switch to the RUN position. The lamp should illuminate.

If the light does not come on during the prove-out, disconnect the sender switch connector (Figure 10-11). Use a jumper wire to connect the sender switch circuit from the ignition switch to ground. With the ignition switch in the RUN position, the warning lamp should light. If the light does not come on, either the bulb is burned out or the wiring is faulty. If the lamp comes on, the problem is a faulty switch or its ground.

If voltage is not present to the sending unit, the bulb may be burned out. At this point, the instrument cluster will need to be removed. With the cluster removed, check for battery voltage to the panel connector. If voltage is present, substitute a known good bulb and test again.





**FIGURE 10-10** Normally closed oil pressure switch circuit.



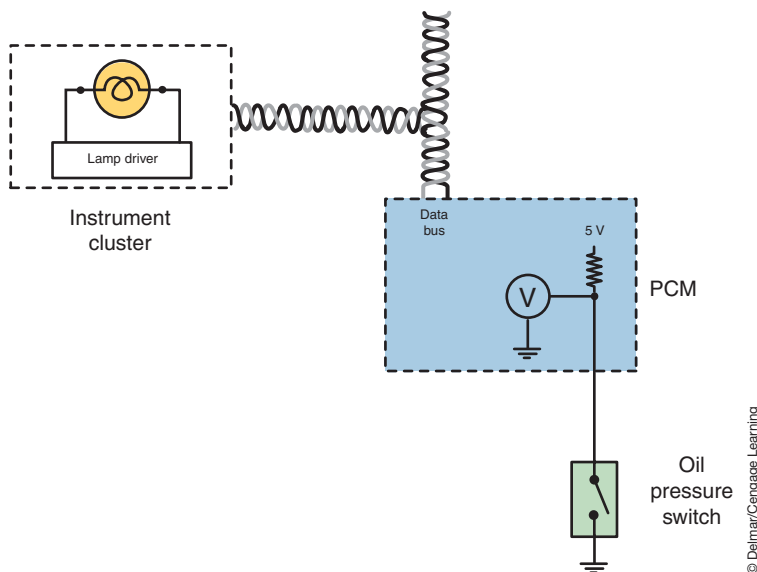
**FIGURE 10-11** Oil pressure switch and connector.

© Delmar/Cengage Learning

© Delmar/Cengage Learning

If the customer states that the warning light stays on after the engine is started, test in the following manner: Disconnect the lead to the sender switch. The light should go out with the ignition switch in the RUN position. If it does not, there is a short to ground in the wiring between the lamp and the oil pressure switch. If the light goes out, replace the oil pressure switch.

Computer-driven instrument cluster warning lamps may use normally open pressure switches that close when oil pressure increases. These systems use the switch as an input that is used to turn on or off the warning lamp; they do not directly operate the warning lamp. Consider the system illustrated in Figure 10-12. The switch is a direct input to the PCM. The PCM will send a sense voltage to the switch through a pull-up resistor. When oil pressure is below the threshold of the switch, the switch is open and the voltage sense will be high. A data bus message will be sent to the instrument cluster requesting a light on activation. When the switch closes, the sense circuit is pulled low and the light-off request is sent to the instrument cluster.



**FIGURE 10-12** Computer-controlled warning lamp systems can use the pressure switch as an input.

© Delmar/Cengage Learning

If the customer states that the oil pressure light does not go out after the engine is started, first use a shop oil pressure gauge to confirm adequate oil pressure.

**Classroom Manual**

Chapter 10, page 277

Preliminary testing of this circuit can be performed by simply unplugging the oil pressure switch. With the ignition switch in the RUN position, the lamp should be on. Unplugging the oil pressure switch should turn off the lamp. If these results are not accomplished, then the cause will need to be pin-pointed.

A scan tool accessing the instrument cluster module can be used to command activation of the lamp. If the lamp does not come on when commanded, the problem is a faulty lamp, circuit board, or instrument cluster module. If the lamp does light when commanded, the fault is in the signal to the instrument cluster. Use the scan tool to access the data stream to the instrument cluster module. Confirm that the proper message is being received.

If unplugging the oil pressure switch does not turn the warning lamp on and the data bus message seen on the scan tool confirms that the requested state is to turn the lamp off, test the circuit from the PCM to the oil pressure switch for a short to ground. Use a voltmeter to test for the proper level of sense voltage from the PCM. If the voltmeter reads 0 volts, either the circuit is shorted to ground or the PCM is faulty. The circuit is not open because the symptom is the lamp is always off. Use an ohmmeter to test for continuity between the oil pressure switch connector and engine ground. The meter should have a very high-resistance reading. If the resistance is low, the circuit is shorted to ground. Unplug the PCM connector and test again between the circuit and engine ground. If it is now reading infinite, the PCM has an internal short.

If the lamp is always on (and the data bus indicates this is the requested state of the lamp), test the sense circuit between the PCM and the oil pressure switch for an open circuit. Unplug the oil pressure switch and use a jumper wire to connect the circuit to ground. The requested lamp state displayed on the scan tool should indicate a lamp-off command. If it does, replace the oil pressure switch. If the request does not change from on to off, backprobe the PCM connector for the sense circuit and use a jumper wire to connect the circuit to ground. If the lamp request changes to off, repair the open in the circuit between the PCM and the oil pressure switch. If the requested state does not change, the PCM is faulty.



### SERVICE TIP:

If there was a circuit problem in the data bus between the PCM and the instrument cluster there would be multiple symptoms such as speedometer, tachometer, and engine temperature gauges not operating.

### Classroom Manual

Chapter 10, page 265



### SPECIAL TOOLS

Scan tool  
Vacuum gauge  
Jumper wire  
DMM

## Diagnosing Wheatstone Bridge Pressure Sensors

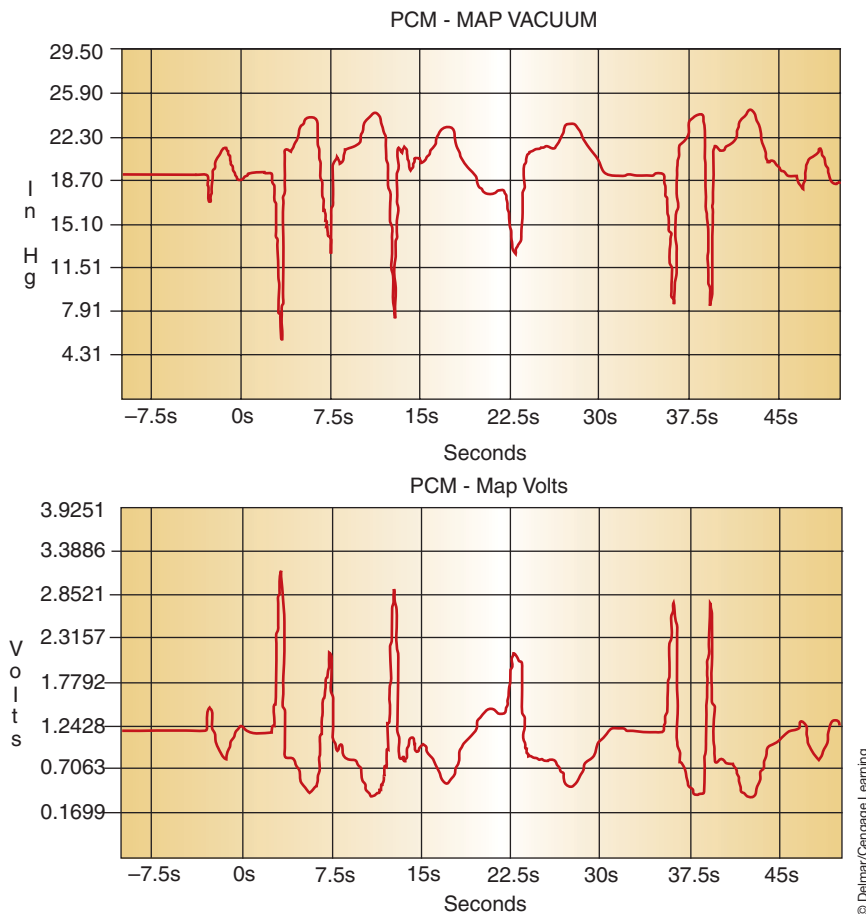
Pressure sensors are generally a form of strain gauge that determines the amount of applied pressure by measuring the strain a material experiences when subjected to the pressure. Most strain gauge pressure sensors are a form of **piezoresistive** construction. A piezoresistive sensor changes in resistance value as the pressure applied to the sensing material changes. A common piezoresistive pressure sensor is the **Wheatstone bridge**.

The Wheatstone bridge is used to measure small changes in resistance in a strain gauge. The manifold absolute pressure (MAP) sensor commonly uses the Wheatstone bridge as a sensing element. The MAP sensor is a primary sensor for determining the quantity of fuel to be injected into the combustion chamber. It is used in the process of determining the amount of air that is entering the combustion chamber at that instant in time. In most systems, it also serves as the means of determining the barometric pressure prior to starting the engine. Since the MAP sensor input indicates engine load, this information is also used by other body and chassis systems.

A defective MAP sensor may cause a rich or lean air–fuel ratio, excessive fuel consumption, and engine surging. It can also result in improper automatic transmission operation and/or improper air-conditioning system operation.

Diagnosis of MAP sensors differs between types. If the MAP sensor signal voltage is within the programmed value range of the PCM, a diagnostic trouble code (DTC) may not set. For example, an open signal circuit will set a DTC, but resistance in the circuit that causes the voltage to be off by a few millivolts may not set a fault code. Also, a vacuum leak will cause the voltage values from the signal circuit to be different from specifications.

A very simple test of the Wheatstone bridge MAP sensor is to monitor the MAP vacuum and voltage values displayed on the scan tool (Figure 10-13). With the ignition switch in the RUN position (engine off), record the MAP reading. At this time the reading will actually be



**FIGURE 10-13** Correlation between MAP vacuum and MAP volts as different loads on engine are applied.

atmospheric pressure and the voltage should confirm the reading. Compare this reading with the actual barometric pressure and the two should be equal. A MAP sensor that does not read correct barometric pressure cannot read correct vacuum. If the reading is not correct, verify the condition of all the circuits to the MAP sensor, as discussed below. If the circuits are good, replace the sensor.

If the readings are within the normal ranges, start the engine and allow it to idle. The MAP vacuum and MAP voltage should indicate correct vacuum readings. This may be confirmed by a mechanical vacuum gauge connected to a port in the intake manifold.

To perform a quick test of the circuits, consider the schematic of a Wheatstone bridge sensor circuit (Figure 10-14). If the scan tool indicates a voltage reading of 5 volts, this would be caused by an open or short to voltage in the signal circuit, an open in the return circuit, or a faulty sensor. Unplug the sensor and use a jumper wire to jump the signal circuit to ground. The scan tool should now read 0 volts. If it still reads 5 volts, the circuit is open between the control module and the sensor connector. If the voltage is above 0 volts, there is excessive resistance in the signal circuit between the control module and the sensor connector. If the reading was 0 volts, move the jumper wire to short the signal circuit to the return circuit. The scan tool should now read 0 volts in a proper operating circuit. If the scan tool displays 5 volts, the return circuit is open. If the reading is above 0 volts, there is excessive resistance in the return circuit. If all of the readings are normal, the sensor is faulty.

If the scan tool reading with the ignition in the RUN position and sensor connected was 0 volts, the problem is either an open 5-volt supply circuit or a short to ground in the signal circuit. If the voltage changes to 5 volts when the sensor is unplugged, the sensor is faulty. If the voltage remains 0 when the sensor is unplugged, use a voltmeter to check the supply circuit



### SERVICE TIP:

Anytime you are using a scan tool to monitor a pressure reading, do not accept the displayed value until you confirm the voltage. If the system is substituting a pressure value you may be fooled into thinking the sensor is operating properly. By correlating the signal voltage to the pressure reading, a fault in the circuit can be determined.

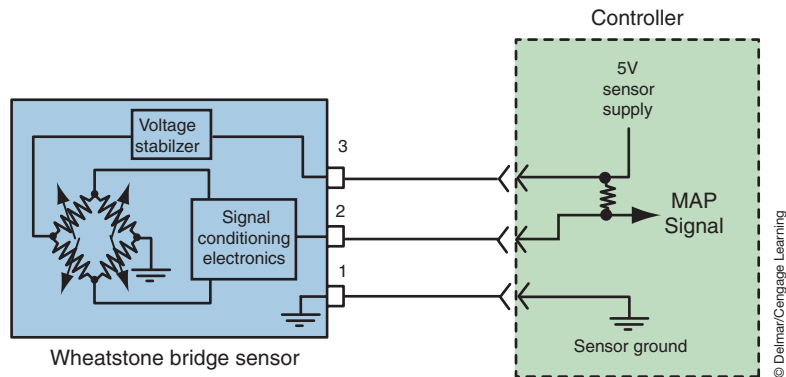


FIGURE 10-14 MAP sensor circuit.

for 5 volts. If the voltage is low, there is either high resistance, an open, or a fault in the control module. These problems can be isolated by using an ohmmeter to test the continuity of the circuit.

**DMM Testing.** To test the Wheatstone bridge sensor with a digital multimeter (DMM), backprobe the sensor signal wire and turn the ignition switch to the RUN position (engine off). Connect the DMM between the signal wire and ground. The voltage reading indicates the barometric pressure signal from the sensor to the control module. Usually this voltage is about 4.0 volts, depending on altitude. If the signal circuit voltage is not within the vehicle manufacturer's specifications compared with actual barometric pressure, confirm the sensor's voltage supply and return circuits are good. If these circuits are good, replace the sensor.

If the pressure sensor is installed into a system that is not exposed to atmospheric pressures (air-conditioning system high side pressure sensor, for example), mechanical gauges may need to be used to confirm proper voltage readings for that pressure. In some instances, it may be possible to remove the sensor from the system so it is exposed to atmospheric pressure.

If the voltage is acceptable with the ignition in the RUN position and the engine off, the next step is to confirm a change in voltage as conditions that the sensor is exposed to changes. For example, a MAP sensor is exposed to engine vacuum once the engine is started, and A/C pressure transducer is exposed to high side pressures as the A/C system cycles on and off, a boost pressure sensor is exposed to pressures greater than atmospheric as engine speed is increased. In the example of a MAP sensor, start the engine and observe the signal voltage. The voltage should have changed to a low value. If the voltage does not change, the sensor pressure chamber is obstructed or damaged and the MAP sensor requires replacement. If the voltage did change, allow the engine to warm to normal operating temperature while watching the voltage. Compare your voltage reading to specifications. If they are within specifications and the MAP sensor tests good, further testing of other components will be necessary.

For the Wheatstone bridge sensor circuit shown in Figure 10-14, if the voltage reading obtained in the initial test was 0 volts, unplug the MAP sensor connector and measure the voltage on each terminal with the ignition in the RUN position. On a three-wire connector, the voltage will usually be 5.0 volts on the supply circuit, 5.0 volts on the signal circuit, and 0 volts on the ground circuit. If these readings are obtained, the MAP sensor is suspect. If these voltages are not obtained, perform the same tests discussed as above. In this case, confirm the changes in voltages as read on the DMM. If needed, use the ohmmeter function to test for continuity between the PCM connector and the MAP connector on the suspect circuit with the ignition in the OFF position. If there is continuity in the circuit, confirm PCM powers and grounds. If these are good, replace the PCM.



## SPECIAL TOOLS

DMM  
Back probing tools

**AUTHOR'S NOTE:** Some sensor signal circuits may have 0 volts when the connector is separated. Always confirm the expected voltage values with the proper service information.

If the voltage recorded in the first step is inaccurate, backprobe the 5-volt supply circuit wire (connector plugged to the sensor) with a voltmeter with the ignition in the RUN position. If the reference wire is not supplying the specified voltage, check the voltage on this wire at the PCM connector. If the voltage is within specifications at the PCM, but low at the sensor, repair the 5-volt supply circuit wire for high resistance or an open. If this voltage is low at the control module, disconnect the control module's connector and use an ohmmeter to test for a short to ground. If there is no short to ground indicated, check the voltage supply and ground circuits for the control module. If these circuits are satisfactory, replace the control module.

If the voltage supply circuit is good, then test the sensor return (ground) circuit. With the ignition switch in the RUN position, backprobe the ground circuit terminal at the connector (with the connector plugged into the MAP sensor). Connect the voltmeter from the sensor ground wire to the battery ground. If the voltage drop across this circuit exceeds specifications, test the voltage drop on the PCM's ground circuits. If this is good, repair the ground wire from the MAP sensor to the control module.

## Capacitance Discharge Sensor Diagnostics

Another variation of the piezo sensor uses capacitance discharge. Instead of using a silicon diaphragm, the **capacitance discharge sensor** uses a variable capacitor. Some of these sensors will use the discharged voltage as the signal and will be diagnosed in the same manner as the Wheatstone bridge sensor. Other type of capacitance discharge sensors produce a digital voltage signal of varying frequency. On these types of sensors a voltmeter can be used to check the 5-volt reference and the ground circuits. However, to test the signal circuit of this type of sensor requires the use of a sensor tester that changes the sensor varying frequency to a voltage reading or a scan tool that performs this function. Photo Sequence 19 illustrates the use of the special sensor tester to diagnose the frequency-generating MAP sensor.

If the special sensor tester is not available, diagnosis can be performed using a DMM that has a frequency measurement function. For example, to test a sensor used to measure vacuum, connect the positive meter lead to the sensor signal wire and the negative lead to ground. Set the meter to read hertz with a + trigger. With the ignition in the RUN position, measure the frequency on the sensor signal wire with no vacuum applied. Using a hand vacuum pump, increase the vacuum against the sensor in 5-inch Hg increments. Record the hertz reading at each step. Figure 10-15 is an example of expected test results for a good sensor. Be sure to refer to the correct service information for the sensor you are testing. In this example, the hertz readings decreases as vacuum is applied.

Vacuum Applied	Output Frequency
0 in. Hg	152–155 Hz
5 in. Hg	138–140 Hz
10 in. Hg	124–127 Hz
15 in. Hg	111–114 Hz
20 in. Hg	93–98 Hz

© Delmar/Cengage Learning

**FIGURE 10-15** Examples of MAP sensor frequency with various vacuum values.

### Classroom Manual

Chapter 10, page 268



### SPECIAL TOOLS

- DMM
- MAP sensor tester
- Scan tool
- Hand vacuum pump
- Backprobing tools



### CAUTION:

Connecting any type of voltmeter directly to the voltage signal wire on a Ford MAP sensor will cause damage to the sensor.



# PHOTO SEQUENCE 19

## TYPICAL PROCEDURE FOR TESTING FREQUENCY-GENERATING SENSORS

All photos in this sequence are © Delmar/Cengage Learning.



**P19-1** Remove the MAP sensor connector and vacuum hose.



**P19-2** Connect the MAP sensor tester leads to the MAP sensor.



**P19-3** Connect the MAP sensor connector to the harness connector.



**P19-4** Connect the MAP sensor tester to the DVOM.



**P19-5** With the DVOM set to DC voltage, observe the MAP sensor barometric pressure (BARO) reading on the voltmeter and compare this reading to specifications.



**P19-6** Connect a hand vacuum pump to the MAP sensor and supply 5 in. Hg. Observe the MAP sensor reading and compare to specifications.



**P19-7** Increase the vacuum applied to the MAP sensor to 10 in. Hg and observe the reading. Compare this reading to specifications.



**P19-8** Apply 15 in. Hg to the MAP sensor and compare the reading to specifications.



**P19-9** Increase the vacuum 20 in. Hg to the MAP sensor and compare the reading to specifications. If any of the MAP sensor readings do not meet specifications, replace the MAP sensor.



# Lab Scope Testing of the Pressure Sensor

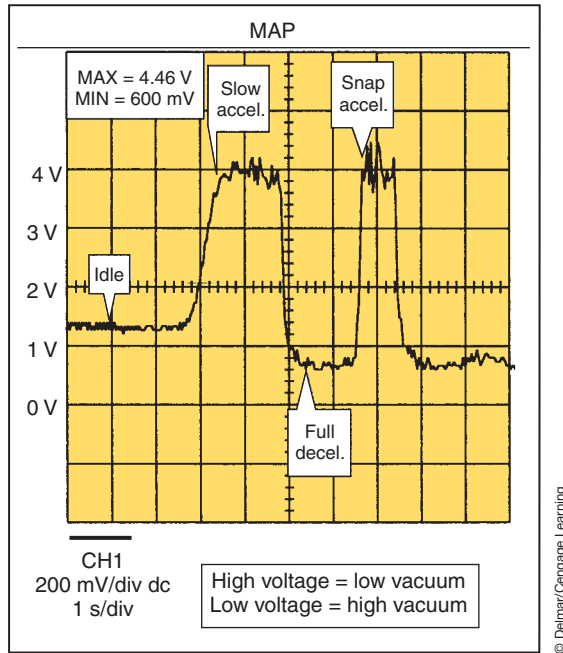
A good method of testing the pressure sensor is to use a lab scope. As the exposed pressures change, the sensor voltage signal should increase and decrease (Figure 10-16). Lack of change, a slow response, or an erratic signal may be the result of the sensor or connecting wires being defective.

A frequency-generating sensor produces a frequency that should change as the exposed pressures change. The upper voltage value of the trace should be 5 volts, while the lower voltage should be close to zero (Figure 10-17). If the frequency is erratic or does not change or the voltage values are incorrect, the sensor is defective.

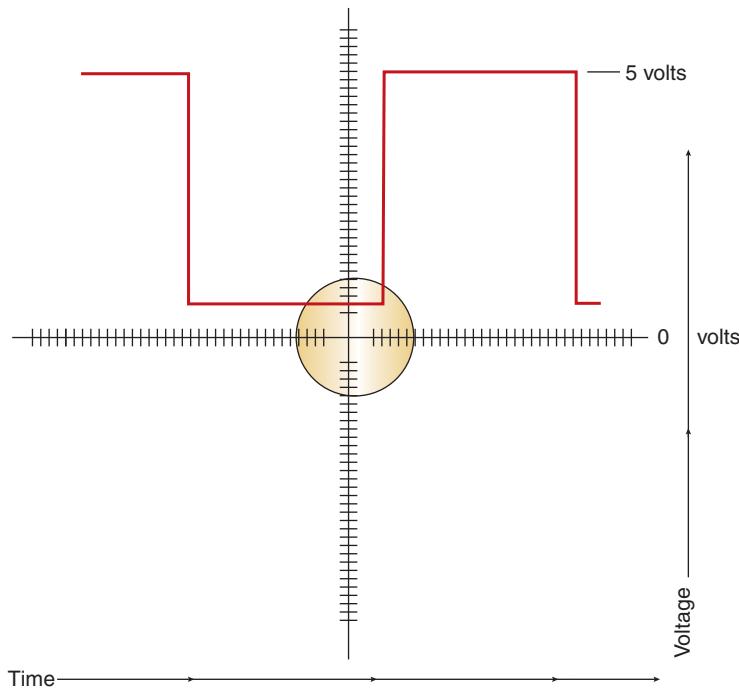


## SPECIAL TOOLS

Lab scope  
Backprobing tools



**FIGURE 10-16 :** Lab scope trace of normal MAP sensor operation.



**FIGURE 10-17** Example of frequency output of capacitance-type sensor.



### SPECIAL TOOLS

- DMM
- Backprobing tools
- Lab scope
- Scan tool

The knock sensor is also referred to as the detonation sensor.

Knock is the spontaneous auto-ignition of the remaining fuel/air mixture in the engine combustion chamber that occurs after normal combustion has started causing the formation of standing ultrasonic waves.

## Diagnosing Piezoelectric Transducers

**Piezoelectric sensors** produce a proportional voltage output resulting from deformation of the element as pressure is applied. Since the **piezoelectric transducer** is capable of measuring the pressures associated with ultrasonic waves, it can be used for many functions, including that of a **knock sensor**. The knock sensor measures engine knock, or vibration, and converts the vibration into a voltage signal. Piezoelectric sensors are also used in passive restrain systems.

We will consider the knock sensor in this example since it is one of the easiest piezoelectric-type sensor to understand and test. Diagnosing of other piezoelectric sensors will be covered during the discussions on system diagnosis in later chapters.

Knock is caused by excessive spark advance for the given engine-operating conditions. The output voltage from the knock circuit represents the strength of the engine knock and is read by the PCM. The knock sensor is constantly producing an output voltage due to engine background noise, even when knock is not present (Figure 10-18). If knock occurs, the voltage output will increase (Figure 10-19). At this threshold, knock has occurred and the PCM

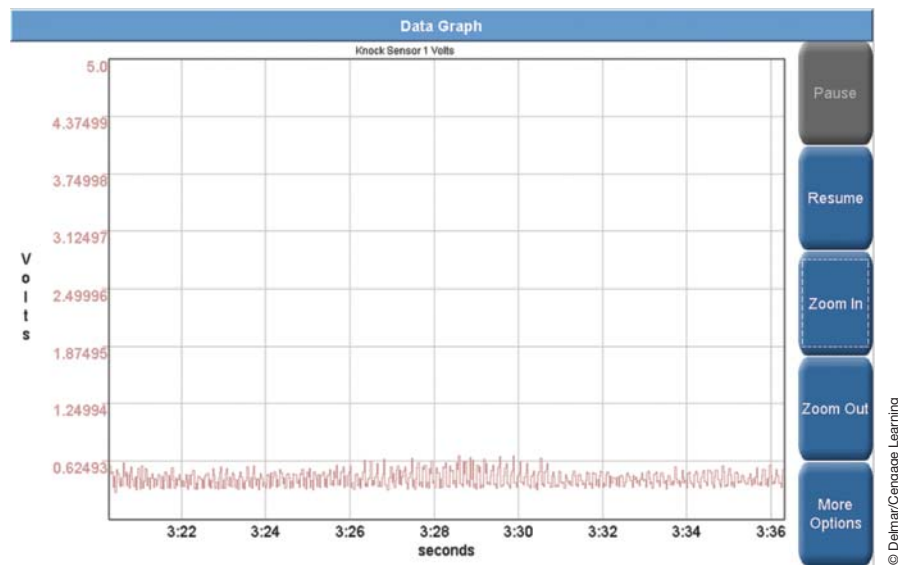


FIGURE 10-18 Normal knock sensor activity at idle.

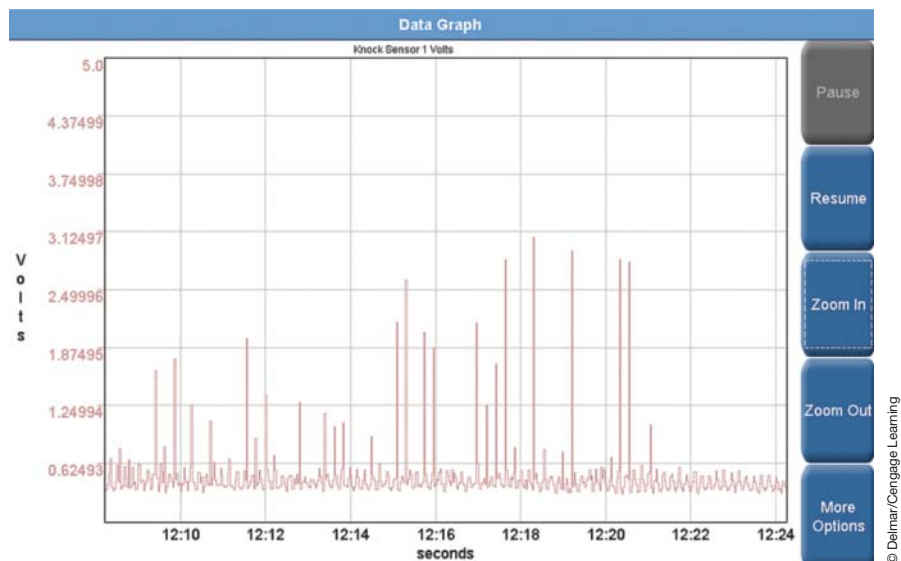


FIGURE 10-19 Knock sensor activity when knock is occurring.

calculates the necessary amount of short-term spark retard required to be subtracted from the spark advance based on the severity of the knock event. Severity is determined by the amount of knock voltage that is greater than the knock threshold voltage level.

The procedure for checking a knock sensor varies depending upon the vehicle make and year. Always follow the vehicle manufacturer's recommended test procedure and specifications. Some knock sensor circuits use a single wire and the sensor case to engine connection as ground. If there are two wires in the circuit, one is the signal circuit and the other is ground. Follow these steps for a typical knock sensor diagnosis:

1. Disconnect the knock sensor wiring connector, and turn on the ignition switch.
2. Connect a voltmeter from the disconnected knock sensor signal circuit to ground. The voltage should be 4 V to 6 V. If the voltage is within specifications, the ground circuit should be tested as in step 3. If the voltage is about 12 volts, the circuit is shorted to a power circuit. If the specified voltage is not available at this signal circuit, backprobe the knock sensor wire at the PCM (or use a breakout box) and read the voltage at this terminal. If the voltage is satisfactory at this terminal, repair the knock sensor signal circuit for an open. If the voltage is not within specifications at the PCM terminal, replace the PCM.
3. If the voltage at the signal circuit connection to the sensor is within specifications, move the negative voltmeter lead to the ground circuit terminal of the sensor connector. If there is no voltage reading, the ground circuit is open. If the voltage reading is lower now than in the initial test, check for high resistance in the circuit.
4. If the above tests indicate there is not a problem with the signal or the ground circuits, then test the knock sensor. Use an ohmmeter connected between the knock sensor signal terminal and the ground terminal. If the knock sensor uses only one wire, the ground terminal is the case. Compare the ohmmeter reading with specifications, usually between 3,300 and 4,500 ohms. If the knock sensor does not have the specified resistance, replace the sensor.

Operation of the knock sensor can be observed with a lab scope. Some scan tools may also provide a graphed data display or recorded event display. As discussed, the sensor is active at idle but when knock is occurring the sensor should show increased voltage output.

## DIAGNOSING POSITION AND MOTION DETECTION SENSORS

Input data concerning position, motion, and speed are needed for many automotive systems such as electronic vehicle stability control, antilock brakes, air bags, and roll-over mitigation. Today's technician will be called upon to diagnose these sensors. A common type of sensor to determine position and motion is the potentiometer. Motion and speed sensors that use magnetism include MR, inductive, variable reluctance (VR), and Hall-effect sensors. In addition, photoelectric sensors, solid state accelerometers, axis rotation sensors, yaw sensors, and roll sensors are common components on many systems. This chapter will explore the diagnostics involved to properly determine operation of these types of sensors.

### Testing the Potentiometer

A **potentiometer** sensor can be used to measure linear or rotary movement. These sensors are tested by measuring the input voltage to the sensor and the feedback voltage to the computer. The feedback voltage to the computer should change smoothly as the resistance value of the sensor changes. To test these voltage signals, a series of jumper wires may be required (Figure 10-20). The jumper wires provide a method of gaining access to the terminals of weather-pack connectors without breaking the wire insulation.

An ohmmeter can be used to measure changes in resistor values as the wiper is moved across the internal fixed resistor. Disconnect the sensor from the system. Connect the ohmmeter leads to the reference and ground terminals (Figure 10-21). This measures the value of the fixed resistor. Check the results against specifications. If good, connect the ohmmeter

**Classroom  
Manual**

Chapter 10, page 268



### SPECIAL TOOLS

DMM  
Lab scope  
Jumper wires



### CAUTION:

Do not use a test light to test for voltage. This may damage the system. Also, do not probe for voltage by sticking the wire insulation.



### SPECIAL TOOLS

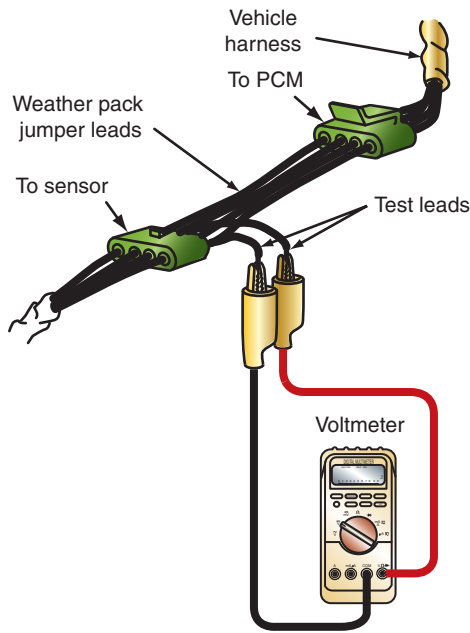
DVOM  
Lab scope

The order of diagnostic testing is not set in stone. The presentation given is an example of testing that can be done on the **throttle position sensor** (TPS) circuit to locate the fault. Not all of the tests will need to be done to isolate the problem.



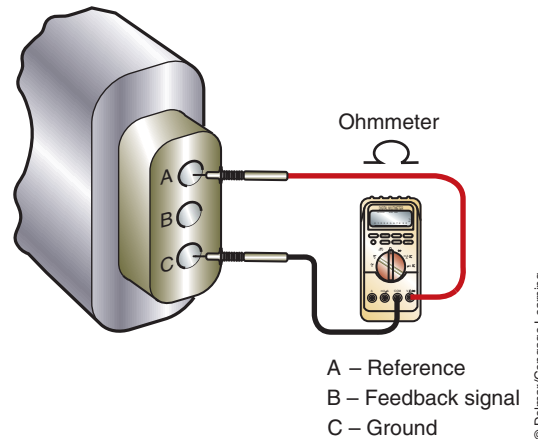
### SERVICE TIP:

While the potentiometer is being moved through its travel and while observing the sensor voltage signal, tap the sensor lightly and watch for fluctuations on the voltmeter reading. Fluctuations indicate a defective sensor.



**FIGURE 10-20** A jumper harness connected between the sensor and the wiring harness allows the technician to probe for voltage or test resistance without damaging the wiring.

© Delmar/Cengage Learning



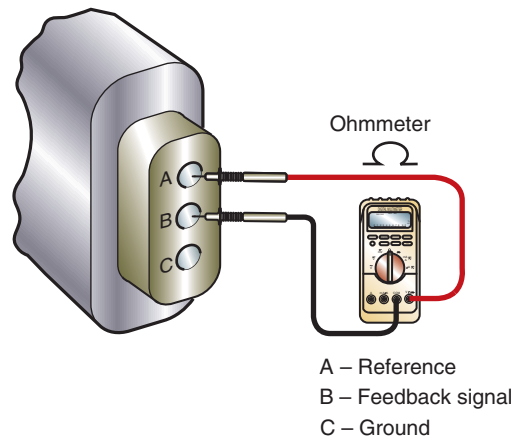
**FIGURE 10-21** Connecting an ohmmeter to test the potentiometer. This will give the fixed resistance value.

© Delmar/Cengage Learning

test leads between the reference terminal and the feedback terminal (Figure 10-22). Move the sensor's measurement arm or lever and observe the ohmmeter. The resistance should change smoothly and consistently as the wiper position is changed.

To illustrate a typical test procedure for a three-wire potentiometer circuit (Figure 10-23), begin by disconnecting the sensor connector and measure the voltage on the three terminals with the ignition in the RUN position. Compare the results with specifications since some systems will have 5 volts, 5 volts, 0 volts on the terminals (terminal A to terminal C) while others will have 5 volts, 0 volts, 0 volts. If these voltages are within specifications, reconnect the sensor and backprobe the signal wire from the sensor.

With the ignition switch in the RUN position, connect a voltmeter between the signal wire and ground. Typical voltage readings are 0.5 volt to 1 volt, with the potentiometer in the "at home position." Always refer to the vehicle manufacturer's specifications. As the potentiometer wiper is slowly moved, observe the voltmeter reading. It should climb smoothly to the maximum



**FIGURE 10-22** Ohmmeter connection to test the wiper movement. As the wiper is moved from one end to the other, the resistance should change smoothly.

© Delmar/Cengage Learning

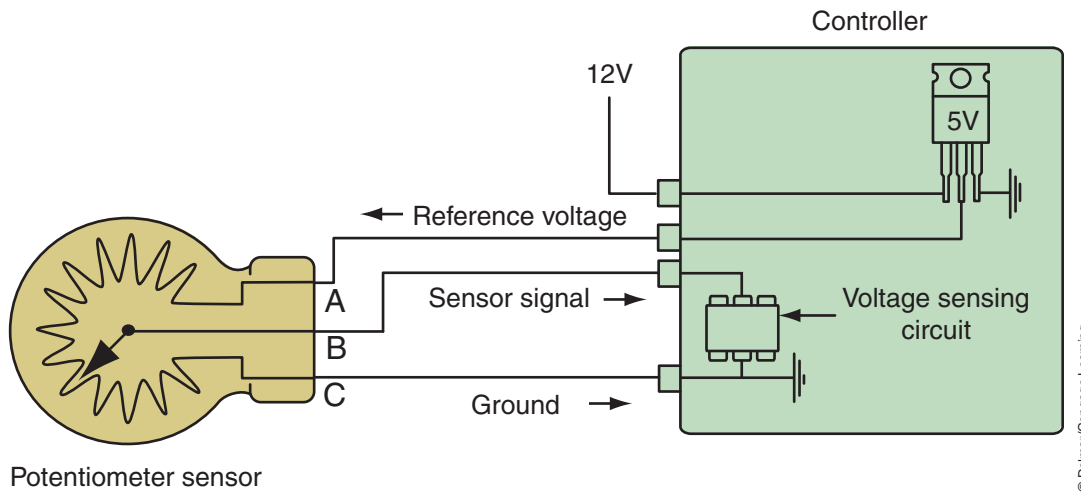


FIGURE 10-23 Potentiometer sensor circuit.

specified voltage. Typical maximum voltage is between 3.5 to 4.5 volts. If the potentiometer does not have the specified voltage or if the voltage signal is erratic, replace the sensor.

To test the sensor ground (return) circuit, do a voltage drop test. With the ignition switch in the RUN position, connect the voltmeter between the sensor ground wire at the sensor's harness connector and the battery ground. If the voltage drop across this circuit exceeds specifications (and the control module ground circuit is good), repair the ground wire from the sensor to the control module.

The lab scope is an excellent tool for testing the potentiometer since it displays every voltage value it sees. This means there is less chance of missing something while trying to use a voltmeter or an ohmmeter. Each time the wiper is moved across the fixed resistor, the sensor should provide a smooth analog voltage signal (Figure 10-24). If the sensor is defective, glitches will appear in the sensor signal as the wiper is moved (Figure 10-25). Depending on circuit design, the glitch for an open can go either upward or downward. A glitch for a short will always go downward.

When looking at the scope trace, remember you are looking at voltage over time. Evaluate the trace, asking yourself if what you see could actually occur with a good sensor. For example,

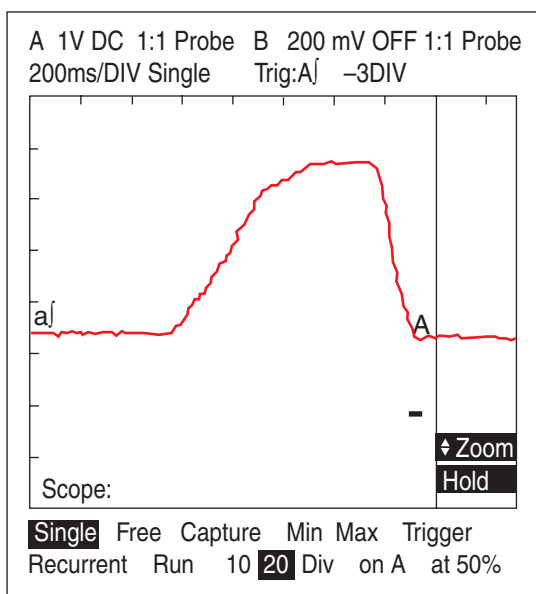


FIGURE 10-24 Normal TPS scope pattern as it is opened and closed again.

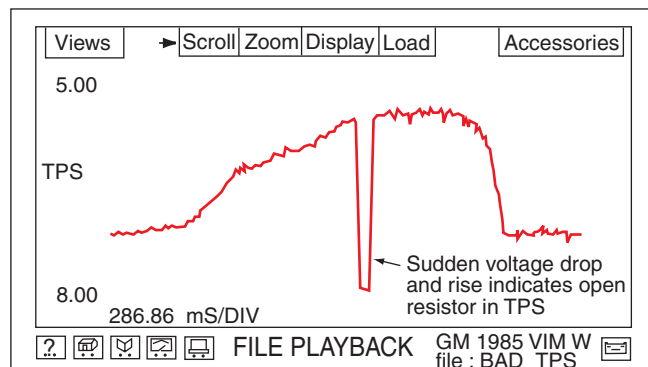


FIGURE 10-25 Faulty TPS waveform.

when the potentiometer is moved from one extreme position to the other, there should still be a ramping of the voltages involved. As the voltage moves from low to high and back again there should also be a “rounded corner” indicated on the trace. If the trace spikes straight up or down, this would indicate a problem with the sensor or circuit.

## Classroom Manual

Chapter 10, page 269



### SPECIAL TOOLS

DMM



### SERVICE TIP:

In the case of the wheel speed sensor used on many antilock brake systems (ABS), the air gap can be altered by loose wheel bearings or worn parts.

## Diagnosing Magnetic Induction Sensors

**Magnetic induction sensors** use the principle of inducing a voltage into a winding by use of a moving magnetic field (Figure 10-26). These sensors are commonly used to send data to the control module about the speed or position of the monitored component. For example, vehicle speed or wheel speed sensors can be of this design.

Improper timing pickup or rotational speed signals can be the result of circuit resistance. The zero cross characteristics of the magnetic induction sensor will accurately provide a timing reference provided that the target tooth width is close to the diameter of the sensor pole piece. However, for the ideal timing signal to occur at the zero cross is only possible if there is no electrical load on the sensor. A resistance load in the circuit will cause the inductance of the sensor coil to have a current that lags the open circuit generator voltage. This causes a phase shift in the output voltage.

Another factor that may result in improper operation of the sensor is improper tooth gap. The amplitude of the signal is directly related to the distance between the sensor coil and the toothed ring. The distance is referred to as the **air gap**. The space of the air gap is more critical at lower tone wheel speeds. Improper air gap can cause **sensor dropout**. This can occur when the sensor will not produce an output voltage at slower speeds.

**AUTHOR’S NOTE:** On some vehicles that use the ABS wheel speed sensors as an input to the speedometer, a customer may complain that the speedometer drops off if they are moving at about 10 mph. This can be caused by sensor dropout due to an excessive air gap.

To test the magnetic induction sensor, first check the resistance value of the coil. This will indicate if the coil is intact, open, or shorted. Disconnect the sensor from the system and use an ohmmeter to test the resistance value of the coil. Connect the ohmmeter across the coil terminals and record the reading. Compare the results with specifications. A lower than specified reading indicates a shorted winding. A higher than specified reading indicates resistance or an open.

The voltage generation of the sensor can be tested by connecting a voltmeter across the sensor terminals. The voltmeter must be in the AC position and on the lowest scale. Rotate the shaft while observing the voltage signal. It should increase and decrease with changes in shaft speed. Also, the frequency function of the DMM can be used to monitor the sensor output.

Magnetic induction sensors can also be tested with a lab scope. Connect the lab scope leads across the sensor’s terminals and rotate the shaft. The expected pattern is an AC signal that should be a perfect sine wave when the speed is constant (Figure 10-27). When the speed is changing, the AC signal should change in amplitude and frequency.

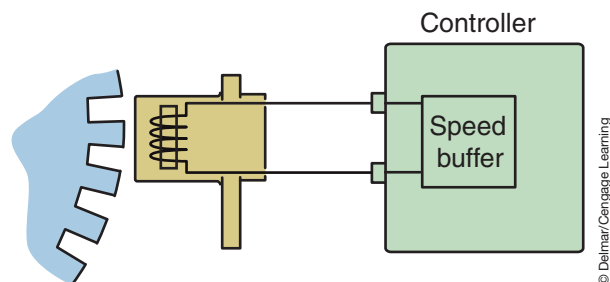
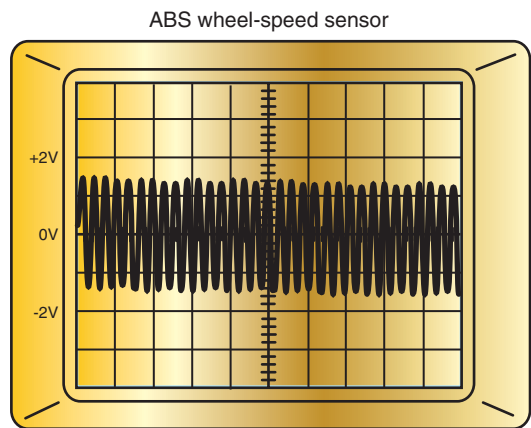


FIGURE 10-26 Magnetic inductive speed sensor circuit.





Channel 1  
1 V/div ac  
10 ms/div

Amplitude and frequency increase with wheel speed

#### Vehicle information

Test part: Wheel-speed sensor

Comment: Logged while driving 20 Mph

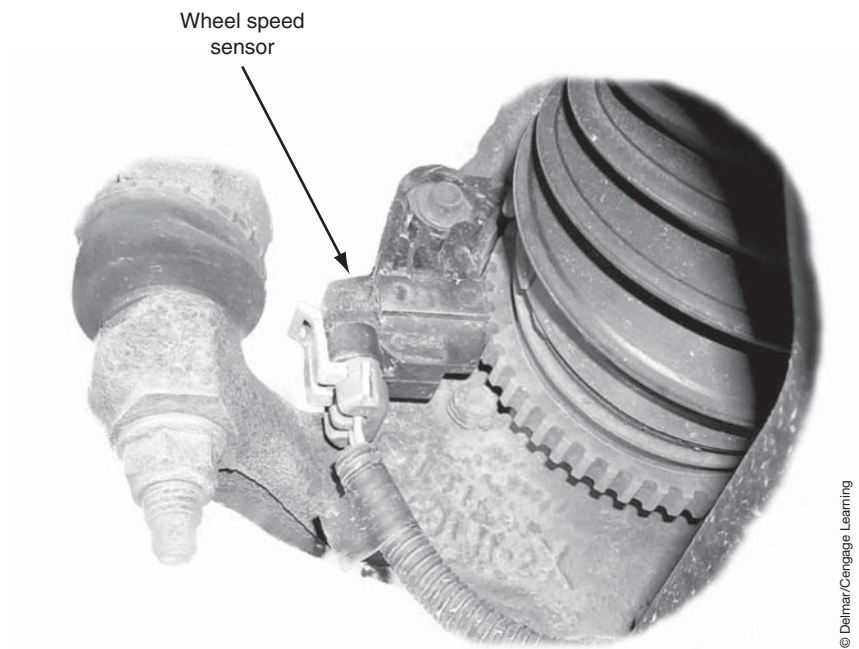
Status: KOBD (Key on driven)

Frequency: 416 Hz.

Operating temperature: Normal

© Delmar/Cengage Learning

**FIGURE 10-27** WSS waveform pattern.



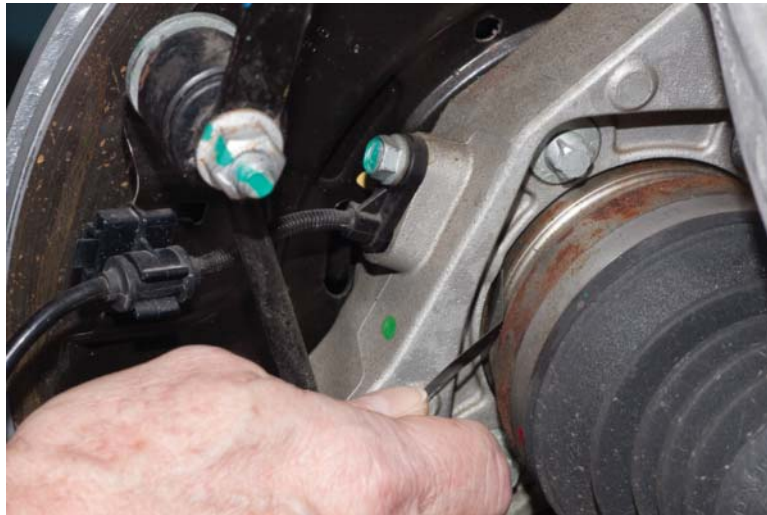
**FIGURE 10-28** Inspect the tone wheel for damage.

© Delmar/Cengage Learning

Regardless of the instrument used, you need to look for intermittent drop out, erratic frequency changes, and unstable readings. If the signal output indicates a potential problem, be sure to inspect the tone wheel (Figure 10-28) and check and adjust the air gap before condemning the sensor (Figure 10-29).

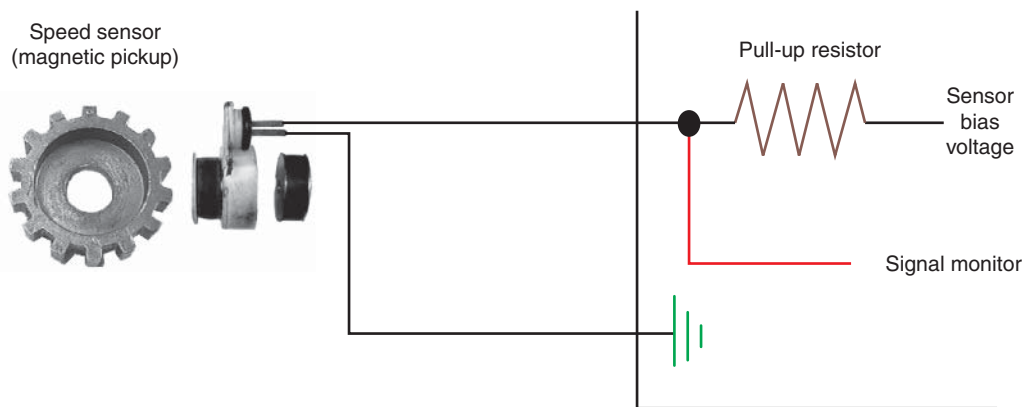
If the sensor performs properly, test the circuits between the computer and the sensor. This can be done by disconnecting both harness connectors and using an ohmmeter to check the integrity of the circuit. Check for opens and shorts to ground in both circuits. Also, test for the two circuits being shorted together. Another method is to reconnect the sensor and backprobe the harness connector at the computer and retest at this location. If there is a problem with the signal output now, the circuit wires are at fault.

A scan tool can also be used to monitor the sensor output. Usually the scan tool will display the data as rpms or miles per hour. In order to accurately determine a sensor that is putting out the wrong signal, you must have a base to measure from. For example, on an ABS system you can compare all four wheel sensor inputs to see if they all read the same value.



© Delmar/Cengage Learning

**FIGURE 10-29** Measuring the air gap.



© Delmar/Cengage Learning

**FIGURE 10-30** A speed sensor circuit that biases the signal circuit.

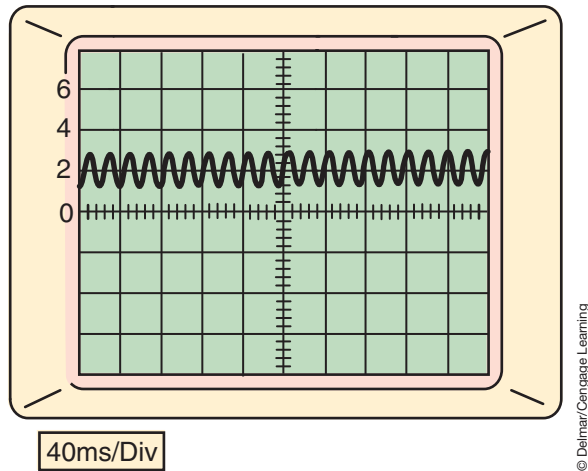
On a transmission input speed sensor, it should read the same speed as the engine crankshaft speed sensor when the torque converter is locked. The transmission output speed will need to be calculated using the input speed and the current gear ratio.

Some magnetic induction sensor circuits use a bias voltage supplied from the system's computer for use in fault detection (Figure 10-30). In addition, the bias voltage also elevates the sensor signal off the common ground plane of the vehicle electrical system to reduce signal interference. The bias voltage varies from manufacturer to manufacturer. Typically it is 5 volts; however, some manufacturers use a bias voltage of 1.5, 1.8, or 2.29 volts. Figure (10-31) illustrates a signal voltage from a system that biases the voltage to 2.29 volts. Notice that the sensor voltage signal is shifted to the positive. Always refer to the manufacturer's specifications to determine the required bias voltage when troubleshooting a magnetic induction sensor circuit.

The computer monitors the sensor signal at a point between the fixed pull-up resistor and the pickup coil. When power is applied to the circuit, current flows through the pull-up resistor and through the pickup coil to ground. The voltage drop at the signal monitor point is a predetermined portion of the reference voltage and a known value that is part of the computer program.

If an open circuit exists, no current flows through the circuit and no voltage is dropped across the pull-up resistor. The signal monitor voltage will be high. In this case, the computer will immediately set a trouble code for an open circuit fault.

If a shorted circuit exists, all or nearly all of the bias voltage is dropped across the pull-up resistor. The signal monitor voltage will be lower than the programmed signal monitor voltage.

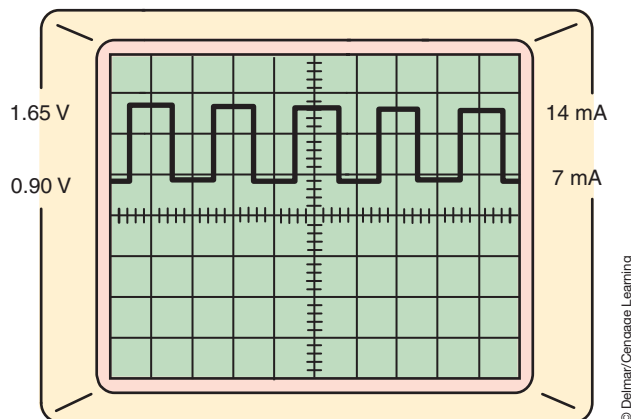


**FIGURE 10-31** Output of a biased speed sensor. Notice the voltage is above 0 volts.

The simple voltage divider circuit shown in Figure 10-30 allows the computer to detect an electrical fault as soon as the ignition is turned on. The shaft does not need to be rotating to detect these types of circuit defects. You can verify an open or short circuit fault by connecting a voltmeter between the high-voltage side of the pickup coil circuit and ground. Depending on the circuit fault, the meter should read close to full bias voltage or close to zero volts with the ignition on.

### Diagnosing the Magneto-resistive Sensor

**Magneto-resistive (MR) sensors** do not generate their own signal voltage and require an external power source. The MR bridge changes resistance due to the relationship of the tone wheel and magnetic field surrounding the sensor. The integrated circuit (IC) in the sensor is powered by a 12-volt circuit that is sent by the computer. The IC supplies a constant 7 mA power supply to the computer. The relationship of the tooth on the tone wheel to the permanent magnet in the sensor signals the IC to enable a second 7 mA power supply. The output of the sensor, sent to the computer, is a DC voltage signal with changing voltage and current levels. When a valley of the tone wheel is aligned with the sensor, the voltage signal is approximately 0.8 volts and a constant 7 mA current is sent to the computer. As the tone wheel rotates, the tooth shifts the magnetic field and the IC enables a second 7 mA current source. The computer senses a voltage signal of approximately 1.6 volts and 14 mA (Figure 10-32). The computer measures the amperage of the digital signal and interrupts the signal as component speed.



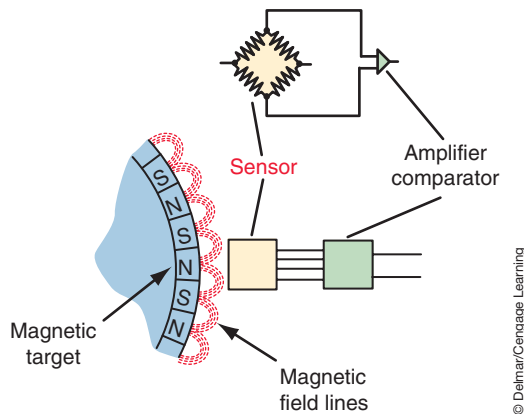
**FIGURE 10-32** Output waveform of the magneto-resistive sensor.

**Classroom Manual**  
Chapter 10, page 271



#### SPECIAL TOOLS

- Scan tool
- DMM
- Lab scope
- 12-Volt test light
- Jumper wires



**FIGURE 10-33** Active target with alternating magnetic poles.

© Delmar/Cengage Learning

Like the magnetic induction sensor, the air gap is an important factor in sensor operation. If the air gap is too wide, the current change in the circuit will cease to vary between 7 mA and 14 mA and will remain constant at one of these values. The sensor signal decreases as the air gap increases and will become too small to be recognized by the signal conditioning electronics in the computer.

The following describes the procedure for diagnosing the MR sensor that uses active target tone wheels that have alternating magnetic poles (Figure 10-33). This type of sensor is common in ABS.

If there is an active ABS fault code for a wheel speed sensor, visually inspect the wheel speed sensors, related wiring and electrical connections, and the ABS controller for obvious problems. If no problem was found, carefully backprobe the WSS harness connector and use the DMM to test for voltages on the supply circuit. With the ignition switch in the RUN position, the DMM should read above 10 volts. If the voltage is below 10 volts, check the circuit for a short to ground, high resistance, or an open.

To test for a short to ground, disconnect the WSS harness connector and the control module connector. Be sure the ignition is in the OFF position prior to disconnecting the components. Use a 12-volt test light connected to the positive post of the battery and probe the supply circuit at the WSS connector with the light. If the light illuminates, the circuit is shorted to ground.

Use the ohmmeter function of the DMM to test the supply circuit for an open or high resistance. Another method to test the supply circuit for an open is to connect a jumper wire between ground and the WSS supply circuit at the control module harness connector. Use a test light connected to a 12-volt source and probe the supply circuit at the WSS harness connector. If the light illuminates, test the power and ground circuit of the controller. If these are good, repair or replace the controller. If the light does not illuminate, the circuit is open.

If the supply circuit has greater than 10 volts, move the voltmeter test lead to measure the voltage on the signal circuit. The voltage here should be approximately 0.8 or 1.6 volts, depending on the position of the tone wheel. If the voltage reading is too high, test the circuit for a short to voltage condition. It is possible that the supply and the signal circuits are shorted together.

If zero volts are read during this test, test the circuit for a short to ground in the same manner as discussed for testing for short to ground in the supply circuit.

The signal circuit can be tested for an open condition by disconnecting the harness connector at the control module and connecting a jumper wire between ground and the signal circuit. Using a 12-volt test light connected to a 12-volt source, probe the signal circuit at the WSS harness connector. If the light does not illuminate, the circuit is open.

WSS operation can be verified by slowly rotating the wheel by hand while monitoring the voltage displayed on the DMM. This is done with the test lead still connected to the signal circuit. The sensor signal voltage should alternate between about 0.8 and 1.6 volts.

To test the circuit with a lab scope, connect the leads as you would for a voltmeter. Adjust the scope settings to read 0.5 volt divisions at a rate of about 20 ms. A good WSS scope waveform should have sharp square corners on the DC signal circuit to the control module (Figure 10-34).

A scan tool can be used to monitor the WSS inputs for comparative reasons (Figure 10-35). While the vehicle is being accelerated in a straight line, monitor the sensors while looking for an indication of one dropping out or reading different than the others. Although this identifies that there is a problem, you will still need to use the DMM or lab scope to isolate the root cause.



**SERVICE TIP:** Erratic signal outputs can be caused by damage, missing teeth, cracks, corrosion, or looseness of the tone wheel. Also, wheel bearing failure can cause the WSS signal to be erratic.

**CUSTOMER CARE TIP:** Uneven tire air pressures can cause the WSSs to read different speeds from each wheel position. This may cause the vehicle to enter ABS mode when not needed or cause the control module to set a DTC and inhibit ABS operation. Let your customers know that proper tire pressure maintenance is important for proper ABS operation.

### Alternate Magneto-resistive Sensor Diagnosis

An additional method for testing MR sensors is to design a tool that will visually display if the sensor is operating (Figure 10-36). The tool is assembled using a 9-volt battery,

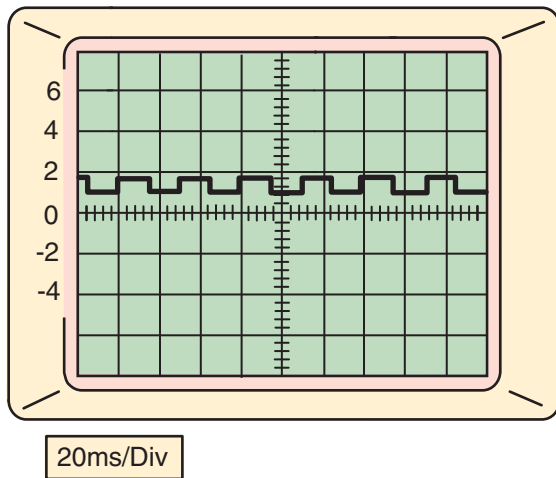


FIGURE 10-34 Active target speed sensor output.

© Delmar/Cengage Learning

Data Display - ABS			
	Name	Value	Unit
▲	LF Wheel Speed	31.73	MPH
	RF Wheel Speed	31.89	MPH
	LR Wheel Speed	31.89	MPH
	RR Wheel Speed	31.89	MPH
	ABS Pump Feed	SNA/Not Programmed	Volts
	Valve Feed	10.0	Volts
	Brake Switch Status	Not Pressed	
	Steering Angle Sensor Position	-92.96875	Degrees
	Yaw Sensor	0.0	Degrees/sec
	Pressure Sensor	16.24	psi
	Lateral Acceleration	0.02	G
▼	Rolls Complete	True	

FIGURE 10-35 The wheel speed sensor output can be read by a scan tool.

© Delmar/Cengage Learning

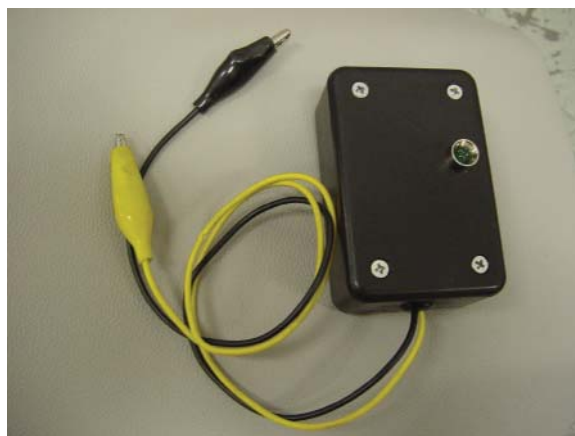


FIGURE 10-36 Special tool can be constructed to test the active speed sensor.

© Delmar/Cengage Learning



220-ohm resistor, and a LED. Construction of this tool is performed in Job Sheet 30. The tool is connected to the sensor harness connector so that the positive side of the 9-volt battery is connected to the voltage input wire of the WSS. The signal side of the sensor is connected to the 220-ohm resistor, a LED, and the negative post of the 9-volt battery. As the tone wheel is rotated, the changes in the magnetic poles will cause the LED to blink if the WSS is operating properly.

## Classroom Manual

Chapter 10, page 273



### SPECIAL TOOLS

Lab scope  
DMM



### SERVICE TIP:

In many systems that use a Hall-effect sensor, it is possible to test the sensor by use of a scratch test. For example, if the fuel/ignition system uses a Hall-effect crankshaft sensor, disconnect the sensor connector and use a terminal probe and a jumper wire to momentarily ground the signal wire back to the PCM. If the circuit is good, the PCM should respond by activating the fuel pump and/or the shutdown relays. If the PCM responds now, the problem is the Hall-effect sensor.

## Testing Hall-Effect Sensors

The best way to test the performance of Hall-effect inputs is to use a lab scope. A DMM can be used to confirm that the proper voltages and grounds are supplied to the sensor, but it will not be able to indicate the quality of the signal. With a lab scope, the unit can be checked while the monitored component is operating.

Connect the positive lead of the scope to the signal wire by backprobing the connector. The connector must be plugged into the Hall-effect sensor. With the component operating, or being rotated, the trace should show a clean 5-volt or 12-volt square wave pattern (based on design) that increases in frequency as shaft rpm increases (Figure 10-37). The voltage value should go to a full 5 or 12 volts. If it does not, then there is resistance on the signal circuit between the Hall-effect sensor and the computer. The voltage should also return to 0 volts. If it does not, then there is resistance on the ground circuit. In addition, a sloping rising and falling line may indicate that the tone wheel is too far away from the magnet of the Hall-effect sensor or that the transistor is faulty (Figure 10-38). Check the trace for glitches and noise that may be the result of RFI or EMI (Figure 10-39).

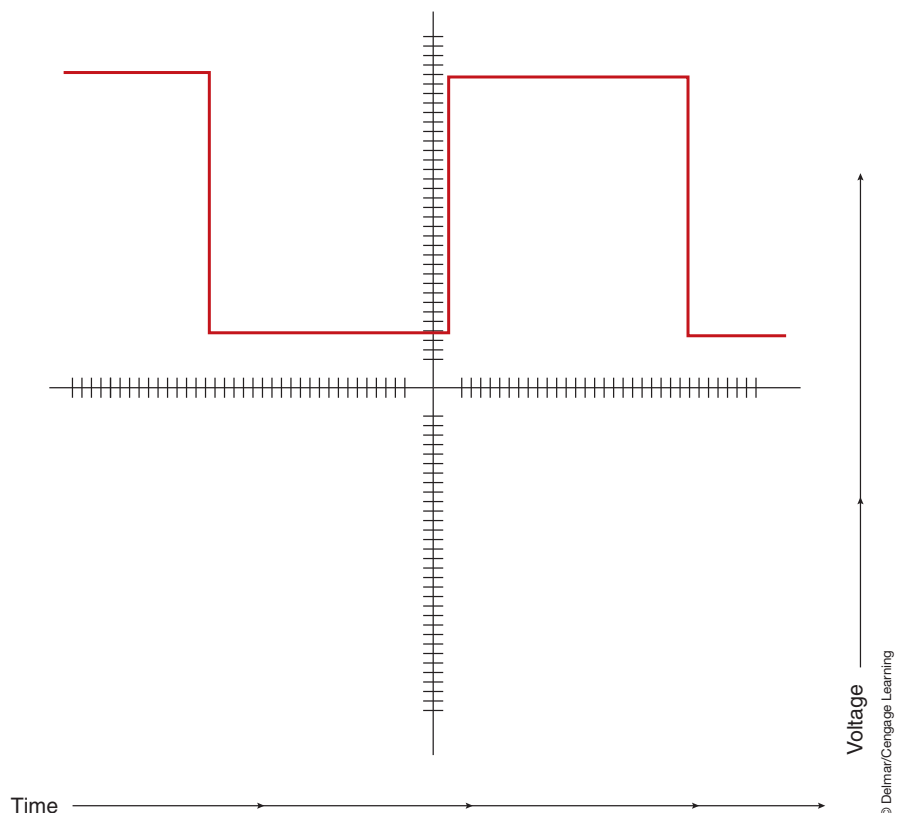
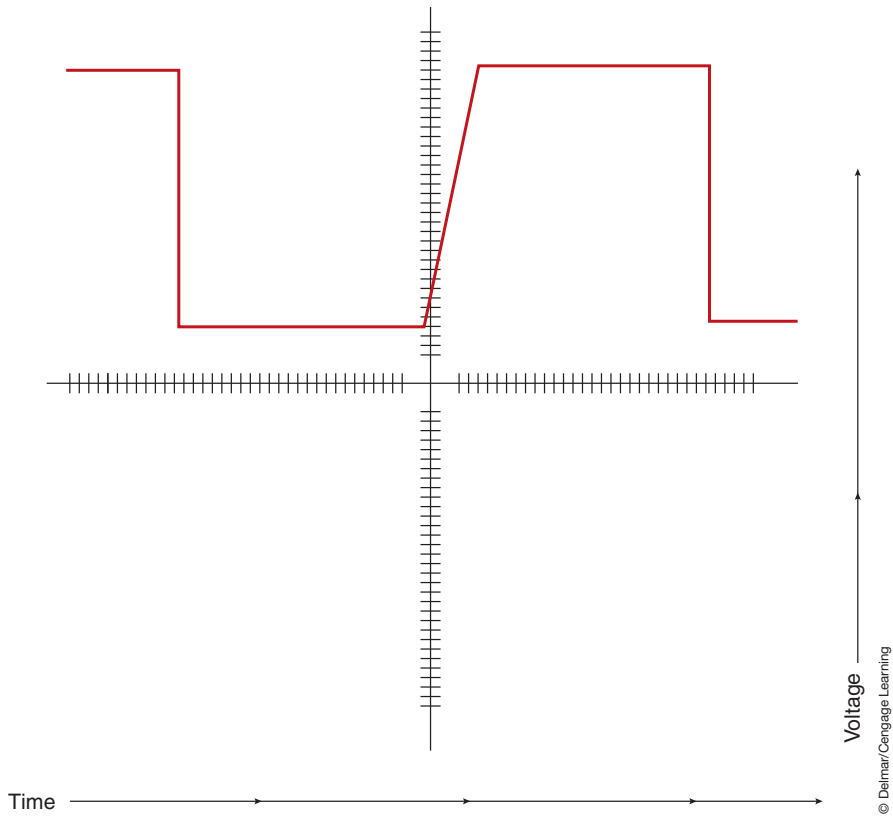


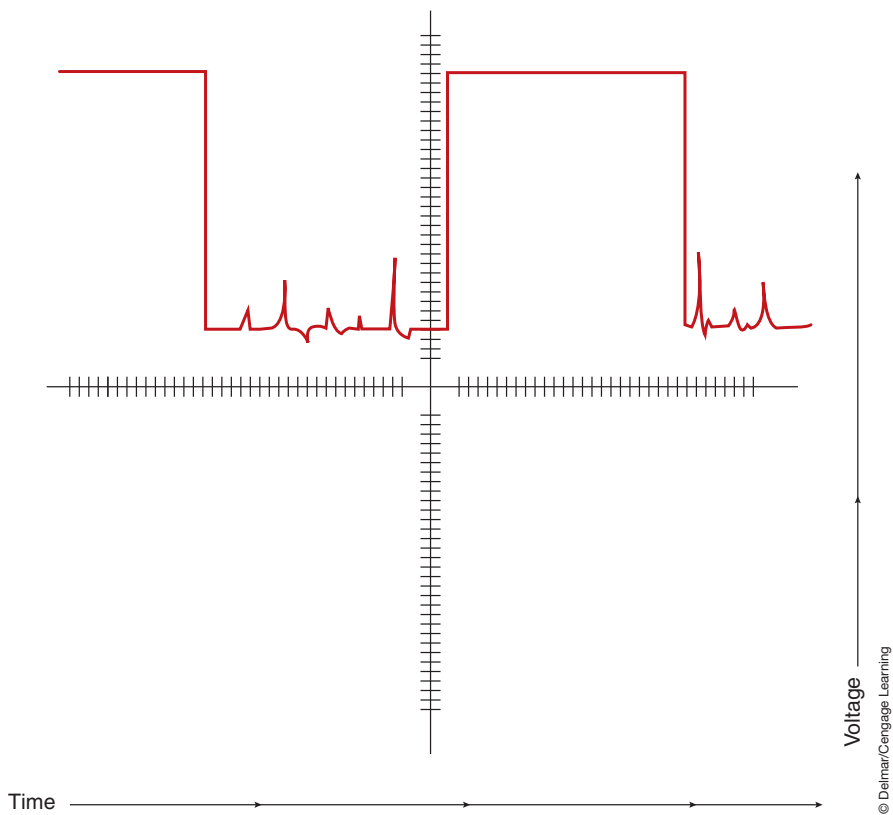
FIGURE 10-37 A good Hall-effect waveform should be a clean square wave pattern.

© Delmar/Cengage Learning





**FIGURE 10-38** A sloping edge on either the raising or falling side may indicate an air gap that is too wide or the transistor in the Hall-effect is faulty.



**FIGURE 10-39** The Hall-effect trace pattern should be free of glitches and noise.

## TERMS TO KNOW

- Air gap
- Capacitance discharge sensor
- Cold soak
- Dual ramping
- Environmental data
- Freeze frame
- Knock
- Knock sensor
- Magnetic induction sensors
- Magnetoresistive (MR) sensors
- Negative temperature coefficient (NTC)
- Piezoelectric sensors
- Piezoelectric

## TERMS TO KNOW

(continued)

transducer

Piezoresistive

Polymer

Positive temperature coefficient (PTC)

Potentiometer

Sensor dropout

Thermistor

Throttle position sensor (TPS)

Wheatstone bridge

## CASE STUDY

A customer brings her minivan to the shop with a concern that the power lift gate does not open when the key FOB or inside button is pressed. The technician confirms the problem. While testing the operation of the power lift gate, he notices that the latch releases when the outside handle is used. Using his scan tool he accesses the lift gate module, but no DTCs are set. While looking through the sensor data display on the scan tool, he notices that the door temperature sensor is reading 20°F (-6.7°C). The temperature in the shop is 77°F (25°C). Knowing that the lift gate will not open if the temperature is too cold, he removed the sensor and tested its resistance. The sensor tested

good. He then inspected the sensor connector, but found no problems. He then inspected the connector at the lift gate module, but could not find a problem. After consulting the wiring diagram, he located an in-line connector in the D-pillar area. After de-trimming the pillar, he noticed that the connector was corroded. Once the connector was cleaned, the sensor reading matched the temperature in the shop, and the lift gate operated properly. Prior to installing the D-pillar trim, he inspected for the cause of the corrosion and found signs of a small water leak from the tail light lens area. He also repaired the leak to assure the customer would not experience a repeat failure.

## ASE-STYLE REVIEW QUESTIONS

- Using the circuit illustrated in Figure 10-3, the computer has set a fault code for the sense circuit being high. *Technician A* says this can be caused by a short to chassis ground in the return circuit. *Technician B* says the signal circuit may be shorted to the return circuit. Who is correct?
  - A only
  - B only
  - Both A and B
  - Neither A nor B
- What is being tested in Figure 10-40?
  - Open in sensor signal circuit
  - Open in sensor return circuit
  - Short to ground in the signal circuit
  - Both A and B
- The voltmeter reading illustrated in Figure 10-41 indicates:
  - An open in the circuit between the control module and the motor
  - A properly operating PTC
  - An open PTC
  - None of the above
- A low voltage on the pressure sensor's supply circuit could be caused by any of the following EXCEPT:
  - An open in the supply circuit wire
  - A short to ground in the supply circuit wire
  - High internal resistance in the sensor
  - Excessive voltage drop in the supply circuit
- A high voltage on the pressure sensor signal wire would most likely be caused by which of the following?
  - An open in the supply circuit
  - An open in the signal circuit
  - A short to ground in the supply circuit
  - A short to ground in the signal circuit
- Technician A* says the knock sensor output voltage should increase as it detects an engine knock. *Technician B* says the knock sensor voltage should be a square wave pattern. Who is correct?
  - A only
  - B only
  - Both A and B
  - Neither A nor B

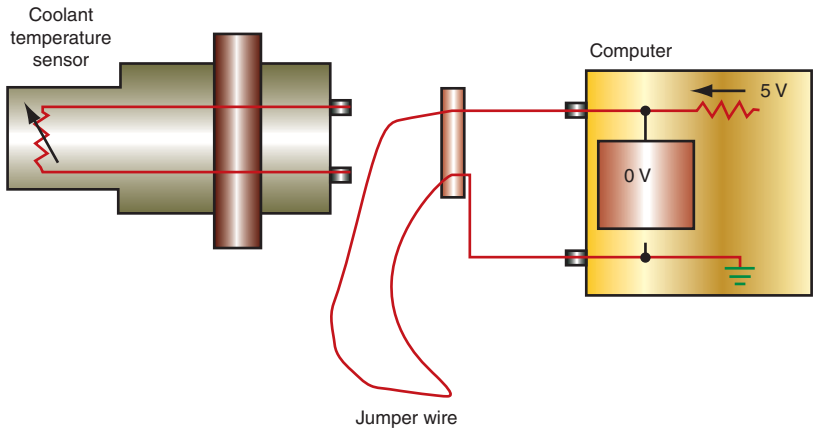


FIGURE 10-40

© Delmar/Cengage Learning

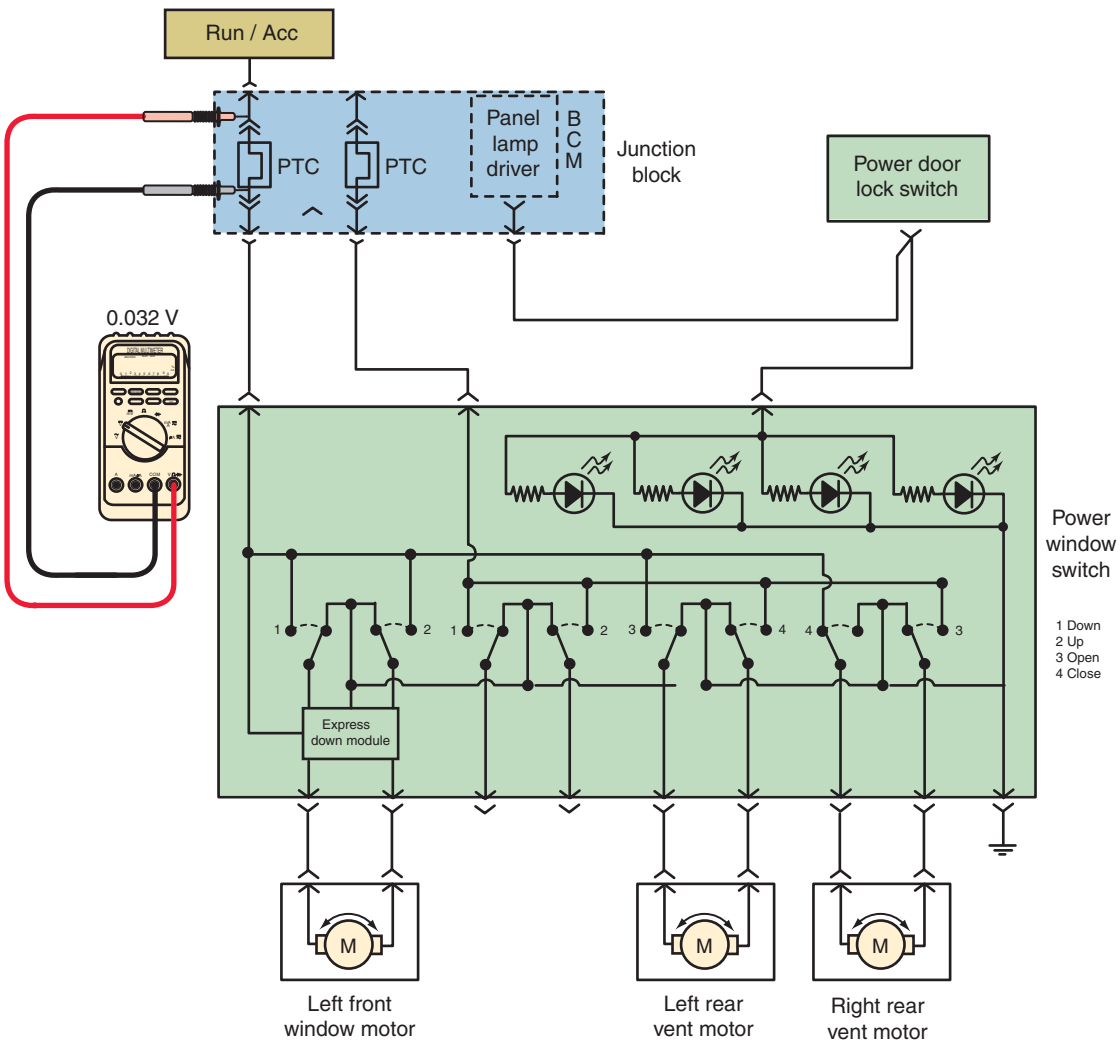


FIGURE 10-41

© Delmar/Cengage Learning

7. *Technician A* says a Hall-effect sensor that shows a trapezoidal-shaped waveform on the lab scope indicates the tone wheel air gap may be too wide.  
*Technician B* says the Hall-effect waveform should have round edges.  
Who is correct?  
A. A only                      C. Both A and B  
B. B only                      D. Neither A nor B
8. A potentiometer is suspected of being faulty. Voltmeter testing indicates there is 5 volts in the signal circuit when backprobed at the sensor, regardless of the wiper position.  
*Technician A* says this can be caused by an open sensor return circuit.  
*Technician B* says this can be caused by a short to ground in the supply circuit.  
Who is correct?  
A. A only                      C. Both A and B  
B. B only                      D. Neither A nor B
9. *Technician A* says a bent or damaged tone wheel could cause sensor dropout.  
*Technician B* says a damaged tone wheel could cause the output voltage to increase.  
Who is correct?  
A. A only                      C. Both A and B  
B. B only                      D. Neither A nor B
10. When inspecting magnetic reluctant-type sensors, all of the following must be checked EXCEPT:  
A. Bias voltage  
B. Proper contact between the sensor and the tone wheel  
C. Proper mounting of the sensor  
D. Tone wheel teeth condition

## ASE CHALLENGE QUESTIONS

1. The power seats do not move for or aft. The technician notices that the motor attempts to move the seat then stops. The least likely cause of this is:  
A. A binding track  
B. A short in the motor armature  
C. A faulty PTC  
D. An obstruction under the seat
2. The scan tool displays 5 volts for the ambient temperature sensor. This indicates:  
A. An open in the sensor return circuit  
B. An open in the signal circuit  
C. An open in the sensor  
D. All of the above
3. A customer states that their air-conditioning system does not work. It is observed that the A/C clutch does not turn on when the A/C button is activated.  
*Technician A* says this can be caused by an open in the high pressure cutout switch circuit.  
*Technician B* says this can be caused by a faulty AC pressure transducer.  
Who is correct?  
A. A only                      C. Both A and B  
B. B only                      D. Neither A nor B
4. *Technician A* says the MAP sensor reading with the KOEO should equal barometric pressure.  
*Technician B* says when the engine is started, the MAP sensor signal voltage should increase.  
Who is correct?  
A. A only                      C. Both A and B  
B. B only                      D. Neither A nor B
5. A vehicle with four-wheel ABS has a problem with the right rear wheel locking during heavy braking.  
*Technician A* says this could be caused by a bad speed sensor mounted at the wheel.  
*Technician B* says the speed sensor mounted at the differential could cause this problem.  
Who is correct?  
A. A only                      C. Both A and B  
B. B only                      D. Neither A nor B

Name \_\_\_\_\_ Date \_\_\_\_\_

## TESTING AN ENGINE COOLANT TEMPERATURE SENSOR

Upon completion of this job sheet, you should be able to check the operation of an ECT sensor and its associated circuits.

### ASE Correlation

This job sheet is related to the ASE Electrical/Electronic Systems Test's content area: *General electrical/electronic system diagnosis*, Task: Check voltages and voltage drops in electrical/electronic circuits with a voltmeter; determine needed repairs. Task: Check continuity and resistances in electrical/electronic circuits and components with an ohmmeter; determine needed repairs. Task: Check electrical/electronic circuits with jumper wires; determine needed repairs. Task: Find shorts, grounds, opens, and resistance problems in electrical/electronic circuits; determine needed repairs.

### Tools and Materials

Service information

DVOM

Lab scope

Scan tool

Jumper wires

Backprobing tools

### Describe the vehicle being worked on

Year \_\_\_\_\_ Make \_\_\_\_\_ Model \_\_\_\_\_

VIN \_\_\_\_\_ Engine type and size \_\_\_\_\_

## TASK ONE - TESTING THE SENSOR

### Procedure

Task Completed

1. Let the engine cool down completely.

2. Describe the location of the ECT sensor.

\_\_\_\_\_

3. What color of wires is connected to the sensor?

\_\_\_\_\_

4. Record the resistance specifications for a normal ETC sensor for this vehicle at shop temperature.

\_\_\_\_\_

5. Disconnect the electrical connector to the sensor.

6. Measure the resistance of the sensor. Record your results:  
\_\_\_\_\_ ohms at approximately \_\_\_\_\_ degrees.

---

**Task Completed**

7. If not within specifications, what is your next step?

---

---

8. If the sensor resistance in step 6 is good, reconnect the sensor wires and backprobe the signal circuit with a voltmeter or lab scope.

9. Start the engine and allow it to warm to normal operating temperature while recording your voltage readings at different temperatures.

---

---

10. Is the voltage change smooth or erratic?

---

11. Is the ETC a negative temperature coefficient (NTC) or positive temperature coefficient (PTC) thermistor?

---

12. Conclusions:

---

---

## TASK TWO - CIRCUIT TESTING

### Procedure

1. With the scan tool connected to the DLC, disconnect the sensor and observe the voltage on the scan tool with the ignition switch in the RUN position. Record your results:

---

2. If the voltage displayed is not correct, what would your next step be?

---

---

3. Use a jumper wire to short the two ECT sensor terminals together at the connector and observe the voltage displayed on the scan tool. Record your results:

---

4. If the voltage did not change, what would be your next step?

---

---

5. Describe what steps 1 and 3 have proven.

---

---

6. With the ignition switch in the OFF position, disconnect the PCM connector that houses the ECT sensor circuits.

7. Connect an ohmmeter test lead to each end of the ECT sensor sense circuit and record your results.

---



8. If the ohmmeter reading displayed is not correct, what would your next step be?

---

---

9. Connect an ohmmeter test lead to each end of the ECT sensor ground (return) circuit and record your results. \_\_\_\_\_

10. If the ohmmeter reading displayed is not correct, what would your next step be?

---

---

11. Connect one ohmmeter test lead to the ECT sensor ground (return) circuit and the other lead to the sense circuit at either connector. Record your results.

---

12. If the ohmmeter reading displayed is not correct, what would your next step be?

---

---

13. Conclusions:

---

---

Instructor's Response \_\_\_\_\_

---

---

*This page intentionally left blank*

Name \_\_\_\_\_ Date \_\_\_\_\_

## TESTING PTCs USED FOR CIRCUIT PROTECTION

Upon completion of this job sheet, you should be able to check the operation of PTCs that are used to protect a circuit from current overload.

### ASE Correlation

This job sheet is related to the ASE Electrical/Electronic Systems Test's content area: *General electrical/electronic system diagnosis*. Task: Inspect, test, and replace current limiting devices.

### Tools and Materials

Service information

DMM

Vehicle equipped with PTC circuit protection devices

### Describe the vehicle being worked on

Year \_\_\_\_\_ Make \_\_\_\_\_ Model \_\_\_\_\_

VIN \_\_\_\_\_ Engine type and size \_\_\_\_\_

### Procedure

Task Completed

1. Use service information to identify the PTC and its location from the circuit assigned to you by your instructor.

\_\_\_\_\_

\_\_\_\_\_

2. Disconnect the battery.

3. Use the ohmmeter function of the DMM to measure the resistance of the PTC.

\_\_\_\_\_

4. Based on this reading, what are your conclusions?

\_\_\_\_\_

\_\_\_\_\_

5. To test with a voltmeter, reconnect the battery.

6. Measure the voltage on the input side of the PTC. \_\_\_\_\_

7. Measure the voltage on the output side of the PTC.

\_\_\_\_\_

8. Connect the read test lead to the input side of the PTC and the black lead to the output side of the PTC and operate the system the PTC protects. Record the voltmeter reading.

\_\_\_\_\_

9. Based on your observations, what can you conclude about the functionality of the PTC?

---

---

Instructor's Response \_\_\_\_\_

---

---

Name \_\_\_\_\_ Date \_\_\_\_\_

## PRESSURE SWITCH ANALYSIS

Upon completion of this job sheet, you will be able to test determine the operation of a pressure switch.

### ASE Correlation

This job sheet is related to the ASE Electrical/Electronic Systems Test's content area: *General electrical/electronic system diagnosis*. Task: Check voltages and voltage drops in electrical/electronic circuits with a voltmeter; determine needed repairs. Task: Check continuity and resistances in electrical/electronic circuits and components with an ohmmeter; determine needed repairs. Task: Check electrical/electronic circuits with jumper wires; determine needed repairs. Task: Find shorts, grounds, opens, and resistance problems in electrical/electronic circuits; determine needed repairs.

### Tools and Materials

Service information

DMM

Jumper wires

Any vehicle with a pressure switch included in system operation (oil pressure switch, A/C high pressure cutout switch, transmission pressure switch, etc.)

### Describe the vehicle being worked on

Year \_\_\_\_\_ Make \_\_\_\_\_ Model \_\_\_\_\_

VIN \_\_\_\_\_ Engine type and size \_\_\_\_\_

### Procedure

1. What is the function of the pressure switch for the vehicle and system assigned to you?  
\_\_\_\_\_  
\_\_\_\_\_
2. Identify the circuit(s) to the pressure switch and draw a simple schematic of the circuit below.
3. Disconnect the switch connector and measure the voltage on the signal circuit with the ignition in the RUN position. Record your reading.  
\_\_\_\_\_

4. Is this within specifications?  Yes  No  
If no, list possible causes for the reading obtained.

---

---

5. Operate the system while the switch is disconnected. Record the results.

---

---

6. With the system still operating, use a jumper wire and short the signal circuit to the ground circuit. Record the results.

---

---

7. Based on your observations, is the switch a normally open or normally closed switch?

---

---

8. With the system turned off, measure the resistance of the switch. Record your readings.

---

9. With the system operating, measure the resistance of the switch. Record your readings.

---

10. Are the results those expected from the operation you determined in step 7?

Yes  No

If no, what could be the cause?

---

---

11. Based on your observations, describe the results of your evaluation of the knock sensor circuit.

---

---

Instructor's Response \_\_\_\_\_

---

---



Name \_\_\_\_\_ Date \_\_\_\_\_

## TESTING THE POTENTIOMETER

Upon completion of this job sheet, you should be able to inspect and test a potentiometer.

### ASE Correlation

This job sheet is related to the ASE Electrical/Electronic Systems Test's content area: *General electrical/electronic system diagnosis*. Task: Check voltages and voltage drops in electrical/electronic circuits with a voltmeter; determine needed repairs. Task: Check continuity and resistances in electrical/electronic circuits and components with an ohmmeter; determine needed repairs. Task: Check electrical/electronic circuits with jumper wires; determine needed repairs. Task: Find shorts, grounds, opens, and resistance problems in electrical/electronic circuits; determine needed repairs.

### Tools and Materials

Service information

Scan tool

DMM

Lab scope

### Describe the vehicle being worked on

Year \_\_\_\_\_ Make \_\_\_\_\_ Model \_\_\_\_\_

VIN \_\_\_\_\_ Engine type and size \_\_\_\_\_

### Procedure

1. Identify the purpose of the potentiometer for your assigned task.

---



---

2. Identify the color code and purpose of the circuits to the potentiometer.

---



---

3. Unplug the harness connector at the potentiometer and measure the voltage at each terminal with the ignition switch in the RUN position.

---



---

4. Do the voltage readings match specifications?  Yes  No  
If no, problem is indicated?

---



---

5. Measure the resistance across the potentiometer between the supply and ground terminals.

\_\_\_\_\_  
Specification: \_\_\_\_\_

6. Measure the resistance between the signal and ground circuits as you move the wiper of the potentiometer. Describe your results:

\_\_\_\_\_  
\_\_\_\_\_

7. Reconnect the harness connector to the potentiometer and backprobe the signal circuit terminal. With the ignition switch in the RUN position, what is the voltage on the signal circuit?

\_\_\_\_\_

8. Move the potentiometer through its entire sweep while observing the voltmeter. Describe your observations:

\_\_\_\_\_  
\_\_\_\_\_

9. What was the highest voltage observed? \_\_\_\_\_  
Specification: \_\_\_\_\_

10. Repeat steps 7 through 9 with a lab scope and record your observations:

\_\_\_\_\_  
\_\_\_\_\_

Instructor's Response \_\_\_\_\_

\_\_\_\_\_  
\_\_\_\_\_

Name \_\_\_\_\_ Date \_\_\_\_\_

## DMM TESTING OF THE MAGNETIC INDUCTION SENSOR

Upon completion of this job sheet, you will have inspected and tested the magnetic induction speed sensor used to monitor wheel speed for the ABS system using a DMM.

### ASE Correlation

This job sheet is related to the ASE Electrical/Electronic Systems Test's content area: *General electrical/electronic system diagnosis*. Task: Check voltages and voltage drops in electrical/electronic circuits with a voltmeter; determine needed repairs. Task: Check continuity and resistances in electrical/electronic circuits and components with an ohmmeter; determine needed repairs. Task: Check electrical/electronic circuits with jumper wires; determine needed repairs. Task: Find shorts, grounds, opens, and resistance problems in electrical/electronic circuits; determine needed repairs.

### Tools and Materials

Service information

DMM

Lift or jacks with stands

### Describe the vehicle being worked on

Year \_\_\_\_\_ Make \_\_\_\_\_ Model \_\_\_\_\_

VIN \_\_\_\_\_ Engine type and size \_\_\_\_\_

### Procedure

Task Completed

1. Safely lift the wheels of the vehicle from the ground.
2. Referring to the service information, identify the location of the RF wheel speed sensor connector. Where is it located?  
 \_\_\_\_\_  
 \_\_\_\_\_
3. Other than ABS, what other vehicle systems require information from the wheel speed sensors?  
 \_\_\_\_\_  
 \_\_\_\_\_  
 \_\_\_\_\_
4. Locate and disconnect the speed sensor two-way connector harness for the assigned wheel location.
5. Connect your DMM to the sensor side of the connector and measure the resistance across the two terminals of the sensor. \_\_\_\_\_  
 Specifications: \_\_\_\_\_

6. Set the DMM to read dc voltage and measure the voltage across the harness side of the connector with the ignition switch in the RUN position. \_\_\_\_\_

Specifications: \_\_\_\_\_

7. What is the purpose of this voltage?

\_\_\_\_\_  
\_\_\_\_\_

8. Reconnect the speed sensor and backprobe the (+) side of the connector. Read the voltage at this terminal \_\_\_\_\_

Did the voltage drop? \_\_\_\_\_

9. Backprobe the (+) and (-) terminals of the speed sensor and connect the voltmeter across the two terminals. With the voltmeter set to read ac voltage, have an assistant start the vehicle and accelerate to 10 mph and maintain that speed. Record the voltmeter reading \_\_\_\_\_

10. Accelerate to 20 mph and record the voltmeter reading \_\_\_\_\_

11. Explain your observations:

\_\_\_\_\_  
\_\_\_\_\_

12. Switch the DMM to read frequency and perform steps 8 and 9 again. Record your observations:

\_\_\_\_\_  
\_\_\_\_\_

Instructor's Response \_\_\_\_\_

\_\_\_\_\_  
\_\_\_\_\_

Name \_\_\_\_\_ Date \_\_\_\_\_

## LAB SCOPE TESTING A MAGNETIC INDUCTION SENSOR

Upon completion and review of this job sheet, you should be able to inspect and test an ABS wheel speed sensor with a lab scope.

### ASE Correlation

This job sheet is related to the ASE Electrical/Electronic Systems Test's content area: *General electrical/electronic system diagnosis*. Task: Check voltages and voltage drops in electrical/electronic circuits with a voltmeter; determine needed repairs. Task: Check continuity and resistances in electrical/electronic circuits and components with an ohmmeter; determine needed repairs. Task: Check electrical/electronic circuits with jumper wires; determine needed repairs. Task: Find shorts, grounds, opens, and resistance problems in electrical/electronic circuits; determine needed repairs.

### Tools and Materials

- Wiring diagram
- Lab scope
- Lift or jacks with stands

### Describe the vehicle being worked on

Year \_\_\_\_\_ Make \_\_\_\_\_ Model \_\_\_\_\_  
 VIN \_\_\_\_\_ Engine type and size \_\_\_\_\_

### Procedure

Task Completed

1. Safely lift the wheels of the vehicle from the ground.
2. Referring to the service information, identify the location of the assigned wheel speed sensor connector. Where is it located?  
 \_\_\_\_\_  
 \_\_\_\_\_
3. Other than ABS, what other vehicle systems require information from the wheel speed sensors?  
 \_\_\_\_\_  
 \_\_\_\_\_  
 \_\_\_\_\_  
 \_\_\_\_\_
4. Backprobe the speed sensor two-way connector harness for the RF wheel.
5. Connect the lab scope and observe the trace while the wheel is rotated at a constant speed. General results:  
 \_\_\_\_\_  
 \_\_\_\_\_

6. Increase the speed of the wheel while observing the graph.

General results:

---

---

7. Record the operational action of the speed sensor and make any recommendation.

---

---

Instructor's Response \_\_\_\_\_

---

---



Name \_\_\_\_\_ Date \_\_\_\_\_

## BUILDING MAGNETORESISTIVE SENSOR TESTER

### Tools and Materials

9-volt battery

Project enclosure (Radio Shack #270-1801)

9-volt battery

Snap connector (Radio Shack #270-324)

Mini alligator clips (Radio Shack #270-1540)

2 feet of red wire

2 feet of black wire

Green LED (Radio Shack #2710-022A)

LED holder (Radio Shack #2710-080)

220-ohm resistor (Radio Shack # 277-111)

### Procedure

1. Use the schematic shown in Figure 10-42 below to construct the sensor tester.
2. Backprobe the terminals of an active wheel speed sensor and turn the ignition switch to the run position. Connect the tester the terminals observing polarity and rotate the wheel. Describe your results:

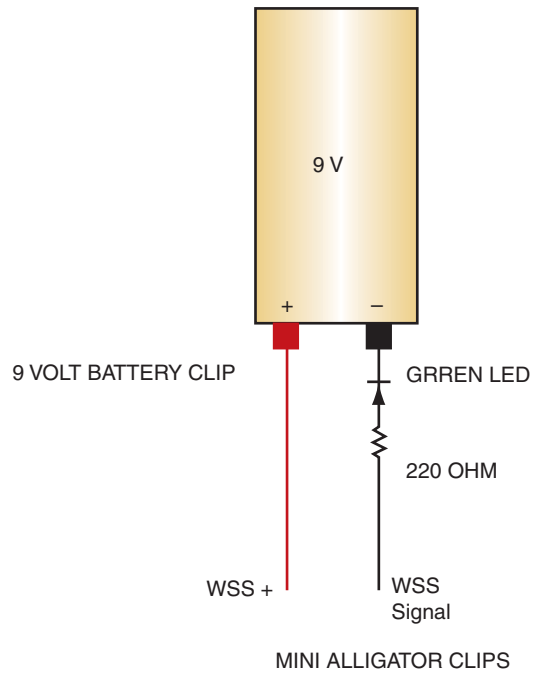
---

---

Instructor's Response \_\_\_\_\_

---

---



**FIGURE 10-42**

Name \_\_\_\_\_ Date \_\_\_\_\_

## ACTIVE SPEED SENSOR CIRCUIT DIAGNOSIS

Upon completion of this job sheet, you will have inspected and tested the speed sensor circuit.

### ASE Correlation

This job sheet is related to the ASE Electrical/Electronic Systems Test's content area: *General electrical/electronic system diagnosis*. Task: Check voltages and voltage drops in electrical/electronic circuits with a voltmeter; determine needed repairs. Task: Check continuity and resistances in electrical/electronic circuits and components with an ohmmeter; determine needed repairs. Task: Check electrical/electronic circuits with jumper wires; determine needed repairs. Task: Find shorts, grounds, opens, and resistance problems in electrical/electronic circuits; determine needed repairs.

### Tools and Materials

Service information  
 Scan tool  
 DMM

### Describe the vehicle being worked on

Year \_\_\_\_\_ Make \_\_\_\_\_ Model \_\_\_\_\_  
 VIN \_\_\_\_\_ Engine type and size \_\_\_\_\_

### Procedure

- Using the service information determine other than ABS, what other vehicle systems require information from the wheel speed sensors?

---



---



---



---

- Establish communication with the assigned vehicle using the scan tool and check for DTCs in the ABS system. Are any DTCs present?  Yes  No  
 If so, record them.

---



---

- If applicable, list the possible causes for the DTC(s).

---



---

---

Task Completed

4. Visually inspect the sensor wiring. Check for any chafed, broken, or pierced wires. Also visually inspect related harness connectors for broken, bent, spread, or pushed out terminals. Record your findings:

---

---

5. Inspect the tone wheel teeth for missing teeth, cracks, or looseness. Teeth should be perfectly square, not bent or nicked. Record your results:

---

---

6. Disconnect the WSS harness connector and use a DMM to measure the voltage of the supply circuit at the harness connector. What was the measured voltage? \_\_\_\_\_

7. Using a DMM, measure the voltage between the supply circuit and the signal circuit at the WSS harness connector. What were the results?

---

---

8. What do the results indicate?

---

---

□

9. Turn the ignition off and disconnect the ABM harness connector and the WSS connector.

10. Using a DMM, measure the resistance between the WSS signal circuit and the WSS supply circuit. What were the results?

---

---

11. What do the results indicate?

---

---

Instructor's Response \_\_\_\_\_

---

---

Name \_\_\_\_\_ Date \_\_\_\_\_

## TESTING THE HALL-EFFECT SENSORS

Upon completion of this job sheet, you will be able to test a camshaft and crankshaft position sensor.

### ASE Correlation:

This job sheet is related to the ASE Electrical/Electronic Systems Test's content area: *General electrical/electronic system diagnosis*. Task: Check voltages and voltage drops in electrical/electronic circuits with a voltmeter; determine needed repairs. Task: Check continuity and resistances in electrical/electronic circuits and components with an ohmmeter; determine needed repairs. Task: Check electrical/electronic circuits with jumper wires; determine needed repairs. Task: Find shorts, grounds, opens, and resistance problems in electrical/electronic circuits; determine needed repairs.

### Tools and Materials

- A vehicle equipped with an EI system
- Service information for the selected vehicle
- Lab scope
- DMM

### Describe the vehicle being worked on

Year \_\_\_\_\_ Make \_\_\_\_\_ Model \_\_\_\_\_  
 VIN \_\_\_\_\_ Engine type and size \_\_\_\_\_

### Procedure

1. Describe the location on the vehicle for the Hall-effect sensor assigned to you.  
 \_\_\_\_\_  
 \_\_\_\_\_
2. What is the function of this sensor in the system?  
 \_\_\_\_\_  
 \_\_\_\_\_
3. According to the service information, what should be the voltages at each of the terminals of the sensor with the ignition switch in the RUN position?  
 \_\_\_\_\_  
 \_\_\_\_\_
4. Disconnect the sensor connector and measure the voltage to each terminal (harness side) with the ignition switch in the RUN position. Do the voltages agree with those found in step 3?     Yes         No
5. If the voltages do not agree, what is the likely cause?  
 \_\_\_\_\_  
 \_\_\_\_\_

6. Reconnect all disconnected connectors. Connect the lab scope to read the signal from the sensors to the control module. Select the appropriate voltage level for the sensor.
7. Operate the system while observing the sensor signals. Describe the signals received.

---

---

8. Do any of the patterns indicate a problem?  Yes  No  
If so, what is the likely cause?

---

---

Instructor's Response \_\_\_\_\_

---

---



<b>DIAGNOSTIC CHART 10-1</b>	
PROBLEM AREA:	Temperature sensor circuit performance
SYMPTOMS:	Implausible voltage on the temperature sensor signal circuit Improper system operation Limp-in mode initiated
POSSIBLE CAUSES:	<ol style="list-style-type: none"> <li>1. Sensor signal circuit shorted to voltage</li> <li>2. Sensor signal circuit shorted to ground</li> <li>3. Sensor signal circuit shorted to sensor ground circuit</li> <li>4. Signal circuit open</li> <li>5. High resistance in signal circuit</li> <li>6. Sensor ground circuit open</li> <li>7. High resistance in sensor ground circuit</li> <li>8. Faulty sensor</li> <li>9. Internal controller fault</li> </ol>

<b>DIAGNOSTIC CHART 10-2</b>	
PROBLEM AREA:	Temperature sensor circuit voltage low
SYMPTOMS:	Improper system operation Limp-in mode initiated
POSSIBLE CAUSES:	<ol style="list-style-type: none"> <li>1. Sensor signal circuit shorted to ground</li> <li>2. Signal circuit open</li> <li>3. High resistance in signal circuit</li> <li>4. Sensor ground circuit open</li> <li>5. High resistance in sensor ground circuit</li> <li>6. Faulty sensor</li> <li>7. Internal controller fault</li> </ol>

<b>DIAGNOSTIC CHART 10-3</b>	
PROBLEM AREA:	Temperature sensor circuit voltage high
SYMPTOMS:	Improper system operation Limp-in mode initiated
POSSIBLE CAUSES:	<ol style="list-style-type: none"> <li>1. Sensor signal circuit shorted to voltage</li> <li>2. Signal circuit open</li> <li>3. High resistance in signal circuit</li> <li>4. Sensor ground circuit open</li> <li>5. High resistance in sensor ground circuit</li> <li>6. Faulty sensor</li> <li>7. Internal controller fault</li> </ol>

<b>DIAGNOSTIC CHART 10-4</b>	
PROBLEM AREA:	Malfunction pressure switch or circuit
SYMPTOMS:	Improper warning lamp operation Improper system operation Limp in mode initiated
POSSIBLE CAUSES:	<ol style="list-style-type: none"> <li>1. Open sense circuit</li> <li>2. Open ground circuit</li> <li>3. Sense circuit shorted to ground</li> <li>4. Sense circuit shorted to voltage</li> <li>5. Faulty pressure switch</li> </ol>

<b>DIAGNOSTIC CHART 10-5</b>	
PROBLEM AREA:	Pressure sensor signal voltage high
SYMPTOMS:	Improper system operation Limp-in mode initiated
POSSIBLE CAUSES:	<ol style="list-style-type: none"> <li>1. Open signal circuit</li> <li>2. Signal circuit shorted to voltage</li> <li>3. Supply circuit shorted to battery voltage</li> <li>4. Sensor ground circuit open</li> <li>5. Faulty sensor</li> <li>6. Internal controller fault</li> </ol>

<b>DIAGNOSTIC CHART 10-6</b>	
PROBLEM AREA:	Pressure sensor signal voltage low
SYMPTOMS:	Improper system operation Limp-in mode initiated
POSSIBLE CAUSES:	<ol style="list-style-type: none"> <li>1. Signal circuit shorted to ground</li> <li>2. Supply circuit shorted to ground</li> <li>3. Open supply circuit</li> <li>4. Faulty sensor</li> <li>5. Internal controller fault</li> </ol>

<b>DIAGNOSTIC CHART 10-7</b>	
PROBLEM AREA:	Piezoelectric sensor high-voltage fault
SYMPTOMS:	System malfunction
POSSIBLE CAUSES:	<ol style="list-style-type: none"> <li>1. Sensor signal circuit shorted to battery voltage</li> <li>2. Signal circuit open</li> <li>3. Sensor ground circuit open</li> <li>4. High resistance sensor ground circuit</li> <li>5. Faulty sensor</li> <li>6. Internal controller fault</li> </ol>

<b>DIAGNOSTIC CHART 10-8</b>	
PROBLEM AREA:	Incorrect reading from potentiometer
SYMPTOMS:	Sensor voltage at the controller is less than specifications
POSSIBLE CAUSES:	<ol style="list-style-type: none"> <li>1. Supply circuit open</li> <li>2. Supply circuit shorted to ground</li> <li>3. Signal circuit shorted to ground</li> <li>4. Signal circuit shorted to the sensor ground circuit</li> <li>5. Faulty sensor</li> <li>6. Internal controller fault</li> </ol>

<b>DIAGNOSTIC CHART 10-9</b>	
PROBLEM AREA:	Incorrect reading from potentiometer
SYMPTOMS:	Sensor voltage at the controller is higher than specifications
POSSIBLE CAUSES:	<ol style="list-style-type: none"> <li>1. Signal circuit shorted to battery voltage</li> <li>2. Signal circuit open</li> <li>3. Signal circuit shorted to the supply circuit</li> <li>4. Sensor ground circuit open</li> <li>5. Faulty sensor</li> <li>6. Internal controller fault</li> </ol>

<b>DIAGNOSTIC CHART 10-10</b>	
PROBLEM AREA:	Incorrect reading from potentiometer
SYMPTOMS:	Sensor voltage at the controller is not correct for position indicated by other inputs
POSSIBLE CAUSES:	<ol style="list-style-type: none"> <li>1. High resistance in the SIGNAL CIRCUIT</li> <li>2. High resistance in the sensor ground circuit</li> <li>3. High resistance in the voltage SUPPLY CIRCUIT</li> <li>4. Faulty sensor</li> <li>5. Internal controller fault</li> </ol>

<b>DIAGNOSTIC CHART 10-11</b>	
PROBLEM AREA:	No signal from magnetic induction sensor
SYMPTOMS:	No signal input detected by controller
POSSIBLE CAUSES:	<ol style="list-style-type: none"> <li>1. Sensor (+) circuit short to ground</li> <li>2. Sensor (-) circuit short to ground</li> <li>3. Sensor (+) circuit open</li> <li>4. Sensor (-) circuit open</li> <li>5. Sensor (+) circuit shorted to voltage</li> <li>6. Sensor (-) circuit shorted to voltage</li> <li>7. Sensor (-) circuit shorted to the sensor (+) circuit</li> <li>8. Excessive sensor air gap</li> <li>9. Faulty sensor</li> <li>10. Internal controller fault</li> </ol>

<b>DIAGNOSTIC CHART 10-12</b>	
PROBLEM AREA:	Intermittent signal from magnetic induction sensor
SYMPTOMS:	Sudden change of output signal from the sensor
POSSIBLE CAUSES:	<ol style="list-style-type: none"> <li>1. Sensor (+) circuit short to ground</li> <li>2. Sensor (-) circuit short to ground</li> <li>3. Sensor (+) circuit open</li> <li>4. Sensor (-) circuit open</li> <li>5. Sensor (+) circuit shorted to voltage</li> <li>6. Sensor (-) circuit shorted to voltage</li> <li>7. Sensor (-) circuit shorted to the sensor (+) circuit</li> <li>8. Excessive sensor air gap</li> <li>9. Faulty sensor</li> <li>10. Internal controller fault</li> </ol>

<b>DIAGNOSTIC CHART 10-13</b>	
PROBLEM AREA:	Incorrect signal from magnetic induction sensor
SYMPTOMS:	Incorrect reading from sensor as compared to other inputs
POSSIBLE CAUSES:	<ol style="list-style-type: none"> <li>1. High resistance in the sensor (+) circuit</li> <li>2. High resistance in the sensor (-) circuit</li> <li>3. Excessive sensor air gap</li> <li>4. Faulty sensor</li> <li>5. Internal controller fault</li> </ol>

<b>DIAGNOSTIC CHART 10-14</b>	
PROBLEM AREA:	Incorrect speed input from active magnetoresistive sensor
SYMPTOMS:	Incorrect reading from sensor as compared to other inputs.
POSSIBLE CAUSES:	<ol style="list-style-type: none"> <li>1. Wiring harness, terminal, connector damage</li> <li>2. Loose sensor mounting</li> <li>3. Damaged tone wheel</li> <li>4. Faulty sensor</li> <li>5. Internal controller fault</li> </ol>

<b>DIAGNOSTIC CHART 10-15</b>	
PROBLEM AREA:	Erratic performance from active magnetoresistive sensor
SYMPTOMS:	Signal is intermittently missing Periodic drop off of signal
POSSIBLE CAUSES:	<ol style="list-style-type: none"> <li>1. Wiring harness, terminal, connector damage</li> <li>2. Loose sensor mounting</li> <li>3. Damaged tone wheel</li> <li>4. Faulty sensor</li> <li>5. Internal controller fault</li> </ol>

<b>DIAGNOSTIC CHART 10-16</b>	
PROBLEM AREA:	Active magnetoresistive sensor circuit failure
SYMPTOMS:	No sensor output Sensor circuit fails the diagnostic test Sensor circuit low Sensor circuit high
POSSIBLE CAUSES:	<ol style="list-style-type: none"> <li>1. Wiring harness, terminal, connector damage</li> <li>2. 12-volt supply circuit shorted to ground</li> <li>3. Signal circuit shorted to ground</li> <li>4. 12-volt supply circuit shorted to voltage</li> <li>5. 12-volt supply circuit open</li> <li>6. Signal circuit shorted to voltage</li> <li>7. Signal circuit open</li> <li>8. Signal circuit shorted to 12-volt supply circuit</li> <li>9. Faulty sensor</li> <li>10. Internal controller fault</li> </ol>

<b>DIAGNOSTIC CHART 10-17</b>	
PROBLEM AREA:	Hall-effect sensor input missing
SYMPTOMS:	No signal is present during motion of monitored component
POSSIBLE CAUSES:	<ol style="list-style-type: none"> <li>1. Sensor voltage supply circuit shorted to battery voltage</li> <li>2. Sensor voltage supply circuit open</li> <li>3. Sensor voltage supply circuit shorted to ground</li> <li>4. Sensor signal circuit open</li> <li>5. Sensor signal circuit shorted to battery voltage</li> <li>6. Sensor signal circuit shorted ground</li> <li>7. Sensor signal circuit shorted to the voltage supply circuit</li> <li>8. Sensor ground circuit open</li> <li>9. Excessive sensor air gap</li> <li>10. Faulty sensor</li> <li>11. Internal controller fault</li> </ol>

<b>DIAGNOSTIC CHART 10-18</b>	
PROBLEM AREA:	Intermittent Hall-effect sensor input
SYMPTOMS:	Intermittent signal during motion of monitored component
POSSIBLE CAUSES:	<ol style="list-style-type: none"> <li>1. Sensor voltage supply circuit open</li> <li>2. Sensor voltage supply circuit shorted to ground</li> <li>3. Sensor signal circuit shorted to battery voltage</li> <li>4. Sensor signal circuit open</li> <li>5. Sensor signal circuit shorted ground</li> <li>6. Sensor signal circuit shorted to the voltage supply circuit</li> <li>7. Sensor ground circuit open</li> <li>8. Excessive sensor air gap</li> <li>9. Faulty sensor</li> <li>10. Damaged tone wheel</li> <li>11. Internal controller fault</li> </ol>

*This page intentionally left blank*



## VEHICLE MULTIPLEXING DIAGNOSTICS



### BASIC TOOLS

Hand tools  
Fender covers

### UPON COMPLETION AND REVIEW OF THIS CHAPTER, YOU SHOULD BE ABLE TO:

- Describe the purpose of U- and B-codes.
- Properly diagnose an ISO 9141-2 bus system and determine needed repairs.
- Properly diagnose an ISO-K bus system and determine needed repairs.
- Properly diagnose a class A bus system and determine needed repairs.
- Properly diagnose a J1850 bus system and determine needed repairs.
- Properly diagnose a Controller Area Network (CAN) bus system and determine needed repairs.
- Properly diagnose a local interconnect network (LIN) bus system and determine needed repairs.

### INTRODUCTION

If the vehicle's multiplexing system should fail, the symptoms can range from a single function (such as instrument gauges) not operating to multiple function failures, including engine no-start. Diagnosing the bus system is not much different than diagnosing any other electrical system. Begin by verifying the customer's complaint; determine if there are any related symptoms, and then analyze the symptoms to develop a logical troubleshooting plan. It is important to understand how the bus system you are diagnosing should operate and what are the normal voltages on the system. Bus system failures include circuit opens, shorts, high resistance, and component failures. In addition, do not be quick to condemn the bus system if a module is not communicating. It is possible the module is not powering up due to loss of battery voltage feed or loss of ground. This chapter discusses those items that the technician must be aware of while diagnosing different bus networks. The most common bus systems are discussed here.

Since most bus systems communicate with the scan tool, they will have a point of connection at the data link connector (DLC). To assist in testing of the data bus, a **J1962 breakout box (BOB)** is available (Figure 11-1). Since J1962 is the mandated DLC configuration for OBD II, this tool will work on any OBD II-compliant vehicle. The J1962 BOB provides a pass through test point that connects in series between the DLC and the scan tool. This provides easy testing of voltages and resistance of any of the DLC circuits without risk of damage to the DLC.

### COMMUNICATION FAULT CODES

Diagnostic trouble codes assigned to the vehicle communication network are called **U-codes**. These codes follow the same SAE guideline as the "P-codes" used for powertrain faults. The prefix "U" indicates the fault is associated with network communications.



© Delmar/Cengage Learning

**FIGURE 11-1** The J1962 BOB makes pin out testing of the DLC easier.

In addition, DTCs that are assigned to the vehicle's body systems and control modules are called **B-codes**. Typically, these codes refer to a failure of the system the module operates (such as a sensor failure). If a module relies on a bus message from another module but does not receive it, the first module may set both a U-code and a B-code. The U-code would be due to the loss of communication with the second module, and the B-code due to the system not able to perform a function. B-codes also follow the same SAE guideline as the P-code.

Most modules on the bus network are capable of setting U-codes if they detect abnormal conditions. Most bus modules can detect loss of communication conditions with one or more modules or a bus failure. Some modules may also be able to monitor the actual voltage on the bus circuits and set additional trouble codes for conditions such as voltage high, low, shorted, or open bus circuits.

In addition, most modules will report the status of the DTCs. If the conditions currently exist, then the DTC is reported as being active. If the condition no longer exists, then the DTC is reported as being stored.

**Classroom Manual**

Chapter 11, page 285



**SPECIAL TOOLS**

- J1962 BOB
- Scan tool
- DMM
- Lab scope

**ISO 9141-2 BUS SYSTEM DIAGNOSTICS**

The ISO 9141-2 standard bus system provides for communication links between the scan tool and the module. Many OBD II vehicles will use this protocol for communication to the powertrain control module (PCM). In addition, some manufacturers will use the system for communication between the scan tool and other modules on the vehicle (Figure 11-2).

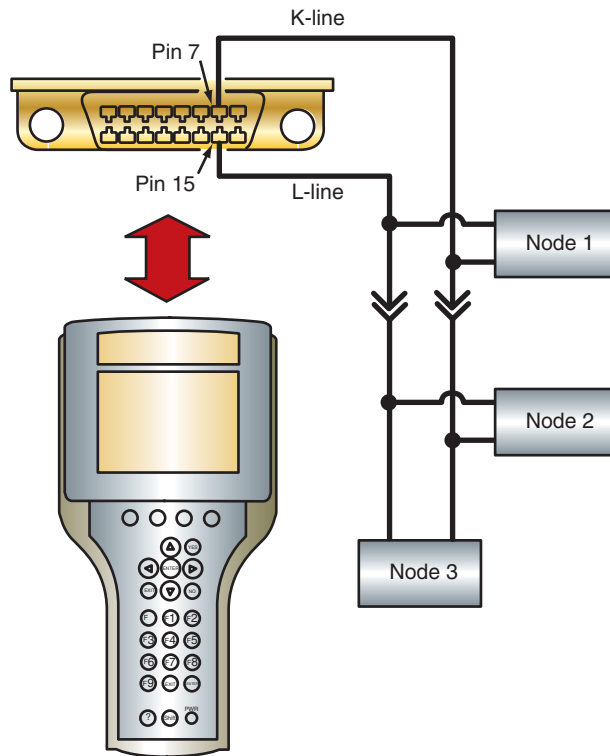
The ISO 9141-2 bus uses a K-line to transmit data from the module to the scan tool and an L-line for the module to receive data from the scan tool (Figure 11-3). The scan tool supplies bias to the module on the K-line, while the module supplies bias to the scan tool on the L-line. Communication occurs when the transmitting node pulls the voltage low. If a failure occurs in this bus system, then communications between the scan tool and the module will not be possible. Since this bus system is not used for communications between modules on the vehicle, the customer may not have any noticeable problems with vehicle or accessory operation.

When diagnosing a failure due to the scan tool not being able to communicate with the PCM, it is important to analyze the symptoms. Review the wiring diagram and bus system information in the proper service information to determine if other modules on the vehicle are diagnosed using the ISO 9141-2 bus system. If other modules are on the bus, then use the scan tool to attempt to connect with each of these modules. If the scan tool connects to any module using the ISO 9141-2 bus, then it is not a total bus failure and the technician will need to diagnose for a partial bus failure. If no modules respond, then the technician will need to diagnose for a total bus failure.



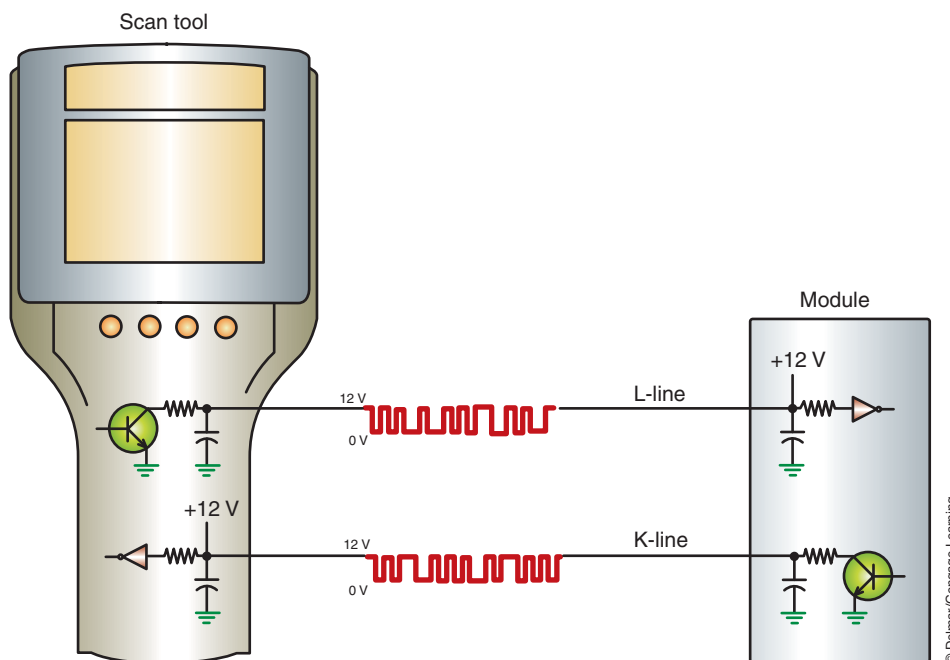
### SERVICE TIP:

Some scan tools provide a **vehicle module scan** function that will query all of the modules on the bus to respond and then list those that did reply. This makes it simple to see if any other modules are responding and which ones are not.



© Delmar/Cengage Learning

**FIGURE 11-2** ISO 9142-2 bus system used to communicate between the scan tool and modules on the vehicle.



© Delmar/Cengage Learning

**FIGURE 11-3** The K-line transmits data from the module to the scan tool and an L-line receives data from the scan tool.

Referring to Figure 11-2, if node 1 responded, but nodes 2 and 3 did not, then the first location to check would be the in-line connector. If nodes 1 and 3 only responded, then the problem is in the bus circuit to node 2. Since the circuit is wired in parallel, the problem cannot be a short to ground or voltage. Either the bus has an open between the splice and the node or the node is not powering up due to faulty battery feed or ground circuits.

If no module responds, then check voltages on the K-line and the L-line. Connect the J1962 BOB to the DLC and test for voltages at the proper terminals. Without the scan tool connected, there should be voltage only on the L-line. Voltage on the L-line is supplied by the module. Zero volts here can indicate an open circuit, or short to ground. Disconnect the battery and use an ohmmeter to determine the type of fault. If an open is indicated, the most likely location is between the DLC and the splice to the first node. A short to ground can be anywhere in the circuit. To locate the short, refer to the service information and determine if there is an in-line connector in the circuit. If the in-line connector is accessible, disconnect it and see if the resistance changes. If it does, then the short is downstream of the in-line connector. If the ohmmeter reading does not change, then the fault is between the DLC and the in-line connector. Next disconnect the modules on the side of the in-line connector that the fault was isolated to. After each module is disconnected, check the resistance reading. If disconnecting a module changes the reading, then that module has an internal fault and needs to be replaced. If the ohmmeter still indicates a short to ground after all of the modules are disconnected, then the fault is in the harness.

With the scan tool connected, voltage should be present on the K-line. Since the voltage on the K-line is supplied from the scan tool, zero volts on this line means that either the circuit is shorted to ground or the scan tool is faulty. Use an ohmmeter to determine if the K-line is shorted to ground. If so, follow the same procedure just described for the L-line to locate the short.

## Classroom Manual

Chapter 11, page 285



### SPECIAL TOOLS

J1962 BOB  
Scan tool  
DMM  
Lab scope

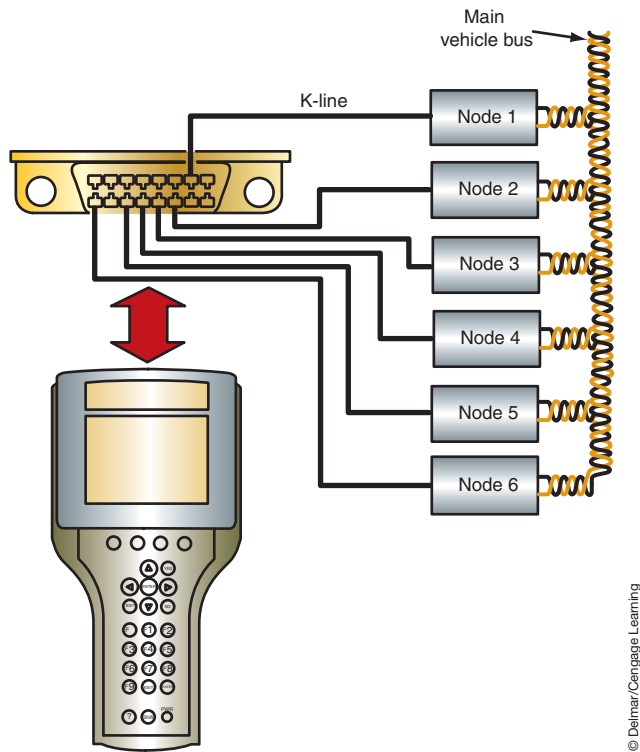
## ISO-K BUS SYSTEM DIAGNOSTICS

Vehicles that use ISO-K for the communication connection between the module and the scan tool may have their own dedicated lines from individual terminals in the DLC to the module (Figure 11-4). The K-line from the DLC to the PCM will be from terminal 7 of the DLC. The ISO-K bus is used only for communications between the scan tool and the module on a signal wire; it is not used for intermodule communications. The scan tool supplies the voltage onto the K-line.

If communications between the scan tool and module are not possible, begin diagnosis by connecting the J1962 BOB to the DLC. With the ignition key in the OFF position and the scan tool disconnected, there should be zero volts on the K-line. If voltage is present on this circuit at this time, there is a short to voltage between the DLC and the module, or internal of the module.

If zero volts are indicated, test for short to ground with an ohmmeter. If a short to ground is indicated, it may be in the wiring between the DLC and the module, or internal of the module.

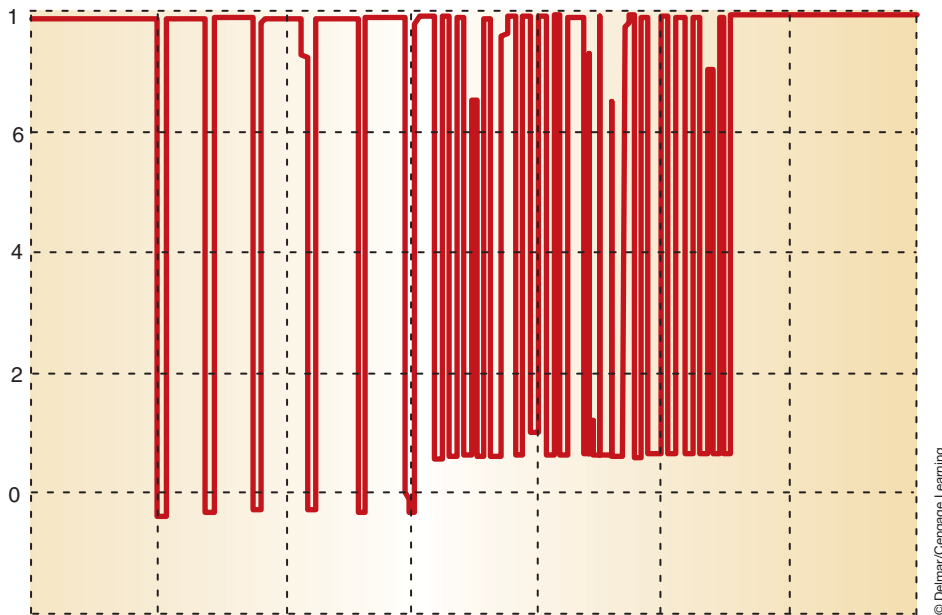
Next, connect the scan tool with the ignition switch in the OFF position. It would be best to use a lab scope to observe the voltages. Set the scope to read 10 ms per division on the time frame. At this time, up to 12 volts should be seen on the scope trace. While observing the scope trace, turn the ignition key to the RUN position and attempt to establish communications between the scan tool and the module. The scope trace should indicate a digital signal as communication is established and as data is transmitted (Figure 11-5). Notice in the scope trace that the biased voltage from the scan tool is about 10.5 volts. When the scan tool is attempting to request data from the module, the voltage is pulled low, to -0.5 volts. Finally, when the module is transmitting data to the scan tool, the voltage is pulled to +0.5 volts.



© Delmar/Cengage Learning

**FIGURE 11-4** An ISO-K bus circuit used to connect several modules to the scan tool. Each module uses its own dedicated circuit from the DLC.

Channel 1



© Delmar/Cengage Learning

**FIGURE 11-5** ISO-K transmission trace. The negative voltage is from the scan tool attempting to request data from the module. When the module is transmitting data to the scan tool the voltage is pulled down to +0.5 volts.



**SPECIAL TOOLS**

J1962 BOB  
Scan tool  
DMM  
Lab scope

## CLASS A BUS SYSTEM DIAGNOSTICS

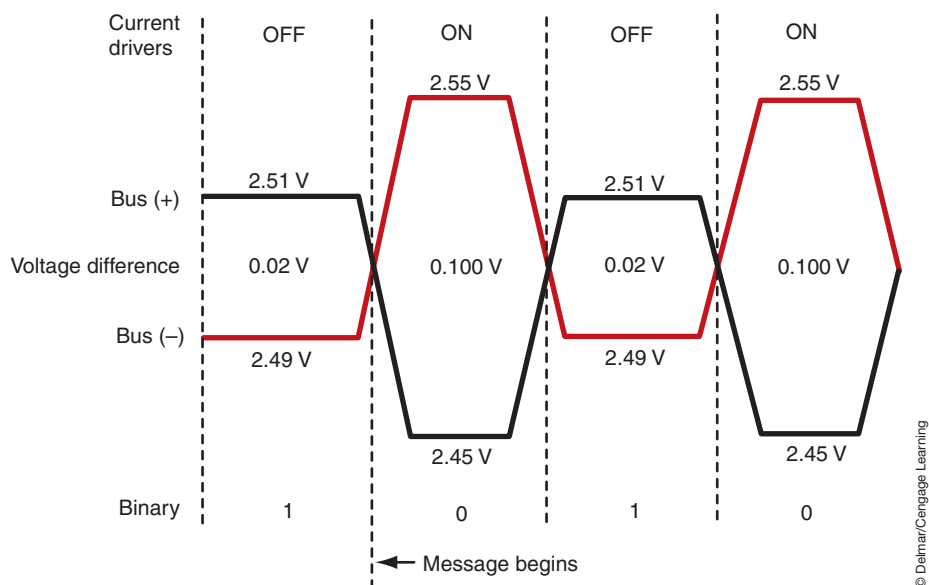
As discussed in the Classroom Manual, the class A bus system is a slow-speed bus. This system will have a master module and several slave modules. The master module will supply the bias voltage onto the bus system. If this module should fail, then no bus communications will be possible. In the Classroom Manual, the Chrysler Collision Detection (CCD) multiplexing system was presented as an example of how a class A bus operates. In this chapter, the CCD bus system will be used to provide an example of failure modes and how to diagnose a typical class A bus system.

Depending on scan tool type, the scan tool may attempt to diagnose the bus system if communication fails to occur. If this happens, the scan tool will display the cause of the problem on the screen. The messages displayed can be as follows:

- Bus (-) open.
- Bus (+) and bus (-) open.
- Bus (+) open.
- Bus (+) shorted to bus (-).
- Bus bias level too high.
- Bus bias level too low.
- Bus shorted to 5 volts.
- Bus shorted to battery voltage.
- Bus shorted to ground.
- No bus bias.
- No bus termination.
- Not receiving bus messages correctly.

The CCD bus network uses the voltage difference between the two wires to transmit data (Figure 11-6). The bus bias on the two wires is about 2.50 volts. The bus can operate with a voltage between 1.5 and 3.5 volts. Voltages that are outside of this range will not transmit data.

Since the CCD bus is a vehicle-wide bus system, failure of this bus will result in electrical systems not operating properly. First, determine if it is a total bus failure or a partial bus failure by attempting to communicate with all of the modules on the vehicle. If it is possible to communicate with a module on the bus system, then approach the diagnostics as a partial



**FIGURE 11-6** Normal CCD bus voltages during message transmission. Voltage difference is used to transmit the bit 1 or bit 0.



bus failure. If no modules can communicate with the scan tool, then a total bus failure is indicated.

If a total bus failure is indicated, then possible causes include:

- A faulty master module.
- Faulty power or ground circuits to the master module.
- An open in one of the bus circuits from the master module.
- A short to ground in one of the bus circuits.
- A short to voltage in one of the bus circuits.
- The two bus wires are shorted together.

To determine the type of fault that is causing total bus failure, use the J1962 BOB and connect it to the DLC. Measure the voltage on each bus circuit. The CCD system uses pin 3 of the DLC for CCD (+) and pin 11 for CCD (-). CCD (+) should have 2.49 volts with the ignition key in the RUN position. CCD (-) should have 2.51 volts.

If the voltmeter reads 12 volts on either circuit, that circuit is shorted to battery voltage. To isolate the location of the short, turn the ignition switch to the OFF position and watch the voltmeter. If the voltage drops, then the short is to ignition switched voltage. If the voltage is still reading battery voltage, the circuit is shorted to a direct battery feed. Remove fuses and relays one at a time while watching the voltmeter. If the voltage drops after a fuse or relay is pulled, note the identification of the fuse or relay and use the service information to determine what circuits and components are protected by that fuse or controlled by that relay. Once this is known, return to the vehicle, reinstall the fuse, and begin to unplug each component one at a time while observing the voltmeter. Once a component is unplugged and the voltage drops to normal, that component is the fault. If all components are unplugged and the voltage is still high, the fault is in the wiring of the circuit for those components.

If the voltmeter indicated zero volts on either or both of the bus circuits, then the cause can be an open or a short to ground. To determine the type of fault, use an ohmmeter and measure the termination resistance of the bus system by disconnecting the battery and placing the test leads into pins 3 and 11. Most CCD bus systems will have 60 ohms of termination resistance. However, some vehicles will have 120 ohms of termination resistance, so it is important to check the service information.

If the system should have 60 ohms and the ohmmeter reads 120 ohms, then one of the termination resistors is open or there is an open in the bus circuit to a module that has one of the termination resistors. Usually the termination resistors will reside in the PCM and the BCM. Each of these modules will have a 120-ohm termination resistor (Figure 11-7). To locate the open resistor, disconnect either the PCM or BCM while observing the ohmmeter. If the resistance does not change, then the termination resistor that is open is in the module that was just unplugged. If the resistance changes to infinite, the remaining termination resistor in the circuit was just removed, so the fault is within the termination of the other module. Before replacing the module, check for an open in the bus circuits to that module. If the bus circuits are good, and module power and ground circuits are confirmed, replace the module.

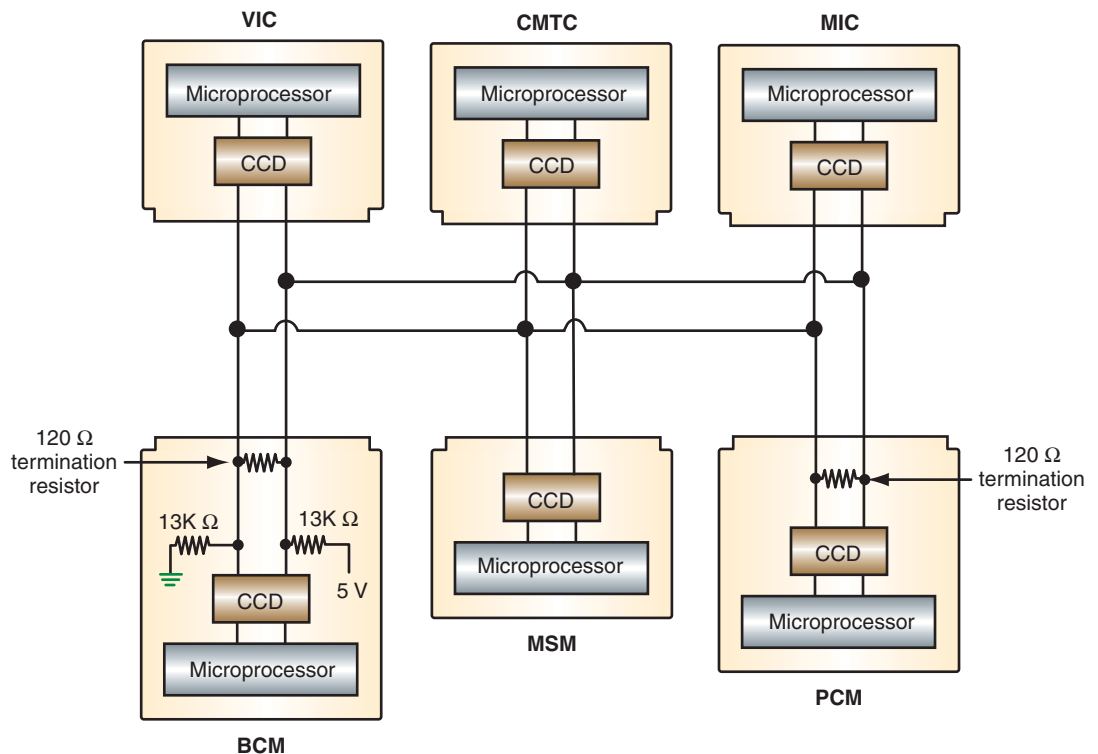
If termination resistance is normal and there is no indication of a short to ground on any of the bus circuits, the fault is probably the master module not powering up and thus not able to supply the bias for the bus. Usually the master module is the BCM in the CCD bus system. Confirm the power and ground circuits are good before replacing the BCM.

If ohmmeter testing indicates a short to ground in one of the bus circuits, isolation of the fault must still be performed. The fault may be a faulty module that has an internal short, or it could be the bus wire is shorted to ground within the wiring harness. The system circuit needs to be broken down into smaller sections to isolate where the fault is. Examine the wiring diagram for the vehicle and determine if there is a connector that would separate the bus network. Identify any connectors that can be used and their location. With the ohmmeter measuring resistance between the affected circuit and chassis ground, unplug the connector.



#### SERVICE TIP:

The PCM does not communicate with the scan tool on the CCD bus. It uses the K-line for this purpose. Do not be fooled into thinking that the problem is a partial CCD bus failure based on the response of the PCM.



**FIGURE 11-7** Usually two modules will have termination resistors. Total circuit resistance will be 60 ohms.

© Delmar/Cengage Learning



### SERVICE TIP:

If the scan tool cannot communicate with the PCM, and other modules on the CCD bus system have logged a loss of communication fault code against the PCM, check the common voltage supply circuits to the sensors. If these circuits short to ground, the PCM will turn off. This will also result in a no-start, and the PCM may not store any DTCs.

If the ohmmeter still reads low resistance, the fault is between the DLC and the connector. If the ohmmeter reads infinite, the fault is downstream of the connector. Now that this is known, move the ohmmeter test leads (if necessary) to observe resistance readings, as modules on the appropriate side of the connector are unplugged. If the readings change after a module is unplugged, then that module is the fault. If the reading is still low after all modules are unplugged, the fault is in the wiring harness.

If the initial tests indicate a partial bus failure, try to determine which modules are not communicating. If there is more than one, use the wiring diagrams for the vehicle to determine if there is anything common between the affected modules. For example, look for a common connector, common splice, common voltage supply to the modules, or common ground for the modules. Locate this common component on the vehicle and confirm proper function and repair as needed.

When diagnosing the CCD bus system, remember the following:

1. Normal bus voltages with the ignition switch in the RUN position are approximately 2.5 volts.
2. Normal bus voltages with the ignition switch in the OFF position are zero volts on both circuits.
3. Normal termination resistance is typically 60 ohms.
4. The wires must be twisted at the rate of one twist every 1¾ inches (44 mm).

## J1850 BUS SYSTEM DIAGNOSTICS

The J1850 bus system can be either a 10.4 Kb/s variable pulse width modulated (VPWM) system or a 41.6 Kb/s pulse width modulated (PWM) system. In the Classroom Manual, the Programmable Communication Interface (PCI) bus system that Chrysler uses was discussed. This system is similar to the class 2 bus system that General Motors uses as well. This system will be discussed here as an example of failure modes and how to diagnose a typical J1850 bus system.

### Classroom Manual

Chapter 11, pages 285, 290

Since the PCI bus is a vehicle bus system, a failure in it will cause electric systems to not operate properly. Like the other bus system diagnostics just discussed, begin by determining if the problem is a total bus failure or a partial bus failure.

If a total bus failure is indicated, then the system needs to be tested for proper voltage and termination resistance. Use the J1962 BOB to provide a diagnostic test point to measure these values. Total bus failure can only occur if there is a short to voltage or a short to ground in the circuit. Termination resistance will be different on every vehicle since each module provides its own termination. Since vehicles will have different options on them, the resistance will be different between vehicles. However, by measuring the resistance between pin 2 of the DLC (at the J1962 BOB) and chassis ground, a low reading will confirm a short to ground in the system. The procedure to locate this type of fault is presented later.

The normal voltage on the PCI bus is zero volts when it is at rest, and the voltage pulls up to near 7.5 volts when the bus is active (Figure 11-8). The best method of determining proper voltage on this system is with a lab scope. A DMM set to the voltmeter will not be able to give actual voltage values since the activity is too fast, so the meter will display the average. The MIN/MAX feature of the voltmeter will freeze the readings, but they still will not be actual voltages. However, the voltmeter will indicate if the bus is shorted to battery voltage (12 volts) or is a short to ground (0 volts). A reading of zero volts may also indicate an open, but this type of fault will not result in total bus failure.

If a short to battery voltage is indicated, then the location of the fault needs to be isolated. In order to do this, the system needs to be broken down into manageable pieces or smaller circuits. With the voltmeter still measuring PCI voltage, turn the ignition key to the OFF position. Wait for 20 seconds and read the voltmeter again. If the voltmeter now reads zero volts, then the bus network is shorted to ignition switched voltage. If the voltmeter still reads battery voltage, then the bus is shorted to direct battery voltage. In either case, the circuit that is shorted to the bus network can be further isolated by pulling fuses and relays one at a time while watching the voltmeter. If the voltage drops after a fuse or relay is pulled, note the identification of the fuse or relay and use the service information to determine what circuits and components are protected by that fuse or controlled by that relay. Once this is known, return to the vehicle, reinstall the fuse, and begin to unplug each component one at a time while



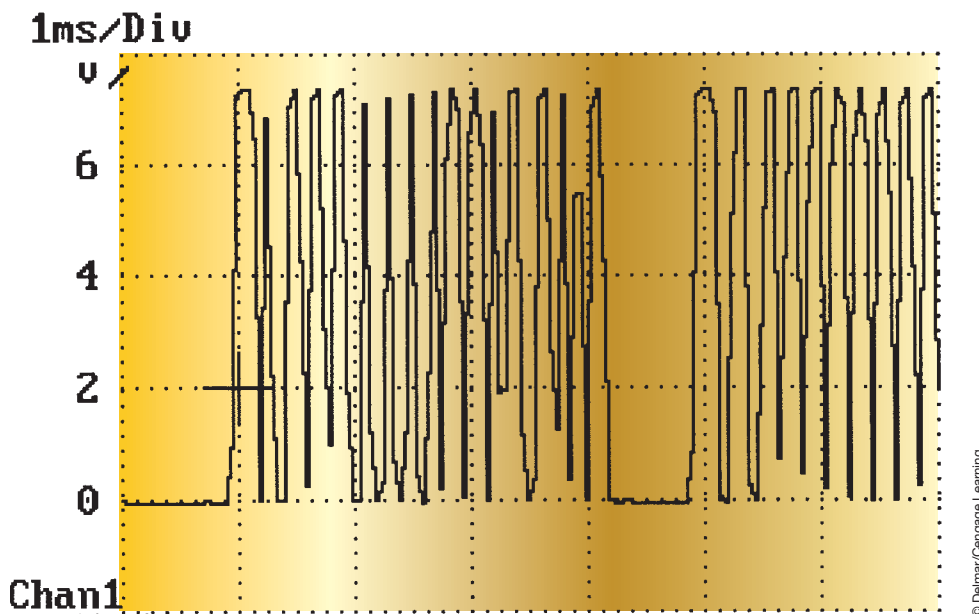
## SPECIAL TOOLS

J1962 BOB

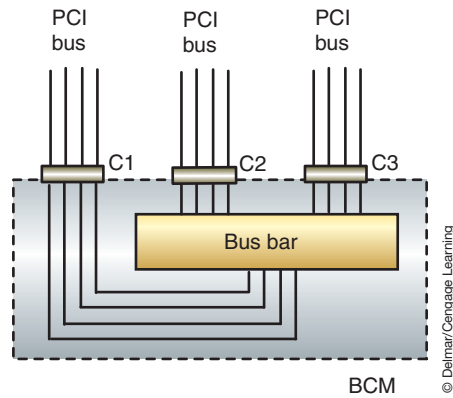
Scan tool

DMM

Lab scope



**FIGURE 11-8** The normal voltage on the PCI bus is 0 volts when it is at rest. To transmit data, the voltage is pulled up to near 7.5 volts.



**FIGURE 11-9** Common hub or bus bar within a controller helps make isolating the cause of bus failures easier for the technician.

observing the voltmeter. Once a component is unplugged and the voltage drops to normal, that component is the fault. If all components are unplugged and the voltage is still high, the fault is in the wiring of the circuit for those components.

If a short to ground was indicated while testing the termination resistance as discussed earlier, isolation of the fault must still be performed. The fault may be a faulty module that has an internal short, or it could be the PCI bus wire is shorted to ground within the wiring harness. Again the trick is to break the system down into smaller circuits. Depending on how the vehicle is wired, some may use a common hub for all of the bus circuits. If this is the case, this location provides an excellent place to begin diagnostics. For example, Figure 11-9 shows a PCI bus system that uses the BCM for a common hub for the bus. The BCM has three connectors attached to it that contain the different bus circuits from all of the modules. By unplugging these connectors (one at a time) and observing system operation, the system can be broken down into a few circuits. Once a connector is unplugged and some of the bus systems become active, the fault is within the bus circuits of that connector. It is possible that the connector has several bus wires in it. Use the ohmmeter to determine which bus wire is shorted to ground. Use the service information to determine what module is on that circuit and unplug the module. Again, measure resistance between the BCM connector and chassis ground. If the reading is infinite, the module is the fault. If the reading is still low, the wire is shorted to ground.

If the bus system does not have a common hub, examine the wiring diagram for the vehicle and determine if there is a connector that would separate the bus network. Identify any connectors that can be used and their location. With the ohmmeter measuring resistance between pin 2 of the DLC (using the J1962 BOB) and chassis ground, unplug the connector. If the ohmmeter still reads low resistance, the fault is between the DLC and the connector. If the ohmmeter reads any other value, the fault is downstream of the connector. Now that this is known, move the ohmmeter test leads (if necessary) to observe resistance readings, as modules on the appropriate side of the connector are unplugged. As before, if the readings change after a module is unplugged, then that module is the fault. If the reading is still low after all modules are unplugged, the fault is in the wiring harness.

If the initial tests indicate a partial bus failure, try to determine which modules are not communicating. If there is more than one, use the wiring diagrams for the vehicle to determine if there is anything common between the affected modules. For example, look for a common connector, common splice, common voltage supply to the modules, or common ground for the modules. Locate this common component on the vehicle and confirm proper function and repair as needed.

## CONTROLLER AREA NETWORK BUS DIAGNOSTICS

Vehicles that utilize Controller Area Network (CAN) bus systems will generally have two or three different CAN systems. The vehicle body systems will communicate over the medium speed CAN B network. Those systems such as engine controls and antilock brakes that require data at a faster rate will communicate on the CAN C bus. Beginning in the 2005 model year, manufacturers have started migrating to the new requirement for using a CAN bus network for diagnostics (often referred to as diagnostic CAN C).

The first step after verifying the customer's complaint is to determine which bus network is at fault. Usually this can be easily determined by a scan tool. Use the scan tool to access the central gateway module (CGW) for the bus networks. Since this is the common component for all three CAN bus networks, it will usually provide a DTC that will indicate which bus network has the fault. If the scan tool cannot communicate to the central gateway module, then the diagnostic CAN C circuit is faulty.

Once the faulty network is identified, diagnostics of either CAN network can be performed using a DMM or a lab scope. However, methods are different based on the network and the type of fault. The following diagnostic procedure should be followed to isolate the cause:

1. If the fault code indicates an open circuit fault with either the CAN B (+) or the CAN B (-) circuit (Figure 11-10), then determine and locate an easily accessed module on the CAN B bus system. At the connector for this component, create a short to ground on the opposite CAN B circuit. For example, if the fault code indicates that the CAN B (-) is open, then short the CAN B (+) circuit to ground. Since CAN B buses that operate at speeds up to 125 Kb/s are fault tolerant and will operate in single-wire mode as long as an electrical potential exists between one of the circuits and ground, the open may not cause any noticeable symptoms. However, when the other circuit is shorted to ground, that module can no longer communicate. All other modules will communicate using the single-wire mode (Figure 11-11). With the wire shorted to ground, use the scan tool to determine which module is not communicating on the bus. Locate this module on the vehicle. The fault will be between the splice from the affected bus circuit to the module.
2. If the fault code indicates one of the CAN B circuits is high or low, then use a DMM to determine if the fault is a short to voltage (12 volts) or shorted to ground (0 volts). If the voltage on both circuits is between 500 mV and 1.0 volts, the two circuits are shorted together. Locating a shorted circuit will be similar to the procedure described earlier for the J1850 VPWM bus. Use the wiring diagram for the vehicle and determine if connectors are used that can break the circuits down into smaller sections. Return to the vehicle and, with a voltmeter connected to the shorted circuit, observe the readings while opening the connectors. Once it is determined which side of the connector has the short, modules or other connectors on that branch of the circuit can then be disconnected to locate the root cause of the failure.
3. If the fault code indicates both CAN B (+) and CAN B (-) circuits are low or high, this indicates that a total bus failure has occurred. Symptoms may include headlamps on, warning indicator lamps on in the instrument panel, instrument panel backlighting at full intensity, gauges inoperative, and possible no-start. To locate the cause of this failure, use the diagnostic procedure for locating a short circuit, as previously described in 2.
4. Some modules do not set specific codes that isolate the type of fault. They will set a generic "CAN B BUS" fault. First determine if the single-wire failure is an open or short by measuring the voltages at an easily accessed module connector. If this fault is set due to an open, short to ground each CAN B circuit one at a time while monitoring the scan tool and observing symptoms. If shorting one of the circuits to ground does not affect operation or set additional DTCs, remove the short and repeat the procedure on the

### Classroom Manual

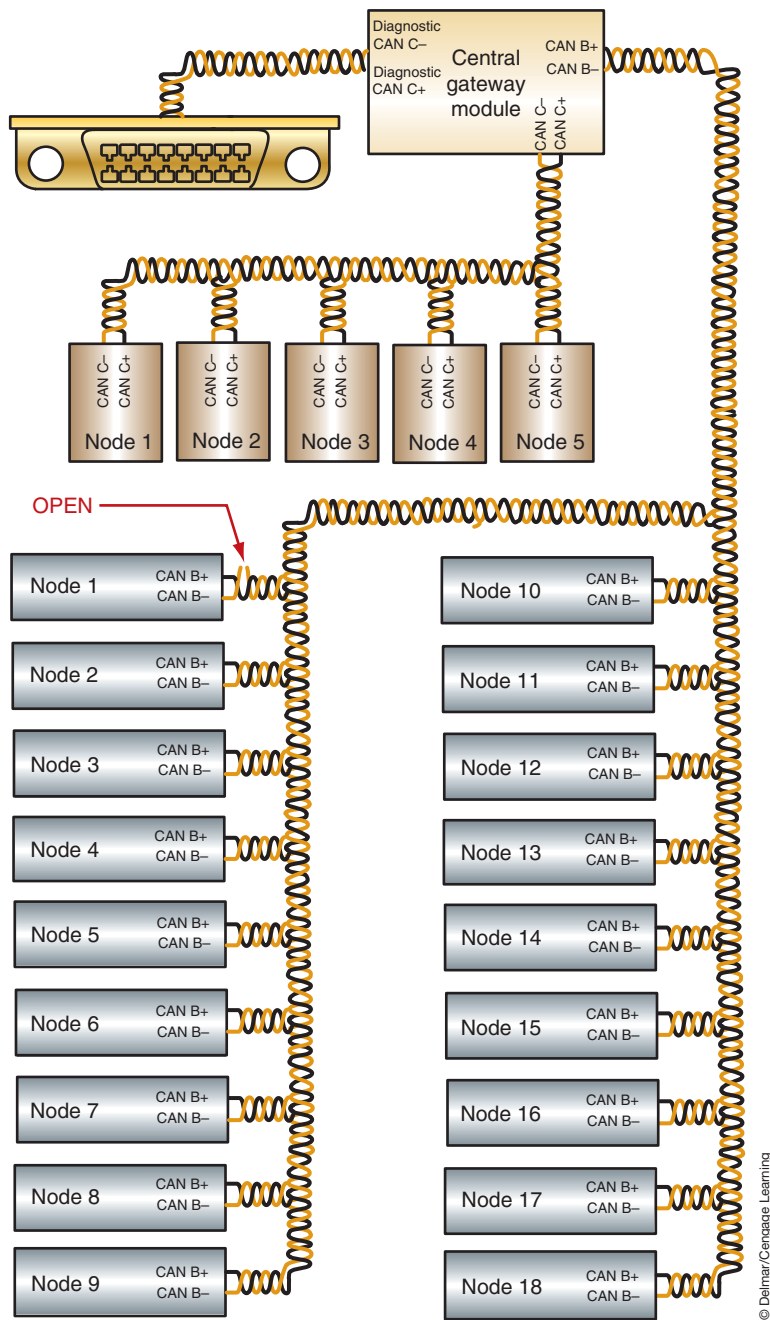
Chapter 11,  
pages 286, 292



### SPECIAL TOOLS

J1962 B0B  
Scan tool  
DMM  
Lab scope



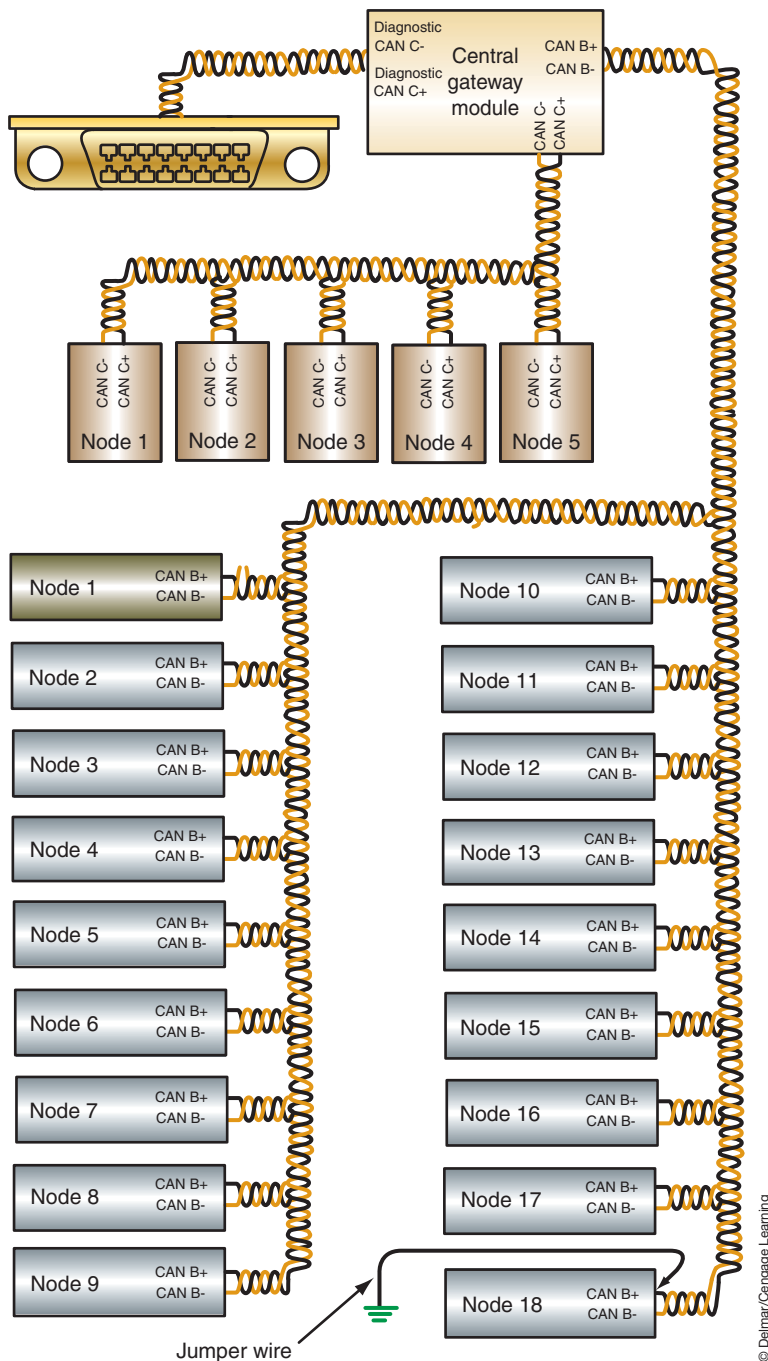


**FIGURE 11-10** An open bus(-) wire at CAN B bus Node 1 does not prevent the other nodes from being active on the bus.

other CAN B circuit to determine where the open exists. The open will be on the CAN B circuit that was *not* shorted to ground. If the tests indicate that the circuit(s) is shorted to ground, shorted to voltage, or shorted to each other, then follow the diagnostic procedure outlined previously in 2.

5. If the fault code indicated that a CAN C circuit is shorted, this would cause a total failure of the CAN C bus. The short can be to voltage, ground, or the two circuits together. Symptoms may include illuminated warning indicator lamps in the instrument panel, inoperative gauges, and possible no-start. To locate the short circuit, determine if it is caused by a defective module by disconnecting the modules one at a time and observing symptoms and ohmmeter readings on the CAN circuit. If





**FIGURE 11-11** When the bus(+) wire at CAN B bus node 18 is shorted to ground all modules continue to communicate except Node 1. Node 1 cannot communicate since it no longer has a circuit.

disconnecting all of the modules fails to indicate a faulty module, the problem is in the wiring harness.

6. If the fault code indicates a loss of communication with a single module (on either the CAN B or CAN C network), check for proper power and ground circuit at the affected module. If these circuits are confirmed good, then test the CAN circuits for opens between the splice to the network and the module. If the circuits do not have an open, replace the module.

**CUSTOMER CARE:** Modules can be very expensive and should be replaced only after all power feeds and ground circuits are tested and confirmed good.

**When diagnosing the CAN bus networks, remember these facts:**

1. A normal voltmeter reading on the CAN B (+) circuit with the ignition key in the RUN position is between 280 and 920 mV.
2. A normal voltmeter reading on the CAN B (-) circuit with the ignition key in the RUN position is between 4.08 and 4.72 volts.
3. A normal voltmeter reading on the CAN B (+) circuit with the ignition key in the OFF position and the bus asleep is zero volts.
4. A normal voltmeter reading on the CAN B (-) circuit with the ignition key in the OFF position and the bus asleep is battery voltage.
5. CAN B termination resistance cannot be measured. However, it should be infinite with the battery disconnected. A low reading indicates a short.
6. The CAN B bus can become active from inputs or from the ignition switch.
7. Normal CAN C bus termination is 60 ohms. However, if other modules on the CAN C bus network have termination resistance then the actual reading on an ohmmeter will be less than 60 ohms.
8. Normal diagnostic CAN C termination is 60 ohms.
9. A normal voltmeter reading on the CAN C (+) circuit with the ignition key in the RUN position is about 2.60 volts.
10. A normal voltmeter reading on the CAN C (-) circuit with the ignition key in the RUN position is about 2.4 volts.
11. The CAN C bus may be either event driven or be active only with the ignition in the RUN position.
12. The wires must be twisted at a rate of one twist every inch (25.4 mm).

**Classroom  
Manual**

Chapter 11, page 297



**SPECIAL TOOLS**

Scan tool  
DMM  
Lab scope

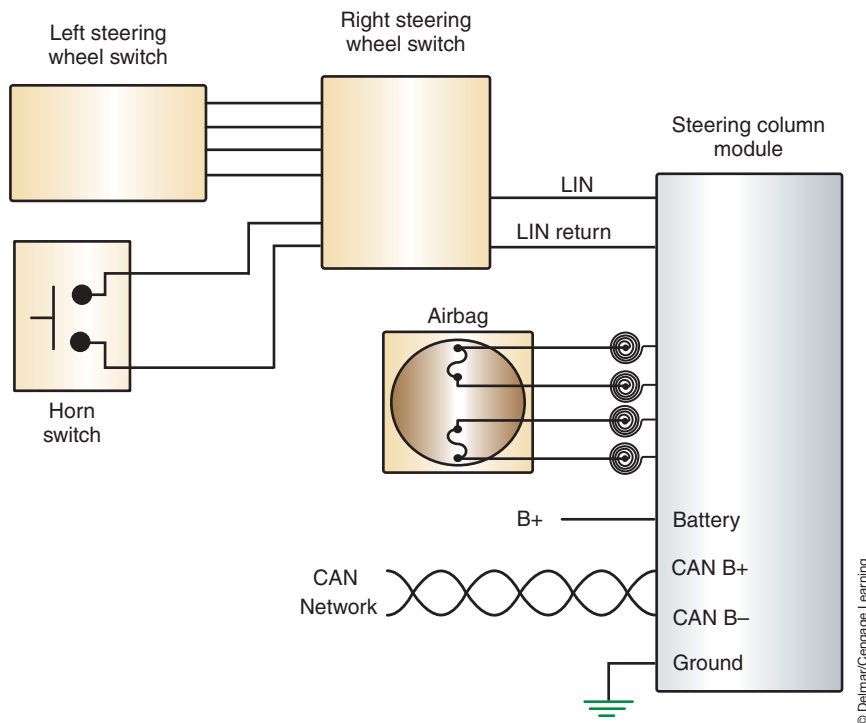
## LOCAL INTERCONNECT NETWORK BUS DIAGNOSTICS

The local interconnect network (LIN) bus is a supplemental bus network that is used along with the vehicle's main multiplexing system. The master module communicates data from the slave modules onto the main bus network. The scan tool will not have access to the slave module. All diagnostics with the scan tool are performed through the master module.

Figure 11-12 is an illustration of a LIN bus system used for steering wheel-mounted radio controls. The steering column module (SCM) is the master module and is also connected to the CAN B bus network. The right steering wheel switch assembly is actually the slave module and is capable of sending data to the SCM and of receiving data from the SCM. The left steering wheel switch is a multiplex switch system that uses different resistance values for each switch position. The different resistances result in a unique voltage drop that is sensed by the slave module. The request action of the driver that is indicated by pressing a switch is received by the slave module and sent to the master module. The master module then puts the data onto the CAN B bus network, and the message is sent to the radio, which performs the requested action.

In this example, the scan tool will communicate with the SCM. By observing the data display information on the scan tool, each switch position input should be indicated. In addition, the master module (the SCM in this case) will store a DTC if a system indicates a fault. For example, if a switch in the left steering wheel switch assembly indicates that it is stuck in the pressed position for an excessive amount of time, the SCM will set a DTC for this condition.

If a customer states that the steering wheel radio controls fail to operate, use the scan tool to see if any of the button pushes are indicated by the master module. If any are indicated,

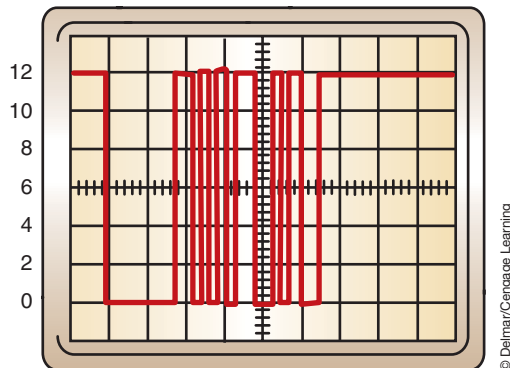


**FIGURE 11-12** LIN bus system used for remote radio controls mounted on the steering wheel.

then the LIN bus circuit is working. If none of the switch inputs are indicated on the scan tool, then the LIN bus circuit, the slave module, or the master module has failed.

Normal voltages on the LIN bus is up to 12 volts, which is pulled low during communications (Figure 11-13). However, if the slave module is disconnected from the master module and the LIN bus circuit is tested with a voltmeter with the ignition switch in the RUN position, the reading will be about 9.5 volts. This is due to the master module pulse width modulating the signal in an attempt to communicate with the slave module. The voltmeter is indicating an average reading. If the slave module is plugged in and the voltage is tested, the reading will now be about 8.3 volts since both modules are pulling the circuit low in an attempt to communicate. The most accurate way of determining LIN bus voltages is with a lab scope.

If zero volts are indicated by the voltmeter or lab scope when the slave module is disconnected, the cause could be a faulty master module, an open circuit between the master and



**FIGURE 11-13** Normal LIN bus trace.

slave module connector, or a short to ground in the LIN circuit. Use the voltmeter and ohmmeter to diagnose and locate the fault.

If normal voltage is indicated with the slave module disconnected, but then reads zero volts when it is reconnected, the fault is the slave module. In this case the slave module has an internal short to ground.

**CUSTOMER CARE:** Many people do not realize the subjectivity of the communication networks to RFI and EMI. These signals may interfere with module communications. If the customer says he is experiencing intermittent problems with the vehicle, it is possible the problem is due to an add-on feature such as a radio, cell phone, entertainment system, and so on. If this is found to be the problem, inform the customer that these systems may require special shielding and location alterations in order to prevent future instances.

## ENHANCED SCAN TOOL DIAGNOSTICS

Some scan tools provide enhanced diagnostics of the CAN bus networks. In addition to performing the module scan, these units may provide advanced loss of communication screens, network topology screens, and so on. All of these additional features are designed to assist the technician in diagnosing the CAN bus network. Photo Sequence 20 provides an example of these features and how they are accessed. Since scan tool manufacturers differ in their approach to diagnostics and display of information, this Photo Sequence is provided as a guide only. Always refer to the instructions for the scan tool you are using.

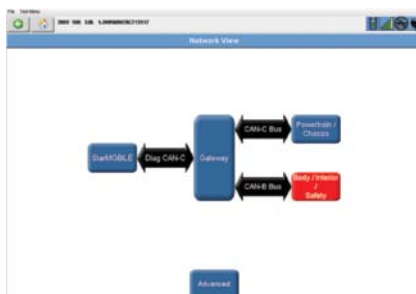
# PHOTO SEQUENCE 20

## ADVANCED SCAN TOOL FUNCTIONS

All photos in this sequence are © Delmar/Cengage Learning.



**P20-1** The “Home” screen of the scan tool. Select “Network View.”



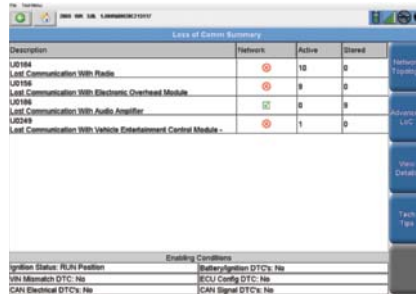
**P20-2** The network view provides an icon look of the CAN bus network from the scan tool to the different bus systems. Red-colored icons indicate a fault has been recorder in that system. From this screen select the “Advanced” button.

Description	Networks	Active	Stored	
U0184 Last Communication With Radio	10	0	0	Network Topology
U0186 Last Communication With Electronic Overhead Module	9	0	0	Advanced LUG
U0190 Last Communication With Audio Amplifier	0	0	0	View Details
U0249 Last Communication With Vehicle Entertainment Control Module	1	0	0	Test Tool

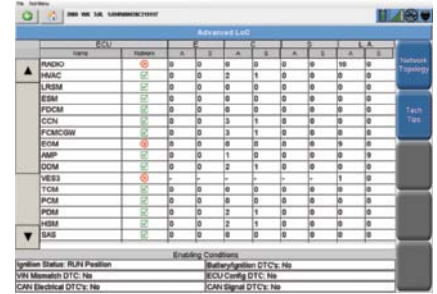
**P20-3** This is the Loss of Communications Summary screen. A green check mark indicates that the module is communicating with the scan tool. The red Xs indicates that those modules are not communicating on the network bus. Under the “Active” column, the “6” indicates that six other modules have logged loss of communication fault codes against the module and the faults are currently present. If any logged against faults were stored, they would be under the “Stored” column. Press the “Network Topology” button.



**P20-4** This is a “live” layout of the vehicle’s communication system. The color codes indicate if the module is active on the bus, if the vehicle is not built with that module, and the different bus networks. This is an actual representation of the vehicle’s communication wiring. The red icons indicate modules that are not communicating. In this case, a common connector or splice is not the cause of the problem. The next logical diagnostic step would be to see if the two affected modules share a common power circuit or ground.



**P20-5** Another option from the “Loss of Communication” screen is to press the “Advanced LoC” button. This takes the technician to another loss of communications screen.



**P20-6** This advanced loss of communications screen indicates the type of fault code as “E” for electrical, “C” for communications, “S” for implausible signal, and “L.A.” for logged against. Also columns indicate the number of active or stored codes and which modules have logged the fault.

## CASE STUDY

A customer has had his vehicle towed to the repair facility. Other shops have attempted to repair the problem of an intermittent no-start condition, but the problem persists. The technician attempts to duplicate the problem, but the engine will now start and run fine. The technician connects the scan tool and accesses the PCM to read fault codes. There are no active or stored DTCs. Realizing that the vehicle he is working on is equipped with the CAN bus network, he accesses the central gateway module to see if it has any DTCs stored in it. Here he finds a stored “Loss of communication with PCM” fault. There are no active

faults. Realizing that this is an intermittent problem, he checks the connectors at the PCM. Here he finds a loose terminal and makes the necessary repairs. The intermittent no-start was due to the vehicle’s security system not being able to communicate with the PCM; thus the PCM would not allow the engine to start. No fault codes were set in the PCM since it was doing what it was supposed to. Other modules did log the loss of communication fault against the PCM, since they could not communicate with the PCM when the terminal connection came loose.

## TERMS TO KNOW

- B-codes
- J1962 breakout box (BOB)
- U-codes
- Vehicle module scan

## ASE-STYLE REVIEW QUESTIONS

- In a J1850 VPWM bus system, how can a short to ground be isolated?
  - Use a jumper wire to supply battery voltage to pin 2 of the DLC while observing the DMM.
  - Disconnect in-line connectors one at a time while observing the DMM.
  - Use a jumper wire to short pin 15 of the DLC to ground while observing the DMM.
  - All of the above.
- If one of the CAN C bus circuits were shorted to ground, all of the following could occur EXCEPT:
  - No-start.
  - No communication between scan tool and any CAN C modules.
  - CGW module logs a loss of communication fault code against CAN C modules.
  - The bus will operate in single-wire mode.
- All of the following can cause total bus failure of the J1850 VPWM bus system, EXCEPT:
  - Open bus wire to the BCM.
  - Bus wire shorted to ground.
  - Bus wire shorted to battery voltage.
  - Internal short in a module.
- The lab scope trace of an ISO-K bus system shows the voltage going to  $-0.5$  volts. This would indicate:
  - The scan tool bias voltage.
  - The module attempting to transmit data to the scan tool.
  - The scan tool attempting to transmit data to the module.
  - Excessive electrical noise on the circuit.
- A class A bus that has zero volts on both bus circuits may indicate:
  - Both circuits are shorted to ground.
  - The master module's power feed circuit is open.
  - An open bus connector to the master module.
  - All of the above.
- To isolate a bus circuit that is shorted to battery voltage, all of the following methods can be used EXCEPT:
  - Use a jumper wire and connect the faulty circuit to ground.
  - Turn the ignition switch off to see if it is switched voltage.
  - Pull fuses one at a time to determine the shorted circuit.
  - Pull relays one at a time to determine shorted circuits or components.
- On a LIN bus, zero volts are indicated on the bus circuit with the slave module disconnected. What is the LEAST likely cause?
  - An open circuit between the master module and the slave module connector.
  - A shorted circuit between the master module and the slave module connector.
  - Faulty master module.
  - Faulty slave module.
- Technician A* says on the LIN bus system the scan tool accesses the slave modules to display their data. *Technician B* says the LIN slave module can only send data to the master module. Who is correct?
  - A only
  - B only
  - Both A and B
  - Neither A nor B
- When the scan tool is connected, voltage on the K-line reads zero. *Technician A* says this means the circuit may be shorted to ground. *Technician B* says the scan tool may be faulty. Who is correct?
  - A only
  - B only
  - Both A and B
  - Neither A nor B
- Technician A* says normal voltages on the LIN bus is up to 12 volts. *Technician B* says 12 volts on the LIN bus indicates data transmission. Who is correct?
  - A only
  - B only
  - Both A and B
  - Neither A nor B



## ASE CHALLENGE QUESTIONS

---

- Technician A* says on a CAN B system that if one of the bus circuits is shorted to ground, it may be possible to locate the fault by jumping battery voltage to the faulty circuit.

*Technician B* says to locate the short to ground, use a jumper wire and ground the opposite circuit.

Who is correct?

A. A only                      C. Both A and B  
B. B only                      D. Neither A nor B
- Technician A* says on an ISO 9141-2 bus system, without the scan tool connected, there should be voltage only on the L-line.

*Technician B* says the module supplies the voltage on the L-line.

Who is correct?

A. A only                      C. Both A and B  
B. B only                      D. Neither A nor B
- Technician A* says on CAN B bus systems it may be possible for the bus to operate if there is an electrical potential between one of the circuits and ground.

*Technician B* says if the two CAN B circuits are shorted together, total bus failure will result.

Who is correct?

A. A only                      C. Both A and B  
B. B only                      D. Neither A nor B
- One module fails to communicate on the bus.

*Technician A* says this can be due to an internal short of one of the bus circuits.

*Technician B* says this could be due to the module ground circuit being faulty.

Who is correct?

A. A only                      C. Both A and B  
B. B only                      D. Neither A nor B
- Technician A* says U-codes identify a failure with a body system function.

*Technician B* says B-codes are set to indicate bus network communication failures.

Who is correct?

A. A only                      C. Both A and B  
B. B only                      D. Neither A nor B

*This page intentionally left blank*

Name \_\_\_\_\_ Date \_\_\_\_\_

## ISO 9141-2 BUS SYSTEM DIAGNOSIS

Upon completion of this job sheet, you will be able to determine normal ISO 9141-2 bus operation. You will also observe faulty bus system operation.

### ASE Correlation

This job sheet is related to the ASE Electrical/Electronic System Certification Exam's content area: *Accessories Diagnosis and Repair*; task: Check for module communication errors using a scan tool.

### Tools and Materials

J1962 BOB

Scan tool

DMM

Lab scope

Jumper wires

Service information

Vehicle with an ISO 9141-2 bus system

### Describe the vehicle being worked on:

Year: \_\_\_\_\_ Make: \_\_\_\_\_ Model: \_\_\_\_\_

VIN: \_\_\_\_\_ Engine type and size: \_\_\_\_\_

### Procedure

---

 Task Completed

#### Task 1

- Use the service information to identify DLC cavities assigned to the ISO 9141-2 circuits. These circuits are usually referred to as the K-line and the L-line.

#### a. K-line

Cavity number \_\_\_\_\_

Circuit identification \_\_\_\_\_

Color code \_\_\_\_\_

#### b. L-line

Cavity number \_\_\_\_\_

Circuit identification \_\_\_\_\_

Color code \_\_\_\_\_

- Connect the J1962 BOB to the DLC. Use the voltmeter function of the DMM to measure the voltage on each bus circuit without a scan tool connected to the DLC.

K-line \_\_\_\_\_

L-line \_\_\_\_\_

---

**Task Completed**

3. Connect the scan tool to the DLC and observe and record the voltages for each bus circuit.  
K-line \_\_\_\_\_  
L-line \_\_\_\_\_
4. Establish communications between the scan tool and the PCM and record the voltages on each bus circuit.  
K-line \_\_\_\_\_  
L-line \_\_\_\_\_
5. Remove the scan tool from the DLC and use a lab scope to trace the voltage on each bus circuit with the ignition switch in the OFF position. If available, use the print function to print the trace for each circuit. If not available, describe what was observed.  
K-line \_\_\_\_\_  
L-line \_\_\_\_\_
6. Connect the scan tool, and with the ignition switch in the OFF position, use a lab scope to trace the voltage on each bus circuit. If available, use the print function to print the trace for each circuit. If not available, describe what was observed.  
K-line \_\_\_\_\_  
L-line \_\_\_\_\_
7. Turn the ignition switch to the RUN position, and use a lab scope to trace the voltage on each bus circuit. If available, use the print function to print the trace for each circuit. If not available, describe what was observed.  
K-line \_\_\_\_\_  
L-line \_\_\_\_\_
8. Establish communications between the scan tool and the PCM while observing the lab scope trace. If available, use the print function to print the trace for each circuit. If not available, describe what was observed.  
K-line \_\_\_\_\_  
L-line \_\_\_\_\_
9. Based on your observations of normal bus operation, what can you conclude concerning normal voltage?  
\_\_\_\_\_  
\_\_\_\_\_  
\_\_\_\_\_

**Task 2**

1. Use a jumper wire and short the K-line from the J1962 BOB to chassis ground.
2. Connect the scan tool, and turn the ignition switch to the RUN position; attempt to establish communications with the PCM. Record the results.

---

---

3. Use a lab scope to trace the voltages on both circuits. If available, use the print function to print the trace for each circuit. If not available, describe what was observed.

K-line \_\_\_\_\_

L-line \_\_\_\_\_

4. Based on your observations, what is the effect of the short to ground?

\_\_\_\_\_

\_\_\_\_\_

Instructor's Response \_\_\_\_\_

\_\_\_\_\_

\_\_\_\_\_

*This page intentionally left blank*



Name \_\_\_\_\_ Date \_\_\_\_\_

## ISO-K BUS SYSTEM DIAGNOSIS

Upon completion of this job sheet, you will identify normal operating characteristics of the ISO-K bus using a lab scope and a scan tool.

### ASE Correlation

This job sheet is related to the ASE Electrical/Electronic System Certification Exam’s content area: *Accessories Diagnosis and Repair*; task: Check for module communication errors using a scan tool.

### Tools and Materials

- J1962 BOB
- Scan tool
- DMM
- Lab scope
- Jumper wires
- Service information
- Vehicle with an ISO-K bus system

### Describe the vehicle being worked on:

Year: \_\_\_\_\_ Make: \_\_\_\_\_ Model: \_\_\_\_\_  
 VIN: \_\_\_\_\_ Engine type and size: \_\_\_\_\_

### Procedure

\_\_\_\_\_ Task Completed

1. Use the service information to identify DLC cavity assigned to the ISO-K circuit to the PCM.
  - a. K-line
    - Cavity number \_\_\_\_\_
    - Circuit identification \_\_\_\_\_
    - Color code \_\_\_\_\_
  
2. Connect the J1962 BOB to the DLC. Use a lab scope to trace the voltage on the K-line with the ignition switch in the OFF position. If available, use the print function to print the trace for the K-line circuit. If not available, describe what was observed.
 

\_\_\_\_\_
  
3. Connect the scan tool, and with the ignition switch in the OFF position, use a lab scope to trace the voltage on the K-line. If available, use the print function to print the trace for the K-line circuit. If not available, describe what was observed.
 

\_\_\_\_\_

4. With the ignition switch still in the OFF position, attempt to communicate with the PCM. Use a lab scope to trace the voltage on the K-line. If available, use the print function to print the trace for the K-line circuit. If not available, describe what was observed.

---

5. Turn the ignition switch to the RUN position. Establish communications between the scan tool and the PCM while observing the lab scope trace. If available, use the print function to print the trace for the K-line circuit. If not available, describe what was observed.

---

6. What is indicated by each of the voltage values seen on the trace?

---

---

---

Instructor's Response: \_\_\_\_\_

---

---

Name \_\_\_\_\_ Date \_\_\_\_\_

## J1850 BUS SYSTEM DIAGNOSIS

Upon completion of this job sheet, you will be able to use the scan tool and a DMM to monitor normal J1850 bus activity. You will also use the lab scope to observe normal bus operation. Finally, you will use the DMM to diagnose full and partial failures of the J1850 bus.

### ASE Correlation

This job sheet is related to the ASE Electrical/Electronic System Certification Exam's content area: *Accessories Diagnosis and Repair*; task: Check for module communication errors using a scan tool.

### Tools and Materials

- J1962 BOB
- Scan tool
- DMM
- Lab scope
- Jumper wires
- Service information
- Vehicle with J18050 bus
- Instructor-installed bugs

### Describe the vehicle being worked on:

Year: \_\_\_\_\_ Make: \_\_\_\_\_ Model: \_\_\_\_\_  
 VIN: \_\_\_\_\_ Engine type and size: \_\_\_\_\_

### Procedure

Task Completed

#### Task 1

1. Use the service information to identify the DLC cavity number(s), circuit identification, and color code(s). Record your findings.
  - a. Cavity number(s) \_\_\_\_\_
  - b. Circuit identification \_\_\_\_\_
  - c. Color code(s) \_\_\_\_\_
2. Connect the J 1962 BOB to the DLC, and connect the scan tool to the J1962 BOB. Turn the ignition switch to the RUN position. □
3. If available, use the scan tool to perform an 1850 module scan. List all active modules on the J1850 bus.

---



---



---



---

**Task Completed**

4. Does the J1850 bus appear to be operating normally?  Yes  No

Explain your answer:

---

---

5. Connect the DMM positive lead to the J1850 bus circuit of the J 1962 BOB (a jumper wire may be required). Connect the negative lead to a good chassis ground. With the DMM set to read DC volts, observe and record the voltage range:

MIN \_\_\_\_\_ MAX \_\_\_\_\_

6. Remove the DMM, and use a lab scope to observe the J1850 bus activity. If available, use the print function to print off the trace. If not available, describe the lab scope display:

---

---

---

7. Turn the ignition switch to the OFF position, and disconnect the vehicle battery.

8. Use the ohmmeter function of the DMM to measure the resistance between the J1962 BOB cavity for the J1850 bus and chassis ground. Observe and record the J1850 bus termination resistance. \_\_\_\_\_

9. Disconnect a regular node from the J1850 bus and record the bus termination resistance. \_\_\_\_\_

10. Disconnect the scan tool from the J1850 bus and record the bus termination resistance. \_\_\_\_\_

11. Disconnect the PCM from the J1850 bus and record the bus termination resistance. \_\_\_\_\_

12. Based on your observations, are the nodes wired in series or parallel? \_\_\_\_\_

13. Based on your observations, which module had the greatest impact on bus terminal resistance and why?

---

---

14. Reconnect all modules and then reconnect the vehicle battery.

**Task 2**

1. Start the engine, and use a jumper wire to short the J1850 bus circuit of the J1962 BOB to chassis ground. What are the observable conditions?

---

---

---

2. Using the scan tool, perform a J1850 module scan and record the results.

---

3. Use the voltmeter function of the DMM to observe and record the J1850 bus voltage.

---

4. Does the measured voltage indicate normal operation?  Yes  No

5. Turn the ignition switch to the OFF position, and disconnect the vehicle battery.

6. Use the ohmmeter function of the DMM; observe and record the J1850 bus termination resistance. \_\_\_\_\_

7. Explain the difference in this reading compared to task 1, step 11.

---

---

---

8. Remove the jumper wire used to short the bus to ground and reconnect the vehicle battery.

9. With the engine running, use a jumper wire to short the J1850 bus circuit of the J1962 BOB to battery voltage. What are the observable conditions?

---

---

---

10. Use the scan tool to perform a J1850 module scan and record the results.

---

---

11. Use the voltmeter function of the DMM; observe and record the J1850 bus voltage.

---

12. Turn the ignition switch to the OFF position. Observe and record the J1850 bus voltage. \_\_\_\_\_

13. If the voltage changed between step 11 and step 12, what does this indicate?

---

---

14. Based on your observations, can the J1850 bus be diagnosed with a DMM?

Yes  No

Explain your answer.

---

---

### Task 3

1. A vehicle is brought to the shop with inoperative gauges and several electrical accessories not functioning properly

Can the condition be verified?  Yes  No

2. Use the scan tool to perform a J1850 module scan. Are there any modules present?  Yes  No

3. Disconnect the scan tool. With the ignition switch in the RUN position, use the J1962 BOB and the voltmeter function of the DMM to measure and record the J1850 bus voltage. \_\_\_\_\_

Is the voltage within normal limits?  Yes  No

4. What does the voltmeter reading indicate?

---

---

5. Turn the ignition switch to the OFF position, and measure and record the J1850 bus voltage at the BOB.

---

6. What conclusions, if any, can be made at this time?

---

---

---

7. While the voltmeter is reading the indicated voltage of step 3, monitor the voltage while removing fuses from the power distribution center and junction box one at a time. Which fuses, when removed, caused a change in bus voltage?

---

8. Use the service information to determine which circuits or systems are implicated by the fuses removed in step 7.

---

9. At the vehicle, isolate the implicated components one at a time by disconnecting them and observing the voltmeter readings. Does isolating the component correct the problem?  Yes  No

If yes, identify the faulty component.

---

If no, what is the next step?

---

10. If the answer to step 9 was no, perform the tests you indicated that still need to be done. Was the root cause of the fault able to be determined?  Yes  No  
If yes, describe the fault.

---

If no, consult with your instructor.

---

#### Task 4

1. Your instructor will inform you of the customer complaint. Record the problem.

---

---

2. Can the problem be verified?  Yes  No

3. Use the scan tool to communicate with the module(s) that operate the faulty system. Are communications with the module possible?  Yes  No

If yes, record any DTCs that are present.

---

---



If no, perform a J1850 module scan and record your results.

---

---

4. What problems are indicated?

---

---

5. Based on these observations and your understanding of J1850 bus operation, what is the next logical step?

---

---

6. Based on your answer to step 5, assemble the necessary information needed to diagnose the fault. Record this information.

---

---

---

7. Based on the information gathered, return to the vehicle and determine the cause of the fault. What is the necessary repair action?

---

---

---

Instructor's Response \_\_\_\_\_

---

---

*This page intentionally left blank*

Name \_\_\_\_\_ Date \_\_\_\_\_

## CAN BUS SYSTEM DIAGNOSIS

Upon completion of this job sheet, you will be able to identify the circuits that make up the CAN bus and determine their operating characteristics.

### ASE Correlation

This job sheet is related to the ASE Electrical/Electronic System Certification Exam's content area: *Accessories Diagnosis and Repair*; task: Check for module communication errors using a scan tool.

### Tools and Materials

- J1962 BOB
- Scan tool
- DMM
- Lab scope
- Jumper wires
- Service information
- Vehicle with full vehicle CAN bus system

### Describe the vehicle being worked on:

Year: \_\_\_\_\_ Make: \_\_\_\_\_ Model: \_\_\_\_\_  
 VIN: \_\_\_\_\_ Engine type and size: \_\_\_\_\_

### Procedure

Task Completed \_\_\_\_\_

#### Task 1

1. Use the service information to identify the following CAN bus circuit numbers and color codes:

**NOTE:** The circuits may be called by other names than those listed here.

- a. CAN B (+) \_\_\_\_\_
  - b. CAN B (-) \_\_\_\_\_
  - c. CAN C (+) \_\_\_\_\_
  - d. CAN C (-) \_\_\_\_\_
  - e. Diagnostic CAN C (+) \_\_\_\_\_
  - f. Diagnostic CAN C (-) \_\_\_\_\_
2. Identify the cavity numbers the diagnostic CAN bus uses at the DLC.
    - a. Diagnostic CAN C (+) \_\_\_\_\_
    - b. Diagnostic CAN C (-) \_\_\_\_\_
  3. Identify the cavity numbers of a connector to a module on the CAN B bus network.
    - a. Module \_\_\_\_\_
      - i. CAN B (+) cavity \_\_\_\_\_
      - ii. CAN B (-) cavity \_\_\_\_\_

**Task Completed**

4. Identify the cavity numbers for the CAN C bus network at the PCM connector.
  - a. CAN B (+) \_\_\_\_\_
  - b. CAN B (-) \_\_\_\_\_
5. Using the service information information, determine the baud rate of each of the bus networks.
  - a. CAN B (+) \_\_\_\_\_
  - b. CAN B (-) \_\_\_\_\_
  - c. CAN C (+) \_\_\_\_\_
  - d. CAN C (-) \_\_\_\_\_
  - e. Diagnostic CAN C (+) \_\_\_\_\_
  - f. Diagnostic CAN C (-) \_\_\_\_\_

**Task 2**

1. Locate the CAN B module from task 1, step 3 on the vehicle. With the ignition switch in the RUN position, use probing tools to connect the voltmeter leads to the CAN B (+) circuit and chassis ground. Record your reading. \_\_\_\_\_
  2. Read the voltage on the CAN B (-) circuit with the ignition switch in the RUN position. \_\_\_\_\_
  3. Turn the ignition switch to the OFF position, and close all doors so the bus can power down. While the bus is powering down, record the voltages on each circuit.
    - a. CAN B (+) \_\_\_\_\_
    - b. CAN B (-) \_\_\_\_\_
  4. Leave the ignition switch in the OFF position, and open a door. Record the bus voltages now.
    - a. CAN B (+) \_\_\_\_\_
    - b. CAN B (-) \_\_\_\_\_
  5. Based on your observations, what is required to activate the CAN B bus network?  
\_\_\_\_\_
6. Turn the ignition switch to the OFF position and disconnect the vehicle battery.
7. Measure the resistance between the two CAN B bus circuits. \_\_\_\_\_  
Explain your results. \_\_\_\_\_  
\_\_\_\_\_

**Task 3**

1. Connect the J1962 BOB to the DLC, and turn the ignition switch to the RUN position. Use the scan tool to determine which modules on the vehicle are on the CAN B bus and record them.  
\_\_\_\_\_  
\_\_\_\_\_  
\_\_\_\_\_
2. Access the CAN B module connector from task 1, step 3, and use a jumper wire to short one of the CAN B bus circuits to ground. Use the scan tool to determine which modules are active on the CAN B bus network.  
\_\_\_\_\_  
\_\_\_\_\_  
\_\_\_\_\_

3. Using a jumper wire and a probing tool, short both CAN B bus circuits together. Use the scan tool to determine which modules are active on the CAN B bus network.

---

---

---

4. Using a jumper wire and a probing tool, short both CAN B bus circuits to ground. Use the scan tool to determine which modules are active on the CAN B bus network.

---

---

---

5. Use the scan tool and access the central gateway module. Record any fault codes listed.

---

---

---

6. Remove the short from the bus circuit

7. Based on your observations, is this bus network fault tolerant?  Yes  No

Explain your results.

---

---

#### Task 4

1. Use the scan tool to identify the modules that are on the CAN C bus network and record them.

---

---

---

2. Locate the PCM connector identified in task 1, and disconnect it from the PCM. Use a jumper wire and a probing tool to short one of the CAN C bus circuits to chassis ground.

3. Use the scan tool and attempt to establish communications with any of the modules identified in step 1 (except the PCM). Is communication possible?  Yes  No

Explain your results. \_\_\_\_\_

---

4. Use a jumper wire and a probing tool to short both of the CAN C bus circuits together. Use the scan tool and attempt to establish communications with any of the modules identified in step 1 (except the PCM). Is communication possible?  Yes  No

Explain your results. \_\_\_\_\_

---

5. Based on your observations, is this bus network fault tolerant?  Yes  No

Explain your results.

---

---

6. Remove all faults, but leave the PCM connector unplugged.

**Task 5**

1. Remove the scan tool from the DLC. Use a probing tool and the voltmeter function of the DMM to obtain and record the CAN C bus voltages during the following conditions.
  - a. Ignition switch in RUN position.    CAN C (+) \_\_\_\_\_    CAN C (-) \_\_\_\_\_
  - b. Ignition switch in OFF position.    CAN C (+) \_\_\_\_\_    CAN C (-) \_\_\_\_\_
  - c. Ignition switch in OFF position and CAN B bus powered down.  
CAN C (+) \_\_\_\_\_ CAN C (-) \_\_\_\_\_
  - d. Ignition switch in OFF position; open a door.  
CAN C (+) \_\_\_\_\_ CAN C (-) \_\_\_\_\_

2. Based on your observations, what is required to activate the CAN C bus network?  
\_\_\_\_\_

3. Turn the ignition switch to the OFF position and disconnect the vehicle battery.

4. Measure the resistance between the two CAN C bus circuits. \_\_\_\_\_  
Explain your results. \_\_\_\_\_

5. Reconnect all connectors.

**Task 6**

1. Connect the scan tool to the J1962 BOB and the DLC. Use a jumper wire to short one of the diagnostic CAN C bus circuits at the BOB to ground. Attempt to communicate with the PCM. Was communication possible?  
 Yes     No

2. Remove the short, and move the jumper wire to short the other diagnostic CAN C bus circuit to ground. Attempt to communicate with the PCM. Was communication possible?  
 Yes     No

3. Use a jumper wire to short the two diagnostic CAN C bus circuits together. Attempt to communicate with the PCM. Was communication possible?  
 Yes     No

4. Based on your observations, what is your conclusion?  
\_\_\_\_\_  
\_\_\_\_\_  
\_\_\_\_\_

5. Turn the ignition switch to the OFF position, and disconnect the vehicle battery.

6. Measure the resistance between the two diagnostic CAN C bus circuits. \_\_\_\_\_  
Explain your results. \_\_\_\_\_

Instructor's Response \_\_\_\_\_  
\_\_\_\_\_  
\_\_\_\_\_



Name \_\_\_\_\_ Date \_\_\_\_\_

## LIN BUS SYSTEM DIAGNOSIS

Upon completion of this job sheet, you will be able to determine normal LIN bus operation. You will also observe faulty bus system operation.

### ASE Correlation

This job sheet is related to the ASE Electrical/Electronic System Certification Exam's content area: *Accessories Diagnosis and Repair*; task: Check for module communication errors using a scan tool.

### Tools and Materials

- Scan tool
- DMM
- Lab scope
- Jumper wires
- Service information
- Vehicle with LIN bus system

### Describe the vehicle being worked on:

Year: \_\_\_\_\_ Make: \_\_\_\_\_ Model: \_\_\_\_\_  
 VIN: \_\_\_\_\_ Engine type and size: \_\_\_\_\_

### Procedure

Task Completed \_\_\_\_\_

1. Use the service information to identify the function(s) of the LIN bus(es) on the assigned vehicle.

\_\_\_\_\_

\_\_\_\_\_

\_\_\_\_\_

2. Identify the LIN bus cavities of the master module.

\_\_\_\_\_

\_\_\_\_\_

\_\_\_\_\_

3. Identify the LIN bus cavities of the slave module.

\_\_\_\_\_

\_\_\_\_\_

\_\_\_\_\_

4. Does the slave module have any inputs to it from other sources?  Yes  No

If yes, list them.

\_\_\_\_\_

\_\_\_\_\_

---

Task Completed

5. With the ignition switch in the RUN position, connect the scan tool and navigate to the master module. Are any items available in the data display to assist in diagnosing a system failure?  Yes  No

If yes, list them.

---

---

6. Press and release any switch inputs that were identified while observing the scan tool. Do the switch states change on the scan tool?  Yes  No

7. Press and hold one of the switch buttons for a minimum of 60 seconds, and then release. Check and record any DTCs.

---

---

8. Is the DTC active or stored? \_\_\_\_\_

- a. If active, press and release the same button again. Did it change to stored now?  
 Yes  No

9. Disconnect the electrical connector to a switch input to the slave module. Check and record any DTCs.

---

---

10. If no DTCs were set, why not?

---

---

11. Press and release another switch input to the slave module while observing the scan tool. Does the scan tool indicate the switch presses?  Yes  No

12. Explain your results.

---

---

13. With the slave module still disconnected, use the voltmeter function of the DMM to measure the voltage on the LIN bus. \_\_\_\_\_

14. Reconnect the slave module and record the voltage on the LIN bus. \_\_\_\_\_

15. Are the voltages the same?  Yes  No

If no, explain.

---

---

16. Use a lab scope to observe the trace of the LIN bus voltages. Describe what is observed.

---

---

17. Short the LIN bus circuit to ground by back probing the slave module connector and using a jumper wire connected to a chassis ground. Check and record any DTCs.

---

---

**18. Caution: Verify circuit identification before performing this step or vehicle damage could occur.**

Short the LIN bus circuit to power by back probing the right steering wheel switch connector; use a fused jumper wire connected to vehicle power. Check and record any DTCs.

---

---

**19. Record your conclusions.**

---

---

---

Instructor's Response \_\_\_\_\_

---

---

<b>DIAGNOSTIC CHART 11-1</b>	
PROBLEM AREA:	Vehicle communication systems
SYMPTOMS:	Scan tool cannot communicate with a module
POSSIBLE CAUSES:	<ol style="list-style-type: none"> <li>1. Faulty battery feed circuit to module</li> <li>2. Faulty ignition feed circuit to module</li> <li>3. Poor module ground</li> <li>4. Open data bus circuit to module</li> </ol>

<b>DIAGNOSTIC CHART 11-2</b>	
PROBLEM AREA:	Vehicle communication systems
SYMPTOMS:	Scan tool cannot communicate with any module
POSSIBLE CAUSES:	<ol style="list-style-type: none"> <li>1. Open bus circuit at DLC</li> <li>2. Bus circuit shorted to ground</li> <li>3. Bus circuit shorted to voltage</li> <li>4. Internal failure in a module causing short to power</li> <li>5. Internal failure in a module causing short to ground</li> <li>6. Open termination resistors</li> <li>7. Faulty scan tool</li> </ol>

<b>DIAGNOSTIC CHART 11-3</b>	
PROBLEM AREA:	Vehicle communication systems
SYMPTOMS:	Total bus failure indicated by default conditions and possible no-start
POSSIBLE CAUSES:	<ol style="list-style-type: none"> <li>1. Open bus circuit at DLC</li> <li>2. Bus circuit shorted to ground</li> <li>3. Bus circuit shorted to voltage</li> <li>4. Internal failure in a module causing short to power</li> <li>5. Internal failure in a module causing short to ground</li> <li>6. Open termination resistors</li> </ol>

## ADVANCED LIGHTING SYSTEMS DIAGNOSIS AND SERVICE



### BASIC TOOLS

Basic mechanic's tool kit  
Service information

### UPON COMPLETION AND REVIEW OF THIS CHAPTER, YOU SHOULD BE ABLE TO:

- Diagnose computer-controlled concealed headlight systems.
- Perform a functional test of the automatic headlight system.
- Diagnose the automatic headlight system.
- Test the automatic headlight system's photocell.
- Replace the photocell assembly.
- Test the automatic headlight system's amplifier.
- Diagnose Ford's illuminated entry system as an example of control module systems.
- Diagnose Chrysler's illuminated entry system as an example of BCM-controlled systems.
- Diagnose fiber optic systems.

### INTRODUCTION

Diagnosis of computer-controlled lighting systems is designed to be as easy as possible. The controller may provide trouble codes to assist the technician in diagnosis. Most manufacturers provide a detailed diagnostic chart for the most common symptoms. The most important thing to remember when diagnosing these systems is to follow the diagnostic procedures in order. Do not attempt to get ahead of the chart by assuming the outcome of a test. This will lead to replacement of good parts and lost time.

In this chapter, you will perform selected service samples on the computer-controlled concealed headlight, automatic headlight, and illuminated entry systems. It is out of the scope of this manual to provide service procedures for the different manufacturers that use these systems. Technicians must follow the procedure in the service information for the vehicle they are diagnosing.

The second section of this chapter covers diagnosis and service of electronic instrument panels.

### COMPUTER-CONTROLLED CONCEALED HEADLIGHT DIAGNOSIS

The body control module (BCM) has been utilized by some manufacturers to operate the concealed headlight system. The BCM will receive inputs from the headlight and flash-to-pass switches. The operation of the headlight door motor is controlled by relays that are energized by the BCM.

Customer complaints associated with the concealed headlight system may include:

1. Headlight doors will not open.
2. Headlight doors will not close.
3. Headlight doors will not open for flash-to-pass.
4. Headlight doors do not operate by headlight switch.
5. Headlights do not turn off.

**Classroom  
Manual**

Chapter 12, page 305

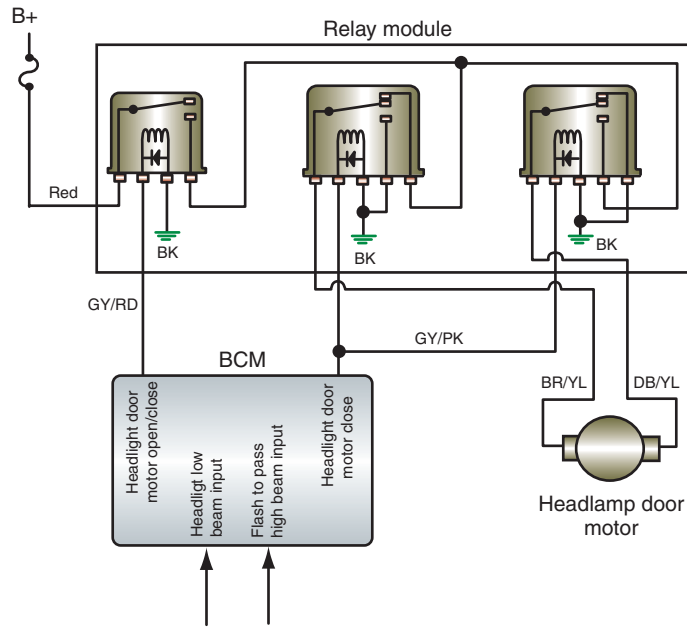


FIGURE 12-1 Concealed headlight door schematic.

© Delmar/Cengage Learning



## SPECIAL TOOLS

Scan tool  
DMM  
Jumper wires  
Fender covers  
Safety glasses  
Service information

The illustration (Figure 12-1) is a schematic of the concealed headlight system used on some Chrysler vehicles. Confirm the complaint by trying to operate the system. Once the complaint is confirmed, make a complete visual inspection of the system. Look for loose connections, broken wires, damaged components, and so on. If the visual inspection does not reveal an obvious fault, refer to the service information for the specific tests to be performed as determined by the symptom. Study the schematic of the system you are diagnosing until you understand how it is supposed to operate.

The following is a diagnostic service sample of a customer complaint that the headlight doors will not open. Always refer to the correct service procedures for the vehicle you are diagnosing.

Begin by using the scan tool to actuate the door motors. If the doors do not operate, go to step 1. If the doors operate, begin at step 4 of the following test procedure.



**WARNING:** Do not place your hands close to the headlight doors when the test is activated.

The exact method of getting to the headlight door test may vary depending on the year and scan tool.



## CAUTION:

If you forward probe a connector, be careful not to swell the terminal. Use the correct size tools or adaptors.

1. Check the relay fuse. A blown fuse indicates a possible problem in the circuit to the relay module and door motors. If the fuse is blown, go to step 2. If the fuse is not blown, go to step 3.
2. Disconnect the headlight door relay module and use an ohmmeter to measure the resistance between the connector red wire and ground. The resistance should be higher than 5 ohms. If it is not, there is a short to ground in the red wire. If the resistance is above 5 ohms, disconnect the headlight door connector and measure the resistance between the relay module connector DB/YL wire and ground.
  - If the resistance is lower than 5 ohms, the DB/YL wire has a short to ground between the relay module and the door motor.
  - If it is higher than 5 ohms, reconnect the relay module. Use a DMM to test for voltage across the headlight door motor connector. Voltage will be present for only a few seconds when the headlight switch is turned on. If the voltage is 10 volts or higher, replace the door motor. If it is less than 10 volts, replace the door relay module.



3. Use a voltmeter to test for applied voltage to the fuse. No voltage at this point indicates there is an open or short in the circuit between the battery and the fuse box. If there are more than 10 volts applied to the fuse box, disconnect the headlight door motor connector. Reinstall the fuse and use a DMM to measure the voltage across the connector terminals when the headlight switch is turned on. The voltage will be present for only a few seconds.
  - If the voltage is higher than 10 volts and a good ground is confirmed, replace the motor.
  - If the voltage is less than 10 volts, turn off the headlights and back probe the BR/YL wire at the relay module using the voltmeter. Voltage should be present for a few seconds when the headlight switch is turned on.
  - If the voltage is higher than 10 volts, there is an open in the BR/YL wire between the relay module and the motor.
  - If the voltage is less than 10 volts, back probe the RD wire at the relay module connection.
  - If the voltage is lower than 10 volts, there is an open in the RD wire between the relay module and the relay fuse.
  - If the voltage is over 10 volts, turn the ignition switch off and use an ohmmeter to test the resistance at the relay module connector BK wire. A resistance reading higher than 5 ohms means there is an open in the BK wire from the connector to ground. If it is lower than 5 ohms, connect a jumper wire from the battery positive terminal to the relay module GY/RD wire. The doors should open. If not, replace the relay module. If the doors open, test the circuit between the body controller and the relay module. If the circuit is good, replace the BCM.
4. If the doors operated properly when the scan tool performed the headlight door test, use the scan tool to access the switch test mode and select “headlight switch” from the menu.
5. While observing the scan tool, turn on the headlight switch. If the scan tool indicates the circuit is closed, replace the BCM.
6. If the scan tool displays that the circuit is open, disconnect the left POD switch connector. Use a jumper wire to connect the low beam input circuit terminal to ground.
7. Observe the scan tool. If it reads that the circuit is open, there is an open in the circuit between the POD and the BCM terminal. If a closed circuit is indicated, use an ohmmeter to measure the resistance to ground at the POD switch connector ground circuit.
  - If the resistance is lower than 5 ohms, replace the POD switch.
  - A reading higher than 5 ohms indicates an open in the circuit to ground.

The preceding procedure provided an example of testing a concealed headlight system. Regardless of the vehicle being worked on, the diagnosis is broken down into sections. The system uses inputs, a control module, and the actuators. By performing the door open actuator test, you can determine if the fault is isolated to the control module or the motor circuit. If the actuation test passes, then check the inputs that are used.

## TESTING COMPUTER-CONTROLLED HEADLIGHT SYSTEMS

A basic computer-controlled headlight system will use the headlight switch as an input to the BCM, which then activates the required relays to perform the requested function. The system may have separate relays for the park lights, fog lights, and headlights. The circuit operation for each of these relays is usually performed by low side drivers to complete the path to ground for the relay coil. The following will focus on testing the headlight system, although diagnostics for the park and fog light systems are similar.

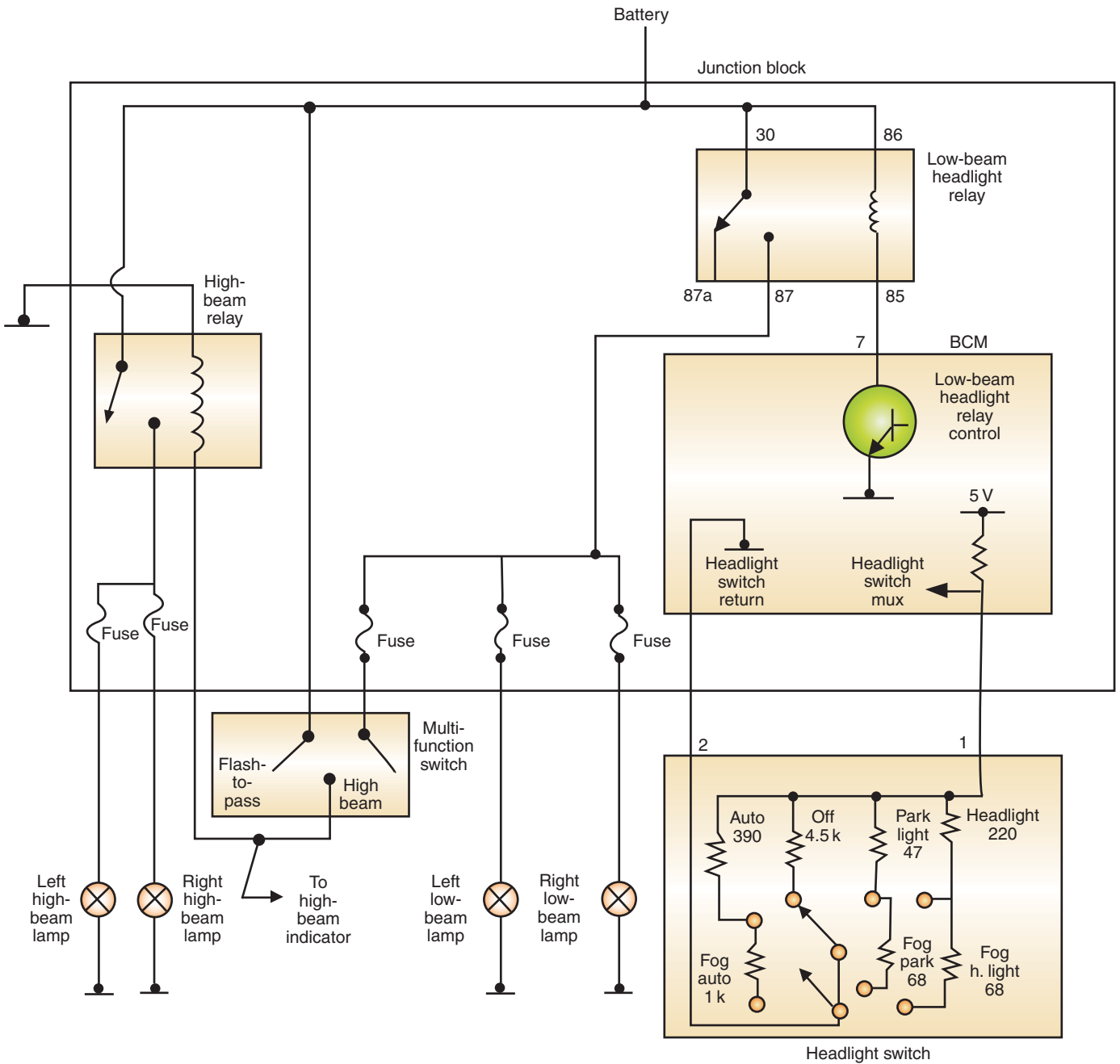


FIGURE 12-2 Schematic of a computer-controlled headlight system.

© Delmar/Cengage Learning



### SPECIAL TOOLS

- Scan tool
- DMM
- Fused jumper wires
- Test light

Using Figure 12-2 as a schematic of the system, we will go through the steps to diagnose a customer complaint that the headlights do not come on. Always refer to the proper wiring diagram for the vehicle you are working on. As with any electrical system problem, begin by confirming that the system is malfunctioning. Also, note any other systems that are not working properly. In the system shown, use the multifunction switch to activate the flash-to-pass feature. This will test the operation of the high-beam lights and relay.

Check any associated fuses and repair as needed. Next, conduct a visual inspection and repair any faults found. If the cause of the problem is not located, substitute the low-beam relay with a known good relay of the same type and test operation. If the system works now, the relay

was at fault and the repair is complete. If the system still does not work, begin testing the rest of the system.

If a scan tool is available, check to see if any DTCs have been set. If so, use the diagnostic chart for the DTC to locate the problem. If there are no DTCs (not all systems will set codes), use the scan tool to perform an activation test of the headlights. If the headlights work during the activation test, the problem is in the input side of the system. Use the scan tool to monitor the headlight switch while it is placed in all switch positions. Record the voltages for each position and compare to specifications. In this example, if 5 volts is displayed in all positions, there is an open in the circuit. The open could be in the wire between the BCM and the switch, in the switch itself, or in the ground circuit. Test each of these components with an ohmmeter. The switch is a resistive multiplex switch that should have a different resistance value for each switch position. With the switch disconnected, attach the ohmmeter across terminals 1 and 2 of the switch. Place the switch in each position and record the results. Check the results with the service information. If the values are out of range, replace the switch.

When testing the input signal with the scan tool, if the voltage displayed is 0 volts, this would indicate that the circuit is shorted to ground or a faulty BCM. Test the circuit for a short. If there are no shorts, check the voltage input and ground connections of the BCM. If these are good, replace the BCM.

If the headlights did not come on when the scan tool activated the system, the problem is in the relay control circuit, the BCM, the high-current circuit from the battery through the relay to the headlights, or in the headlight ground. To determine which circuit is at fault, remove the low-beam headlight relay. Use a voltmeter or test light to confirm battery voltage is present at pins 30 and 86 of the junction block terminals. If voltage is not present, there is an open or short between the junction block and the battery. If voltage is present at both pins, use a fused jumper wire to connect pin 30 to pin 87. If the lights come on now, the problem is in the control side circuit of the relay (the relay itself was tested earlier when it was substituted).

To test the control side circuit, connect a test light between pins 86 and 85 of the junction block terminals (relay removed). Place the headlight switch into the headlamp position and observe the test light. Since the BCM should now complete the path to ground, the test light should illuminate. If the test light fails to turn on, go to pin 7 of the BCM and back probe a jumper wire into the connector. Touch the other end of the fused jumper wire to a good ground. If the test light comes on, check the ground connections of the BCM. If the grounds are good, replace the BCM. If the test light still does not come on, there is an open in the circuit between pin 85 of the junction block and the BCM. In this case, the BCM attaches to the back of the junction block and the circuit wire is internal to the junction block. If this circuit is bad, the junction block will need to be replaced.

If the lights do not come on when the fused jumper wire is connected across pins 30 and 87 of the junction block, the problem is between the relay and the headlights. Connect a fused jumper wire from the battery positive post to the feed into one of the headlight's connectors. If the headlight illuminates, check the circuit from the junction block to the headlight. If the circuit is good, the problem is probably at the splice in the junction block and the junction block will need to be replaced. If the headlight still does not turn on, check the ground connections. If the grounds are good, the bulb is burned out. It is unlikely that both headlight bulbs will burn out at the same time unless there are other problems. If both bulbs are burned out, check the charging system for over voltage output. Also, use a lab scope connected to the battery positive post and ground to look for voltage spikes above the charging system's target voltage value. Voltage spikes may indicate that the battery connections are not clean (remember, the battery acts as a buffer), the battery is bad, or there is resistance on the charging system's sense circuit.



#### **SERVICE TIP:**

If a scan tool is not available, the input can be tested along with the control side of the relay by connecting a test light across terminal 85 and 86. If the test light comes on when the switch is placed in the headlamp position, the BCM is receiving the input and carrying out the command.



## SPECIAL TOOLS

Bright flashlight

## AUTOMATIC HEADLIGHT SYSTEM DIAGNOSIS

The automatic on/off with time delay has two functions: to turn on the headlights automatically when ambient light decreases to a predetermined level and to allow the headlights to remain on for a certain amount of time after the vehicle has been turned off (providing light for the passengers exiting the vehicle). This system can be used in combination with automatic dimming systems.

**The common components of the automatic on/off with time delay include:**

1. Photocell and amplifier.
2. Power relay.
3. Timer control that is a potentiometer incorporated into the headlight switch. The timer control unit controls the automatic operation of the system and the length of time the headlights stay on after the ignition switch is turned off.

In a typical system, a photocell is located inside the vehicle's dash to sense outside light. In most systems, the headlight switch must be in the OFF or AUTO position to activate the automatic mode.

If the headlights do not turn on, check the regular headlight system first before condemning the automatic headlight system. If the headlights do not illuminate when the automatic system is turned off, the problem is in the basic circuit.

To perform a "functional test" of the automatic headlight system, turn the headlight switch into the appropriate position to activate the automatic headlight function. Cover the photocell and start the engine. Some systems may be activated with the ignition switch in the RUN position; however, many systems are designed to delay turning on the headlights until an engine run signal is received. The headlights should turn on within 30 seconds. Remove the cover you placed over the photocell and shine a bright light onto it. The lights should turn off after 10 seconds but within 60 seconds. Cover the photocell again. When the lights turn on, wait 15 seconds. Then turn off the ignition switch. The headlights should turn off after the selected amount of time delay.

Once it is determined that the fault is within the automatic headlight system, make a few quick checks of the system. Inspect the photocell lens for obstructions. Check all connections from the headlight switch, as well as all fuses used in the system.

**The following are some of the most common complaints that result from problems in the automatic headlight:**

1. Lights turning on and off at wrong ambient light levels.
2. Lights that do not turn on in darkness.
3. Lights not turning off in bright light.
4. Lights not staying on for an adjustable time after the ignition switch is turned off.
5. Lights that do not turn off after the ignition switch is turned off.

These problems can be caused by faults in the headlight switch, ignition switch, amplifier, or photocell. To locate the problem, perform the following test series. As a service sampler of automatic headlight system diagnosis, refer to the schematic (Figure 12-3). The following test connections will refer to those this system uses. Use the correct service information for the system you are diagnosing.

### Photocell Test

To test the photocell, use a scan tool or a DMM to measure the voltage of the photocell signal circuit to the BCM. With the engine running, observe the voltage readings. First, cover the photocell's lens with a piece of cardboard. The voltage should read 0 volts. Next, shine a flashlight onto the photocell's lens. The voltage should go up to 5 volts. If the voltages do not change, check the circuit, and if there are no problems, replace the photocell.





# PHOTO SEQUENCE 21

## TYPICAL PROCEDURE FOR REPLACING A PHOTOCELL ASSEMBLY

All photos in this sequence are © Delmar/Cengage Learning.



**P21-1** Tools required to replace the photocell assembly include nut driver set, thin flat blade screw driver, phillips screwdriver set, battery terminal pullers, battery pliers, box end wrenches, safety glasses, seat covers, and fender covers.



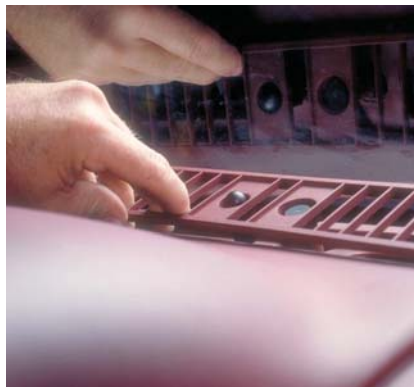
**P21-2** Place the fender covers over the vehicle's fenders and disconnect the battery negative terminal.



**P21-3** Protect the seats by placing the seat covers over them.



**P21-4** Using a clean shop rag to protect the dash pad, insert a long flat blade screwdriver into the defroster and pry it up and out.



**P21-5** Carefully pry out the vent outlets from the panel. Carefully work your way down the length of the grill, pulling it free from its seat.



**P21-6** Gently work the grill up and out to gain access to the photocell socket.



**P21-7** Twist the socket to free it from the grill.



**P21-8** Gently work the photocell free from its socket.



**P21-9** Replace the photocell and reinstall its socket into the grill.





**P21-10** Position the back side of the grill into place.



**P21-11** Work the leading edge of the grill back into place using your thumb.

6. Turn the control switch to the OFF position.
7. The ohmmeter should read infinite when connected between the L terminal and ground. If there is low resistance, check the circuit for a short. If the ohmmeter indicated infinite resistance, continue testing.
8. Connect the ohmmeter between terminals H and D. There should be 0 ohms of resistance. If not, check the two circuits for an open. If the ohmmeter indicated 0 ohms of resistance, continue testing.
9. Place the control switch in the middle of MIN and MAX settings.
10. Connect the ohmmeter between terminals A and E. There should be between 500 and 250,000 ohms of resistance. If the resistance value is not within this range, check the circuits between the amplifier and the control switch for opens.
  - If the circuits are good, observe the ohmmeter as the control switch is moved from the MIN position to the MAX position. The resistance value should change smoothly and consistently from one position to the next. If the ohmmeter indicates a resistance value out of limits or an erratic reading, replace the control switch.
11. If all of the resistance values tested are correct, continue testing.
12. Turn off all switches and reconnect the amplifier wire connector. Reconnect the battery negative terminal.
13. Turn the ignition switch to the RUN position. Turn the headlight switch to the OFF position, and turn the control switch to ON.
14. Connect a fused jumper wire between amplifier terminals J and M. The headlights should go off within 60 seconds. If the headlights go off within 60 seconds, but they do not go off normally in bright light, check the circuit for opens. If the circuit is good, replace the photocell.
15. Turn off all switches.
16. Disconnect the wire connector to the amplifier.
17. Turn the ignition switch to RUN and turn the headlight switch to OFF.
18. Connect a test light between terminal M and ground. The test light should light. If not, there is a short or open in the circuit between the battery and the amplifier or in the circuit between the amplifier and the photocell. If the test light illuminates, continue testing.

Use a 20-ampere fuse in the jumper.

19. Connect the test light between terminals M and B. The test light should light. If not, check the ground circuit for an open. If the test light illuminates, continue testing.
20. Connect the test light between terminal K and ground. The test light should light. If not, check the fuse and the circuit for an open. If the test light illuminates, continue testing.
21. Connect the test light between terminal C and ground. The test light should light. If not, check the circuit for an open. If this circuit is good, check the ignition switch. If the test light illuminates, continue testing.
22. Turn the ignition switch to OFF.
23. With the test light connected as in step 21, the test light should turn off. If not, replace the ignition switch. If the test light turns off, continue testing.
24. Connect the test light between terminal H and ground. If the test light is illuminated, replace the light switch. If the test light is off, continue testing.
25. Connect the test light between terminal F and ground. If the test light is illuminated, replace the light switch. If the test light remains off, continue testing.
26. With the test light connected as in step 25, place the headlight switch in the HEAD position. If the test light does not turn on, check the circuit and the headlight switch for opens. If the test light lights, and all other tests have the correct results, replace the amplifier.



### CAUTION:

Skipping any of the tests will result in replacement of the amplifier, even if it is good.



### SPECIAL TOOLS

Photocell resistance assembly

### Classroom Manual

Chapter 12, page 315



### SPECIAL TOOLS

Scan tool  
Calibration target  
Grease pencil  
Tape measure

## Resistance Assembly Test

The resistance assembly test is performed when the lights turn on and off at the wrong ambient light levels. Use the illustration (Figure 12-4) to construct a **photocell resistance assembly**, which replaces the photocell to produce predictable results.

Replace the photocell with the resistance assembly. Turn the resistance assembly switch to the OFF (open) position and place the ignition switch in the RUN position. If the lights do not come on within 60 seconds, replace the amplifier.

If the lights turn on, wait 30 seconds and turn the resistance assembly switch on. If the lights turn off within 60 seconds, replace the photocell. If the lights do not turn off within 60 seconds, replace the amplifier.

## SmartBeam Diagnostics

SmartBeam is one of the systems that a manufacturer may use to control automatic high-beam operation. This system is presented as an example of the diagnostic procedures used to determine and repair faults.

Customer concerns that can be related to the operation of SmartBeam will usually be in one of two categories: either the system is totally inoperative or it is not performing properly.

When diagnosing a complaint of SmartBeam inoperative, it is important that the following is done:

- Verify that the headlights work properly on both high and low beam when operated manually.
- Verify the power and ground circuits of the AHBM.

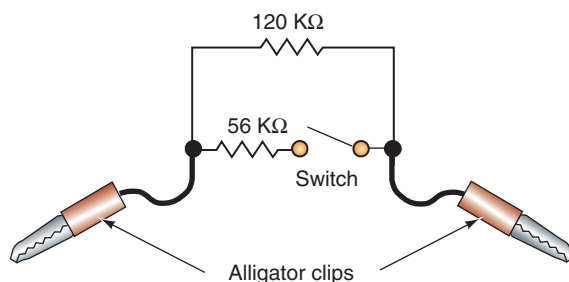
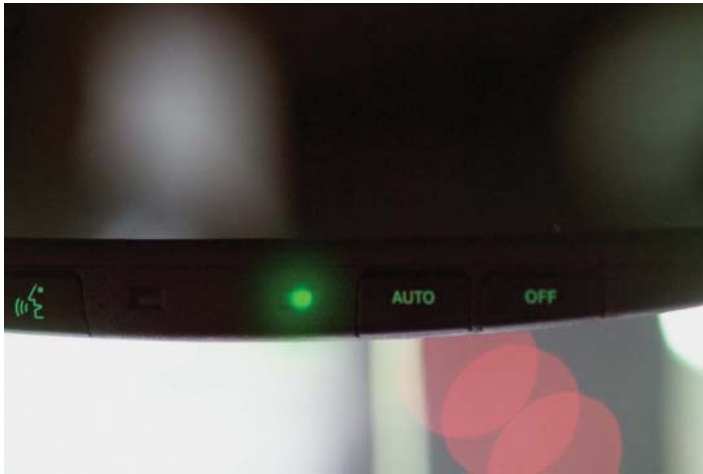


FIGURE 12-4 Photocell resistance assembly.

© Delmar/Cengage Learning



© Delmar/Cengage Learning

**FIGURE 12-5** The LED can be used to indicate auto high-beam faults.

- Verify that the system status indicator LED in the mirror (Figure 12-5) is on steady. If the LED is flashing, then a fault has been detected.
- Verify the automatic high-beam/low-beam function has been enabled (Figure 12-6).
- Verify that the headlight switch is set to the AUTO position.
- Verify that the headlight beam select switch is in the low-beam position.

Complaints related to poor system performance are usually associated with sensitivity of the system. If the system is oversensitive, the customer may complain that the high beams come on too late and go off too early. If the system is undersensitive, then the high beams will come on too early and go off too late. These types of sensitivity problems can be caused by:

- Camera not properly aimed.
- Loose camera mounting or improperly positioned mirror button.
- Obstruction in front of the camera.
- Improper headlight aiming.
- Vehicle overloading resulting in the rear of the vehicle sitting lower than the front.



© Delmar/Cengage Learning

**FIGURE 12-6** For the auto high-beam function to operate, it must be activated.



**SERVICE TIP:**

Because the SmartBeam requires the function of several vehicle modules, diagnosis of the system may require verifying the correct operation of modules other than the automatic high-beam module (AHBM) itself.



**SERVICE TIP:**

Remember that the SmartBeam system controls the high-beam portion of the headlamp system. The SmartBeam system varies the high-beam head lamp illumination intensity from low-beam level headlamp illumination intensity to full high-beam headlamp illumination intensity, and any level of headlamp illumination intensity in between.

Whenever possible, system operation can be verified on stationary vehicles by using the scan tool to manually activate the system.

**CUSTOMER CARE:** Inform the customer that the camera must have an unobstructed view from the front of the windshield for the system to perform properly. Hanging items from the mirror, or placing toll road transponders in front of the camera will result in poor performance of the system.

The SmartBeam automatic high-beam system has a **demonstration mode** that may be used to assist in diagnostics. The demonstration mode allows the function of the automatic high beams and high-beam indicator to be demonstrated while the vehicle is stationary and under any ambient lighting conditions. To initiate the demonstration mode function:

1. Begin with the ignition switch in the OFF position.
2. Depress and hold the AUTO button on the inside mirror (refer to Figure 12-5).
3. While continuing to depress the AUTO button, turn the ignition switch to the RUN position.
4. Continue to hold the AUTO button depressed until the demonstration mode begins as indicated by the high beams ramping up in intensity.
5. Release the button.

The system will complete three cycles of ramping up the headlamp high beams to full intensity and then ramping them down. During this time, the high-beam indicator should also come on and go off with the high beams. The high beams will cycle three times; then the system will return to normal operation.

The LED in the rearview mirror is also used to assist in diagnostics. Usually this LED is on steady to indicate that the auto dimming function of the electrochromic mirror is on. A flashing LED indicates the system has detected a problem. The LED can flash at different frequencies and at different sequences to indicate a problem. For example, if the LED is continuously flashing at a rate of 1 flash per second this indicates that the mirror is in need of being calibrated. To correct this condition, the camera calibration procedure must be performed.

If the LED is continuously flashing at a rate of 2 flashes per second, this indicates that the system failed its last attempt to calibrate. To correct this condition, the camera calibration procedure must be performed.

The last possible LED indication is a series of flashes when the ignition switch is first placed in the RUN position, followed by the LED staying on steady. The flashing LED can indicate a hardware failure that may require the AHBM replacement.

**Camera Calibration Test and Adjustment.** It is critical that the camera's field of view is maintained to specifications. If the camera's field of view is no longer within specifications, the performance of the system is seriously degraded. For proper operation, the camera's field of view must be maintained within 2° of the vehicle centerline and within 10° of horizontal. If the camera is aligned within these specifications, the AHBM can adjust and fine-tune the alignment based on sensed lighting inputs while driving.

The camera calibration procedure must be performed any time the inside rearview mirror is replaced with a new unit, the rearview mirror mounting button has been replaced, or the windshield has been replaced. The calibration procedure ensures that the field of vision for the camera is aimed at the proper path ahead of the vehicle. If a new camera is installed, it is shipped with the calibration mode initiated. Once the camera is installed and connected, the LED will flash continuously at a rate of once per second while the ignition switch is

in the RUN position. Before attempting to calibrate the camera, the following should be performed:

- Clean the windshield glass in front of the camera lens.
- Check for proper mounting of the mirror assembly and that the set screw that secures the assembly to the button is properly torqued at 15 in. lbs. (1.7 Nm).
- Repair or replace any faulty, worn, or damaged suspension components.
- Verify proper tire inflation pressures.
- Verify that there is no load in the vehicle, except for the driver.
- The fuel tank should be full. Add 6.5 pounds (2.94 kilograms) of weight over the fuel tank for each gallon of missing fuel.

To calibrate the camera, the centerline of the vehicle must be established and marked. A special alignment target is also required. The target consists of a black, square field containing three red LEDs positioned in a diagonal pattern (Figure 12-7). The target is placed a specified distance in front of the vehicle. Once the proper height of the target is established to match the height of the camera lens, then the target must be positioned within  $\frac{1}{2}^\circ$  of centerline of the vehicle. When in calibration mode, the AHBM is programmed to look for the red LED light pattern of the target from the camera. When the target is properly placed, the AHBM will identify it and the center of the target will become the new center of the field of view. The flashing green LED changes to a steady ON state when calibration is successful. Photo Sequence 22 illustrates the typical procedure for setting up and calibrating the camera.

If the camera cannot locate the target's pattern, the calibration fails. The LED will blink at a 2-Hz rate, indicating that the calibration procedure has failed and that a fault has been set. This may be caused by the target being incorrectly placed or the camera being improperly aligned.

If the camera fails to calibrate, a DTC will be set indicating that the performance is off in any of the four directions. To correct this condition, you will have to verify that the mounting of the camera and the position of the target were correct. If they were correct, then adjustment of camera will be necessary.

Each DTC for alignment has the description of the direction the camera should be moved to make a correction. For example, if the DTC is "High-Beam Camera Alignment Performance Bottom," the camera is locating the target but it is at the bottom of the field of view. To correct this, the camera needs to be tilted downward.



© Delmar/Cengage Learning

**FIGURE 12-7** Calibration target.



# PHOTO SEQUENCE 22

## AUTOMATIC HIGH-BEAM CAMERA CALIBRATION

All photos in this sequence are © Delmar/Cengage Learning.



**P22-1** Locate the “ASI” mark on the windshield.



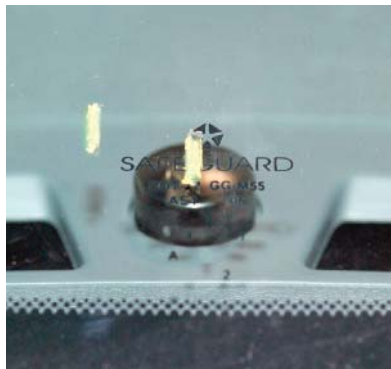
**P22-2** Using the “ASI” marks on both sides of the windshield, measure across windshield using the shaft of the tint band arrow as the reference points.



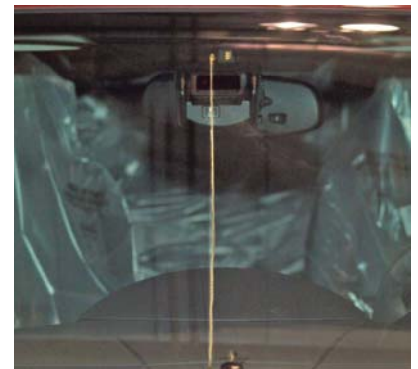
**P22-3** Divide the measurement in half and mark that dimension near the lower edge of the tint band using a grease pencil.



**P22-4** Measure across the upper edge of the blackout area at the bottom of the windshield using the inside corner of the intersection between the side blackout area and the lower blackout area as the reference points.



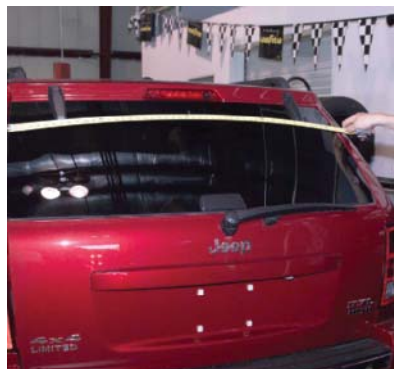
**P22-5** Divide the lower measurement in half and mark that dimension near the upper edge of the blackout area using a grease pencil.



**P22-6** To locate the centerline of the camera lens, measure and mark the glass 7/8 inch (21 mm) toward the passenger side of the windshield from the upper and lower glass centerline marks and draw a vertical line connecting these two marks.



**P22-7** Remove the grease pencil mark in front of the lens.



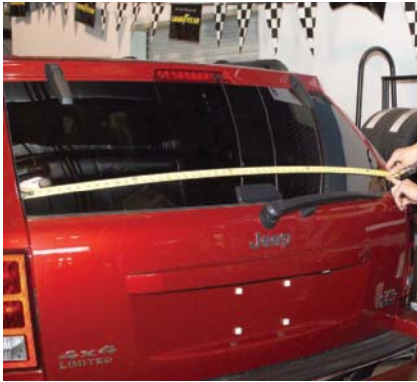
**P22-8** To locate the camera centerline on the rear glass, measure across the upper portion of the rear glass using the vertical edges of the body opening as the reference points.



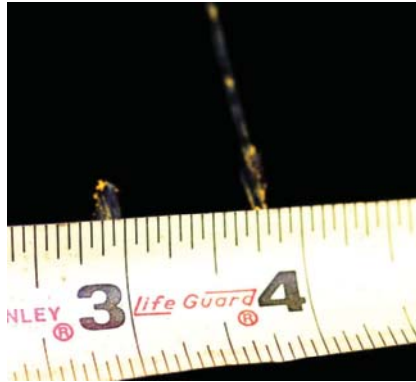
**P22-9** Divide the upper measurement in half and mark that dimension on the glass using a grease pencil.



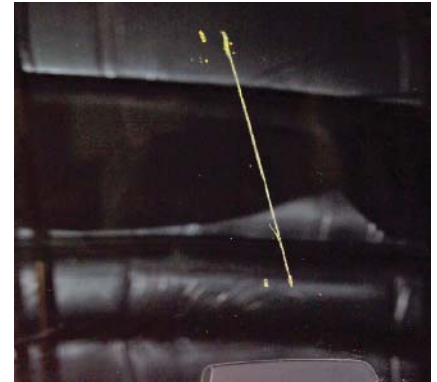
## PHOTO SEQUENCE 22 (CONTINUED)



**P22-10** Measure across the rear glass at the bottom using the vertical edges of the body opening as the reference points.



**P22-11** Divide the lower measurement in half and mark that dimension on the glass using a grease pencil.



**P22-12** Measure and mark 7/8 inch (21 mm) toward the passenger side of the rear glass on both the upper and lower references and draw a vertical line connecting these two marks.



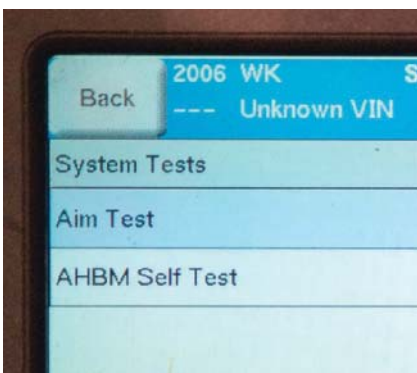
**P22-13** Locate the calibration target 50 inches (127 cm) in front of the vehicle measuring from the foremost center of the front fascia.



**P22-14** While sighting through the V-notch in the upper edge of the calibration target, move the target left or right to align the target to the camera centerline marks on both the windshield and the rear glass.



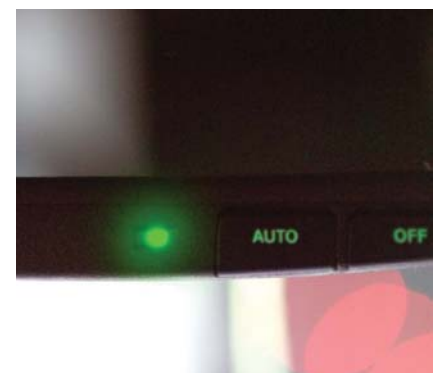
**P22-15** Adjust the tripod so that the center LED on the target 57 inches (145 cm) from the floor.



**P22-16** Use the scan tool to enter the SmartBeam unit into calibration mode. When the calibration mode is entered, the LED in the mirror assembly will flash at a rate of once per second.



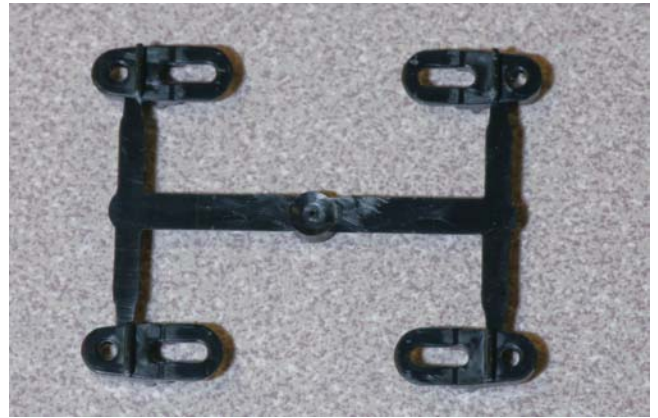
**P22-17** Turn on the LEDs in the calibration target.



**P22-18** The LED in the mirror assembly should continue to flash for five to ten seconds, then will stop flashing to indicate that it has completed calibration.



**FIGURE 12-8** An adjustment shim is used to align the camera.



**FIGURE 12-9** The adjustment shim.

Camera alignment is done by the placement of a spacer between the camera mount and the camera housing (Figure 12-8). The adjustment spacer consists of four stepped shims connected by an integral plastic tree (Figure 12-9).

Determine what shim movement will be required to correct the alignment based on the DTCs retrieved (Figure 12-10). To adjust the camera alignment, move the inside rearview mirror head downward so access to the two screws securing the rear cover can be obtained. Remove the two screws, and then adjust the mirror head up toward the headliner to its uppermost position. Unsnap and pull the upper edge of the rear cover away from the housing far enough to disengage the tabs at the lower edge of the cover; then remove the rear cover.

With the mounting bracket now accessible, carefully cut the plastic tree for the shims at the appropriate location(s) to allow movement of the shims determined earlier. With the shims separated from the tree, loosen the attaching screws one-half turn. The screw holes in the shims are slotted to allow sliding of the shims. Slide the shim beneath each of the loosened screws to its most outboard position. Once the shims are relocated into the desired position, the attaching screws are then tightened to 7 in. lbs. (0.8 Nm). As the screws are tightened, the camera is pulled into the new alignment position. The total amount of correction is 2 to 2.5°. Only two shims can be moved for correction. The shims moved must be either:

- Both top shims, to tilt the camera upward.
- Both bottom shims, to tilt the camera downward.
- Both left shims, to tilt the camera to the left.
- Both right shims, to tilt the camera to the right.

Reinstall the mirror assembly rear cover. Use the scan tool to erase any DTCs, and perform the calibration procedure again. If the correct shims were moved and the necessary correction was within the range of adjustment, calibration should be successful.

**Camera Optics Test.** If the automatic high-beam system is performing poorly, but the LED does not flash, the camera's optics may be dirty or obstructed. The camera's optics can be tested by entering the demonstration mode. The **optics test** will confirm that the camera can recognize ambient light through the lens and the windshield. To perform the optics test, first initiate the automatic high-beam demonstration mode. While observing the LED, obstruct the view of the imager by placing a piece of cardboard between the camera lens and the windshield. The LED should turn off each time the optics are obstructed by the cardboard. Once the cardboard is removed, the LED should illuminate again.

Failure of the LED to respond to these inputs indicates that the imager optics is obstructed. Clean the lens and the windshield glass and/or remove any obstructions from the windshield in front of the imager. To clean the imager lens, spray a small amount of glass cleaner onto a



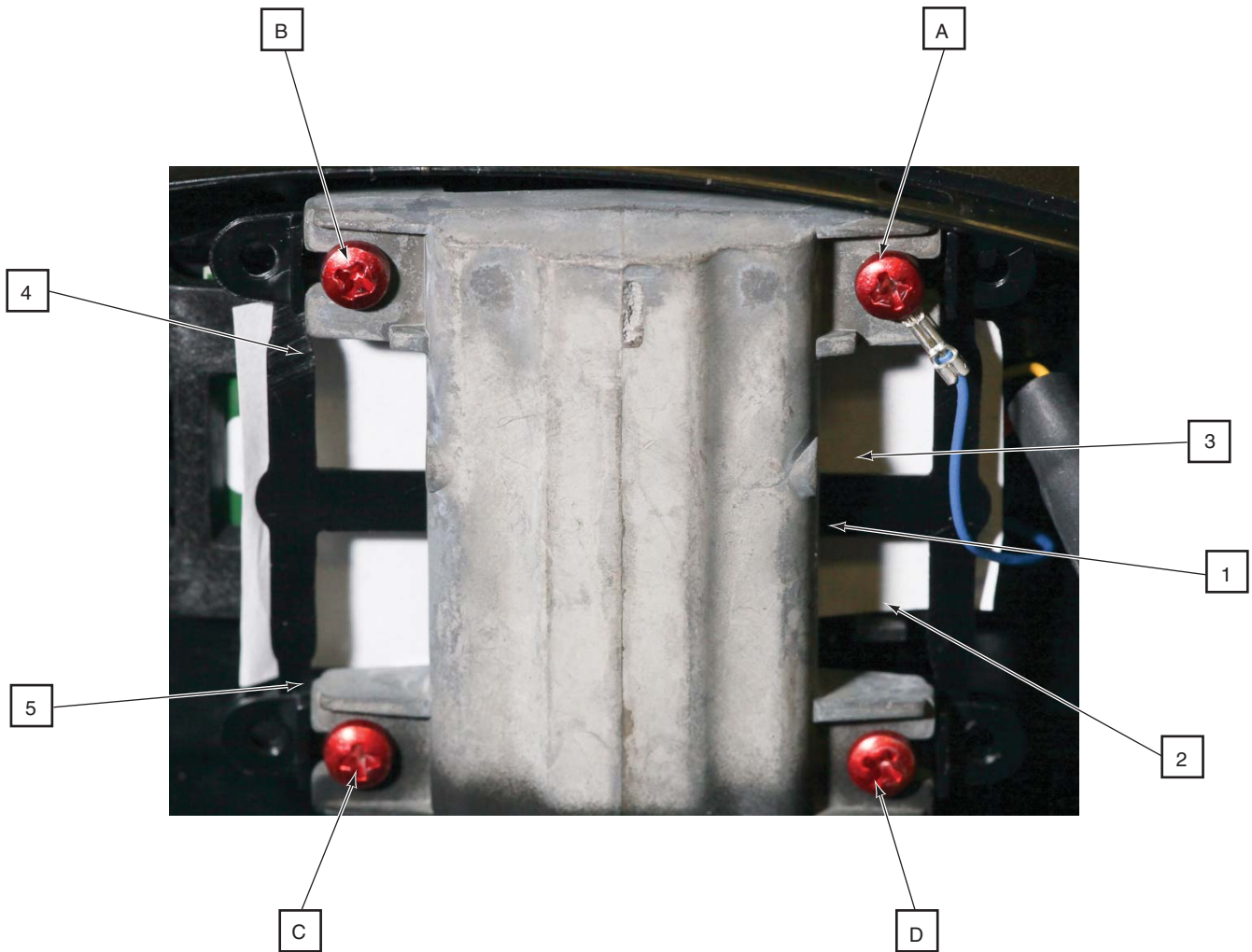
### SERVICE TIP:

If more than one high-beam camera alignment performance fault DTC was retrieved, then one screw and one shim will be common to both of the faults. Make the correction at this location.



### CAUTION:

Do not spray glass cleaners directly onto the imager lens. Damage to the imager optics and electronics may result.



Camera Adjustment Table		
Fault	Tree Cut Location	Shim + Screw Location
Right	1	A + D
Left	1	B + C
Top	3 + 4	A + B
Bottom	2 + 5	C + D

**FIGURE 12-10** Adjustment chart and locations.

soft cloth and gently wipe the lens clean. After cleaning the lens and the windshield, repeat the test to confirm proper automatic high-beam system operation.

## HEADLIGHT LEVELING SYSTEMS

The headlight leveling system is designed to adjust the beam projection of the headlights based on vehicle load and other considerations. Two types of systems are commonly used: driver-initiated level by use of a switch or thumb wheel, and automatic leveling.

The first requires the driver to adjust the headlights using a switch or thumb wheel to select the level. The switch is located in the instrument panel bezel. Generally there will be





## SPECIAL TOOLS

Scan tool  
DMM



### CAUTION:

To avoid serious or fatal injury, disable the Supplemental Restraint System (SRS) before attempting any component diagnosis or service. Disconnect and isolate the battery negative cable and wait at least two minutes to allow the system capacitor to discharge before performing further diagnosis or service.

four positions that will lower the headlight beam as the vehicle load increases. The switch is a MUX switch that sends a voltage signal to the controller board and logic circuitry of the headlamp leveling motor. The motor is located in the headlight housing. When the motor is energized, it will extend or retract the motor pushrod through the integral screw-drive transmission. The other end of the pushrod is snapped into a socket on the back of the reflector, which causes the reflector to move as the pushrod is extended or retracted. The reflector position changing the angle at which the light is projected from the headlamp.

The leveling motors and switch have a direct connection to chassis ground. Although there are differences between manufacturers on power supply to the switch and motors, a common method is supply power only when the headlights are turned on. This can be accomplished by supplying voltage to the switch and motors through the fused park lamp relay output circuit.

The headlamp leveling switch as well as the hard wired inputs and outputs of the switch may be diagnosed using a DMM. Use the appropriate wiring information when testing the circuits. The following is an example of testing the switch function using a DMM. The switch terminals are identified in Figure 12-11.

Using the ohmmeter function of the DMM, perform the resistance tests at the terminal pins in the switch pod connector receptacle as shown in Table 12-1. If the switch fails any of the resistance tests, replace the switch.

Because of active electronic elements located in the leveling motor, it cannot be tested using conventional diagnostic tools and procedures. If the headlamp leveling motor is believed to be defective, the hard wired headlamp leveling motor circuits and the leveling switch must be tested before considering motor replacement.

The second system automatically levels the headlamps, regardless of cargo or passenger loads or road conditions. When the vehicle is loaded with passengers and/or cargo, the

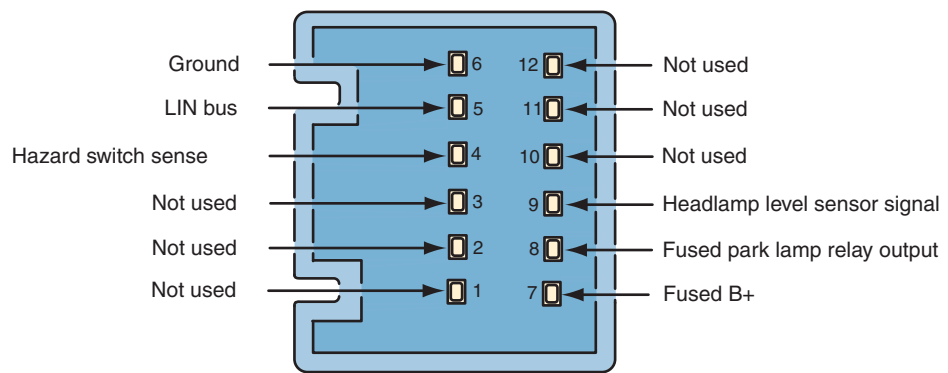
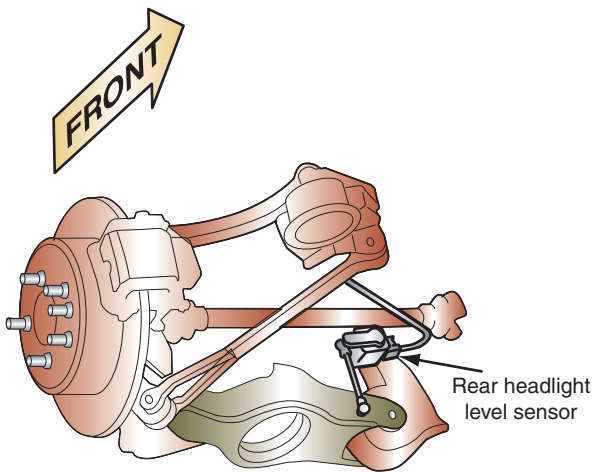


FIGURE 12-11 Leveling switch terminal callouts.

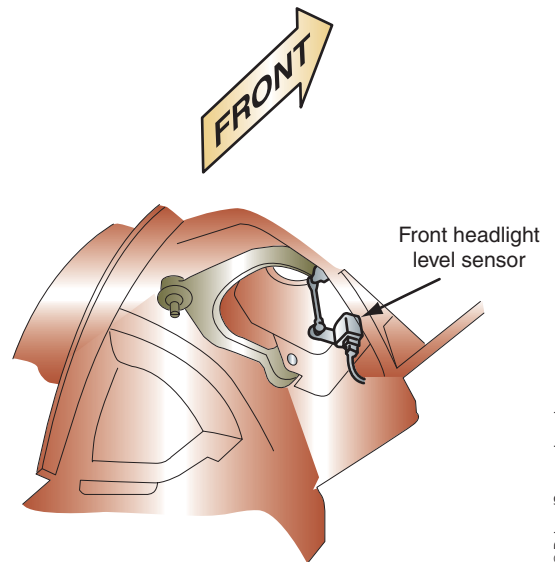
TABLE 12-1 Table of resistance test for leveling switch.

HEADLAMP LEVELING SWITCH TESTS			
SWITCH POSITION	RESISTANCE (OHMS) $\pm$ 1% BETWEEN PINS 6 AND 9	RESISTANCE (OHMS) $\pm$ 1% BETWEEN PINS 6 AND 8	
0	1518	1750	
1	1971	2203	
2	3661	3893	
3	9851	10183	



**FIGURE 12-12** Rear sensor for automatic headlight leveling system.

© Delmar/Cengage Learning



**FIGURE 12-13** Front sensor for automatic headlight leveling system.

© Delmar/Cengage Learning

system will use input from the front and rear sensors and make an adjustment based upon feedback from the sensor to see if it has approximately 27.5 degrees from its zero or neutral position. The sensors determine if the vehicle has had its ride height or angle changed, due to passenger or cargo additions and road conditions.

There is one sensor mounted on the spring link on the right side of the rear suspension (Figure 12-12). The other sensor is mounted on the upper control arm on the right side, in the front of the vehicle (Figure 12-13).

This system will use a headlamp stepper motor that adjusts the headlamp reflector up or down for proper headlamp aiming. The headlamp level will be adjusted while driving if required based on sensor inputs. A headlight leveling module uses the input from the sensors to control the operation of the stepper motor. The module is also capable of monitoring the system for faults. If a system fault occurs, the module will store the DTC and enable it to be read using the scan tool to assist in diagnosing the headlamp leveling system.

Usually there is not an adjustment to the sensor linkage. However, anytime the sensors are removed or replaced, the system needs to be calibrated using a scan tool. This is also true if the headlamp leveling module is replaced.

When performing the calibration function, the vehicle must be level. Place the ignition in the RUN position and confirm that the vehicle doors, trunk or liftgate, and hood are all closed. Make sure no one is seated in vehicle and that the vehicle is not disrupted (bounced or bumped) until the calibration procedure is complete. Also, the headlamps must be ON to power the stepper motors. Calibration will take approximately 12 to 15 seconds to complete. The scan tool will display a “status of calibration” message. The message will be either “still in progress,” “passed,” or “failed.”

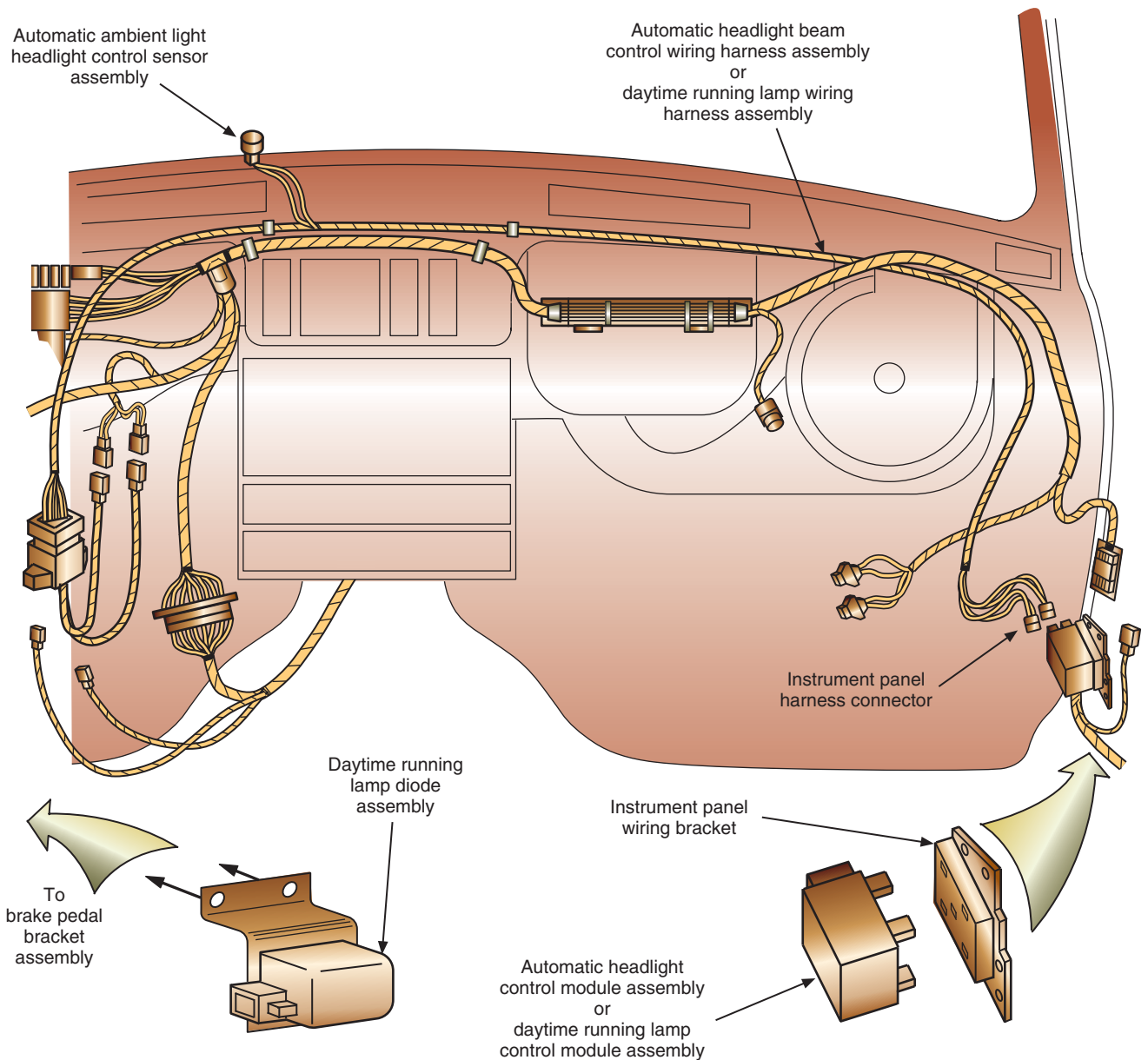
If the calibration failed, use the wiring diagram to confirm all circuits are functioning properly. If there is no problem with the circuits, the module is probably the fault. Confirm power and grounds to the module before replacing it.

The headlight aiming module is also referred to as the HID translator module.

## Daytime Running Lamps

All late-model Canadian vehicles and many newer domestic vehicles are equipped with daytime running lamps. The daytime running lamp (DRL) system includes a solid-state control module assembly, a relay, and an ambient light sensor assembly (Figure 12-14). The system lights the low-beam headlights at a reduced intensity when the ignition switch is in the RUN

**Classroom Manual**  
Chapter 12, page 320



**FIGURE 12-14** Automatic headlamp control module, daytime running lamp control module, and lamp diode assemblies.

position during daylight. The daytime running lamp system is designed to light the low-beam headlamps at full intensity when low-light conditions exist.

As the intensity of the light reaching the ambient light sensor increases, the electrical resistance of the sensor assembly decreases. When the DRL control module assembly senses the low resistance, the module allows voltage to be applied to the DRL diode assembly and then to the appropriate headlamps. Because of the voltage drop across the diode assembly, the headlamps are on with a low intensity.

As the intensity of the light reaching the ambient light sensor decreases, the electrical resistance of the sensor increases. When the DRL module assembly senses high resistance in the sensor, the module closes an internal relay, which allows the headlamps to illuminate with full intensity.

Some manufacturers use a DRL module that receives inputs from either the headlight switch or the BCM to determine switch position. If the switch is in the OFF or AUTO position



(and ambient light is high enough that the headlights do not need to be on), the DRL module will send a PWM signal to the headlight beam. This turns the headlight on, but at reduced illumination levels.

Some vehicles will use the parking lamps for the DRL function. In this case, the headlight position is used to determine if the headlights are on. If they are not, the BCM or DRL module will turn on the park lamp relay.

Diagnostics of either type of system is performed by using a scan tool or DMM. As with any system, determine proper power and ground circuit operation. Also, remember that the parking brake switch is used as an input. If the switch should fail and indicates to the DRL module that the parking brakes are applied, the DRL function is disabled.

## ILLUMINATED ENTRY SYSTEM DIAGNOSIS

The diagnostic procedures for testing the illuminated entry system depend upon the manufacturer. Always refer to the service information for the vehicle you are working on. Always perform a visual inspection before performing any tests. First check the fuse. Then check to make sure all connections are tight and clean. Inspect the ground wires for good connections. Check all visible wires for fraying or damaged insulation, especially where they go through body parts. Make sure all doors are closed properly and the headlight switch is in the detent position.

The following are typical procedures for diagnosing the illuminated entry system.

Systems that are activated by lifting the outside door handle use a contact switch that momentarily closes to complete the ground circuit of the **illuminated entry actuator** module. The module activates the interior lights for 25 seconds or until the ignition switch is placed in the RUN or ACC position.

A logic circuit is included in the module to prevent battery drain if the door handle is held up for longer than 25 seconds. The system will operate as normal until the 25 seconds have elapsed, and then the module will turn off the lights. The lights will remain off and cannot be reactivated until the handle is returned to the released position.

This type of system has four main components (Figure 12-15). The door lock cylinder uses an LED to provide the illumination of the cylinder. The lens of the LED is built into the cylinder.

To test the system, disconnect the actuator harness from the actuator. Refer to Figure 12-20 and connect the test light between terminal 8 and ground. The test light should illuminate with the ignition switch in the OFF or RUN position. If the test light fails to come on, trace the circuit back to the fuse box to locate the problem.

Connect the test light between terminal 7 and ground. The test light should not glow with the ignition switch in the OFF position. When the ignition switch is turned to the RUN or ACC position, the test light should come on. If the test light does not turn on and off as the ignition switch is turned, trace the circuit to the fuse box and the ignition switch to locate the problem.

Connect a jumper wire between connector terminals 6 and 8. Make sure all doors are closed. The courtesy lights and door lock cylinders should be illuminated. If the lights did not operate, trace the circuit from terminal 26 to the LEDs and ground to locate the problem.

Connect an ohmmeter between connector terminal 2 and chassis ground. The ohmmeter should indicate an infinite reading. However, a minimum of 10,000 ohms is acceptable. Lift up on each of the outside door handles to close the latch switch. Hold the handle up while observing the ohmmeter. The ohmmeter should indicate a resistance value of 50 ohms maximum. If either of the ohmmeter readings are out of specifications, trace the circuit to the latch switches. Also, test the latch switches for correct operation.

With the test light connected between connector terminals 1 and 8, the light should be on. If the test light fails to come on, trace the circuit from terminal 1 to ground.

### Classroom Manual

Chapter 12, page 323



### SPECIAL TOOLS

Test light  
DMM  
Jumper wire  
Service information



### CAUTION:

The normal operating voltage for the LED is 3 volts. The circuit uses a dropping resistor to protect the LED. Do not apply 12 volts to the LED circuit ahead of the resistor. If the resistor is bypassed, the LED will be destroyed. When applying voltage to test the LED, apply it only to the connector terminals.

On some systems, terminal 4 is used. On these systems, jumping between terminals 6 and 8 will illuminate the courtesy lights. Jumping between terminals 4 and 8 will light the door lock cylinders only. If they do not, trace circuit 464.

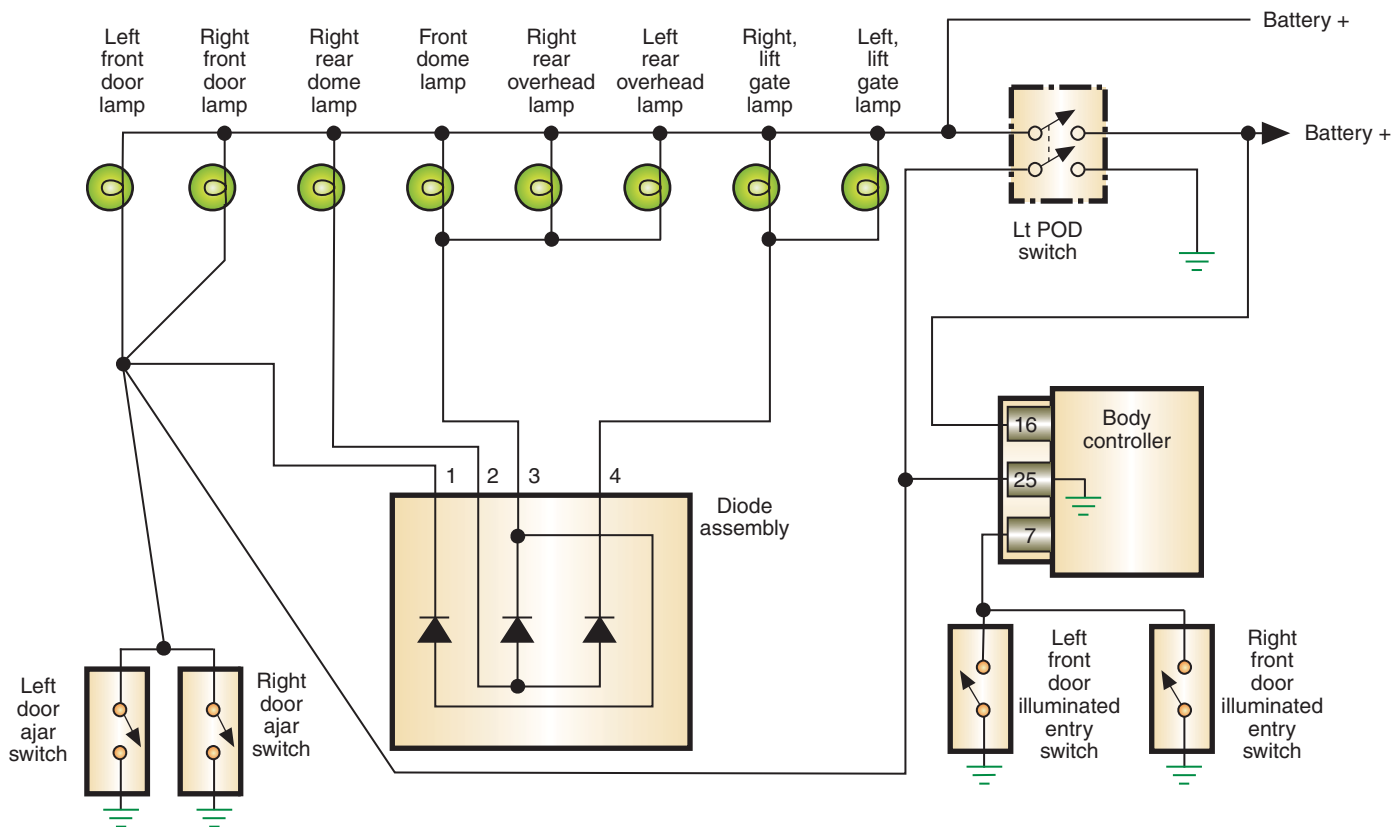


FIGURE 12-15 Schematic of an illuminated entry system.

If the preceding tests did not indicate any problems, the actuator module assembly is faulty. The module must be replaced.

Follow these steps to diagnose the system illustrated in Figure 12-15:

1. Move the dimmer control to the center position.
2. Open the driver's-side door to activate the courtesy lights. If none of the courtesy lights turn on, continue testing. If only one bulb is inoperative, check its circuit and the bulb.
3. Lower the driver-side window and close all doors. Manually lock the driver's door. Wait 30 seconds with the ignition switch off.
4. Activate the illuminated system by lifting the driver's door handle. If the lights come on, repeat the test for the right side door. If the system does not operate when the right side door handle switch is closed, refer to the service information for the circuits to be tested. The procedure will be the same as when the left door is inoperative. However, the circuit designations are different.
5. If the lights do not turn on when the door handles are lifted, connect the scan tool to the diagnostic connector. Maneuver through the menu screens to locate the door handle switch state.
6. With the ignition switch on, observe the scan tool display while lifting the door handle. The display should indicate the switch closed when the handle was lifted. If the switch operated correctly, go to step 7. If the display did not indicate proper switch operation, connect a jumper wire from the controller terminal identified in the service information to ground. This would be terminal 7 at the BCM in Figure 12-15. Observe the scan tool. If it indicates the circuit is closed, follow the service information procedure for testing the door switches. If the display indicates the circuit is open, replace the BCM.
7. Open the driver's-side door. If the courtesy lights do not turn on, go to step 8. Close all doors and jumper the terminal of the BCM identified in the service information (terminal 25 in



### SPECIAL TOOLS

Scan tool  
Service information  
Fused jumper wire  
DMM  
Test light



### CAUTION:

The terminal to jump from the controller is different between years and models. Be sure to refer to the service information for the correct terminals.

Figure 12-15) to ground. If the lights do not turn on, there is an open circuit between the BCM and the lamps. If the lights turned on when the BCM was jumped, replace the BCM.

8. If the lights did not come on in step 7 when the door was opened, gain access to the driver's side door ajar switch harness and disconnect it. Use a jumper wire to jump across the two terminals of the connector on the harness side. This should complete the circuit to ground and the lights come on. If the lights do not turn on, check both circuits for an open. If the lights come on when the connector is jumped, replace the switch. Test the door ajar switch for the passenger side in the same manner. Use a jumper wire to jump across the two switch connector terminals on the harness.

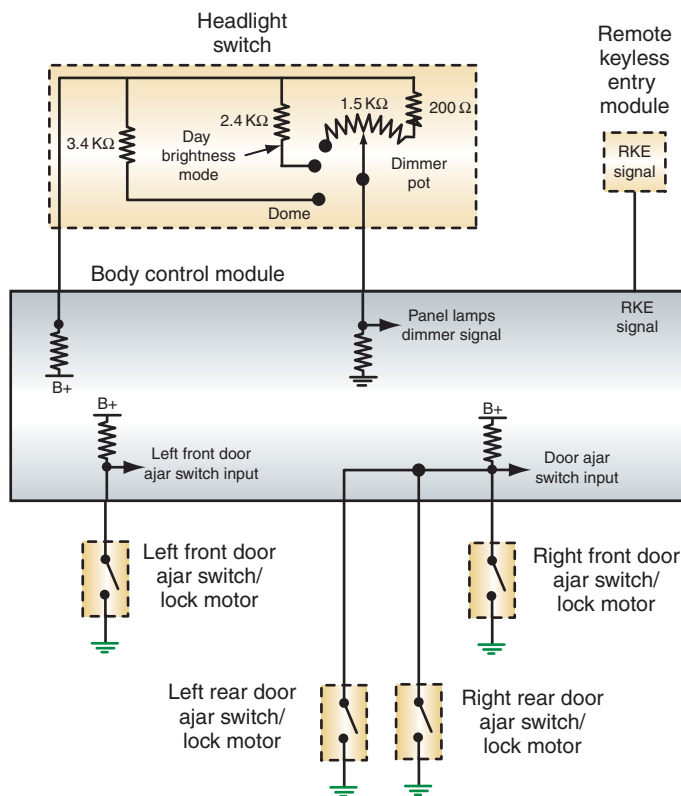
Some BCM-controlled illuminated entry systems do not use a door handle switch. The system is activated when the doors are opened or the remote keyless entry system is used to unlock the doors. The system uses the same lamp driver as the courtesy lamps. Check for operation of the system by opening each door, one at a time. Usually the three passenger door ajar switches are connected in parallel with the driver's door on its own circuit (Figure 12-16). If the system does not activate when the doors are opened, use the remote keyless entry fob and press the UNLOCK button. If the system works now, the problem is in the door ajar input circuits or the BCM. If using the fob does not activate the system, the fault is probably in the BCM or the control circuits to the lamps. However, it is possible that all inputs are missing. To confirm this, use the scan tool to activate the system. If the lamps illuminate now, each input will need to be tested.

To test the inputs to the BCM, use a scan tool to monitor the door ajar switches. The switches should change state as the doors are opened and closed. The scan tool will display the state of the switches, not the door. The switches are open when the door is closed, and the switches are closed when the door is open. If no change of state is seen, test the door



**SERVICE TIP:**

You can also use the headlight switch dimmer function to test the lamps. Turn the switch to the DOME position. If the light come on now, the output circuit from the BCM is working fine and the problem is in the inputs.

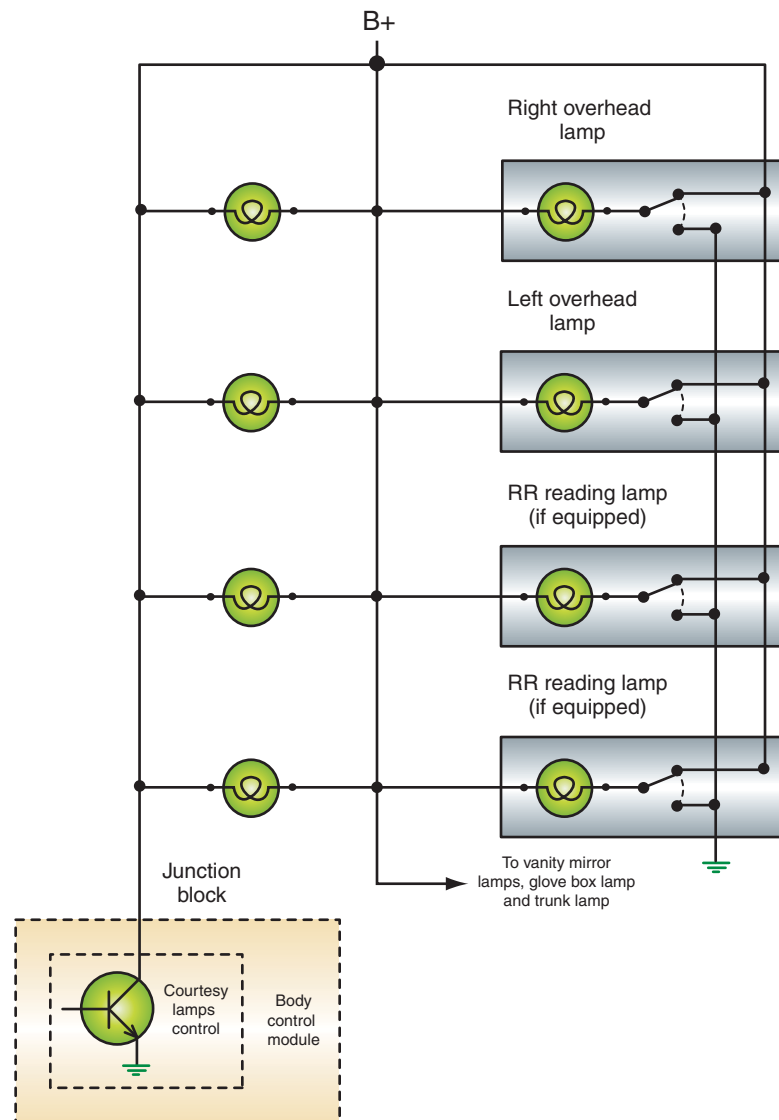


**FIGURE 12-16** The inputs used for the illuminated entry system. Note the passenger door ajar switches are in parallel.

© Delmar/Cengage Learning

ajar signal circuit by disconnecting the door ajar switch. Connect a jumper wire across the connector on the BCM side. If the illuminated entry system activates now (or the scan tool displays the switch as closed), there is a faulty switch. If this still does not activate the system, test for battery voltage to the switch connector. If battery voltage is not present, test the circuit back to the BCM by back probing for voltage at the BCM connector. If voltage is present now, there is an open in the wire between the BCM and the switch. If voltage is not present, check for good battery feed to the BCM and proper ground connections. If these are good, replace the BCM. If battery voltage is present at the switch connector when tested above, the fault is in the ground circuit for the switch.

If the scan tool indicates proper input from the door ajar switches and the activation test failed to illuminate the lamps, then the output side of the system must be tested (Figure 12-17). Locate the proper wire into the BCM connector for the courtesy lamp control. Using a back-probing tool, jump this terminal to a good ground. If the lamp turns on now, check for proper battery feed and grounds to the BCM. If these are good, replace the BCM. If the lamps do not turn on, use the manual switches to turn on each light. If they do not turn on, trace the circuit from the battery to the common connection or splice.



© Delmar/Cengage Learning

**FIGURE 12-17** Output control of the illuminated entry system.

## FIBER OPTICS DIAGNOSIS

The fiber optic system uses plastic strands to transmit light from the source to the object to be illuminated. The strands of plastic are sheathed by a polymer that insulates the light rays as they travel within the strands. The light rays travel through the strands by means of internal reflections. Fiber optics can be used to provide light in areas where bulbs would be inaccessible for service.

If the fiber optics do not illuminate, most likely the light source has failed. Check to see that the bulb is illuminating. If the bulb turns on, check that the fiber optic lead is connected to the light source and to the lens. If these are good, the only other cause is that the cable is cut. It will need to be replaced.

### CASE STUDY

A customer brings a vehicle into the shop because of an intermittent problem with the headlight delay feature. This person has taken the vehicle to other shops and spent several dollars in repair bills, but the problem has not been corrected. Using a systematic diagnostic approach and following the tests outlined in the service information leads the technician to test the potentiometer in the control switch. The resistance value is within specifications. However,

while moving the potentiometer from the MIN to the MAX position, the ohmmeter reading is erratic in one portion. This area is the usual setting selected by the driver. The technician calls the customer and receives approval to replace the control switch. The new switch cures the problem. The technician opens the old switch and finds that carbon from electrical arcing has built up in the problem area of the potentiometer.

### TERMS TO KNOW

Demonstration mode  
Illuminated entry  
actuator  
Optics test  
Photocell resistance  
assembly

## ASE-STYLE REVIEW QUESTIONS

1. The results of a functional test on the automatic headlight system are being discussed.

*Technician A* says when the photocell is covered and the engine is running, the headlights should turn on within 30 seconds.

*Technician B* says when a bright light is shone onto the photocell, the lights should turn off after the selected amount of time delay.

Who is correct?

- A. A only                      C. Both A and B  
B. B only                      D. Neither A nor B

2. The results of the photocell resistance test are being discussed.

*Technician A* says if the lights do not turn on within 60 seconds when the resistance assembly switch is in the OFF (open) position and the ignition switch is in the RUN position, the photocell should be replaced.

*Technician B* says if the lights turn off within 60 seconds after the resistance assembly switch is turned on, the photocell should be replaced.

Who is correct?

- A. A only                      C. Both A and B  
B. B only                      D. Neither A nor B

3. The automatic high-beam function does not operate properly. The LED in the mirror assembly is flashing continuously at a 1-Hz frequency. This can indicate:
- The mirror assembly is in need of being calibrated.
  - The system failed its last attempt to calibrate.
  - A hardware failure has occurred.
  - None of the above.
4. An indicator that uses fiber optics is not functioning. This can be caused by:
- A bent fiber-optics cable.
  - A faulty light source.
  - Electromagnetic interference.
  - None of the above.
5. The most likely cause of the automatic headlights failing to activate in low ambient light conditions is:
- A faulty ignition switch.
  - Camera angle alignment out of specifications.
  - Burned-out headlight elements.
  - Faulty headlight switch.
6. *Technician A* says problems with the automatic headlight system can be the fault of the headlight switch. *Technician B* says a bad ignition switch may cause the lights to not come on. Who is correct?
- A only
  - B only
  - Both A and B
  - Neither A nor B
7. The fiber-optic indicator is not operating. *Technician A* says the cable can be cut. *Technician B* says the light source may not be operating. Who is correct?
- A only
  - B only
  - Both A and B
  - Neither A nor B
8. The photocell resistance assembly is being discussed. *Technician A* says it is a technician-made test tool consisting of resistors and a switch. *Technician B* says it is a known good replacement photocell. Who is correct?
- A only
  - B only
  - Both A and B
  - Neither A nor B
9. The headlights work in the manual position but do not turn on in the AUTO position. What is the most likely cause?
- A bad headlight ground.
  - A faulty photocell assembly.
  - A faulty headlight relay.
  - A bad headlight relay ground connection.
10. *Technician A* says the photocell signal voltage should be 5 volts with the lens covered. *Technician B* says the signal voltage should be 0 volts with the a flashlight shining on the lens. Who is correct?
- A only
  - B only
  - Both A and B
  - Neither A nor B



## ASE CHALLENGE QUESTIONS

---

- An inoperative BCM-controlled automatic headlamp four-door system is being discussed; the doors will open but will not close.  
*Technician A* says that the headlight door motor may be faulty.  
*Technician B* says that the headlamp switch may be faulty.  
Who is correct?

A. A only            C. Both A and B  
B. B only            D. Neither A nor B
- The high-beam headlamps of a vehicle equipped with a Twilight Sentinel automatic headlamp system are inoperative; the low beams are working correctly. A voltmeter connected across the high-beam contacts of the dimmer switch indicate 0.15 volt when the high beams are “on.”  
*Technician A* says that the circuit from the Sentinel amplifier to the dimmer switch has excessive resistance.  
*Technician B* says that the dimmer switch is faulty.  
Who is correct?

A. A only            C. Both A and B  
B. B only            D. Neither A nor B
- A DaimlerChrysler vehicle equipped with a BCM-controlled illuminated entry system is being discussed. The system is working fine except for the fact that three interior bulbs (of a total of eight) are inoperative. A voltmeter connected across the terminals of the inoperative bulbs indicates 12.6 volts when the system is in operation.  
*Technician A* says that the BCM is working correctly.  
*Technician B* says that the diode assembly may be faulty.  
Who is correct?

A. A only            C. Both A and B  
B. B only            D. Neither A nor B
- The lamp outage module is illuminating the lamp-out warning light, but the lamp operates.  
*Technician A* says installation of the wrong light bulb can cause this.  
*Technician B* says a corroded connection can cause this.  
Who is correct?

A. A only            C. Both A and B  
B. B only            D. Neither A nor B
- The headlights work normally, except they do not turn on in the automatic mode. What is the LEAST likely cause?

A. Faulty photocell.  
B. Faulty amplifier.  
C. Faulty headlight switch.  
D. Faulty headlight relay.

*This page intentionally left blank*

Name \_\_\_\_\_ Date \_\_\_\_\_

## TESTING AN AUTOMATIC HEADLIGHT SYSTEM

Upon completion of this job sheet, you should be able to diagnose an automatic headlight system and test the individual components of the system.

### ASE Correlation

This job sheet is related to the ASE Electrical/Electronic System Certification Exam's content area: *Headlights, Parking Lights, Taillights, Dash Lights, and Courtesy Lights*; task: Inspect, test, and repair or replace headlight and dimmer switches, relays, control units, sensors, sockets, connectors, and wires of headlight circuits.

### Tools and Materials

- A vehicle with an automatic headlight system
- Wiring diagram for the chosen vehicle
- Component locator for the chosen vehicle
- Service information for the chosen vehicle
- A fused jumper wire
- A DMM

### Describe the vehicle being worked on:

Year \_\_\_\_\_ Make \_\_\_\_\_ Model \_\_\_\_\_  
 VIN \_\_\_\_\_ Engine type and size \_\_\_\_\_

### Procedure

### Task Completed

1. Locate the photocell. Then disconnect the connector to the photocell.  
 Turn the ignition switch and the automatic headlamp control to ON.  
 Turn the headlight switch off.  
 If the lights come on within 60 seconds and the automatic headlights didn't work before, the photocell must be bad. If the lights still don't come on, test the amplifier unit.  
 Describe what happened.

- 
- 
- 

---

---

---

---

---

---

---

---

**Task Completed**

- 
- 
- 
- 

2. Turn the ignition off. Disconnect the negative cable from the battery. Locate the amplifier assembly and disconnect the electrical connector to it. Turn the headlight switch off. Turn the automatic headlight control to its ON position. Locate the resistance checks of the amplifier circuit in the service information. Briefly outline those procedures.

---

---

---

---

3. Follow the previously described procedures and list the results.

---

---

---

---

4. Turn the automatic headlight control to its ON position. Locate the resistance checks of the amplifier circuit in the service information. Briefly outline those procedures.

---

---

---

---

5. Follow the procedures in step 4 and list the results.

---

---

---

---

6. List any additional diagnostic steps that the manufacturer recommends in the case where the previously described tests did not identify the problem.

---

---

---

---

---

---

---

---

Instructor's Response \_\_\_\_\_

---

---

Name \_\_\_\_\_ Date \_\_\_\_\_

## TESTING THE BCM-CONTROLLED HEADLIGHT SYSTEM

Upon completion of this job sheet, you should be able to test the computer-controlled headlight system and determine needed repairs.

### ASE Correlation

This job sheet is related to the ASE Electrical/Electronic System Certification Exam's content area: *Headlights, Parking lights, Taillights, Dash Lights, and Courtesy Lights*; tasks: Inspect, test, and repair or replace headlight and dimmer switches, relays, control units, sensors, sockets, connectors, and wires of headlight circuits.

### Tools and Materials

A vehicle equipped with BCM-controlled headlights	Test light
Scan tool	Fused jumper wires
DVOM	Wiring diagram for the vehicle

### Describe the vehicle being worked on:

Year \_\_\_\_\_ Make \_\_\_\_\_ Model \_\_\_\_\_  
 VIN \_\_\_\_\_ Engine type and size \_\_\_\_\_

### Procedure

Task Completed \_\_\_\_\_

1. Test the operation of the headlights. Describe the symptoms.

\_\_\_\_\_  
 \_\_\_\_\_

2. Are there any other related symptoms?  Yes  No  
 If yes, describe the symptom(s):

\_\_\_\_\_  
 \_\_\_\_\_

3. Describe the basic operation of the system you are working on.

\_\_\_\_\_  
 \_\_\_\_\_  
 \_\_\_\_\_

4. Check any associated fuses and conduct a visual inspection of the system. List any problems found.

\_\_\_\_\_  
 \_\_\_\_\_

Repair any faults found and test system operation. Did this fix the problem?

Yes  No

---

**Task Completed**

5. If used, substitute the headlamp relay with a known good relay of the same type and test operation. Test the system operation. Did this fix the problem?  Yes  No

6. Connect the scan tool and record any DTCs.

---

---

7. Use the scan tool to perform an activation test of the headlights. Did the headlamps come on during the activation?  Yes  No

What do you know about the problem so far?

---

---

8. Use the scan tool to monitor the headlight switch as it is placed in all switch positions. Record the voltages for each position and compare to specifications.

---

---

9. What do you know about the system so far?

---

---

10. Remove the headlight relay and use a voltmeter or test light to confirm battery voltage is present at pins 30 and 86 of the junction block terminals. Is voltage present at these terminals?  Yes  No

If NO, what would you test next?

---

---

11. If voltage is present at both terminals in step 10, use a fused jumper wire to connect pin 30 to pin 87. Did the lights come on?  Yes  No

What do you know about the circuit now?

---

---

12. Connect a test light between pins 86 and 85 of the junction block terminals (relay removed). Place the headlight switch into the headlamp position and observe the test light. What does this test check?

---

---

13. Based on your results for step 12, what do you know about the problem?

---

---

14. What other checks need to be performed to pinpoint the fault?

---

---



15. Perform the tests you listed and record your findings and recommendations.

Task Completed

---

---

Instructor's Response \_\_\_\_\_

---

---

*This page intentionally left blank*

Name \_\_\_\_\_ Date \_\_\_\_\_

## DIAGNOSING AUTOMATIC HIGH-BEAM SYSTEMS

Upon completion of this job sheet, you should be able to diagnose the cause of poor automatic high-beam system operation and determine needed repairs.

### ASE Correlation

This job sheet is related to the ASE Electrical/Electronic System Certification Exam's content area: *Headlights, Parking Lights, Taillights, Dash Lights, and Courtesy Lights*; task: Diagnose, inspect, test, and repair dimmer control units and determine necessary action.

### Tools and Materials

- Vehicle with SmartBeam
- Calibration target
- Grease pencil
- Scan tool
- Tape measure
- Piece of cardboard
- Service information

### Describe the vehicle being worked on:

Year \_\_\_\_\_ Make \_\_\_\_\_ Model \_\_\_\_\_  
 VIN \_\_\_\_\_ Engine type and size \_\_\_\_\_

### Procedure

Task Completed \_\_\_\_\_

For this job sheet task, you will identify the operational characteristics of the SmartBeam automatic high-beam system and calibrate the camera.

1. Turn on the ignition. Observe the SmartBeam camera status LED and determine if the camera is calibrated. Is the SmartBeam camera calibrated?  
 Yes                       No

**Note:** If the camera is not calibrated, it must be calibrated prior to entering demonstration mode.

2. Turn off the ignition. Press and hold the AUTO button on the rearview mirror while turning the ignition switch to the RUN position. Continue to depress the AUTO button until the LED blinks and the high beams turn on, then release the button. Describe what happens.

\_\_\_\_\_

\_\_\_\_\_

\_\_\_\_\_

3. Repeat the steps to enter the demonstration mode again. While the lamps are illuminated during the demonstration mode, slide a piece of cardboard between the camera lens and the windshield. Describe the results.

\_\_\_\_\_

\_\_\_\_\_

Task Completed

4. Use the service information and determine the alignment specification of the camera. Record the specifications.

---

---

5. Connect the scan tool and navigate to the “automatic high-beam module (AHBM).” Locate the camera aim test function and activate the test. Describe the status of the LED.

---

6. What does this indicate?

---

7. Turn off the ignition, and use a tape measure and service information procedures to determine the centerline of the camera lens; mark the windshield and rear glass with a grease pencil.

8. Using a tape measure, determine a location in front of the vehicle that is the specified distance from the vehicle. What is the specified distance? \_\_\_\_\_

9. Locate the calibration target in front of the vehicle, and align it with the marks on the windshield.

10. Using a tape measure, determine the distance the target’s center LED should be from the floor. Record this distance. \_\_\_\_\_

11. Adjust the calibration target to the required height.

12. Turn on the power supply to the calibration target, and then place the ignition switch in the RUN position. Describe the results.

---

---

13. Use the scan tool to determine and record the calibration status.

14. Check for DTCs and record.

---

---

---

15. Clear any DTCs.

Instructor’s Response \_\_\_\_\_

---

---

<b>DIAGNOSTIC CHART 12-1</b>	
PROBLEM AREA:	Concealed headlight system
SYMPTOMS:	Headlight doors fail to open or close
POSSIBLE CAUSES	<ol style="list-style-type: none"> <li>1. Faulty headlight switch</li> <li>2. Power feed to relay or relay module</li> <li>3. Faulty relay or relay module</li> <li>4. Faulty door motor</li> <li>5. Open, short, or high resistance in motor control circuits</li> <li>6. Controller power and ground circuits</li> <li>7. Faulty controller</li> </ol>

<b>DIAGNOSTIC CHART 12-2</b>	
PROBLEM AREA:	Computer-controlled headlight system
SYMPTOMS:	Headlights fail to turn on
POSSIBLE CAUSES	<ol style="list-style-type: none"> <li>1. Faulty headlight switch</li> <li>2. Power feed to relays</li> <li>3. Faulty relay(s)</li> <li>4. Open, short, or high resistance in relay control circuit motor control circuits</li> <li>5. Headlamp circuit failure</li> <li>6. Burned out headlamp elements</li> <li>6. Controller power and ground circuits</li> <li>7. Faulty controller</li> </ol>

<b>DIAGNOSTIC CHART 12-3</b>	
PROBLEM AREA:	Automatic headlight system
SYMPTOMS:	Headlights fail to turn on in automatic mode, headlights work in manual mode
POSSIBLE CAUSES:	<ol style="list-style-type: none"> <li>1. Open input circuit from switch to control module</li> <li>2. Faulty module</li> <li>3. Faulty switch</li> </ol>

<b>DIAGNOSTIC CHART 12-4</b>	
PROBLEM AREA:	Automatic headlight system
SYMPTOMS:	Headlights turn on in daytime when switch is in AUTO mode
POSSIBLE CAUSES:	<ol style="list-style-type: none"> <li>1. Faulty photocell</li> <li>2. Open photocell circuit</li> <li>3. Shorted photocell circuit</li> <li>4. Faulty control module</li> <li>5. Bus communications error</li> <li>6. Immobilizer system inoperative</li> </ol>

<b>DIAGNOSTIC CHART 12-5</b>	
PROBLEM AREA:	Automatic high/low beam
SYMPTOMS:	Headlights fail to automatically switch to high beam
POSSIBLE CAUSES:	<ol style="list-style-type: none"> <li>1. Obstruction in front of camera</li> <li>2. Improper headlight aiming</li> <li>3. System not initialized</li> <li>4. Camera alignment</li> <li>5. System voltage to module</li> <li>6. Module ground circuit</li> <li>7. Bus network failure</li> <li>8. Faulty controller</li> </ol>

<b>DIAGNOSTIC CHART 12-6</b>	
PROBLEM AREA:	Headlight leveling system
SYMPTOMS:	Headlights fail to level properly
POSSIBLE CAUSES:	<ol style="list-style-type: none"> <li>1. Improper headlight aiming</li> <li>2. Faulty switch input or circuit</li> <li>3. Faulty headlight level sensor or sensor circuits</li> <li>4. Disconnected link to headlight level sensor(s)</li> <li>4. Circuits to motor(s)</li> <li>4. Defective motor(s)</li> <li>5. System voltage to module</li> <li>6. Module ground circuit</li> <li>7. Bus network failure</li> <li>8. System not calibrated</li> <li>8. Faulty controller</li> </ol>



<b>DIAGNOSTIC CHART 12-7</b>	
PROBLEM AREA:	Daytime running lights
SYMPTOMS:	DRL fail to turn on
POSSIBLE CAUSES:	<ol style="list-style-type: none"> <li>1. Faulty headlight switch input or circuit</li> <li>2. Power circuit to DRL relay or relay module</li> <li>3. Defective relay or relay module</li> <li>4. Parking brake switch or circuit</li> <li>4. System voltage to module</li> <li>5. Module ground circuit</li> <li>6. Bus network failure</li> <li>7. Faulty controller</li> </ol>

<b>DIAGNOSTIC CHART 12-8</b>	
PROBLEM AREA:	Illuminate Entry System
SYMPTOMS:	Courtesy light fail to turn on
POSSIBLE CAUSES:	<ol style="list-style-type: none"> <li>1. Faulty headlight switch input or circuit</li> <li>2. Faulty door ajar switches or circuits</li> <li>3. Dead battery in remote FOB</li> <li>4. Defective FOB</li> <li>5. Open, short, or high resistance in the lamp driver circuit</li> <li>6. Power circuit to the module</li> <li>7. Defective relay or relay module</li> <li>8. Module ground circuit</li> <li>9. Bus network failure</li> <li>10. Burned out lamp elements</li> <li>11. Faulty controller</li> </ol>

<b>DIAGNOSTIC CHART 12-9</b>	
PROBLEM AREA:	Illuminate Entry System
SYMPTOMS:	Courtesy light fail to turn off
POSSIBLE CAUSES:	<ol style="list-style-type: none"> <li>1. Faulty headlight switch input or circuit</li> <li>2. Faulty door switches or circuits</li> <li>3. Short to ground in the lamp driver circuit</li> <li>4. Power circuit to the module</li> <li>5. Defective relay or relay module</li> <li>6. Module ground circuit</li> <li>7. Bus network failure</li> <li>8. Faulty controller</li> </ol>

*This page intentionally left blank*

# INSTRUMENTATION AND WARNING LAMP SYSTEM DIAGNOSIS AND REPAIR



### BASIC TOOLS

Basic mechanic's tool set

Service information

### UPON COMPLETION AND REVIEW OF THIS CHAPTER, YOU SHOULD BE ABLE TO:

- Remove and replace the instrument cluster.
- Remove and replace the printed circuit.
- Diagnose and repair causes for erratic and inaccurate speedometer readings.
- Diagnose and repair causes for tachometer malfunctions.
- Diagnose and repair faulty gauge circuits.
- Diagnose and repair the cause of multiple gauge failure.
- Diagnose sender units, including thermistors, piezoresistive, and mechanical variable styles.
- Diagnose and repair warning light circuits.
- Diagnose and repair the cause of multiple warning light failures.
- Enter diagnostic mode and retrieve trouble codes from BCM-controlled electronic instrument clusters.
- Perform self-diagnostic tests on the electronic instrumentation system.
- Determine faults as indicated by the self-test.
- Diagnose computer-driven speedometer and odometer instrumentation malfunctions.
- Test magnetic pickup speed sensors.
- Test optical-type speed sensors.
- Determine the cause of constant low gauge readings in computer-controlled instrumentation systems.
- Diagnose and locate the cause for constant high gauge readings in computer-controlled instrumentation systems.

### INTRODUCTION

The instrument panel gauges and warning lamps monitor the various vehicle operating systems and provide information to the driver about their operation. Most problems in the gauges or warning lamps are usually caused by an open circuit in the wiring or the printed circuit; improper gauge calibration; loose connections; excessive resistance; or defective bulbs, gauges, or sending units.

In this chapter you will learn how to diagnose the gauge, lamp, and sending unit of the various styles of conventional instrument panels. You will learn how to remove the instrument panel to replace the printed circuit, and how to repair the speedometer cable core.

This chapter will also introduce you to common service procedures used to diagnose and repair computer-driven instrumentation systems. These systems include the speedometer, odometer, fuel, and engine instrumentation. The computer-driven instrument cluster uses a microprocessor to process information from various sensors and to control the gauge display. Depending on the manufacturer, the microprocessor can be a separate computer that receives direct information from the sensors and makes the calculations, or the body control

module (BCM) is used to perform all functions. The computer may control a digital or a quartz swing needle instrument cluster.

It is out of the scope of any textbook to cover service procedures for every type of instrument cluster. To illustrate, in one model year alone, Chrysler offered two different electronic clusters (Huntsville and Motorola). The Huntsville cluster was available in four different variations, one with a message center, one with a trip computer, and two options that offered tachometers. In addition, the system could also have a twenty-four voice alert function. In the same year, Ford offered five different electronic clusters, and each division of General Motors offered its own electronic instrument cluster. Add to this the many different types of import vehicles that use their own systems. This chapter will familiarize you with general procedures; however, it is important to remember that each system uses its own diagnostic procedures.

Usually the technician will be required to isolate the faulty component and replace it. Most instrument panel components are not repaired or serviced in the shop but sent back to the manufacturer or specialty shop for rebuilding.



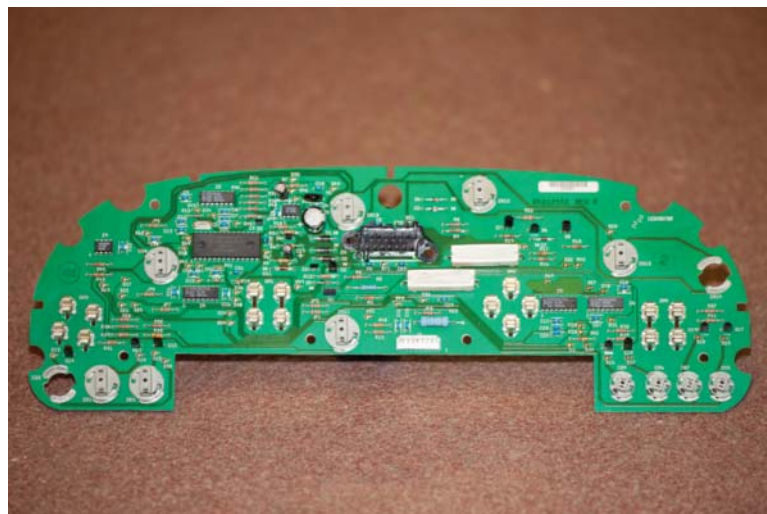
### SPECIAL TOOLS

Fender covers  
Safety glasses  
Battery terminal  
pliers

## INSTRUMENT PANEL AND PRINTED CIRCUIT REMOVAL

Many times it may be necessary to remove the instrument panel to replace defective gauges, lamps, or printed circuits. Before removing the instrument panel, always disconnect the battery negative cable. Consult the service information for the procedure for the vehicle you are working on. The following is a common method of removing the instrument cluster and printed circuit:

1. Place fender covers on the fenders and disconnect the battery negative cable.
2. Remove the retaining screws to the steering column cover. Then remove the cover.
3. Remove the finish panel retaining screws. On some models it may be necessary to remove the radio knobs.
4. Remove the finish panel.
5. Remove the retaining bolts that hold the cluster to the dash.
6. Reach behind the instrument panel and disconnect the speedometer cable.
7. Gently pull the cluster away from the dash.
8. Disconnect the cluster feed plug from the printed circuit receptacle. Be careful not to damage the printed circuit.
9. Remove the IVR and all illumination and indicator lamp sockets (Figure 13-1).
10. Remove the charging system warning lamp resistor if applicable.
11. Remove all printed circuit attaching nuts and remove the printed circuit.



© Delmar/Cengage Learning

FIGURE 13-1 Instrument panel printed circuit board.

## BCM DIAGNOSTICS

The BCM may be capable of running diagnostic checks of the electronic instrument cluster to determine if a fault is present. If the values received from monitored functions are outside of programmed parameters, a DLC is set. This code can be retrieved by the technician to aid in troubleshooting. Depending upon the vehicle, code retrieval is done through the ECC, IPC, jumping terminals in the DLC, or by a scan tool.

To retrieve diagnostic codes in most General Motors vehicles with an electronic climate control (ECC) display, turn the ignition switch to the RUN position and simultaneously press the OFF and WARMER buttons on the climate control panel. ECM codes will be displayed first, followed by BCM codes. The system will display codes twice. The first pass are all codes in memory. Codes that are in the first set but not in the second are history codes. All codes displayed during the second pass are current codes.

After the trouble codes have been retrieved from memory, refer to the proper diagnostic chart to isolate the fault. It is possible for a problem to exist that does not set a trouble code. In these instances, use the symptom or troubleshooting chart in the service information to locate the fault.

Some manufacturers provide a means of overriding the instrument cluster display and change the parameters to allow for testing. By changing the parameters in this test mode, the gauge will change its indicated reading. If the gauge changes its readings correctly, the fault is in the control module.

## SELF-DIAGNOSTICS

Most instrument panel display modules have a diagnostic mode within their programming. The diagnostic mode allows the module to isolate any faults within the instrument panel cluster. In most systems, if the module is not able to complete its self-diagnostic test, the fault is within the module and it must be replaced. Successful completion of the self-diagnostic test indicates the problem is not the module. The following are examples of self-diagnostic procedures.

### Diagnosis of a Typical Electronic Instrument Cluster

All electronic instrument clusters (EICs) are sensitive to static electricity damage and EIC cartons usually have a static electricity warning label. When servicing EICs:

1. Do not open the EIC carton until you are ready to install the component.
2. Ground the carton to a known good ground before opening the package.
3. Always touch a known good ground before handling the component.
4. Do not touch EIC terminals with your fingers.
5. Follow all service precautions and procedures in the vehicle manufacturer's service information.

**Prove-Out Display.** Most EICs have a prove-out display each time the ignition switch is turned on. During this display, all the EIC segments are illuminated and then turned off momentarily (Figure 13-2). The EIC returns to normal display after the prove-out. If the EIC is not illuminated during the prove-out display, check the power supply and grounds to the EIC. If these are good, replace the EIC.

If some of the segments do not illuminate during the prove-out display, the EIC is defective and must be replaced. During the prove-out mode, the turn signal and high-beam indicators are not illuminated. Other indicator lights remain on when the EIC display is turned off momentarily in the prove-out mode. After the prove-out mode is completed, the indicator lights go out shortly after the EIC returns to normal display.

**Function Diagnostic Mode.** The diagnostic procedure for EICs varies depending on the vehicle make and model year. Always follow the diagnostic procedures in the vehicle

### Classroom Manual

Chapter 13,  
page 340, 344



### SPECIAL TOOLS

Scan tool



#### CAUTION:

VFD displays are easily damaged by physical shock. When handling EICs, do not drop or jar them.



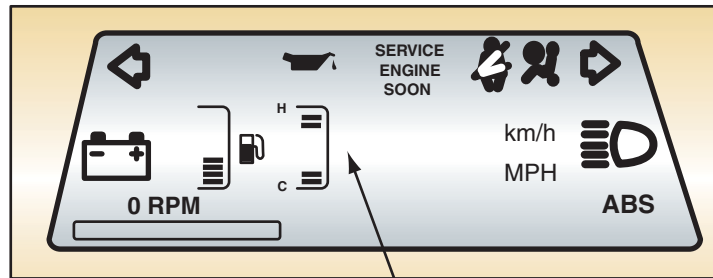
#### CAUTION:


When servicing EICs, follow all service precautions related to static discharge in the vehicle manufacturer's service information to avoid EIC damage.



© Delmar/Cengage Learning

**FIGURE 13-2** All EIC segments are illuminated during the prove-out display.



Engine temperature sensor input short circuited lights two top bars and bottom two bars and extinguishes temperature ISO (  ) symbol and legend

© Delmar/Cengage Learning

**FIGURE 13-3** EIC function diagnostic mode.

manufacturer's service information. Some EICs have a function diagnostic mode that provides diagnostic information in the display readings if certain defects occur in the system. For example, if the coolant temperature sender has a shorted circuit, the two top and bottom bars are illuminated in the temperature gauge and the ISO symbol is extinguished (Figure 13-3). If the engine coolant never reaches normal operating temperature or the coolant temperature sender circuit has an open circuit, the bottom bar in the temperature gauge is illuminated with the ISO symbol.

If the fuel gauge sender develops a short or open circuit, the two top and bottom bars in the fuel gauge are illuminated and the ISO symbol is not illuminated. A shorted fuel gauge sender causes CS to be displayed in the fuel remaining or distance to empty displays. If the fuel gauge sender has an open circuit, CO is displayed in the fuel remaining and distance to empty displays. When the function diagnostic mode indicates short or open circuits in the inputs, the cause of the problem must be located by performing voltmeter and ohmmeter tests in the circuit with the indicated problem. These voltmeter and ohmmeter tests are included in the vehicle manufacturer's service information.

When the word ERROR appears in the odometer display, the EIC computer cannot read valid odometer information from the nonvolatile memory chip.



**Special Test Mode.** Most EICs have a special test mode to determine if the display is working properly. To enter the special test mode, press the E/M and SELECT buttons simultaneously and turn the ignition switch from the OFF to the RUN position. When this action is complete, a number appears in the speedometer display and two numbers are illuminated in the odometer display. The gauges and message center displays are not illuminated. If any of the numbers are flashing in the speedometer or odometer displays, the EIC is defective and must be replaced.

## Diagnosis of a Typical Import Electronic Instrument Cluster

The display check tests for an open circuit in each display segment and shorts between segments. Press and hold trip reset switch A and turn the ignition switch from OFF to RUN to initiate the display check (Figure 13-4). After this action is taken, all the display segments should illuminate, one after the other. If any segment is not illuminated, the EIC must be replaced.

The preprogrammed signal check tests for defects in various displays. To complete the preprogrammed signal check:

1. Disconnect the negative battery cable. If the vehicle is equipped with an air bag, wait the specified time recommended by the vehicle manufacturer.
2. Remove the EIC power unit.
3. Remove the retaining nuts on the EIC switches; then remove the EIC switches.
4. Remove cluster lid; then remove the EIC assembly.
5. Connect the special self-checking wiring harness to the EIC terminals (Figure 13-5).
6. Connect the negative battery cable, turn on the ignition switch, and observe the EIC displays. Each display should change to a specific reading (Figure 13-6). If each display changes as specified by the vehicle manufacturer, the EIC is satisfactory. When some of the displays do not change as specified, voltmeter and ohmmeter tests are required to locate the exact cause of the problem.

After completing the test procedure, turn off the ignition switch and disconnect the negative battery cable. If the vehicle is equipped with an air bag, wait the length of time specified by the vehicle manufacturer. Disconnect the special self-checking wiring harness and connect all EIC connectors securely. Complete installation of the EIC, cluster lid, and switches.

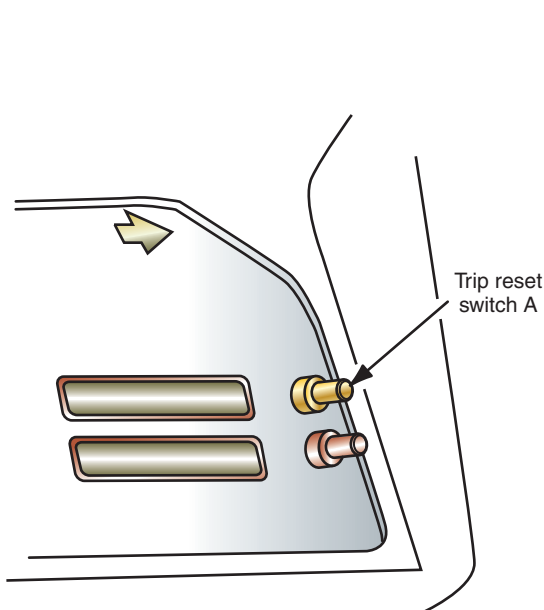


FIGURE 13-4 EIC reset button.

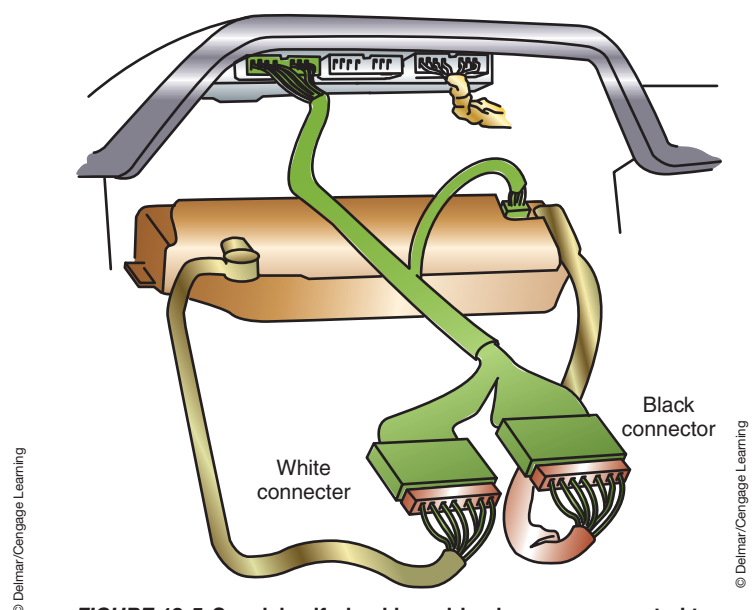
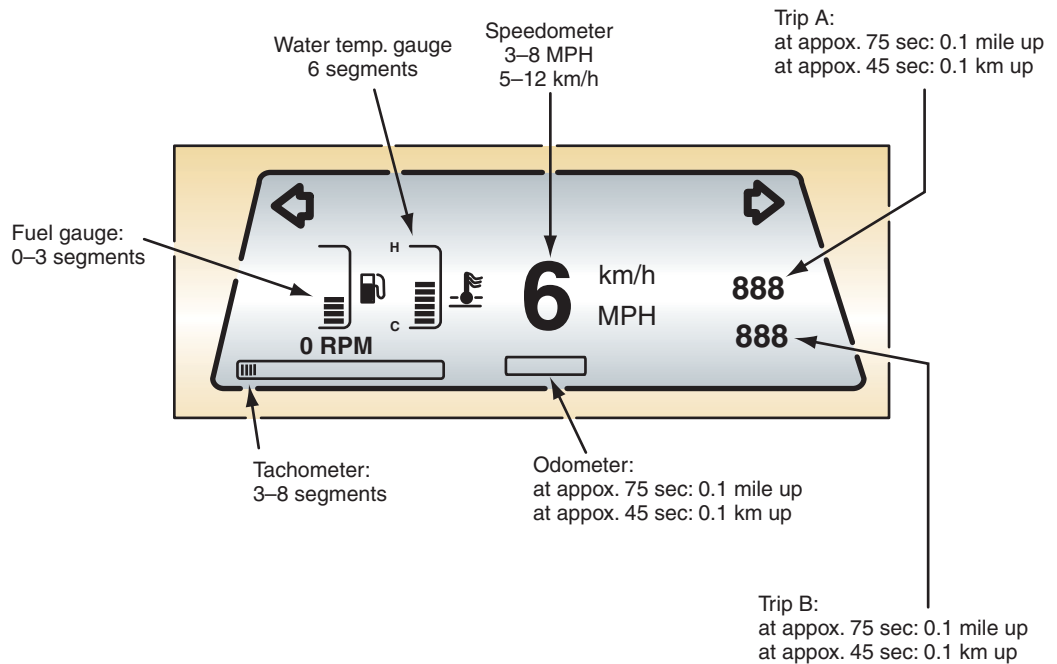


FIGURE 13-5 Special self-checking wiring harness connected to EIC terminal.



© Delmar/Cengage Learning

FIGURE 13-6 Display changes during the preprogrammed signal check.



**WARNING:** If the odometer has been repaired or replaced and it cannot indicate the same mileage as before it was removed, in most areas the law requires that an odometer mileage label must be attached to the left-front door frame. Failure to comply with this procedure could lead to court action.

A defective power unit may cause the EIC displays to be inoperative. The power unit supplies different voltages to various EIC displays. Therefore, it is possible for a defective power unit to cause the failure of specific EIC displays to illuminate.

To perform the power unit test, begin by removing the power unit and leaving the wiring harness connected to the unit. With the ignition switch in the RUN position, test the voltage at the power unit terminals. Each power unit terminal should have the voltage specified by the vehicle manufacturer. The power unit ground wire is connected from terminal 9 to ground. With the ignition switch in the OFF position, connect a pair of ohmmeter leads from power unit terminal 9 to ground. If the meter reading is above 0.5  $\Omega$ , repair the ground wire. If the power unit does not have the specified voltage at some of the terminals, replace the unit.

A defective speed sensor may show an inoperative or erratic speedometer reading. To test the speed sensor, begin by removing the cluster lid to gain access. Connect a pair of voltmeter leads to terminals 11 and 1 on the EIC with the wiring harness connected (Figure 13-7). Turn the ignition switch to the RUN position and check the voltmeter reading. If the voltage is zero, check the power unit. If voltage is present, turn off the ignition switch and disconnect the speedometer cable from the speed sensor. Remove the wiring harness connector containing terminals 1 and 12 from the EIC and connect an analog voltmeter's leads to terminals 1 and 12. Use a small screwdriver to slowly rotate the speed sensor (Figure 13-8). If the voltmeter pointer does not deflect, the speed sensor or the connecting wires are defective. Connect the voltmeter leads directly to the speed sensor terminals and rotate the speed sensor again. If the voltmeter pointer deflects, repair the wires between the speed sensor and EIC terminals 1 and 12. If the voltmeter pointer does not deflect, replace the speed sensor.



### SERVICE TIP:

While testing the speed sensor, slowly turn the sensor with a small screwdriver. The sensor produces 24 signals per revolution, which are difficult to read during fast sensor rotation.

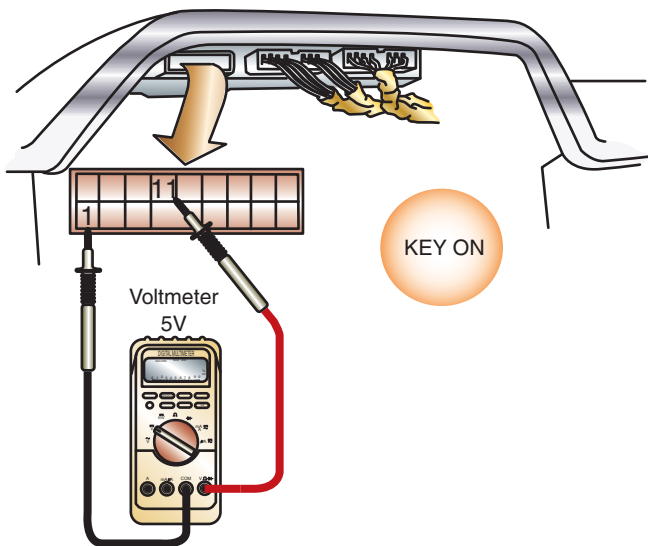


FIGURE 13-7 Voltmeter connections to EIC terminals.

© Delmar/Cengage Learning

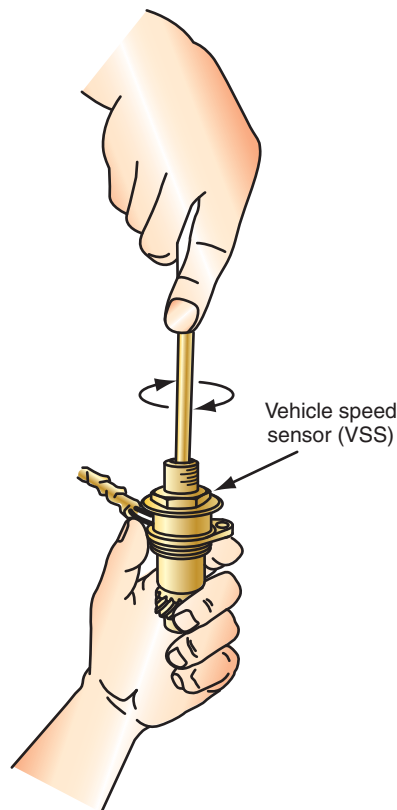


FIGURE 13-8 Testing the speed sensor.

© Delmar/Cengage Learning

## Chrysler Electromechanical Cluster Self-Test

Many electromechanical clusters (MIC) can be tested with or without a scan tool. Usually a self-test of the cluster can be performed. This test does not check any of the inputs—only the cluster. As an example of this system, a Chrysler mini-van is used. However, diagnostics of most MICs is similar.

To enter self-diagnostics, the ignition key must be in the LOCK position. Push and hold the TRIP and RESET buttons on the cluster at the same time. While continuing to hold these buttons, turn the ignition switch to the RUN position. Note that the cluster will illuminate in the UNLOCK position but will not activate self-diagnosis. Continue to hold the two buttons until CODE is displayed in the odometer. Release the buttons. If there are any fault codes, they will be displayed in the odometer. A code 999 means there are no faults. If fault codes are present, use the correct diagnostic manual to diagnose the system.

After the codes are displayed, the cluster will go through a series of tests as follows:

- Check 0. Tests all of the VF display segments in the odometer and PRND3L. All segments should be illuminated.
- Check 1. Tests the operation of all gauges. The gauge swing needles will move to programmed values.
- Check 2. Illuminates each odometer VF segment individually.
- Check 3. Tests the PRND3L display.
- Check 4. Illuminates all of the warning lamps that are controlled by the MIC.

Observe operation of the MIC during each test. If any of these tests fail proper operation, the MIC must be replaced.



### SPECIAL TOOLS

Scan tool

An additional feature of this cluster is that the technician can calibrate the gauges. This requires the use of Chrysler's scan tool. The following steps provide a guide to recalibrating the speedometer. All gauges are calibrated in the same manner.

1. Plug the scan tool cable into the DLC. The ignition switch does not need to be in the RUN position. However, the bus must be active. Opening a door will awake the BCM.
2. Once the scan tool powers up and displays the MAIN MENU.
3. Select BODY.
4. Select ELECTRO/MECH CLUSTER from the BODY menu.
5. Select MISCELLANEOUS.
6. Select CALIBRATE GAUGES.
7. The scan tool will ask if the cluster has a tachometer. Answer with the YES or NO key.
8. The scan tool will ask if the vehicle is a diesel. Answer with the YES or NO key.
9. The scan tool will ask if the cluster units are in MPH. Answer with the YES or NO key.
10. Place the ignition switch into the UNLOCK position.

This will place the scan tool in the mode to run gauge calibration. The first gauge to be calibrated will be the speedometer. The scan tool screen will display that it is sending a signal to the MIC to set the mph at 0. If the needle is not aligned with the 0, then use the up or down arrow keys to move the needle until it is aligned. Once the gauge is calibrated to 0, press the enter key and the scan tool will move to the next calibration unit. The next unit is 20 mph. Follow the same procedure to align the needle with the 20-mph mark on the cluster. After each calibration, press the enter key to move to the next unit. The other calibration units are 55 and 75 mph.

The tachometer, fuel, and temperature gauges are calibrated in the same manner. Once all of the gauges are calibrated, the scan tool will instruct the MIC to write the new values to memory.

## Ford Electronic Cluster Self-Diagnostic Test

The electronic cluster is capable of indicating a fault and providing an explanation of the cause. Use the illustration (Figure 13-9) as a guide to the function of the gauges when in diagnostic mode. Use the gauge display to determine the nature of the fault. Then refer to the service information for diagnostic charts to locate the problem.

## SPEEDOMETER DIAGNOSIS AND REPAIR

Speedometer complaints range from chattering noises when cold, to inaccurate readings, to not operating at all. Diagnosis and repair of the speedometer depends on the type, conventional or electronic.

### Conventional Speedometer

In instrument clusters that use conventional speedometers, often the problem of noise, erratic, or inaccurate readings can be corrected by lubricating the cable with an approved lubricant. If the cable is dry, it will bind as it attempts to rotate in the housing. However, the cause of the noise must be isolated since just applying lubricant may only stop the noise temporarily. It is a good practice to remove the cable core to clean and inspect it before adding lubricant. If the cable is well lubricated and the problem is still present, check the condition of the speedometer drive gear. If the cable and the gears are not the problem, the speedometer head may be faulty and need to be replaced.

The conventional speedometer uses **eddy currents** (small induced currents) instead of a direct mechanical connection from the cable to the speedometer head. If the cause of the noise is not in the cable, the bushings in the head may be worn. This would allow the cup and magnet to come in contact and result in noisy operation and inaccurate readings. In this case the speedometer head will have to be replaced.






### Classroom Manual

Chapter 13, page 339



### SPECIAL TOOLS

Fender covers  
Safety glasses  
Battery terminal pliers  
Terminal pliers

Oil gauge	 H N o r m L	Oil pressure sensor input short circuited light top 2 bars and bottom 2 bars and extinguishes oil can ISO symbol	 H N o r m L	Low oil pressure warning or oil pressure sensor input open circuited lights bottom bar and flashes ISO symbol
Temp gauge	 H N o r m C	Engine temperature sensor input short circuited lights top 2 bars and bottom 2 bars and extinguishes ISO symbol	 H N o r m C	Cold engine temperature indication or engine temperature sensor input open circuited lights bottom bar and ISO symbol
Fuel gauge	 H N o r m L	Fuel level sender input short circuited or open lights top 2 and bottom 2 bars and extinguishes ISO symbol	CO CS	Fuel level sender input short or open circuited displays "CS" (short) or "CO" (open) in driver information center
Odometer	55 ERROR			Odometer malfunction displays ERROR in odometer display
Fuel computer	FFS			Fuel flow signal short or open circuited displays FFS in driver information center

**FIGURE 13-9** Gauge readout indicates the nature of the fault when the system is in the diagnostic mode.

To remove the cable core, disconnect the speedometer cable assembly from the back of the speedometer head. For most vehicles, this is done by reaching behind the instrument panel and pressing down on the flat surface of the plastic quick connect. On some vehicles, it may be necessary to remove the instrument panel to gain access to the speedometer cable. With the cable assembly disconnected from the speedometer, visually inspect the cable for kinks or other damage. Raise the drive wheels from the ground and start the engine. Place the transmission in gear and allow the drive wheels to rotate at engine idle. Observe the cable rotation inside of the housing; it should be smooth and constant. Shut off the engine; be sure to apply the brakes to stop transmission movement before attempting to return the shift lever to the PARK position.

It may be possible to remove the core by pulling it out of the housing. If the core cannot be removed in this way, disconnect the speedometer retainer from the transaxle (Figure 13-10). Pull the core out of the speed sensor.

With the cable core removed from the housing, clean it with solvent and wipe it dry. Place the core on a flat surface and stretch it out straight. Roll it back and forth while looking for signs of kinks or other damage. If the core is damaged, it must be replaced.

When installing the cable to the speedometer head, apply a small amount of approved lubricant to the drive hole. Check that the speedometer cable takes virtually no change of direction for at least 5 inches (127 mm) from the speedometer head.

**CUSTOMER CARE!** The speedometer cable should be lubricated every 10,000 miles. This practice will reduce speedometer cable problems that will cause noisy, erratic, or inaccurate readings.



### CAUTION:

It is possible to short out wires while reaching behind the instrument panel. Disconnect the battery negative cable before removing the speedometer cable assembly.



### CAUTION:

Do not allow the drive wheels to rotate faster than 50 mph. Since only one wheel will rotate, one of the differential side gears is remaining stationary as the pinion gears "walk" around it. Excessive speed may result in differential damage.



### CAUTION:

Changing tire size and differential gear ratios from original equipment specifications will result in speedometer inaccuracy. In some states it is illegal to calibrate the speedometer unless it is performed by a shop that is qualified to perform this task.



### CAUTION:

Federal and state laws prohibit the tampering with the correct mileage as indicated on the odometer. If the odometer must be replaced, it must be set to the reading of the original odometer, or a door sticker must be installed indicating the reading of the odometer when it was replaced (Figure 13-11).

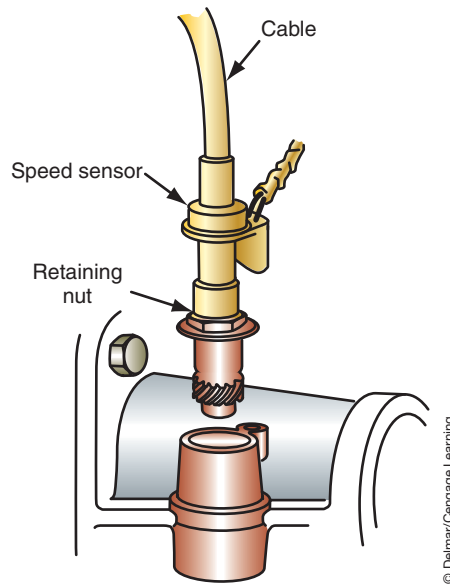
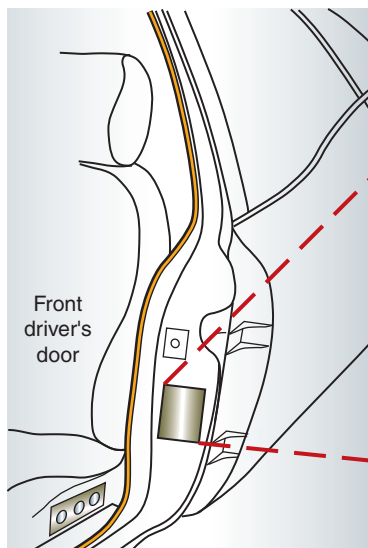


FIGURE 13-10 Speedometer connection at the transaxle.



<b>ODOMETER REPAIR/REPLACEMENT</b>
The odometer on this vehicle was repaired and turned back to zero, or was replaced with an odometer set at zero miles.
Mileage prior to repair or replacement was: _____ miles or _____ kilometers.
Date repaired or replaced: _____
By: _____
Federal law prohibits removal or alteration of this label.

FIGURE 13-11 An odometer repair label.

### Classroom Manual

Chapter 13, page 345

### Classroom Manual

Chapter 13, pages 339, 343, 345

If the speedometer assembly must be replaced, usually a new **odometer** is included with the assembly. The odometer is a mechanical counter in the speedometer unit that indicates total miles driven by the vehicle. Be sure to follow the manufacturer's procedures for setting the odometer to the correct reading.

## Electronic Speedometers and Odometers

Diagnosis of the sending units and input circuits to the gauges of electromechanical instrument clusters typically follow normal testing procedures. The following is an example of diagnosing the **quartz swing needle** electronic speedometer and odometer gauges of an electromechanical cluster (Figure 13-12). Computer-driven quartz swing needle displays



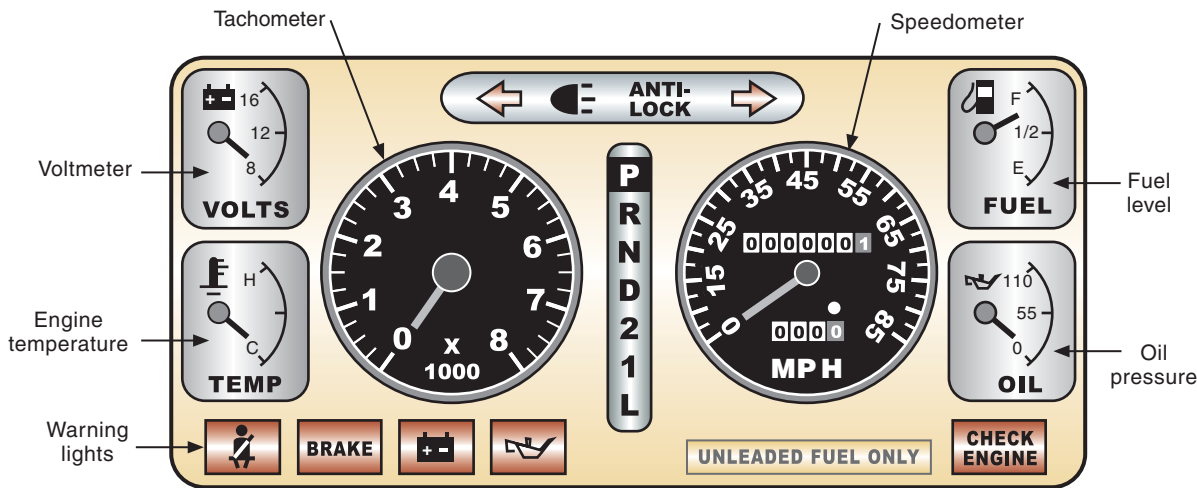


FIGURE 13-12 Quartz swing needle speedometer used with conventional gauges.

© Delmar/Cengage Learning

are similar in design to the air-core electromagnetic gauges used in conventional analog instrument panels.

On most systems, the odometer and speedometer receive their input from the vehicle speed sensor. If there is a fault with the speed sensor, other systems (such as cruise control) will also be affected. When test driving the vehicle, attempt to activate the cruise control system to determine if it is operating properly. If the cruise control system fails, the problem can be the speed sensor, its circuit, BCM, or the ECM.

Some systems may provide for replacement of the stepper motor or odometer chip separate of the cluster. Always refer to the service information for the vehicle being diagnosed.

Generally, if the BCM and/or cluster module pass their self-diagnostic tests, the fault will be in the speed sensor circuit. Common test procedures for the speed sensor are presented later in this chapter.

If the speedometer is not operating, but the odometer works properly, the fault is in the instrument cluster. Likewise, if the speedometer operates but the odometer fails, the fault is in the cluster. In either case the cluster must be replaced. If the speedometer and/or odometer are inaccurate, or both do not operate, check the following items:

1. If the system uses an optical vehicle speed sensor, check the speedometer cable for kinks, twists, or other defects that will cause an inaccurate reading.
2. See if there are shorts in the wiring circuit of the speed sensor.
3. Make sure of proper gear ratio and tire size. Both of these items will affect correct speedometer and odometer operation. Changing tire size from that intended by the manufacturer has the same effect as changing gear ratios in the differential.

If the speedometer and/or odometer display illuminates but remains at zero (or any other digit)—or operates erratically or intermittently—check the connector at the speed sensor for proper installation and corrosion. Next, check the wiring circuit for any shorts or opens. If these tests do not isolate the problem, the speed sensor should be tested. Testing of the speed sensor will depend on the type of sensor used.

**Magnetic Pickup Speed Sensor Testing.** Disconnect the wire connector at the vehicle speed sensor. With the ignition switch placed in the RUN position, use a jumper wire to make and break the connection between the two wires (Figure 13-13). This should cause the speedometer display to change. Change the rate of speed at which you make and break the connection and the display should indicate the changes in speed. The faster you make and break the connection, the higher the speedometer reading.



## SPECIAL TOOLS

Scanner  
DMM

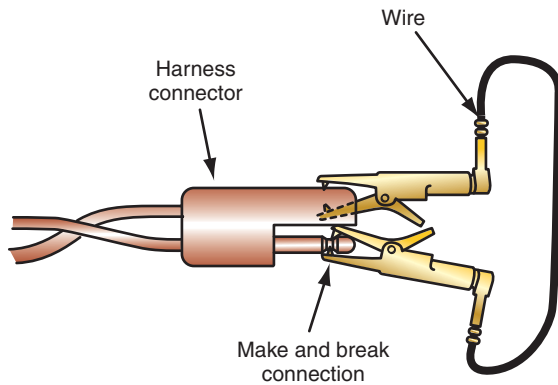


## SERVICE TIP:

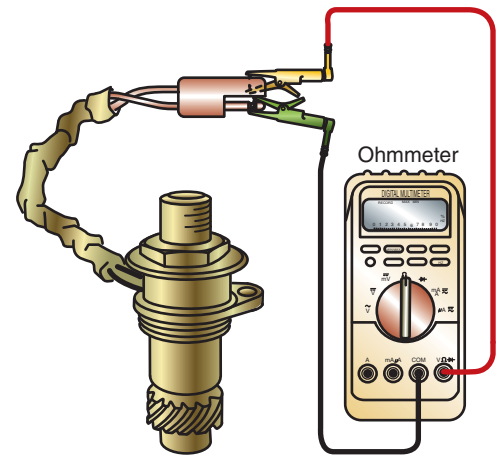
If the electronic speedometer uses a cable-driven sensor, the cable may be serviced as described in the previous section.

## Classroom Manual

Chapter 13, page 339



**FIGURE 13-13** Testing the magnetic pick-up speed sensor circuit. Making and breaking the connection should produce a reading in the speedometer window.



**FIGURE 13-14** Using an ohmmeter to test the speed sensor.



### SPECIAL TOOLS

Jumper wires  
Ohmmeter  
Lab scope

### Classroom Manual

Chapter 13, page 343



### SERVICE TIP:

A reversible, variable speed drill can be used to rotate the speedometer cable if you are sure there are no twists or kinks in the cable.

### Classroom Manual

Chapter 13, page 345

If there is no change in the speedometer display, check for opens and shorts in the sensor circuit. If the cluster passed its self-test (and you did not skip any steps) this is the only area in which the fault can be located.

If the speedometer changed speeds, the problem is in the speed sensor. To test the speed sensor, remove it from the transaxle. Connect an ohmmeter to the connector terminals of the sensor and select the lowest scale (Figure 13-14). Rotate the sensor gear while observing the ohmmeter. Distinct pulses should be detected on the ohmmeter. Compare the number of pulses per revolution with specifications. Also, compare the resistance value with specifications. If the number of pulses and resistance values are within specifications, the sensor is good.

**Optical Speed Sensor Testing.** Disconnect the speedometer cable at the transaxle and rotate the cable in its housing as fast as possible. If the speedometer display operates properly, check the speedometer pinion and drive gear for damage.

If there is no speedometer operation, check for a broken speedometer cable. This can usually be determined by feeling for resistance while turning the cable by hand. Little resistance indicates a broken cable. Excessive resistance indicates a damaged cable or sensor head.

If the cable is good, the problem is in the sensor or in the wiring between the sensor and the speedometer. Follow the manufacturer's procedure for removing the instrument cluster. Connect a DMM to read the pulsed speed signal from the sensor (Figure 13-15). Rotate the speedometer cable while observing the voltmeter. Compare the pulses per revolution and pulse output values with specifications. Replace the sensor if the values are not within specifications.

**Hall-Effect Switches.** In Chapter 10, the operation of the Hall-effect switch was covered. As discussed, using a lab scope will provide a fast and accurate test of the switch. Refer to Chapter 6 for the test procedures of this type of speed sensor.

**CUSTOMER CARE:** Often inaccurate speedometers are caused by improper tire sizes being used on the vehicle. The larger the tire diameter over original equipment, the slower the speedometer will read. Not all manufacturers provide for entering different tire sizes into the computer, and aftermarket "black boxes" may be illegal to install, depending on state and local ordinances. In most cases, it is in the customer's best interest to keep original equipment size tires on the vehicle.

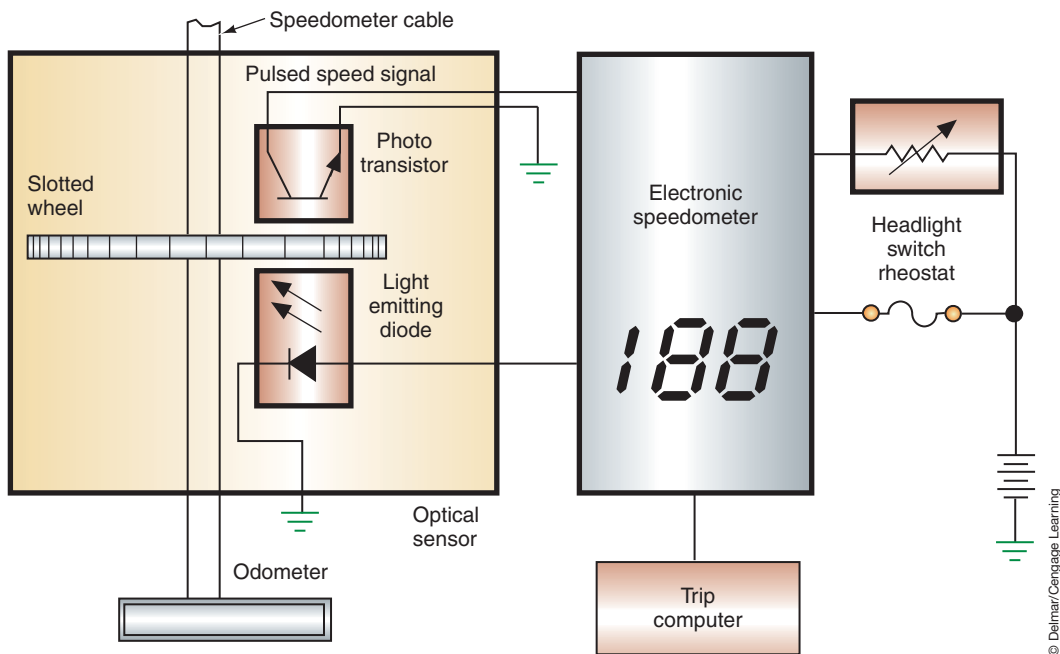


FIGURE 13-15 Optical speed sensor circuit.

## TACHOMETER

The **tachometer** is a gauge instrument used to display the speed of the engine in revolutions per minute (rpm). Most electrically operated tachometers receive their reference pulses from the ignition system. Figure 13-16 illustrates a troubleshooting chart to use as a guide to diagnosing the electrically operated tachometer. If the tachometer is faulty, it must be replaced; there is no servicing the meter itself.

Computer-driven tachometers receive their signals from the crankshaft position sensor (CKP). If the tachometer is not functioning, but the engine starts, check the circuit from the sensor to the instrument cluster. If the instrument cluster receives the signal from the data bus, use the scan tool to determine if the signal is being sent correctly. Usually the CKP sensor is monitored by the PCM, then sent on the data bus. If the message is sent to the BCM, then to the instrument cluster, check the input message to both modules. If the bus message is being sent properly, the problem is the gauge or the instrument cluster. Perform the self-diagnostic test, or scan tool activation test, for the tachometer. If the tachometer fails to operate during this test, replace the gauge or cluster. Some manufacturers do not allow for individual gauge replacement; in such cases, the entire instrument cluster must be replaced.

## CONVENTIONAL INSTRUMENT CLUSTER GAUGE DIAGNOSIS

A **gauge** is a device that displays the measurement of a monitored system by the use of a needle or pointer that moves along a calibrated scale. The sender unit is the sensor for the gauge. It is a variable resistor that changes resistance values with changing monitored conditions.

The instrument voltage regulator (IVR) provides a constant voltage to the gauge regardless of the voltage output of the charging system. The gauge is called an electromechanical device because it is operated electrically, but its movement is mechanical.

With the exception of the voltmeter and ammeter, all electromechanical gauges (whether **bimetallic** or **electromagnetic gauges**) use a variable resistance sending unit. Bimetallic gauges (or thermoelectric gauges) are simple dial and needle indicators that transform the heating effect of electricity into mechanical movement. Electromagnetic gauges produce needle movement by magnetic forces instead of heat. The types of tests performed will depend on the nature of the problem and if the system uses an IVR.

### Classroom Manual

Chapter 13, page 347



### SPECIAL TOOLS

DMM  
Scan tool

### Classroom Manual

Chapter 13, page 335



### CAUTION:

These gauges are called analog because they use needle movement to indicate current levels. However, many modern instrument panels use computer-driven analog gauges that operate under different principles. It is important that the technician follow the manufacturer's procedures for testing the gauges or gauge damage will result.

### TACHOMETER INOPERATIVE, ERRATIC, WRONG OPERATION

Test step	Result	Action to take
1. <b>Check OPERATION</b> Check tachometer operation	<del>OK</del> OK	Go to 2.  Test complete. Check for intermittent operation.
2. <b>Check fuse</b> Check tachometer fuse	<del>OK</del> OK	Replace fuse and determine cause.  Go to 3.
3. <b>Check wiring</b> Check connections and wiring in engine compartment and at instrument cluster	<del>OK</del> OK	Repair connections or wiring.  Go to 4.
4. <b>Check resistance and voltage</b>  Disconnect battery.  Remove instrument cluster and make resistance and voltage checks at lower wire harness connector as follows: (1) Check pin 5 resistance to ground. Should read 1Ω or less. (2) Check pin 17 resistance to negative terminal of ignition coil. Should read 15Ω or less. (3) Connect battery. Turn ignition switch to RUN position. Check for +12V at pin 14. Turn ignition off and disconnect battery.	<del>OK</del> OK	Repair wiring for open or high resistance.  Go to 5.
5. <b>Check fasteners</b>  Check for loose fasteners on rear of instrument cluster, or damaged printed circuit	<del>OK</del> OK	Tighten fasteners / Replace printed circuit  Replace tachometer

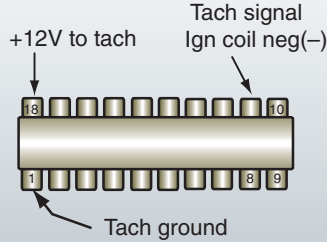


FIGURE 13-16 Troubleshooting chart for testing the tachometer.

© Delmar/Cengage Learning



### SPECIAL TOOLS

- 12-volt test light
- 10-ohm resistor
- 73-ohm resistor
- Fender covers
- Safety glasses

### Single Gauge Failure

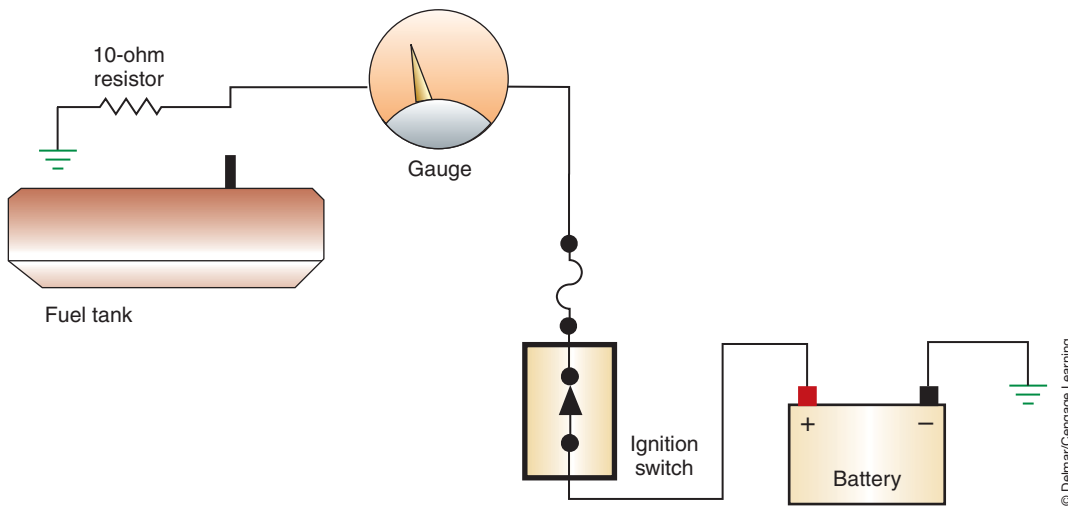
If the gauge system does not use an IVR, check the gauge for proper operation as follows:

1. Check the fuse panel for any blown fuses. The gauge that is not operating may share a fuse with some other circuit that is separate from the other gauges.
2. Disconnect the wire connector from the sending unit of the malfunctioning gauge.



### SERVICE TIP:

It is common for the fuel gauge sender unit to get corrosion on the ground wire connection. Before replacing the sending unit, clean the ground connections and test for proper operation.



**FIGURE 13-17** Testing gauge operation by putting the gauge lead to ground through a resistor. The resistor is used to protect the circuit.

3. Check the terminal connectors for signs of corrosion or damage.
4. Use a test light to confirm that voltage is present to the connector with the ignition switch in the RUN position. If the test light does not illuminate, check the circuit back to the gauge and battery.
5. Connect a 10-ohm resistor in series with the lead from the gauge to the sending unit. Connect the lead to ground (Figure 13-17).
6. With the ignition switch in the RUN position, watch the gauge. Depending on the gauge design, the needle should indicate either high or low on the scale. Check the service information for the correct results.
7. Remove the 10-ohm resistor and replace with a 73-ohm resistor between the sensor lead and ground. Repeat step 6.
8. If the test results are in the acceptable range, the sending unit is faulty.
9. If the gauge did not operate properly in steps 5 and 7, check the wiring to the gauge. If the wiring is good, replace the gauge.

If the gauge circuits use an IVR, follow steps 1 through 4 as described. The test light should flicker on and off. If it did not illuminate, reconnect the sending unit lead and check for voltage at the sender unit side of the gauge (Figure 13-18). If there is voltage at this point, repair the circuit between the gauge and the sending unit. If voltage is not shown, test for voltage at the battery side of the gauge. If voltage is present at this point, the gauge is defective and must be replaced. If no voltage is present at this terminal, continue to check the circuit between the battery and the gauge.

If the IVR was working properly and voltage was present to the sender unit, follow steps 5 through 9.

## Multiple Gauge Failure

If all gauges fail to operate properly, begin by checking the circuit fuse. Test for voltage to the fuse. If voltage is not present at this point, the fault is between the fuse and the battery. Remember, most systems supply battery voltage to the instrument panel gauges through the ignition switch. If voltage is present at the fuse, then continue through the circuit by testing for voltage at the last common circuit point (Figure 13-19). If voltage is not present at this point, work toward the fuse to find the fault. Keep in mind that this common connection point may be on the printed circuit board. If this is the case, test for voltage at the instrument panel connector first.



### SPECIAL TOOLS

12-volt test light  
10-ohm resistor  
73-ohm resistor  
Fender covers  
Safety glasses

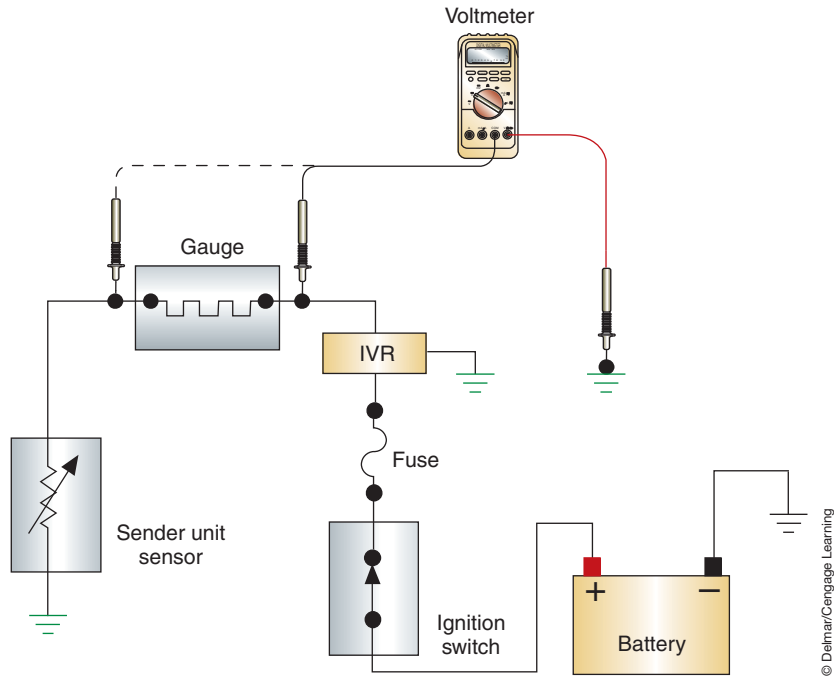


FIGURE 13-18 Checking for regulated voltage on the sender unit side of the gauge.

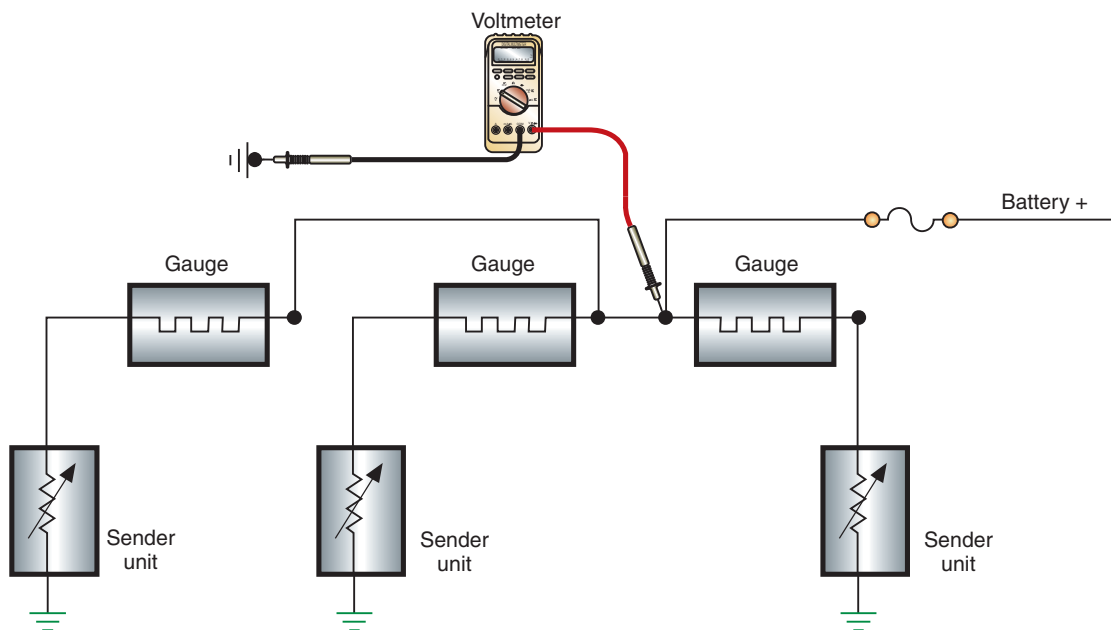


FIGURE 13-19 Check the last common connection in the circuit for voltage.



**SERVICE TIP:**

It is unlikely that all of the gauges would fail at the same time. If the diagnostic tests indicate that the gauges are defective, bench test the gauges before replacing them. Use an ohmmeter to check the resistance. Most electromagnetic gauges should read between 10 and 14 ohms. On systems that do not use an IVR and all of the gauges are defective, check the charging system for excessive output.

If the system uses an IVR, use a voltmeter to test for regulated voltage at a common point to the gauges (Figure 13-20). If the voltage is out of specifications, check the ground circuit of the IVR. If that is good, replace the IVR. If there is no voltage present at the common point, check for voltage on the battery side of the IVR. If voltage is present at this point, then replace the IVR. If battery voltage is not present on the battery side of the IVR, the problem is in the circuit between the fuse and the IVR.



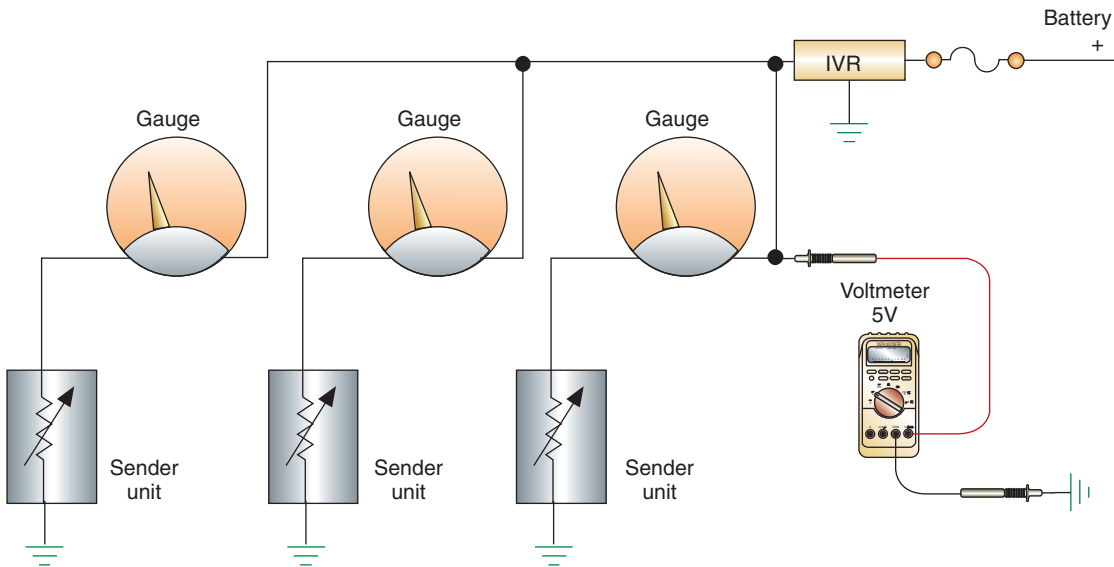


FIGURE 13-20 Testing for correct IVR operation.

© Delmar/Cengage Learning

If regulated voltage is within specifications, test the printed circuit from the IVR to the gauges. If there is an open in the printed circuit, replace the board.

## ELECTRONIC GAUGE DIAGNOSIS

The following are guidelines for testing the individual gauges for proper operation. These tests are to be conducted after the self-diagnostic test indicates there is no problem with the cluster or the module. Test procedures will vary between manufacturers. To properly troubleshoot the gauges, you will need the manufacturer's diagnostic procedure, specifications, and circuit diagram.

### Gauge Reads Low Constantly

A gauge that constantly reads low when the ignition switch is in the RUN position indicates an open in the gauge circuit. To locate the open, follow these steps:

1. Disconnect the wire harness from the sending unit.
2. Connect a jumper wire between the wire circuit from the gauge and ground.
3. Turn the ignition switch to the RUN position. The gauge should indicate maximum.

If the gauge reads high, check the sending unit ground connection. If the ground is good, the sending unit is faulty and must be replaced.

If the gauge continues to read low, follow the circuit diagram for the vehicle being serviced to test for opens in the wire from the sending unit. If the circuit is good, test the control module following recommended diagnostic procedures.

### Gauge Reads High Constantly

A gauge that reads high when the ignition switch is placed in the RUN position indicates there is a short to ground in the circuit. To test the circuit, disconnect the wire harness at the gauge sending unit. Place the ignition switch in the RUN position while observing the gauge. If the gauge reads low, the sending unit is faulty and needs replacement.

If the gauge continues to read high, use the circuit diagram to test for shorts to ground in the circuit from the sending unit. If the circuit is good, test the control module following recommended diagnostic procedures.

## Classroom Manual

Chapter 13,  
page 339, 342



## SPECIAL TOOLS

Jumper wires



## SERVICE TIP:

Although some service information procedures do not require it, it is a good practice to connect a 10-ohm resistor into the jumper wire when performing these tests. This prevents a nonresistive short to ground, yet does not noticeably affect gauge operation.

## Inaccurate Gauge Readings

Inaccurate gauge readings are usually caused by faulty sending units. To test the operation of the gauge, you will need the manufacturer's specifications concerning resistance values as they relate to gauge readings. Gauge testers are available to test the units as different resistance values are changed.

Other reasons for inaccurate gauge readings include poor connections, **resistive shorts**, and poor grounds. Resistive shorts are shorts to ground that pass through a form of resistance first. Also, look for damage around the sending unit. For example, a damaged fuel tank can result in inaccurate gauge readings.

### Classroom Manual

Chapter 13,  
pages 341, 348



### SPECIAL TOOLS

DMM  
12-volt test light  
Fender covers  
Safety glasses  
Shop oil pressure gauge

## GAUGE SENDING UNITS

There are three types of sending units associated with electromechanical gauges: a **thermistor**, a piezoresistive sensor, and a mechanical variable resistor. Most of these can be tested before replacement to confirm the fault.

The fuel level sending unit can be tested in or out of the tank. If it is tested in the tank, add and remove fuel to change the level. The easiest method is to bench test the unit. Photo Sequence 23 illustrates how to bench test a mechanical variable resistor sending unit.

To test the coolant temperature sensing unit, use an ohmmeter to measure the resistance between the terminal lead and ground (Figure 13-21). The resistance value of the variable resistor should change in proportion to coolant temperature. Check the test results with manufacturer specifications.

To test a **piezoresistive sensor** sending unit used for oil pressure gauges, connect the ohmmeter to the sending unit terminal and ground (Figure 13-22). Check the resistance with the engine off and compare to specifications. Start the engine and allow it to idle. Check the resistance value and compare to specifications. Before replacing the sending unit, connect a shop oil pressure gauge to confirm that the engine is producing adequate oil pressure.

## WARNING LAMPS

A warning light may be used to warn of low oil pressure, high coolant temperature, a defective charging system, or a brake failure. Unlike gauge sending units, the sending units for a warning light are nothing more than simple switches. The style of switch can be either normally open or normally closed, depending on the monitored system.

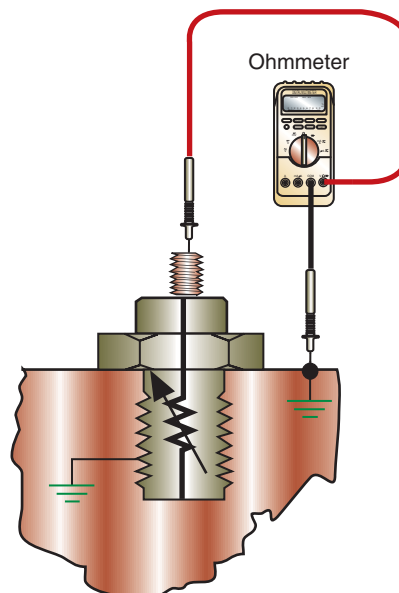
### Classroom Manual

Chapter 13, page 353



### SPECIAL TOOLS

Jumper wires  
Scan tool

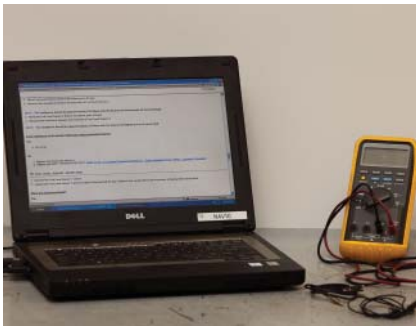


© Delmar/Cengage Learning

FIGURE 13-21 Testing a thermistor with an ohmmeter.

## BENCH TESTING THE FUEL LEVEL SENDER UNIT

All photos in this sequence are © Delmar/Cengage Learning.



**P23-1** Tools required to perform this task: DMM, jumper wires, and service information.



**P23-2** Select the ohmmeter function of the DMM.



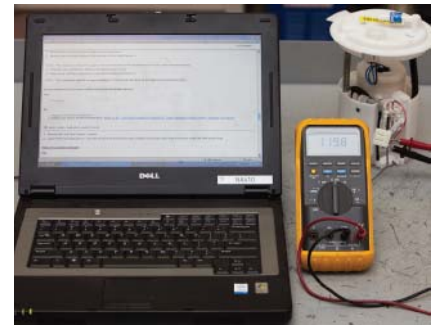
**P23-3** Connect the negative test lead DMM to the ground terminal of the sender unit.



**P23-4** Connect the positive test lead to the variable resistor terminal.



**P23-5** Holding the sender unit in its normal position, place the float rod against the empty stop.



**P23-6** Read the ohmmeter and check the results with specifications.



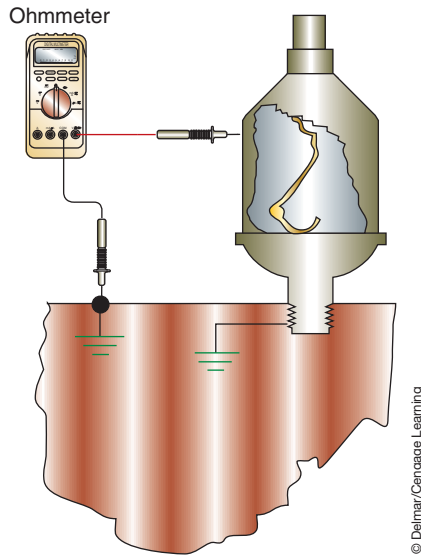
**P23-7** Slowly move the float toward the full stop while observing the ohmmeter. The resistance change should be smooth and consistent.



**P23-8** Check the resistance value while holding the float against the full stop. Check the results with specifications.



**P23-9** Check the float that it is not filled with fuel, distorted, or loose.



**FIGURE 13-22** Using an ohmmeter to test a piezoresistive sensor.

It is not likely that all of the warning lights would fail at the same time. Check the fuse if all of the lights are not operating properly. Next, check for voltage at the last common connection. If voltage is not present, then trace the circuit back toward the battery. If voltage is present at the common connection, test each circuit branch in the same manner as described here for individual lamps.

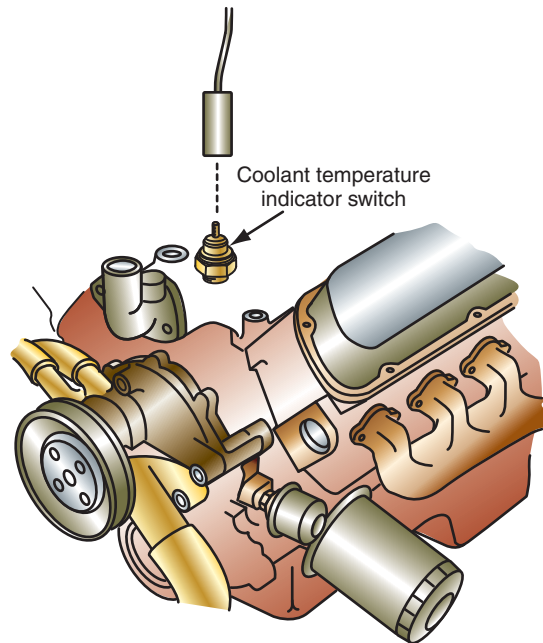
To test a faulty warning lamp on a system with a normally open switch (sending unit), turn the ignition switch to the START position. The **prove-out circuit** should light the warning lamp. A prove-out circuit completes the warning light circuit to ground through the ignition switch when it is in the START position. The warning light will be on during engine cranking to indicate to the driver that the bulb is working properly. If the light does not come on during the prove-out, disconnect the sender switch lead (Figure 13-23). Use a jumper wire to



**SERVICE TIP:**

With the bulbs used for most warning light circuits, it is hard to determine whether or not the filament is good. When a test procedure requires that a bulb be checked, it is usually easier to replace the bulb with a known good one.

If the customer states that the oil pressure light does not go out after the engine is started, use a shop oil pressure gauge to confirm adequate oil pressure.



**FIGURE 13-23** Coolant temperature sensor switch and lead.

connect the sender switch lead to ground. With the ignition switch in the RUN position, the warning lamp should light. If the lamp is illuminated, test the prove-out circuit for an open. If the light does not come on, either the bulb is burned out or the wiring is damaged. Use a test light to confirm voltage is present at the sensor terminal connector. If there is voltage, the bulb is probably bad. If voltage is not present to the sending unit, the bulb may be burned out. At this point, the instrument cluster will need to be removed. With the cluster removed, check for battery voltage to the panel connector. If voltage is present, substitute a known good bulb and test again.

If the system uses a normally closed switch, test in the same manner. However, there will not be a separate prove-out circuit.

If the customer states that the warning light stays on, test in the following manner: Disconnect the lead to the sender switch. The light should go out with the ignition switch in the RUN position. If it does not, there is a short to ground in the wiring from the sender switch to the lamp. If the light goes out, replace the sender switch.

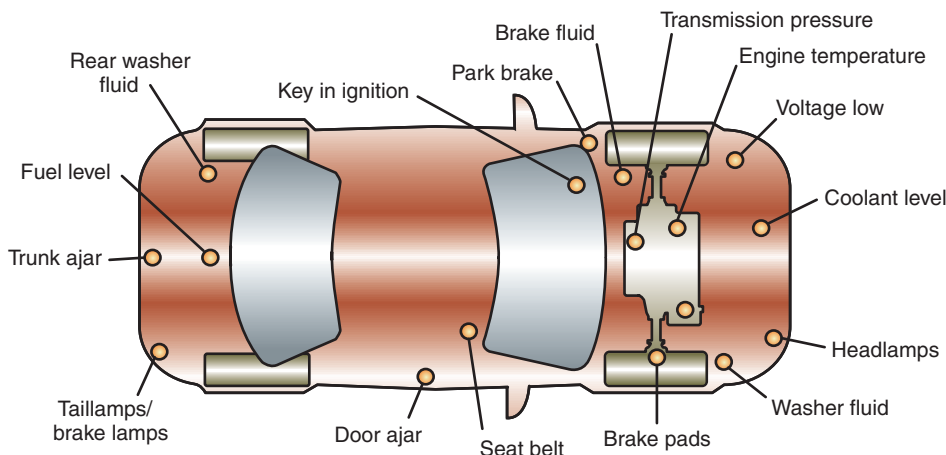
Computer-driven instrument cluster warning lamps are diagnosed using a scan tool. If the customer states that the lamp does not operate, the scan tool can be used to command activation of the lamp. If the lamp does not come on when commanded, the problem is a faulty lamp, circuit board, or instrument cluster module. If the lamp does light when commanded, the fault is in the signal to the instrument cluster.

If the customer states that the lamp is on all of the time, this indicates a problem in the monitored system. Use the scan tool to check for DTC and use the service information to diagnose the fault. If there are no problems in the monitored circuit, then you will need to diagnose the module that receives the lamp's sensor input. If there is no problem found in this module, the instrument cluster module will need to be diagnosed. Follow the service information procedures for all diagnostic tests.

## TRIP COMPUTERS

Simple trip computers use inputs from the speed sensor and the fuel gauge to perform their functions. Like most electronic instrument clusters, trip computers will usually have a self-diagnostic test procedure. Follow the manufacturer's procedure for initiating this test. If the trip computer passes the self-test, check the fuel gauge and speed sensor inputs.

Complex trip computers may receive inputs from several different areas of the vehicle (Figure 13-24). These systems will require the use of specific manufacturer diagnostic charts, specifications, and procedures. Using the skills you have acquired, you should be able to perform these tests competently.



**FIGURE 13-24** Complex information centers use many inputs to monitor the vehicle's subsystems.

**Classroom Manual**

Chapter 13, page 355

**Classroom Manual**

Chapter 13, page 350

Trip computer systems may have several different names. The most common are: Traveler, Vehicle Information Center, and Drive Information Centers.

**Classroom Manual**

Chapter 13, page 353



## TERMS TO KNOW

Bimetallic gauges  
Eddy currents  
Electromagnetic gauges  
Gauge  
Odometer  
Piezoresistive sensor  
Prove-out circuit  
Quartz swing needle  
Resistive shorts  
Tachometer  
Thermistor

## CASE STUDY

A customer brings his vehicle into the shop because the fuel level gauge does not operate. It remains on empty all of the time, regardless of how full the tank is. The technician checks the fuse box for any blown fuses and finds that all are good. He disconnects the lead wire to the fuel tank sending unit and probes for voltage. The test light comes on when he places the ignition switch in the ON position. When the sending unit lead is connected to ground through a 10-ohm resistor, the gauge needle moves to the FULL position.

Upon checking with the service information, the technician determines that this is normal operation. Before draining and removing the fuel tank, he uses a jumper wire to jump from the ground terminal of the sending unit to a known good ground on the frame. When he reconnects the lead wire and places the ignition switch in the RUN position, the gauge works properly. The technician cleans the ground connections for the sending unit and returns the vehicle to the customer.

## ASE-STYLE REVIEW QUESTIONS

- In a conventional instrument cluster, all of the gauges are inoperable. What is the LEAST likely cause of this?  
A. Faulty IVR.      C. Shorted sending unit.  
B. Blown fuse.      D. Faulty printed circuit.
- All of the following statements concerning gauge sending units are true EXCEPT:  
A. A gauge can use a switch as a sensor.  
B. A gauge can use a thermistor as a sensor.  
C. A gauge can use a piezoresistive sensor.  
D. A gauge can use a variable resistor as a sensor.
- The oil pressure warning light will not turn off with the engine running. A shop gauge confirms good oil pressure. What is the most likely cause?  
A. Faulty IVR.  
B. Damaged printed circuit board.  
C. Open in the wire to the oil pressure switch.  
D. Short to ground in the wire to the oil pressure switch.
- When testing the IVR-regulated voltage, the indicated reading was 2.5 volts over specifications.  
*Technician A* says that the IVR ground connection may be faulty.  
*Technician B* says that the alternator output may be too high.  
Who is correct?  
A. A only      C. Both A and B  
B. B only      D. Neither A nor B
- Technician A* says to use a voltmeter to test a thermistor sensor unit.  
*Technician B* says that the thermistor sensor measures pressure.  
Who is correct?  
A. A only      C. Both A and B  
B. B only      D. Neither A nor B
- Technician A* says when the ignition switch is in the START position the proving circuit should light the warning lamps.  
*Technician B* says if the sender switch lead is grounded, and the ignition switch is in the RUN position, the warning lamp should come on.  
Who is correct?  
A. A only      C. Both A and B  
B. B only      D. Neither A nor B
- A digital speedometer constantly reads 0 mph.  
*Technician A* says the speed sensor may be faulty.  
*Technician B* says the throttle position sensor may have an open.  
Who is correct?  
A. A only      C. Both A and B  
B. B only      D. Neither A nor B
- All gauges read low in a computer-controlled instrument cluster.  
*Technician A* says the connector to the cluster may be loose.  
*Technician B* says the cluster module may be at fault.  
Who is correct?  
A. A only      C. Both A and B  
B. B only      D. Neither A nor B



9. An electronically controlled instrument cluster is being diagnosed for no speedometer operation. Which of the following statements is most correct?
- If the BCM and/or cluster module passes its self-test, the fault is probably in the vehicle speed sensor circuit.
  - If the speedometer does not work but the odometer does, then the problem is probably in the vehicle speed sensor circuit.
  - If the speedometer fails to move during the self-test, the problem is probably in the vehicle speed sensor circuit.
  - All of the above.
10. Ford diagnostic mode displays are being discussed. *Technician A* says a CO displayed in the fuel gauge window indicates that the fuel level is near empty. *Technician B* says a CS indicates an open in the sender circuit.
- Who is correct?
- A only
  - B only
  - Both A and B
  - Neither A nor B

## ASE CHALLENGE QUESTIONS

1. The odometer of a vehicle equipped with a cable-driven speedometer is inoperative; however, the speedometer is working correctly.
- Technician A* says that the speedometer cable may be faulty.
- Technician B* says that the speedometer drive gear at the transmission may be stripped.
- Who is correct?
- A only
  - B only
  - Both A and B
  - Neither A nor B
2. The fuel gauge of a multiple bimetallic-type gauge instrument cluster is reading higher than normal.
- Technician A* says that the wire leading to the gauge sender unit may be open.
- Technician B* says that the resistance of the sender unit may be lower than normal.
- Who is correct?
- A only
  - B only
  - Both A and B
  - Neither A nor B
3. The water temperature warning light of a vehicle is on whenever the ignition key is in the ON position; when the engine is started, the light remains illuminated.
- Technician A* says that the sending unit wire may be shorted to ground.
- Technician B* says that the water temperature switch may be electrically open.
- Who is correct?
- A only
  - B only
  - Both A and B
  - Neither A nor B
4. The diagnosis of a digital instrument cluster that is missing two segments in its display is being discussed.
- Technician A* says that the cluster has excessive ground circuit resistance.
- Technician B* says that the cluster should be replaced.
- Who is correct?
- A only
  - B only
  - Both A and B
  - Neither A nor B
5. A vehicle equipped with an electronic instrument cluster has a “service engine” lamp illuminated; a speed sensor code (indicating the computer does not “see” vehicle speed) has been generated by the computer. The speedometer is working correctly; however, a scan tool that is connected to the vehicle’s on board computer indicates 0 mph whenever the vehicle is in motion.
- Technician A* says that the vehicle speed sensor may be faulty.
- Technician B* says that the on board computer may be faulty.
- Who is correct?
- A only
  - B only
  - Both A and B
  - Neither A nor B

*This page intentionally left blank*

Name \_\_\_\_\_ Date \_\_\_\_\_

## CHECKING A FUEL GAUGE

Upon completion of this job sheet, you should be able to diagnose an inaccurate or inoperative fuel gauge.

### ASE Correlation

This job sheet is related to the ASE Electrical/Electronic System Certification Exam's content area: *Gauges, Warning Devices, and Drive Information Systems Diagnosis and Repair*; task: Inspect, test, and replace gauges and gauge sending units, connectors, wires, and printed circuit boards of gauge circuits.

### Tools and Materials

- |                                            |                         |
|--------------------------------------------|-------------------------|
| A vehicle                                  | A DMM                   |
| Service information for the chosen vehicle | Miscellaneous resistors |
| Wiring diagram for the chosen vehicle      | A vehicle hoist         |

### Describe the vehicle being worked on:

Year \_\_\_\_\_ Make \_\_\_\_\_ Model \_\_\_\_\_  
 VIN \_\_\_\_\_ Engine type and size \_\_\_\_\_

### Procedure

Task Completed

- From the procedures listed in the service information, describe the procedures for testing the fuel gauge and fuel gauge sending unit on this vehicle.

---

---

---

---

---

---

---

---

- Locate the fuel gauge circuit wiring diagram and print out the schematic map the circuit from power to ground. Attach the print out to this job sheet.

- Follow the procedure to simulate a full fuel tank. Describe what happened when you followed this procedure; include in your answer your conclusions from this test.

---

---

---

---

---

---

---

---

4. Follow the procedure to simulate an empty fuel tank. Describe what happened when you followed this procedure; include in your answer your conclusions from this test.

---

---

---

---

---

Instructor's Response \_\_\_\_\_

---

---

Name \_\_\_\_\_ Date \_\_\_\_\_

## TESTING AN OIL PRESSURE WARNING LIGHT CIRCUIT

Upon completion of this job sheet, you should be able to test the oil pressure warning circuit and determine needed repairs.

### ASE Correlation

This job sheet is related to the ASE Electrical/Electronic System Certification Exam's content area: *Gauges, Warning Devices, and Drive Information Systems Diagnosis and Repair*; task: Diagnose the cause of constant, intermittent, or no operation of warning light/drive information systems.

### Tools and Materials

Vehicle with conventional analog instrument cluster with oil pressure warning lamp.

### Describe the vehicle being worked on:

Year \_\_\_\_\_ Make \_\_\_\_\_ Model \_\_\_\_\_  
 VIN \_\_\_\_\_ Engine type and size \_\_\_\_\_

### Procedure

1. Describe the normal conditions in which the oil pressure warning lamp should be on.

\_\_\_\_\_ Task Completed

\_\_\_\_\_  
 \_\_\_\_\_  
 \_\_\_\_\_

2. At what pressure should the oil pressure warning lamp turn off?
3. Referring to the service information and wiring diagrams, is the oil pressure warning lamp sending unit a normally open or normally closed switch?

\_\_\_\_\_

4. Locate the oil pressure warning lamp circuit and print it out. Map the circuit from power to ground, identifying components of the circuit. Attach printed copy to this job sheet.

5. List all possible causes for an oil pressure warning lamp that does not turn on.

\_\_\_\_\_  
 \_\_\_\_\_  
 \_\_\_\_\_  
 \_\_\_\_\_  
 \_\_\_\_\_

6. Unplug the sending unit connector and test for voltage with the ignition key in the RUN position with the engine off. Is voltage present? \_\_\_\_\_

7. If voltage is not present, what will your next step be? \_\_\_\_\_

---

---

8. If voltage was not present in step 6, test the circuit. What were your results and recommendations?

---

---

---

9. If voltage was present in step 6, describe the method to be used to test the sending unit.

---

---

---

---

10. Perform the test described in step 9 and record your results and recommendations.

---

---

---

---

Instructor's Response \_\_\_\_\_

---

---



Name \_\_\_\_\_ Date \_\_\_\_\_

## TESTING THE ELECTRONIC INSTRUMENT CLUSTER

Upon completion of this job sheet, you should be able to test the electronic instrument cluster using a scan tool or stand-alone diagnostic routines and determine needed repairs.

### ASE Correlation

This job sheet is related to the ASE Electrical/Electronic System Certification Exam's content area: *Gauges, Warning Devices, and Driver Information Systems Diagnosis and Repair*; tasks: Diagnose the cause(s) of intermittent, high, low, or no readings on electronic digital instrument clusters.

### Tools and Materials

- A vehicle equipped with electronic instrument cluster
- Scan tool
- Service information

### Describe the vehicle being worked on:

Year \_\_\_\_\_ Make \_\_\_\_\_ Model \_\_\_\_\_  
 VIN \_\_\_\_\_ Engine type and size \_\_\_\_\_

### Procedure

\_\_\_\_\_ Task Completed

1. Test the operation of the gauges. Describe the symptoms.

\_\_\_\_\_  
 \_\_\_\_\_

2. Are there any other related symptoms?  Yes  No  
 If yes, describe the symptom:

\_\_\_\_\_  
 \_\_\_\_\_

3. Refer to the proper service information to determine if a self-diagnostic routine can be performed. If so, describe how to enter the diagnostics.

\_\_\_\_\_  
 \_\_\_\_\_  
 \_\_\_\_\_  
 \_\_\_\_\_

4. Is the self-diagnostic routine capable of displaying fault codes?  Yes  No

5. Perform the procedure listed in step 3 and record the results and any DTCs.

\_\_\_\_\_  
 \_\_\_\_\_

6. Use a scan tool and access the electronic instrument cluster. Does the scan tool indicate that DTCs are present?  Yes  No

If YES, record the DTCs:

---



---

7. Based on the tests so far, is the fault in the instrument cluster or in the sensor circuits?  
 CLUSTER  SENSOR

8. Based on the results so far, what tests need to be performed to find the cause of the fault?

---



---

9. Perform the tests listed in step 8. What is your determination and recommendation?

---



---

Instructor's Response \_\_\_\_\_

---



---

<b>DIAGNOSTIC CHART 13-1</b>	
PROBLEM AREA:	Instrument cluster gauges
SYMPTOMS:	One or all gauges fluctuate from low or high to normal readings.
POSSIBLE CAUSES:	1. Poor ground connection. 2. Excessive resistance. 3. Poor connections. 4. Faulty sending unit. 5. Defective printed circuit.

<b>DIAGNOSTIC CHART 13-2</b>	
PROBLEM AREA:	Instrument cluster gauges
SYMPTOMS:	One or all gauges read high.
POSSIBLE CAUSES:	1. Faulty instrument voltage regulator. 2. Shorted printed circuit. 3. Faulty sending unit. 4. Short to ground in sending unit circuit. 5. Faulty gauge. 6. Poor sending unit ground connection.

<b>DIAGNOSTIC CHART 13-3</b>	
PROBLEM AREA:	Instrument cluster gauges
SYMPTOMS:	One or all gauges read low.
POSSIBLE CAUSES:	<ol style="list-style-type: none"> <li>1. Faulty instrument voltage regulator.</li> <li>2. Poor sending unit ground connection.</li> <li>3. Improper bulb application.</li> <li>4. Improper connections.</li> <li>5. Faulty back-up switch contacts.</li> </ol>

<b>DIAGNOSTIC CHART 13-4</b>	
PROBLEM AREA:	Instrument cluster gauges
SYMPTOMS:	One or all gauges fail to read.
POSSIBLE CAUSES:	<ol style="list-style-type: none"> <li>1. Blown fuse.</li> <li>2. Open in the printed circuit.</li> <li>3. Faulty gauge.</li> <li>4. Poor common ground connection.</li> <li>5. Open in the sending unit circuit.</li> <li>6. Faulty sending unit.</li> <li>7. Faulty instrument voltage regulator.</li> <li>8. Poor electrical connection to cluster.</li> <li>9. Shorted sending unit circuit.</li> </ol>

<b>DIAGNOSTIC CHART 13-5</b>	
PROBLEM AREA:	Warning light operation
SYMPTOMS:	Warning light remains on all of the time.
POSSIBLE CAUSES:	<ol style="list-style-type: none"> <li>1. Sending unit circuit grounded.</li> <li>2. Faulty sending unit switch.</li> </ol>

<b>DIAGNOSTIC CHART 13-6</b>	
PROBLEM AREA:	Warning light operation
SYMPTOMS:	Warning light fails to operate on an intermittent basis.
POSSIBLE CAUSES:	<ol style="list-style-type: none"> <li>1. Loose sending unit circuit connections.</li> <li>2. Faulty sending unit.</li> </ol>

<b>DIAGNOSTIC CHART 13-7</b>	
PROBLEM AREA:	Warning light operation
SYMPTOMS:	One or all warning lights fail to operate.
POSSIBLE CAUSES:	<ol style="list-style-type: none"> <li>1. Blown fuse.</li> <li>2. Burned-out bulb.</li> <li>3. Open in the circuit.</li> <li>4. Defective sending unit switches.</li> </ol>

<b>DIAGNOSTIC CHART 13-8</b>	
PROBLEM AREA:	Electronic instrument panel
SYMPTOMS:	Digital display does not light.
POSSIBLE CAUSES:	<ol style="list-style-type: none"> <li>1. Blown fuse.</li> <li>2. Inoperative power and ground circuit.</li> <li>3. Faulty instrument panel.</li> </ol>

<b>DIAGNOSTIC CHART 13-9</b>	
PROBLEM AREA:	Electronic instrument panel
SYMPTOMS:	Speedometer reads wrong speed.
POSSIBLE CAUSES:	<ol style="list-style-type: none"> <li>1. Faulty speedometer.</li> <li>2. Wrong gear on vehicle speed sensor (VSS).</li> <li>3. Wrong tire size.</li> </ol>

<b>DIAGNOSTIC CHART 13-10</b>	
PROBLEM AREA:	Electronic instrument panel
SYMPTOMS:	Fuel gauge displays top and bottom two bars.
POSSIBLE CAUSES:	<ol style="list-style-type: none"> <li>1. Open or short in circuit.</li> </ol>

<b>DIAGNOSTIC CHART 13-11</b>	
PROBLEM AREA:	Electronic instrument panel
SYMPTOMS:	Fuel computer displays CS or CO.
POSSIBLE CAUSES:	<ol style="list-style-type: none"> <li>1. Open or short in fuel gauge sender.</li> <li>2. Inoperative instrument panel.</li> </ol>

<b>DIAGNOSTIC CHART 13-12</b>	
PROBLEM AREA:	Electronic instrument panel
SYMPTOMS:	Odometer displays error.
POSSIBLE CAUSES:	<ol style="list-style-type: none"> <li>1. Inoperative odometer memory module in instrument panel.</li> </ol>

<b>DIAGNOSTIC CHART 13-13</b>	
PROBLEM AREA:	Electronic instrument panel
SYMPTOMS:	Fuel gauge display is erratic.
POSSIBLE CAUSES:	<ol style="list-style-type: none"> <li>1. Sticky or inoperative fuel gauge sender.</li> <li>2. Fault in circuit.</li> <li>3. Inoperative fuel gauge.</li> </ol>

<b>DIAGNOSTIC CHART 13-14</b>	
PROBLEM AREA:	Electronic instrument panel
SYMPTOMS:	Fuel gauge will not display FULL or EMPTY.
POSSIBLE CAUSES:	1. Sticky or inoperative fuel gauge sender.

<b>DIAGNOSTIC CHART 13-15</b>	
PROBLEM AREA:	Electronic instrument panel
SYMPTOMS:	Fuel economy function of message center is erratic or inoperative.
POSSIBLE CAUSES:	1. Inoperative fuel flow signal. 2. Faulty wiring. 3. Inoperative instrument panel.

<b>DIAGNOSTIC CHART 13-16</b>	
PROBLEM AREA:	Electronic instrument panel
SYMPTOMS:	Extra or missing display segments.
POSSIBLE CAUSES:	1. Inoperative instrument panel.

<b>DIAGNOSTIC CHART 13-17</b>	
PROBLEM AREA:	Electronic instrument panel
SYMPTOMS:	Speedometer always reads zero.
POSSIBLE CAUSES:	1. Faulty wiring. 2. Inoperative instrument panel.

<b>DIAGNOSTIC CHART 13-18</b>	
PROBLEM AREA:	Electronic instrument panel
SYMPTOMS:	Temperature gauge displays top and bottom two bars.
POSSIBLE CAUSES:	1. Short in circuit. 2. Inoperative coolant temperature sender. 3. Inoperative instrument panel.

*This page intentionally left blank*



## ELECTRICAL ACCESSORIES DIAGNOSIS AND REPAIR



### UPON COMPLETION AND REVIEW OF THIS CHAPTER, YOU SHOULD BE ABLE TO:

- Identify the causes of no operation, intermittent operation, or constant horn operation.
- Diagnose the cause of poor sound quality from the horn system.
- Perform diagnosis and repair of no windshield wiper operation in one speed only or in all speeds.
- Identify causes for slower-than-normal wiper operation.
- Determine the cause for improper park operation.
- Identify causes for continuous wiper operation.
- Diagnose faulty intermittent wiper system operation.
- Remove and install wiper motors and wiper switches.
- Diagnose computer-controlled wiper systems.
- Determine the causes for improper operation of the windshield washer system and be able to replace the pump if required.
- Perform diagnosis of problems associated with blower motor circuits.
- Diagnose and repair electric rear window defoggers.
- Diagnose the power window system.
- Diagnose common problems associated with the power seat system.
- Diagnose the memory seat function.
- Perform diagnosis of the power door lock and automatic door lock systems.
- Diagnose keyless entry systems.
- Diagnose vehicle alarm systems.
- Perform tests on the antitheft controller to determine proper operation.
- Use self-diagnostic tests on alarm systems that provide this feature.
- Diagnose the immobilizer system.
- Perform self-diagnostic procedures on electronic cruise control systems.
- Diagnose causes for no, intermittent, and erratic cruise control operation.
- Test the cruise control servo assembly for proper operation.
- Replace the servo assembly and adjust actuator cable.
- Replace the cruise control switch assembly.
- Determine the circuit fault causing a malfunction in sunroof operation.
- Determine the causes of heated windshield malfunctions.
- Diagnose vehicle audio and video entertainment systems.

### INTRODUCTION

The electrical accessories included in this chapter represent the most often performed electrical repairs. Most of the systems discussed do not provide for rebuilding of components. The technician must be capable of diagnosing the fault and then replacing the defective part. As with any electrical system, always use a systematic diagnostic approach to finding the cause. Refer to the service manual to obtain information concerning correct system operation. The fault is easier to locate once you understand how the system is supposed to operate.

Included in this chapter are diagnostic and repair procedures for horn systems, windshield wipers and washer systems, blower motors, electric defogger systems, power seat and window systems, and power door locks.

Also, you will learn how to service electronic accessories designed to increase passenger comfort, provide ease of operation, and increase passenger safety. These systems include electronic cruise control, memory seats, sunroof, automatic door locks, keyless entry, heated windshields, antitheft systems, and vehicle radio/stereo audio systems.

Most of these systems are additions to existing systems. For example, the memory seat feature is an addition to the conventional power seat system. As vehicles and accessories become more sophisticated, these “luxury” features will become more commonplace. Today’s technician is expected to accurately and quickly diagnose malfunctions in these systems.

Although the procedures presented here are typical, always refer to the proper service information for the vehicle you are servicing.

### Classroom Manual

Chapter 14, page 359



### SPECIAL TOOLS

Jumper wires  
Voltmeter  
Test light  
Ohmmeter  
Fender covers

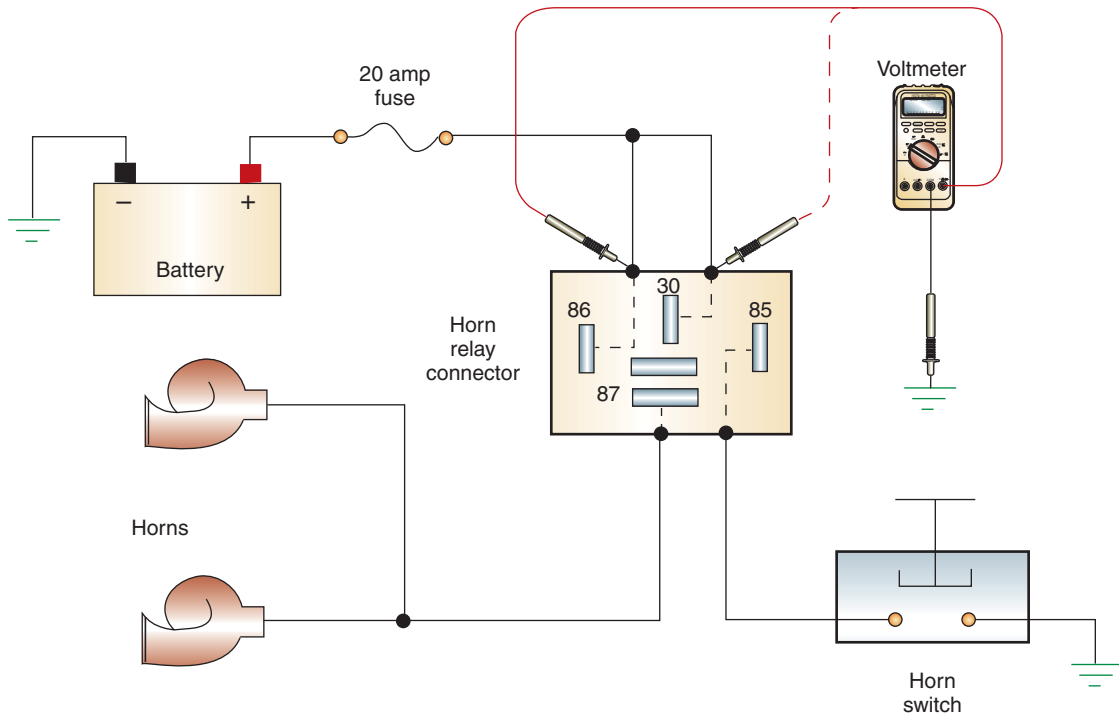
## HORN DIAGNOSIS

Customer complaints associated with the horn system can include no operation, intermittent operation, continuous operation, or poor sound quality. Testing of the horn system varies between systems that do and do not use a relay.

### No Horn Operation

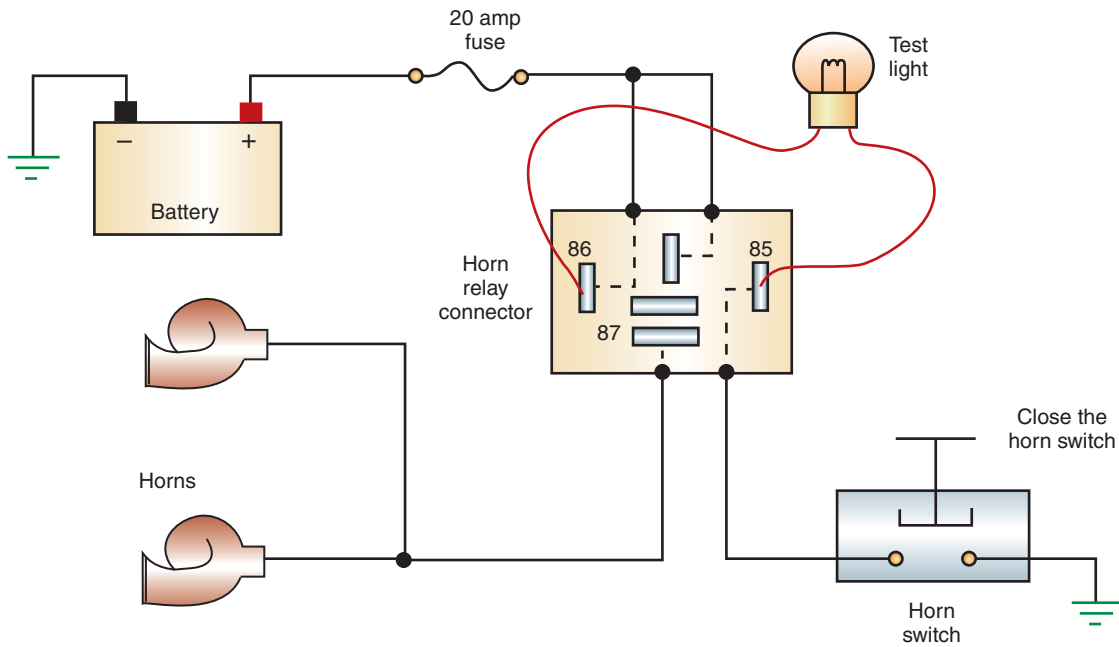
**Systems with Relay.** When a customer complains of no horn operation, first confirm the complaint by depressing the horn button. If it is mounted in the steering wheel, rotate the steering wheel from stop to stop while depressing the horn button. If the horn sounds intermittently while the steering wheel is turned, the problem is probably in the sliding contact ring in the steering column, or the tension spring is worn or broken. Also, a faulty clock spring may cause intermittent horn operation as the steering wheel is turned. Check the air bag system for any DTCS associated with the clock spring circuit. If the horn does not sound during this test, continue to check the system as follows:

1. Check the fuse or fusible link. If defective, replace as needed. After replacement of the fuse, operate all other circuits it protects. It is possible that another circuit is faulty but the customer has not noticed.
2. Connect a fused jumper wire from the battery positive terminal to the horn terminal. If the horn sounds, continue testing; if the horn does not sound, check the ground connection. Replace the horn if the ground is good.
3. Remove the relay from its connector and check for voltage at terminals 30 and 86 (Figure 14-1). If there is no voltage at these points, trace the wiring from the relay to the battery to locate the problem. Continue testing if voltage is present at the power feed terminals.
4. With the relay removed, connect a test light across terminals 85 and 86 of the relay connector (Figure 14-2). Press the horn switch and observe the test light. The test light should illuminate. If it does not, the horn switch or its circuit is faulty—go to step 7. If the light illuminates, continue testing.
5. Use a fused jumper wire and jump terminals 30 and 87 (Figure 14-3). If the horns sound, replace the relay. If the horns do not sound, continue to test.
6. In a multiple-horn system, test for voltage at the last common connection between the horn relay and the horns (Figure 14-4). On a single-horn system, test for voltage at the horn terminal. Voltage should be present at this connection only when the horn button is depressed. If there is no voltage at this connection, repair the open between the relay and the common connection. If voltage is present, check the individual circuits from the connection to the horns; repair as needed.



**FIGURE 14-1** Testing for voltage to the relay connector.

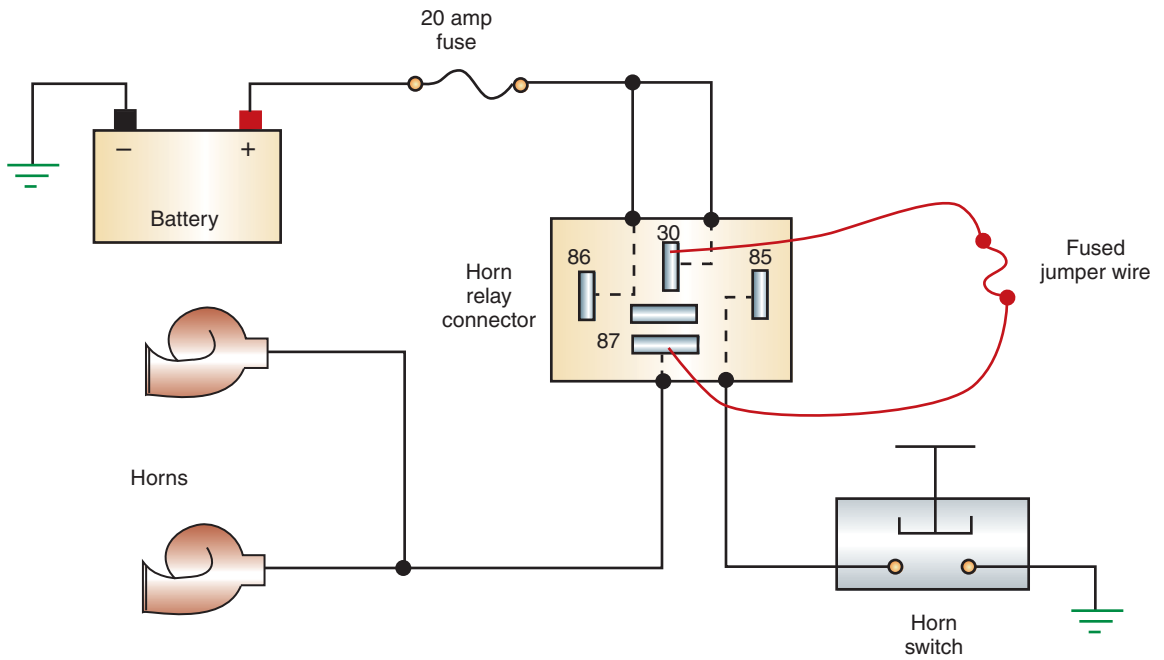
© Delmar/Cengage Learning



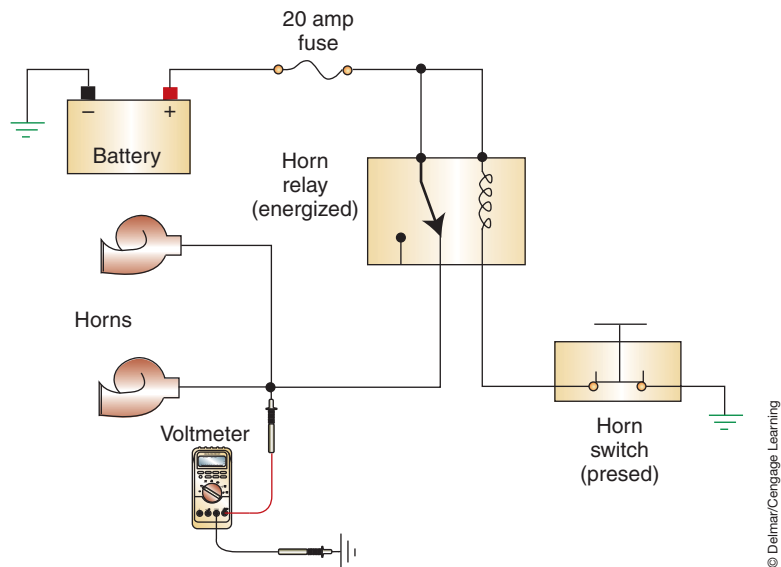
**FIGURE 14-2** Using a test light to test the horn switch circuit.

© Delmar/Cengage Learning

7. Check for voltage on the battery side of the horn switch. If there is no voltage at this location, the fault is between the relay and the switch. Continue testing if voltage is present.
8. Check for continuity through the switch. If good, check the ground connection for the switch. Then recheck operation. Replace the horn switch if there is no continuity when the button is depressed.



**FIGURE 14-3** Using a fused jumper wire to test the horn circuit. If the horn sounds, the relay is faulty.



**FIGURE 14-4** Testing for voltage at the last common connection.

**Systems without Relay.** Follow the steps described under “Systems with Relay” to confirm the complaint. If this step confirms that the horn is not operational, perform the following tests to locate the fault:

1. Check the fuse or fusible link. If defective, replace as needed. After replacing the fuse, operate all other circuits it protects. It is possible that another circuit is faulty but the customer has not noticed.
2. Connect a jumper wire from the battery positive terminal to the horn terminal. If the horn sounds, continue testing; if the horn does not sound, check the ground connection. Replace the horn if the ground is good.

3. In a multiple-horn system, test for voltage at the last common connection between the horn switch and the horns. On a single-horn system, test for voltage at the horn terminal. Voltage should be present at this connection only when the horn button is depressed. Continue testing if there is no voltage at this connection. If voltage is present, check the individual circuits from the connection to the horns; repair as needed.
4. Check for voltage at the horn side of the switch when the button is depressed. If voltage is present, the problem is in the circuit from the switch to the horn(s). Continue testing if there is no voltage at this connection.
5. Check for voltage at the battery side of the switch. If voltage is present, the switch is faulty and must be replaced. If there is no voltage at this terminal, the problem is in the circuit from the battery to the switch.

## Poor Sound Quality

Poor sound quality can be the result of several factors. In a multiple-horn system, if one of the horns is not operating, the horn sound quality may suffer. Other reasons include a damaged diaphragm, excessive circuit resistance, poor ground connections, or improperly adjusted horns.

If one horn of a multiple-horn system is not operating, use a jumper wire from the battery positive terminal to the horn terminal to determine whether the fault is in the horn or in the circuit. If the horn sounds, the problem is in the circuit between the last common connection and the affected horn.

If one or all horns are producing poor quality sound, use a voltmeter to measure the voltage at the horn terminal when the horn switch is closed. The voltage should be within 0.5 volt of battery voltage. If the voltage measured is less than battery voltage, there is excessive voltage drop in the circuit. Work back through the circuit measuring voltage drop across connectors, relays, and switches to find the source of the high resistance.

If the voltage to the horn is of the proper value, test the ground circuit. Use the voltage drop method while the horn switch is closed. If the voltage drop is excessive, check the connections to ground.

If the circuits test is good, connect a jumper wire between the battery positive terminal and the horn terminal to activate the horn. With the horn sounding, turn the adjusting screw counterclockwise one quarter to three eighths of a turn. Replace the horn if the sound quality cannot be improved.

## Horn Sounds Continuously

A horn that sounds continuously is usually caused by a sticking horn switch or sticking contact points in the relay. To find the fault, disconnect the horn relay from the circuit. Use an ohmmeter to check for continuity from the battery feed terminal of the relay to the horn circuit terminal (Figure 14-5). If there is continuity, the relay is defective. If there is no continuity through the relay, test the switch.

The easiest way to test the switch circuit is to measure for continuity between the relay connector terminal 85 and ground. With the horn switch released, there should not be continuity to ground. If there is continuity, then the circuit to the horn switch is shorted to ground or the switch contacts are stuck. Use an ohmmeter to test the switch in the normal manner.

Systems that control the horn function by computers will have the microprocessor control the relay coil ground circuit or use high-side drivers to operate the horns. Often a scan tool can be used to actuate the horns. If the system works properly with the scan tool, the problem is in the inputs to the computer. If the system does not operate when actuated with the scan tool, the problem may be the driver circuits, faulty horn, faulty horn ground circuit, or defective module.

### Classroom Manual

Chapter 14, page 361



### SPECIAL TOOLS

Voltmeter  
Jumper wires  
Fender covers



### SPECIAL TOOLS

Ohmmeter  
Fender cover



### SERVICE TIP:

Most modules that use high-side drivers are capable of detecting an open circuit. Often, once a fault in the circuit is determined, the high-side driver is turned off for the remainder of that ignition cycle. If you disconnect the circuit from the module to the horn, the high-side driver may have been shut down and you will need to cycle the ignition switch between each test.

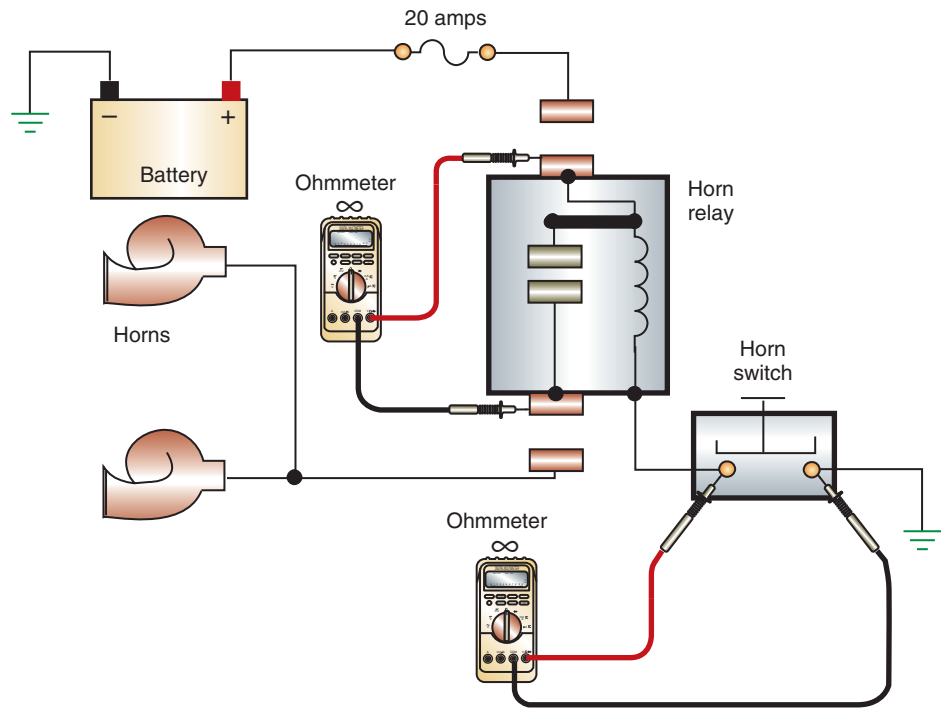


FIGURE 14-5 Ohmmeter tests to find cause of continuous horn operation.

### Classroom Manual

Chapter 14, page 363

## WIPER SYSTEM SERVICE

Customer complaints concerning windshield wiper operation can include no operation, intermittent operation, continuous operation, and wipers will not park. Other complaints have to do with blade adjustment (such as blades slapping the molding or one blade parks lower than the other).

When a customer brings the vehicle into the shop because of faulty windshield wiper operation, the technician needs to determine if it is an electrical or mechanical problem. To do this, disconnect the arms to the wiper blades from the motor (Figure 14-6). Turn on the wiper system. Observe operation of the motor. The problem is mechanical if the motor is operating properly.

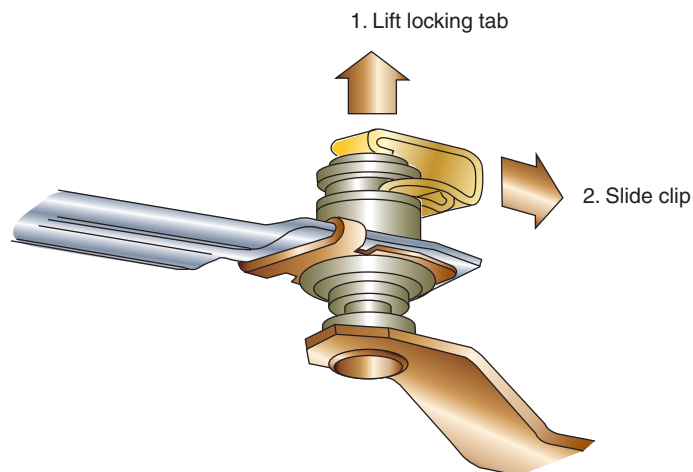


FIGURE 14-6 To remove the clip, lift up the locking tab and pull the clip.



## No Operation in One Speed Only

Problems that cause the system to not operate in only one switch position are usually electrical. Use the service manual's wiring schematic to determine proper operation. For example, use the three-speed wiper system schematic illustrated (Figure 14-7) to determine the cause of a motor that does not operate in the MEDIUM speed position only. The problem is that the 7-ohm resistor is open. The problem could not be the shunt field in the motor because LOW and HIGH speeds operate; nor could it be in the wiring to the motor because this is shared by all speeds.

An opened resistor can be verified by using a voltmeter to measure voltage at the terminal leading to the shunt field. If it drops to 0 volts in the MEDIUM position, the switch must be replaced. By proper use of the wiring schematic and by understanding the correct operation of the system, you are able to diagnose this problem without having to use any test equipment. The voltmeter is used only to verify your conclusions.

In two-speed systems, the motor operating in only one speed position can be caused by several different faults. It will require the use of wiring schematics and test equipment to locate. Use (Figure 14-8) to step through a common test sequence to locate the reason why the motor does not operate in the HIGH position.

Turn the ignition switch to the ACC position if the wipers will operate in this position. If not, place the ignition switch in the RUN position. Place the wiper switch in the HIGH position. Use a voltmeter to test for voltage at the high-speed connector of the motor. If voltage is present at this point, the high-speed brush is worn or the wire from the terminal to the brush is open. Most shops do not rebuild the wiper motor; replacement is usually the preferred service. If there is no voltage present at the high-speed connector, check for voltage at connector terminal H for the switch. If voltage is present at this point, the fault is in the circuit from the switch to the motor. If there is no voltage at this point, replace the switch.

To test for no LOW speed operation only, use the same procedure to test the low-speed circuit.



### SPECIAL TOOLS

Voltmeter  
Fender covers



### CAUTION:

Do not leave the ignition switch in the RUN position without the engine running for extended periods of time. This may result in damage to the ignition system components.

This instance is used as an example of troubleshooting the wiper system. Be sure to use the correct schematic for the vehicle you are working on.

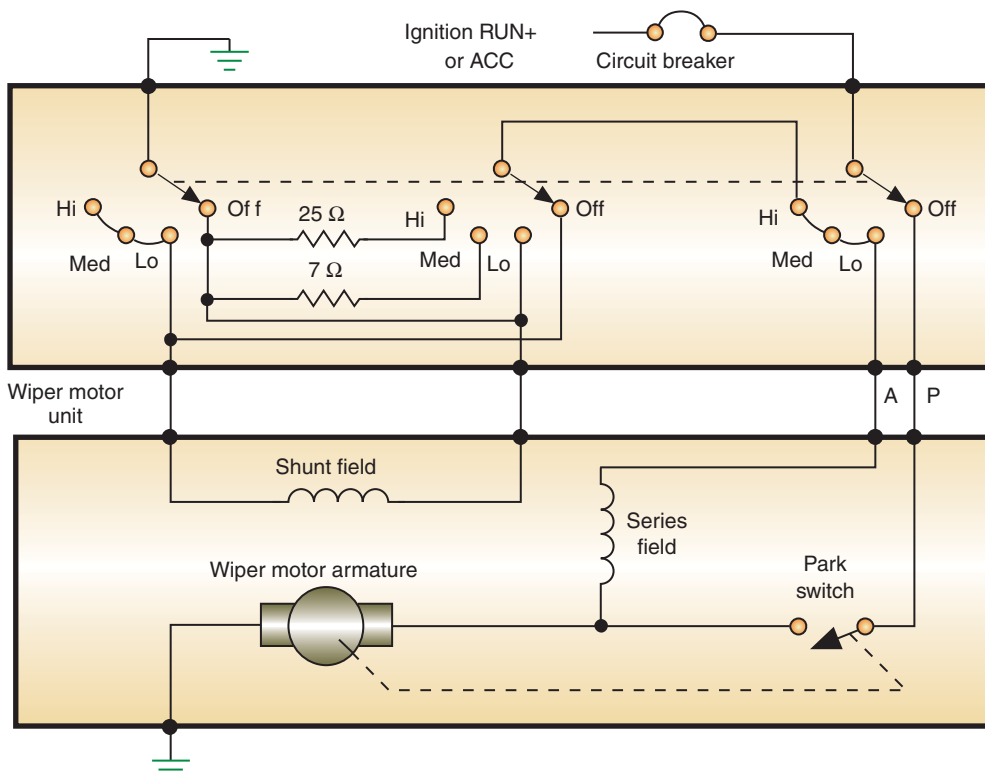
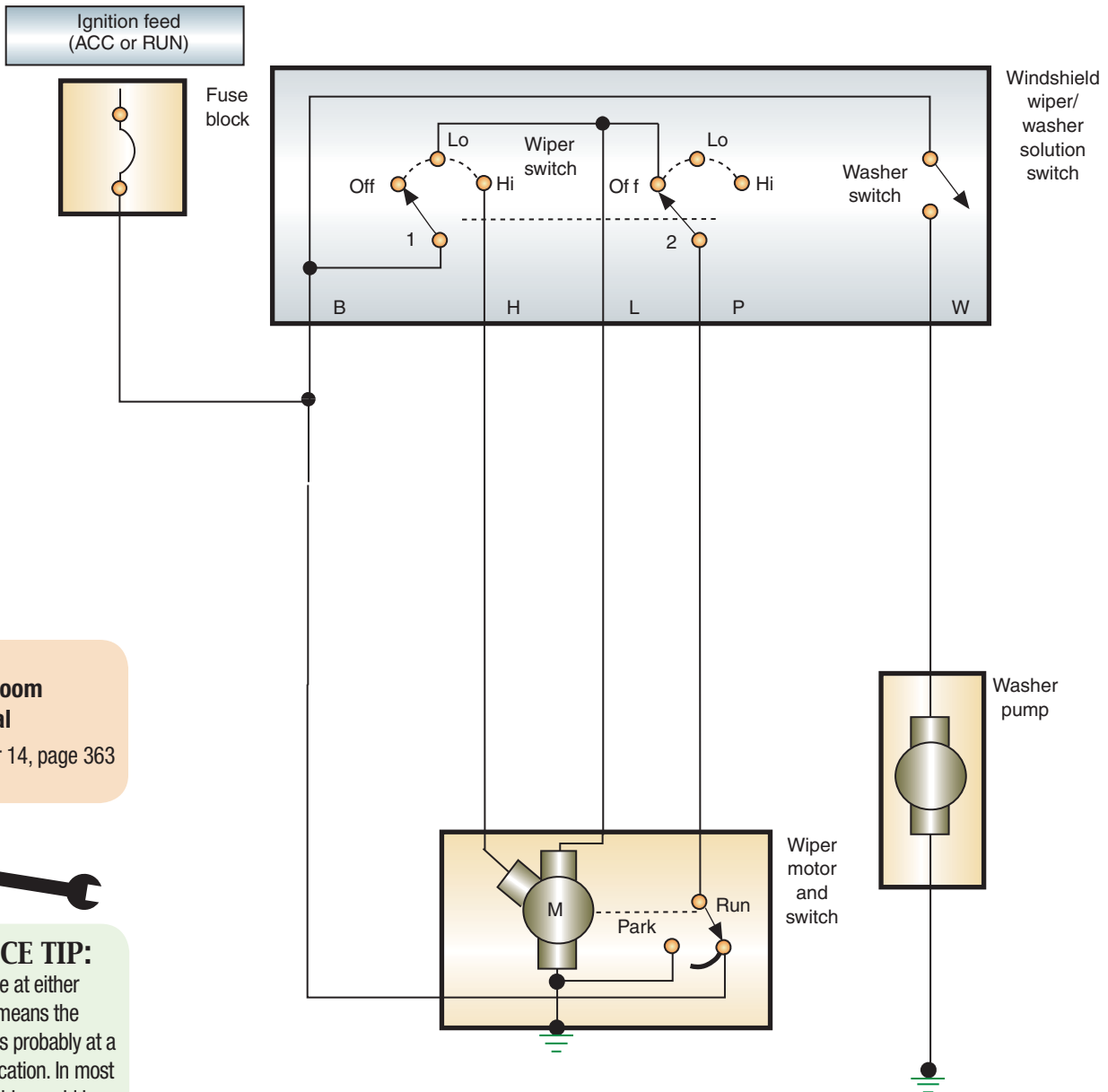


FIGURE 14-7 Three-speed wiper system schematic.

© Delmar/Cengage Learning



**Classroom Manual**  
Chapter 14, page 363



**SERVICE TIP:**

No voltage at either terminal means the problem is probably at a shared location. In most systems this would be the power supply portion of the wiper switch and the switch itself. If there is no voltage at either terminal, go directly to the power supply terminal of the switch. If the switch is good and power is through the switch, the problem is in the wiring loom. Check all connectors. If good, remove the harness protector and inspect the wires for burned insulation or breaks.

FIGURE 14-8 Two-speed wiper circuit.

**No Wiper Operation**

If the wiper motor does not operate in any speed position, check the fuse. If the fuse is blown, replace it and test the operation of the motor. Also check for binding in the mechanical portion of the system. This can cause an overload and blow the fuse.

If the fuse is good, check the motor ground by using a jumper wire from the motor body to a good chassis ground. If the motor operates when the ignition switch is in the RUN position and the wiper switch is placed in all speed positions, repair the ground connection. Continue testing if the motor does not operate.

Use a voltmeter to check for voltage at the low-speed terminal of the motor with the ignition switch in the RUN or ACC position and the wiper switch in LOW position. If there is no voltage at this point, test for voltage on the low-speed terminal of the wiper switch. If the voltmeter indicates battery voltage at this terminal, the fault is in the circuit between the switch and motor. Look for indications of burned insulation or other damage that would affect both the high- and low-speed circuit.

No voltage at the low-speed terminal of the wiper switch indicates the fault may be in the switch or the power feed circuit. Test for battery voltage at the battery supply terminal of the switch. If there is voltage at this point, the switch is faulty and needs to be replaced. If no voltage is at the supply terminal, trace the circuit back to the battery to locate the fault.

If battery voltage was present at the low-speed terminal of the motor, check for voltage at the high-speed terminal. Voltage at both of these terminals indicates the motor is faulty and needs to be replaced. If there is no voltage at the high-speed terminal, use the procedure just described to trace the high-speed circuit.

## Slower-than-Normal Wiper Speeds

Slower-than-normal wiper speeds can be caused by electrical or mechanical faults. An ammeter can be used to determine the current draw of the motor with and without the mechanical portion connected. If the draw changes substantially when the mechanical portion is removed, the fault is in the arms and/or wiper blades.

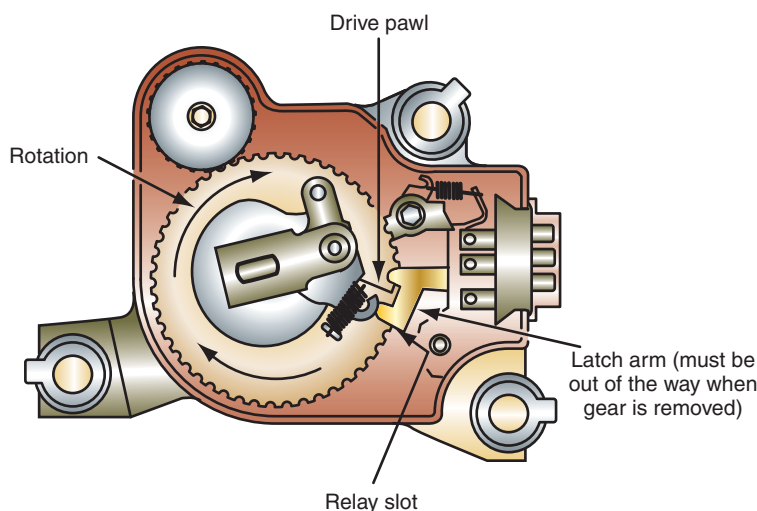
Most electrical circuit faults that result in slow wiper operation are caused by excessive resistance. If the complaint is that all speeds are slow, use the voltage drop test procedure to check for resistance in the power feed supply circuit to the wiper switch. If the power supply circuit is good, then check the switch for excessive resistance.

If the insulated side voltage tests fail to locate the problem, check the voltage drop on the ground side of the wiper motor. Connect the voltmeter positive lead to the ground terminal of the motor (or motor body) and the negative lead to the vehicle chassis. The voltage drop should be no more than 0.1 volt. If excessive, repair the ground circuit connections. If voltage drop on both the insulated and ground sides of the motor are within specifications, the fault is in the motor.

## Wipers Will Not Park

The most common complaint associated with a faulty park switch is that the wipers stop in the position they are in when the switch is turned off. This may not be the direct fault of the **park switch**, however. The park switch is located inside the motor assembly. It supplies current to the motor after the wiper control switch has been turned to the PARK position. This allows the motor to continue operating until the wipers have reached their park position.

The operation of the park switch can usually be observed by removing the motor cover (Figure 14-9). Operate the wipers through three or four cycles while observing the latch arm.



© Delmar/Cengage Learning

**FIGURE 14-9** Checking the operation of the park switch while the motor is operating.



### SPECIAL TOOLS

Digital voltmeter  
Fender covers

### Classroom Manual

Chapter 14, page 363



### SPECIAL TOOLS

Ammeter  
Voltmeter  
Fender covers

### Classroom Manual

Chapter 14, page 364



## SPECIAL TOOLS

Test light  
Voltmeter  
Fender covers

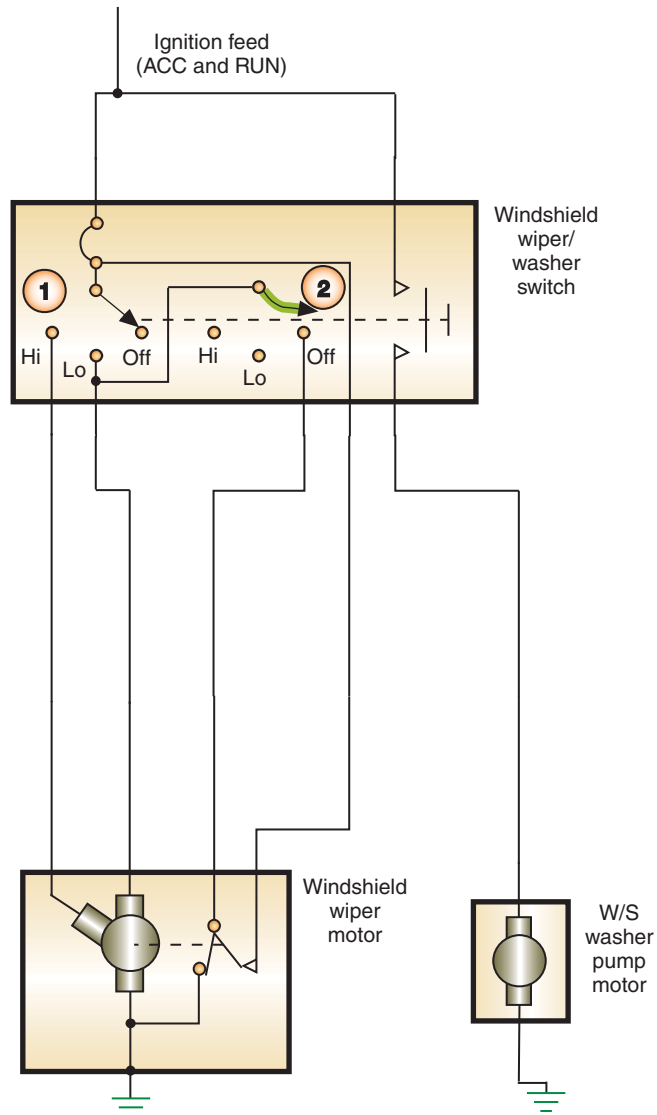
Some motors provide for replacement of the park switch. However, most shops replace the motor.

When the wiper switch is placed in the OFF position, the park switch latch must be in position to catch the drive pawl. Check to make sure the drive pawl is not bent. If good, replace the park switch.

A faulty wiper switch can also cause the park feature to not operate. Using the illustration (Figure 14-10), if wiper 2 is bent or broken so it does not make an electrical connection with the contacts, the wipers will not park even with the park switch in the PARK position, as shown. To test the switch, check for voltage at the low-speed circuit when the switch is moved from the LOW to the OFF position. If the switch is operating properly, there should be voltage present for a few seconds after the switch is in the OFF position. No voltage at this circuit when the wiper switch is turned off indicates that the problem may be in the switch.

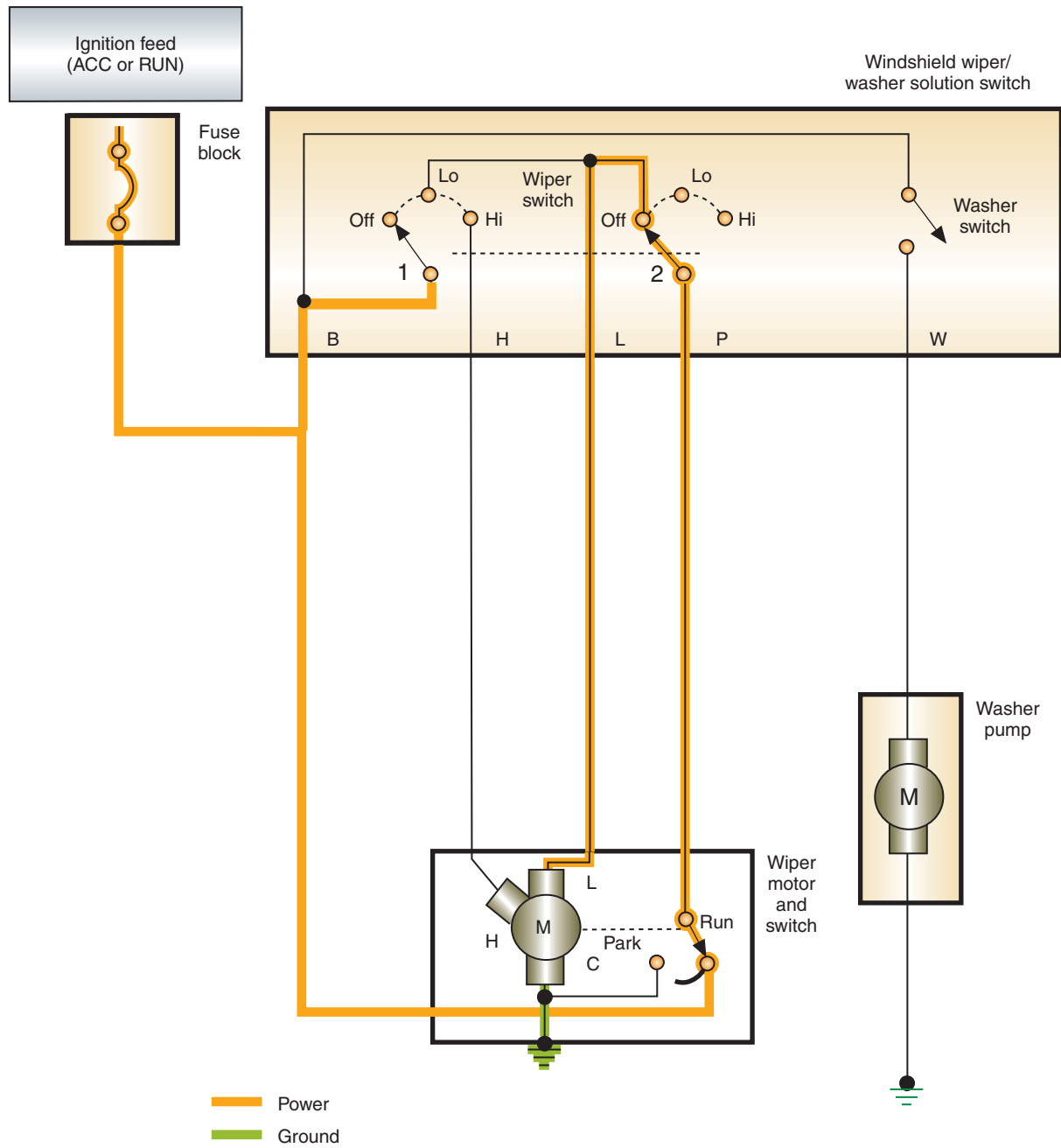
The park switch operation can also be checked by using a test light to probe for voltage on the park switch circuit when the wiper switch is turned off. Probing for voltage at this circuit should produce a pulsating light when the motor is running.

If the wiper blades continue to operate with the wiper switch in the OFF position, the most probable cause is “welded” contacts in the park switch (Figure 14-11). If the park



**FIGURE 14-10** A faulty contact wiper in the switch can cause the park feature to not operate.

© Delmar/Cengage Learning



**FIGURE 14-11** Sticking contacts in the park switch can cause the wipers to operate even after the switch is turned off.

switch does not open, current will continue to flow to the wiper motor. The only way to turn off the wipers is to turn off the ignition switch, physically remove the wires to the motor, or pull the fuse.

### Intermittent Wiper System Diagnosis

The illustration shown (Figure 14-12) is a schematic of the intermittent wiper system that Ford uses. If the intermittent function is the only portion of the system that fails to operate properly, begin by checking the ground connection for the timer module. If the ground is good, perform a continuity test of the switch using an ohmmeter (Figure 14-13). If the switch is good and all wires and connections are good, then replace the module.

**Classroom Manual**  
Chapter 14, pages 345, 374



**SPECIAL TOOLS**  
Ohmmeter  
Fender covers

© Delmar/Cengage Learning

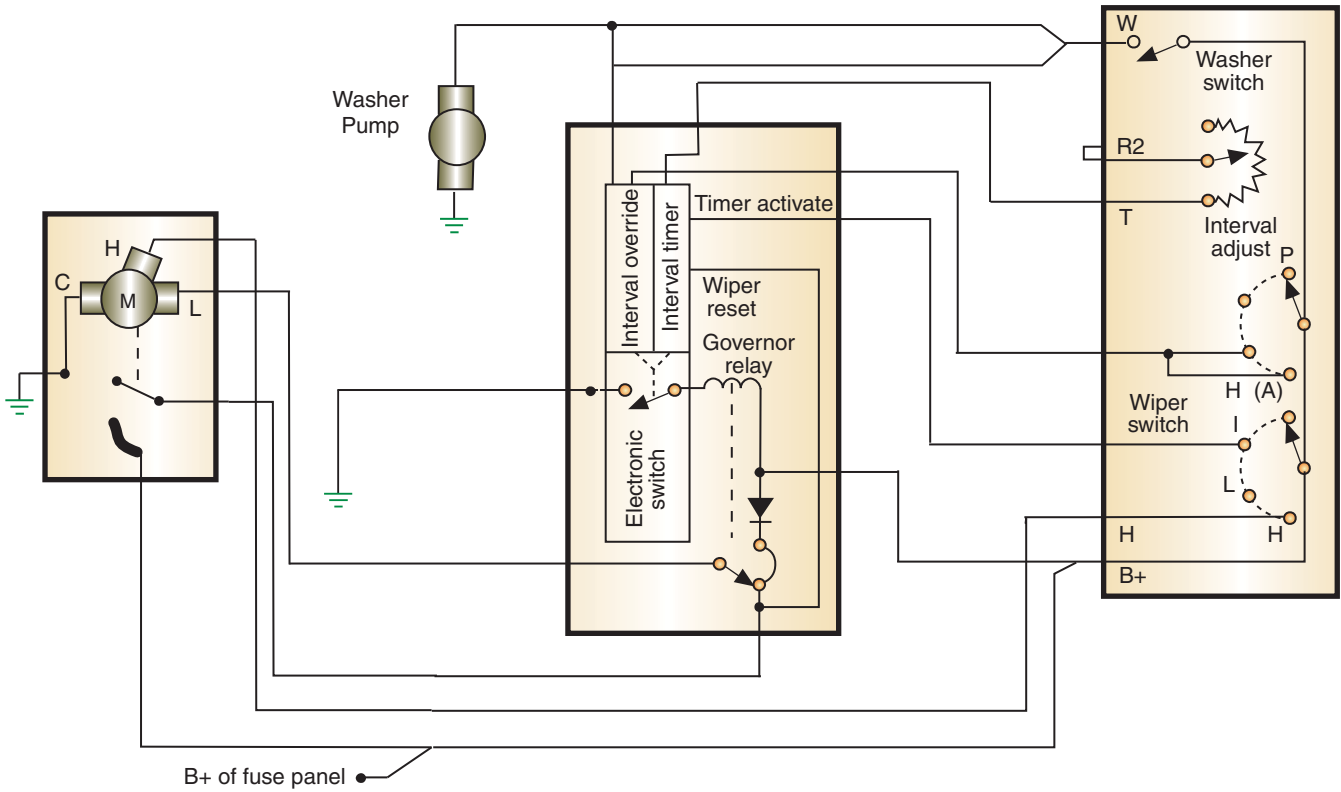
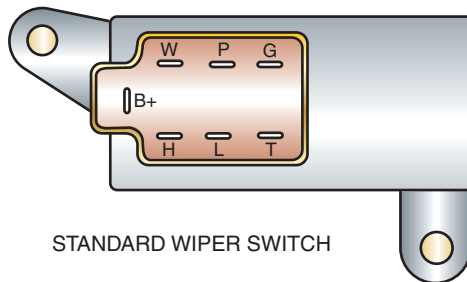


FIGURE 14-12 Intermittent wiper system schematic.



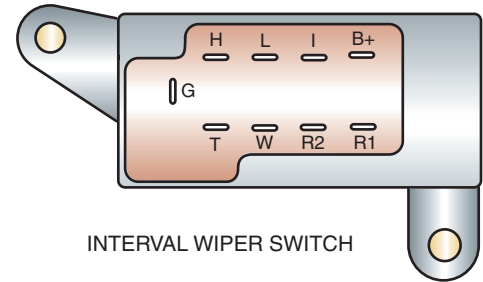
**CAUTION:**

The intermittent wiper system may be a function of the body computer, which may incorporate self-diagnosis. Do not measure resistance through the module; damage to the circuits may result.



STANDARD WIPER SWITCH

Switch position	Continuity between terminals
Off	P and L
Low	B+ and L
High	B+ and H
Wash	B+ and W



INTERVAL WIPER SWITCH

Switch position	Continuity between terminals
Off	No continuity
Interval	B+ and I
Low	B+ and L
High	B+ and H and L

Note: There should be continuity between terminals R1 and R2 throughout variable resistance range

FIGURE 14-13 Wiper switch continuity chart.



**SPECIAL TOOLS**

- Fender covers
- Battery terminal puller
- Battery terminal pliers

**Wiper Motor Removal and Installation**

Removal procedures differ among manufacturers. Some motors are situated in areas that may require the removal of several engine compartment components. Always refer to the correct service manual for the recommended procedure. Photo Sequence 24 provides a common method of removing a wiper motor.



## WIPER MOTOR REMOVAL

All photos in this sequence are © Delmar/Cengage Learning.



**P24-1** Place fender covers over the vehicle's fenders.



**P24-2** Disconnect the battery negative cable.



**P24-3** Disconnect the wiper arms from the linkage.



**P24-4** To gain access to the motor, remove the shield cover from the cowl.



**P24-5** Disconnect the wire connector at the motor.



**P24-6** Remove the linkage from the motor.



**P24-7** Remove the attaching bolts from the motor assembly.



**P24-8** Remove the motor.



### CAUTION:

The internal permanent magnets of the motor are constructed of ceramic material. Use care in handling the motor to avoid damaging the magnets.



### SPECIAL TOOLS

Fender covers  
Battery terminal puller  
Battery terminal pliers

### Classroom Manual

Chapter 14, page 374



### SPECIAL TOOLS

Scan tool  
DMM

On some vehicles, the linkage is removed by lifting the locking tab and pulling the clip away from the pin (refer to Figure 14-6). Installation is basically the reverse of the removal procedure. But be sure to attach the ground wire to one of the mounting bolts during installation.

## Wiper Switch Removal and Installation

The wiper switch removal procedure differs among manufacturers and depends on switch location. The procedures presented here are common. However, always refer to the manufacturer's service manual for correct procedures. Always protect the customer's investment by using fender covers while disconnecting the battery negative cable.

**Dash-Mounted Switches.** Depending on the location of the switch control, it may be necessary to remove the finish panel. Usually the finish panel is held in place by a combination of fasteners and clips.

Remove the switch housing retaining screws. Then remove the housing. Pull off the wiper switch knob. Disconnect the wire connectors from the switch. Remove the switch from the dash.

Reverse the procedure to install the switch.

**Steering Column-Mounted Switches.** Remove the upper and lower steering column shrouds to expose the switch. Disconnect the wire connectors to the switch. It may be necessary to peel back the foam to gain access to the retaining screws. Remove the screws and the switch.

## DIAGNOSING COMPUTER-CONTROLLED WIPER SYSTEMS

Most computer-controlled wiper systems are capable of performing a diagnostic routine and setting of DTCs if a problem is indicated. The following are some common DTCs that are associated with the wiper system and common diagnostic procedures for locating the fault. Use Figure 14-14 as an example of the system.

### Wiper Park Switch Input Circuit Low

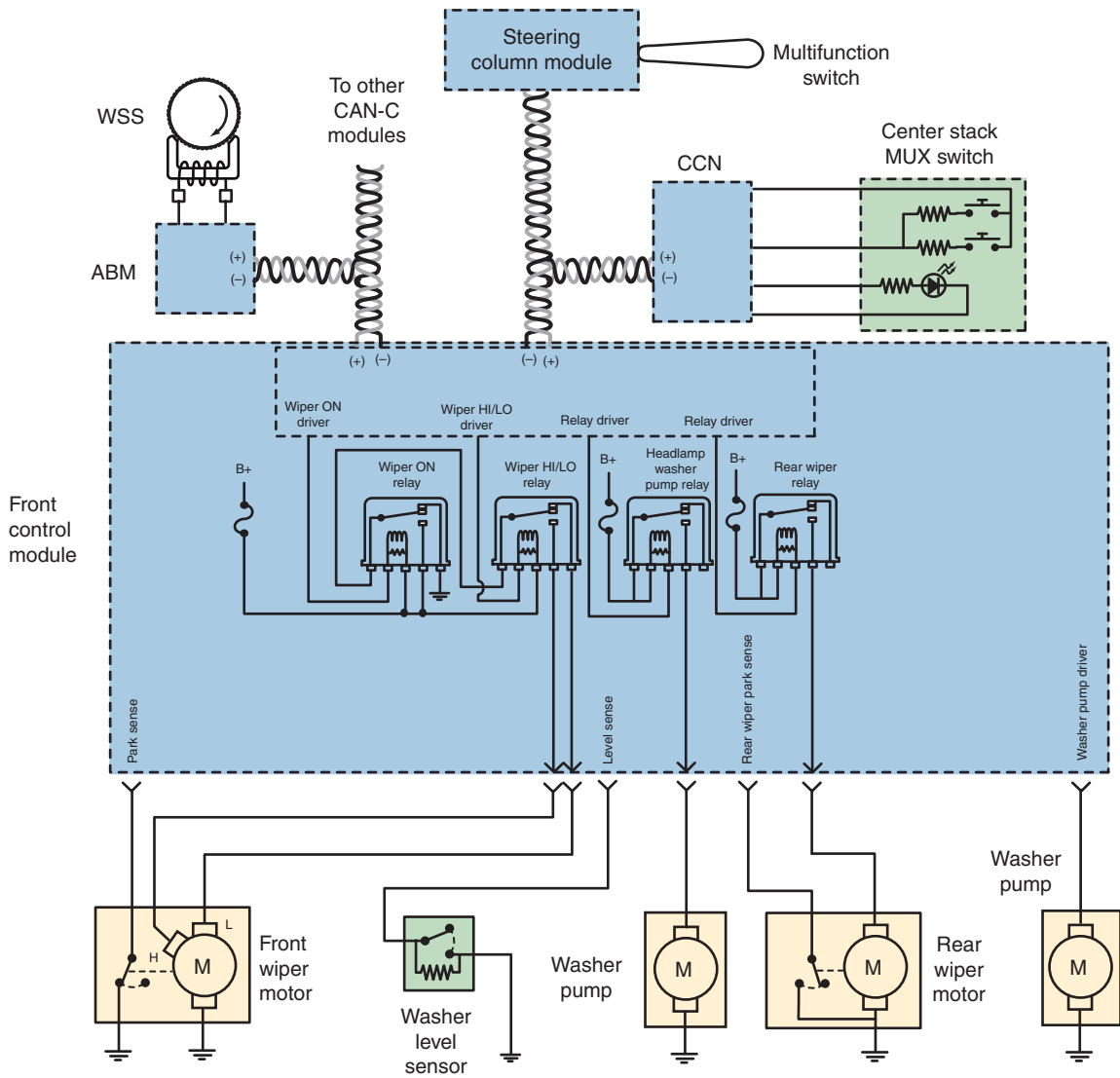
Whenever the ignition switch is in the RUN position and the wipers are requested to be turned ON, the front control module (FCM) monitors the park switch circuit. As the wipers sweep across the windshield and return to their parked position, the switch should cycle from open to closed. If the FCM detects a short to ground condition, then the "Wiper park switch input circuit low" fault is set. This DTC can indicate that the front wiper park switch sense circuit is shorted to ground, or that the wiper motor is faulty (internal park switch failure), or a fault in the FCM. The customer would probably state that the wipers turn off immediately after the switch is set to the OFF position, regardless of the position of the wipers on the windshield.

Begin by inspecting the related wiring for any chafed, pierced, pinched, or partially broken wires. If no faults are found, erase the fault codes and disconnect the front wiper motor harness connector. Turn the ignition to the RUN position and activate the wipers for about 30 seconds, then check for a "Wiper park switch input circuit high" DTC. If this fault code does set, then replace the wiper motor.

If the circuit low fault is set again, measure the resistance between ground and in the wiper park switch sense circuit. If the resistance is below 5 ohms, the circuit is shorted to ground. If there is more than 5 ohms of resistance, replace the FCM.

### Wiper Park Switch Input Circuit High

The "Wiper park switch input circuit high" fault is set when the FCM detects an open circuit. This DTC can also set if the park switch sense circuit is shorted to voltage. This DTC can indicate that the front wiper park switch sense circuit is shorted to ground, or that the wiper motor is faulty (internal park switch failure), or a fault in the FCM. The customer would probably state that the wipers turn off immediately after the switch is set to the OFF position, regardless of the position of the wipers on the windshield.



**FIGURE 14-14** Computer-controlled wiper system.

© Delmar/Cengage Learning

Begin by inspecting the related wiring for any chafed, pierced, pinched, or partially broken wires. If no faults are found, erase the fault codes and disconnect the front wiper motor harness connector and the FCM connector. Measure for voltage on the park switch sense circuit. Since both connectors are disconnected, there should be 0 volts on the circuit. If there is measured voltage, the circuit is short to a voltage supply circuit.

With the connectors still disconnected, measure the resistance in the park switch circuit. The resistance should be close to 0 ohms. If the ohmmeter indicates high resistance or open circuit, repair the sense circuit. If the problem still has not been located, test the park switch ground circuit.

If all tests indicate there is no problem, the fault is the FCM. Be sure to test all connections, power, and ground feeds before condemning the FCM.

### Wiper On/Off Control Circuit Low

The “Wiper On/Off control circuit low” DTC is set if the FCM detects a short to ground or low voltage condition in the ON relay’s control circuit. This could be caused by an open in the fused battery feed circuit to the relay, a faulty relay coil, an open in the control circuit

between the relay and the FCM, or a short to ground in the control circuit. In addition, the FCM may be the faulty component. The customer would probably state that their wipers do not work in any switch position.

Begin by checking the condition of the fuse that protects the voltage supply circuit to the relay. If the fuse is blown, then there is a short to ground in the circuit between the fuse and the relay, or the relay coil is shorted. If the fuse is good, replace the relay with a known good unit and test operation. If the wipers still do not operate, continue testing by removing the relay and turning the ignition to the RUN position. Measure for voltage at cavity 86 of the relay. If the voltage is not the same as battery voltage, there is an open or high resistance in the circuit. It is always a good practice to load the circuit when testing. Removing the relay means that the test is an open-circuit test. Load the circuit with a test light and measure available voltage.

If the fault has not yet been located, reinstall the relay and backprobe the relay control circuit at the FCM. Measure the voltage at this location. If the voltmeter reads 0 volts, there is an open between the relay and the FCM. If the voltage reads battery voltage, use a jumper wire to jump the backprobed connector to ground. If the wipers come on during this test, the FCM has a faulty driver.

**AUTHOR'S NOTE: The input from the multifunction switch is not being tested because of the fault code retrieved. In this instance, the DTC indicates the problem area as being the relay control circuit. If the wipers did not operate and there were not any DTCs, then the input side would be tested.**

## Wiper On/Off Control Circuit High

The “Wiper On/Off control circuit high” DTC is set if the FCM detects a short to voltage condition in the ON relay’s control circuit. This could be caused by a shorted relay coil, or an internal fault with the FCM. The customer would probably state that their wipers do not work in any switch position.

To test for this type, begin by erasing the fault codes and replace the relay with a known good unit. Operate the system for about 30 seconds then turn it off. Use the scan tool to see if the DTC returned. If it did not return, the relay was the problem. If the DTC did return, the FCM is faulty. Be sure to test all connections, powers, and grounds before faulting the FCM.

## Wiper HI/LOW Control Circuit Low

The “Wiper HI/LOW control circuit low” DTC is set when the FCM detects a short to ground or low voltage condition on the HI/LOW relay control circuit. When the driver in the FCM is turned off, the FCM should sense 12 volts on the control circuit. When the driver is turned on, the voltage should go to about 700 mV. If the voltage is always low on this circuit, the FCM will set the code. The customer will probably state that their wipers work on low and intermittent speeds, but not on high speed. Causes for this fault to set include an open battery feed circuit, open relay coil, short to ground in the control circuit, and an internal problem within the FCM.

**AUTHOR'S NOTE: If the control circuit is shorted to ground between the relay and FCM, the customer will probably state that the wipers appear to be working on high speed only.**



Begin by testing all fuses associated with the relay control circuit. Referring back to Figure 14-17, if the wipers work on low speed but not on high speed, the problem is between the common splice in the 12-volt feed circuit and the FCM.

Remove the HI/LOW relay and measure the voltage at cavity 86 with the ignition in the RUN position. It would be best to load the circuit with a test light when measuring this voltage. If the voltage is about equal to battery voltage, the circuit to this point is good. If the voltage is 0 volts, there is an open in the circuit toward the common splice.

Replace the relay with a known good unit and clear all DTCs. Attempt to operate the wipers on high speed; then turn the wipers off again. Use the scan tool to read DTCs; if the fault code did not come back, the relay was the problem, if the fault did come back, then check the circuit between the relay and the FCM for an open or short to ground.

Backprobe the FCM connector for the HI/LO relay control circuit. With the wipers operating on low speed, jump the backprobed terminal to ground. If the wipers go to high speed, the fault is in the FCM. If the wipers still do not operate on high speed, check from an open in the relay control circuit between the relay and the FCM.

## Wiper HI/LOW Control Circuit High

The “Wiper HI/LOW control circuit high” DTC is set when the FCM detects a short to voltage or high voltage condition on the HI/LOW relay control circuit. When the driver in the FCM is turned off, the FCM should sense 12 volts on the control circuit. When the driver is turned on, the voltage should go to about 700 mv. If the voltage is always high on this circuit, the FCM will set the code. The customer will probably state that their wipers work on low and intermittent speeds, but not on high speed. Causes for this fault to set include a short to battery voltage on the circuit between the relay and the FCM, a faulty relay, or an internal problem within the FCM.

Begin erasing all DTCs and replacing the relay with a known good unit. Operate the wipers for about 30 seconds, and then turn them off. Check to see if the DTC returned; if not, then the relay was the problem. If the DTC returned, test for voltage on the circuit between the relay and the FCM by disconnecting the connector on both ends and measuring for voltage. If there is a measured voltage, then isolate the shorted circuit and repair. If the circuit is not shorted to voltage, replace the FCM.

## AUTOMATIC WIPER SYSTEM DIAGNOSIS

A vehicle that is equipped with the automatic wiper system uses the same type of computer-controlled wipers, but adds a rain sensor. Also, when automatic wipers are enabled, the intermittent position on the multifunction switch control knob is used to set the desired system sensitivity. Using the schematic of an automatic wiper system (Figure 14-15), you can see that the right multifunction switch is a mux switch to the left multifunction switch, which is a LIN slave module to the cabin compartment node (CCN). The electronic wiper switch sensitivity message is sent to the CCN over the LIN data bus, and then the CCN relays the message to the rain sensor module (RSM) over the CAN B data bus. The RSM monitors an area within the wipe pattern of the windshield glass for the accumulation of moisture. Based upon internal programming and the selected sensitivity level, when sufficient moisture has accumulated, the RSM sends the appropriate electronic wipe command messages to the FCM over the CAN B data bus. The FCM operates the front wiper system accordingly.

**Classroom  
Manual**

Chapter 14, page 375



### SPECIAL TOOLS

Scan tool  
DMM

**AUTHOR'S NOTE:** The CCN is another term used to describe the electronic instrument cluster when it is a dominant module on the CAN bus network.

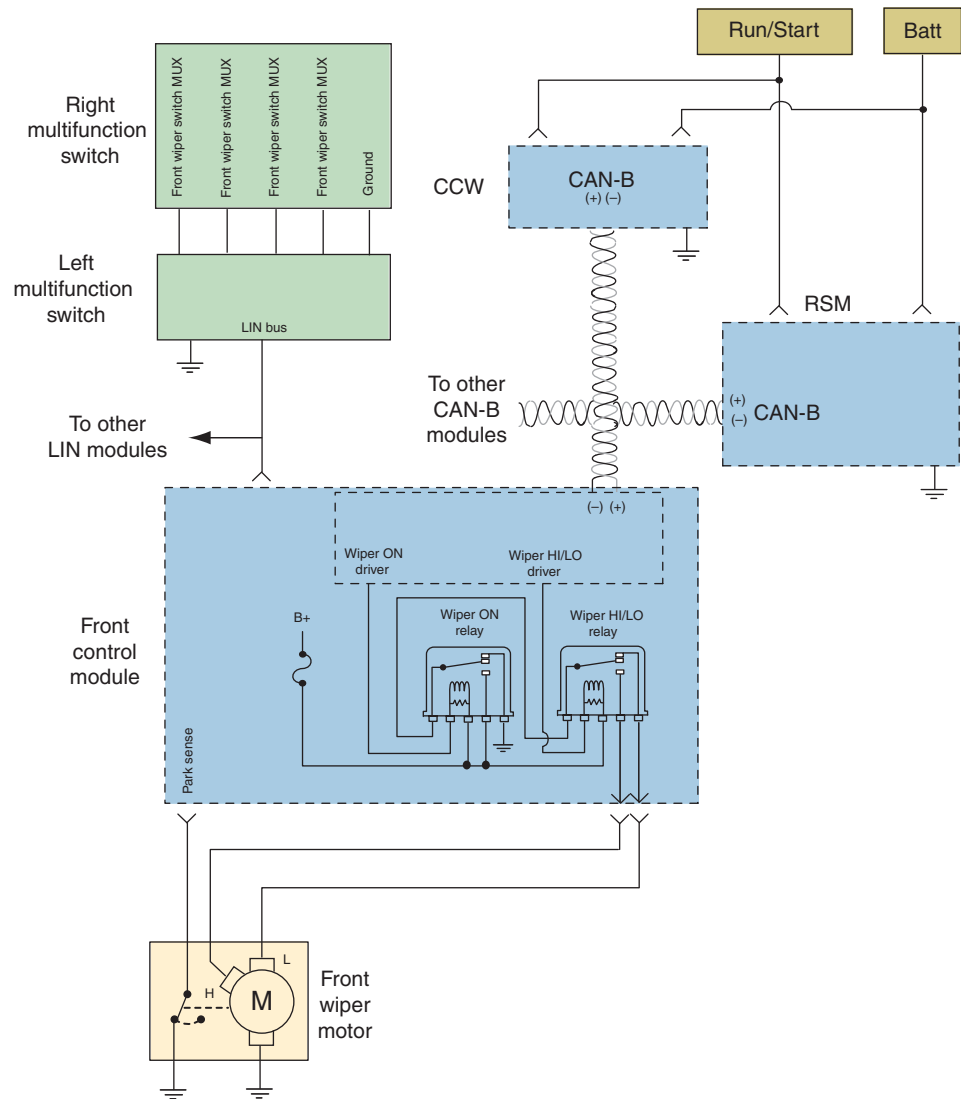


FIGURE 14-15 Automatic wiper system.

© Delmar/Cengage Learning

If the wipers do not operate properly in manual mode or automatic mode, the problem is in the basic wiper system. If the wipers operate properly in the manual mode, but not in the automatic mode, then the problem is in the automatic function components. This includes the RSM and the data bus network to it. It is also possible that the system is disabled.



**WARNING:** To avoid serious or fatal injury, disable the supplemental restraint system (SRS) before attempting any diagnosing or removal of parts on the steering wheel, steering column, or instrument panel. Disconnect and isolate the battery negative (ground) cable, then wait two minutes for the system capacitor to discharge before performing further diagnosis or service. Failure to follow this warning could result in accidental air bag deployment.



The hard-wired wiper system circuits and components may be diagnosed using conventional diagnostic tools and procedures. However, conventional diagnostic methods will not prove conclusive in the diagnosis of the front wiper and washer system or the electronic controls or communication between other modules and devices that provide the automatic wiper feature. The most reliable, efficient, and accurate means to diagnose the front wiper and washer system or the electronic controls and communication related to front wiper and washer system operation requires the use of a diagnostic scan tool.

A problem that the customer may experience with automatic wiper systems is called **false wipes**. False wipes are unnecessary wipes that occur when the automatic wiper system is enabled but there is no apparent rain or moisture on the windshield. When diagnosing this type of complaint, keep in mind that the system is designed to operate whenever it detects moisture. Any road spray, bug splatters, or mist from passing vehicles may cause the wipers to cycle. These are normal characteristics of this system and are not false wipes.

False wipes are usually the result of a foreign material on the windshield. In some instances, they can result from flaws in the windshield that interferes with the system optics. Anything that distorts the intensity of the IR light beams or affects the ability of the photo diodes to accurately measure the returning beams can result in the RSM logic misinterpreting the input data as moisture on the windshield. The optics for this system includes the lenses of the RSM, the lenses of the RSM bracket, the adhesive pad layer that bonds the bracket to the inside of the windshield, and the windshield glass.

Usually the system can detect faults in the electronics or bus communications that may cause the system to not function properly. Use a scan tool to check for DTCs associated with the front wiper system, the multifunction switch, the CCN, and the RSM. If there are any DTCs in the components that operate within the system, use the appropriate diagnostic procedures to isolate the problem. If no DTCs are present, then perform the routine illustrated in Photo Sequence 25. If a problem is found within the RSM mounting bracket, it is usually serviced as a unit with the windshield glass. If either the bracket or the windshield glass is the cause of the system problem, the entire RSM bracket and windshield glass unit must be replaced.

## WINDSHIELD WASHER SYSTEM SERVICE

Many windshield washer problems are due to restrictions in the delivery system. To check for restrictions, remove the hose from the pump and operate the system. If the pump ejects a stream of fluid, then the fault is in the delivery system. If the pump does not deliver a spray of fluid, continue testing using the following procedure:

1. Make checks of obvious conditions such as low fluid level, blown fuses, or disconnected wires.
2. Activate the washer switch while observing the motor. If the motor operates but does not squirt fluid, check for blockage at the pump. Remove any foreign material. If there is no blockage, then replace the motor.
3. If the motor does not operate, use a voltmeter or test light to check for voltage at the washer pump motor with the switch closed. If there is voltage, then check the ground circuit with an ohmmeter. If the ground connection is good, then replace the pump motor.
4. If there is no voltage to the pump motor in step 3, trace the circuit back to the switch. Test the switch for proper operation. If there is power into the switch but not out of it to the motor, replace the switch.

### Classroom Manual

Chapter 14, page 376



### SPECIAL TOOLS

Fender covers  
Voltmeters  
Test light  
Ohmmeter  
Safety glasses

# PHOTO SEQUENCE 25

## INSPECTION OF RAIN SENSOR MODULE

All photos in this sequence are © Delmar/Cengage Learning.



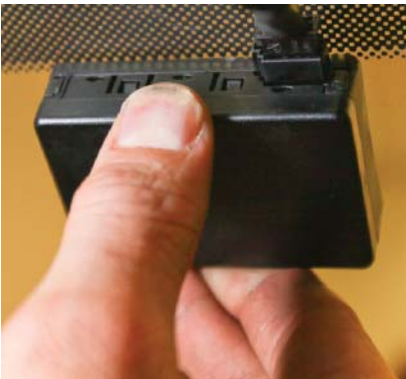
**P25-1** Carefully inspect the outer surface of the windshield glass for physical damage, including scratches, cracks, or chips in the vicinity of the RSM mounting bracket lenses. If damage is present, replace the windshield.



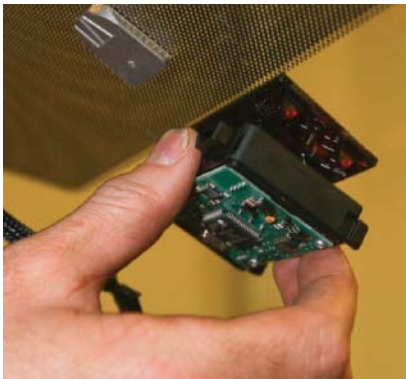
**P25-2** From the outside of the windshield glass, carefully inspect the adhesive layer between the windshield glass and the RSM bracket for any voids greater than 0.040 inch (1 millimeter). If an adhesive void is detected, replace the flawed RSM mounting bracket and windshield unit.



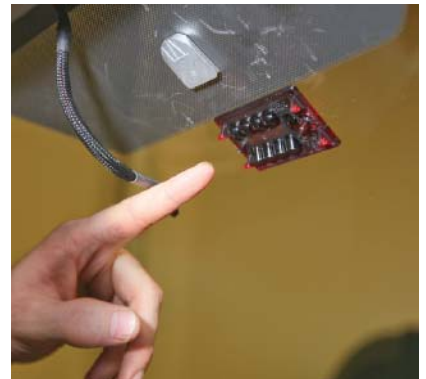
**P25-3** Remove the inside rear view mirror.



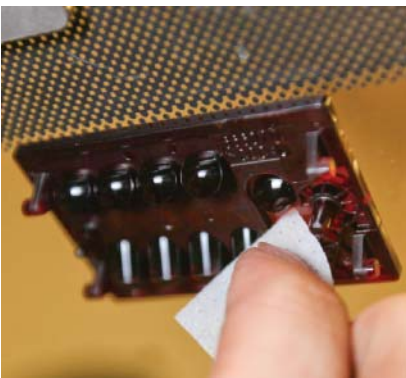
**P25-4** Lightly pull the RSM away from the windshield bracket to confirm that both module sliding cam locks are fully engaged with all four pins of the mounting bracket on the inside of the windshield glass. If needed, reinstall the module onto the bracket.



**P25-5** Remove the RSM from the mounting bracket.



**P25-6** Inspect the RSM lenses and the mounting bracket lenses for contamination.



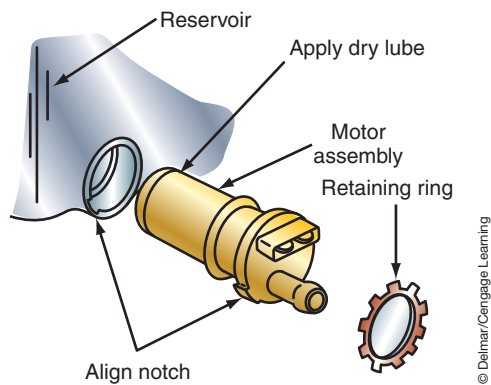
**P25-7** Clean any foreign material from each of the lenses using rubbing alcohol and a lint-free cloth.



**P25-8** Carefully inspect the RSM for any physical damage, including scratches on the RSM lenses.



**P25-9** Carefully inspect the RSM mounting bracket for any physical damage, including scratches on the RSM bracket lenses. If any damage is found, replace the bracket and windshield as a unit.



**FIGURE 14-16** Reservoir-mounted washer pump and motor.

If the motor is in need of replacement, follow this procedure for pumps installed in the reservoir (Figure 14-16). Disconnect the wire connector and hoses from the pump. Remove the reservoir assembly from the vehicle. Use a small blade screwdriver to pry out the retainer ring.



**WARNING:** Wear safety glasses to prevent the ring from striking your eyes. Also be careful to position the palm of your hand so that if the screwdriver slips it will not puncture your skin.

Use a pair of pliers to grip one of the walls that surrounds the terminals. Pull out the motor, seal, and impeller.

Before installing the pump assembly, lubricate the seal with a dry lubricant. The lubricant is used to prevent the seal from sticking to the wall of the reservoir. Align the small projection on the motor with the slot in the reservoir and assemble. Make sure the seal seats against the bottom of the motor cavity. Use a 12-point, 1-in. socket to hand press the retaining ring into place.

Replace the reservoir assembly in the vehicle. Reconnect the hose and wires. When refilling the reservoir, do so slowly to prevent air from being trapped in the reservoir. Check system operation while checking for leaks.

## BLOWER MOTOR SERVICE

Conventional blower motor speed is controlled by sending current through a **resistor block**. The resistor block is a series of resistors with different values. There is usually one less resistor than there are fan speed positions because the high-speed circuit bypasses the resistors. The higher the resistance value, the slower the fan speed. The position of the switch determines which resistor will be added to the circuit. Circuits can use either ground side switches or insulated side switches.

If the customer complaint is that the fan operates in only a couple of speed positions, the most likely cause is an open resistor in the resistor block. Using the illustration (Figure 14-17), if resistor 1 is open, the motor will not operate in any position except high speed. If resistor 2 was open, the motor would operate in high and M2 speeds only. If resistor 3 was open, the motor would operate in all speeds except low.

If the motor operates in any one of the speed select positions, the fault is not in the motor. If the motor fails to operate at all, begin by inspecting the fuse. If the fuse is good, use the



### CAUTION:

Do not operate the washer pump without fluid. Doing so may damage the new pump motor.

### Classroom Manual

Chapter 14, page 379



### SPECIAL TOOLS

Jumper wires  
Test light  
Voltmeter  
Fender covers

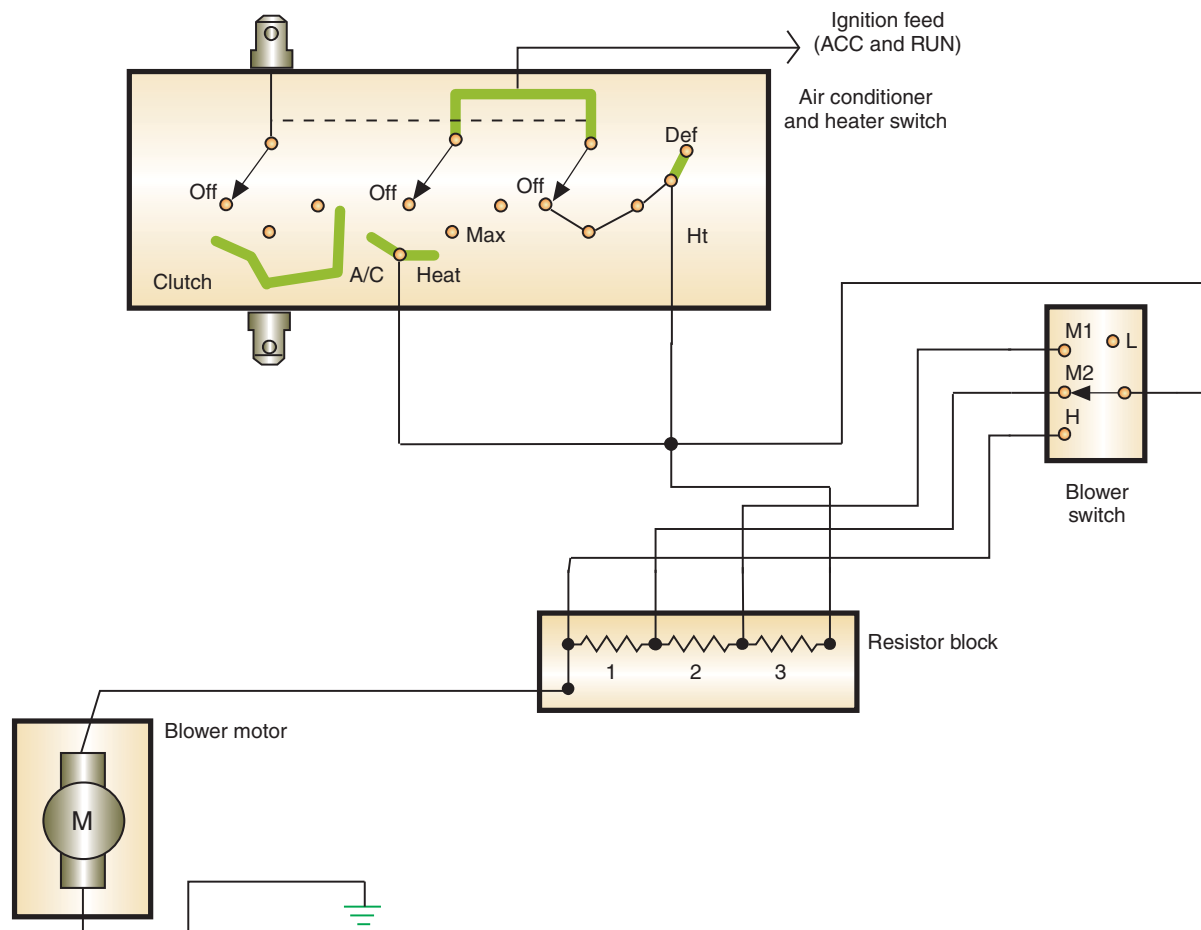


FIGURE 14-17 Typical wiring for a four-speed fan motor circuit.

© Delmar/Cengage Learning



### SERVICE TIP:

Because the high-speed circuit bypasses the resistor block, it is doubtful that no motor operation would be the fault of open resistors. However, an open in the wire from the block to the motor can cause the problem. Most likely the switch is bad and in need of replacement. Always confirm your diagnosis by doing a continuity test on the switch.

correct wiring schematic to determine whether ground or insulated side switches are used. The diagnostic procedure used depends on the circuit design.

### Inoperable Motor with Insulated Switches

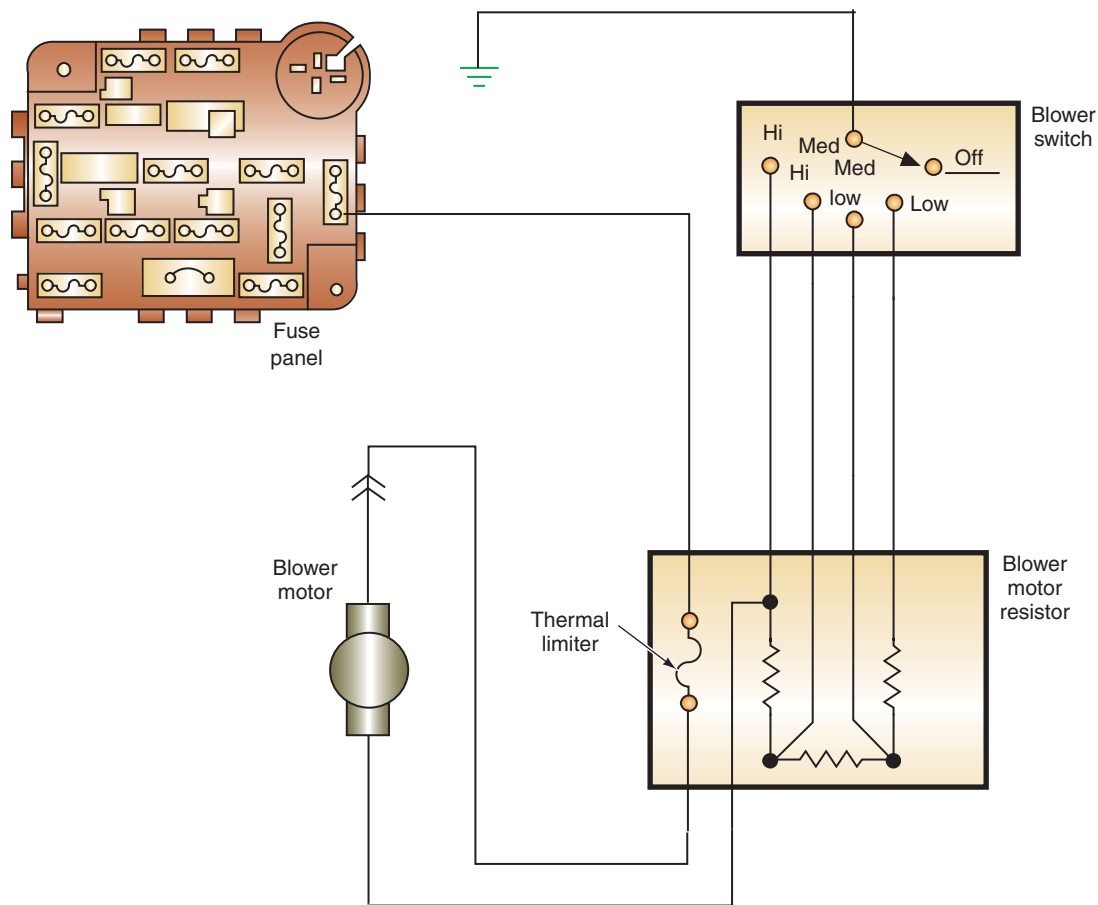
Use a jumper wire to bypass the switch and resistor block to check motor operation. Connect the jumper wire from a battery positive supply to the motor terminal. If the motor does not operate, connect a second jumper wire from the motor body to a good ground. Replace the motor if it still does not operate.

If the motor operated when the switch and resistor block were bypassed, trace up the circuit toward the switch. Use a voltmeter or test light to check for voltage in and out of the blower speed control switch. The switch is faulty if voltage is at the input terminal but not at any of the output terminals. No voltage at the input terminal indicates an open in the circuit between the battery and the switch.

### Inoperable Motor with Ground Side Switches

Using the illustration (Figure 14-18) as an example of negative side switch blower motor circuit to test the motor, connect the jumper wire from the motor negative terminal to a good ground. This bypasses the switch and resistor block. If the motor does not operate, use a voltmeter or test light to check for voltage at the battery terminal of the motor. If voltage is present, then the motor is defective.





**FIGURE 14-18** Blower motor circuit using negative side switch.

© Delmar/Cengage Learning



**CAUTION:**

The resistor block is mounted in the heater/air conditioning housing where it is cooled by air flow from the fan. Do not run the fan motor with the resistor block removed from the air flow because it may overheat and burn the coils.

If there is no voltage at the battery terminal of the motor, the problem is in the circuit from the battery to the motor. Be sure to check the circuit breaker.

Operation of the motor when the jumper wire is connected to the ground terminal indicates the problem is in the switch side of the circuit. Use an ohmmeter to check the ground connection for the switch. A jumper wire or test light can also be used to test this connection.

If the ground connection is good, use a voltmeter or test light to probe for voltage at any of the circuits from the resistor block to the switch. Replace the switch if there is power to this point. Replace the resistor block if there is no power at these points.

**Constantly Operating Blower Fans**

Constantly running blower motors are more common in ground side switch systems. A short to ground at any point on the ground side of the circuit will cause the motor to run. Other areas to check include the switch and the circuit between the switch and the resistor block.

In insulated side switch circuits, check for copper-to-copper shorts in the power side of the system. If the motor is receiving power from another circuit, due to a copper-to-copper short, the motor will continue to run whenever current is flowing through that circuit. Some systems may incorporate a relay, and if the contact points fuse together, the motor will continue to operate.

General Motors designed many of its blower fans to constantly operate. Do not confuse this normal operation with a circuit defect.



**SPECIAL TOOLS**

- Test light
- Grease pencil
- Heat gun or blow-dryer
- Defogger repair kit
- Test light
- Masking tape
- Clean cloth
- Wooden stick
- Alcohol
- Steel wool



**CAUTION:**

Be careful not to tear the grid with the test light. Only a light touch on the grid should be required.

**ELECTRIC DEFOGGER DIAGNOSIS AND SERVICE**

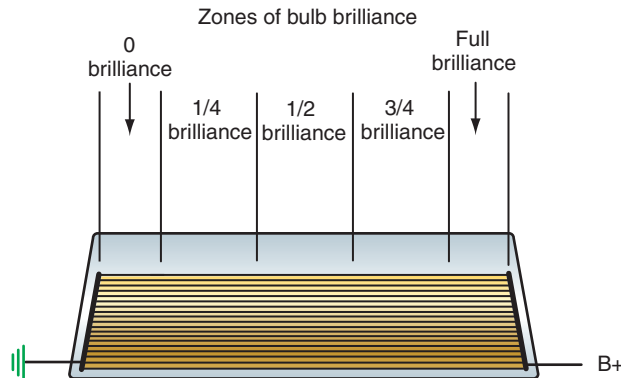
If the rear window defogger fails to operate when the switch is activated, use a test light to test the **grids**. The rear window defogger grids are a series of horizontal, ceramic, silver-compounded lines that are baked into the surface of the window. Under normal conditions, the test light should be bright on one side of the grid and off on the other side. If the test light has full brilliance on both sides of the grid, then the ground connection for the grid is broken.

If the test light does not illuminate at any position on the grid, use normal test procedures to check the switch and relay circuits. There may be several fuses involved in the system. Use the correct wiring diagram to determine the fuse identification.

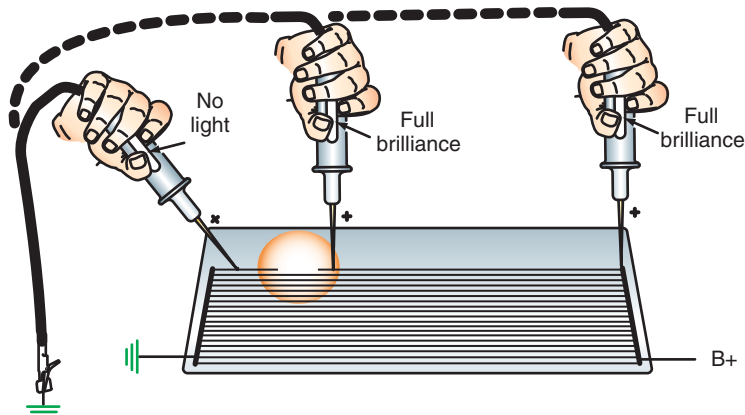
Most rear window defogger complaints will be associated with broken grids. These will generally be complaints that only a portion of the window is cleared while the rest remains foggy. Some grid wire breaks are easily detected by visual inspection. However, many are too small to see. To test the grid lines, start the engine and activate the system. (Remember, the system is controlled by a timer.) Use a test light to check each grid wire to locate the breaks. Test each grid in at least two places—one on each side of the center line. The test results that should be obtained on each grid are illustrated (Figure 14-19).

If the test light does not indicate normal operation on a specific grid line, place the test light probe on the grid at the left bus bar and work toward the right until the light goes out. The point where the light goes out is the location of a break (Figure 14-20). Mark the location of the break with a grease pencil on the *outside* of the glass.

The rear window defogger should turn off about 10 minutes after activation. If the circuit fails to turn off, check the ground for the control module (Figure 14-21). If the ground is good, replace the module.



**FIGURE 14-19** Zones of test light brilliance while probing a rear window defogger grid.



**FIGURE 14-20** Test light brilliance when passed over a break.



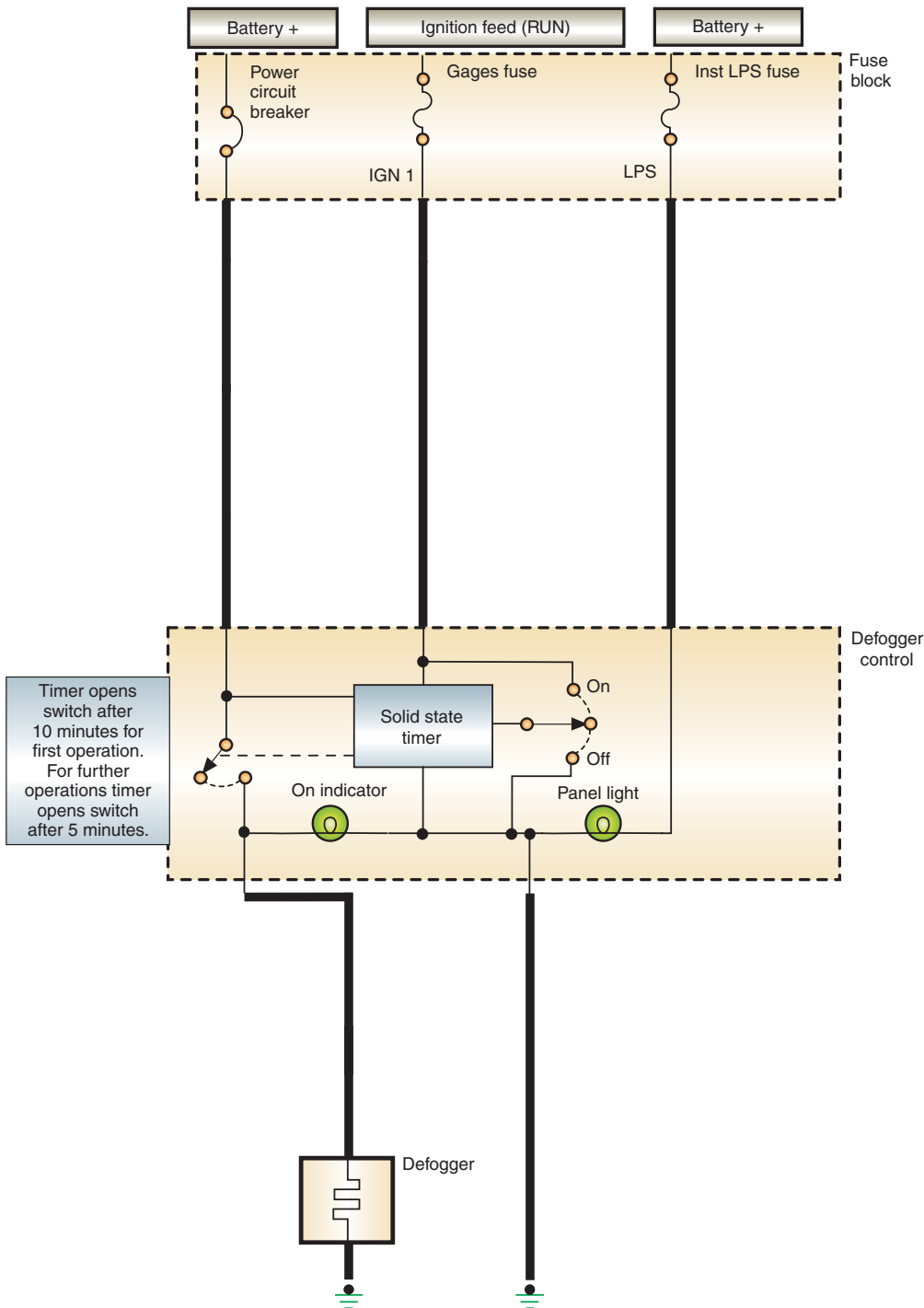


FIGURE 14-21 The defogger control incorporates a solid state timer circuit.

© Delmar/Cengage Learning

Some manufacturers refer to the rear window defogger system as electric backlight (EBL).



**SPECIAL TOOLS**

- Soldering iron
- Rosin flux paste
- 3% silver solder
- Steel wool

To **tin** the tip is a process of applying solder to the tip of the soldering iron to provide better heat-control.

**Grid Wire Repair**

If the grid wire is broken, it is possible to repair the grid with a special repair kit. Follow the procedures in Photo Sequence 26 to repair the grid.

**Bus Bar Lead Repair**

The bus bar lead wire can be resoldered using a solder containing 3% silver and a rosin flux paste. Clean the repair area using a steel wool pad. Apply the rosin flux paste in small quantities to the wire lead and bus bar. **Tin** the solder iron tip with the solder. Finish the repair by soldering the wires to the bus bar. Be careful not to overheat the wire.

## PHOTO SEQUENCE 26

### TYPICAL PROCEDURE FOR GRID WIRE REPAIR

All photos in this sequence are © Delmar/Cengage Learning.



**P26-1** Tools required to perform this task include masking tape, repair kit, 500°F heat gun, test light, steel wool, alcohol, and a clean cloth.



**P26-2** Clean the grid line area to be repaired by buffing with steel wool and wiping clean with a cloth dampened with alcohol. Clean an area about 1/4 inch (6 mm) on each side of the break.



**P26-3** Position a piece of tape above and below the grid. The tape is used to control the width of the repair.



**P26-4** Mix the hardener and silver plastic thoroughly. If the hardener has crystallized, immerse the packet in hot water.



**P26-5** Apply the grid repair material to the repair area using a small stick.



**P26-6** Remove the tape.



**P26-7** Apply heat to the repair area for 2 minutes. Hold heat gun 1" (25 mm) from the repair.



**P26-8** Inspect the repair. If it is discolored, apply a coat of tincture of iodine to the repair. Allow to dry for 30 seconds, then wipe off the excess with a cloth.



**P26-9** Test the repair with a test light. Note: It takes 24 hours for the repair to fully cure.

## POWER WINDOW DIAGNOSIS

Usually the door panel will need to be removed to gain access to the window motor and regulator. There are several methods used to attach the trim panel to the door frame. Common methods include screws, push pins, clips, and “L” brackets.

Figure 14-22 illustrates a typical door panel removal procedure. Begin by locating and removing any screws that fasten the panel to the frame. This panel uses “L” hooks molded into the panel. This requires the panel to be lifted off the attachment hooks and the lock rod at the same time in order to remove the panel. Once the panel is no longer attached to the door frame, disconnect any electrical connectors and actuating rods to free the panel. Lay the panel on a clean work bench and protect it from damage.

If the trim panel is attached with push pins, use a trim stick to gently pry the panel from the frame. Be sure to have the push pins properly aligned with their receiver holes prior to pushing the panel back into position on the frame.

Use the illustration (Figure 14-23) as a guide to diagnosing the power window circuit. If the window does not operate, begin by testing the circuit breaker. Use a test light or voltmeter to test for voltage at both sides of the circuit breaker. If voltage is present at both sides, then the circuit breaker is good. If there is voltage into the circuit breaker but not out of it, the circuit breaker is faulty. If there is no voltage into the circuit breaker, then there is an open in the feed from the battery.

If the circuit breaker is good, use jumper wires to test the motor. The motor is a reversible motor, so connections to the motor terminals are not polarity sensitive. Disconnect the wire connectors to the motor. Connect battery positive to one of the terminals and ground the other. If the motor does not operate, reverse the jumper wire connections. The motor should reverse directions when the polarity is reversed. If the motor does not operate in one or both directions, it is defective and needs to be replaced.

**WARNING:** Do not place your hands into the window’s operating area. Make the final test connections outside of the door where there is no danger of getting caught in the window track.

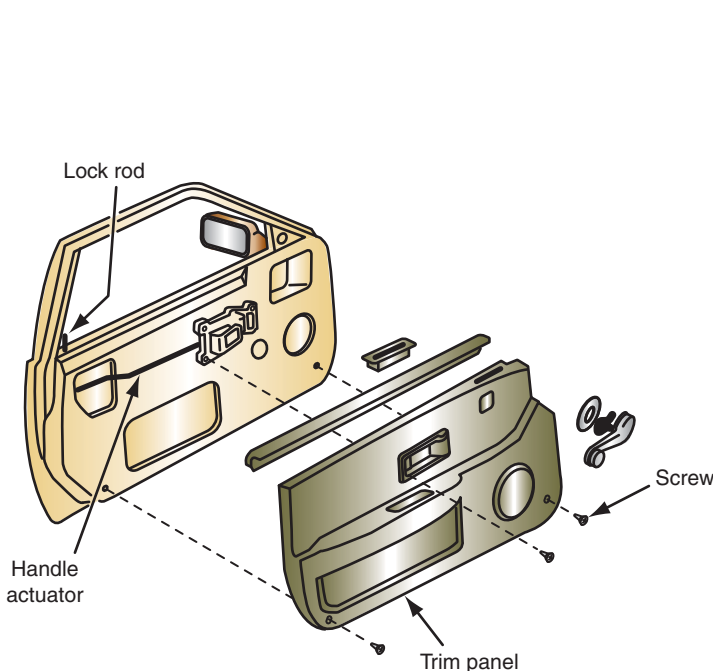


FIGURE 14-22 Door panel attachment.

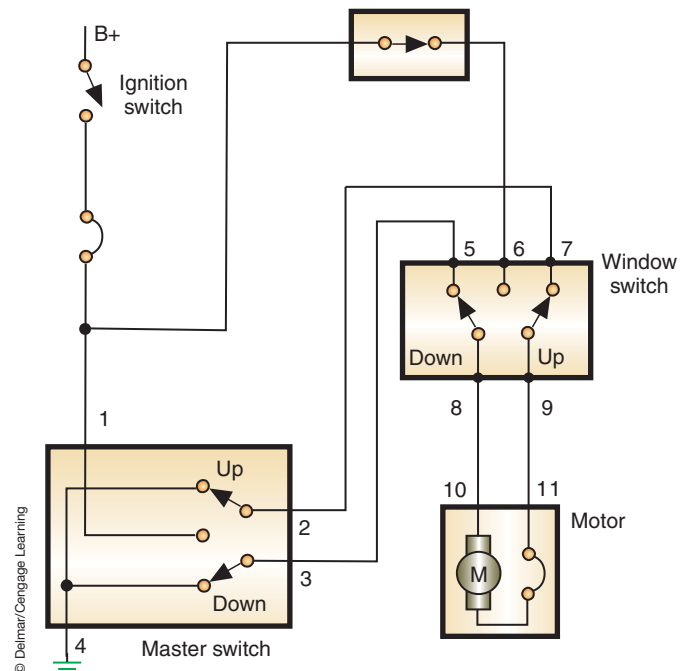


FIGURE 14-23 Simplified power window circuit.



### SPECIAL TOOLS

Test light  
Voltmeter  
Jumper wires



### CAUTION:

Study the service information prior to attempting to remove the panel. Sometimes there will be hidden screws. Failure to remove these screws before attempting to pull the panel will result in panel damage.



### SERVICE TIP:

It does not matter if the motor or the switches are tested next. Test the unit that is easiest to get to first.

The circuit used in this example is typical. However, use the service manual for the vehicle you are working on to get the correct wiring schematic.

If the motor operates when the switches are bypassed, the problem is in the control circuit. To test the master switch, connect the test light between terminals 1 and 2 (Figure 14-24). When the master switch is in the rest (OFF) position, the test light should illuminate. If the light does not glow, there is an open in the circuit to the window switch or from the window switch to ground at terminal 4. Check the ground at terminal 4 for good connections. If good, continue testing.

If the test light illuminates when connected across terminal 1 and 2, place the switch in the UP position. The test light will go out if the switch is good. Repeat the test between terminals 1 and 3. Place the switch in the DOWN position.

If the master switch is good, test the window switch. Battery voltage should be present at terminal 6. If not, check to see if the lockout switch is closed. Check the circuit from terminal 6 to the circuit breaker. Connect the test light across terminals 5 and 6 (Figure 14-25). The light should come on. Move your test light to connect between terminals 6 and 7. Again, the test light should come on. Next, connect the test light between terminals 8 and 9 of the window switch. With the switch in the “at rest” position, the test light should be off. Placing the window switch in either the UP or DOWN positions should illuminate the test light. If the light does not come on, you will need to isolate the problem. It may be the switch, the circuits between the switch and the motor, or the motor itself. Use common test methods to determine the fault.

Slower-than-normal operating speeds are an indication of excessive resistance or of binding in the mechanical linkage. Use the voltage drop test method to locate the cause of excessive resistance. Excessive resistance can be in the switch circuits, the ground circuit, or in the motor. If the problem is mechanical, lubricate the track and check for binding or bent linkage.



**WARNING:** Follow the manufacturer’s recommended procedure when removing the power window motor. The springs used in window regulators can cause serious injury if removed improperly.

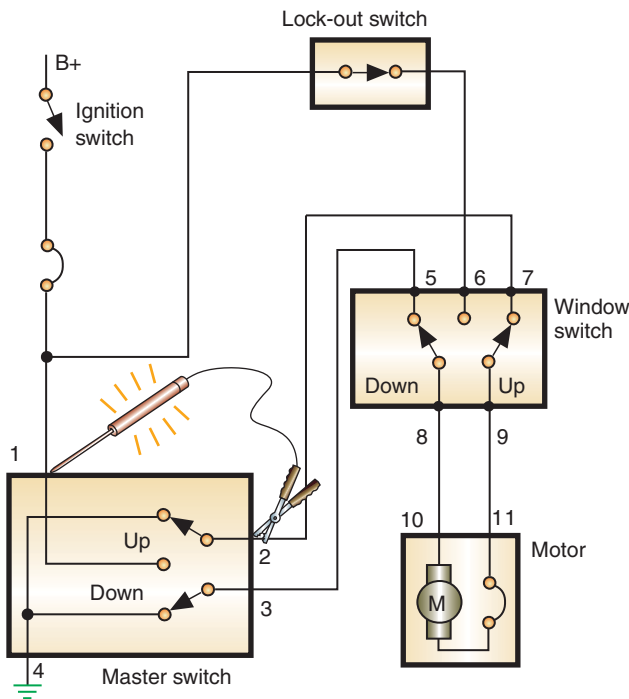


FIGURE 14-24 Using a test light to check the operation of a power window master switch.

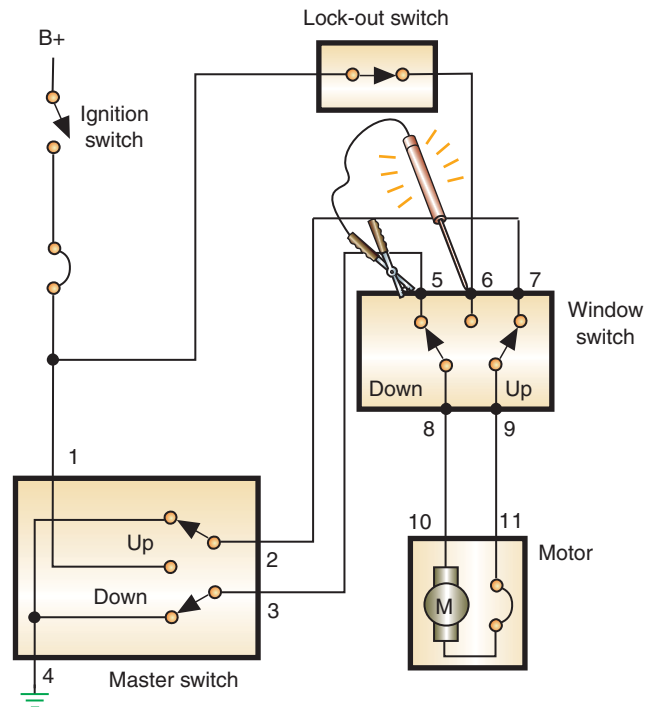


FIGURE 14-25 Test light connections for testing the window switch.

**CUSTOMER CARE:** Testing and repair of the power window system will usually require the door panels to be removed. There are several methods used by manufacturers to secure the door panel. Always refer to the proper service information to determine the correct methods of removal and installation of the panel to prevent damage. Also, use new clips (if applicable) to assure a tight connection and eliminate noise from the panel. Most doors will have a sound dampening material behind the panel. Therefore, you must remember to reinstall this material.

## POWER SEAT DIAGNOSIS

The power seat system is usually very simple to troubleshoot. Test for voltage to the input of the switch control. If voltage is available to the switch, remove it from the seat or arm rest. Using a continuity chart from the service manual, test the switch for proper operation. If the switch is operating properly, it may be necessary to remove the seat to test the motors and circuits to the motors.

The power seat motors are tested in the same manner as the power window motor. Be sure to test each armature of the trimotor. If any of the armatures fail to operate, the trimotor must be replaced as a unit.



**WARNING:** Be careful when making the jumper wire connection to test the motor. Do not place your hands in locations where they can become pinched or trapped when the seat moves.



**WARNING:** If the trimotor needs to be replaced, follow the manufacturer's service procedures closely. Improper removal of the springs may result in personal injury.

Noisy operation of the seat can generate from the motor, transmission, or cable. If the motor or transmission is the cause of the noise, it must be replaced. A noisy cable can usually be cured with a dry lubricant, provided the cable is not damaged.

If the valve holds vacuum, press the pedal. The vacuum should be released. If not, adjust the dump valve according to the service manual procedures. If the dump valve fails to release vacuum when the brake is applied and it is properly adjusted, it must be replaced.

## MEMORY SEAT DIAGNOSIS

If the seat motors fail to operate under any condition, test the motors and switches as outlined earlier. This section relates only to that portion of the system that operates the memory function.

Most modern memory seat systems provide diagnostics by use of a scan tool. Although not all systems store fault codes, the scan tool can usually be used to check inputs and perform actuator tests. If the seat operates properly when the power seat switches are used, but not the memory feature, the problem is either the inputs or the memory seat control module. Use the scan tool to check the inputs from all switches. Also, test the input from the keyless entry system if it is tied into the memory seats. If the scan tool indicates that the inputs are operating properly, check the connector from the control module to the motors. Also, check the powers and ground for the module. If these are good, replace the module.

If the memory seat system does not support scan tool diagnostics, the problem must be isolated using basic electrical diagnostics. The following is a typical example of testing the

### Classroom Manual

Chapter 14, page 389



### SPECIAL TOOLS

Jumper wires  
Ohmmeter  
Test light  
Voltmeter

### Classroom Manual

Chapter 14, page 392



### SPECIAL TOOLS

Test light  
DMM  
Scan tool  
Service manual



system. You will need to reference the proper service information for the vehicle being diagnosed in order to determine what voltage values are used and which circuits to test.

Using the illustration (Figure 14-26) of a memory seat circuit, this system would be diagnosed as follows: All tests are performed at memory seat module connectors C1 and C3. The connectors are disconnected from the module to perform the tests. Place the ignition switch in the RUN position with the gear selector in the PARK position.

With the test light connected between C1 connector terminal B and ground, the lamp should illuminate. If the light does not come on, check for a circuit fault in the battery feed circuit. Connect the test light between terminals A and B at the C1 connector. If the test light

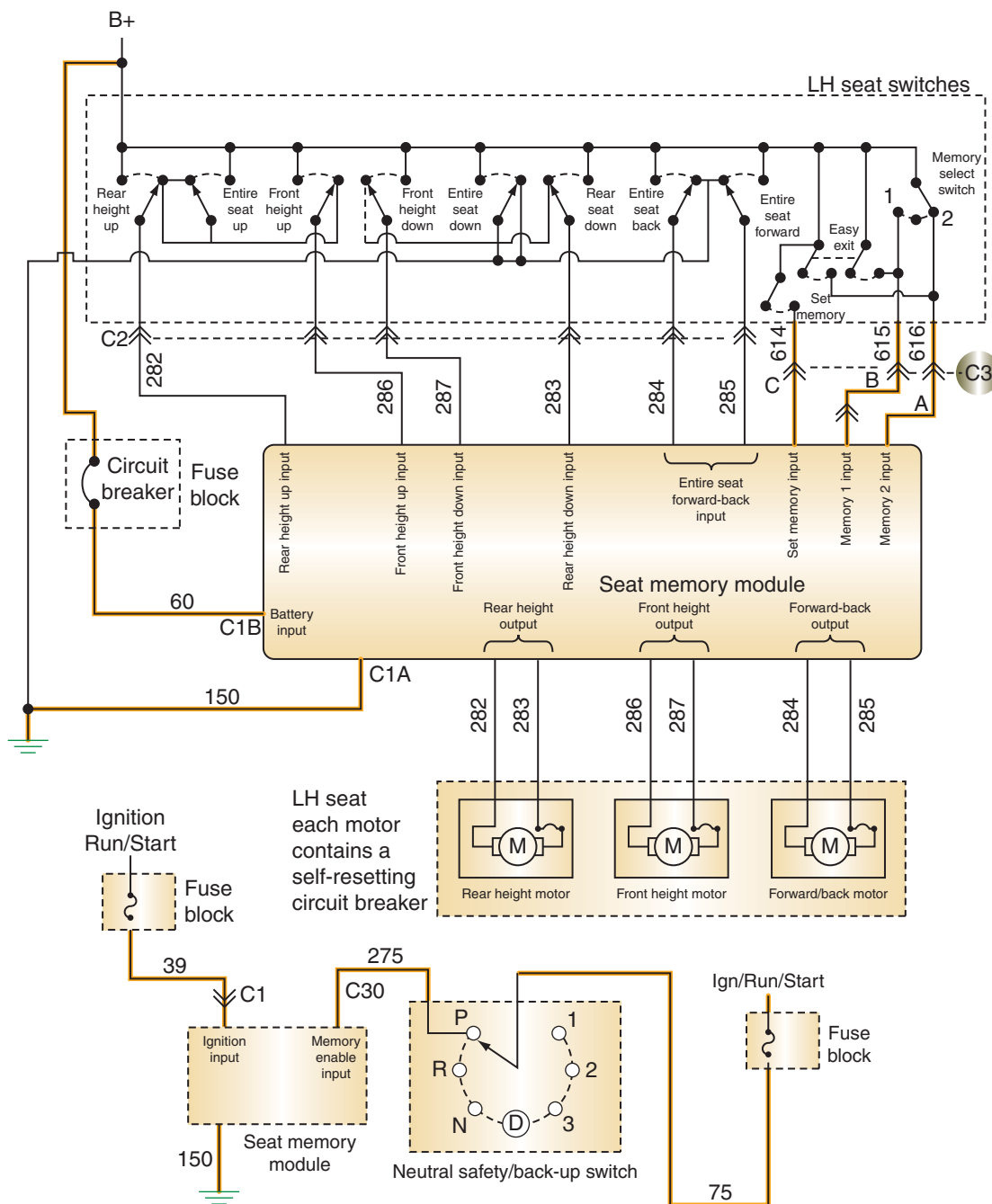


FIGURE 14-26 To diagnose the memory seat feature, a circuit schematic is required.



fails to illuminate, check the ground circuit for an open. Move the test light between circuit 39 and ground. The light should turn on. If not, there is an open in circuit 39.

Connect the test light between terminal D of connector C3 and ground. If the light does not turn on, there is a problem in the neutral safety switch circuit. Check the adjustment of the neutral safety switch and circuits 75 and 275 for opens. With the test light connected between terminal B of the C3 connector and ground, the test light should remain off. An illuminated light indicates the left-seat switch assembly must be replaced.

Leave the test light connected between terminal B of the C3 connector and ground. Place the memory select switch in position 1. If the test light does not illuminate, check circuit 615 for an open. If the wire is good, use an ohmmeter to test the memory select switch for an open. Release the memory select switch and press the EXIT button. The test light should light. If the light fails to illuminate, there is a fault in the left-seat switch assembly. It therefore must be replaced.

Move the probe of the test light to terminal A of the C3 connector and press the exit button. If the light fails to illuminate, the problem is in circuit 616 or in the exit switch. With the test light still connected to the A terminal of the C3 connector, release the EXIT button. The test light should turn off. If the test light remains illuminated, replace the left-seat switch assembly.

Continue to leave the test light connected to terminal A. Place the memory select switch in the number 2 position. The test light should light. If not, replace the left-seat switch assembly.

With the test light connected between C3 connector terminal C and ground and the memory select switch released, the test light should be off. If it remains on, the seat switch assembly is defective. Press the set memory switch. The test light should illuminate. If not, check the set memory switch and circuit 614 for an open.

If all the test results were correct, the fault is in the control module. The module must be replaced.

## POWER DOOR LOCK DIAGNOSIS

To test the door lock motor, apply 12 volts directly to the motor terminals. The actuator rod should complete its travel in less than 1 second. Reverse polarity to test operation in both directions.

The switch is checked for continuity using an ohmmeter. There should be no continuity between any terminals when the switch is in its neutral position. Use the circuit schematic to determine when there should be continuity between terminals.

If the system uses a relay, use the schematic to determine relay circuit operation. In this example, battery voltage should be present at terminal 4 of the connector. Using an ohmmeter, check the ground connects of terminals 1 and 5 of the connector. To test the relay, connect a test light across terminal 3 and ground. Ground terminal 1 and apply power to terminals 2 and 4. The test light will light if the relay is good.

## AUTOMATIC DOOR LOCK SYSTEM TROUBLESHOOTING

Some systems offer self-diagnostics through the body computer. The service manual will provide the steps required to enter diagnostics on these vehicles. The following is an example of locating the fault in vehicles that do not provide this feature when the door locks work but they do not lock or unlock automatically. As with any electrical diagnosing, you will need the circuit diagram for the system you are working on. The following steps relate to the system shown (Figure14-27):

1. Locate the controller and back probe for voltage at the power input terminal D with the ignition switch in the RUN position. If there is no voltage present, there is an open in circuit 39.
2. Back probe for voltage between terminals A and D. If there is no voltage, check for an open in circuit 150.
3. Make sure the courtesy lights are off and all doors are closed. With the gear selector in the PARK position, turn the ignition switch to the RUN position.
4. Connect a test light between controller terminal B and a good ground. If the neutral safety switch circuit is operating properly, the test light will light.

**Classroom  
Manual**

Chapter 14, page 394



### SPECIAL TOOLS

Jumper wires  
Ohmmeter  
Test light

**Classroom  
Manual**

Chapter 14, page 398



5. With the test light connected as in step 4, move the gear selector to any other position. The test light should go out. If the light does not go out, check the neutral safety switch. It may be out of adjustment or faulty.
6. Leave the gear selector as in step 5 and connect the test light between terminals C and D. The test light should not illuminate. If it does, check circuit 156 and the light switch and doorjamb switches.
7. Return the gear selector to the PARK position. Connect the test light between terminal H and ground.
8. Observe the test light while the gear selector is moved from PARK to REVERSE. The test light should flash once. If not, replace the controller.

If the circuits passed all tests, check circuits 207 and 195, and the left switch assembly for opens.

## REMOTE KEYLESS ENTRY DIAGNOSIS

Many new vehicles are equipped with a remote keyless entry system that is used to lock and unlock the doors, turn on the interior lights, and release the trunk latch. A small receiver is installed in the vehicle. The transmitter assembly is a hand-held item attached to the key ring (Figure 14-28). It has three buttons that control the functions of the system.

The system operates at a fixed radio frequency. If the unit does not work from a normal distance, check for two conditions: weak batteries in the remote transmitter or a strong radio transmitter close by (radio station, airport transmitter, etc.).

If the system has other problems, make sure the door locks, trunk latch, and interior lamps work normally when manually activated. If these systems check out fine, detailed diagnosis of the remote system is necessary. Follow the manufacturers' recommendations for doing this.

The transponder operation can be tested using an RF signal meter (Figure 14-29). By operating the transponder while the RF signal meter is on, the strength of the signal will be displayed by the LEDs. If the transponder fails to indicate a signal, test the transponder batteries. Usually two 3-volt batteries are used. Also be sure the batteries are installed correctly since they are polarity sensitive.



### SPECIAL TOOLS

DMM  
Scan tool  
Test light  
Service manual

### Classroom Manual

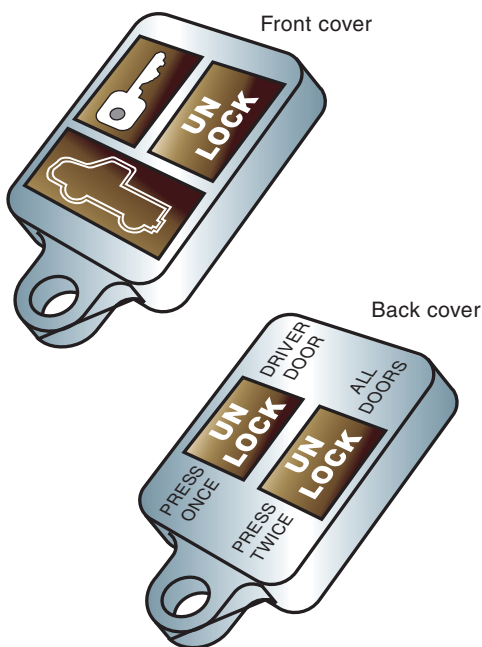
Chapter 14, page 401

This system is usually called by its acronym RKE, pronounced "Rickie."



### SPECIAL TOOLS

RF signal meter



© Delmar/Cengage Learning

FIGURE 14-28 Typical door lock control transmitter assembly.



© Delmar/Cengage Learning

FIGURE 14-29 RF signal meter indicates the strength of the signal.

## ANTITHEFT SYSTEM TROUBLESHOOTING

As with many electrical systems, manufacturers take many approaches in designing their anti-theft system. Most of the testing of relays, switches, and circuits require only basic electrical troubleshooting capabilities. Use the troubleshooting chart as a guide in locating the fault. Refer to the service manual for the correct procedure of arming the system you are diagnosing.

### Classroom Manual

Chapter 14, page 404



### SPECIAL TOOLS

Test light  
DMM  
Scan tool  
Service manual

This system is also referred to as “Vehicle Security System (VSS)” and “Vehicle Theft Security System (VTSS).”

## Self-Diagnostic Systems

Some antitheft systems offer self-diagnostic capabilities. Follow the service manual procedures for the proper method of entering diagnostics for the vehicle you are working on. The following is a typical example of entering diagnostics.

Some vehicle theft security systems enter the diagnostic mode when the ignition switch is cycled three times from the OFF to accessory position. When the vehicle theft security system is in the diagnostic mode, the horn should sound twice and the parklamps and taillamps should flash. If the horn does not sound or the lights do not flash, voltmeter and ohmmeter tests are required to locate the cause of the problem.

The scan tester may be used to diagnose many vehicle theft alarm systems. Follow the scan tester manufacturer’s recommended procedure to enter the vehicle theft alarm system diagnostic mode. When this diagnostic mode is entered, the horn may sound twice to indicate the trunk lock cylinder is in the proper position. When the key is placed in the ignition switch, the parklamps and taillamps should begin to flash.

The following procedures should cause the horn to sound once if the system is operating normally:

1. Activating the power door locks to the LOCKED and UNLOCKED positions.
2. Using the key to lock and unlock each front door.
3. Turning on the ignition switch.

When the ignition switch is turned on in procedure 3, the diagnostic mode is exited.

**CUSTOMER CARE:** Always check the indicator lights in a customer’s vehicle. These lights may be indicating a dangerous situation, but the customer may not have noticed them. For example, the vehicle theft security system set light may not be flashing when the normal system arming procedure is followed. This indicates an inoperative security system, and someone could break into the car without triggering the alarms. The customer has paid a considerable amount of money to have this system on the car. Therefore, it should be working. If this defect is brought to the customer’s attention, he will probably have you repair the system and will appreciate your interest in the vehicle.

## Alarm Sounds for No Apparent Reason

Mechanical and corrosion factors on the cylinder tamper switches can cause the system to activate for no apparent reason. If the customer complains of this condition, check the lock cylinder for looseness. Any looseness of the cylinder can cause the switch to activate the alarm.

Other causes of alarm system activation include loose, corroded, or improperly adjusted jamb switches. The switches should be adjusted to assure they remain in the OFF position when the doors are fully closed. The switch is adjusted by a nut located at the base of the switch.

## Controller Test

To test the controller used in the illustration (Figure 14-30), disconnect the harness from the controller and the harness to the relay. Connect the test light between the N terminal and ground. The test light should illuminate to indicate voltage to the horns and controller.



### CAUTION:

Failure to disconnect both harnesses will lead to false test indications.

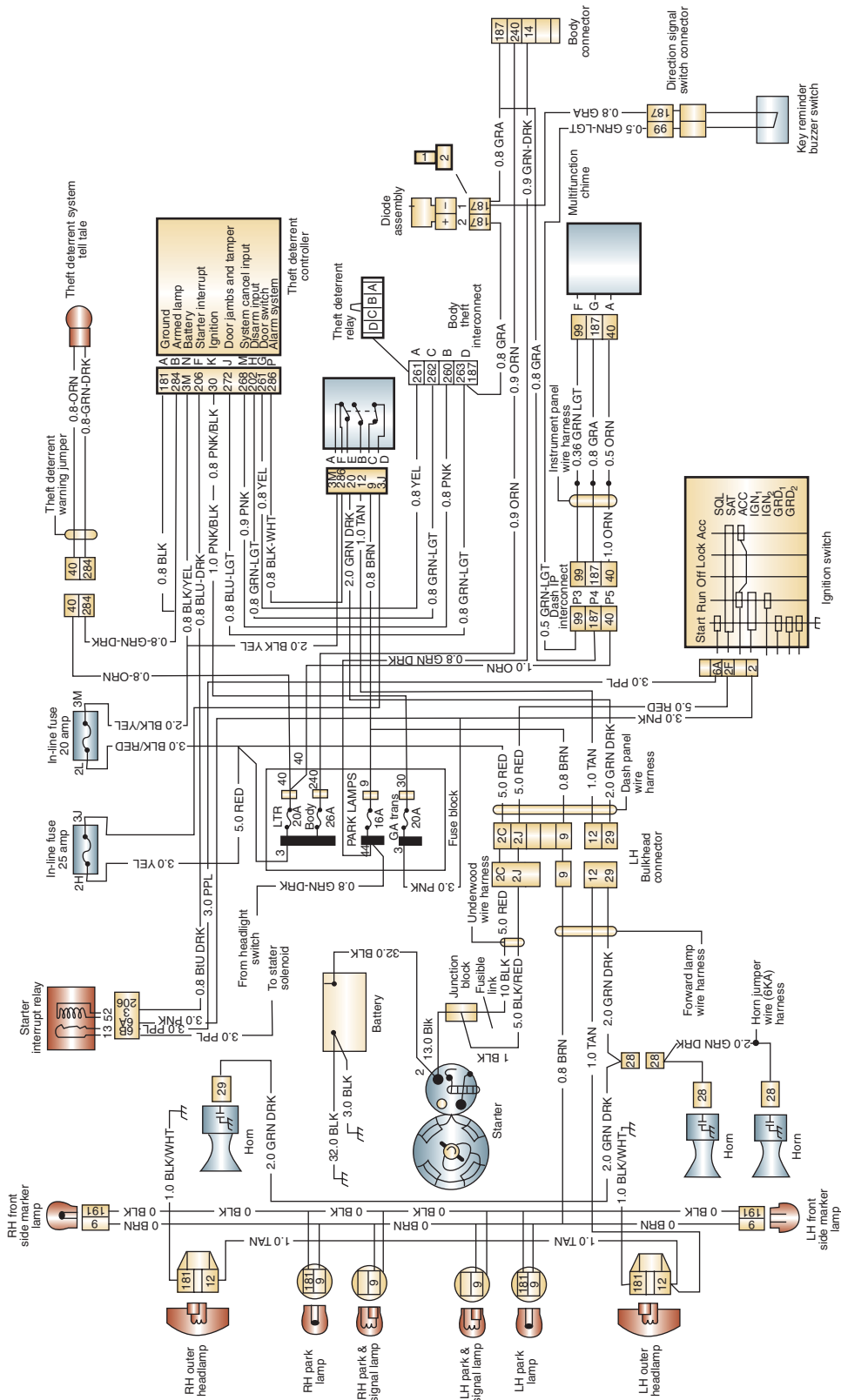


FIGURE 14-30 Circuit schematic of anti-theft system.

© Delmar/Cengage Learning



Move the test light probe to terminal M. The light should turn on only when the electrical door lock switch is moved to the UNLOCK position. Next, connect the test light between terminal B and a 12-volt source. The light should light only if the doors are locked. The light should go out if any doors are unlocked.

Probe terminal K for voltage. The test light should illuminate only when the ignition switch is placed in the RUN position. Check for a blown fuse or an open circuit if it does not light.

To test whether the cylinders are operating properly and have not been tampered with, connect the test light between terminal J and a 12-volt source. The test light should light only if a door is open. If it glows with the doors closed, inspect the lock cylinders for damage.

With the test light connected between terminal H and a 12-volt source, the test light should be on only when the outside door key is turned to the unlock position. Move the test light between terminal G and a good ground. The light should illuminate when the electric door lock switch is operated. This indicates there is electrical power to the switch. The test light should light in the LOCK position and go out in the UNLOCK position.

Reconnect the relay harness. When the test light is connected between the F terminal of the controller connector and ground, the horn should sound and the lights should turn on. This indicates that the relay coil is functioning.

Next, turn the ignition switch to the RUN position with the test light connected between the E terminal of the controller connector and ground. Use a voltmeter to measure voltage to the starter. There should be zero volts. This indicates the starter interrupt relay is opening to prevent engine starting.

Connect a jumper wire between terminal D and a good ground while observing the security warning light. The warning light should be on. Connect a test light between terminal A of the controller connector and a 12-volt power supply. The test light should light. If not, there is a problem in the ground circuit.



### SERVICE TIP:

In some instances, it may be easier to attempt starting the engine than to check for voltage at the starter. If the relay is working properly, the engine will not start.



### SPECIAL TOOLS

Jumper wires  
Service manual

### Classroom Manual

Chapter 14, page 407



### SPECIAL TOOLS

Scan tool  
DMM

## Relay Test

Faulty relays are a leading cause of antitheft system malfunction. Testing the relay is a simple matter of using a jumper wire to bypass the relay. If the circuits operate with the relay bypassed, but not with the relay connected, the relay is probably at fault. However, do not replace the relay until you have tested for the proper amount of applied voltage to the relay and for proper ground switching of the controller. Follow Photo Sequence 27 as a guide for relay testing.

## IMMOBILIZER SYSTEM SERVICE

A common service to the immobilizer system is the addition of keys. Usually the system can record several different key codes. However, the manufacturer may only provide two keys at the time of vehicle purchase. If additional keys are purchased, they will require programming into the system prior to use. Most manufacturers provide a method the customer can follow to program their new keys. This option is not available on all systems. Canadian systems do not allow for customer programming of keys. The following is one method that is used for customer programming of the keys.

In order to perform the customer-programming method, two valid keys must be used to enter the programming routine. The immobilizer module needs to see two unique key IDs before it will allow programming. One key cannot be used two times. Also, the key that is being programmed to the vehicle must be a blank key. If it has been programmed to another vehicle, it cannot be programmed again. If the sequence is not followed, the immobilizer will abort the programming process.

The customer-programming method is as follows:

1. Insert one of the two valid Sentry Keys into the ignition switch and turn the ignition switch to the RUN position. Leave the ignition switch in the RUN position for at least 3 seconds, but not more than 15 seconds.



## TYPICAL PROCEDURE FOR TESTING THE ANTITHEFT RELAY

All photos in this sequence are © Delmar/Cengage Learning.



**P27-1** The tools required to perform this task are a set of jumper wires and the proper service manual.



**P27-2** Disconnect the relay wiring harness.



**P27-3** Connect the jumper wire between terminals A and B. The horns should sound.



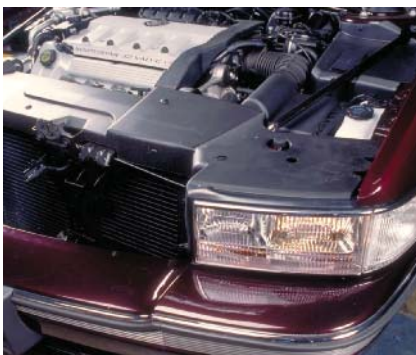
**P27-4** Move the jumper wire to connect terminals D and C.



**P27-5** The park, tail, and side marker lights should illuminate.



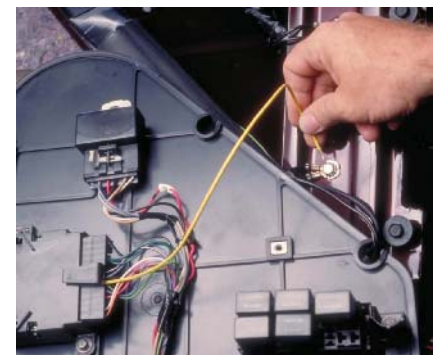
**P27-6** Connect the jumper wire between terminals D and E.



**P27-7** The low beam lights should turn on.



**P27-8** Reconnect the relay harness.



**P27-9** Connect the jumper wire from terminal F to a good ground.

### TYPICAL PROCEDURE FOR TESTING THE ANTITHEFT RELAY



**P27-10** Listen for the relay to click.  
Then the light and horn circuits  
should be activated.

2. Cycle the ignition switch to the OFF position and remove it.
3. Within 15 seconds, insert the second valid Sentry Key into the ignition switch and turn the ignition switch to the RUN position. Leave the ignition switch in the RUN position while observing the immobilizer warning lamp.
4. In about 10 seconds after the completion of step 3, the security indicator in the instrument cluster will start to flash and a single chime will sound. This indicates that the immobilizer system is in programming mode.
5. Within 60 seconds, turn the ignition switch to the OFF position and remove the key.
6. Insert the blank key into the ignition switch and turn the ignition switch to the RUN position.
7. In about 10 seconds, an audible chime will sound and the security indicator will stay illuminated solid for 3 seconds then turn off. This indicates that the new key has been successfully programmed.
8. Cycle the ignition switch to the OFF position before attempting to start the engine.

If additional keys are to be programmed, the entire procedure must be performed for each key. The system automatically exits programming mode after a blank key is programmed.

If the vehicle owner lost a key and needs to program a new one, he may not be able to do so unless he still has two valid keys. In this case, the technician will need to use the secure method of programming the new key. This method requires the use of a diagnostic scan tool. Also, a unique PIN code that is programmed into the immobilizer module will need to be obtained. This is a secure code that will need to be obtained from the vehicle owner, from the original vehicle invoice, or from the vehicle manufacturer.

Problems with the immobilizer system can result in engine no-start conditions. Since the system uses many hardwired components and circuits, these can be diagnosed and tested using normal diagnostic tools and procedures. However, to reliably diagnose the electronic message inputs used to provide the electronic features of the immobilizer system requires the use of a diagnostic scan tool.

If the diagnostics leads to replacement of the immobilizer module or the PCM, specific procedures may need to be followed. Usually the replacement module will require initialization. This will require the use of a scan tool and access to the PIN. This process will transfer the required data between modules so the system will be operative and the existing keys can still be used. After the initialization procedure is performed, the keys may need to be

programmed to the new immobilizer module. However, since the secret code data matches, the same keys can be reused.

## DIAGNOSIS AND SERVICE OF ELECTRONIC CRUISE CONTROL SYSTEMS

The cruise control system is one of the most popular electronic accessories installed on today's vehicles. During open-road driving, it will maintain a constant vehicle speed without the continued effort of the driver. This reduces driver fatigue and increases fuel economy.

Problems with the system can vary from no operation, to intermittent operation, to not disengaging. To diagnose these system complaints, today's technicians must be able to rely on their knowledge and diagnostic capabilities. Most of the system is tested using familiar diagnostic procedures. Build on this knowledge and ability to diagnose cruise control problems. Use system schematics, troubleshooting diagnostics, and switch continuity charts to assist in isolating the cause of the fault.

### Classroom Manual

Chapter 14, page 409

Cruise control systems are also called speed control by some manufacturers.



**WARNING:** When servicing and testing the cruise control system, you will be working close to the air bag and the antilock brake systems. The service manual will instruct you when to disarm and/or depressurize these systems. Failure to follow these procedures can result in injury and additional costly repairs to the vehicle.

## Self-Diagnostics

Most vehicle manufacturers have incorporated self-diagnostics into their cruise control systems. This allows some means of retrieving trouble codes to assist the technician in locating system faults. Modern vehicles usually require the use of a scan tool to retrieve the DTCs and to perform diagnostic tests of the cruise control system. The following examples illustrate how DTCs are retrieved and diagnosis perform on some earlier electronic systems.

On any vehicle, perform a visual inspection of the system. Check the vacuum hoses for disconnects, pinches, loose connections, and so forth. Inspect all wiring for tight, clean connections. Also, look for good insulation and proper wire routing. Check the fuses for opens and replace as needed. Check and adjust linkage cables or chains, if needed. Some manufacturers will require additional preliminary checks before entering diagnostics. In addition, perform a road test (or simulated road test) in compliance with the service manual to confirm the complaint.

**General Motors.** General Motors has used several different types of electronic cruise control systems. The common procedure for performing self-diagnostics and retrieving codes for system types 1, 3, and 4 follows. Refer to the service manual to determine which system applies to the vehicle you are working on. Type 2 systems do not provide fault code retrieval.

**Type 1 Diagnostics.** Brougham models with a type 1 system do not provide for trouble code retrieval. Instead a special tool called a "Quick Checker" is used to test the system. To enter self-diagnostics on other vehicles equipped with this system, place the ignition switch in the RUN position and press the OFF and WARMER buttons on the climate control panel (CCP) simultaneously. All of the panel segments should light. If not, the affected panel must be replaced before continuing.

All PCM trouble codes will be displayed, followed by all BCM codes. Engine controller codes are prefixed with an "E" and BCM codes are prefixed with an "F." On Eldorado and



### SPECIAL TOOLS

Quick checker



Seville models, “Current” or “History” will accompany the codes. On DeVille and Fleetwood models, trouble codes that are displayed on the first pass but not on the second represent history codes. History codes are intermittent faults that have occurred in the past but are not present in the most recent self-test.



## SPECIAL TOOLS

Scan tool

**Type 3 Diagnostics.** Code accessing can be done through the use of a scanner, flashing the “Service Engine Soon” light, or through the ECC panel. The method used depends on the model of vehicle being serviced.

To flash the service light, ground terminal B of the data link connector with the ignition switch in the RUN position. Any stored memory codes will be flashed by the light. Also, all PCM-controlled relays and solenoids will be energized.

The indicator light will flash a code 12 (one flash followed by two more flashes) to indicate the system is operating properly. If there are any trouble codes, they are each displayed three times. At the end of the trouble codes, a code 12 will be flashed to indicate code resequencing has begun. If a scan tool is used to retrieve the codes, connect it to the DLC and follow the instructions to retrieve the codes.

Toronado, Reatta, and Riviera models provide for diagnostics through the ECC or CRT panel. Trouble codes are accessed by placing the ignition switch in the RUN position, then pressing the OFF and WARMER buttons on the ECC/CRT panel at the same time. On models equipped with CRT displays, depress the OFF hardkey and the WARM softkey. On Reatta and Riviera models, the WARM button is identified as TEMP-UP.

All ECM trouble codes will be displayed, followed by all BCM codes. On Eldorado and Seville models, “Current” or “History” will accompany the codes. On DeVille and Fleetwood models, trouble codes displayed on the first pass but not on the second, represent history codes.

After the diagnostic service mode is selected, any trouble codes in memory will be displayed. Engine controller codes are prefixed with an “E,” BCM codes are prefixed with a “B,” instrument panel cluster (IPC) codes are prefixed with an “I,” and supplemental restraint system (SRS) codes are prefixed with an “R.”

**Type 4 Diagnostics.** Use the chart (Figure 14-31) to determine the type of code to read for the symptom. If it instructs you to read a type A code, refer to the other chart (Figure 14-32) and follow this procedure:



**WARNING:** The number 4 code is checked with the drive wheels lifted from the floor and the engine idling.

1. Turn the ignition switch to the RUN position.
2. Turn the SET/COAST switch on.
3. Push the main switch on.
4. Turn the SET/COAST switch off.
5. Perform the condition requirements listed in the chart.

The diagnostic code is read on the main switch indicator by counting the flashes.

If instructed to read type B codes, refer to the proper chart (Figure 14-33) and follow this procedure:

1. Road test the vehicle.
2. If the system cancels because of a malfunction in the actuator or speed sensor, the indicator light will blink 5 times. If this occurs, do not turn off the ignition switch or the control switch. Inspect the system with the switches on. Turning off the switches will erase the codes from memory.

Observed Symptom	Code Type	Results	Components To Be Diagnosed
<ul style="list-style-type: none"> <li>Cruise control switch indicator blinks five times or</li> <li>Cruise control does not set or</li> <li>Cruise control inoperative.</li> </ul>	Type B	11	<ul style="list-style-type: none"> <li>Actuator</li> <li>Module</li> </ul>
		21	<ul style="list-style-type: none"> <li>Speed Sensor</li> <li>Module</li> </ul>
		23	<ul style="list-style-type: none"> <li>Speedometer</li> <li>Actuator</li> <li>Speed Sensor</li> <li>Vacuum Supply</li> <li>Vacuum Switch</li> <li>Module</li> </ul>
		31	<ul style="list-style-type: none"> <li>Engage Switch</li> <li>Module</li> </ul>
		33	<ul style="list-style-type: none"> <li>Engage Switch</li> <li>Module</li> </ul>
	Type A Code 5	No Code	<ul style="list-style-type: none"> <li>Speed Sensor</li> <li>Module</li> </ul>
		OK	<ul style="list-style-type: none"> <li>Cruise Control Switch</li> <li>Engage Switch</li> <li>Stoplamp Switch</li> <li>Clutch or Neutral Start Switch</li> <li>Parking Brake Switch</li> <li>Speedometer</li> <li>Actuator</li> <li>Module</li> <li>Vacuum Hose</li> </ul>
Set speed deviated.	Type A Code 3	OK	<ul style="list-style-type: none"> <li>Speedometer</li> <li>Speed Sensor</li> <li>Vacuum Supply</li> <li>Vacuum Switch</li> <li>Actuator</li> <li>Cruise Control Module</li> </ul>
		No Code	<ul style="list-style-type: none"> <li>Speed Sensor</li> </ul>
Vehicle speed fluctuates when "SET/COAST" switch is activated.			<ul style="list-style-type: none"> <li>Speed Sensor</li> <li>Speedometer</li> <li>Actuator</li> <li>Module</li> </ul>
Set speed does not cancel when the brake is applied.	Type A Code 4	OK	<ul style="list-style-type: none"> <li>Actuator</li> <li>Stoplamp Switch</li> <li>Module</li> </ul>
		No Code	<ul style="list-style-type: none"> <li>Stoplamp Switch</li> <li>Module</li> </ul>
Set speed does not cancel when the parking brake is applied.	Type A Code 4	OK	<ul style="list-style-type: none"> <li>Actuator</li> <li>Module</li> </ul>
		No Code	<ul style="list-style-type: none"> <li>Parking Brake Switch</li> <li>Module</li> </ul>

FIGURE 14-31 Example of a General Motors Type 4 troubleshooting chart.

© Delmar/Cengage Learning

- While driving at a speed less than 10 mph, press the SET/COAST button three times within two seconds. Any codes will be displayed through the indicator light.

If no codes are displayed, refer to the service manual to perform diagnostic tests.

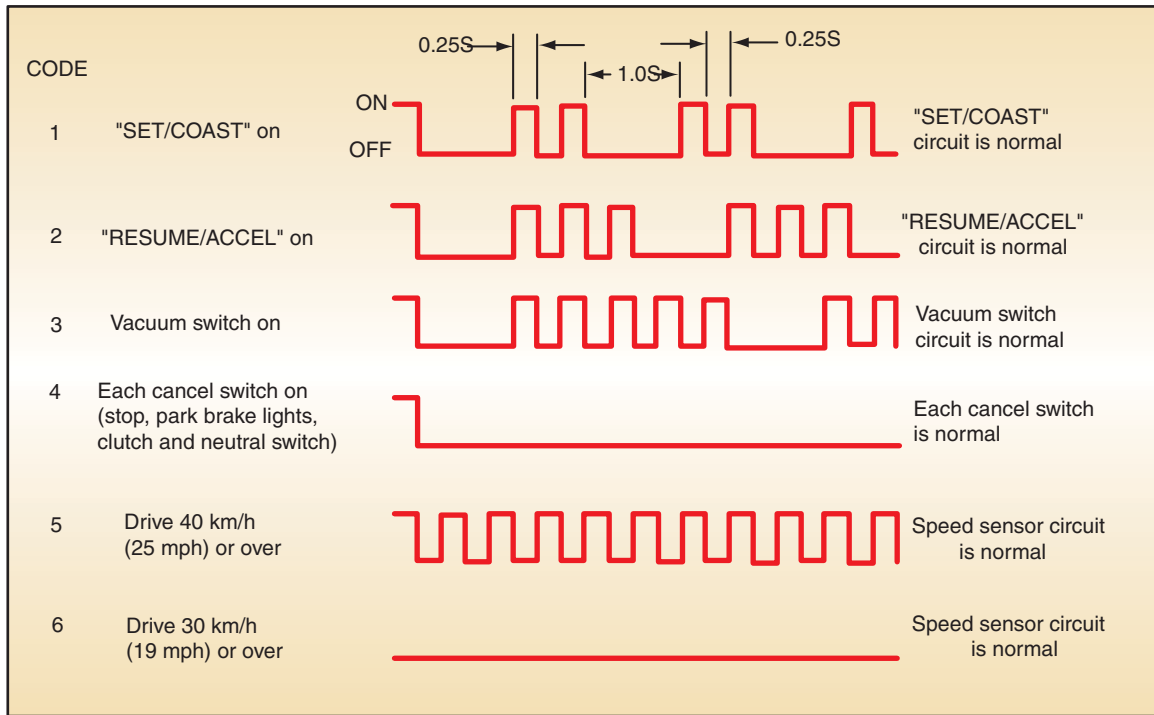


FIGURE 14-32 Type A code chart.

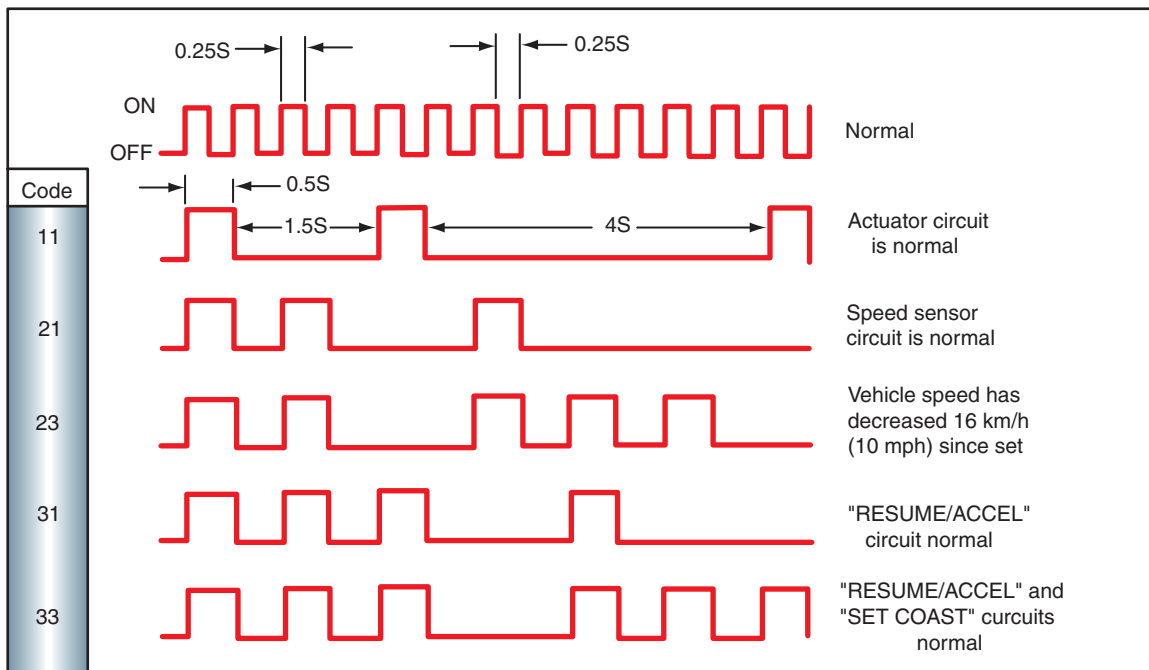


FIGURE 14-33 Type B code chart.



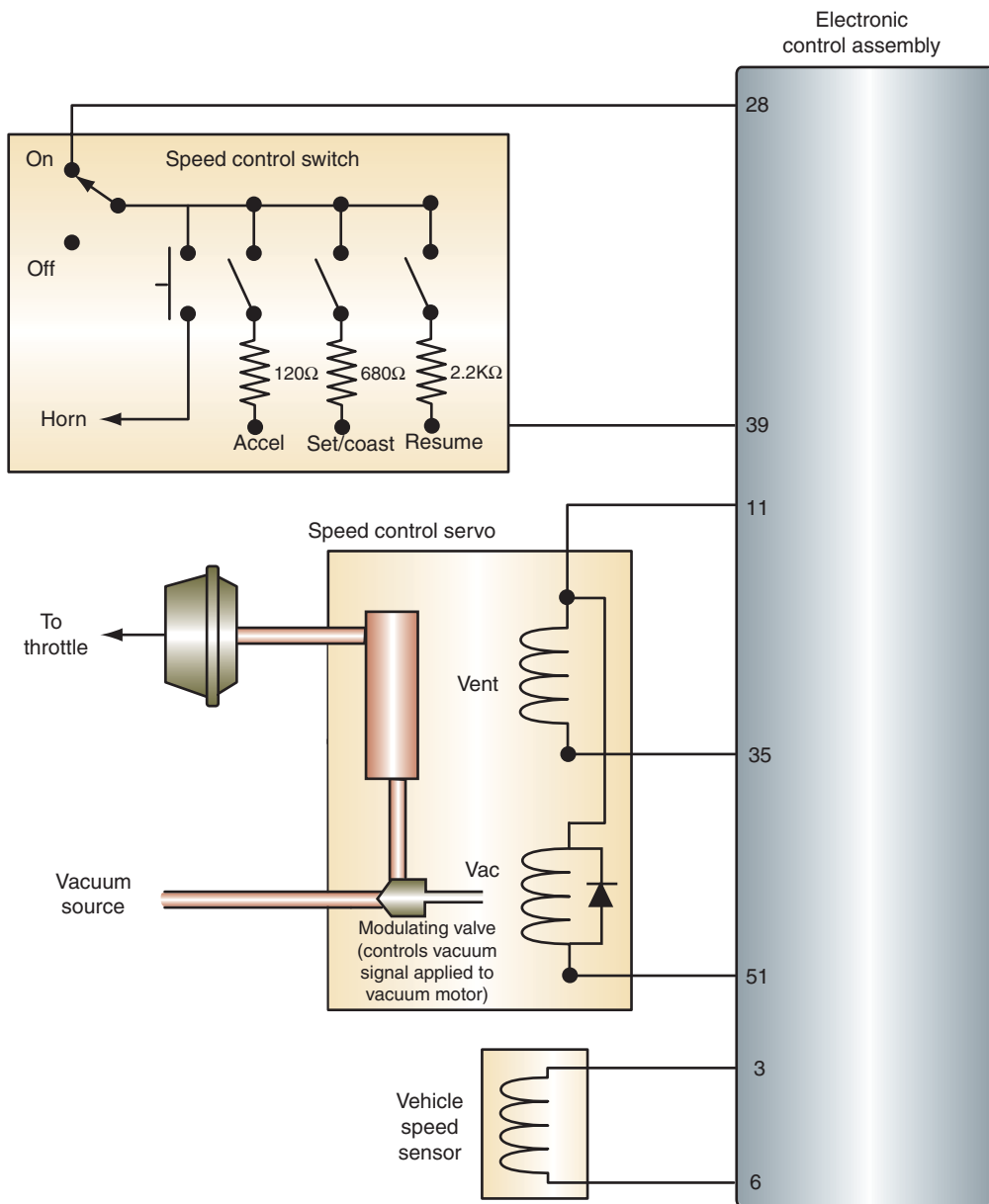
### SPECIAL TOOLS

- Scan tool
- Analog voltmeter
- Jumper wires
- Fender covers
- Service information

**Ford IVSC System Diagnostics.** Ford's integrated vehicle speed control (IVSC) system has self-test capabilities that are contained within the **KOEO** and **KOER** routine of the ECA (Figure 14-34). **KOEO** stands for Key On, Engine Off. It is a static test of the IVSC inputs and outputs. **KOER** stands for Key On, Engine Running. It is a dynamic check of the engine in operation. Testing of the IVSC system is broken down into two divisions: quick tests and pinpoint test.

The quick test will check the operation and function of all system components except the vehicle speed sensor. The quick test is performed first. Then, if any failure codes are displayed, the





**FIGURE 14-34** The IVSC system is an integrated system where the functions of the amplifier are included into the ECA.

**pinpoint test** is performed. This is a specific component test service. If there is a complaint with the cruise control system, and the quick test does not indicate any faults, test the speed sensor.

The processor stores the self-test program within its memory. When this test is activated, the processor initiates a function test of the IVSC system to verify that the sensors and actuators are connected and operating properly. The quick test will detect faults that are present at the time of the test. It will not store history codes.

The quick test can be performed with a scan tool or an analog voltmeter. To use an analog voltmeter, place the ignition switch in the OFF position. Connect a jumper wire from the **self-test input (STI)** terminal to pin 2 (single return) of the self-test connector (Figure 14-35). Set the analog voltmeter on the DC 15-volt scale. Then connect the positive voltmeter lead to battery positive and the negative lead to pin 4 (self-test output) of the self-test connector.

Follow the troubleshooting procedures in the service manual. Perform the KOEO, KOER, and intermittent (wiggle) test procedures.

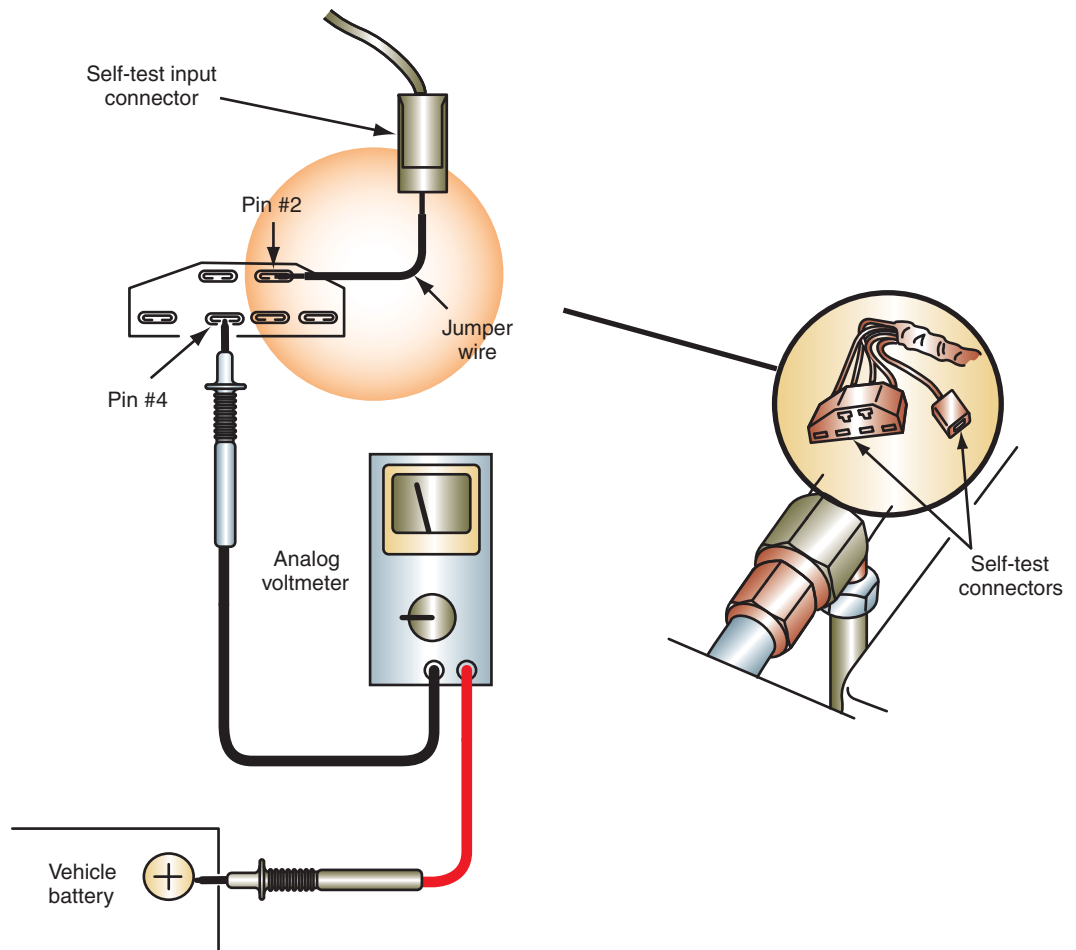


FIGURE 14-35 Voltmeter connections to the self-test connector and STI.

© Delmar/Cengage Learning

After the system has been serviced, perform the quick test to verify proper operation.



### SPECIAL TOOLS

Scan tool

**Chrysler.** Chrysler also uses several different types of electronic cruise control systems. The type 3 system does not provide trouble code diagnostics.

**Type 1 and 4 Diagnostics.** These cruise control types use the PCM to control the system. Trouble codes can be retrieved using a scan tool or by reading the flashes from the “Check Engine” light.

If a scan tool is not available, trouble codes can be retrieved through the “Check Engine” light by cycling the ignition from OFF to RUN three times within 5 seconds.

If fault code 34 is displayed, perform the speed control system test located in the service manual. This series of tests will check the electrical condition of the system, including switches and the servo.



**WARNING:** Before conducting the system test, disarm the air bag system as described in the service manual. Failure to disarm the air bag may result in deployment and personal injury. After all service is complete, rearm the air bag according to the service manual procedures.

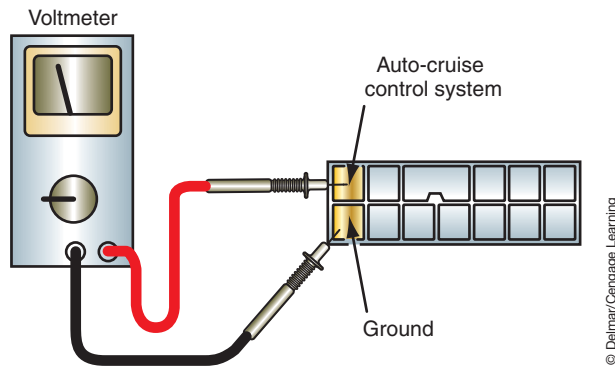
If the indicator light flashes a code 15, the distance sensor needs to be tested. A code 77 indicates that a speed control relay test must be performed.

**Type 2 Diagnostics.** This cruise control type is found on Chrysler vehicles that are produced by Mitsubishi Motors. This system uses a separate cruise control module. There are up to six trouble codes that can be displayed. One of these codes indicates normal operation.








### SPECIAL TOOLS

Analog voltmeter



**FIGURE 14-36** Connect the voltmeter between the two identified terminals.

© Delmar/Cengage Learning

Code number	Display patterns (output codes) (Use an analog voltmeter)	Probable cause	Check chart number
1		Vacuum pump assembly drive output system out of order	5
2		Vehicle speed signal system out of order	4
3		Control switch out of order (When "SET" or "RESUME" switch are kept ON state continuously for more than 60 seconds)	2
4		Control unit out of order	—
5		Throttle position sensor or idle switch out of order	9

**FIGURE 14-37** Trouble code display pattern chart.

© Delmar/Cengage Learning

To access the codes, connect a voltmeter between the ground and auto-cruise control terminals of the diagnostic connector (Figure 14-36). The connector is located on the lower left side of the instrument panel. With the ignition switch located in the RUN position, read the needle sweeps to determine the code. Once the code is determined, refer to the diagnostic display pattern chart for the vehicle being diagnosed (Figure 14-37). This chart will refer you to the correct check chart to locate the fault.

### Diagnosing Systems without Trouble Codes

Systems that do not provide for trouble code diagnostics require the technician to perform a series of diagnostic tests. The test performed will depend on the symptom. The following sections discuss areas of generic troubleshooting procedures for all types of systems.

**Simulated Road Test.** The simulated road test will allow the technician to perform a road test without leaving the shop. Before performing this test, connect the shop's ventilation system to the vehicle's exhaust pipe. Lift the drive wheels from the floor and place jack stands under the vehicle. If the vehicle is equipped with CV joint shafts, place the jack stands under the lower control arms so the shafts are in their normal drive position. If the vehicle is rear-wheel drive with a solid axle, place the jack stands under the axle.



**CAUTION:**  
The same trouble code between models and years of manufacture may have different diagnostic charts.

**Classroom Manual**  
Chapter 14, page 412



### CAUTION:

During this test, it is possible the engine will overspeed. If the system should appear to go out of control, the technician must be ready to turn it off. This can be done by turning off the ignition or turning off the speed control switch.



### CAUTION:

Do not exceed 50 mph or damage to the differential assembly may result.



### CAUTION:

Do not attempt to place the transmission back into PARK at any time during the test without first stopping the drive wheels with the brakes. Doing so may result in damage to the transmission.



### SPECIAL TOOLS

DMM  
Vacuum pump



**WARNING:** Block the wheels that are to remain on the ground. The wheels must remain blocked throughout the test.

Start the engine and place the transmission into drive. Turn the speed control switch into the ON position. Accelerate and hold the speed at 35 mph (56 kmh). Press and release the SET ACCEL button. Maintain a slight foot pressure on the accelerator. The speed should be maintained at 35 mph (56 kmh) for a short period of time, then gradually start to surge. The engine surge is caused by operating the system while there is no load on the engine and is normal.

Press the OFF button and the engine should decelerate to an idle speed. Stop the drive wheels by lightly applying the brakes. Press the ON button and accelerate to 35 mph (56 kmh). Press and hold the SET/ACCEL button and gradually remove your foot from the accelerator pedal. The engine rpm should begin to increase. Continue to hold the SET ACCEL button until the indicated speed reaches 50 mph (80.4 kmh); then release the button. Vehicle speed should remain at 50 mph (80.4 kmh) for a short period of time; then the engine will start to surge.

Press the COAST button and hold it. The engine rpm should return to idle speed. Allow the indicated speed to slow to 35 mph (56 kmh) without applying the brakes. When the speed is returned to 35 mph (56 kmh), release the COAST button. The speed should be held at 35 mph (56 kmh) for a short period of time; then the engine will begin to surge.

Tap the brake pedal, which will cause the speed control system to shut off and engine speed to return to idle. Set the indicated speed to 50 mph (80.4 kmh); then use the brakes to slow to 35 mph (56 kmh). Maintain 35 mph (56 kmh) using the accelerator. Depress the RESUME button and the speed should climb to 50 mph (80.4 kmh).

## Diagnosing No Operation

The first step in a verified no-operation complaint is to check all fuses. Next, visually inspect the system for any obvious problems. If the visual inspection does not pinpoint the problem, perform the following steps:

1. Apply the brake pedal to observe proper brake light operation. If the brake lights do not operate, check the switch and circuit. Some brake switches have multiple internal switches; for example, one contact can be used for the brake lights, another contact used as an input to the PCM or TCM, and a third for the cruise control servo circuit. On these systems, just because the brake lights come on does not mean the brake switch is good. Use a scan tool to monitor the different brake switch inputs to confirm proper operation.
2. If the vehicle is equipped with a manual transmission, check to assure that the clutch deactivator switch is operating properly. Use an ohmmeter or voltmeter to test its operation.
3. Check for proper operation of the actuator lever and throttle linkage.
4. Disconnect the vacuum hose between the check valve and the servo (on the servo side of the check valve). Apply 18 inches of vacuum to the open end of the hose to test the check valve. It should hold the vacuum. If not, replace the check valve.
5. Check the vacuum dump valve for proper operation.
6. Test control switches and circuits following the procedure already learned. Use the circuit diagram and switch continuity charts to aid in testing.
7. Test servo operation.
8. Test speed sensor operation.
9. If all tests indicate proper operation, yet the system is not operational, replace the amplifier (controller).

## Diagnosing Continuously Changing Speeds

If the vehicle speed changes up and down while the cruise control is on, use the following steps to locate the problem:

1. Check the actuator linkage for smooth operation.
2. Check the speedometer for proper routing and to make sure there are no kinks in the cable.
3. Test the servo.
4. Check the speed sensor.
5. Check the operation of the vacuum dump valve.
6. Check all electrical connections.
7. If none of these tests locate the fault, replace the amplifier (controller).

## Diagnosing Intermittent Operation

Intermittent operation is usually caused by loose electrical or vacuum connections. If a visual inspection fails to locate the fault, test drive the vehicle and identify when the intermittent problem occurs. If the problem occurs during normal cruising, begin at step 1. If the problem occurs when operating the control buttons, or when the steering wheel is rotated, begin with step 3.

1. Connect the vacuum gauge to the hose entering the servo. There should be at least 2.5 in. Hg (8.5 kPa) of vacuum.
2. Test the servo assembly.
3. Use the service manual's switch continuity chart and system schematic to test switch operation. Turn the steering wheel through its full range while testing the switches. For example, using the Ford system shown (Figure 14-38), this test would be conducted by disconnecting the connector at the amplifier and connecting an ohmmeter between the terminal for circuit 151 and ground (with the ignition switch off). While rotating the steering wheel throughout its full range, make the following checks:
  - Depress the OFF button; the ohmmeter reading should read between zero and 1 ohm.
  - Depress the SET/ACCEL button and check for a reading between 646 and 714 ohms.
  - Depress the COAST button and the ohmmeter should read between 126 and 114 ohms.
  - When the RESUME button is depressed, the reading should be between 2,310 and 2,090 ohms.

If the resistance values fluctuate while the steering wheel is being turned, the most likely cause is contamination on the slip rings or faulty clock spring. If the resistance values are above specifications, check the switches and ground circuit.

If the preceding tests (or the road test) fail to identify the fault, conduct a simulated road test while wiggling the electrical and vacuum connections. Monitor the brake switch input with a scan tool. A misadjusted or faulty brake switch can cause the system to shut off if it thinks the brakes are being applied.

## Component Testing

Testing of the safety switches and circuits is performed using normal testing procedures you have already learned. Testing of the servo assembly, dump valve, and speed sensor is included to familiarize you with these procedures.

**Servo Assembly.** Actuator tests vary depending on design. Some manufacturers use vacuum servos and others use stepper motors. Be sure to follow the service manual procedures for the vehicle you are diagnosing. The servo controls the position of the throttle by receiving a controlled amount of vacuum. The following servo assembly test is a common test for Ford's cruise control system. Use the schematic (Figure 14-38) to perform the following test.

Disconnect the eight-pin connector to the amplifier. Connect an ohmmeter between circuits 144 and 145. The resistance value should be between 40 and 125 ohms. Move the lead



### SPECIAL TOOLS

Vacuum Gauge  
Ohmmeter

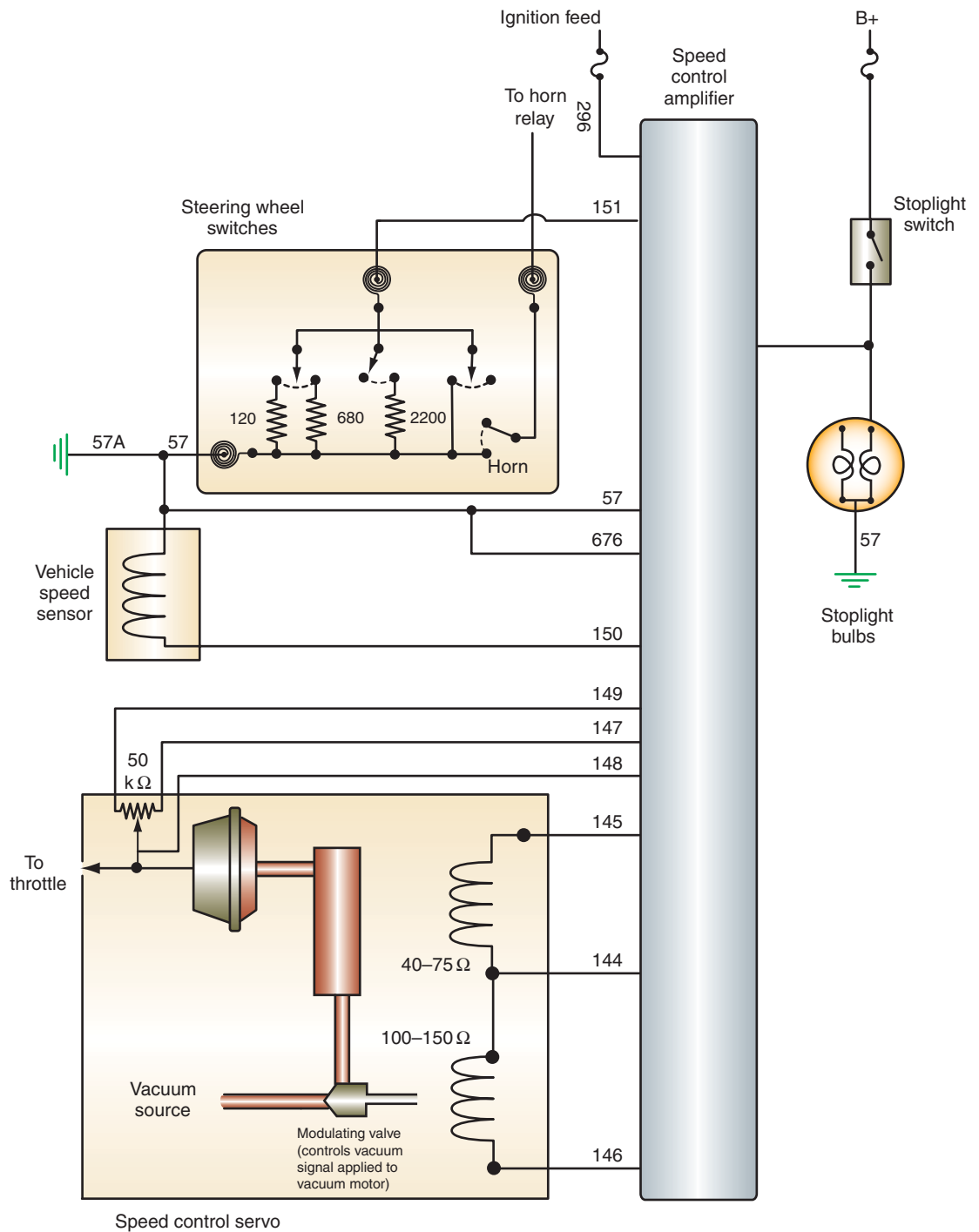
### Classroom Manual

Chapter 14, page 410



### SPECIAL TOOLS

DMM  
Jumper wires



**FIGURE 14-38** Speed control electrical schematic.



**CAUTION:**

Be ready to abort the test by turning off the ignition, if engine rpm should rise to a level where internal damage may result.



**WARNING:** Be sure to have the transmission in PARK or NEUTRAL. Block the wheels and set the parking brake before performing the servo test.

from circuit 145 to circuit 146. The resistance value should read between 60 and 190 ohms. If the resistance levels are out of specifications, check and repair the wiring between the amplifier and the servo. If the wiring is good, replace the servo.

If the resistance values are within specifications, leave the amplifier disconnected and start the engine. Jump 12 volts to circuit 144 and jump circuit 146 to ground. Momentarily jump circuit 145 to ground. The servo actuator arm should pull in and the engine speed should increase.



Remove the jumper to ground on circuit 146. The servo should release, and engine speed should return to idle. The servo must be replaced if it does not operate as described.

**Dump Valve.** The **dump valve** is a safety switch that releases vacuum to the servo when the brake pedal is pressed. A dump valve that is stuck open or leaks will cause a no-operation or erratic-operation complaint. Failure of the dump valve not to release vacuum may not, by itself, be noticed by the driver. It is part of a fail-safe system. If the dump valve does not release, the electrical switch signal is also used to disengage the cruise control system when the brakes are applied. It is good practice to test the dump valve any time the vehicle is in the shop for cruise control service.

To test the dump valve, disconnect the vacuum hose from the servo assembly to the dump valve. Connect a hand vacuum pump to the hose and apply vacuum to the dump valve. If vacuum cannot be applied, either the hose or the dump valve is defective.

If the valve holds vacuum, press the brake pedal. The vacuum should be released. If not, adjust the dump valve according to the service manual procedures. If the dump valve fails to release vacuum when the brake is applied and it is properly adjusted, it must be replaced.

**Speed Sensor.** Disconnect the six pin connector from the amplifier (Figure 14-28). Connect an ohmmeter between circuits 150 and 57A. The resistance should be approximately 200 ohms. If the resistance value is less than 200 ohms, check for a short in the circuits between the amplifier and the speed sensor. If there is no problem in the wiring, the coil in the sensor is shorted.

If the resistance value is infinite, there is an open in the wires or in the sensor coil.

To test the sensor separate of the wiring harness, disconnect the wire connector from the sensor and connect the ohmmeter between the two terminals. This test should be used after testing at the amplifier connector to determine if there is a fault in the entire circuit.


## Component Replacement

The two most common components to be replaced in the cruise control system are the servo and the switches. The following section covers replacement of these units.

**Servo Assembly Replacement.** Follow Photo Sequence 28 to replace the servo assembly.

Reverse the procedure to install the servo assembly. To adjust the actuator cable, leave the cable adjusting clip off and pull the cable until all slack is removed. Maintain light pressure on the cable and install the adjusting clip. The clip must snap into place.

**Switch Replacement.** Switch removal differs depending on location. If the switch is a part of the multiple switch assembly on the turn signal stock, refer to the service manual section for removing this switch. The following is a common method of switch replacement for switches contained in the steering wheel.

 **WARNING:** Follow the service manual procedure for disarming the air bag system before performing this task. Failure to disarm the air bag system may result in accidental deployment and personal injury.

With the air bag system properly disarmed, remove the air bag module. Disconnect the electrical connections to the switch assembly. Remove the screws that attach the switch assembly to the steering wheel. Then remove the switch.

To install the new switch assembly, position it into the steering wheel pad cover and attach the retaining screws. If the horn connectors had to be disconnected, attach them to the pad cover. Reinstall the air bag module and rearm the air bag system.



### SPECIAL TOOLS

Hand vacuum pump



### CAUTION:

Do not short the jumper wires from circuit 144 to circuits 145 or 146. Damage to the amplifier will result if the amplifier is connected while this is done.



### SPECIAL TOOLS

Ohmmeter

# PHOTO SEQUENCE 28

## TYPICAL PROCEDURE FOR REPLACING THE CRUISE CONTROL SERVO ASSEMBLY

All photos in this sequence are © Delmar/Cengage Learning.



**P28-1** Tools required to replace the servo assembly: fender covers, screwdriver set, combination wrench set, ratchet and socket set.



**P28-2** Remove the retaining screws attaching the speed control actuator cable to the accelerator cable bracket and intake manifold support bracket.



**P28-3** Disconnect the cable from the brackets.



**P28-4** Disconnect the speed control cable from the accelerator cable.



**P28-5** Disconnect the electrical connection to the servo assembly.



**P28-6** Remove the two retaining bolts that attach the servo assembly bracket to the shock tower.



**P28-7** Remove the two bolts that attach the servo assembly to the bracket.



**P28-8** Remove the servo and cable assembly.



**P28-9** Remove the two cable cover to servo assembly retaining bolt and pull off the cover.



P28-10 Remove the cable from the servo assembly.

## ELECTRONIC SUNROOF DIAGNOSIS

Troubleshooting the causes of slow, intermittent, or no sunroof operation is a relatively simple procedure. Unlike many systems, the sunroof operation is not usually integrated with other systems. Because the system stands alone, diagnostics are generally performed in the same manner as testing any other motor-driven accessory. The following is the diagnostic procedure used to troubleshoot the electronic sunroof system shown (Figure 14-39). In addition, refer to the diagnostic chart at the end of this chapter to determine the causes of other system malfunctions.

Slow sunroof operation may be caused by excessive resistance in the circuit or motor. Excessive resistance can be determined by performing a voltage drop test. Obtain the correct schematic for the vehicle being diagnosed and follow through the circuit to locate the cause of the excessive resistance. Resistance can also occur inside the motor as a result of brush wear, bushing wear, and corroded connections.

Shorted armature or field coils can also result in slow motor operation. An ammeter can be used to test the current draw of the circuit to determine motor condition. If testing

### Classroom Manual

Chapter 14, page 412



### SPECIAL TOOLS

- Test light
- DMM
- Ammeter
- Service manual

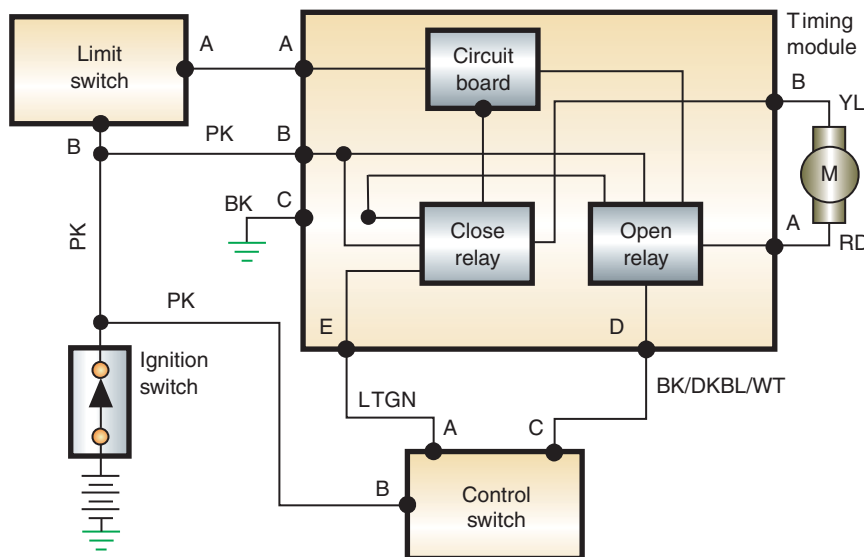


FIGURE 14-39 Electronic sunroof schematic.

© Delmar/Cengage Learning



the motor and its circuits does not locate the cause of slow operation, then the problem is mechanical. Check the drive cable and tracks for any signs of wear or damage.

Intermittent problems may be the result of loose or corroded connections. To locate the cause of an intermittent fault, operate the system while wiggling the wires. This will assist in isolating the location of the poor connection. Some systems also use a circuit breaker to protect the motor. It may be overheating and tripping prematurely, or there may be resistance to window movement in the rails. The circuit breaker will trip, then cool down and reset. Check that the glass is able to move easily in the rails. In addition, many intermittent problems are caused by a faulty control switch. Operate the control switch several times while performing the circuit test. Replace the switch if it fails at any time during the test.

Follow the procedures listed in your service manual to locate an intermittent or no operation fault within the circuit. Perform the usual visual inspections of the circuit before continuing. Be sure to check for proper system grounds.

### Classroom Manual

Chapter 14, page 417



### SPECIAL TOOLS

DMM  
Fused jumper wire  
Jumper wire



### CAUTION:

Perform the diagnostic test as fast as possible. Prolonged operation of the system at temperatures above 65°F (18.3°C) may cause permanent optical damage to the windshield.



### CAUTION:

Check the surface temperature of the windshield during testing. Turn off the system immediately if it gets too hot.

## ELECTRONICALLY HEATED WINDSHIELD SERVICE

The two basic styles of heated windshields require different approaches to diagnostics. However, in either system, check the operation of the alternator, alternator belt condition, and the windshield for damage before beginning service. Also, the system will not operate if the battery state of charge is low.

During the course of diagnosing the heated windshield system, it will become necessary to override the temperature sensor. The Ford system will not activate unless the interior temperatures are less than 40°F (4.4°C). To override the system, connect a jumper wire between the black test lead pigtail and ground. The test lead is usually located in the engine compartment close to the wiper motor.

For the GM system to turn on, inside vehicle temperatures must be below 65°F (18.3°C). To override the internal thermistor, ground terminal C of the data link connector.

The following is a service sample of the test procedures used to diagnose the GM-style system.

If the customer complains that the system does not turn on, verify this by starting the engine and pressing the activation switch. Observe the LED in the switch. The test procedure is determined by the attitude of the LED.

If the LED comes on for longer than 1/2 second but goes off again within 3 seconds, use the schematic (Figure 14-40) and follow these steps.

1. Measure the voltage at the data link connector terminal C. If it is within 2 volts of battery voltage, check for a short to battery voltage in the yellow wire. If the wire is good, replace the control module. If the voltage is not within 2 volts of battery voltage, continue testing.
2. Ground data link connector terminal C and start the engine. Press the activation switch to turn on the system. If the LED lights and the windshield heats, replace the control module. The internal thermistor is bad. However, it is not serviced separately from the control module.
3. Turn the ignition switch to the OFF position. Then return it to the RUN position. Measure the voltage from terminal B6 of the control module. If the measured voltage is less than 11.2 volts, there is an open or short in circuit 2.
4. With the ignition switch still in the RUN position, measure voltage at terminal A6. If battery voltage is not present, there is an open or short in circuit 50.
5. Measure the voltage between terminals A6 and A8 of the control module. If battery voltage is not present, measure the resistance between circuit 155 and ground. It must be less than 0.5 ohm.
6. With the ignition switch in the RUN position, measure voltage between terminals A6 and A3 while repeatedly pressing the activation switch. Zero volts should be indicated when the switch is pressed and 9.1 volts when it is released. Check circuit 648 for an

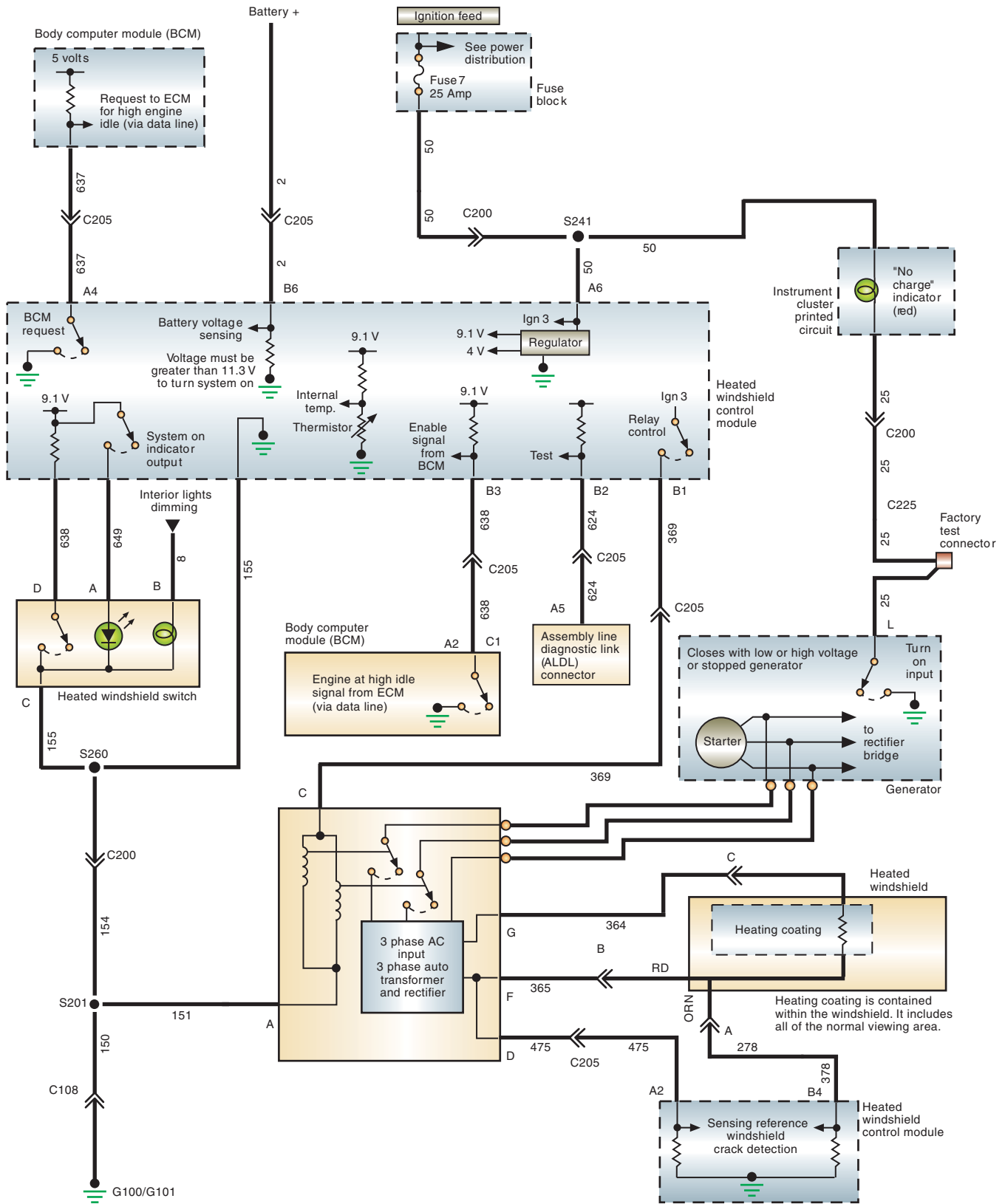


FIGURE 14-40 General Motors' heated windshield system.



### CAUTION:

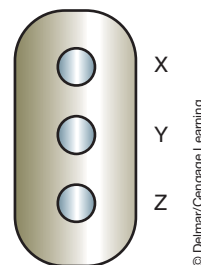
Measure the resistance on the windshield side of the connector. Measuring resistance on the controller side of the connector may damage the controller.

open if the measured voltage is different than these values. If circuit 648 is good, check the continuity of the activation switch when it is in the released position. Also, check for a good ground connection at terminal C of the switch.

7. Turn the ignition switch to the OFF position and disconnect the windshield connector. Measure the resistance of the windshield at the connector terminals. The resistance between terminals A and B should be less than 10 ohms. It should be less than 6 ohms between B and C. If the measured resistance values are different, inspect the connector. If the connector is good, replace the windshield.
8. Leave the windshield disconnected and measure the resistance of the windshield between each terminal of the connector to ground. All terminals should indicate 10,000 ohms or greater. If less than 10,000 ohms, check for shorts to ground between the windshield and the body.
9. Check circuit 475 for continuity between terminals D and A2 of the control module. Also check for continuity of circuit 378 between the windshield harness side connector terminal A and module terminal B4. If there is not continuity in either one of the circuits, repair the opens. If circuits 475 and 378 are good, replace the control module.

When confirming the complaint, if the LED remains on but the windshield does not heat, test the system as follows:

1. Start the engine and activate the system by pressing the switch.
2. Measure the three-phase voltage at the three posts on the back of the generator. Do not disconnect the connector at this time. Measure the voltage by back probing the connector. The voltmeter must be on a scale higher than 20 volts AC.
3. Refer to the diagram (Figure 14-41) and measure the voltage as follows:
  - X to Y
  - X to Z
  - Y to Z
4. In all cases, the voltage should be between 9 and 14 volts. If the voltage is within specifications, go to step 6. If the voltage is not within these limits, turn the ignition switch to the OFF position and disconnect the three wires from the generator. Repeat the test again. Replace the generator if the voltage is still not within the limits. If the voltage is between 9 and 14 volts, check the wires from the generator to the power module.
5. Disconnect the windshield connector and measure the resistance between terminals B and C. If the resistance is less than 3 ohms, replace the power module. If the resistance is more than 3 ohms, replace the windshield.
6. Place the ignition switch in the OFF position and disconnect the control module.
7. Connect a fused jumper wire between pin B1 of the control module connector and battery positive.
8. Start the engine and back probe between pins B and C of the connector with a voltmeter. Use 100-volt or greater DC scale. If the voltage is between 50 and 85 volts, replace the control module.



**FIGURE 14-41** Generator connector terminal identification.



9. With the seven pin connector to the control module disconnected, check to see if circuit 369 has continuity between the control module and terminal B1. Also, check that power module terminal C is free of shorts and grounds.
10. Check that circuit 151 has continuity between power module terminal A and ground.
11. If either circuit 369 or 151 has an open, repair as necessary.
12. If both circuits are good, measure the resistance between terminals G and F of the power module connector. If the resistance is less than 6 ohms, replace the power module. If the resistance is greater than 6 ohms, there is an open in circuit 364 or 365.

When confirming the customer complaint, if the LED illuminates for about 3 seconds and then turns off, test as follows:

1. Start the engine and allow it to warm (engine off high idle).
2. Activate the system. If internal temperatures are above 65°F (18.3°C), jump DLC terminal C to ground.
3. The engine idle speed should increase within a few seconds of activating the system. Go to step 4 if the engine does not increase speed. Go to step 7 if the engine speed increases.
4. Turn the ignition switch off and disconnect the control module.
5. Start the engine. Ground terminal A4 of the module connector with a fused jumper wire.
6. If the engine speed increases, there is a problem with the BCM or ECM. Follow the service manual procedures for diagnosing these units. If the engine speed does not increase, replace the control module.
7. With the engine running, back probe terminal B3 of the control module connector with a voltmeter.
8. Activate the system while observing the voltmeter. The voltage should drop from battery voltage to less than 4 volts in approximately 3 seconds. If the voltage fails to decrease, check the wire between A2 of the BCM and B3 of the control module. If the wire is good, the BCM or ECM is defective.
9. If the voltage drops according to specifications, replace the control module.



### CAUTION:

It is normal for the LED to turn on and then off after 3 seconds if the ignition switch is in the RUN position but the engine is not started. Be sure to verify the complaint with the engine running.

## AUDIO AND VIDEO ENTERTAINMENT

Today's audio/video systems integrate several different functions. They may include AM/FM radio, cassette player, CD player, DVD player, MP3 player, hands-free cell phone, and navigational systems. Most are diagnosed using a scan tool since the system will set fault codes when a failure is determined.

Because automotive technicians do not repair radios or system component units, there is a tendency to remove the unit when the customer has described having a particular problem before performing a thorough prediagnosis. In many cases, the units show "NO TROUBLE FOUND" and are sent back to the dealership or shop. Most of the problems could have been solved without taking the radio out of the dash.

Before removing the radio/component, do these simple checks to quickly determine whether the system problems are external:

- Test the vehicle's radio system outside, not inside a building. Make sure the hood is down.
- Most noise can be located on weak AM stations at the low-frequency end of the tuning band.
- Ignition noise on FM usually indicates a problem in the ignition system.
- If a test antenna is going to be used, the base must be grounded to the vehicle's body. DON'T HOLD THE MAST.
- Ninety percent of radio noise enters by way of the antenna.
- Most "rubber" hoses (vacuum, coolant, etc.) are electrically conductive, unless they have a white stripe.

### Classroom Manual

Chapter 14, page 422



### SPECIAL TOOLS

Scan tool  
Diagnostic RF sniffer

- When shielding hoses, wires, the dash, etc., use foil or screening material. Be sure to ground the material.
- A weak or fading AM signal is normally caused by an improperly adjusted antenna trimmer (when used).

The technician must determine the exact nature of the problem when performing a diagnosis. Determining whether the problem is intermittent or constant or whether the problem occurs when the vehicle is moving or stationary will help pinpoint the nature of the problem.

The diagnostic chart at the end of this chapter provides a guide to diagnosing radio performance complaints. Remember that the data bus is used for communications between the radio receiver and the amplifier. Be sure to confirm proper operation of this system.

Most complaints associated with the AM/FM radio are about poor reception. This is usually the result of an improper ground connection of the antenna. The base of the antenna provides a path to chassis ground. Resistance in any portion of the vehicle's ground path can affect the overall performance of the audio system. The following conditions should be checked whenever diagnosing a poor radio reception concern:

- Loose or corroded battery cable terminals.
- High-resistance body and engine grounds.
- Loss of antenna and audio system grounds.

When diagnosing the antenna, verify there is continuity between the antenna lead to the tip of the radio connector. Also verify there is no continuity between the antenna lead and chassis ground.

To inspect for the source of radio noise resulting from RFI or EMI, attempt to identify the component that is the source. For example, an ignition system problem can cause radio noise that will be engine speed related. Once the source is identified, the ground path and connections to that component should be checked. All ground connections must be verified prior to replacing any components. Some of the grounds and connections that need to be inspected include:

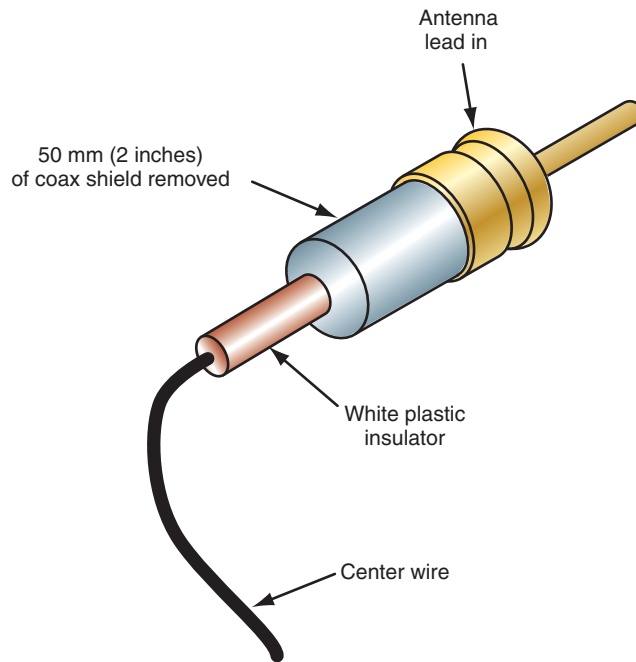
- Radio antenna base ground.
- Radio receiver chassis ground.
- Generator.
- Engine-to-body ground straps.
- Electric fuel pump.
- Ignition module.
- Heater core ground strap.
- Wiper motors.
- Blower motor.
- Exhaust system ground straps.

In addition, spark plugs and spark plug wire routing and condition should be checked.

A “diagnostic RF sniffer” tool can be made from an old piece of antenna lead-in from a mast or power antenna (Figure 14-42). This sniffer can be used, along with the radio, to locate “hot spots” that are generating radio frequency interference (RFI) noise. The noise can be found in wiring harnesses, in the upper part of the dash, or even between the hood and the windshield. When checking for noise on a wire, it is best to hold the sniffer parallel and close to the wire.

If the vehicle is equipped with an amplifier, speaker-related problems are diagnosed through the amplifier. For vehicles that are not equipped with an amplifier, speaker-related problems are diagnosed through the radio. Typical fault conditions that can be detected by the system are speaker circuits shorted to ground, shorted to voltage, shorted together, or open.

Like the radio, the CD system components generate DTCs for faults that can be retrieved using the scan tool. Use the diagnostic chart at the end of this chapter to assist in identifying common customer complaints for poor CD system performance.



**FIGURE 14-42** RF sniffer tool.

© Delmar/Cengage Learning

The satellite radio system will also generate DTCs that can be read by the scan tool. The system will perform diagnostic system checks for audio output, presence of the antenna, antenna signal, and current subscription status.

If there is no satellite radio audio out of speakers, first check that the satellite radio subscription is initiated and that it has not expired. Also check to confirm that the satellite antenna is not blocked from the satellite field of view. It is best to have the vehicle in an area that provides an unobstructed line of sight to the entire horizon when diagnosing a no-reception complaint. If the subscription is active and the antenna is not obstructed, then a hardware failure is indicated. This will require repair or replacement of the satellite radio module or the vehicle's radio, amplifier, or wire harness as directed in the service manual diagnostic procedures.

Another concern may be the display of "Updating Channels" on the radio screen. This may indicate a hardware communication failure. Confirm the satellite radio module is communicating on the data bus.

## CASE STUDY

The customer complains that although the fan blower motor operates well in low- and medium-speed positions, it runs slow in the high-speed position. A look at the wiring schematic (Figure 14-43) for the circuit indicates that the resistor block does not control high-speed operation. Because the motor operates properly in low and medium speeds, the

fault is not in the motor or the power supply feed. By examining the schematic, the only place that there could be resistance in the high-speed circuit is at the switch wiper or in the circuit between the switch and the resistor block. A voltage drop test confirms the location of the resistance is the connector to the switch.

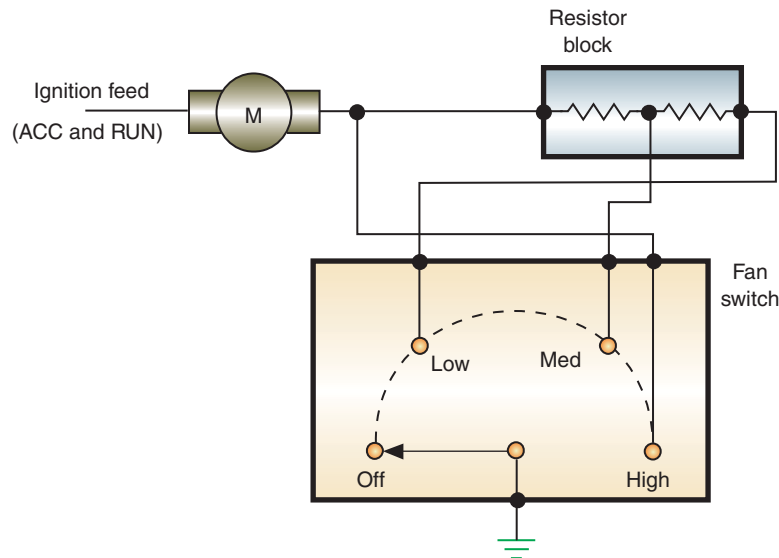


FIGURE 14-43 Three-speed blower motor schematic.

© Delmar/Cengage Learning

## TERMS TO KNOW

Accumulator  
 Control assembly  
 Dump valve  
 False Wipe  
 Functional test  
 Grids  
 KOEO  
 KOER  
 Lamp sequence check  
 Park switch  
 Pinpoint test  
 Resistor block  
 Self-test input (STI)  
 Servo  
 Servomotor  
 Tin

## CASE STUDY

The owner of a 2010 Charger says the automatic door lock feature fails to operate. The technician checks all accessible connections.

Next, a scan tool is connected to the diagnostic tester and the output test is initiated. The door locks operate properly while in this test mode. The technician then initiates the switch test. The scan tool indicates the driver's-side door ajar switch is constantly reading open. The service manual instructs the technician to disconnect the door ajar switch connector. When disconnected, the scan tool indicates the switch is open. Next, a jumper wire is connected across the harness side connector. The scan tool still indicates the switch is open. According to the

service manual, when the jumper wire is connected, the input state should indicate closed.

Voltage from the cabin compartment node (CCN) to the switch connector is tested. The voltage should be 12 volts, but 0 volts is measured. It is found that the wire between the CCN and the connector is good. According to the service information, the CCN must be replaced since it is not sending out the 12-volt reference signal to the left-front door switch.

The resistance of the terminal lead from the CCN to the switch is measured. Per the service manual specifications, the resistance value is too high and the CCN requires replacement.

## ASE-STYLE REVIEW QUESTIONS

- All of the following can cause the horn to sound continuously EXCEPT:
  - Circuit between relay and horn shorted to power.
  - Short to ground between relay and horn.
  - Horn switch contacts stuck closed.
  - Short to ground between the relay coil and the horn switch.
- The two-speed windshield wiper operates in HIGH position only.
 

*Technician A* says the low-speed brush may be worn. *Technician B* says the motor has a faulty ground connection. Who is correct?

  - A only
  - B only
  - Both A and B
  - Neither A nor B

3. What is the LEAST likely cause of slow windshield wiper operation?
- Binding mechanical linkage.
  - Excessive resistance in the motor's ground circuit.
  - Short to power at the low-speed brush.
  - Worn common brush.
4. On a vehicle equipped with an immobilizer system, the engine starts for a few seconds and then dies.  
What is the LEAST likely cause of this?
- An invalid key was used.
  - A misadjusted doorjamb switch.
  - The immobilizer module has not been initialized.
  - Lost communication between immobilizer module and PCM.
5. A customer states that the vehicle alarm will trip when there is no apparent attempt of entry.  
*Technician A* says the fault may be a loose lock cylinder.  
*Technician B* says a misadjusted jamb switch may be the cause.  
Who is correct?
- A only
  - B only
  - Both A and B
  - Neither A nor B
6. The heater fan motor does not operate in high-speed position.  
*Technician A* says the cause is a faulty resistor block.  
*Technician B* says the motor is defective.  
Who is correct?
- A only
  - B only
  - Both A and B
  - Neither A nor B
7. The grid of a rear window defogger is only removing some areas of fog from the window.  
*Technician A* says the timer circuit is faulty.  
*Technician B* says the grid is damaged.  
Who is correct?
- A only
  - B only
  - Both A and B
  - Neither A nor B
8. The passenger-side power window does not operate in either direction, despite which switch is used (master or window).  
*Technician A* says the problem is a faulty master switch.  
*Technician B* says the problem is a worn motor.  
Who is correct?
- A only
  - B only
  - Both A and B
  - Neither A nor B
9. A sunroof is opening slower than normal and appears to be "jerky" in its operation. The most likely cause of this problem is:
- A shorted armature or field coil in the sunroof motor.
  - A stuck open limit switch.
  - A stuck closed limit switch.
  - A stuck OPEN switch.
10. The power door locks will lock the door, but they do not unlock it.  
*Technician A* says the motor is faulty.  
*Technician B* says the unlock relay is faulty.  
Who is correct?
- A only
  - B only
  - Both A and B
  - Neither A nor B

## ASE CHALLENGE QUESTIONS

1. *Technician A* says weak and fading AM signals could be the result of a bad or ungrounded antenna.  
*Technician B* says that most radio noise enters by way of the radio.  
Who is correct?
- A only
  - B only
  - Both A and B
  - Neither A nor B
2. A vehicle's cruise control system is inoperative. Which of the following will not cause this problem?
- Stuck closed brake pedal vacuum switch.
  - Open stoplamp switch.
  - Inoperative speedometer.
  - Open cruise engagement switch.

3. Testing of the alarm relay is being discussed.  
*Technician A* says if the system fails to operate with the relay bypassed, the relay is defective.  
*Technician B* says the relay is generally tested using an ammeter.  
 Who is correct?  
 A. A only                      C. Both A and B  
 B. B only                      D. Neither A nor B
4. A completely inoperative GM automatic door lock system is being discussed; the door locks will not open or close manually or automatically.  
*Technician A* says that there may be an open in the power feed circuit to the automatic door lock controller.  
*Technician B* says that one or more doorjamb switches may be faulty.  
 Who is correct?  
 A. A only                      C. Both A and B  
 B. B only                      D. Neither A nor B
5. Radio system problems are being discussed.  
*Technician A* says that on some radios a weak AM signal can be caused by an improperly adjusted antenna trimmer.  
*Technician B* says that it is acceptable to locate radio wires near most rubber hoses.  
 Who is correct?  
 A. A only                      C. Both A and B  
 B. B only                      D. Neither A nor B
6. The horn of a vehicle equipped with a horn relay is sounding continuously.  
 Which of the following could be the cause of this problem?  
 A. Shorted horn relay coil.  
 B. Open horn switch.  
 C. Grounded wire on the switched side of the horn relay.  
 D. Open horn relay coil.
7. The high-speed position of a two-speed windshield wiper system is inoperative; the low-speed position is fine.  
 Which of the following could cause this problem?  
 A. High resistance on the ground side of the motor.  
 B. Open motor resistor.  
 C. Faulty park switch.  
 D. Worn motor brush.
8. An A/C blower motor is turning slowly. A voltmeter that is connected across the power and ground terminals of the motor is indicating 13.6 volts when the blower speed switch is in the HIGH position and the engine is running; an ammeter indicates that the motor is drawing about 3 amps.  
*Technician A* says that the blower motor ground circuit may have excessive resistance.  
*Technician B* says that the blower motor armature may be binding.  
 Who is correct?  
 A. A only                      C. Both A and B  
 B. B only                      D. Neither A nor B
9. The blower motor of a vehicle equipped with a ground-side controlled motor circuit is running at high speed whenever the engine is running; the blower switch has no control of the motor speed.  
*Technician A* says that ground side of the motor may be shorted to ground.  
*Technician B* says that the blower switch contacts may have excessive resistance.  
 Who is correct?  
 A. A only                      C. Both A and B  
 B. B only                      D. Neither A nor B
10. A power window motor is inoperative. A voltmeter that is connected across the power and ground terminals of the motor indicates 0 volts when the window switch is moved to the DOWN position; when the ground lead of the voltmeter is connected to a chassis ground (and the switch is in the DOWN position) the voltmeter then indicates 12.6 volts.  
*Technician A* says that the window motor has an open internal circuit.  
*Technician B* says that the window switch may have an open contact.  
 Who is correct?  
 A. A only                      C. Both A and B  
 B. B only                      D. Neither A nor B



Name \_\_\_\_\_ Date \_\_\_\_\_

## DIAGNOSING A WINDSHIELD WIPER CIRCUIT

Upon completion of this job sheet, you should be able to diagnose an inoperative or poorly working windshield wiper system.

### ASE Correlation

This job sheet is related to the ASE Electrical/Electronic System Certification Exam's content area: *Horn and Wiper/Washer Diagnosis and Repair*; task: Diagnose the cause of wiper problems, including constant, intermittent, poor speed control, parking problems, and no operation of wiper.

### Tools and Materials

- A vehicle
- Wiring diagram for the chosen vehicle
- Service information for the chosen vehicle
- A DMM

### Describe the vehicle being worked on:

Year \_\_\_\_\_ Make \_\_\_\_\_ Model \_\_\_\_\_  
 VIN \_\_\_\_\_ Engine type and size \_\_\_\_\_

### Procedure

Task Completed

1. Describe the general operation of the windshield wipers. Check the operation in all speeds and modes.

---



---



---



---

2. Check the mechanical linkages for evidence of binding or breakage. Record your findings.

---



---



---



---

---

**Task Completed**

3. Locate the wiring diagram for the windshield wiper circuit. Print out the diagram and highlight the power, grounds, and had the circuit controls. Attach the printout to this job sheet.
4. Describe how the motor is controlled to operate at different speeds.

---

---

---

---

5. Connect the voltmeter across the ground circuit; energize the motor. What was your reading on the meter? What does this indicate?

---

---

---

---

6. Probe the power feed to the motor in the various switch positions. Observe your voltmeter readings. What were they? What is indicated by these readings?

---

---

---

---

7. Describe the general operation of the windshield wiper motor.

---

---

---

---

Instructor's Response \_\_\_\_\_

---

---

Name \_\_\_\_\_ Date \_\_\_\_\_

## TESTING THE WINDSHIELD WASHER CIRCUIT

Upon completion of this job sheet, you should be able to diagnose problems in the windshield washer circuit.

### ASE Correlation

This job sheet is related to the ASE Electrical/Electronic System Certification Exam's content area: *Horn and Wiper/Washer Diagnosis and Repair*; task: Diagnose the cause of constant, intermittent, or no operation of windshield washer.

### Tools and Materials

- A vehicle
- Wiring diagram for the chosen vehicle
- A DMM
- Hand tools

### Describe the vehicle being worked on:

Year \_\_\_\_\_ Make \_\_\_\_\_ Model \_\_\_\_\_  
 VIN \_\_\_\_\_ Engine type and size \_\_\_\_\_

### Procedure

\_\_\_\_\_  
 Task Completed

1. Describe the general operation of the windshield wipers.

\_\_\_\_\_

\_\_\_\_\_

\_\_\_\_\_

\_\_\_\_\_

2. Check the fluid level in the washer fluid reservoir.  
 Replenish the level, if necessary.

3. Remove the fluid output line from the washer pump.  
 Activate the washer pump. Does fluid come out of the pump? \_\_\_\_\_  
 What are your conclusions from this?

\_\_\_\_\_

\_\_\_\_\_

\_\_\_\_\_

\_\_\_\_\_

4. If fluid comes out of the pump but none sprays on the windshield, disconnect the fluid lines from the washer fluid nozzles. Activate the pump. Does fluid come out of the pump? \_\_\_\_\_ What are your conclusions from this?

---

---

---

---

5. If the pump does not operate when switched on, run a jumper wire from the battery to the pump. What happened? What are your conclusions from this test?

---

---

---

---

6. Connect the voltmeter across the ground of the pump. Activate the pump. Describe what happened. What are your conclusions from this?

---

---

---

---

7. What are your recommendations about the windshield washer system?

---

---

---

---

Instructor's Response \_\_\_\_\_

---

---

Name \_\_\_\_\_ Date \_\_\_\_\_

## TESTING A REAR WINDOW DEFOGGER

Upon completion of this job sheet, you should be able to diagnose inoperative and poorly working rear window defogger units.

### ASE Correlation

This job sheet is related to the ASE Electrical/Electronic System Certification Exam's content area: *Accessories Diagnosis and Repair*; task: Diagnose the cause of poor, intermittent, or no operation of rear window defogger.

### Tools and Materials

A vehicle with a rear window defogger  
 Wiring diagram for the chosen vehicle  
 A DMM

### Describe the vehicle being worked on:

Year \_\_\_\_\_ Make \_\_\_\_\_ Model \_\_\_\_\_  
 VIN \_\_\_\_\_ Engine type and size \_\_\_\_\_

### Procedure

1. From the wiring diagram, identify the power feed to the rear window defogger. With the circuit activated, check for voltage at the power terminal to the defogger unit. Was there battery voltage present? \_\_\_\_\_  
 If no voltage was present, continue your testing at the control switch.   
 If much less than battery voltage is present at the terminal, check for excessive resistance in the power circuit.
  
2. Identify the ground circuit for the defogger; measure the voltage drop across this part of the circuit. Your reading is \_\_\_\_\_. If more than 0.1 volt, check the wire, connectors, and ground connection for the cause of higher-than-normal resistance.
  
3. If all of the grids in the defogger circuit are good, applied voltage should be dropped across each grid. To test the condition of each grid, measure the voltage drop across each grid, starting from the top grid and moving down. List your findings below.

---

---

---

---

---

---

---

---

Task Completed

4. If one or more of the grids do not drop applied voltage, continue your diagnosis by moving the negative meter lead toward the positive side of the grid and watch the meter. When battery voltage is measured, this indicates there is an open after that point. The grid should be repaired.
5. On a working grid, connect the positive lead of the meter to the power feed terminal and move the negative to the following positions; record your measured voltage.
- 3/4 of the way across the grid \_\_\_\_\_
- 1/2 of the way across the grid \_\_\_\_\_
- 1/4 of the way across the grid \_\_\_\_\_
- Describe what is happening.

---

---

---

---

6. Turn off the circuit, measure the resistance across the following points of the grid, and record your resistance readings.
- 3/4 of the way across the grid \_\_\_\_\_
- 1/2 of the way across the grid \_\_\_\_\_
- 1/4 of the way across the grid \_\_\_\_\_
- Describe why you had these readings.

---

---

---

---

Instructor's Response \_\_\_\_\_

---

---



Name \_\_\_\_\_ Date \_\_\_\_\_

## TESTING THE ELECTRONIC CRUISE CONTROL SYSTEM

Upon completion of this job sheet, you should be able to test the electronic cruise control system using a scan tool or stand-alone diagnostic routines and determine needed repairs.

### ASE Correlation

This job sheet is related to the ASE Electrical/Electronic System Certification Exam's content area: *Accessories Diagnosis and Repair*; tasks: Diagnose the cause(s) of unregulated, intermittent, or no operation of cruise control. Inspect, test, and repair switches, relays, and the electronic controller of the cruise control circuits.

### Tools and Materials

- A vehicle equipped with electronic cruise control
- Scan tool
- Service information

### Describe the vehicle being worked on:

Year \_\_\_\_\_ Make \_\_\_\_\_ Model \_\_\_\_\_  
 VIN \_\_\_\_\_ Engine type and size \_\_\_\_\_

### Procedure

Task Completed

1. Does the system have a stand-alone computer or is the system a part of the PCM functions?  
 STAND-ALONE     PCM

2. If possible, perform the simulated road test and record your results.

\_\_\_\_\_  
 \_\_\_\_\_

3. Are there any other related symptoms?     Yes     No  
 If yes, describe the symptom.

\_\_\_\_\_  
 \_\_\_\_\_

4. Refer to the proper service information to determine if a self-diagnostic routine can be performed. If so, describe how to enter diagnostics.

\_\_\_\_\_  
 \_\_\_\_\_  
 \_\_\_\_\_  
 \_\_\_\_\_

5. Is the self-diagnostic routine capable of displaying fault codes?  Yes  No

6. Perform the procedure listed in step 4 and record the results and any DTCs:

---

---

7. Use a scan tool and access the electronic cruise control system. Does the scan tool indicate that DTCs are present?  Yes  No

If yes, record the DTCs.

---

---

8. Based on the results so far, what tests need to be performed to find the cause of the fault?

---

---

9. Perform the tests listed in step 8. What is your determination and recommendation?

---

---

Instructor's Response \_\_\_\_\_

---

---

Name \_\_\_\_\_ Date \_\_\_\_\_

## TESTING THE ANTITHEFT SYSTEM OPERATION

Upon completion of this job sheet, you should be able to test the antitheft system operation through the self-test diagnostic routine and determine needed repairs.

### ASE Correlation

This job sheet is related to the ASE Electrical/Electronic System Certification Exam's content area: *Accessories Diagnosis and Repair*; tasks: Diagnose the cause(s) of false, intermittent, or no operation of antitheft systems.

### Tools and Materials

- A vehicle equipped with an antitheft system
- Scan tool
- Service information

### Describe the vehicle being worked on:

Year \_\_\_\_\_ Make \_\_\_\_\_ Model \_\_\_\_\_  
 VIN \_\_\_\_\_ Engine type and size \_\_\_\_\_

### Procedure

Task Completed \_\_\_\_\_

1. Can the system self-diagnostic test be performed stand-alone or through the use of a scan tool?  
 STAND-ALONE       SCAN TOOL

2. If it can be performed by stand-alone, describe how the process is performed.

\_\_\_\_\_

\_\_\_\_\_

\_\_\_\_\_

3. If a scan tool must be used, list the screen menu selections required to perform the self-test.

\_\_\_\_\_

\_\_\_\_\_

\_\_\_\_\_

\_\_\_\_\_

4. Enter the diagnostic self-test and record your results.

\_\_\_\_\_

\_\_\_\_\_

\_\_\_\_\_

5. Based on the results so far, what tests need to be performed to find the cause of the fault?

---

---

6. Perform the tests listed in step 5. What is your determination and recommendation?

---

---

Instructor's Response \_\_\_\_\_

---

---

Name \_\_\_\_\_ Date \_\_\_\_\_

## PROGRAMMING AN IMMOBILIZER KEY

Upon completion of this job sheet, you should be able to determine operating characteristics of the immobilizer system and properly program keys.

### ASE Correlation

This job sheet is related to the ASE Electrical/Electronic System Certification Exam’s content area: *Accessories Diagnosis and Repairs*; task: Diagnose the cause of false, intermittent, or no operation of antitheft system.

### Tools and Materials

- Vehicle equipped with an immobilizer system
- Extra keys
- Scan tool
- PIN (if required)
- Service information

### Describe the vehicle being worked on:

Year \_\_\_\_\_ Make \_\_\_\_\_ Model \_\_\_\_\_  
 VIN \_\_\_\_\_ Engine type and size \_\_\_\_\_

### Procedure

\_\_\_\_\_  
 Task Completed

#### Task One

1. According to the service information, does the immobilizer system of the assigned vehicle support customer programming of extra keys?  Yes  No  
 If yes, describe the procedure.

\_\_\_\_\_  
 \_\_\_\_\_  
 \_\_\_\_\_

2. Obtain an extra key from your instructor and attempt to start the vehicle with the new key. Describe the results.

\_\_\_\_\_  
 \_\_\_\_\_

3. Perform the customer-programming method described in step 1 to program a new key. How do you know the key was successfully programmed?

\_\_\_\_\_  
 \_\_\_\_\_

Task Completed

**Task Two**

1. Connect the scan tool to the DLC and access the immobilizer system.
2. If possible, perform a Module ID and record the following items:  
Version: \_\_\_\_\_ Part Number: \_\_\_\_\_ Country Code: \_\_\_\_\_

3. Does the immobilizer system on the assigned vehicle require the use of a PIN?  
 Yes  No  
If yes, obtain the PIN for the vehicle and record it:

4. How do you obtain the PIN?

---

---

5. If an incorrect PIN is entered or the correct procedure are not followed, are there any actions that must be done to reenter the programming mode?  Yes  No  
If yes, describe what must be done.

---

---

6. Is there a special procedure that must be followed if the PCM is replaced on the assigned vehicle?  Yes  No  
If yes, describe the procedure.

---

---

7. Is there a special procedure that must be followed if the immobilizer module is replaced on the assigned vehicle?  Yes  No  
If yes, describe the procedure.

---

---

8. Do the keys have to be reprogrammed after the SKIM is replaced?  Yes  No

9. Use the scan tool to erase all current ignition keys.
10. Attempt to start the engine and record the results.

---

---

11. Use the scan tool to read DTCs and record.

---

---



12. Use the scan tool and access the function to program ignition keys and follow the instructions on the scan tool or in the service manual. Does the vehicle start?

Yes  No

Task Completed

13. Clear any DTCs that were set.

**Task Three**

1. Wrap one of the programmed keys with aluminum foil and attempt to start the engine. Record your results.

---

---

2. Use the scan tool to read any DTCs in the system and record.

---

---

3. According to the service manual, what could cause the DTCs to set?

---

---

Instructor's Response \_\_\_\_\_

---

---

DIAGNOSTIC CHART 14-1	
PROBLEM AREA:	Horn system
SYMPTOMS:	Horn sounds even when switch is not activated
POSSIBLE CAUSES:	1. Faulty horn switch 2. Horn control circuit shorted to ground 3. Faulty horn relay

DIAGNOSTIC CHART 14-2	
PROBLEM AREA:	Horn system
SYMPTOMS:	Intermittent horn operation
POSSIBLE CAUSES:	1. Faulty horn switch 2. Poor clock spring contacts 3. Faulty horn relay 4. Poor ground connection at horn 5. Poor ground connection at switch

<b>DIAGNOSTIC CHART 14-3</b>	
PROBLEM AREA:	Horn system
SYMPTOMS:	Horn fails to sound when the horn switch is activated
POSSIBLE CAUSES:	<ol style="list-style-type: none"> <li>1. Blown fuse</li> <li>2. Faulty horn switch</li> <li>3. Poor clock spring contacts</li> <li>4. Faulty horn relay</li> <li>5. Poor ground connection at horn</li> <li>6. Poor ground connection at switch</li> </ol>

<b>DIAGNOSTIC CHART 14-4</b>	
PROBLEM AREA:	Wiper system operation
SYMPTOMS:	Wipers operate any time the ignition switch is in the RUN position.
POSSIBLE CAUSES:	<ol style="list-style-type: none"> <li>1. Faulty wiper switch</li> <li>2. Defective park switch or activation arm</li> <li>3. Shorted control circuit</li> </ol>

<b>DIAGNOSTIC CHART 14-5</b>	
PROBLEM AREA:	Wiper system operation
SYMPTOMS:	Wipers operate some of the time
POSSIBLE CAUSES:	<ol style="list-style-type: none"> <li>1. Poor ground connection</li> <li>2. Poor control circuit connection</li> <li>3. Faulty switch</li> <li>4. Worn motor contacts or brushes</li> </ol>

<b>DIAGNOSTIC CHART 14-6</b>	
PROBLEM AREA:	Wiper system operation
SYMPTOMS:	Wipers fail to function when switch is activated
POSSIBLE CAUSES:	<ol style="list-style-type: none"> <li>1. Blown fuse</li> <li>2. Open in the control circuit</li> <li>3. Short in the control circuit</li> <li>4. Faulty wiper motor</li> <li>5. Poor ground connection</li> <li>6. Mechanical linkage binding</li> <li>7. Faulty wiper switch</li> </ol>

<b>DIAGNOSTIC CHART 14-7</b>	
PROBLEM AREA:	Wiper system operation
SYMPTOMS:	<ol style="list-style-type: none"> <li>1. Wipers only operate on low speed</li> <li>2. Wipers only operate on high speed</li> </ol>
POSSIBLE CAUSES:	<ol style="list-style-type: none"> <li>1. Faulty wiper switch</li> <li>2. Worn brushes</li> <li>3. Poor control circuit connections</li> <li>4. Open in control circuit</li> </ol>

<b>DIAGNOSTIC CHART 14-8</b>	
PROBLEM AREA:	Wiper system operation
SYMPTOMS:	1. Wipers stop at on windshield when switch is turned off 2. Wipers remain on when wiper switch is turned off
POSSIBLE CAUSES:	1. Faulty park switch 2. Activation arm broken or out of adjustment

<b>DIAGNOSTIC CHART 14-9</b>	
PROBLEM AREA:	Wiper system operation
SYMPTOMS:	Wipers will not shut off
POSSIBLE CAUSES:	1. Faulty switch 2. Faulty park switch or circuit

<b>DIAGNOSTIC CHART 14-10</b>	
PROBLEM AREA:	Intermittent wiper system operation
SYMPTOMS:	No intermittent wiper operation, low and high speed operate normally
POSSIBLE CAUSES:	Faulty switch

<b>DIAGNOSTIC CHART 14-11</b>	
PROBLEM AREA:	Wiper motor operation
SYMPTOMS:	Slow or no wiper operation
POSSIBLE CAUSES:	Faulty wiper motor Binding wiper linkage

<b>DIAGNOSTIC CHART 14-12</b>	
PROBLEM AREA:	Washer system operation
SYMPTOMS:	Washer operates without switch activation
POSSIBLE CAUSES:	1. Faulty switch 2. Short in control circuit

<b>DIAGNOSTIC CHART 14-13</b>	
PROBLEM AREA:	Washer system operation
SYMPTOMS:	Intermittent washers operation
POSSIBLE CAUSES:	1. Faulty switch 2. Faulty pump 3. Poor control circuit connections 4. Poor ground connection

<b>DIAGNOSTIC CHART 14-14</b>	
PROBLEM AREA:	Washer system operation
SYMPTOMS:	Windshield washer fails to operate
POSSIBLE CAUSES:	<ol style="list-style-type: none"> <li>1. Blown fuse</li> <li>2. Faulty switch</li> <li>3. Faulty motor</li> <li>4. Poor ground connection</li> <li>5. Open or short in control circuit</li> <li>6. Restriction in hoses</li> </ol>

<b>DIAGNOSTIC CHART 14-15</b>	
PROBLEM AREA:	Power side window operation
SYMPTOMS:	Power windows operate slower than normal
POSSIBLE CAUSES:	<ol style="list-style-type: none"> <li>1. Control circuit resistance</li> <li>2. Faulty motor</li> <li>3. Poor ground connection</li> <li>4. Improperly adjusted regulators</li> <li>5. Binding linkages</li> </ol>

<b>DIAGNOSTIC CHART 14-16</b>	
PROBLEM AREA:	Power side window operation
SYMPTOMS:	Intermittent power window operation
POSSIBLE CAUSES:	<ol style="list-style-type: none"> <li>1. Faulty switch</li> <li>2. Faulty motor</li> <li>3. Poor ground connections</li> <li>4. Poor control circuit connections</li> <li>5. Binding linkage</li> <li>6. Faulty circuit breaker</li> </ol>

<b>DIAGNOSTIC CHART 14-17</b>	
PROBLEM AREA:	Power side window operation
SYMPTOMS:	Power windows fail to operate when switch is activated
POSSIBLE CAUSES:	<ol style="list-style-type: none"> <li>1. Faulty switch</li> <li>2. Faulty motor</li> <li>3. Poor ground connections</li> <li>4. Poor control circuit connections</li> <li>5. Binding linkage</li> <li>6. Faulty circuit breaker</li> </ol>

<b>DIAGNOSTIC CHART 14-18</b>	
PROBLEM AREA:	Power seat operation
SYMPTOMS:	Power seats operate slower than normal
POSSIBLE CAUSES:	<ol style="list-style-type: none"> <li>1. Control circuit resistance</li> <li>2. Faulty motor</li> <li>3. Poor ground connection</li> <li>4. Binding linkages</li> <li>5. Faulty motor transmission</li> </ol>

<b>DIAGNOSTIC CHART 14-19</b>	
PROBLEM AREA:	Power seat operation
SYMPTOMS:	Intermittent power seat operation
POSSIBLE CAUSES:	<ol style="list-style-type: none"> <li>1. Faulty switch</li> <li>2. Faulty motor</li> <li>3. Poor ground connections</li> <li>4. Poor control circuit connections</li> <li>5. Binding linkage</li> <li>6. Faulty circuit breaker</li> <li>7. Faulty transmission</li> </ol>

<b>DIAGNOSTIC CHART 14-20</b>	
PROBLEM AREA:	Power seat operation
SYMPTOMS:	Power windows fail to operate when switch is activated
POSSIBLE CAUSES:	<ol style="list-style-type: none"> <li>1. Faulty switch</li> <li>2. Faulty motor</li> <li>3. Poor ground connections</li> <li>4. Poor control circuit connections</li> <li>5. Binding linkage</li> <li>6. Faulty circuit breaker</li> <li>7. Faulty transmission</li> </ol>

<b>DIAGNOSTIC CHART 14-21</b>	
PROBLEM AREA:	Rear-window defogger operation
SYMPTOMS:	Rear-window defogger fails to clear the window
POSSIBLE CAUSES:	<ol style="list-style-type: none"> <li>1. Open in the grid</li> <li>2. Excessive circuit resistance</li> </ol>

<b>DIAGNOSTIC CHART 14-22</b>	
PROBLEM AREA:	Rear window defogger operation
SYMPTOMS:	Intermittent rear window defogger operation
POSSIBLE CAUSES:	<ol style="list-style-type: none"> <li>1. Faulty switch</li> <li>2. Poor circuit control connection</li> <li>3. Poor ground connection</li> <li>4. Loose connection to grid</li> </ol>

<b>DIAGNOSTIC CHART 14-23</b>	
PROBLEM AREA:	Rear window defogger operation
SYMPTOMS:	Defogger fails to clear window
POSSIBLE CAUSES:	<ol style="list-style-type: none"> <li>1. Faulty switch</li> <li>2. Blown fuse</li> <li>3. Open in control circuit</li> <li>4. Grid connection loose</li> <li>5. Broken grid bus</li> <li>6. Poor ground connection</li> </ol>

<b>DIAGNOSTIC CHART 14-24</b>	
PROBLEM AREA:	Power door lock system operation
SYMPTOMS:	Power door locks fail to operate some of the time
POSSIBLE CAUSES:	<ol style="list-style-type: none"> <li>1. Faulty circuit breaker</li> <li>2. Faulty switch</li> <li>3. Poor control circuit connections</li> <li>4. Poor ground connections</li> <li>5. Faulty motor or solenoid</li> <li>6. Faulty relay</li> </ol>

<b>DIAGNOSTIC CHART 14-25</b>	
PROBLEM AREA:	Power door lock system operation
SYMPTOMS:	All door locks do not operate in either direction
POSSIBLE CAUSES:	<ol style="list-style-type: none"> <li>1. Faulty circuit breaker</li> <li>2. Faulty master switch</li> <li>3. Open in control circuit</li> <li>4. Short in control circuit</li> <li>5. Poor ground connection</li> <li>6. Faulty relay</li> <li>7. Poor relay control circuit connections</li> </ol>

<b>DIAGNOSTIC CHART 14-26</b>	
PROBLEM AREA:	Power door lock system operation
SYMPTOMS:	One door lock does not operate in either direction
POSSIBLE CAUSES:	<ol style="list-style-type: none"> <li>1. Obstruction or binding of linkage</li> <li>2. Open in control circuit</li> <li>3. Short in control circuit</li> <li>4. Poor ground connection</li> <li>5. Faulty motor or solenoid</li> </ol>

<b>DIAGNOSTIC CHART 14-27</b>	
PROBLEM AREA:	Power door lock system operation
SYMPTOMS:	All locks work from one switch only
POSSIBLE CAUSES:	<ol style="list-style-type: none"> <li>1. Faulty switch</li> <li>2. Open in control circuit</li> <li>3. Short in control circuit</li> </ol>

<b>DIAGNOSTIC CHART 14-28</b>	
PROBLEM AREA:	Cruise control operation
SYMPTOMS:	Cruise control speed changes over or below set requests.
POSSIBLE CAUSES:	<ol style="list-style-type: none"> <li>1. Faulty servo.</li> <li>2. Defective controller.</li> <li>3. Faulty speed sensor.</li> <li>4. Throttle linkage adjustment.</li> <li>5. Faulty amplifier.</li> <li>6. Faulty dump valve.</li> </ol>



<b>DIAGNOSTIC CHART 14-29</b>	
PROBLEM AREA:	Cruise control operation
SYMPTOMS:	Cruise control fails to set.
POSSIBLE CAUSES:	<ol style="list-style-type: none"> <li>1. Faulty switch or circuit.</li> <li>2. Faulty servo or circuit.</li> <li>3. Defective controller.</li> <li>4. Poor ground connection.</li> <li>5. Poor control circuit connections.</li> <li>6. Faulty relay or circuit.</li> <li>7. Faulty speed sensor.</li> <li>8. Faulty speed sensor circuit.</li> <li>9. Throttle linkage adjustment.</li> <li>10. Faulty or misadjusted brake switch.</li> </ol>

<b>DIAGNOSTIC CHART 14-30</b>	
PROBLEM AREA:	Memory seat system operation
SYMPTOMS:	Seat does not move to preset positions; power seat works normally.
POSSIBLE CAUSES:	<ol style="list-style-type: none"> <li>1. Faulty motor position sensor.</li> <li>2. Faulty switch.</li> <li>3. Faulty control module.</li> <li>4. Open control module power feed circuit.</li> <li>5. Poor control module ground circuit.</li> <li>6. Improper park/neutral switch input.</li> <li>7. Bus communications error.</li> </ol>

<b>DIAGNOSTIC CHART 14-31</b>	
PROBLEM AREA:	Sunroof operation
SYMPTOMS:	Sunroof opens or closes slower than normal.
POSSIBLE CAUSES:	<ol style="list-style-type: none"> <li>1. Binding track.</li> <li>2. Excessive circuit resistance.</li> <li>3. Worn motor.</li> <li>4. Misadjusted linkage.</li> <li>5. Trim panel mispositioned.</li> <li>6. Cable guides mispositioned.</li> <li>7. Slipping motor clutch.</li> </ol>

<b>DIAGNOSTIC CHART 14-32</b>	
PROBLEM AREA:	Sunroof operation
SYMPTOMS:	Intermittent sunroof operation
POSSIBLE CAUSES:	<ol style="list-style-type: none"> <li>1. Worn or defective motor.</li> <li>2. Faulty controller.</li> <li>3. Loose ground connection.</li> <li>4. Poor control circuit connection.</li> <li>5. Binding linkage and/or tracks.</li> </ol>

<b>DIAGNOSTIC CHART 14-33</b>	
PROBLEM AREA:	Sunroof operation
SYMPTOMS:	Sunroof fails to move in either direction
POSSIBLE CAUSES:	<ol style="list-style-type: none"> <li>1. Worn or defective motor.</li> <li>2. Faulty controller.</li> <li>3. Loose ground connection.</li> <li>4. Poor control circuit connection.</li> <li>5. Binding linkage and/or tracks.</li> <li>6. Faulty circuit breaker or fuse.</li> <li>7. Trim panel mispositioned.</li> <li>8. Cable guides mispositioned.</li> <li>9. Slipping motor clutch.</li> </ol>

<b>DIAGNOSTIC CHART 14-34</b>	
PROBLEM AREA:	Antitheft system operation
SYMPTOMS:	System fails to arm or to operate some of the time.
POSSIBLE CAUSES:	<ol style="list-style-type: none"> <li>1. Faulty controller.</li> <li>2. Defective switches.</li> <li>3. Poor wire connections.</li> <li>4. Poor ground connections.</li> </ol>

<b>DIAGNOSTIC CHART 14-35</b>	
PROBLEM AREA:	Antitheft system operation
SYMPTOMS:	System won't disarm.
POSSIBLE CAUSES:	<ol style="list-style-type: none"> <li>1. Lock cylinder disarm switch loose.</li> <li>2. Open in the lock cylinder disarm switch circuit.</li> <li>3. Defective lock cylinder disarm switch.</li> <li>4. Defective lock cylinder.</li> <li>5. Faulty control module power and ground.</li> <li>6. Faulty control module.</li> </ol>

<b>DIAGNOSTIC CHART 14-36</b>	
PROBLEM AREA:	Antitheft system operation
SYMPTOMS:	System trips and sounds alarm by itself.
POSSIBLE CAUSES:	<ol style="list-style-type: none"> <li>1. Doorjamb, hood, or trunk switch loose.</li> <li>2. Loose connection in doorjamb switch, hood switch, or trunk switch circuit.</li> <li>3. Defective doorjamb, hood, or trunk switch.</li> <li>4. Faulty control module.</li> </ol>

<b>DIAGNOSTIC CHART 14-37</b>	
PROBLEM AREA:	Antitheft system operation
SYMPTOMS:	System won't trip when door is opened.
POSSIBLE CAUSES:	<ol style="list-style-type: none"> <li>1. Doorjamb switch circuit open.</li> <li>2. Faulty doorjamb switch.</li> <li>3. Faulty control module.</li> </ol>

<b>DIAGNOSTIC CHART 14-38</b>	
PROBLEM AREA:	Immobilizer system
SYMPTOMS:	Indicator lamp flashes during bulb check. Vehicle started and dies.
POSSIBLE CAUSES:	1. Invalid key. 2. Faulty key. 3. Faulty antenna. 4. Faulty module.

<b>DIAGNOSTIC CHART 14-39</b>	
PROBLEM AREA:	Immobilizer system
SYMPTOMS:	Indicator lamp stays on after bulb check.
POSSIBLE CAUSES:	1. Immobilizer fault has been detected. 2. Immobilizer system inoperative.

<b>DIAGNOSTIC CHART 14-40</b>	
PROBLEM AREA:	Keyless entry system operation
SYMPTOMS:	Keyless entry fails to operate.
POSSIBLE CAUSES:	1. Defective key pad. 2. Open circuit. 3. Shorted circuit. 4. Defective controller.

<b>DIAGNOSTIC CHART 14-41</b>	
PROBLEM AREA:	Heated windshield
SYMPTOMS:	The heated windshield system does not operate.
POSSIBLE CAUSES:	1. No power to heated windshield switch. 2. No power to heated windshield control module. 3. No power to heated windshield. 4. Inoperative AC generator output control relay. 5. Cracked windshield.

<b>DIAGNOSTIC CHART 14-42</b>	
PROBLEM AREA:	Audio system
SYMPTOMS:	Radio will not turn on.
POSSIBLE CAUSES:	1. Open power battery feed circuit. 2. Open ignition feed circuit. 3. Poor radio ground circuit. 4. Loss of bus communications.

<b>DIAGNOSTIC CHART 14-43</b>	
PROBLEM AREA:	Audio system
SYMPTOMS:	Radio will not produce sound.
POSSIBLE CAUSES:	<ol style="list-style-type: none"> <li>1. Open power battery feed circuit.</li> <li>2. Open ignition feed circuit.</li> <li>3. Poor ground connection.</li> <li>4. Defective radio.</li> <li>5. Open speaker circuit.</li> <li>6. Defective amplifier.</li> <li>7. Open power feed to amplifier.</li> <li>8. Poor amplifier ground circuit.</li> <li>9. Bus communications error.</li> <li>10. Stuck MUTE button.</li> </ol>

<b>DIAGNOSTIC CHART 14-44</b>	
PROBLEM AREA:	Audio system
SYMPTOMS:	No sound in AM or FM mode. CD audio operates normally.
POSSIBLE CAUSES:	<ol style="list-style-type: none"> <li>1. Faulty antenna connection.</li> <li>2. Poor antenna ground.</li> <li>3. Faulty radio.</li> </ol>

<b>DIAGNOSTIC CHART 14-45</b>	
PROBLEM AREA:	Audio system
SYMPTOMS:	Excessive noise heard in AM audio.
POSSIBLE CAUSES:	<ol style="list-style-type: none"> <li>1. Faulty antenna connection.</li> <li>2. Poor antenna ground.</li> <li>3. Faulty engine to chassis ground.</li> </ol>

<b>DIAGNOSTIC CHART 14-46</b>	
PROBLEM AREA:	Audio system
SYMPTOMS:	Poor radio reception
POSSIBLE CAUSES:	<ol style="list-style-type: none"> <li>1. Faulty antenna connection.</li> <li>2. Poor antenna ground.</li> <li>3. Faulty radio.</li> </ol>

## SERVICING PASSIVE RESTRAINT SYSTEMS



### BASIC TOOLS

Basic mechanic's tool set

Service information

### UPON COMPLETION AND REVIEW OF THIS CHAPTER, YOU SHOULD BE ABLE TO:

- Diagnose automatic seat belt systems.
- Enter air bag system self-diagnostics.
- Use a scan tool to properly retrieve air bag system trouble codes.
- Use the flashing warning light to retrieve air bag system trouble codes.
- Enter air bag diagnostics through the electronic climate control panel of GM vehicles equipped with digital instrument panels.
- Replace the air bag module according to manufacturer's service information standards.
- Replace the clockspring assembly according to manufacturer's service information standards.
- Service the air bag system safely.
- Validate the occupant classification system.

### INTRODUCTION

In this chapter, you will learn how to properly and safely service automatic passive restraint systems. Federal mandates concerning the equipping of these systems has assured that today's technician must be qualified to service them. The safety of the driver and/or passengers depends on the ability of the technician to properly diagnose and repair these systems.

Passive restraint systems can be either automatic seat belts, air bags, or a combination of both. In this chapter, you will learn how to diagnose automatic seat belt systems and replace their main components. You will also learn how to enter self-diagnostics and to retrieve trouble codes in the air bag system. Included in this chapter are procedures for replacing the air bag module and the clockspring. In addition, there are typical procedures for validating the occupant classification system (OCS).

### AUTOMATIC SEAT BELT SERVICE

The **automatic seat belt system** automatically puts the shoulder and/or lap belt around the driver or occupant. The automatic seat belt is operated by DC motors that move the belts by means of carriers on tracks. Even though the components used in the automatic seat belt system vary according to the manufacturer, the basic principles of locating and repairing the cause of a problem are similar. Refer to the service information to obtain a circuit diagram of the system. The circuit schematic, troubleshooting charts, and diagnostic charts will assist you in finding the fault.

In addition, most manufacturers provide a troubleshooting chart for the automatic seat belt system. Troubleshooting the circuits, switches, lamps, and motors as indicated in this chart requires only the skills described in previous chapters. In addition to the troubleshooting

**Classroom  
Manual**

Chapter 15, page 435

chart, an operational logic chart will provide helpful information when testing switches. Use a diagnostic chart to test the operation of the system and to determine faults with the module.

Some systems are capable of storing diagnostic trouble codes that can be retrieved by a scan tester. The scan tester is also used to perform a functional test of the system. To perform this test, turn the ignition switch to the RUN position and connect the scan tool to the diagnostic connector. Select the system test and follow the scan tool instructions. If there is a failure in the system, the scan tester will display the code.

## Drive Motor Assembly Replacement

A faulty drive motor can cause slow or no operation of the automatic seat belts. The motor must be replaced if the technician determines that it is the faulty component. A typical procedure for motor assembly replacement is described here.

## AIR BAG SAFETY AND SERVICE WARNINGS

Whenever working on the air bag system, it is important to follow some safety warnings. There are safety concerns with both deployed and live air bag modules. The air bag module is composed of the air bag and inflator assembly that is packaged in a single module. The module is mounted in the center of the steering wheel.

1. Wear safety glasses when servicing the air bag system.
2. Wear safety glasses when handling an air bag module.
3. Always disconnect the battery negative cable, isolate the cable end, and wait for the amount of time specified by the vehicle manufacturer before proceeding with the necessary diagnosis or service. The required amount of time may be as much as 15 minutes. Failure to observe this precaution may cause accidental air bag deployment and personal injury.
4. Handle all sensors with care. Do not strike or jar a sensor in such a manner that deployment may occur.
5. Replacement air bag system parts must have the same part number as the original. Replacement parts of lesser quality or questionable quality must not be used. Improper or inferior components may result in improper air bag deployment and injury to the vehicle occupants.
6. Do not strike or jar a sensor or an air bag system occupant restraint controller (ORC). This may cause air bag deployment or the sensor to become inoperative.
7. Before an air bag system is powered up, all sensors and mounting brackets must be properly mounted and torqued to ensure correct sensor operation. If sensor fasteners do not have the proper torque, improper air bag deployment may result in injury to the vehicle occupants.
8. When carrying a **live module** that has not been deployed, face the trim and bag away from your body.
9. Do not carry the module by its wires or connector.
10. When placing a live module on a bench, face the trim and air bag up.
11. Deployed air bags may have a powdery residue on them. Sodium hydroxide is produced by the deployment reaction and is converted to sodium carbonate when it comes into contact with atmospheric moisture. It is unlikely that sodium hydroxide will still be present. However, wear safety glasses and gloves when handling a deployed air bag. Wash hands after handling.
12. A live air bag module must be deployed before disposal. Because the deployment of an air bag is an explosive process, improper disposal may result in injury and in fines. A deployed air bag should be disposed of according to EPA and manufacturer procedures.



13. Do not use a battery- or AC-powered voltmeter, ohmmeter, or any other type of test equipment not specified in the service information. Never use a test light to probe for voltage.
14. Never reach across the steering wheel to turn the ignition switch on.

## DIAGNOSTIC SYSTEM CHECK

Before an air bag system is diagnosed, a system check is performed to avoid diagnostic errors. Always consult the manufacturer's specific information because the diagnostic system check may vary depending on the vehicle. The diagnostic system check involves observing the air bag warning light to determine if it is operating normally. A typical diagnostic system check follows:

1. Turn on the ignition switch and observe the air bag warning light. On some General Motors systems, this light should flash 7 to 9 times and then go out. On most other vehicles, the air bag warning light should be illuminated continually for 6 to 8 seconds and then go out. If the air bag warning light does not operate properly, further system diagnosis is necessary.
2. Observe the air bag warning light while cranking the engine. On many General Motors vehicles, this should cause the light to be illuminated continually. Always refer to the vehicle manufacturer's service information. During engine cranking, if the air bag warning light does not operate as specified by the vehicle manufacturer, a complete system diagnosis is required.
3. Observe the air bag warning light after the engine starts. The light should turn off a few seconds after the engine is started. If the air bag warning light remains off, there are no current DTCs in the air bag system module. If the air bag warning light remains on, obtain the DTCs with a scan tester or flash code method. Not all manufacturers provide for fault code retrieval by flash code methods—these vehicles will require a scan tool.

## RETRIEVING FAULT CODES

Most air bag systems will store fault codes that can be retrieved by either a scan tool or flash codes. In addition, some will allow display of fault codes on the digital panel cluster. After 1996, most manufacturers require the use of a scan tool.

### Scan Tool DTC Retrieval

Usually the air bag system will store two types of fault codes, active and stored. Active fault codes will turn the air bag warning lamp on. Stored codes are faults that are intermittent. Some manufacturers will also display how long (in minutes) a code was active. Depending on the manufacturer, the fault codes may be stored in nonvolatile memory. These codes will not be erased if the battery is disconnected or damaged. The only way to erase these codes is by use of the scan tool.

To retrieve fault codes, connect the scan tool to the data link connector (DLC). From 1996 on, this is usually the J1962 connector. On earlier model vehicles, there may be a separate DLC for the air bag system. This connector could be located under the seat, in the glove box, or in a direct connection to the air bag control module. Always refer to the proper service information to determine the DLC location. Turn the ignition switch to the run position.



**WARNING:** When turning the ignition switch on, do not reach across the steering wheel. Make sure that your body is away from any air bag modules that may deploy.



Follow the scan tool instruction to request supplement restraint system (SRS) Code Display. Record all stored and active fault codes. Active codes cannot be erased—the cause of the problem must be corrected. Use the proper diagnostic chart to trace the cause of the fault.

Some fault codes require that the ORC be replaced before any further diagnostics can be performed. For example, in some General Motors systems, a displayed code 52 indicates that enough accident information is stored in the EEPROM to fill its memory. In most systems, it takes four simultaneously closed arming and crash sensor events to fill the memory. This code requires that the ORC be replaced. A code 52 cannot be erased nor can any further diagnosis be performed until the ORC is replaced. If a code 71 is set, then an ORC failure is detected. A code 71 requires that the ORC be replaced before any other diagnostic procedures can be performed. A code 71 cannot be erased. If a code 52 or 71 is not displayed and there are other history codes, then the technician will be instructed to go to a diagnostic chart to locate the causes of the intermittent fault. If there are no history codes, diagnose remaining current codes from the lowest to the highest number.

General Motors called its control module as diagnostic energy reserve module (DERM).



### SPECIAL TOOLS

Jumper wire



### CAUTION:

Be sure to jumper the correct DLC terminals as identified in the service information. Jumping the incorrect terminal to ground may cause controller damage.

## Flash Code Retrieval

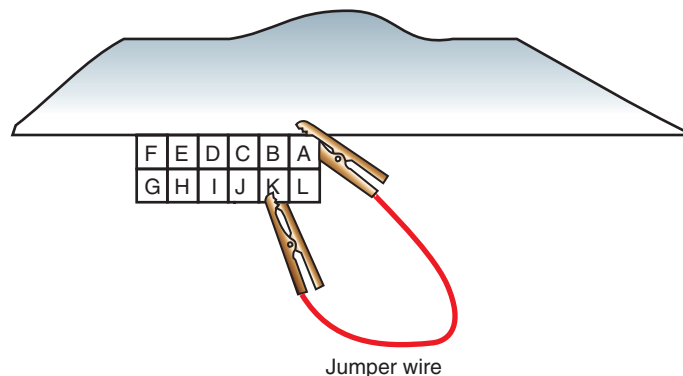
On vehicles that provide methods to retrieve fault codes by use of the warning lamp, always refer to the proper service information for the correct procedure. The following are typical examples to familiarize you with these methods.

**General Motors Flash Code Retrieval.** Flash codes allow the technician to retrieve current trouble codes without the use of a scan tool. Flash codes will not provide history codes. However, they will indicate whether there are any in memory. Always consult the proper vehicle manufacturer's service information before attempting to perform flash code retrieval.

The SRS diagnostic system check, described earlier, must be the first step of any SRS diagnosis. This checks the warning light and ability of the ORC to communicate through the data line.

With the ignition switch in the RUN position, connect a jumper wire from DLC terminal K to terminal A (Figure 15-1). The SRS warning lamp will display trouble codes through a series of flashes. Each displayed code will consist of a number of flashes that represent the first number. This number will be followed by a 1/2-second delay. Then the second number of the code will be flashed. For example, a code 52 would be displayed by five flashes, a 1/2-second pause, followed by two more flashes.

A code 12 will be displayed to indicate that the system is in flash code mode. This is not a fault code. Code 13 will be displayed if there are no history codes stored in memory.



© Delmar/Cengage Learning

**FIGURE 15-1** Jump the K terminal to ground to cause the module to enter self-diagnostics and to flash trouble codes.

Each code is displayed once, until all codes have been given. The codes will then repeat until the ground is lifted from DLC terminal K.

**Digital Instrument Panel Cluster Display.** Late-model Cadillac SRS diagnosis can be done by pressing the OFF and WARMER buttons on the electronic climate control panel (ECC) simultaneously. Press the LOW button four times to enter the SIR system. Then press HIGH to display any recorded codes (Figure 15-2).

**Ford Air Bag System Flash Code Diagnosis.** On some air bag systems, if a fault exists that could result in unwarranted air bag deployment, the ORC disarms the system. The ORC opens a thermal fuse inside to disarm the system. This fuse is not replaceable.



**SERVICE TIP:**  
On some Ford vehicles, the ORC provides an audible tone if the air bag warning light is not operating properly. Under this condition, the ORC provides five sets of five beeps every half hour.

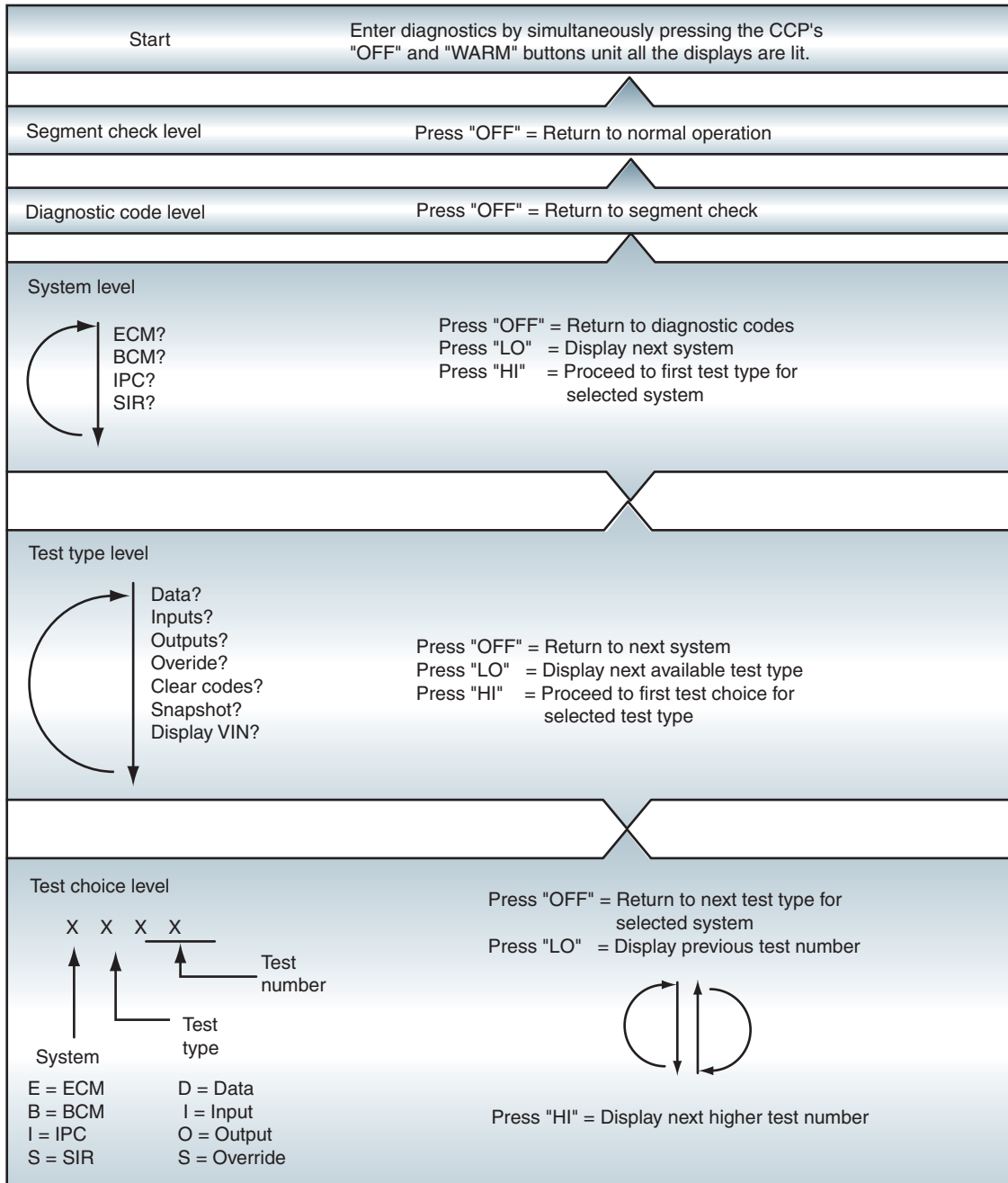


FIGURE 15-2 Onboard diagnostics using the ECC panel.

© Delmar/Cengage Learning

Ford calls some of its control modules air bag system diagnostic module (ASDM).



### SERVICE TIP:

On Toyota vehicles, if the air bag warning light flashes a DTC that is not on the fault code list for that model year, the control module is defective.

### Classroom Manual

Chapter 15, page 438



### SPECIAL TOOLS

DMM  
Test harness



**WARNING:** On Ford vehicles, the air bag deployment loop is connected to the battery positive terminal even with the ignition switch off. Therefore, air bag deployment is possible with the ignition switch off.

On many Ford vehicles, the air bag warning light begins to flash a DTC when a defect occurs in the air bag system. On many Ford systems, the air bag warning light prioritizes the DTCs and flashes the highest priority DTC if there is more than one fault in the system. When the fault represented by the flashing air bag warning light is corrected, the light flashes the DTC with the next highest priority—if a second fault exists. Since DTCs vary depending on the model year, the technician must have the DTC list for the model year being diagnosed.

**Toyota Air Bag System Flash Code Diagnosis.** On Toyota vehicles, air bag flash codes may be obtained by cycling the ignition switch on and off five times. Each time the ignition switch is cycled on or off, the technician must wait 20 seconds. Toyota air bag DTCs may also be obtained by connecting a special jumper wire, supplied by the vehicle manufacturer, between terminals TC and E1 in the DLC2. Before connecting this jumper wire, make sure the ignition switch is in the ACC or ON position. After the ignition switch is in one of these positions, wait 30 seconds. If there are no DTCs in memory, the air bag warning light flashes two times per second. When DTCs are present, the air bag warning light flashes these codes in numerical order. A DTC indicates a fault in a certain area such as a specific air bag sensor. Voltmeter or ohmmeter tests recommended in the vehicle manufacturer's service information are usually necessary to locate the exact cause of the problem.

## AIR BAG SYSTEM TESTING

Once the DTCs have been recorded, the technician will use the proper diagnostic chart to locate the fault. It is very important to follow *all* of the procedures listed. If the chart calls for the use of an ohmmeter to check a circuit, the technician would have been instructed to disconnect the harness from the air bag module in a prior step. If the technician ignores this step and connects the ohmmeter to the circuit, it is very possible that that air bag(s) will deploy.

Since most systems use shorting bars at the connectors, the technician must remember to lift these up in order to properly diagnose the harness. Most manufacturers provide test connections to be plugged into the harness connectors. These test connectors will lift up the shorting bar and also provide a test location for connecting the DMM.

## Honda Air Bag System Voltmeter Diagnosis



**WARNING:** Use only the vehicle manufacturer's recommended tools and equipment for air bag system service and diagnosis. Failure to observe this precaution may result in unwarranted air bag deployment and personal injury.



**WARNING:** Do not use battery-powered or AC-powered voltmeters or ohmmeters except those meters specified by the vehicle manufacturer. Failure to observe this precaution may result in unwarranted air bag deployment and personal injury.



**WARNING:** Do not use nonpowered probe-type test lights or self-powered test lights to diagnose the air bag system. Unwarranted air bag deployment and personal injury may result.



**WARNING:** Follow the vehicle manufacturer's service and diagnostic procedures. Failure to observe these precautions may cause inaccurate diagnosis, unnecessary repairs, or unwarranted air bag deployment resulting in personal injury.

Honda recommends testing the voltage at specific terminals on the control module, inflator modules, and sensor to diagnose some of their air bag systems. When voltage tests are performed at these terminals, special jumper wires are attached to allow the necessary voltmeter connections without damaging the terminals. Before connecting the special wiring harness, remove and isolate the battery negative cable. Then wait for the time period specified by the vehicle manufacturer.

Wiring harness A is connected to a terminal on the control module. Wiring harness B is connected in series between the large control module wiring connector and the matching terminals on the control module (Figure 15-3). Wiring harness C is connected in series at the inflator module connector and harness D is connected in series at the dash sensor (Figure 15-4). After the special wiring harness is connected, the voltmeter tests provided in the vehicle manufacturer's service information may be performed to diagnose the system.

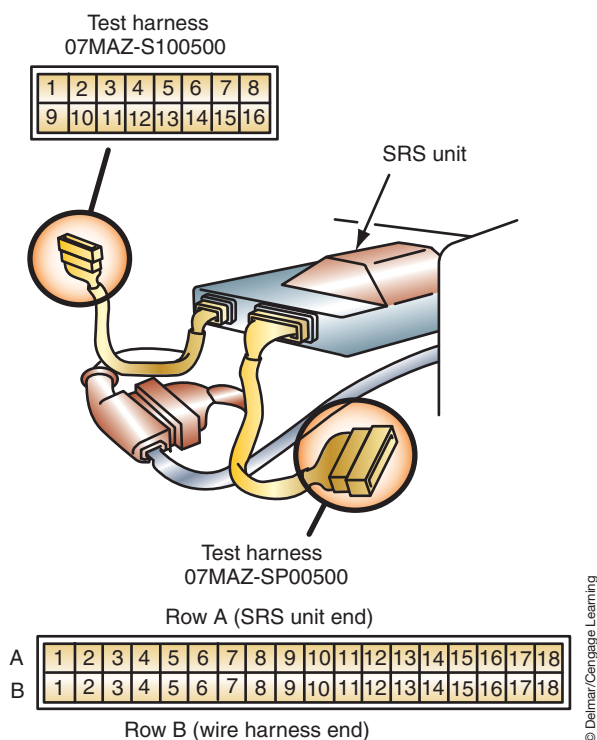
## Air Bag Simulators

Most automotive manufacturers, and many after-market suppliers, developed a method of performing air bag diagnostics by use of an air bag simulator (Figure 15-5). The simulator is connected in place of air bag components to represent a known good circuit and resistances. In addition, the simulator makes air bag service safer since the air bag module can be removed from the vehicle. The simulator allows for a safe test sequence that should identify any circuit

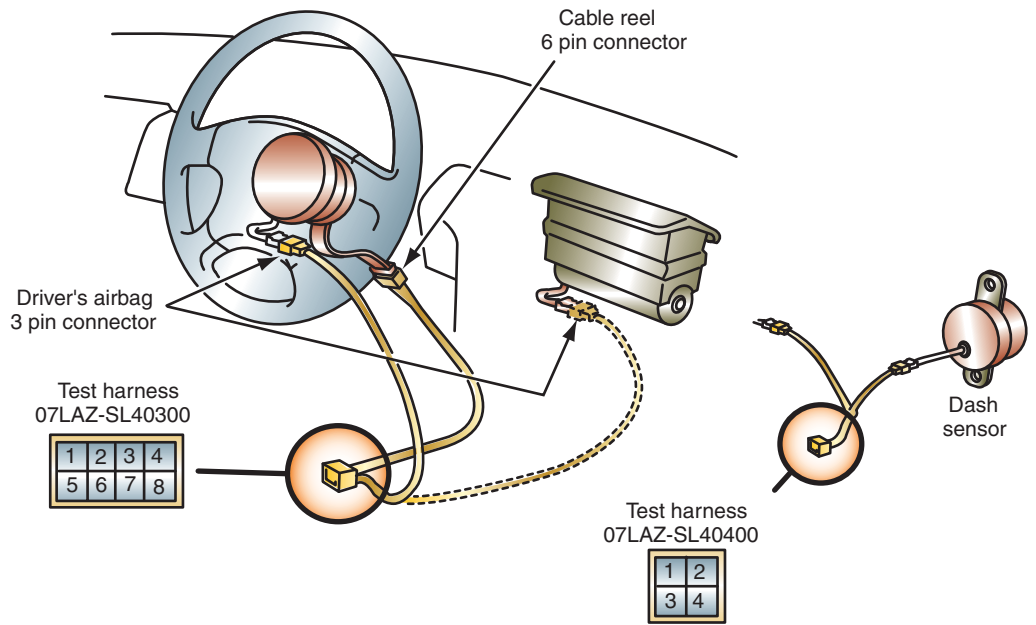


## SPECIAL TOOLS

Air bag load simulator



**FIGURE 15-3** Wiring harness A and B connected at the ASDM terminals.



**FIGURE 15-4** Wiring harness C and D connected at the inflator module and dash sensor terminals.

© Delmar/Cengage Learning



**FIGURE 15-5** Air bag simulator.

© Delmar/Cengage Learning



problems. If a circuit problem does exist that would potentially cause the air bag to deploy, the simulator will indicate it and will remain in that mode until the problem is fixed.

If an active code goes stored after the simulator is installed, the problem is with the disconnected component. For example, if there is an active DTC for “Driver’s side squib circuit open,” but when the air bag module is removed and the simulator installed in its place the DTC becomes stored, then the open is within the air bag module.



**WARNING:** Never attempt to measure the resistance of an air bag module, deployment may occur.



**WARNING:** Never attempt to repair an air bag module.

## INSPECTION AFTER AN ACCIDENT

Any time the vehicle is involved in an accident, even if the air bag was not deployed, all air bag system components should be inspected. The wiring harness must be inspected for damage and repaired or replaced as needed. Any damaged or dented components must also be replaced. Do not attempt to repair any of the sensors or modules. Service is by replacement only.

In the event of deployment, the service information will provide a list of components that must be replaced. The list of components will vary depending on manufacturer.

## CLEANUP PROCEDURE AFTER DEPLOYMENT

If the air bag has been deployed, the residue inside the passenger compartment must be removed before entering the vehicle. Tape the air bag exhaust vents closed to prevent additional powder from escaping. Use the shop vacuum cleaner to remove any powder from the vehicle’s interior. Work from the outside to the center of the vehicle. Vacuum the heater and A/C vents. Run the heater fan blower motor on low speed and vacuum any powder that is blown from the plenum.

## COMPONENT REPLACEMENT

None of the sensors, air bag modules, or controllers used in the air bag system are repairable. In addition, seat belt pretensioners are not serviceable. If any of these components are found to be defective, then the component must be replaced.

If wiring repair is required, first refer to the proper service information. Some manufacturers do not recommend wire harness repair and others may have very specific procedures they require.

## Module Replacement



**WARNING:** Before replacing any component of the air bag system, follow the service information procedure for disarming the system—even if the air bag is deployed.



**WARNING:** Wear safety glasses when working on the air bag system.

### Classroom Manual

Chapter 15, page 444



### SPECIAL TOOLS

- Safety glasses
- Particle dust mask
- Protective clothing with long sleeves
- Tape
- Shop vacuum cleaner

### Classroom Manual

Chapter 15, page 438



### SERVICE TIP:

Anytime the steering column is to be removed from the vehicle, either remove the clockspring or lock the steering wheel so it cannot rotate. This will prevent the clockspring from being accidentally extended beyond its travel limits.

### Classroom Manual

Chapter 15, page 440



### SPECIAL TOOLS

Steering wheel puller set

Follow Photo Sequence 29 as a guide to replacement of an air bag module. When removing the air bag module, the clockspring should be maintained in its correct index position at all times. Failure to do so can cause damage to the enclosure, wiring, or module. Any of these situations can cause the air bag system to default into a nonoperative mode. Always follow the service information for the vehicle you are working on.

The module bolts must be torqued to the specific value. Usually, new bolts are supplied with the air bag module.

Reverse the procedure to reinstall the module. To rearm the system, connect the yellow two-way electrical connector at the base of the steering wheel and install the CPA. Turn the ignition switch to the RUN position; then replace the SRS fuse and connect the battery. This procedure is done to keep the technician out of the vehicle when the system is powered up.

With the ignition switch in the RUN position, observe the SRS warning light. It should perform its bulb test and then shut off. Perform the SRS diagnostic system check to confirm proper operation.

## Clockspring Replacement

The clockspring (Figure 15-6) should be inspected any time the vehicle has been involved in an accident, even if the air bag was not deployed. In addition, the heat generated when an air bag is deployed may damage the clockspring. For this reason, it should be replaced whenever the air bag is deployed. Exact procedures vary according to manufacturer.



**WARNING:** Wear safety glasses when servicing the air bag system.

In most cases (but not all), the front wheels must be located into the straight ahead position. Once the air bag system has been properly disarmed, the air bag module is removed. Mark the steering shaft and steering wheel with index marks for installation. In most cases, the steering wheel will need to be pulled off with a special puller after the lock nut is removed (Figure 15-7).

Once the upper and lower steering column shrouds are removed, the lower clock spring connector can be disconnected. If the clockspring is to be reused, tape it to prevent rotation. Remove the retaining fasteners and the clockspring.



© Delmar/Cengage Learning

FIGURE 15-6 Clockspring.

## TYPICAL PROCEDURE FOR REMOVING THE AIR BAG MODULE

All photos in this sequence are © Delmar/Cengage Learning.



**P29-1** Tools required to remove the air bag module include safety glasses, seat covers, screw driver set, torx driver set battery terminal pullers, battery pliers assorted wrenches, ratchet and socket set, and service information.



**P29-2** Place the seat and fender covers on the vehicle.



**P29-3** Place the front wheels in the straight ahead position and turn the ignition switch to the lock position.



**P29-4** Disconnect the negative battery cable.



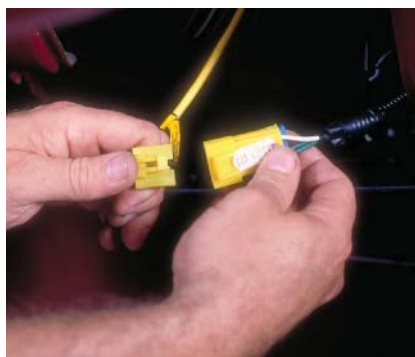
**P29-5** Tape the cable terminal to prevent accidental connection with the battery post. Note: A piece of rubber hose can be substituted for the tape.



**P29-6** Remove the SIR fuse from the fuse box. Wait 10 minutes to allow the reserve energy to dissipate.



**P29-7** Remove the Connector Position Assurance (CPA) from the yellow electrical connector at the base of the steering column.



**P29-8** Disconnect the yellow two-way electrical connector.



**P29-9** Remove the four bolts that secure the module from the rear of the steering wheel.



## PHOTO SEQUENCE 29 (CONTINUED)



**P29-10** Rotate the horn lead 1/4 turn and disconnect it.



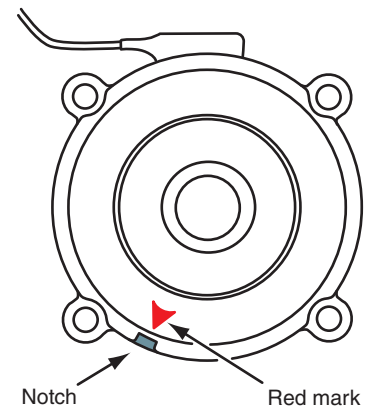
**P29-11** Disconnect the electrical connectors.



**P29-12** Remove the module.



**FIGURE 15-7** Removing the steering wheel may require a puller.



**FIGURE 15-8** The index marks should align if the clockspring is properly centered.

Replacement of the clockspring is done in the reverse order. Some replacement clocksprings will have a locking insert to prevent rotation of the rotor. Do not remove this insert until the clockspring is secured onto the column by the retaining screws. If the clockspring has been moved for some reason, then it must be re-centered. Usually this is done by gently rotating the rotor in one direction. Do not use excessive force, or damage to the clockspring may occur. Once the clockspring is in this full stop position, rotate the rotor in the opposite direction while counting the turns until the other stop is reached. Next rotate the rotor half the number of turns back to the middle of its travel. At this time, some form of index mark (Figure 15-8) or tabs should be aligned. Torque the new steering wheel attaching nut to specifications. When the steering wheel is replaced, rearm the system and perform the verification test.

## OCCUPANT CLASSIFICATION SYSTEM SERVICE

Diagnosing the electrical functions of the occupant classification system (OCS) is performed using a scan tool. DTCs will be recorded any time a fault is detected in the system. In addition, if a fault is detected, the passenger air bag disable lamp (PADL) will turn on, indicating to the driver that the air bags have been suppressed.

Bladder-type systems produced by Delphi have some unique service requirements. If diagnostics indicate that the occupant classification module (OCM) requires replacement, this is only possible if the original seat is in the vehicle. Since the ORC stores the aging calibrations of the seat, if a new OCM is installed, the ORC will recognize the new module and will continue to use the old seat wear calibrations.

If diagnostics of a bladder-type system lead the technician to replace any of the following items, an **OCS service kit** must be installed (Figure 15-9):

- Bladder
- Sensor
- Seat foam
- Cloth seat cover

The OCS service kit consists of the seat foam, the bladder, the pressure sensor, the occupant classification module (OCM), and the wiring. The service kit is calibrated as an assembly. The service kit OCM has a special identification data bit that is transmitted once it is connected. When the service kit is installed, the ORC will identify the service kit OCM and will clear all calibration data related to the system components.

The wiring of the service kit is hot glued to the module and the sensor to prevent separation of the components. A tag also may be located on the wiring harness, which identifies it as a service kit.

The service kit wiring uses a single connector that mates to the existing vehicle wiring harness. The connection on the vehicle harness that originally connected to the OCM now connects to the service kit harness. The connector on the vehicle harness that originally connected in to the pressure sensor will not be used with the service kit. Tie this wire to the harness to prevent it from getting caught in the seat tracks as the seat is moved.

Strain gauge systems by TRW do not have these service requirements. However, any time a component is replaced on either system, the system must be validated before the vehicle is returned to the owner.

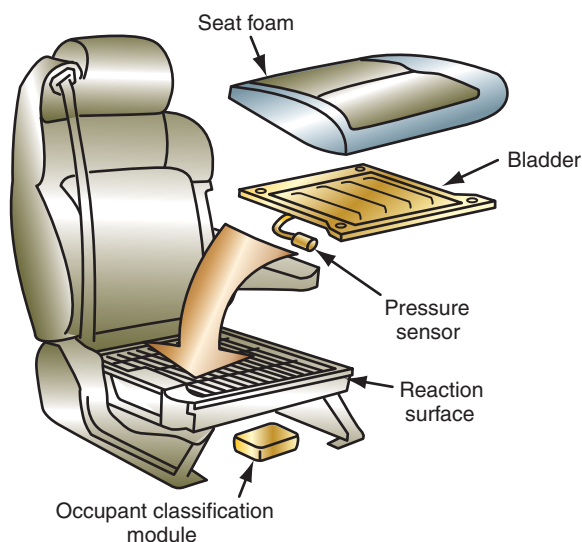
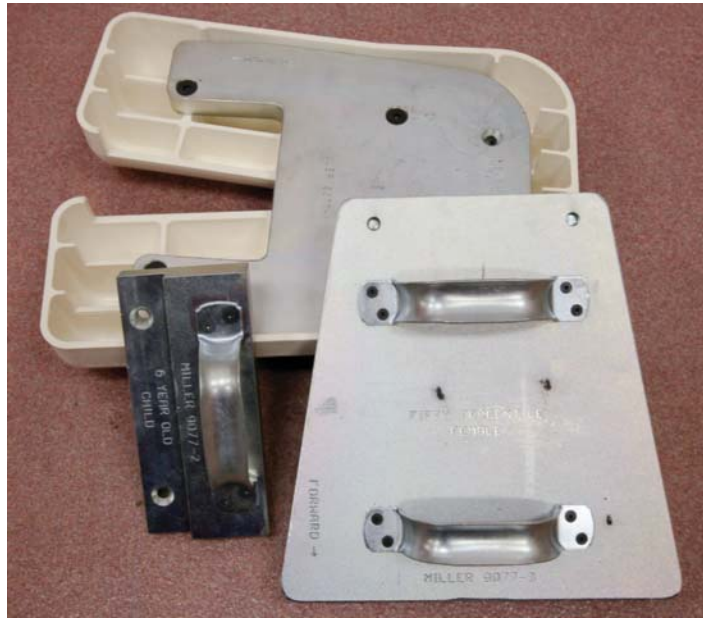


FIGURE 15-9 The OCS service fit.



### CAUTION:

Since the ORC stores the seat-aging calibrations, swapping seats is not a good practice. The ORC will not have the correct calibrations for the replacement seat and the system will not work as intended. This may lead to air bag deployment when an infant is in the seat.



© Delmar/Cengage Learning

FIGURE 15-10 Special OCS weights used to validate the system.



## SPECIAL TOOLS

Validation weight set  
Scan tool



## CAUTION:

If the seat requires removal from the vehicle, the strain gauges are susceptible to damage. Do not drop the seat or allow anyone to sit in it while it is out of the vehicle.

## Classroom Manual

Chapter 15, page 455

## OCS Validation

Whenever the passenger-side front-seat retaining bolts are loosened, the seat is removed from the vehicle, the seat is replaced, the seat trim is replaced, a sensor is replaced, or the OCM is replaced an **OCS validation test** must be performed. Virtually any service that is done to the passenger-side front seat will require the technician to validate OCS. The OCS validation test is done to confirm that the system can properly classify the occupant. This task usually requires the use of special weights (Figure 15-10).

The special weight set has three parts. The tool approximates federal standards for the weight of occupants:

1. The base weight of the tool weighs 37 lbs. (17 kg) to validate for the classification of a rear-facing infant seat (RFIS) weight.
2. The addition of the 10-pound (4.5-kg) weight to the base validates for the weight classification of a child.
3. The addition of the 52-pound (24-kg) weight to the assembly validates for the weight classification of the fifth percentile female.

The total weight of the tool is 99 pounds (45 kg). Weights are added to the base in the proper order and placed in the correct position with the dowel pins. There are differences between the bladder-type and strain gauge-type systems that affect which weights will be used. It is imperative that the correct procedure be followed.

Photo Sequence 30 illustrates a typical procedure for validating the OCS.

## Belt Tension Sensor Diagnostic Test

The following is a typical procedure for testing the belt tension sensor (BTS) used on the Delphi bladder OCS. Since this sensor is used to determine if an infant seat is installed in the front passenger-side seat, it is critical that proper diagnostics be followed. Always refer to the service information for the vehicle you are working on.

With the scan tool connected, monitor the output of the BTS. This will usually be listed in counts (Figure 15-11). With the front passenger-side seat unoccupied and the BTS in its static state, the counts should be between 39 and 69. If the counts are outside of this range, the seat belt retractor and the BTS assembly must be replaced.



## OCCUPANT CLASSIFICATION VALIDATION

All photos in this sequence are © Delmar/Cengage Learning.



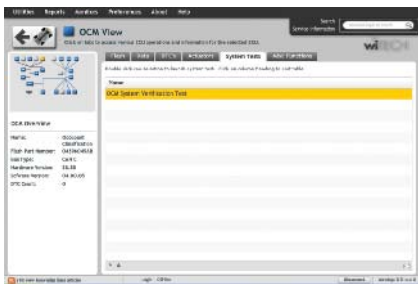
**P30-1** Tools required to perform this task include a scan tool and special verification weights.



**P30-2** Connect the scan tool and check for active battery voltage, OCM internal failure, or communication DTCs. Correct any of these conditions before continuing.



**P30-3** Make sure the seat is empty and is in its full rearward position, with the back rest in a normal upright position.



**P30-4** Use the scan tool to access the "OCM Verification" screen and follow the instructions to begin the test.



**P30-5** Once the test has been started verify that the PADL is illuminated.



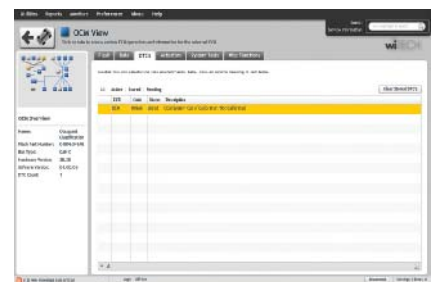
**P30-6** When instructed, add the correct weight amount to the seat. Follow the scan tool prompts to complete this phase of the process. The scan tool should confirm the phase was completed successfully.



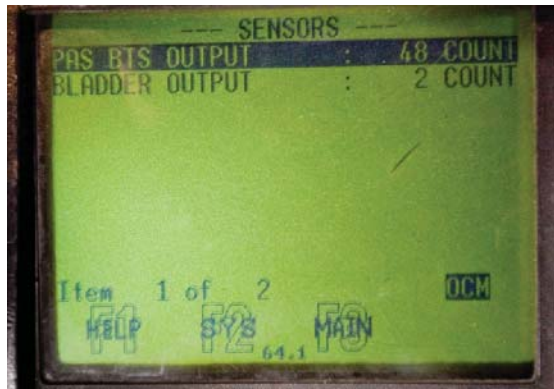
**P30-7** When instructed, add the additional weight and follow the prompts to complete this phase. The scan tool should confirm the phase was completed successfully.



**P30-8** Confirm that the PADL is now off.



**P30-9** Use the scan tool to access DTCs and check for any active codes. If active codes are present, this condition must be repaired and the system verification procedure repeated. Clear any stored codes.



© Delmar/Cengage Learning

**FIGURE 15-11** Scan tool will show the BTS counts.



© Delmar/Cengage Learning

**FIGURE 15-12** Using the pull scale to obtain pressure against the BTS.



### SPECIAL TOOLS

Scan tool  
Pull scale

If the counts are within specified range, use a pull scale (Figure 15-12) to apply a load to the BTS. Connect the hook of the scale through the BTS webbing loop. Grab the pull handle at the top of the spring scale and pull the spring scale straight up, keeping the horizontal bar level with the door sill and the spring scale in line with the BTS. Apply and hold 25 pounds (11.5 kg) of pressure on the sensor while monitoring the BTS counts on the scan tool. The counts should increase to between 153 and 204. If the counts are not within this range, replace the passenger seat belt retractor and BTS assembly.

If the counts are within range, release the pressure applied with the pull scale and monitor the BTS counts again. With no load applied to the BTS, the output should return to between 39 and 69 counts within 20 seconds. If the counts are not within this range, replace the passenger seat belt retractor and BTS assembly.

If the above tests all pass, then the BTS is operating as intended. Confirm all electrical connections before returning the vehicle to the customer.

## CASE STUDY

A customer brings her vehicle to the repair shop because she has observed that the air bag warning light is always illuminated. The technician confirms the warning lamp operation by performing the diagnostic system check. Next, the technician uses the scan tool to retrieve fault codes. The scan tool displays a current code for an open driver's-side air bag squib circuit. Following the service information procedure, the technician removes the air bag module and tests the clockspring circuit. Since the clockspring

circuit proves to be in good condition, the technician replaces the air bag module. Upon completion of installing the new module, the diagnostic system test is run again to confirm the repair was successful. The air bag module was replaced due to the process of elimination. Since the clockspring circuit proved to be good, the air bag module had to be faulty. The resistance of the squib in the module was not tested because this can cause the air bag to deploy and the service information provided several warnings against it.

### TERMS TO KNOW

Automatic seat belt system  
Live module  
OCS validation test  
OCS service kit

## ASE-STYLE REVIEW QUESTIONS

- The occupant classification system must be validated whenever:
  - The seat has been removed from the vehicle.
  - The OCM has been replaced.
  - A new sensor has been installed.
  - All of the above.
- The bladder system service kit is required if any of the following requires replacement EXCEPT:
  - The bladder.
  - The BTS.
  - The pressure sensor.
  - The cushion.
- The PADL is off when the seat is empty. This may indicate:
  - A faulty OCM.
  - Normal operation.
  - The BTS is indicating the seat belt is cinched.
  - All of the above.
- Replacement of an air bag module is being discussed. *Technician A* says to follow the service information procedure for disarming the system. *Technician B* says to wear safety glasses. Who is correct?
  - A only
  - B only
  - Both A and B
  - Neither A nor B
- Technician A* says the clockspring should be inspected any time the vehicle has been involved in an accident, even if the air bag was not deployed. *Technician B* says the heat that is generated when an air bag is deployed may damage the clockspring. Who is correct?
  - A only
  - B only
  - Both A and B
  - Neither A nor B
- Technician A* says air bag residue should be swept from the vehicle's interior using a whisk broom. *Technician B* says whenever a vehicle is involved in an accident the air bag control module must be replaced. Who is correct?
  - A only
  - B only
  - Both A and B
  - Neither A nor B
- Air bag system service is being discussed. *Technician A* says before an air bag system component is replaced, the negative battery cable should be disconnected and the technician should wait the specified time advised in the service information. *Technician B* says this waiting period is necessary to dissipate the reserve energy in the air bag system computer. Who is correct?
  - A only
  - B only
  - Both A and B
  - Neither A nor B
- Air bag sensor service is being discussed. *Technician A* says incorrect torque on air bag sensor fasteners may cause improper air bag deployment. *Technician B* says the arrow on an air bag sensor must face toward the driver's side of the vehicle. Who is correct?
  - A only
  - B only
  - Both A and B
  - Neither A nor B
- Air bag system diagnosis is being discussed. *Technician A* says on some Ford products, the air bag computer prioritizes faults and flashes the code representing the highest priority fault. *Technician B* says on some air bag systems, the air bag computer disarms the system if a fault occurs that could result in an unwarranted air bag deployment. Who is correct?
  - A only
  - B only
  - Both A and B
  - Neither A nor B
- The purpose of the air bag load tool is being discussed. *Technician A* says the load tool is used to load the air bag system circuits to prevent accidental deployment. *Technician B* says the load tool is used to simulate known good resistances of the circuit. Who is correct?
  - A only
  - B only
  - Both A and B
  - Neither A nor B

## ASE CHALLENGE QUESTIONS

---

1. A customer states that the “Pass Air bag off” light comes on whenever they lay their briefcase on the front passenger seat.  
*Technician A* says the OCS is too sensitive and needs to be validated.  
*Technician B* says this is normal since the weight of the briefcase is matching the weight of a small child.  
Who is correct?

A. A only            C. Both A and B  
B. B only            D. Neither A nor B
2. The customer is concerned about the “Pass Air Bag Off” light not illuminating when their eight-year-old child sits on the seat. The vehicle is equipped with a bladder-type system.  
*Technician A* says this is normal operation.  
*Technician B* says a DTC will set for this condition.  
Who is correct?

A. A only            C. Both A and B  
B. B only            D. Neither A nor B
3. A customer states that while driving the vehicle, the air bag warning lamp illuminates intermittently.  
*Technician A* says this can be caused by a loose connection to one of the system’s sensors.  
*Technician B* says this may indicate a defect that will set a trouble code.  
Who is correct?

A. A only            C. Both A and B  
B. B only            D. Neither A nor B
4. Passenger-side air bag deactivation is being discussed.  
*Technician A* says if the vehicle is not equipped with a factory installed ON/OFF switch, disconnect the connector to the air bag module and remove the air bag warning lamp.  
*Technician B* says the vehicle owner must provide a letter of approval from the NHTSA before a deactivation kit can be installed.  
Who is correct?

A. A only            C. Both A and B  
B. B only            D. Neither A nor B
5. Side-impact air bags are being discussed.  
*Technician A* says most systems have a control module or sensor located in the B pillar.  
*Technician B* says the side air bags only deploy when the front air bags deploy.  
Who is correct?

A. A only            C. Both A and B  
B. B only            D. Neither A nor B

Name \_\_\_\_\_ Date \_\_\_\_\_

## WORKING SAFELY AROUND AIR BAGS

Upon completion of this job sheet, you should be able to work safely around and with air bag systems.

### ASE Correlation

This job sheet is related to the ASE Electrical/Electronic System Certification Exam's content area: *Miscellaneous*; task: Inspect, test, and repair or replace the air bag, air bag module, sensors, connectors, and wires of the air bag system circuit(s).

### Tools and Materials

- A vehicle with air bags
- Service information for the chosen vehicle
- Component locator for the chosen vehicle
- Safety glasses
- A DMM

### Describe the vehicle being worked on:

Year \_\_\_\_\_ Make \_\_\_\_\_ Model \_\_\_\_\_  
 VIN \_\_\_\_\_ Engine type and size \_\_\_\_\_

### Procedure

Task Completed \_\_\_\_\_

1. Locate the information about the air bag system in the service information. How are the critical parts of the system identified in the vehicle?

---

---

---

---

---

---

---

---

2. List the main components of the air bag system and describe their locations.

---

---

---

---

---

---

---

---

3. There are some very important guidelines to follow when working with and around air bag systems. These are listed below with some key words left out. Read through these and fill in the blanks with the correct words.
- a. Wear \_\_\_\_\_ when servicing an air bag system and when handling an air bag module.
  - b. Wait at least \_\_\_\_\_ minutes after disconnecting the battery before beginning any service. The reserve \_\_\_\_\_ module is capable of storing enough energy to deploy the air bag for up to \_\_\_\_\_ minutes after battery voltage is lost.
  - c. Always handle all \_\_\_\_\_ and other components with extreme care. Never strike or jar a sensor, especially when the battery is connected; this can cause deployment of the air bag.
  - d. Never carry an air bag module by its \_\_\_\_\_ or \_\_\_\_\_, and, when carrying it, always face the trim and air bag \_\_\_\_\_ from your body. When placing a module on a bench, always face the trim and air bag.
  - e. \_\_\_\_\_ air bags may have a powdery residue on them. \_\_\_\_\_ is produced by the deployment reaction and is converted to \_\_\_\_\_ when it comes in contact with the moisture in the atmosphere. Although it is unlikely that harmful chemicals will still be on the bag, it is wise to wear \_\_\_\_\_ and \_\_\_\_\_ when handling a deployed air bag. Wash your hands immediately after handling a deployed air bag.
  - f. A live air bag must be \_\_\_\_\_ before it is disposed of. A deployed air bag should be disposed of in a manner consistent with the \_\_\_\_\_ and the manufacturer's recommended procedures.
  - g. Never use a battery- or AC-powered \_\_\_\_\_, \_\_\_\_\_, or any other type of test equipment in the system unless the manufacturer specifically says to. Never probe with a \_\_\_\_\_ for voltage.

Instructor's Response \_\_\_\_\_  
\_\_\_\_\_  
\_\_\_\_\_



Name \_\_\_\_\_ Date \_\_\_\_\_

## DIAGNOSING “DRIVER SQUIB CIRCUIT OPEN” FAULT

Upon completion of this job sheet, you should be able to diagnose the cause of a “driver squib circuit open” fault in an air bag system and determine needed repairs.

### ASE Correlation

This job sheet is related to the ASE Electrical/Electronic System Certification Exam’s content area: *Miscellaneous*; task: Inspect, test, and repair or replace the air bag, air bag module, sensors, connectors, and wires of the air bag system circuit(s).

### Tools and Materials

A vehicle equipped with a driver’s-side air bag (bugged by instructor prior to performing this task)

Service information for chosen vehicle

Safety glasses

Battery terminal puller

Jumper wires

Scan tester

### Describe the vehicle being worked on:

Year \_\_\_\_\_ Make \_\_\_\_\_ Model \_\_\_\_\_

VIN \_\_\_\_\_ Engine type and size \_\_\_\_\_

### Procedure

\_\_\_\_\_  
Task Completed

1. Describe the normal conditions in which the air bag warning lamp should operate.

\_\_\_\_\_  
\_\_\_\_\_  
\_\_\_\_\_

2. Perform the diagnostic system check. How did the air bag warning light respond?

\_\_\_\_\_  
\_\_\_\_\_

3. Follow all safety warnings and cautions listed in the service information and connect the scan tool. Record all fault codes the scan tool displays.

Active: \_\_\_\_\_

Stored: \_\_\_\_\_

\_\_\_\_\_

**Task Completed**

4. Is the code for “Driver-Side Squib Circuit” or equivalent active?  Yes  No  
If no, consult your instructor.

5. List all possible causes that can set this fault code.

---

---

---

6. Disconnect the negative battery cable and isolate it.

7. How long does the service information say you must wait before proceeding?

---

---

8. Follow the service information instructions to remove the driver’s-side air bag module from the steering wheel.

9. Connect a jumper wire across the upper connector of the clockspring.

10. With the ignition switch in the RUN position, connect the battery ground cable.

11. Use the scan tool and record the active fault code.

---

---

12. Does the fault code indicate the circuit is shorted?  Yes  No

13. If you answered yes to question 12, what is the faulty component?

---

---

14. If you answered no to question 12, locate the lower clockspring connector. Describe this connector’s location.

---

---

---

15. Disconnect the negative battery cable and isolate it. Wait the recommended amount of time before proceeding.

16. Disconnect the lower clockspring connector and connect a jumper wire across the control module side of the harness connector.

17. With the ignition switch in the RUN position, reconnect the battery ground cable.

18. Use the scan tool to retrieve active fault codes and record them.

---

19. Does the fault code indicate the circuit is shorted?  Yes  No

20. If you answered yes to question 19, what is the faulty component?

---

21. If you answered no to question 19, locate the connector to the air bag control module. Describe this connector's location.

---

---

---

22. Disconnect the negative battery cable and isolate it. Wait the recommended amount of time before proceeding.



23. Disconnect the air bag control module connector and locate the wires of the driver-side squib circuit. What are the color codes of the wires?

---

---

---

24. Use an ohmmeter to test the wire harness between the air bag control module connector and the lower clockspring connector. Record your results.

---

---

25. Based on your results, what have you determined to be the location of the fault?

---

---

Instructor's Response \_\_\_\_\_

---

---

*This page intentionally left blank*

Name \_\_\_\_\_ Date \_\_\_\_\_

## CLOCKSPRING REPLACEMENT AND CENTERING

Upon completion of this job sheet, you should be able to remove, replace, and properly center the clockspring used in an air bag system.

### ASE Correlation

This job sheet is related to the ASE Electrical/Electronic System Certification Exam's content area: *Miscellaneous*; task: Inspect, test, and repair or replace the air bag, air bag module, sensors, connectors, and wires of the air bag system circuit(s).

### Tools and Materials

- A vehicle equipped with a driver's-side air bag
- Service information for chosen vehicle
- Safety glasses
- Battery terminal puller
- Steering wheel puller

### Describe the vehicle being worked on:

Year \_\_\_\_\_ Make \_\_\_\_\_ Model \_\_\_\_\_  
 VIN \_\_\_\_\_ Engine type and size \_\_\_\_\_

### Procedure

Task Completed

1. According to the service information, in what position must the front wheels be before beginning?  
 \_\_\_\_\_  
 \_\_\_\_\_
2. Place the front wheels in the position described in step 1.
3. Disconnect the battery negative cable and isolate it.
4. According to the service information, how long must you wait before proceeding?  
 \_\_\_\_\_  
 \_\_\_\_\_
5. Remove the air bag module from the steering wheel.
6. Remove the steering wheel attaching bolt or nut. Can this fastener be reused?  
 Yes    No
7. Mark the shaft and steering wheel with index marks for reinstallation.
8. Use a steering wheel puller to remove the steering wheel from the shaft.
9. Remove the upper and lower steering column shrouds.

---

Task Completed

**10.** Disconnect the clockspring connector from the steering column harness.

**11.** Remove the retaining screws (or release the locking tabs) and the clockspring.

**12.** If the same clockspring is to be reinstalled, describe the procedure for centering the clockspring.

---

---

---

**13.** In what position must the front wheel and steering column be to install the clockspring?

---

**14.** Install all components.

What is the torque specification for the clockspring fasteners (if used)?

---

What is the torque specification for the steering wheel fastener?

---

What is the torque specification for the air bag module fasteners?

---

Instructor's Response \_\_\_\_\_

---

---



Name \_\_\_\_\_ Date \_\_\_\_\_

## OCCUPANT CLASSIFICATION SYSTEM VALIDATION PROCEDURE

Upon completion of this job sheet, you should be able to properly perform the OCS validation procedure.

### ASE Correlation

This job sheet is related to the ASE Electrical/Electronic System Certification Exams content area: *Accessories Diagnosis and Repair*; task: Diagnose supplemental restraint system (SRS) concerns, determine necessary action.

### Tools and Materials

- Vehicle with OCS
- Scan tool
- Validation weight set
- Battery charger

### Describe the vehicle being worked on:

Year \_\_\_\_\_ Make \_\_\_\_\_ Model \_\_\_\_\_  
 VIN \_\_\_\_\_ Engine type and size \_\_\_\_\_

### Procedure

Task Completed

1. Connect a battery charger to the vehicle's battery and set so 13.0 volts is read across the terminals.
2. Is the system on the assigned vehicle a strain gauge or bladder system?  
 Strain Gauge     Bladder
3. Connect the scan tool to the DLC and access the occupant classification system module. Provide the following information (if available):  
 OCM part number \_\_\_\_\_  
 Software version \_\_\_\_\_
4. Make sure the passenger front seat is empty. What is the state of the PADL?  
 \_\_\_\_\_
5. Sit in the seat and describe the state of the PADL.  
 \_\_\_\_\_
6. Use the scan tool to access the sensor display function. Record the values while remaining in the seat.  
 \_\_\_\_\_  
 \_\_\_\_\_

**Task Completed**

7. Move out of the seat and record the values.

---

---

8. Assure that the seat is empty and navigate the scan tool to the validation function. What instructions are provided on the scan tool screen when the test is started (if any):

---

---

---

9. According to the scan tool, what is the first step that needs to be performed?

---

---

10. What is the first weight amount to be placed on the seat?

---

11. During the validation procedure, what is the state of the PADL?

---

---

12. Complete the validation procedure while listing the required weight amounts.

---

---

---

13. How do you know the procedure was completed?

---

14. What is the state of the PADL once the procedure is completed? \_\_\_\_\_

15. Clear any DTCs that may have been set.

16. Disconnect a sensor and record any DTCs.

---

---

17. Reconnect the sensor. Did the fault go from active to stored? \_\_\_\_\_

18. What needs to be done to clear the DTC?

---

19. Perform the required task list in step 18.

Instructor's Response \_\_\_\_\_

---

---

<b>DIAGNOSTIC CHART 15-1</b>	
PROBLEM AREA:	Air bag system operation.
SYMPTOMS:	Air bag warning lamp illuminated.
POSSIBLE CAUSES:	<ol style="list-style-type: none"><li>1. Squib circuit shorted to ground.</li><li>2. Defective clockspring.</li><li>3. Squib circuit open.</li><li>4. Sensor circuit open.</li><li>5. Sensor circuit shorted.</li><li>6. Faulty module.</li><li>7. Poor battery feed circuit to control module.</li><li>8. Poor ignition feed circuit to control module.</li><li>9. Poor control module ground circuit.</li><li>10. Loss of bus communications.</li><li>11. Faulty instrument cluster lamp circuit.</li></ol>

*This page intentionally left blank*

# HYBRID AND HIGH-VOLTAGE SYSTEM SERVICE



### BASIC TOOLS

- Basic mechanic's tool set
- Fender covers
- Safety glasses
- Insulating gloves

### UPON COMPLETION AND REVIEW OF THIS CHAPTER, YOU SHOULD BE ABLE TO:

- Demonstrate proper safety precautions associated with servicing the hybrid electric vehicle.
- Properly remove and install the high-voltage service plug.
- Access and interpret DTCs, information codes, freeze frame data, and history data.
- Determine the cause of HV battery system failures.
- Determine failures of the inverter/converter assembly.
- Determine the cause of system main relay failures.
- Replace the system main relays.

### INTRODUCTION

This chapter discusses some of the service procedures for a common hybrid system. At the present time, specially trained dealership technicians perform most of the service of the hybrid system. Because of this, the main focus of this chapter will be on safety concerns associated with the high-voltage system.

The hybrid electric vehicle (HEV) system combines the operating characteristics of an internal combustion engine and an electric motor. In addition, the system can use regenerative braking to recover energy that normally would be lost to heat and use it to supplement the power of the engine. The sample HEV used to describe the service procedures in this chapter includes the following components (Figure 16-1):

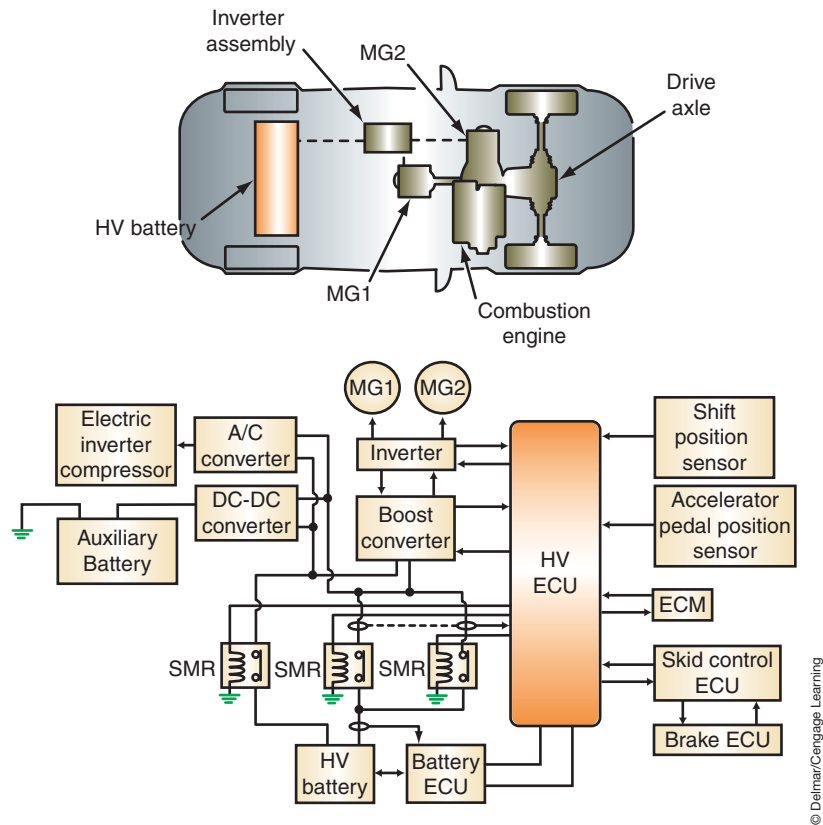
- Hybrid transaxle that integrates the MG1, the MG2, and the planetary gear unit.
- Inverter assembly.
- HV ECU.
- ECM.
- HV battery.
- Battery ECU.
- Service plug.
- The system main relay (SMR).
- Auxiliary battery.

### SAFETY PRECAUTIONS

Since the hybrid system can use voltages in excess of 500 volts (both DC and AC), it is vital that the service technician be familiar with, and follow, all safety precautions. Failure to perform the correct procedures can result in electrical shock, battery leakage, or an explosion.

**Classroom  
Manual**

Chapter 16, page 465



**FIGURE 16-1** Components of an HEV system.

The following are the safety procedures that must be followed whenever servicing the HEV's high-voltage systems:

- Remove the key from the ignition.
- Disconnect the negative (-) terminal of the auxiliary (12-volt) battery. Always disconnect the auxiliary battery prior to removing the high-voltage service plug.
- Remove the high-voltage service plug and put it where it cannot be accidentally reinstalled by someone else.
- Cover the high-voltage service plug receptacle with insulation tape.
- Do not attempt to test or service the system for five minutes after the high-voltage service plug is removed. At least five minutes is required to discharge the high-voltage condenser inside the inverter.
- Test the integrity of the insulating gloves prior to use.
- Wear high-voltage insulating gloves when disconnecting the service plug.
- Never cut the orange high-voltage power cables. The wire harnesses, terminals, and connectors of the high-voltage system are identified by orange. In addition, high-voltage components may have a "High Voltage" caution label attached to them.
- Cover the terminals of a disconnected connector with insulation tape.
- Never open high-voltage components.
- Use a DMM to confirm that high-voltage circuits have 0 V before performing any service procedure.
- Use insulated tools when available.
- Do not wear metallic objects that may cause electrical shorts.
- Follow the service manual diagnostic procedures.
- Wear protective safety goggles when inspecting the high-voltage (HV) battery.



- Before touching any of the high-voltage system wires or components, wear insulating gloves, make sure the power switch is off, and disconnect the auxiliary battery.
- Turn the power switch to the OFF position prior to performing a resistance check.
- Turn the power switch to the OFF position prior to disconnecting or reconnecting any connectors or components.
- Isolate with insulation tape any high-voltage wires that have been removed.
- Properly torque the high-voltage terminals.



### SPECIAL TOOLS

DMM capable of reading 400 VDC  
 Insulating gloves  
 Insulating tape

## Insulating Glove Integrity Test

The insulating gloves that the technician wears for protection while servicing the high-voltage system must be tested for integrity before use. If there is a leak in the gloves, high-voltage electricity can travel through the hole to the technician's body. To test a glove, blow air into it and then fold it at the base to seal the air inside. Slowly roll the base of the glove toward the fingers. If the glove holds pressure, its insulating properties are intact. If any leaks are detected, discard the glove.



### SERVICE TIP:

DTCs will be erased once the batteries are disconnected. Prior to disconnecting the system, be sure to check and record and DTCs.

## HIGH-VOLTAGE SERVICE PLUG

The HEV is equipped with a **high-voltage service plug** that disconnects the HV battery from the system. Usually, this plug is located near the battery (Figure 16-2). Prior to disconnecting the high-voltage service plug, the vehicle must be turned off and the negative terminal of the auxiliary battery must be disconnected. Once the high-voltage service plug is removed, the high-voltage circuit is shut off at the intermediate position of the HV battery.

The high-voltage service plug assembly contains a safety interlock reed switch. The reed switch is opened when the clip on the high-voltage service plug is lifted. The open reed switch turns off power to the service main relay (SMR). The main fuse for the high-voltage circuit is inside the high-voltage service plug assembly.

However, never assume that the high-voltage circuits are off. The removal of the high-voltage service plug does not disable the individual high-voltage batteries. Use a DMM to verify that 0 volts are in the system before beginning service. When testing the circuit for voltage, set the voltmeter to the 400 VDC scale.

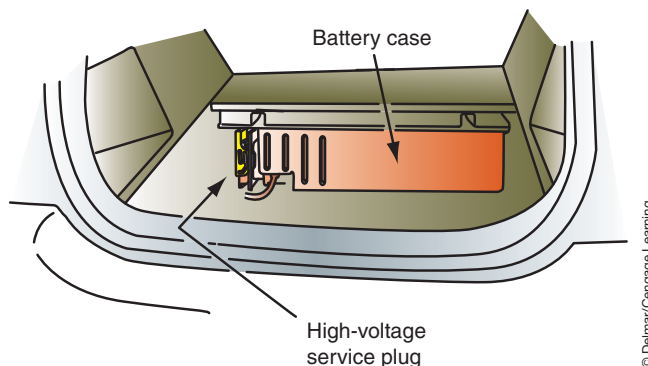
After the high-voltage service plug is removed, a minimum of five minutes must pass before beginning service on the system. This is required to discharge the high voltage from the condenser in the inverter circuit.

To install the high-voltage service plug, make sure the lever is locked in the DOWN position (Figure 16-3). Slide the plug into the receptacle, and lock it in place by lifting the lever upward. Once it is locked in place, it closes the reed switch.

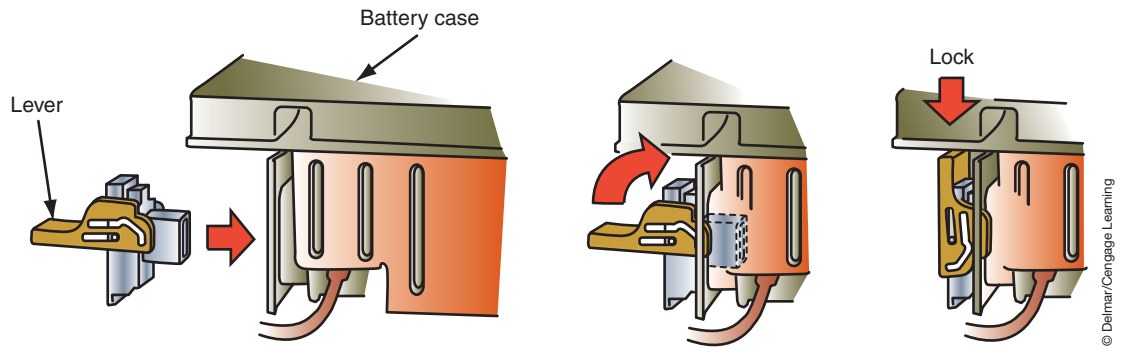


### CAUTION:

Once the high-voltage service plug is removed, do not operate the power switch. Doing so may damage the hybrid vehicle control ECU.



**FIGURE 16-2** The high-voltage service plug is usually located near the HV battery.



**FIGURE 16-3** To install the service plug, make sure the lever is down and then fully locked once installed.

© Delmar/Cengage Learning

### Classroom Manual

Chapter 16, page 466



### SPECIAL TOOLS

Scan tool

The DTCs associated with the HV system may include both SAE codes and manufacturer codes. SAE codes must be set as prescribed by the SAE, while manufacturer codes can be set by a manufacturer.

## SELF-DIAGNOSIS CAPABILITIES

The **high-voltage electronic control unit (HV ECU)** controls the two motor generators (MG1 and MG2) and the engine based on torque demand. Also, these units are controlled based on regenerative brake control and the HV battery's state of charge (SOC). It is the responsibility of the HV ECU to provide reliable circuit shutdown in the event of a malfunction. The HV ECU uses three relays housed in the SMR assembly to connect and disconnect the high-voltage circuit. If a malfunction is detected, the HV ECU will use the relays to control the system based on programmed instructions stored in its memory. If the system is determined to be malfunctioning, the HV ECU will illuminate the master warning lamp in the instrument cluster. In addition, it may illuminate the HV system warning, the HV battery warning, or the discharge warning lamps.

DTCs are set when the fault occurs. To access the DTCs, a scan tool with the proper interface module (if needed) is connected to the data link connector (DLC). The scan tool will also provide information codes, freeze frame data, and history data.

**Information codes** are additional codes that provide more information and freeze frame data concerning the DTCs. Information codes along with the DTC indicate more precisely the location of the fault. These codes are accessed using the scan tool while in the HV ECU system screen (Figure 16-4).

The **freeze frame data** is a recording of the driving condition when the malfunction occurred. This is useful for determining how the vehicle was operating at the time and for locating any input or output values that are out of range.

**History data** information can be useful for determining if a customer's concern is actually a problem with the system. It provides a means of determining if the vehicle owner's driving habits may be the cause of the problem. The data will display information such as if the gear shift lever was moved before the vehicle was ready, if the transmission was shifted into park while the vehicle was moving, if the accelerator pedal was depressed while in the NEUTRAL position, and so on. Use the proper service manual for information on using this data.

**CUSTOMER CARE:** Since the hybrid vehicle is still new on the market, the chances are the vehicle owner has never driven one before. Take the time to explain the proper operation of the vehicle to prevent any misunderstandings of the system function.

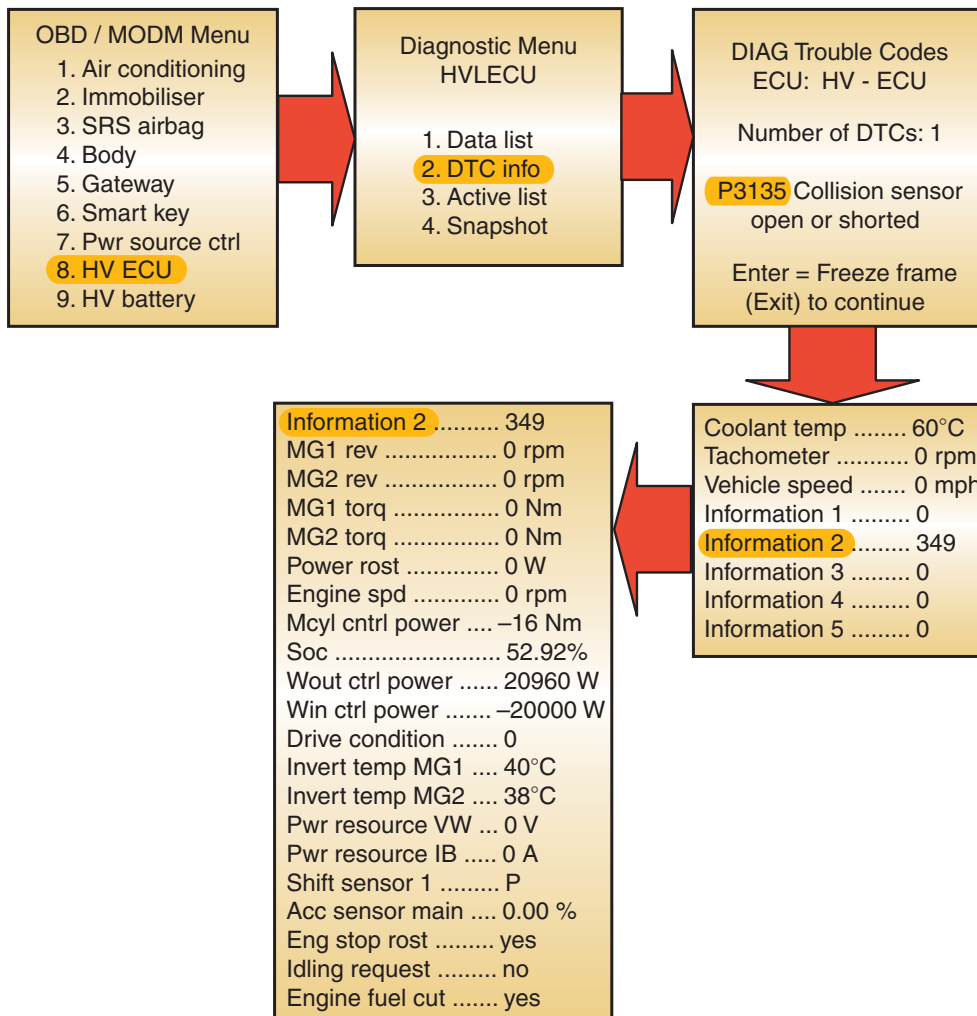


FIGURE 16-4 Accessing information codes.

© Delmar/Cengage Learning

In addition, the scan tool may provide activation tests of the HV ECU. Different tests are available. Using the service manual, determine what test is required for the specific test. The following are typical mode functions:

- Mode 1. This mode runs the engine continuously in the PARK position and to check HV ECU operation. It can also be used to disable traction control so the speedometer test can be performed.
- Mode 2. Cancels the traction control that is affected when the rotational difference between the front and rear wheels is excessive.
- Inverter stop. Keeps the inverter power transistor on to determine if there is an internal leak in the inverter or the HV control ECU.
- Cranking request. Activates the motor generator continuously to crank the engine in order to measure the compression.

## HIGH-VOLTAGE BATTERY SERVICE

A **battery ECU** monitors the condition of the HV battery assembly. The battery ECU determines the SOC of the HV battery by monitoring voltage, current, and temperature. The battery ECU collects data and transmits it to the HV ECU to be used for proper charge and discharge control.

**Classroom Manual**

Chapter 16, page 466



## SPECIAL TOOLS

DMM  
Scan tool

MG1 functions as the control element for the planetary gear set. It recharges the HV battery and supplies electrical power to drive MG2. MG1 also functions as the starter for the engine. MG2 is used for power at low speeds and for supplemental power when needed at higher speeds.

The battery ECU also controls the operation of the battery blower motor to maintain proper HV battery temperature.

The HV battery stores power generated by MG1 and recovered by MG2 during regenerative braking (Figure 16-5). The HV battery must also supply power to the electric motor when the vehicle is first started from a stop or when additional power is needed. A typical HV battery uses several nickel-metal-hydrate modules and can provide over 270 volts (Figure 16-6).

When the vehicle is moving, the HV battery is subjected to repetitive charge and discharge cycles. The HV battery is discharged by MG2 during acceleration mode and then is recharged by regenerative braking. An amperage sensor (Figure 16-7) is used so the battery ECU can transmit requests to the HV ECU to maintain the SOC of the HV battery. The battery ECU attempts to keep the SOS at 60 percent. The battery ECU also monitors delta SOC to determine if it is capable of maintaining acceptable levels of charge. The normal, low-to-high SOC delta is 20 percent.

If the battery ECU sends abnormal messages to the HV ECU, the HV ECU illuminates the warning light and enters fail-safe control. DTCs and informational codes are set along with freeze frame data. Fail-safe can result in the battery ECU restricting or stopping the charging and discharging of the HV battery.

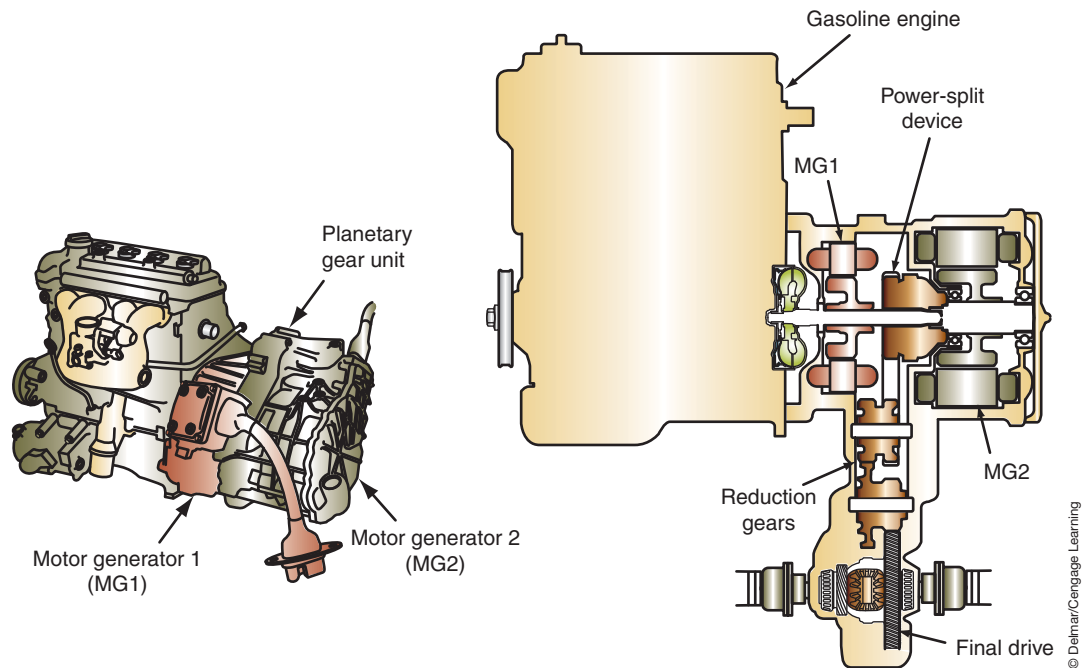


FIGURE 16-5 Layout of the generating HEV transaxle.

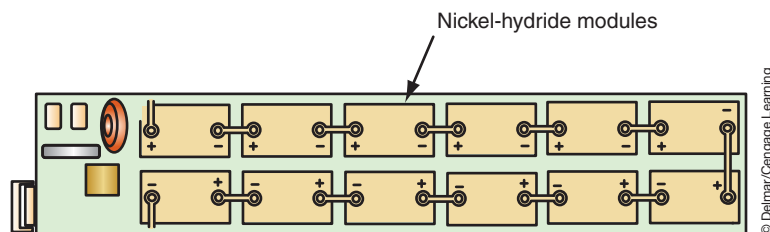
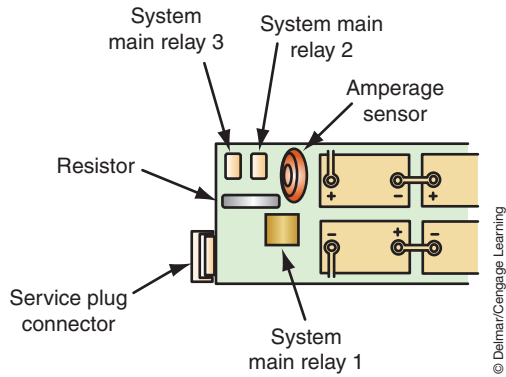


FIGURE 16-6 The HV battery.



**FIGURE 16-7** The battery ECU and amperage sensor.

If there is a leak in the high-voltage system insulation that may seriously harm a person, the system will enter fail-safe control and set DTCs. This will occur if the battery ECU determines the insulation resistance of the power cable is 100kΩ, or less.

Whenever an HV battery malfunction occurs, use the scan tool to view the “HV Battery Data List.” This provides all HV battery system information.

### High-Voltage Battery Charging

If the SOC of the HV battery is too low to allow the engine to run, the HV battery will need to be recharged. This requires the use of a special high-voltage battery charger (Figure 16-8). In addition, most manufacturers will only allow specially trained people to recharge the battery. Some manufacturers will not even supply the charging equipment to the dealer; a representative of the company performs the task of recharging the HV battery.

HV battery recharging must be performed outside. The correct cable is connected between the vehicle and the charger (Figure 16-9). When using the charger, the immediate area must be secured and marked with warning tape. It will require about three hours to recharge the battery to an SOC of about 50 percent.



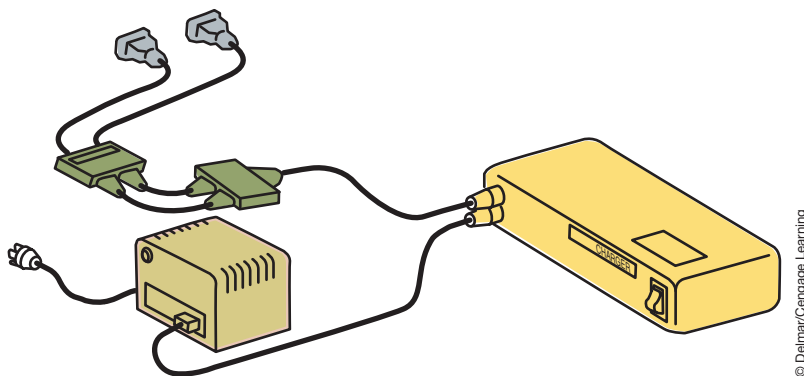
#### SERVICE TIP:

If inspection and testing fail to locate the leak, then it is possible that water entered into the battery assembly or into the converter/inverter assembly.



#### SPECIAL TOOLS

High-voltage battery charger  
Warning tape



**FIGURE 16-8** HV battery charger.

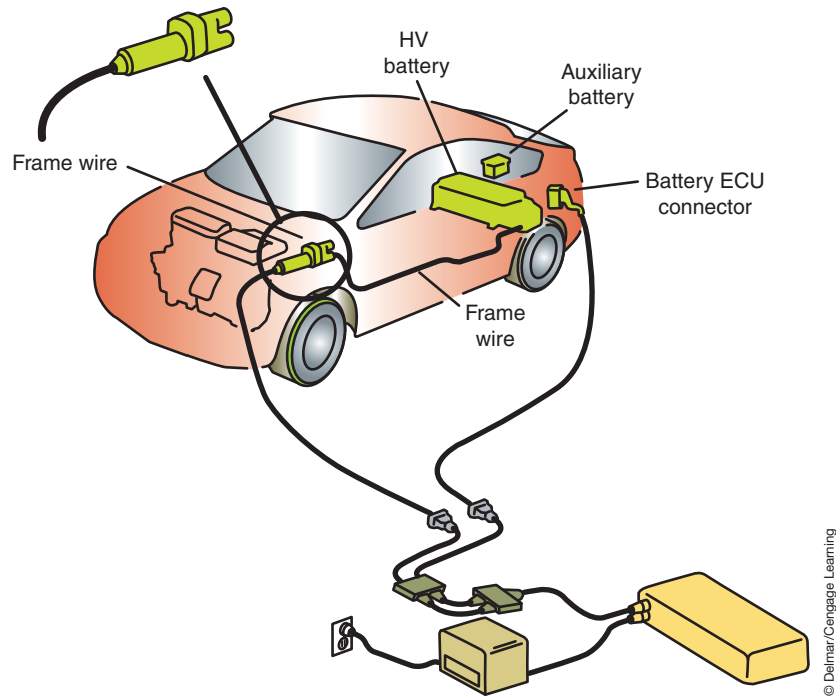


FIGURE 16-9 HV battery charger connection.

## INVERTER/CONVERTER ASSEMBLY

The **inverter** (Figure 16-10) controls the current flow between MG1, MG2, and the HV battery. The inverter converts HV battery DC voltage into three-phase alternating current for MG1 and MG2. It also converts (rectifies) high-voltage AC from MG1 and MG2 to DC voltage to charge the HV battery. The HV ECU controls the activation of the power transistors to perform these functions (Figure 16-11).

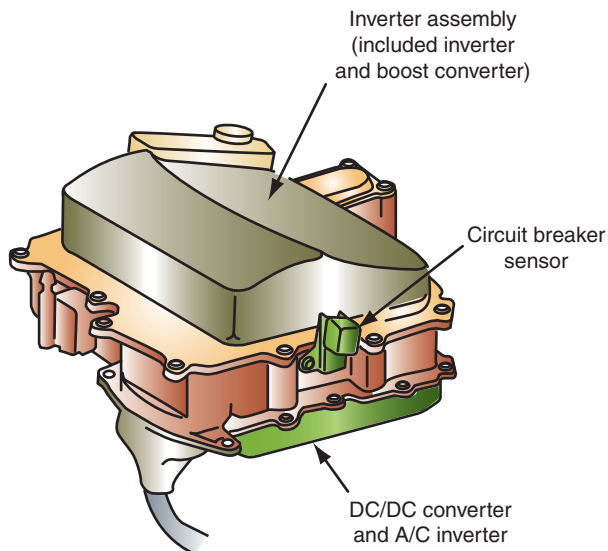


FIGURE 16-10 The inverter.







## SPECIAL TOOLS

Scan tool  
Insulating gloves  
Insulating tape

## SYSTEM MAIN RELAY

The HV ECU controls the operation of the **system main relay (SMR)** to connect and disconnect the power source of the high-voltage system. Three relays are used. One is for the negative side, while the other two are for the positive side (Figure 16-13).

Initially SMR1 and SMR3 are turned on to energize the circuit for the HV battery. This provides the needed current for the motor generator to start the engine. Then SMR2 is energized and SMR1 is turned off. This makes the current from the generator flow through a resistor, thus controlling the amount of current flow. This protects the circuit from excessive initial current from the generator. Finally, SMR2 is turned on and SMR1 is turned off to allow free flow of current in the circuit.

During shutdown, SMR2 is turned off first, then SMR3. This provides a means for the HV ECU to verify that the relays have been properly turned off.

The HV ECU checks that the system main relay is operating normally. If a fault is detected, DTCs and information data will be stored. The following is a typical procedure to be used if diagnosis leads to replacement of one of the SMRs:

1. Secure the proper service manual, tested insulating gloves, and insulating tape.
2. Gain access to the auxiliary battery and disconnect the negative terminal.
3. Wearing the insulated gloves, remove the high-voltage service plug.
4. Use insulating tape to cover the terminals of the plug receptacle.
5. After gaining access to the battery carrier panel, remove the junction terminal. Be sure to wear your insulating gloves.
6. Remove the grandwire, SMR2 cover, and disconnect the relay connector to remove SMR2.
7. Remove SMR3 by disconnecting the main battery cable, disconnecting the connector, and removing the fasteners.
8. Disconnect the connector and the ground terminal for SMR1.
9. Remove the fasteners and remove SMR1.

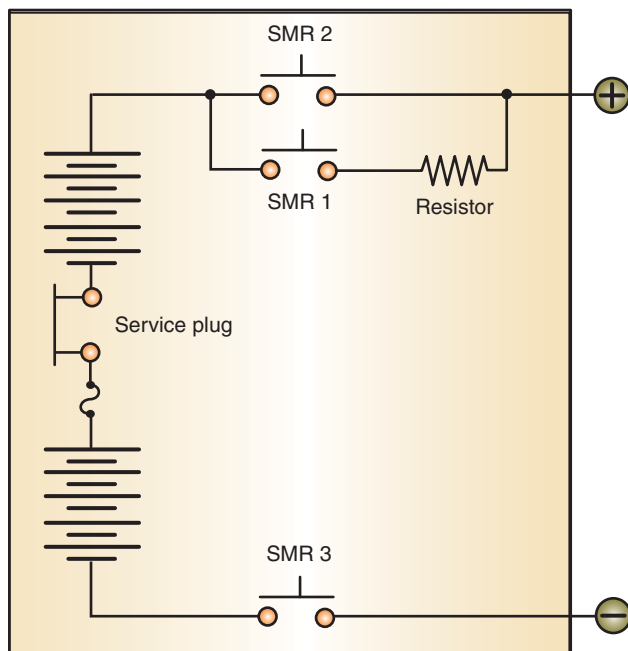


FIGURE 16-13 Schematic of the SMR.

© Delmar/Cengage Learning

## TERMS TO KNOW

Battery ECU  
Converter  
Freeze frame data  
High-voltage electronic control unit (HV ECU)  
High-voltage service plug

# CASE STUDY

An owner of a 2005 Prius has brought his vehicle into the shop. He claims that the master warning light comes on every once in a while but goes out after a couple of starts. The technician retrieves the DTCs from the HV ECU and finds a “Shift before ready” code. Upon investigation of the information code, the technician also refers to history data. Here it is determined

that the cause of the fault was that the customer was not waiting for the ready light to stop flashing before placing the transmission into drive. The warning light would go out after three starts if the same condition did not reoccur. The technician took the time to go over the proper startup sequence with the vehicle owner so future problems could be avoided.

## TERMS TO KNOW (continued)

History data

Information codes

Inverter

System main relay (SMR)

## ASE-STYLE REVIEW QUESTIONS

- All of the following statements concerning hybrid high-voltage system safety is true EXCEPT:
  - Disconnect the motor generators prior to turning the ignition off.
  - Disconnect the negative (–) terminal of the auxiliary battery before removing the service plug.
  - Do not attempt to test or service the system for five minutes after the high-voltage service plug is removed.
  - Turn the power switch to the OFF position prior to performing a resistance check.
- Technician A* says HEV batteries can provide over 270 volts.  
*Technician B* says the HEV high-voltage from the MG1 and MG2 to the inverter/converter can be more than 500 volts.  
Who is correct?
  - A only
  - B only
  - Both A and B
  - Neither A nor B
- When working on the high-voltage system, which of the following should be done?
  - Always place the high-voltage service plug where someone will not accidentally reinstall it.
  - Before servicing, use a voltmeter set on 400 VDC to determine if the high-voltage system voltage is at 0 volts.
  - Test the integrity of the insulating gloves prior to use.
  - All of the above.
- Technician A* says the main system relay should be removed before disconnecting the service plug.  
*Technician B* says the high-voltage components are usually identified with a warning label.  
Who is correct?
  - A only
  - B only
  - Both A and B
  - Neither A nor B
- To test the integrity of the insulating gloves:
  - Fill the gloves with water to see if there is a leak.
  - Fill the gloves with air and submerge in water to see if air bubbles arise from any leaks.
  - Shine a flashlight into the glove and see if light escapes.
  - None of the above.
- The high-voltage service plug:
  - Disconnects the inverter/converter from the motor generators.
  - Disconnects the auxiliary battery from the HV battery.
  - Disconnects the HV battery from the system.
  - Provides a connection for the battery charger.
- Technician A* says once the service plug is disconnected, there is no high voltage in the vehicle systems.  
*Technician B* says prior to disconnecting the high-voltage service plug, the vehicle must be turned off and the negative terminal of the auxiliary battery must be disconnected.  
Who is correct?
  - A only
  - B only
  - Both A and B
  - Neither A nor B
- Technician A* says the high-voltage electronic control unit (HV ECU) can shut down the high-voltage system if a fault is detected.  
*Technician B* says if the auxiliary battery voltage goes low, the HV ECU will direct regenerative braking energy to the auxiliary battery.  
Who is correct?
  - A only
  - B only
  - Both A and B
  - Neither A nor B

9. *Technician A* says the HV battery is charged with a conventional flooded battery charger set at 3.5 amps.  
*Technician B* says the HV battery can only be charged if it is removed from the vehicle.  
Who is correct?  
A. A only            C. Both A and B  
B. B only            D. Neither A nor B
10. *Technician A* says that information codes provide more specific indications of the fault location.  
*Technician B* says the freeze frame data is a recording of the driving condition when the malfunction occurred.  
Who is correct?  
A. A only            C. Both A and B  
B. B only            D. Neither A nor B

## ASE CHALLENGE QUESTIONS

1. *Technician A* says if an intermittent fault code is being set in the high-voltage system, water may be entering a connector.  
*Technician B* says to locate the cause of current leakage through the high-voltage cable insulation, spray the cable with water.  
Who is correct?  
A. A only            C. Both A and B  
B. B only            D. Neither A nor B
2. *Technician A* says if the vehicle fails to start, the system main relay may have a fault.  
*Technician B* says if the vehicle fails to start, the HV battery may be too low.  
Who is correct?  
A. A only            C. Both A and B  
B. B only            D. Neither A nor B
3. *Technician A* says a faulty reed switch in the service plug may cause the vehicle to not start.  
*Technician B* says if a fault is set that the HV battery is too hot, the water cooler pump may have failed.  
Who is correct?  
A. A only            C. Both A and B  
B. B only            D. Neither A nor B
4. *Technician A* says the engine is started by the auxiliary battery if the HV SOC is below 15 percent.  
*Technician B* says if the engine fails to start, the inverter may have malfunctioned.  
Who is correct?  
A. A only            C. Both A and B  
B. B only            D. Neither A nor B
5. *Technician A* says if the vehicle operates slowly from a stop, the engine may require a tune-up.  
*Technician B* says the HEV system does not provide a method of performing a compression test on the engine.  
Who is correct?  
A. A only            C. Both A and B  
B. B only            D. Neither A nor B

Name \_\_\_\_\_ Date \_\_\_\_\_

## HYBRID SAFETY

Upon completion of this job sheet, you should be familiar with the critical safety procedures involved in servicing a high-voltage hybrid system.

### ASE Correlation

This job sheet is related to the ASE Electrical/Electronic System Certification Exam's content area: *General Electrical System Diagnosis*; task: Identify location of hybrid vehicle high-voltage circuit disconnect and safety procedures.

This job sheet also is related to the ASE Electrical/Electronic System Certification Exam's content area: *Battery Diagnosis and Service*; task: Identify high-voltage circuits of electric or hybrid electric vehicle and related safety precautions.

### Tools and Materials

HEV

Service manual

Insulating gloves

Eye protection

### Describe the vehicle being worked on:

Year \_\_\_\_\_ Make \_\_\_\_\_ Model \_\_\_\_\_

VIN \_\_\_\_\_ Engine type and size \_\_\_\_\_

### Procedure

Task Completed \_\_\_\_\_

1. Use the service manual information and determine the location on the vehicle for the high-voltage service plug.

\_\_\_\_\_

\_\_\_\_\_

2. What must be done prior to disconnecting the service plug?

\_\_\_\_\_

\_\_\_\_\_

3. How long must you wait after the plug is disconnected before servicing the system?

\_\_\_\_\_

\_\_\_\_\_

4. Access the 12-V auxiliary battery and remove the negative terminal.

5. Test the insulating gloves for leaks. Are the gloves safe to use?  Yes  No  
If no, inform your instructor.

6. Put on the insulating gloves and eye protection.

---

Task Completed

7. Remove the service plug. What device(s) are integrated into the service plug assembly?

---

---

8. Reinstall the service plug.

9. Review your observations with your instructor.

Instructor's Response

---

---

---



Name \_\_\_\_\_ Date \_\_\_\_\_

## HYBRID SYSTEM DTCs

Upon completion of this job sheet, you should be able to diagnose hybrid faults by retrieving DTCs, information codes, and data values.

### ASE Correlation

This job sheet is related to the ASE Electrical/Electronic System Certification Exam's content area: *Accessories Diagnosis and Repairs*; task: Diagnose body electronic systems using a scan tool and determine necessary action.

### Tools and Materials

HEV

Scan tool

Service manual

### Describe the vehicle being worked on:

Year \_\_\_\_\_ Make \_\_\_\_\_ Model \_\_\_\_\_

VIN \_\_\_\_\_ Engine type and size \_\_\_\_\_

### Procedure

Task Completed

1. With the vehicle started, observe if any warning lamps are illuminated. If so, which ones?

\_\_\_\_\_

\_\_\_\_\_

2. Connect the scan tool and check for DTCs in the PCM and the HV ECU. Record any DTCs displayed.

\_\_\_\_\_

\_\_\_\_\_

3. Access and record any information codes that are displayed.

\_\_\_\_\_

\_\_\_\_\_

4. Use the service manual to determine what system component is affected. Record your results.

\_\_\_\_\_

\_\_\_\_\_

5. Access the "HV ECU Data List" screen and record any values that are out of range.

\_\_\_\_\_

\_\_\_\_\_

6. Based on your results, what would be the next logical approach to take?

---

---

Instructor's Response

---

---

<b>DIAGNOSTIC CHART 16-1</b>	
PROBLEM AREA:	HV system
SYMPTOMS:	Engine will not start. Warning lamp illumination.
POSSIBLE CAUSES:	1. Auxiliary battery low. 2. HV battery low SOC. 3. Faulty motor generator. 4. Faulty HV ECU. 5. Poor electrical connections in HV cable. 6. Service plug not installed.

<b>DIAGNOSTIC CHART 16-2</b>	
PROBLEM AREA:	HV battery
SYMPTOMS:	Low SOC. Warning lamp illumination.
POSSIBLE CAUSES:	1. Poor electrical connections. 2. Faulty motor generator or circuits. 3. Faulty HV ECU or circuits. 4. Faulty battery ECU or circuits. 5. Faulty amperage sensor or circuits. 6. Faulty HV battery.

- The current draw of a window motor is being measured.  
*Technician A* says the ammeter can be connected on the power supply side of the motor.  
*Technician B* says the ammeter can be connected on the ground side of the motor.  
Who is correct?  
A. A only                      C. Both A and B  
B. B only                      D. Neither A nor B
- The digital readout of an auto-ranging DVOM that is in the “volts” position displays “13.7.” Which of the following statements is true about this measurement?  
A. The actual value is 13.7 V.  
B. The actual value is 13.7 mV.  
C. The actual value is 137 mV.  
D. More information is needed in order to determine the actual value.
- A voltmeter that is connected across the input and output terminals of an instrument cluster illumination lamp rheostat indicates 12.6 volts with the switch in the maximum brightness position and the engine off. Which of the following statements is true?  
A. The voltage available at the lamps will be about 12.6 volts.  
B. The voltage available at the lamps will be 0.0 volts.  
C. The rheostat is operating correctly.  
D. More information is needed in order to determine whether the lamps will operate correctly.
- An analog voltmeter is indicating 0.45 volt. Which of the following represents this measurement?  
A. 0.450 mV.  
B. 450 mV.  
C. 4.5 mV.  
D. 0.045 V.
- The following information about a fuel injector control signal has been gathered using a lab scope: Frequency is 10 Hz and pulse width is 5 mS.  
*Technician A* says this means that the injector is being turned on and off 10 times per second and that the length of time the injector is open during each “on” pulse is 5 mS.  
*Technician B* says this means that the injector is being turned on and off 10 times per second and that the length of time the injector is closed during each “off” cycle is 95 mS.  
Who is correct?  
A. A only                      C. Both A and B  
B. B only                      D. Neither A nor B
- Oscilloscope testing is being discussed.  
*Technician A* says the preferred method to use when observing the output of a potentiometer is to select an external trigger.  
*Technician B* says, when analyzing the output of a low-voltage computer input sensor, a high trigger level should be selected.  
Who is correct?  
A. A only                      C. Both A and B  
B. B only                      D. Neither A nor B
- The left-rear and right-rear taillights and the left-rear brake light of a vehicle turn on dimly whenever the brake pedal is depressed; however, the right-rear brake light operates at the correct brightness.  
*Technician A* says the left-rear taillight and brake light may have a poor ground connection.  
*Technician B* says the brakelight switch may have excessive resistance.  
Who is correct?  
A. A only                      C. Both A and B  
B. B only                      D. Neither A nor B

8. The horn of a vehicle equipped with a horn relay sounds weak and distorted whenever it is applied. Which of the following is the least likely cause of this problem?
- High resistance in the relay load circuit.
  - High resistance in the horn ground circuit.
  - Excessive voltage drop between the relay load contact and the horn.
  - Excessive voltage drop across the relay coil winding.
9. The circuit breaker that protects an electric window circuit blows whenever an attempt is made to lower the window.  
*Technician A* says the internal resistance of the motor is too high.  
*Technician B* says the window regulator may be sticking.  
Who is correct?
- A only
  - B only
  - Both A and B
  - Neither A nor B
10. The relay coil resistance of an inoperative electric antenna circuit is 0.5 K ohms.  
*Technician A* says this could prevent the proper operation of the antenna motor.  
*Technician B* says this could result in the antenna rising but not retracting.  
Who is correct?
- A only
  - B only
  - Both A and B
  - Neither A nor B
- NOTE:** Question 11 refers to the horn circuit on page 000.
11. The horn circuit wiring diagram is being discussed.  
*Technician A* says the wire that provides the ground path for the high-note horn is an 18-gauge black wire that is part of circuit Z1.  
*Technician B* says the wire that provides power to the horn relay coil is a violet wire that is connected to terminal 87 of the relay.  
Who is correct?
- A only
  - B only
  - Both A and B
  - Neither A nor B
- NOTE:** Question 12 refers to the rear wiper/washer on page 000.
12. The wiring diagram is being discussed.  
*Technician A* says the wire that activates the rear wiper motor module originates at terminal G of the rear window/wiper switch.  
*Technician B* says there are only three wires connected to the accessory switch panel of this vehicle.  
Who is correct?
- A only
  - B only
  - Both A and B
  - Neither A nor B
13. Domestic and import wire sizes are being discussed.  
*Technician A* says a 14-gauge wire is larger than a 16-gauge wire.  
*Technician B* says a 0.8 wire is smaller than a 1.0 wire.  
Who is correct?
- A only
  - B only
  - Both A and B
  - Neither A nor B
14. What is the expected total current flow through a 12-volt circuit with two 12-ohm resistors connected in parallel?
- 0.5 ampere
  - 1 ampere
  - 2 amperes
  - 32 amperes
15. A hydrometer that is being used to measure the specific gravity of a battery indicates 1.240.  
*Technician A* says if the ambient temperature is 70°F, the corrected specific gravity reading will be 1.236.  
*Technician B* says if the battery temperature is 60°F, the corrected specific gravity reading will be 1.232.  
Who is correct?
- A only
  - B only
  - Both A and B
  - Neither A nor B
16. The specific gravity of each of the cells of a battery is as follows: 1.220, 1.245, 1.190, 1.205, 1.210, and 1.215. Which of the following procedures should be performed?
- Charge the battery and then retest the specific gravity.
  - Perform a battery capacity test.
  - Perform a three-minute charge test.
  - Replace the battery.

17. A battery has an open circuit voltage of 12.1 volts.  
*Technician A* says a battery capacity test should now be performed.  
*Technician B* says the battery should now be charged.  
Who is correct?  
A. A only                      C. Both A and B  
B. B only                      D. Neither A nor B
18. Battery test series is being discussed.  
*Technician A* says to perform the battery capacity test first.  
*Technician B* says the state of charge test is always the last test performed.  
Who is correct?  
A. A only                      C. Both A and B  
B. B only                      D. Neither A nor B
19. All of the following could cause a slow cranking condition except:  
A. Overadvanced ignition timing.  
B. Shorted neutral safety switch.  
C. Misaligned starter mounting.  
D. Low battery state of charge.
20. A vehicle owner states that occasionally he is unable to start his car: the engine will start cranking at normal speed and then all of a sudden he will hear a “whee” sound and at that point the engine will stop cranking. After four or five attempts, the engine will finally start.  
*Technician A* says the starter drive gear may be slipping.  
*Technician B* says there may be excessive voltage drop across the starter-solenoid contacts.  
Who is correct?  
A. A only                      C. Both A and B  
B. B only                      D. Neither A nor B
21. A vehicle with a no-crank condition is being tested. When the starter-solenoid “battery” and “start” terminals are connected with a jumper wire, the starter begins to crank the engine.  
*Technician A* says the starter-solenoid may be faulty.  
*Technician B* says the ignition switch may be faulty.  
Who is correct?  
A. A only                      C. Both A and B  
B. B only                      D. Neither A nor B
22. A vehicle is being tested for a slow-crank condition. One lead of a voltmeter is connected to the positive battery post and the other lead is connected to the motor terminal of the starter-solenoid. With the ignition key “on,” the voltmeter indicates 12 volts; when the engine is cranked, the voltmeter indicates 0.2 volt.  
*Technician A* says the positive side of the starter-solenoid load circuit is OK.  
*Technician B* says the negative side of the starter circuit may have excessive voltage drop.  
Who is correct?  
A. A only                      C. Both A and B  
B. B only                      D. Neither A nor B
23. A technician is performing an output test on an AC generator (alternator) rated at 100 amperes with an internal regulator. During the test, it produces 30 amperes. The cause of the low output may be:  
A. Shorted diode.  
B. Open sense circuit to the regulator.  
C. Worn brushes.  
D. Faulty capacitors.
24. A charging system voltage output test reveals the following information:  
1. Base voltage: 12.6 volts.  
2. At 1,500 rpm: 13.3 volts.  
3. At 2,000 rpm with loads on: 13.0 volts.  
*Technician A* says the alternator output voltage is lower than normal.  
*Technician B* says there may be excessive resistance on the insulated side of the charging circuit.  
Who is correct?  
A. A only                      C. Both A and B  
B. B only                      D. Neither A nor B
25. Charging system voltage and amperage on a vehicle equipped with an external voltage regulator is 12.1 volts and 0 amps at 1,500 rpm with all loads applied. When the alternator is full-fielded under the same conditions, the values rise to 13.8 volts and 95 amps. All of the following statements concerning these tests are correct except:  
A. The alternator may have an open field circuit.  
B. The voltage regulator’s voltage limiter contacts may have excessive resistance.  
C. The voltage limiter may have an open coil winding.  
D. The alternator is capable of charging correctly.

26. Alternator diode testing is being discussed.  
*Technician A* says an AC voltmeter can be used to check for faulty diodes.  
*Technician B* says an ammeter can be used to check for faulty diodes.  
Who is correct?  
A. A only                      C. Both A and B  
B. B only                      D. Neither A nor B
27. *Technician A* says that a short to ground in the PCI bus network circuit will result in total bus network failure.  
*Technician B* says an open PCI bus circuit wire to the BCM will result in total bus network failure.  
Who is correct?  
A. A only                      C. Both A and B  
B. B only                      D. Neither A nor B
28. *Technician A* says that the normal at rest voltage for the PCI bus is 0 volt.  
*Technician B* says that the normal active voltage on the PCI bus is 12 volts.  
Who is correct?  
A. A only                      C. Both A and B  
B. B only                      D. Neither A nor B
29. *Technician A* says that the location of an open CAN B bus circuit can be located by shorting the other circuit to ground while observing the module communications on the scan tool.  
*Technician B* says if the fault code indicated that a CAN C circuit is shorted, this would cause a total failure of the CAN C bus.  
Who is correct?  
A. A only                      C. Both A and B  
B. B only                      D. Neither A nor B
30. *Technician A* says the normal voltmeter reading on the CAN B(+) circuit with the ignition key in the RUN position is between 280 and 920mv.  
*Technician B* says normal CAN C bus termination is 60 ohms.  
Who is correct?  
A. A only                      C. Both A and B  
B. B only                      D. Neither A nor B
31. How much total resistance is in a 12-volt circuit that is drawing 4 amperes?  
A. 0.333 ohm  
B. 3 ohms  
C. 4.8 ohms  
D. 48 ohms
32. A replacement halogen bulb for a composite lamp was replaced but it lasted for a very short period of time; all of the other bulbs on the car are working fine. Which of the following could account for the premature failure of the bulb?  
A. Excessive charging system voltage.  
B. Fingerprints on the bulb.  
C. Excessive voltage drop in the power feed circuit to the bulb.  
D. Excessive resistance in the ground circuit of the bulb.
33. The turn signals of a vehicle are inoperative. The green indicator bulbs that are supposed to flash when the turn signal switch is moved to either the left- or right-turn position do not turn on at all.  
*Technician A* says the turn signal flasher contacts could have fused closed.  
*Technician B* says the circuit from the turn signal flasher to the turn signal switch may be open.  
Who is correct?  
A. A only                      C. Both A and B  
B. B only                      D. Neither A nor B
- NOTE:** Question 34 refers to the headlight switch on page 000.
34. Referring to the wiring diagram: the lighting circuit of this vehicle has the wire that is connected to the headlamp dimmer switch shorted to ground. Which of the following statements concerning this problem is true?  
A. The 10-amp fuse will blow when the headlights are turned on.  
B. The 15-amp fuse will blow immediately.  
C. The 10-amp fuse will blow immediately.  
D. The circuit breaker will open the circuit when the headlights are turned on.
- NOTE:** Question 35 refers to the multifunction switch on page 000.



35. Which of the following statements about the circuit is true?
- A. The retract relay-up coil power feed comes from terminal 106 of the multifunction switch.
  - B. The power feed to the multifunction switch comes from the theft warning main control amp.
  - C. The retract relay-up load circuit power feed comes from terminal 111 of the multifunction switch.
  - D. Terminal 106 of the multifunction switch is connected to ground.
36. *Technician A* says a voltmeter connected to the input wire of an IVR should indicate a fluctuating voltage.  
*Technician B* says an open IVR on a single-gauge system could prevent the proper operation of the coolant temperature warning light.  
Who is correct?
- A. A only
  - B. B only
  - C. Both A and B
  - D. Neither A nor B
37. The fuel gauge of a vehicle equipped with an electromagnetic gauge cluster indicates a full tank, regardless of the actual amount of fuel in the tank. Which of the following could be the cause of this problem?
- A. Open IVR.
  - B. Open fuel gauge sender unit.
  - C. An open circuit between the gauge and the sending unit.
  - D. A grounded circuit between the fuel gauge and the fuel gauge sender unit.
38. Referring to the wiring diagram: the charge indicator light of this vehicle does not come on when the ignition switch is in the ON position and the engine is turned off. Which of the following statements concerning this problem is true?
- A. The 10-ohm resistor inside the voltage regulator may be open.
  - B. The field relay contacts may be stuck closed.
  - C. The rotor winding may be shorted.
  - D. The 50-ohm resistor may be open.
39. The low-speed position of the windshield wiper system is inoperative; the high-speed position is working fine.  
*Technician A* says circuit 58 may be open.  
*Technician B* says circuit 63 may be open.  
Who is correct?
- A. A only
  - B. B only
  - C. Both A and B
  - D. Neither A nor B
40. The medium-hi speed of the blower motor circuit is inoperative; the rest of the blower speeds are fine.  
*Technician A* says circuit 752 may be open.  
*Technician B* says the middle resistor in the blower motor resistor assembly may be open.  
Who is correct?
- A. A only
  - B. B only
  - C. Both A and B
  - D. Neither A nor B

**NOTE:** Question 38 refers to the charging system wiring diagram on page 000.

**NOTE:** Question 41 refers to the power window circuit on page 000.

41. The power window motor in the wiring diagram is completely inoperative. With the master window switch placed in the DOWN position, the following voltages are measured at each terminal:

Terminal #	Voltage
1	12 V
2	0 V
3	12 V
4	0 V
5	12 V
6	12 V
7	0 V
8	12 V
9	0 V
10	12 V
11	0 V

Which of the following statements represents the cause of this problem?

- A. The master switch is faulty.
- B. The window switch is faulty.
- C. The motor is faulty.
- D. There is a poor ground in the circuit.

**NOTE:** Question 42 refers to the body computer on page 000.

42. The “liftgate ajar” lamp is remaining on even after the liftgate is closed. Voltage at BCM terminal J2-4 is 0.0 volts.

*Technician A* says that the BCM may be faulty.

*Technician B* says that the liftgate switch may need to be replaced.

Who is correct?

- A. A only
- B. B only
- C. Both A and B
- D. Neither A nor B

43. A Chrysler multiplex system is being discussed. *Technician A* says a voltmeter connected to the “Bus +” of any multiplexed component should indicate 12 volts with the ignition switch in the ON position.

*Technician B* says a 12-volt test light can be used to test for power at various multiplexed components.

Who is correct?

- A. A only
- B. B only
- C. Both A and B
- D. Neither A nor B

44. Sweep testing a potentiometer with a voltmeter and an ohmmeter is being discussed.

Referring to a voltmeter, *Technician A* says that the positive lead should be connected to the “feedback” terminal and that the negative lead should be connected to the “ground” terminal.

Referring to an ohmmeter, *Technician B* says that the positive lead should be connected to the “feedback” terminal and that the negative lead should be connected to the “reference” terminal.

Who is correct?

- A. A only
- B. B only
- C. Both A and B
- D. Neither A nor B

**NOTE:** Question 45 refers to the diagnostic chart on page 000.

45. The diagnostic chart is being used to troubleshoot a GM vehicle that has a current diagnostic trouble code 24 stored in memory. The ECC display panel is indicating the correct vehicle speed. Which of the following represents the probable cause of the trouble code?

- A. Open circuit 437.
- B. Faulty speedometer gear.
- C. Faulty vehicle speed sensor.
- D. Possible ECM problem.

**NOTE:** Question 46 refers to the Ford illuminated entry system on page 000.

46. The illuminated entry system is inoperative; neither the right nor the left outer door handle will activate the system. The courtesy lights and each lock cylinder LED will operate when the courtesy lamp switch is turned on. Which of the following represents the possible cause of this problem?
- A. Open in circuit 54.
  - B. Short to ground in circuit 465.
  - C. Open in circuit 57.
  - D. Short to ground in circuit 54.

**NOTE:** Question 47 refers to the instrument cluster schematic on page 000.

47. The electronic instrument cluster is totally inoperative; none of the display segments will illuminate.

*Technician A* says there may be an open in circuit 389.

*Technician B* says circuit 151 may be open.

Who is correct?

- A. A only
  - B. B only
  - C. Both A and B
  - D. Neither A nor B
48. The ambient temperature sensor of a vehicle equipped with an automatic A/C system is being tested. The resistance of the sensor is about 1 K ohms.

*Technician A* says the sensor is out of range and needs to be replaced.

*Technician B* says the temperature of the sensor needs to be known before it can be accurately tested.

Who is correct?

- A. A only
- B. B only
- C. Both A and B
- D. Neither A nor B

49. Air bag module replacement is being discussed.

*Technician A* says the negative battery cable should be disconnected at the beginning of the repair.

*Technician B* says the reserve energy should be allowed to dissipate after the SIR fuse is removed.

Who is correct?

- A. A only
- B. B only
- C. Both A and B
- D. Neither A nor B

**NOTE:** Question 50 refers to the GM electronic sunroof circuit on page 000.

50. The electric sunroof of the vehicle will close but not open. All of the following could be the cause of this problem except:

- A. Open wire between the “open” relay and the motor.
- B. Faulty “open” relay load circuit contacts.
- C. Faulty control switch.
- D. Open wire between the control switch and the “open” relay.

<b>to convert these</b>	<b>to these</b>	<b>multiply by</b>
<b>TEMPERATURE</b>		
Centigrade Degrees	Fahrenheit Degrees	1.8 then +32
Fahrenheit Degrees	Centigrade Degrees	0.556 after -32

<b>to convert these</b>	<b>to these</b>	<b>multiply by</b>
<b>LENGTH</b>		
Millimeters	Inches	0.03937
Inches	Millimeters	25.4
Meters	Feet	3.28084
Feet	Meters	0.3048
Kilometers	Miles	0.62137
Miles	Kilometers	1.60935

<b>to convert these</b>	<b>to these</b>	<b>multiply by</b>
<b>AREA</b>		
Square Centimeters	Square Inches	0.155
Square Inches	Square Centimeters	6.45159

<b>to convert these</b>	<b>to these</b>	<b>multiply by</b>
<b>VOLUME</b>		
Cubic Centimeters	Cubic Inches	0.06103
Cubic Inches	Cubic Centimeters	16.38703
Cubic Centimeters	Liters	0.001
Liters	Cubic Centimeters	1000
Liters	Cubic Inches	61.025
Cubic Inches	Liters	0.01639
Liters	Quarts	1.05672

<b>to convert these</b>	<b>to these</b>	<b>multiply by</b>
Quarts	Liters	0.94633
Liters	Pints	2.11344
Pints	Liters	0.47317
Liters	Ounces	33.81497
Ounces	Liters	0.02957

<b>to convert these</b>	<b>to these</b>	<b>multiply by</b>
<b>WEIGHT</b>		
Grams	Ounces	0.03527
Ounces	Grams	28.34953
Kilograms	Pounds	2.20462
Pounds	Kilograms	0.45359

<b>to convert these</b>	<b>to these</b>	<b>multiply by</b>
<b>WORK</b>		
Centimeter Kilograms	Inch Pounds	0.8676
Inch Pounds	Centimeter Kilograms	1.15262
Meter Kilograms	Foot Pounds	7.23301
Foot Pounds	Newton Meters	1.3558

<b>to convert these</b>	<b>to these</b>	<b>multiply by</b>
<b>PRESSURE</b>		
Kilograms/sq. cm	Pounds/sq. inch	14.22334
Pounds/sq. inch	Kilograms/sq. cm	0.07031
Bar	Pounds/sq. inch	14.504
Pounds/sq. inch	Bar	0.06895

**Association of Automotive Aftermarket Distributors****Allen Test Equipment**

Kalamazoo, MI

**Alltest, Inc., Div. of Triplet Corp.**

Palatine, IL

**Baum Tools Unlimited, Inc.**

Longboat Key, FL

**Big A Auto Parts, APS Inc.**

Houston, TX

**Carquest Corp.**

Tarrytown, NY

**Fluke Corp.**

Everett, WA

**KD Tools, Danaher Tool Group**

Lancaster, PA

**Kent-Moore, Div. of SPX Corp.**

Warren, MI

**Mac Tools**

Washington Courthouse, OH

**Matco Tools**

Stow, OH

**NAPA Hand/Service Tools**

Lancaster, PA

**OTC, Div. of SPX Corp.**

Owatonna, MN

**Parts Plus**

Memphis, TN

**Snap-On Tools Corp.**

Kenosha, WI

**Sun Test Equipment, Div. of Snap-On Tools**

Kenosha, WI

**NOTE:** Certain Ford component names have been changed in this Service Manual to conform to Society of Automotive Engineers (SAE) directive J1930.

SAE J1930 standardizes automotive component names for all vehicle manufacturers.

<b>New Term</b>	<b>New Acronyms/Abbreviations</b>	<b>Old Acronyms/Term</b>
Accelerator pedal	AP	– Accelerator
Air cleaner	ACL	– Air cleaner
Air conditioning	A/C	– A/C – Air conditioning
Barometric pressure	BARO	– BP – Barometric pressure
Battery positive voltage	B+	– BATT+ – Battery positive
Camshaft position	CMP	– Camshaft sensor
Carburetor	CARB	– CARB – Carburetor
Charge air cooler	CAC	– After cooler – Intercooler
Closed loop	CL	– EEC
Closed throttle position	CTP	– CTP – Closed throttle position
Clutch pedal position	CPP	– CES – CIS – Clutch engage switch – Clutch interlock switch
Continuous fuel injection	CFI	– Continuous fuel injection
Continuous trap oxidizer	CTOX	– CTO
Crankshaft position	CKP	– CPS – VRS – Variable reluctance sensor
Data link connector	DLC	– Self-Test connector
Diagnostic test mode	DTM	– Self-Test mode
Diagnostic trouble code	DTC	– Self Test code



<b>New Term</b>	<b>New Acronyms/Abbreviations</b>	<b>Old Acronyms/Term</b>
Distributor ignition	DI	<ul style="list-style-type: none"> <li>– CBD</li> <li>– DS</li> <li>– TFI</li> <li>– Closed bowl distributor</li> <li>– Duraspark ignition</li> <li>– Thick film ignition</li> </ul>
Early fuel evaporation	EFE	<ul style="list-style-type: none"> <li>– EFE</li> <li>– Early fuel evaporation</li> </ul>
Electrically erasable programmable read only memory	EEPROM	<ul style="list-style-type: none"> <li>– E2PROM</li> </ul>
Electronic ignition	EI	<ul style="list-style-type: none"> <li>– DIS</li> <li>– EDIS</li> <li>– Distributorless ignition system</li> <li>– Electronic distributorless ignition system</li> </ul>
Engine control module	ECM	<ul style="list-style-type: none"> <li>– ECM</li> <li>– Engine control module</li> </ul>
Engine coolant level	ECL	<ul style="list-style-type: none"> <li>– Engine coolant level</li> </ul>
Engine coolant temperature	ECT	<ul style="list-style-type: none"> <li>– ECT</li> <li>– Engine coolant temperature</li> </ul>
Engine speed	RPM	<ul style="list-style-type: none"> <li>– RPM</li> <li>– Revolutions per minute</li> </ul>
Erasable programmable read only memory	EPROM	<ul style="list-style-type: none"> <li>– EPROM</li> <li>– Erasable programmable read only memory</li> </ul>
Evaporative emission	EVAP	<ul style="list-style-type: none"> <li>– EVP sensor</li> <li>– EVR solenoid</li> </ul>
Exhaust gas recirculation	EGR	<ul style="list-style-type: none"> <li>– EGR</li> <li>– Exhaust gas recirculation</li> </ul>
Fan control	FC	<ul style="list-style-type: none"> <li>– EDF</li> <li>– Electro-Drive fan</li> </ul>
Flash electrically erasable programmable read only memory	FEEPROM	<ul style="list-style-type: none"> <li>– FEEPROM</li> <li>– Flash electrically erasable programmable read only memory</li> </ul>

<b>New Term</b>	<b>New Acronyms/Abbreviations</b>	<b>Old Acronyms/Term</b>
Flash erasable programmable read only memory	FEPROM	– FEPROM – Flash erasable programmable read only memory
Flexible fuel	FF	– FCS – FFS – FFV – Fuel compensation sensor – Flex fuel sensor
Fourth gear	4GR	– Fourth gear
Fuel pump	FP	– FP – Fuel pump
Generator	GEN	– ALT – Alternator
Ground	GND	– GND – Ground
Heated oxygen sensor	HO <sub>2</sub> S	– HEGO – Heated exhaust gas oxygen sensor
Idle air control	IAC	– IAC – Idle air bypass control
Idle speed control	ISC	– Idle speed control
Ignition control module	ICM	– DIS module – EDIS module – TFI module
Indirect fuel injection	IFI	– IDFI – Indirect fuel injection
Inertia fuel shutoff	IFS	– Inertia switch
Intake air temperature	IAT	– ACT – Air charge temperature
Knock sensor	KS	– KS – Knock sensor
Malfunction indicator lamp	MIL	– CEL – “CHECK ENGINE” light – “SERVICE ENGINE SOON” light
Manifold absolute pressure	MAP	– MAP – Manifold absolute pressure

New Term	New Acronyms/Abbreviations	Old Acronyms/Term
Manifold differential pressure	MDP	– MDP – Manifold differential pressure
Manifold surface temperature	MST	– MST – Manifold surface temperature
Manifold vacuum zone	MVZ	– MVZ – manifold vacuum zone
Mass air flow	MAF	– MAF – Mass air flow
Mixture control	MC	– Mixture control
Multiport fuel injection	MFI	– EFI – Electronic fuel injection
Nonvolatile random access memory	NVRAM	– NVM – Non-volatile memory
On-board diagnostic	OBD	– Self-test – On-board diagnostic
Open loop	OL	– OL – Open loop
Oxidation catalytic converter	OC	– COC – Conventional oxidation catalyst
Oxygen sensor	O <sub>2</sub> S	– EGO
PARK/NEUTRAL position	PNP	– NDS – NGS – TSN – Neutral drive switch – Neutral gear switch – Transmission select neutral
Periodic trap oxidizer	PTOX	– PTOX – Periodic trap oxidizer
Power steering pressure	PSP	– PSPS – Power steering pressure switch
Powertrain control module	PCM	– ECA – ECM – ECU – EEC processor – Engine control assembly – Engine control module – Engine control unit

<b>New Term</b>	<b>New Acronyms/Abbreviations</b>	<b>Old Acronyms/Term</b>
Programmable read only memory	PROM	<ul style="list-style-type: none"> <li>– PROM</li> <li>– Programmable read only memory</li> </ul>
Pulsed secondary air injection	PAIR	<ul style="list-style-type: none"> <li>– MPA</li> <li>– PA</li> <li>– Thermactor II</li> <li>– Managed pulse air</li> <li>– Pulse air</li> </ul>
Random access memory	RAM	<ul style="list-style-type: none"> <li>– RAM</li> <li>– Random access memory</li> </ul>
Read only memory	ROM	<ul style="list-style-type: none"> <li>– ROM</li> <li>– Read only memory</li> </ul>
Relay module	RM	<ul style="list-style-type: none"> <li>– RM</li> <li>– Relay module RM</li> </ul>
Scan tool	ST	<ul style="list-style-type: none"> <li>– GST</li> <li>– NGS</li> <li>– Generic scan tool</li> <li>– New generation STAR tester</li> <li>– Enhanced scan tool OBD II ST</li> </ul>
Secondary air injection	AIR	<ul style="list-style-type: none"> <li>– AM</li> <li>– CT</li> <li>– MTA</li> <li>– Air management</li> <li>– Conventional thermactor</li> <li>– Managed thermactor air</li> <li>– Thermactor</li> </ul>
Sequential multiport fuel injection	SFI	<ul style="list-style-type: none"> <li>– SEFI</li> <li>– Sequential electronic fuel injection</li> </ul>
Service reminder indicator	SRI	<ul style="list-style-type: none"> <li>– SRI</li> <li>– Service reminder indicator</li> </ul>
Smoke puff limiter	SPL	<ul style="list-style-type: none"> <li>– SPL</li> <li>– Smoke puff limiter</li> </ul>
Supercharger	SC	<ul style="list-style-type: none"> <li>– SC</li> <li>– Supercharger</li> </ul>
Supercharger bypass	SCB	<ul style="list-style-type: none"> <li>– SCB</li> <li>– Supercharger bypass</li> </ul>

<b>New Term</b>	<b>New Acronyms/Abbreviations</b>	<b>Old Acronyms/Term</b>
System readiness test	SRT	--
Thermal vacuum valve	TVV	- Thermal vacuum switch
Third gear	3GR	- Third gear
Three-way catalytic converter	TWC	- TWC - Three-way catalytic converter
Three-way + oxidation catalytic converter	TWC+OC	- TWC & COC - Dual bed - Three-way catalyst and conventional oxidation catalyst
Throttle body	TB	- TB - Throttle body
Throttle body fuel injection	TBI	- CFI - Central fuel injection - EFI
Throttle position	TP	- TP - Throttle position
Torque converter clutch	TCC	- CCC - CCO - MCCC - Converter clutch control - Converter clutch override - Modulated converter clutch control
Transmission control module	TCM	- 4EAT module
Transmission range	TR	- PRNDL
Turbocharger	TC	- TC - Turbocharger
Vehicle speed sensor	VSS	- VSS - Vehicle speed sensor
Voltage regulator	VR	- VR - Voltage regulator
Volume air flow	VAF	- VAF - Volume air flow
Warm-up oxidation catalytic converter	WU-OC	- WV-OC - Warm-up oxidation catalytic converter

---

<b>New Term</b>	<b>New Acronyms/Abbreviations</b>	<b>Old Acronyms/Term</b>
Warm-up three-way converter catalytic	WU-TWC	– WU-TWC – Warm-up three-way catalytic converter
Wide-open throttle	WOT	– Full throttle – WOT – Wide-open throttle



# GLOSSARY

## GLOSARIO

Note: **Terms are highlighted in bold**, followed by **Spanish translation in color**.

- A circuit** A generator circuit that uses an external grounded field circuit. The regulator is on the ground side of the field coil.
- Circuito A** Circuito regulador del generador que utiliza un circuito inductor externo puesto a tierra. En el circuito A, el regulador se encuentra en el lado a tierra de la bobina inductora.
- Actuators** Devices that perform the actual work commanded by the computer. They can be in the form of a motor, relay, switch, or solenoid.
- Accionadores** Dispositivos que realizan el trabajo efectivo que ordena la computadora. Dichos dispositivos pueden ser un motor, un relé, un conmutador o un solenoide.
- Air bag module** Composed of the air bag and inflator assembly that is packaged into a single module.
- Unidad del Airbag** Formada por el conjunto del Airbag y el inflador. Este conjunto se empaqueta en una sola unidad.
- Air bag system** A supplemental restraint that will deploy a bag out of the steering wheel or passenger-side dash panel to provide additional protection against head and face injuries during an accident.
- Sistema de Airbag** Resguardo complementario que expulsa una bolsa del volante o del panel de instrumentos del lado del pasajero para proveer protección adicional contra lesiones a la cabeza y a la cara en caso de un accidente.
- Air gap** The space between the trigger wheel teeth and the sensor.
- Entrehierro** El espacio entre los dientes de la rueda disparadora y el sensor.
- Ambient temperature** The temperature of the outside air.
- Temperatura ambiente** Temperatura del aire ambiente.
- Ambient temperature sensor** Thermistor used to measure the temperature of the air entering the vehicle.
- Sensor de temperatura ambiente** Termistor utilizado para medir la temperatura del aire que entra al vehículo.
- Ammeter** A test meter used to measure current draw.
- Amperímetro** Instrumento de prueba utilizado para medir la intensidad de una corriente.
- Amperes** See current.
- Amperios** Véase corriente.
- Analog** A voltage signal that is infinitely variable or can be changed within a given range.
- Señal analógica** Señal continua y variable que debe traducirse a valores numéricos discontinuos para poder ser tratada por una computadora.
- Analog signal** Varying voltage with infinite values within a defined range.
- Señal análoga** Voltaje variable con infinidad de valores dentro de un límite definido de velocidad.
- Antilock brakes (ABS)** A brake system that automatically pulsates the brakes to prevent wheel lock-up under panic stop and poor traction conditions.
- Frenos antibloqueo** Sistema de frenos que pulsa los frenos automáticamente para impedir el bloqueo de las ruedas en casos de emergencia y de tracción pobre.
- Antitheft device** A device or system that prevents illegal entry or driving of a vehicle. Most are designed to deter entry.
- Dispositivo a prueba de hurto** Un dispositivo o sistema que previene la entrada o conducción ilícita de un vehículo. La mayoría se diseñan para detener la entrada.
- A-pillar** The pillar in front of the driver or passenger that supports the windshield.
- Soporte A** Soporte enfrente del conductor o del pasajero que sostiene el parabrisas.
- Arming sensor** A device that places an alarm system into "ready" to detect an illegal entry.
- Sensor de armado** Un dispositivo que pone "listo" un sistema de alarma para detectar una entrada ilícita.
- Aspirator** Tubular device that uses a venturi effect to draw air from the passenger compartment over the in-car sensor. Some manufacturers use a suction motor to draw the air over the sensor.
- Aspirador** Dispositivo tubular que utiliza un efecto venturi para extraer aire del compartimiento del pasajero sobre el sensor dentro del vehículo. Algunos fabricantes utilizan un motor de succión para extraer el aire sobre el sensor.
- Audio system** The sound system for a vehicle; can include radio cassette player, CD player, amplifier, and speakers.
- Sistema de audio** El sistema de sonido de un vehículo; puede incluir el radio, el tocadiscos, el toca discos compactos, el amplificador, y las bocinas.
- Automatic door locks** A system that automatically locks all doors through the activation of one switch.
- Cerraduras automáticas de puerta** Un sistema que cierra todas las puertas automáticamente al activar un solo conmutador.
- Automatic seat belt system** Automatically puts the shoulder and/or lap belt around the driver or occupant. The automatic seat belt is operated by DC motors that move the belts by means of carriers on tracks.
- Sistema automático de correas de asiento** Funciona automáticamente, poniendo el cinturón de seguridad sobre el hombro y el pecho del chofer y el pasajero del automóvil. La correa automática del asiento trabaja por medio de motores DC, o sea corriente directa, que da movimiento a las correas transportadoras.
- Automatic traction control** A system that prevents slippage of one of the drive wheels. This is done by applying the brake at that wheel and/or decreasing the engine's power output.
- Control automático de tracción** Un sistema que previene el patinaje de una de las ruedas de mando. Esto se efectúa aplicando el freno en esa rueda y/o disminuyendo la salida de potencia del motor.
- Average responding** A method used to read AC voltage.
- Respuesta media** Un método que se emplea para leer la tensión de corriente alterna.
- Back probe** A term used to mean that a test is being performed on the circuit while the connector is still connected to the component. The test probes are inserted into the back of the wire connector.

**Sonda exploradora de retorno** Término utilizado para expresar que se está llevando a cabo una prueba del circuito mientras el conector sigue conectado al componente. Las sondas de prueba se insertan a la parte posterior del conector de corriente.

**BAT** Terminal of a generator, starter, or solenoid that has direct battery feed connected to it.

**Forma de aproximación del balancín** Terminal de un generador, encendedor o solenoide conectado directamente a la batería.

**Battery ECU** Used to monitor the condition of the HV battery assembly in an HEV. The battery ECU determines the SOC of the HV battery by monitoring voltage, current, and temperature.

**UCE de la batería** Se utiliza para monitorear del ensamblado de la batería del VH en un VHE. La UCE de la batería determina el EDC de la batería del VH al monitorear el voltaje, la corriente y la temperatura.

**Battery holddowns** Brackets that secure the battery to the chassis of the vehicle.

**Portabatería** Los sostenes que fijan la batería al chasis del vehículo.

**Battery leakage test** Used to determine if current is discharging across the top of the battery case.

**Prueba de pérdida de corriente de la batería** Prueba utilizada para determinar si se está descargando corriente a través de la parte superior de la caja de la batería.

**Battery terminal test** Checks for poor electrical connections between the battery cables and terminals. Use a voltmeter to measure voltage drop across the cables and terminals.

**Prueba del borne de la batería** Verifica si existen conexiones eléctricas pobres entre los cables y los bornes de la batería. Utiliza un voltímetro para medir caídas de tensión entre los cables y los bornes.

**B circuit** A generator regulator circuit that is internally grounded. In the B circuit, the voltage regulator controls the power side of the field circuit.

**Circuito B** Circuito regulador del generador puesto internamente a tierra. En el circuito B, el regulador de tensión controla el lado de potencia del circuito inductor.

**B-codes** DTCs that are assigned to the vehicle's body systems and control modules.

**Códigos B** Instrucciones de transmisión digital (DTC) que se asignan a los sistemas de la carrocería del vehículo y a los módulos de control.

**Bench test** A term used to indicate that the unit is to be removed from the vehicle and tested.

**Prueba de banco** Término utilizado para indicar que la unidad será removida del vehículo para ser examinada.

**Bendix drive** A type of starter drive that uses the inertia of the spinning starter motor armature to engage the drive gear to the gears of the flywheel. This type starter drive was used on early models of vehicles and is rarely seen today.

**Acoplamiento Bendix** Un tipo del acoplamiento del motor de arranque que usa la inercia de la armadura del motor de arranque giratorio para endentar el engranaje de mando con los engranajes del volante. Este tipo de acoplamiento del motor de arranque se usaba en los modelos vehículos antiguos y se ven raramente.

**Bezel** The retaining trim around a component.

**Bisel** El resto del decorado alrededor de un componente.

**Bimetallic gauges** Simple dial and needle indicators that transform the heating effect of electricity into mechanical movement.

**Calibradores bimetálicos** Un cuadrante simple y agujas indicadoras que transforman el efecto del calor de la electricidad en un movimiento mecánico.

**Binary numbers** Strings of zeroes and ones, or on's and off's, which represent a numeric value.

**Números binarios** Franjas que indican ceros (0) y unos (1), de prendido/ apagado, representando el valor numérico.

**B-pillar** The pillar located over the shoulder of the driver or passenger.

**Soporte B** Soporte ubicado sobre el hombro del conductor o del pasajero.

**Breakout box** Allows the technician to test circuits, sensors, and actuators by providing test points.

**Caja de interruptores** Le permite al técnico probar los circuitos, los monitores y actuadores al indicar los puntos de prueba.

**Brushes** Electrically conductive sliding contacts, usually made of copper and carbon.

**Escobillas** Contactos deslizantes de conducción eléctrica, por lo general hechos de cobre y de carbono.

**Bucking coil** One of the coils in a three-coil gauge. It produces a magnetic field that bucks or opposes the low reading coil.

**Bobina compensadora** Una de las bobinas de un calibre de tres bobinas. Produce un campo magnético que es contrario o en oposición a la bobina de baja lectura.

**Buffer** A buffer cleans up a voltage signal. These are used with PM generator sensors to change the AC voltage to a digitalized signal.

**Separador** Un separador aguza una señal del tensión. Estos se usan con los sensores generadores PM para cambiar la tensión de corriente alterna a una señal digitalizado.

**Bulkhead connector** A large connector that is used when many wires pass through the bulkhead or firewall.

**Conector del tabique** Un conector que se usa al pasar muchos alambres por el tabique o mamparo de encendios.

**Bus bar** A common electrical connection to which all of the fuses in the fuse box are attached. The bus bar is connected to battery voltage.

**Barra colectora** Conexión eléctrica común a la que se conectan todos los fusibles de la caja de fusibles. La barra colectora se conecta a la tensión de la batería.

**Capacitance discharge sensor** A form of piezo sensor that uses the discharge from a variable capacitor.

**Sensor de descarga de capacitancia** Un tipo de sensor que utiliza la descarga de un capacitor variable.

**Capacity test** The part of the battery test series that checks the battery's ability to perform when loaded.

**Prueba de capacidad** Parte de la serie de prueba de la batería que verifica la capacidad de funcionamiento de la batería cuando está cargada.

**Captured signal** A signal stored in a DSO's memory.

**Señal de captura** La señal restauradora se mantiene en la memoria indicada con las letras DSO.

**Carbon monoxide** An odorless, colorless, and toxic gas that is produced as a result of combustion.

**Monóxido de carbono** Gas inodoro, incoloro y tóxico producido como resultado de la combustión.

**Carbon tracking** A condition where paths of carbon will allow current to flow to points that are not intended. This condition is most commonly found inside distributor caps.

**Rastreo de carbón** Una condición en la cual las trayectorias del carbón permiten fluir el corriente a los puntos no indicados. Esta condición se encuentra comunmente dentro de las tapas del distribuidor.

**Cartridge fuses** See maxi-fuse.

**Fusibles cartucho** Véase maxifusible.

**Cathode ray tube** Similar to a television picture tube. It contains a cathode that emits electrons and an anode that attracts them. The screen of the tube will glow at the points that are hit by the electrons.

**Tubo de rayos catódicos** Parecidos a un tubo de pantalla de televisor. Contiene un cátodo que emite los electrones y un ánodo que los atrae. La pantalla del tubo iluminará en los puntos en donde pegan los electrones.

**Caustic** Chemicals that have the ability to destroy or eat through something and that are extremely corrosive.

**Cáusticos** Químicos que tienen la habilidad de destruir o carcomer algo, y que son extremadamente corrosivos.

**Cell element** The assembly of a positive and negative plate in a battery.

**Elemento de pila** La asamblea de una placa positiva y negativa en una batería.

**Charge** To pass an electric current through the battery in an opposite direction than during discharge.

**Cargar** Pasar una corriente eléctrica por la batería en una dirección opuesta a la usada durante la descarga.

**Charge rate** The speed at which the battery can safely be recharged at a set amperage.

**Indicador de carga eléctrica** La velocidad a la cual la batería puede ser recargada seguramente a un amperaje establecido.

**Charging system requirement test** Diagnostic test used to determine the total electrical demand of the vehicle's electrical system.

**Prueba del requisito del sistema de carga** Prueba diagnóstica utilizada para determinar la exigencia eléctrica total del sistema eléctrico del vehículo.

**CHMSL** The abbreviation for center high-mounted stop light, often referred to as the third brake light.

**CHMSL** La abreviación para el faro de parada montada alto en el centro que suele referirse como el faro de freno tercero.

**Circuit** The path of electron flow consisting of the voltage source, conductors, load component, and return path to the voltage source.

**Circuito** Trayectoria del flujo de electrones, compuesto de la fuente de tensión, los conductores, el componente de carga y la trayectoria de regreso a la fuente de tensión.

**Clamping diode** A diode that is connected in parallel with a coil to prevent voltage spikes from the coil from reaching other components in the circuit.

**Diodo de bloqueo** Un diodo que se conecta en paralelo con una bobina para prevenir que los impulsos de tensión lleguen a otros componentes en el circuito.

**Clock spring** Maintains a continuous electrical contact between the wiring harness and the air bag module.

**Muelle de reloj** Mantiene un contacto eléctrico continuo entre el cableado preformado y la unidad del Airbag.

**Closed circuit** A circuit that has no breaks in the path and allows current to flow.

**Circuito cerrado** Circuito de trayectoria ininterrumpida que permite un flujo continuo de corriente.

**Cold cranking amps (CCA)** Rating indicates the battery's ability to deliver a specified amount of current to start an engine at low ambient temperatures.

**Amperaje de arranque en frío (CCA, por su sigla en inglés)**

Régimen que indica la capacidad de la batería para proporcionar una cantidad de corriente específica, capaz de hacer arrancar un motor a temperatura ambiente baja.

**Cold soak** A key off condition that allows the engine coolant temperature to equal with ambient temperature.

**Amperios de arranque en frío** Tasa indicativa de la capacidad de la batería para producir una cantidad específica de corriente para arrancar un motor a bajas temperaturas ambiente.

**Color codes** Used to assist in tracing the wires. In most color codes, the first group of letters designates the base color of the insulation and the second group of letters indicates the color of the tracer.

**Códigos de colores** Utilizados para facilitar la identificación de los alambres. Típicamente, el primer alfabeto representa el color base del aislamiento y el segundo representa el color del indicador.

**Common connector** A connector that is shared by more than one circuit and/or component.

**Conector común** Un conector que se comparte entre más de un circuito y/o componente.

**Commutator** A series of conducting segments located around one end of the armature.

**Conmutador** Serie de segmentos conductores ubicados alrededor de un extremo de la armadura.

**Component locator** Service manual used to find where a component is installed in the vehicle. The component locator uses both drawings and text to lead the technician to the desired component.

**Manual para indicar los elementos componentes** Manual de servicio utilizado para localizar dónde se ha instalado un componente en el vehículo. En dicho manual figuran dibujos y texto para guiar al mecánico al componente deseado.

**Composite bulb** A headlight assembly that has a replaceable bulb in its housing.

**Bombilla compuesta** Una asamblea de faros cuyo cárter tiene una bombilla reemplazable.

**Compound motor** A motor that has the characteristics of a series-wound and a shunt-wound motor.

**Motor compuesta** Un motor que tiene las características de un motor exitado en serie y uno en derivación.

**Computer** An electronic device that stores and processes data and is capable of operating other devices.

**Computadora** Dispositivo electrónico que almacena y procesa datos y que es capaz de ordenar a otros dispositivos.

**Conductance** A measurement of the battery's plate surface that is available for chemical reaction, determining how much power the battery can supply.

**Conductancia** Medida de la superficie de la placa de la batería que está lista para la reacción química, determinando así cuánta potencia puede suplir la batería.

**Conductor** A material in which electrons flow or move easily.

**Conductor** Una material en la cual los electrones circulen o se mueven fácilmente.

**Continuity** Refers to the circuit being continuous with no opens.

**Continuidad** Se refiere al circuito ininterrumpido, sin aberturas.

**Control assembly** Provides for driver input into the automatic temperature control microprocessor. The control assembly is also referred to as the control panel.

**Montaje de control** Un microprocesador automático que le da al Chofer la información necesaria sobre el control de temperatura. El montaje de control es llamado también panel de control.

**Converter** A DC/DC transformer that converts the voltage from 270 volts DC to 14 volts DC to recharge the auxiliary battery and to power 12-volt electrical components on an HEV.

- Convertidor** Transformador CD-CD que convierte el voltaje de 270 voltios a 14 voltios de CD para recargar la batería auxiliar y para darles potencia a los componentes eléctricos de 12 voltios en un VHE.
- Corona effect** A condition where high voltage leaks through a wire's insulation and produces a light or illumination; worn insulation on spark plug wires causes this.
- Efecto corona** Una condición en la cual la alta tensión se escapa por la insulación del alambre y produce una luz o una iluminación; esto se causa por la insulación desgastada en los alambres de las bujías.
- Cowl** The top portion of the front of the automobile body that supports the windshield and dashboard.
- Capucha** Esta es la parte principal de la carrocería en el frente del automóvil y es la que sostiene el parabrisas y el tablero de instrumentos.
- Crash sensor** Normally open electrical switch designed to close when subjected to a predetermined amount of jolting or impact.
- Sensor de impacto** Un conmutador normalmente abierto diseñado a cerrarse al someterse a un sacudo de una fuerza determinada o un impacto.
- Crimping** The process of bending, or deforming by pinching, a connector so that the wire connection is securely held in place.
- Engarzado** Proceso a través del cual se curva o deforma un conector mediante un pellizco para que la conexión de alambre se mantenga firme en su lugar.
- Crimping tool** Has different areas to perform several functions. This single tool will cut the wire, strip the insulation, and crimp the connector.
- Herramienta prensadora** Tiene diferentes áreas para poder ofrecer varias funciones. Esta simple herramienta cortará el cable, aislará y prensará el conector.
- Crocus cloth** Used to polish metals. While polishing, it removes very little metal.
- Paño de color azafrán** Se usa para pulir los metales. Su acción es suave y al pulir remueve pequeñas partículas de metal.
- Cross-fire** The undesired firing of a spark plug that results from the firing of another spark plug. This is caused by electromagnetic induction.
- Encendido transversal** El encendido no deseado de una bujía que resulta del encendido de otra bujía. Esto se causa por la inducción electromagnética.
- CRT** The common acronym for a cathode ray tube.
- CRT** La sigla común de un tubo de rayos catódicos.
- Curb height** The height of the vehicle when it has no passengers or loads, and normal fluid levels and tire pressure.
- Altura del contén** La altura del vehículo cuando no lleva pasajeros ni cargas, y los niveles de los fluidos y de la presión de las llantas son normales.
- Current** The aggregate flow of electrons through a wire. One ampere represents the movement of 6.25 billion billion electrons (or one coulomb) past one point in a conductor in one second.
- Corriente** Flujo combinado de electrones a través de un alambre. Un amperio representa el movimiento de 6,25 mil millones de mil millones de electrones (o un coulombio) que sobrepasa un punto en un conductor en un segundo.
- Current draw test** Diagnostic test used to measure the amount of current that the starter draws when actuated. It determines the electrical and mechanical condition of the starting system.
- Prueba de la intensidad de una corriente** Prueba diagnóstica utilizada para medir la cantidad de corriente que el arrancador tira cuando es accionado. Determina las condiciones eléctricas y mecánicas del sistema de arranque.
- Current output testing** Diagnostic test used to determine the maximum output of the AC generator.
- Prueba de la salida de una corriente** Prueba diagnóstica utilizada para determinar la salida máxima del generador de corriente alterna.
- Cycle** One set of changes in a signal that repeats itself several times.
- Ciclo** Una serie de cambios en una señal que se repite varias veces.
- Darlington** A special type of configuration usually consisting of two transistors fabricated on the same chip or mounted in the same package.
- Darlington** Tipo especial de configuración que generalmente consiste en 2 transistores fabricados en el mismo chip o montados en el mismo paquete.
- d'Arsonval gauge** A gauge design that uses the interaction of a permanent magnet and an electromagnet, and the total field effect to cause needle movement.
- Calibrador d'Arsonval** Calibrador diseñado para utilizar la interacción de un imán permanente y de un electroimán, y el efecto inductor total para generar el movimiento de la aguja.
- D'Arsonval movement** A small coil of wire mounted in the center of a permanent horseshoe-type magnet. A pointer or needle is mounted to the coil.
- Movimiento D'Arsonval** Se refiere a una pequeña bobina de cable montada en el centro de un permanente imán diseñado como la herradura de caballo. El puntero o la aguja está montada sobre la bobina.
- Deep cycling** Discharging the battery completely before recharging it.
- Operación cíclica completa** La descarga completa de la batería previo al recargo.
- Demonstration mode** SmartBeam™ function that allows operation of the automatic high beams and high-beam indicator while the vehicle is stationary and under any ambient lighting conditions.
- Mando de demostración** Función del rayo inteligente de marca registrada que permite la operación de rayos altos automáticos y del indicador de rayo alto cuando el vehículo está parado y bajo cualesquiera condiciones de iluminación ambientales.
- DERM** Designed to provide an energy reserve of 36 volts to assure deployment for a few seconds when vehicle voltage is low or lost. The DERM also maintains constant diagnostic monitoring of the electrical system. It will store a code if a fault is found and provide driver notification by illuminating the warning light.
- DERM** El significado de este término se refiere al diseño que mantiene una reserva de energía de 36 voltios la que asegura, por unos pocos segundos, la salida de la corriente cuando el voltaje del vehículo es bajo o se ha perdido. El DERM mantiene también un constante diagnóstico monitor del sistema eléctrico. Guarda también una clave en caso de que se encuentre alguna falla y le da al chofer una alerta iluminando las señales.
- Diagnostic module** Part of an electronic control system that provides self-diagnostics and/or a testing interface.
- Módulo de diagnóstico** Parte de un sistema controlado electrónicamente que provee autodiagnóstico y/o una interfase de pruebas.
- Diagnostic trouble codes (DTCs)** Fault codes that represent a circuit failure in a monitored system.
- Códigos de destello** Códigos de fallas de diagnóstico (CFD o DTC) que se muestran por medio de los destellos de una lámpara o diodo luminoso.
- Diaphragm** A thin, flexible, circular plate that is held around its outer edge by the horn housing, allowing the middle to flex.



**Diafragma** Es una fina placa circular flexible que es sostenida alrededor de su borde externo por el cuerno del embrague, permitiendo que el centro se doble.

**Digital** A voltage signal is either on-off, yes-no, or high-low.

**Digital** Una señal de tensión está Encendida-Apagada, es Sí-No o Alta-Baja.

**Digital multimeter (DMM)** Displays values using liquid crystal displays instead of a swinging needle. They are basically computers that determine the measured value and display it for the technician.

**Multímetro digital** Exhibe valores usando cristal líquido para desplegar, en cambio de una aguja giratoria. Son básicamente computadores que determinan el valor medido y lo muestran al técnico.

**Digital signal** A voltage value that has two states. The states can be on/off or high/low.

**Señal digital** El valor del voltaje que tiene dos ventajas. Una señal muestra prendido/apagado y la otra alta/baja.

**Dimmer switch** A switch in the headlight circuit that provides the means for the driver to select either high-beam or low-beam operation, and to switch between the two. The dimmer switch is connected in series within the headlight circuit and controls the current path for high and low beams.

**Conmutador reductor** Conmutador en el circuito para faros delanteros que le permite al conductor elegir la luz larga o la luz corta, y conmutar entre las dos. El conmutador reductor se conecta en serie dentro del circuito para faros delanteros y controla la trayectoria de la corriente para la luz larga y la luz corta.

**Diode** An electrical one-way check valve that will allow current to flow in one direction only.

**Diodo** Válvula eléctrica de retención, de una vía, que permite que la corriente fluya en una sola dirección.

**Diode rectifier bridge** A series of diodes that are used to provide a reasonably constant DC voltage to the vehicle's electrical system and battery.

**Puente rectificador de diodo** Serie de diodos utilizados para proveerles una tensión de corriente continua bastante constante al sistema eléctrico y a la batería del vehículo.

**Diode/stator test** Performed to determine the condition of the diodes. This is done to eliminate the possibility of damage being done to new components.

**Prueba del estator diodo** Funciona para determinar la condición de los diodos. Esto se hace para eliminar la posibilidad de daños que puedan suceder en los nuevos componentes.

**Diode trio** Used by some manufacturers to rectify the stator of an AC generator current so that it can be used to create the magnetic field in the field coil of the rotor.

**Trio de diodos** Utilizado por algunos fabricantes para rectificar el estator de la corriente de un generador de corriente alterna y poder así utilizarlo para crear el campo magnético en la bobina inductora del rotor.

**Direct drive** A situation where the drive power is the same as the power exerted by the device that is driven.

**Transmisión directa** Una situación en la cual el poder de mando es lo mismo que la potencia empleada por el dispositivo arrastrado.

**Discriminating sensors** Part of the air bag circuitry; these sensors are calibrated to close with speed changes that are great enough to warrant air bag deployment. These sensors are also referred to as crash sensors.

**Sensores discriminadores** Una parte del conjunto de circuitos de Airbag; estos sensores se calibran para cerrar con los cambios de la velocidad que son bastante severas para justificar el despliegue del Airbag. Estos sensores también se llaman los sensores de impacto.

**Drive coil** A hollowed field coil used in a positive engagement starter to attract the movable pole shoe of the starter.

**Bobina de excitación** Una bobina inductora hueca empleada en un encendedor de acoplamiento directo para atraer la pieza polar móvil del encendedor.

**DSO** A common acronym for a digital storage oscilloscope.

**DSO** Una sigla común del osciloscopio de almacenamiento digital.

**Dual ramping** A sensor circuit that provides a more precise method of determining the temperature. This circuit starts with a highvoltage value when cold and will decrease as temperatures increase. When the voltage reaches a predetermined value, the PCM will switch to lower resistance circuit causing the sense reading to go high again and provides a second set of inputs.

**Voltaje de diente de sierra doble** Un circuito de sensor que brinda un método más preciso de determinar la temperatura. Este circuito comienza con un valor de voltaje alto cuando está frío y desciende a medida que la temperatura se incrementa. Cuando el voltaje alcanza un valor predeterminado, el PCM pasa a un circuito de resistencia más baja, lo que hace que la lectura del sensor vuelva a subir y proporciona un segundo conjunto de información entrante.

**Dump valve** A safety switch that releases vacuum to the servo when the brake pedal is pressed.

**Válvula de descargue** Un interruptor de seguridad que facilita el vacío al servo cuando se presiona el pedal del freno.

**Duty cycle** The percentage of on time to total cycle time.

**Ciclo de trabajo** Porcentaje del trabajo efectivo a tiempo total del ciclo.

**Eddy currents** Small induced currents.

**Corriente de Foucault** Pequeñas corrientes inducidas.

**Electrical load** The working device of the circuit.

**Carga eléctrica** Dispositivo de trabajo del circuito.

**Electrochemical** The chemical action of two dissimilar materials in a chemical solution.

**Electroquímico** Acción química de dos materiales distintos en una solución química.

**Electrolysis** The producing of chemical changes by passing electrical current through an electrolyte.

**Electrólisis** La producción de los cambios químicos al pasar un corriente eléctrico por un electrolito.

**Electrolyte** A solution of 64 percent water and 36 percent sulfuric acid.

**Electrolito** Solucion de un 64 percent de agua y un 36 percent de ácido sulfúrico.

**Electromagnetic gauge** Gauge that produces needle movement by magnetic forces.

**Calibrador electromagnético** Calibrador que genera el movimiento de la aguja mediante fuerzas magnéticas.

**Electromagnetic induction** The production of voltage and current within a conductor as a result of relative motion within a magnetic field.

**Inducción electromagnética** Producción de tensión y de corriente dentro de un conductor como resultado del movimiento relativo dentro de un campo magnético.

**Electromagnetic interference (EMI)** An undesirable creation of electromagnetism whenever current is switched on and off.

**Interferencia electromagnética** Fenómeno de electromagnetismo no deseable que resulta cuando se conecta y se desconecta la corriente.

**Electromagnetism** A form of magnetism that occurs when current flows through a conductor.

**Electromagnetismo** Forma de magnetismo que ocurre cuando la corriente fluye a través de un conductor.

**Electromechanical** A device that uses electricity and magnetism to cause a mechanical action.

**Electromecánico** Un dispositivo que causa una acción mecánica por medio de la electricidad y el magnetismo.

**Electromotive force (EMF)** See voltage.

**Fuerza electromotriz** Véase tensión.

**Electronic level controller (ELC)** The computer that controls the automatic suspension system.

**Controler de nivel electrónico** Este es el computador que controla el sistema automático de suspensión.

**Electrostatic discharge (ESD) straps** Ground your body to prevent static discharges that may damage electronic components.

**Correas electrostáticas de descargue** Estas aíslan su cuerpo para prevenir descargas estáticas que puedan dañar los componentes electrónicos.

**EMI** Electro-magnetic interference.

**EMI** La interferencia electromagnética.

**Environmental data** A saved snap shot of the conditions when the fault occurred.

**Datos ambientales** Una instantánea guardada de las condiciones en que se produjo el fallo.

**Equivalent series load (equivalent resistance)** The total resistance of a parallel circuit. It is equivalent to the resistance of a single load in series with the voltage source.

**Carga en serie equivalente (resistencia equivalente)** Resistencia total de un circuito en paralelo, equivalente a la resistencia de una sola carga en serie con la fuente de tensión.

**Excitation current** Current that magnetically excites the field circuit of the AC generator.

**Corriente de excitación** Corriente que excita magnéticamente al circuito inductor del generador de corriente alterna.

**Face shields** Clear plastic shields that protect the entire face.

**Careta de soldador** Caretas de plástico claro que protegen toda la cara.

**Failsoft** Computer substitution of a fixed input value if a sensor circuit should fail. This provides for system operation, but at a limited function. Also referred to as the "Limp-In" mode.

**Falla activa** Sustitución por la computadora de un valor fijo de entrada en caso de que ocurra una falla en el circuito de un sensor. Esto asegura el funcionamiento del sistema, pero a una capacidad limitada.

**False wipes** Unnecessary wipes that occur when the control knob of the multifunction switch is in one of the five automatic wiper sensitivity positions and no rain or moisture is apparent within the wipe pattern on the windshield glass.

**Limpieza de parabrisas falsa** Limpieza de parabrisas innecesaria que se produce cuando la perilla de control del interruptor multifunción se encuentra en una de las cinco posiciones de sensibilidad del limpiaparabrisas, y no hay lluvia ni humedad aparente dentro del patrón ni del cristal del parabrisas.

**Fast charging** Battery charging using a high amperage for a short period of time.

**Carga rápida** Carga de la batería que utiliza un amperaje máximo por un corto espacio de tiempo.

**Feedback** 1. Data concerning the effects of the computer's commands are fed back to the computer as an input signal. Used to determine if the desired result has been achieved. 2. A condition that can occur when

electricity seeks a path of lower resistance, but the alternate path operates another component than that intended. Feedback can be classified as a short.

**Realimentación** 1. Datos referentes a los efectos de las órdenes de la computadora se suministran a la misma como señal de entrada. La realimentación se utiliza para determinar si se ha logrado el resultado deseado. 2. Condición que puede ocurrir cuando la electricidad busca una trayectoria de menos resistencia, pero la trayectoria alterna opera otro componente que aquel deseado. La realimentación puede clasificarse como un cortocircuito.

**Fiber optics** A medium of transmitting for the transmission of light through polymethylmethacrylate plastic that keeps the light rays parallel even if there are extreme bends in the plastic.

**Transmisión por fibra óptica** Técnica de transmisión de luz por medio de un plástico de polimetacrilato de metilo que mantiene los rayos de luz paralelos aunque el plástico esté sumamente torcido.

**Field current draw test** Diagnostic test that determines if there is current available to the field windings.

**Prueba de la intensidad de una corriente inductora** Prueba diagnóstica que determina si se está generando corriente a los devanados inductores.

**Field relay** The relay that controls the amount of current going to the field windings of a generator. This is the main output control unit for a charging system.

**Relé inductor** El relé que controla la cantidad del corriente a los devanados inductores de un generador. Es la unedad principal de potencia de salida de un sistema de carga.

**Fire extinguisher** A portable apparatus that contains chemicals, water, foam, or special gas that can be discharged to extinguish a small fire.

**Extintor de incendios** Aparato portátil que contiene elementos químicos, agua, espuma o gas especial que pueden descargarse para extinguir un incendio pequeño.

**Flammable** A substance that supports combustion.

**Inflamable** Sustancia que promueve la combustión.

**Flash** To remove the existing programming and overwrite it with new software.

**Limpiar** Así se remueve el programa existente y lo reemplaza con programas nuevos.

**Flash codes** Diagnostic trouble codes (DTCs) that are displayed by flashing a lamp or LED.

**Códigos intermitentes** Códigos de fallas de diagnóstico (CFD) que se muestran en una lámpara intermitente o LED.

**Flat rate** A pay system in which a technicians are paid for the amount of work he does. Each job has a flat rate time. Pay is based on that time, regardless of how long it takes to complete the job.

**Tarifa bloque** Sistema de pago en el que se le paga al técnico por cada hora de trabajo realizado. Cada trabajo tiene un tiempo de tarifa bloque. El pago se basa en ese tiempo sin importar cuánto tiempo se lleve para terminarlo.

**Floor jack** A portable hydraulic tool used to raise and lower a vehicle.

**Gato de pie** Herramienta hidráulica portátil utilizada para levantar y bajar un vehículo.

**Forward-bias** A positive voltage that is applied to the P-type material and negative voltage to the N-type material of a semiconductor.

**Polarización directa** Tensión positiva aplicada al material P y tensión negativa aplicada al material N de un semiconductor.

**Free speed test** Diagnostic test that determines the free rotational speed of the armature. This test is also referred to as the no-load test.



**Prueba de velocidad libre** Prueba diagnóstica que determina la velocidad giratoria libre de la armadura. A dicha prueba se le llama prueba sin carga.

**Freeze Frame** An OBD II requirement that specified engine conditions be recorded when an emissions related fault is first detected.

**Cuadro congelado** Un requisito OBD II que especifica que las condiciones del motor deben registrarse en cuanto se detecta una falla relacionada con las emisiones.

**Freeze frame data** A recording of the driving condition when the malfunction occurred. This is useful for determining how the vehicle was operating at the time and for locating any input or output values that are out of range.

**Datos de trama fija** Archivo de las condiciones de manejo cuando sucede una falla. Es conveniente para determinar cómo operaba el vehículo en ese momento y para localizar cualesquier valores de entrada y salida que estén fuera de banda.

**Frequency** The number of complete oscillations that occur during a specific time, measured in hertz.

**Frecuencia** El número de oscilaciones completas que ocurren durante un tiempo específico, medidas en Hertz.

**Full field** Field windings that are constantly energized with full battery current. Full fielding will produce maximum AC generator output.

**Campo completo** Devanados inductores que se excitan constantemente con corriente total de la batería. EL campo completo producirá la salida máxima de un generador de corriente alterna.

**Full field test** Diagnostic test used to isolate if the detected problem lies in the AC generator or the regulator.

**Prueba de campo completo** Prueba diagnóstica utilizada para determinar si el problema descubierto se encuentra en el generador de corriente alterna o en el regulador.

**Functional test** Checks the operation of the system as the technician observes the different results.

**Prueba funcional** Verifica la operación del sistema mientras el técnico observa los diferentes resultados.

**Fuse** A replaceable circuit protection device that will melt should the current passing through it exceed its rating.

**Fusible** Dispositivo reemplazable de protección del circuito que se fundirá si la corriente que fluye por el mismo excede su valor determinado.

**Fuse box** A term used that indicates the central location of the fuses contained in a single holding fixture.

**Caja de fusibles** Término utilizado para indicar la ubicación central de los fusibles contenidos en un solo elemento permanente.

**Fusible link** A wire made of meltable material with a special heat-resistant insulation. When there is an overload in the circuit, the link melts and opens the circuit.

**Cartucho de fusible** Alambre hecho de material fusible con aislamiento especial resistente al calor. Cuando ocurre una sobrecarga en el circuito, el cartucho se funde y abre el circuito.

**Gassing** The conversion of a battery's electrolyte into hydrogen and oxygen gas.

**Burbujeo** La conversión del electrolito de una batería al gas de hidrógeno y oxígeno.

**Gauge** 1. A device that displays the measurement of a monitored system by the use of a needle or pointer that moves along a calibrated scale. 2. The number that is assigned to a wire to indicate its size. The larger the number the smaller the diameter of the conductor.

**Calibrador** 1. Dispositivo que muestra la medida de un sistema regulado por medio de una aguja o indicador que se mueve a través de una escala

calibrada. 2. El número asignado a un alambre indica su tamaño. Mientras mayor sea el número, más pequeño será el diámetro del conductor.

**Gauss gauge** A meter that is sensitive to the magnetic field surrounding a wire conducting current. The gauge needle will fluctuate over the portion of the circuit that has current flowing through it. Once the ground has been passed, the needle will stop fluctuating.

**Calibrador gauss** Instrumento sensible al campo magnético que rodea un alambre conductor de corriente. La aguja del calibrador se moverá sobre la parte del circuito a través del cual fluye la corriente. Una vez se pasa a tierra, la aguja dejará de moverse.

**Glitches** Unwanted voltage spikes that are seen on a voltage trace. These are normally caused by intermittent opens or shorts.

**Irregularidades espontáneas** Impulsos de tensión no deseables que se ven en una traza de tensión. Estos se causan normalmente por las aberturas o cortos intermitentes.

**Grids** A series of horizontal, ceramic, silver-compounded lines that are baked into the surface of the window.

**Rejillas** Una serie de líneas horizontales, de cerámica plateada, combinadas y endurecidas (horneadas) en la superficie de la ventana.

**Ground** The common negative connection of the electrical system that is the point of lowest voltage.

**Tierra** Conexión negativa común del sistema eléctrico. Es el punto de tensión más baja.

**Ground circuit test** A diagnostic test performed to measure the voltage drop in the ground side of the circuit.

**Prueba del circuito a tierra** Prueba diagnóstica llevada a cabo para medir la caída de tensión en el lado a tierra del circuito.

**Ground side** The portion of the circuit that is from the load component to the negative side of the source.

**Lado a tierra** Parte del circuito que va del componente de carga al lado negativo de la fuente.

**Grounded circuit** An electrical defect that allows current to return to ground before it has reached the intended load component.

**Circuito puesto a tierra** Falla eléctrica que permite el regreso de la corriente a tierra antes de alcanzar el componente de carga deseado.

**Growler** Test equipment used to test starter armatures for shorts and grounds. It produces a very strong magnetic field that is capable of inducing a current flow and magnetism in a conductor.

**Indicador de cortocircuitos** Equipo de prueba utilizado para localizar cortocircuitos y tierra en armaduras de arranque. Genera un campo magnético sumamente fuerte, capaz de inducir flujo de corriente y magnetismo en un conductor.

**Hall-effect switch** A sensor that operates on the principle that if a current is allowed to flow through thin conducting material being exposed to a magnetic field, another voltage is produced.

**Conmutador de efecto Hall** Sensor que funciona basado en el principio de que si se permite el flujo de corriente a través de un material conductor delgado que ha sido expuesto a un campo magnético, se produce otra tensión.

**Halogen** The term used to identify a group of chemically related nonmetallic elements. These elements include chlorine, fluorine, and iodine.

**Halógeno** Término utilizado para identificar un grupo de elementos no metálicos relacionados químicamente. Dichos elementos incluyen el cloro, el flúor y el yodo.

**Hand tools** Tools that use only the force generated from the body to operate.

**Herramientas manuales** Herramientas que sólo utilizan la fuerza que genera el cuerpo para manejarlas.

**Hard codes** Failures that were detected the last time the BCM tested the circuit.

**Códigos indicadores de dureza** Fallas que fueron detectadas la última vez que el funcionamiento indicado con las letras BCM probó el circuito.

**Hard-shell connector** An electrical connector that has a hard plastic shell that holds the connecting terminals of separate wires.

**Conector de casco duro** Conector eléctrico con casco duro de plástico que sostiene separados los bornes conectores de alambres individuales.

**Hazard Communication Standard** The original bases of the Right-To-Know laws.

**Normalización de Comunicado sobre Riesgos** Las bases originales de las leyes de derecho de información.

**Hazardous materials** Materials that can cause illness, injury, or death or that pollute water, air, or land.

**Materiales peligrosos** Materiales que pueden causar enfermedades, daños, o la muerte, o que contaminan el agua o la tierra.

**Heat-shrink tubing** A hollow insulation material that shrinks to an airtight fit over a connection when exposed to heat.

**Tubería contraída térmicamente** Material aislante hueco que se contrae para acomodarse herméticamente sobre una conexión cuando se encuentra expuesto al calor.

**Hertz** A measurement of frequency.

**Hertzios** Es una unidad de frecuencia.

**High-voltage electronic control unit (HV ECU)** In an HEV, controls the motor generators and the engine based on torque demand.

**Unidad de control electrónico de alto voltaje (UCE AV)** En un VHE controla los generadores del motor y el motor basándose en la demanda del par motor.

**High-voltage service plug** The HEV is equipped with a high-voltage service plug that disconnects the HV battery from the system.

**Bujía de servicio de alto voltaje** El VHE está equipado con una bujía de servicio de alto voltaje que desconecta la batería del VH del sistema.

**History data** Data that is stored when a fault is set in an HEV, which can be used to determine if a customer's concern is actually a problem with the system.

**Historial de datos** Los datos que se archivan cuando ocurre una falla en un VHE y que pueden usarse para determinar si la preocupación del cliente es en realidad un problema con el sistema.

**Hoist** A lift that is used to raise an entire vehicle.

**Elevador** Montacargas utilizado para elevar el vehículo en su totalidad.

**Hold-in winding** A winding that holds the plunger of a solenoid in place after it moves to engage the starter drive.

**Devanado de retención** Un devanado que posiciona el núcleo móvil de un solenoide después de que mueva para accionar el acoplamiento del motor de arranque.

**Hydrometer** A test instrument used to check the specific gravity of the electrolyte to determine the battery's state of charge.

**Hidrómetro** Instrumento de prueba utilizado para verificar la gravedad específica del electrolito y así determinar el estado de carga de la batería.

**Igniter** A combustible device that converts electric energy into thermal energy to ignite the inflator propellant in an air bag system.

**Ignitor** Un dispositivo combustible que convierte la energía eléctrica a la energía térmica para encender el propelente inflador en un sistema Airbag.

**Illuminated entry actuator** Contains a printed circuit and a relay.

**Actuador iluminado de entradas** Contiene un circuito impreso y un relevador.

**Impedance** The combined opposition to current created by the resistance, capacitance, and inductance of a test meter or circuit.

**Impedancia** Oposición combinada a la corriente generada por la resistencia, la capacitancia y la inductancia de un instrumento de prueba o de un circuito.

**Inductive reactance** The result of current flowing through a conductor and the resultant magnetic field around the conductor that opposes the normal flow of current.

**Reactancia inductiva** El resultado de un corriente que circule por un conductor y que resulta en un campo magnético alrededor del conductor que opone el flujo normal del corriente.

**Information codes** HEV codes that provide more information and freeze frame data concerning the DTCs. Information codes along with the DTC indicate more precisely the location of the fault.

**Códigos de información** Códigos del VHE que proporcionan mayor información y datos de trama fija que concierne a los códigos de diagnóstico de fallas (CDF). Los códigos de información junto con los CDF indican con más precisión la localización de la falla.

**Instrument voltage regulator (IVR)** Provides a constant voltage to the gauge regardless of the voltage output of the charging system.

**Instrumento regulador de tensión** Le provee tensión constante al calibrador, sin importar cual sea la salida de tensión del sistema de carga.

**Insulated circuit resistance test** A voltage drop test that is used to locate high resistance in the starter circuit.

**Prueba de la resistencia de un circuito aislado** Prueba de la caída de tensión utilizada para localizar alta resistencia en el circuito de arranque.

**Insulated side** The portion of the circuit from the positive side of the source to the load component.

**Lado aislado** Parte del circuito que va del lado positivo de la fuente al componente de carga.

**Insulator** A material that does not allow electrons to flow easily through it.

**Aislador** Una material que no permite circular fácilmente los electrones.

**Integrated circuit (IC chip)** A complex circuit of thousands of transistors, diodes, resistors, capacitors, and other electronic devices that are formed onto a small silicon chip. As many as 30,000 transistors can be placed on a chip that is 1/4 inch (6.35 mm) square.

**Circuito integrado (Fragmento CI)** Circuito complejo de miles de transistores, diodos, resistores, condensadores, y otros dispositivos electrónicos formados en un fragmento pequeño de silicio. En un fragmento de 1/4 de pulgada (6,35 mm) cuadrada, pueden colocarse hasta 30.000 transistores.

**Intermittent codes** Those that have occurred in the past but were not present during the last BCM test of the circuit.

**Códigos intermitentes** Son los que han ocurrido en el pasado pero no estuvieron presentes durante la última prueba del circuito, efectuada de acuerdo con las especificaciones de las letras BCM.

**Inverter** Controls current flow between the motor generators and the HV battery in an HEV. Converts HV battery DC voltage into three-phase alternating current for the motor generators and also converts high-voltage AC from the motor generators to DC voltage to charge the HV battery.

**Inversor** Controla el flujo de la corriente entre los generadores del motor y la batería del VH en un VHE. Convierte el voltaje de la batería del VH en corriente alterna de tres fases para los generadores del motor, y

también convierte la corriente alterna de alto voltaje de los generadores del motor a voltaje de corriente directa para cargar la batería del VH.

**J1962 breakout box (BOB)** A special tool that provides a pass through test point that connects in series between the DLC and the scan tool. This provides easy testing of voltages and resistance of any of the DLC circuits without risk of damage to the DLC.

**Caja de conexiones J1962** Herramienta especial que proporciona un paso mediante el punto de prueba que se conecta en series entre el circuito del control del enlace de datos (DLC) y el instrumento de exploración. Esto proporciona una prueba fácil de los voltajes y la resistencia en cualquiera de los circuitos del DLC sin riesgo de dañar el DLC.

**Jack stands** Support devices used to hold the vehicle off the floor after it has been raised by the floor jack.

**Soportes de gato** Dispositivos de soporte utilizados para sostener el vehículo sobre el suelo después de haber sido levantado con el gato de pie.

**Jump Assist** A feature of the HEV to provide for the 12 volt auxiliary battery to recharge the HV battery.

**Puente auxiliar** Una característica del HEV para que la batería auxiliar de 12 voltios recargue la batería HV.

**Jumper wire** A wire used in diagnostics that is made up of a length of wire with a fuse or circuit breaker and has alligator clips on both ends.

**Cable conector** Una alambre empleado en los diagnósticos que se comprende de un trozo de alambre con un fusible o un interruptor y que tiene una pinza de conexión en ambos lados.

**Keyless entry** A lock system that allows for locking and unlocking of a vehicle with a touch keypad instead of a key.

**Entrada sin llave** Un sistema de cerradura que permite cerrar y abrir un vehículo por medio de un teclado en vez de utilizar una llave.

**Knock** The spontaneous auto-ignition of the remaining fuel/air mixture in the engine combustion chamber that occurs after normal combustion has started causing the formation of standing ultrasonic waves.

**Autoencendido** El encendido automático espontáneo de la mezcla de combustible/aire restante en la cámara de combustión del motor que se produce después de que comienza la combustión normal, y que causa la formación de ondas ultrasónicas estacionarias.

**Knock sensor** Measures engine knock, or vibration, and converts the vibration into a voltage signal.

**Sensor de autoencendido** Mide el autoencendido del motor, o vibración, y convierte la vibración en una señal de voltaje.

**KOEO** Key ON, Engine OFF.

**KOEO** Llave puesta, motor apagado.

**KOER** Key ON, Engine RUNNING.

**KOER** Llave puesta, motor en marcha.

**kV** Kilovolt or 1000 volts.

**kV** Kilovolito o 1000 voltios.

**Lamination** The process of constructing something with layers of materials that are firmly connected.

**Laminación** El proceso de construir algo de capas de materiales unidas con mucha fuerza.

**Lamp** A device that produces light as a result of current flow through a filament. The filament is enclosed within a glass envelope and is a type of resistance wire that is generally made from tungsten.

**Lámpara** Dispositivo que produce luz como resultado del flujo de corriente a través de un filamento. El filamento es un tipo de alambre de resistencia hecho por lo general de tungsteno, que es encerrado dentro de una bombilla.

**Lamp sequence check** Used to determine problems by observing the operation of the warning lights under different conditions.

**Lámpara verificadora de secuencias** Usada para determinar problemas al observar el funcionamiento de las luces de alerta bajo condiciones diferentes.

**Light-emitting diode (LED)** A gallium-arsenide diode that converts the energy developed when holes and electrons collide during normal diode operation into light.

**Diodo emisor de luz** Diodo semiconductor de galio y arseniuro que convierte en luz la energía producida por la colisión de agujeros y electrones durante el funcionamiento normal del diodo.

**Limit switch** A switch used to open a circuit when a predetermined value is reached. Limit switches are normally responsive to a mechanical movement or temperature changes.

**Disyuntor de seguridad** Un conmutador que se emplea para abrir un circuito al alcanzar un valor predeterminado. Los disyuntores de seguridad suelen ser responsivos a un movimiento mecánico o a los cambios de temperatura.

**Liquid crystal display (LCD)** A display that sandwiches electrodes and polarized fluid between layers of glass. When voltage is applied to the electrodes, the light slots of the fluid are rearranged to allow light to pass through.

**Visualizador de cristal líquido** Visualizador digital que consta de dos láminas de vidrio selladas, entre las cuales se encuentran los electrodos y el fluido polarizado. Cuando se aplica tensión a los electrodos, se rompe la disposición de las moléculas para permitir la formación de caracteres visibles.

**Live module** An ABS module that has not been deployed.

**Módulo activo** El módulo que no ha sido desplegado.

**Logic probe** A test instrument used to detect a pulsing signal.

**Sonda lógica** Un instrumento de prueba que se emplea para detectar una señal pulsante.

**Magnetic induction sensors** Sensors that use the principle of inducing a voltage into a winding by use of a moving magnetic field.

**Sensores de inducción magnética** Sensores que utilizan el principio de inducir un voltaje en un devanado mediante un campo magnético móvil.

**Magnetic pulse generator** Sensor that uses the principle of magnetic induction to produce a voltage signal. Magnetic pulse generators are commonly used to send data concerning the speed of the monitored component to the computer.

**Generador de impulsos magnéticos** Sensor que funciona según el principio de inducción magnética para producir una señal de tensión. Los generadores de impulsos magnéticos se utilizan comúnmente para transmitir datos a la computadora relacionados a la velocidad del componente regulado.

**Magnetism** An energy form resulting from atoms aligning within certain materials, giving the materials the ability to attract other metals.

**Magnetismo** Forma de energía que resulta de la alineación de átomos dentro de ciertos materiales y que le da a éstos la capacidad de atraer otros metales.

**Magneto resistive (MR) sensors** Consist of the magneto resistive sensor element, a permanent magnet, and an integrated signal conditioning circuit to make use of the magneto resistive effect.

**Sensores de movimiento magneto resistivos (MR)** Están compuestos por el elemento sensor de movimiento magneto resistivo, un imán permanente y un circuito de condicionamiento de señales integrado para hacer uso del efecto magneto resistivo.

**Material Safety Data Sheets (MSDS)** Contain information about each hazardous material in the workplace.

**Hojas de datos de seguridad del material (HDSM)** Contienen información sobre cada material peligroso en el lugar de trabajo.



**Maxi-fuse** A circuit protection device that looks similar to blade-type fuses except they are larger and have a higher amperage capacity. Maxi-fuses are used because they are less likely to cause an underhood fire when there is an overload in the circuit. If the fusible link burns in two, it is possible that the "hot" side of the fuse could come into contact with the vehicle frame and the wire could catch on fire.

**Maxifusible** Dispositivo de protección del circuito parecido a un fusible de tipo de cuchilla, pero más grande y con mayor capacidad de amperaje. Se utilizan maxifusibles porque existen menos probabilidades de que ocasionen un incendio debajo de la capota cuando ocurra una sobrecarga en el circuito. Si el cartucho de fusible se quemase en dos partes, es posible que el lado "cargado" del fusible entre en contacto con el armazón del vehículo y que el alambre se encienda.

**Metri-pack connector** Special wire connectors used in some computer circuits. They seal the wire terminals from the atmosphere, thereby preventing corrosion and other damage.

**Conector metri-pack** Los conectores de alambres especiales que se emplean en algunos circuitos de computadoras. Impermealizan los bornes de los alambres, así preveniendo la corrosión y otros daños.

**Millisecond** Equals 1/100th of a second.

**Milesegundos** Equivale a 1/100 de un segundo.

**Molded connector** An electrical connector that usually has one to four wires that are molded into a one-piece component.

**Conectador moldeado** Conectador eléctrico que por lo general tiene hasta un máximo cuatro alambres que se moldean en un componente de una sola pieza.

**MSDS** Material Safety Data Sheet.

**MSDS** Hojas de Dato de Seguridad de los Materiales.

**Multifunction switch** Can have a combination of any of the following switches in a single unit: headlights, turn signal, hazard, dimmer, horn, and flash to pass.

**Interruptor de múltiples funciones** Este permite lograr una combinación de cualquiera de los siguientes interruptores: faroles, señal de doblaje, peligro, interruptor reductor de luz, cuerno, señal de pasada a otro carril.

**Multimeter** A test instrument that measures more than one electrical property.

**Multímetro** Un instrumento diagnóstico que mide más de una propiedad eléctrica.

**Multiplying coil** Made of ten wraps of wire. This multiplies the ammeter reading so that the tester's scale can be used to read lower amperage. For example, if the needle is pointing to 25 amperes when using the multiplying coil, the actual reading is 2.50 amperes.

**Bobina múltiple** Está hecha de diez (10) cables enroscados. Esto multiplica la lectura del amperímetro y así la escala de prueba puede ser usada para ver si el amperaje está bajo. Por ejemplo, si la aguja está indicando 25 amperajes cuando se está usando la bobina múltiple la lectura actual es de 2.50 amperajes.

**Negative temperature coefficient (NTC)** Thermistors that their crystal structure reduces their resistance as the temperature increases.

**Coefficiente de temperatura negativa (NTC, por su sigla en inglés)** Termistores cuya estructura de cristal disminuye el valor de la resistencia eléctrica a medida que aumenta la temperatura.

**Neutral safety switch** A switch used to prevent the starting of an engine unless the transmission is in PARK or NEUTRAL.

**Disyuntor de seguridad en neutral** Un conmutador que se emplea para prevenir que arranque un motor al menos de que la transmisión esté en posición PARK o NEUTRAL.

**No-crank** A term used to mean that when the ignition switch is placed in the START position, the starter does not turn the engine.

**Sin arranque** Término utilizado para expresar que cuando el botón conmutador de encendido está en la posición START, el arrancador no enciende el motor.

**No-crank test** Diagnostic test performed to locate any opens in the starter or control circuits.

**Prueba sin arranque** Prueba diagnóstica llevada a cabo para localizar aberturas en los circuitos de arranque o de mando.

**Noise** An unwanted voltage signal that rides on a signal. Noise is usually the result of radio frequency interference (RFI) or electromagnetic induction (EMI).

**Ruido** Una señal indeseada del voltaje que aparece montada en una señal. El ruido es generalmente el resultado de la radio frecuencia de contacto (RFI) o de la inducción electromagnética (EMI).

**Normally closed (NC) switch** A switch designation denoting that the contacts are closed until acted upon by an outside force.

**Conmutador normalmente cerrado** Nombre aplicado a un conmutador cuyos contactos permanecerán cerrados hasta que sean accionados por una fuerza exterior.

**Normally open (NO) switch** A switch designation denoting that the contacts are open until acted upon by an outside force.

**Conmutador normalmente abierto** Nombre aplicado a un conmutador cuyos contactos permanecerán abiertos hasta que sean accionados por una fuerza exterior.

**NTC** Negative temperature coefficient.

**NTC** Las iniciales NTC representan la temperatura coeficiente negativa.

**OBD II** Stands for on-board diagnostics, second generation.

**OBD II** Las letras OBD II se refieren a los diagnósticos del tablero, segunda generación.

**Occupational safety glasses** Eye protection that is designed with special high-impact lens and frames, and side protection.

**Gafas de protección para el trabajo** Gafas diseñadas con cristales y monturas especiales resistentes y provistas de protección lateral.

**OCS service kit** An OCS part set that consists of the seat foam, the bladder, the pressure sensor, the occupant classification module (OCM), and the wiring. The service kit is calibrated as an assembly. The service kit OCM has a special identification data bit that is transmitted once it is connected.

**Kit de servicio SCO** Juego de partes SCO que consiste en la hule-espuma del asiento, el depósito, el sensor de presión, el módulo de clasificación del ocupante (MCO) y el alambrado. El kit de servicio está calibrado como un ensamblado. El kit de servicio SCO tiene un bit de datos de identificación especial que se transmiten cuando se haya conectado.

**OCS validation test** Special procedure that confirms the OCS can properly classify the occupant. This task usually requires the use of special weights.

**Prueba de revalidación del SCO** Procedimiento especial que confirma que el SCO puede clasificar apropiadamente al ocupante. Esta tarea generalmente requiere el uso de pesas especiales.

**Odometer** A mechanical counter in the speedometer unit that indicates total miles accumulated on the vehicle.

**Odómetro** Aparato mecánico en la unidad del velocímetro con el que se cuentan las millas totales recorridas por el vehículo.

**Offset** Placed off center. Refers to the number of degrees a timing light or meter should be set to provide accurate ignition timing readings.

**Desviación** Ubicado fuera de lo central. Se refiere al número de grados que se debe ajustar una luz de temporización o un medidor para proveer las lecturas exactas del tiempo de encendido.

**Ohm** Unit of measure for resistance. One ohm is the resistance of a conductor such that a constant current of one ampere in it produces a voltage of one volt between its ends.

**Ohmio** Unidad de resistencia eléctrica. Un ohmio es la resistencia de un conductor si una corriente constante de 1 amperio en el conductor produce una tensión de 1 voltio entre los dos extremos.

**Ohmmeter** A test meter used to measure resistance and continuity in a circuit.

**Ohmiómetro** Instrumento de prueba utilizado para medir la resistencia y la continuidad en un circuito.

**Ohm's law** Defines the relationship between current, voltage, and resistance.

**Leyle de Ohm** Define la relación entre la corriente, la tensión y la resistencia.

**Open** An electrical term used to indicate that the circuit is not complete or is broken.

**Abierto** Es un término de electricidad, usado para indicar que el circuito no está completo o está roto.

**Open circuit** A term used to indicate that current flow is stopped. By opening the circuit, the path for electron flow is broken.

**Circuito abierto** Término utilizado para indicar que el flujo de corriente ha sido detenido. Al abrirse el circuito, se interrumpe la trayectoria para el flujo de electrones.

**Open circuit voltage test** Used to determine the battery's state of charge. It is used when a hydrometer is not available or cannot be used.

**Prueba de la tensión en un circuito abierto** Sirve para determinar el estado de carga de la batería. Esta prueba se lleva a cabo cuando no se dispone de un hidrómetro o cuando el mismo no puede utilizarse.

**Optics test** Test of the automatic high-beam system to test the ability to recognize ambient light through the lens and the windshield.

**Prueba óptica** Prueba del sistema automático de luces altas para averiguar la habilidad de reconocer las luces ambientales mediante la lente y el parabrisas

**Overload** Excess current flow in a circuit.

**Sobrecarga** Flujo de corriente superior a la que tiene asignada un circuito.

**Overrunning clutch** A clutch assembly on a starter drive used to prevent the engine's flywheel from turning the armature of the starter motor.

**Embrague de sobremarcha** Una asamblea de embrague en un acoplamiento del motor de arranque que se emplea para prevenir que el volante del motor dé vueltas al armazón del motor de arranque.

**Oxygen sensor** A voltage generating sensor that measures the amount of oxygen present in an engine's exhaust.

**Sensor de oxígeno** Un sensor generador de tensión que mide la cantidad del oxígeno presente en el gas de escape de un motor.

**Parallel circuit** A circuit that provides two or more paths for electricity to flow.

**Circuito en paralelo** Circuito que provee dos o más trayectorias para que circule la electricidad.

**Parasitic drains** Constant drains on the battery due to accessories that draw small amounts of current.

**Drenaje parásita** Los constantes drenajes en la batería son causados debido a que los accesorios atraen pequeñas cantidades de corriente.

**Parasitic loads** Electrical loads that are still present when the ignition switch is in the OFF position.

**Cargas parásitas** Cargas eléctricas que todavía se encuentran presentes cuando el botón conmutador de encendido está en la posición OFF.

**Park switch** Contact points located inside the wiper motor assembly that supply current to the motor after the wiper control switch has been

turned to the PARK position. This allows the motor to continue operating until the wipers have reached their PARK position.

**Conmutador PARK** Puntos de contacto ubicados dentro del conjunto del motor del frotador que le suministran corriente al motor después de que el conmutador para el control de los frotadores haya sido colocado en la posición PARK. Esto permite que el motor continúe su funcionamiento hasta que los frotadores hayan alcanzado la posición original.

**Passive seat belt system** Seat belt operation that automatically puts the shoulder and/or lap belt around the driver or occupant. The automatic seat belt is moved by DC motors that move the belts by means of carriers on tracks.

**Sistema pasivo de cinturones de seguridad** Función de los cinturones de seguridad que automáticamente coloca el cinturón superior y/o inferior sobre el conductor o pasajero. Motores de corriente continua accionan los cinturones automáticos mediante el uso de portadores en pistas.

**Peak** The highest voltage value in one cycle of an AC voltage sine wave.

**Máxima eficiencia** El valor más alto del voltaje de un ciclo de corriente alterna (AC) en un voltaje de onda senoidal.

**Peak-to-peak voltage** The total voltage measured between the peaks of an AC sine wave.

**Voltaje de máximas eficiencias** La medida total del voltaje cuando los puntos son de máxima eficiencia en una onda senoidal de corriente alterna (AC).

**Photocell** A variable resistor that uses light to change resistance.

**Fotocélula** Resistor variable que utiliza luz para cambiar la resistencia.

**Photocell resistance assembly** A technician-made test tool that replaces the photocell to produce predictable results.

**Montaje de resistencia fotocélula** Una herramienta técnica de prueba que reemplaza la fotocélula para producir resultados visibles.

**Phototransistor** A transistor that is sensitive to light.

**Fototransistor** Transistor sensible a la luz.

**Photovoltaic diodes** Diodes capable of producing a voltage when exposed to radiant energy.

**Diodos fotovoltaicos** Diodos capaces de generar una tensión cuando se encuentran expuestos a la energía de radiación.

**Pick-up coil** The stationary component of the magnetic pulse generator consisting of a weak permanent magnet that is wound around by fine wire. As the timing disc rotates in front of it, the changes of magnetic lines of force generate a small voltage signal in the coil.

**Bobina captadora** Componente fijo del generador de impulsos magnéticos compuesta de un imán permanente débil devanado con alambre fino. Mientras gira el disco sincronizador enfrente de él, los cambios de las líneas de fuerza magnética generan una pequeña señal de tensión en la bobina.

**Piezoelectric sensors** Produce a proportional voltage output resulting from deformation of the element as pressure is applied.

**Sensores piezoeléctricos** Producen una salida de voltaje proporcional que es el resultado de una deformación del elemento a medida que se aplica presión.

**Piezoelectric transducer** A sensor that is capable of measuring the pressures associated with ultrasonic waves

**Transductor piezoeléctrico** Un sensor capaz de medir las presiones relacionadas con las ondas ultrasónicas.

**Piezoresistive** A piezoresistive sensor changes in resistance value as the pressure applied to the sensing material changes.

**Sensor piezoresistivo** Sensor susceptible a los cambios de presión.

**Pinion gear** A small gear; typically refers to the drive gear of a starter drive assembly or the small drive gear in a differential assembly.

**Engranaje de piñón** Un engranaje pequeño; típicamente se refiere al engranaje de arranque de una asamblea de motor de arranque o al engranaje de mando pequeño de la asamblea del diferencial.

**Pinpoint test** A specific component test.

**Prueba de precisión** Una prueba hecha con un componente específico.

**Plate straps** Metal connectors used to connect the positive or negative plates in a battery.

**Abrazaderas de la placa** Los conectores metálicos que sirven para conectar las placas positivas o negativas de una batería.

**Plates** The basic structure of a battery cell; each cell has at least one positive plate and one negative plate.

**Placas** La estructura básica de una célula de batería; cada célula tiene al menos una placa positiva y una placa negativa.

**PMGR** An abbreviation for permanent magnet gear reduction.

**PMGR** Una abreviación de desmultiplicación del engranaje del imán permanente.

**Pneumatic tools** Power tools that are powered by compressed air.

**Herramientas neumáticas** Herramientas mecánicas accionadas por aire comprimido.

**Polarizers** Glass sheets that make light waves vibrate in only one direction. This converts light into polarized light.

**Polarizadores** Las láminas de vidrio que hacen vibrar las ondas de luz en un sólo sentido. Esto convierte la luz en luz polarizada.

**Polarizing** The process of light polarization or of setting one end of a field as a positive or negative point.

**Polarizadora** El proceso de polarización de la luz o de establecer un lado de un campo como un punto positivo o negativo.

**Polymer** Compound that consists of a plastic with carbon grains

**Polímero** Compuesto fabricado a partir de un plástico con granos de carbón.

**Positive engagement starter** A type of starter that uses the magnetic field strength of a field winding to engage the starter drive into the flywheel.

**Acoplamiento de arranque positivo** Un tipo de arrancador que utiliza la fuerza del campo magnético del devanado inductor para accionar el acoplamiento del arrancador en el volante.

**Positive temperature coefficient (PTC)** Thermistors that increase their resistance as the temperature increases.

**Coefficiente de temperatura positiva (PTC, por su sigla en inglés)** Termistores que aumentan su resistencia a medida que aumenta la temperatura.

**Potential** The ability to do something; typically voltage is referred to as the potential. If you have voltage, you have the potential for electricity.

**Potencial** La capacidad de efectuar el trabajo; típicamente se refiere a la tensión como el potencial. Si tiene tensión, tiene la potencial para la electricidad.

**Potentiometer** A voltage divider circuit that is used to measure linear or rotary movement.

**Potenciómetro** Un circuito divisor de voltaje que se utiliza para medir el movimiento lineal o rotativo.

**Potentiometer** A variable resistor that acts as a circuit divider, providing accurate voltage drop readings proportional to movement.

**Potenciómetro** Resistor variable que actúa como un divisor de circuito para obtener lecturas de pérdidas de tensión precisas en proporción con el movimiento.

**Power formula** A formula used to calculate the amount of electrical power a component uses. The formula is  $P = I \times E$ , where P stands for power (measured in watts), I stands for current, and E stands for voltage.

**Formula de potencia** Una fórmula que se emplea para calcular la cantidad de potencia eléctrica utilizada por un componente. La fórmula es  $P = I \times E$ , en el que el P quiere decir potencia (medida en wats), I representa el corriente y el E representa la tensión.

**Power tools** Tools that use forces other than those generated from the body. They can use compressed air, electricity, or hydraulic pressure to generate and multiply force.

**Herramientas mecánicas** Herramientas que utilizan fuerzas distintas a las generadas por el cuerpo. Dichas fuerzas pueden ser el aire comprimido, la electricidad, o la presión hidráulica para generar y multiplicar la fuerza.

**Power train control module (PCM)** The computer that controls the engine operation.

**Módulo de control de potencia** El computador que controla la operación del motor.

**Pressure control solenoid** A solenoid used to control the pressure of a fluid, commonly found in electronically controlled transmissions.

**Solenoido de control de la presión** Un solenoide que controla la presión de un fluido, suele encontrarse en las transmisiones controladas electrónicamente.

**Primary wiring** Conductors that carry low voltage and low current. The insulation of primary wires is usually thin.

**Hilos primarios** Hilos conductores de tensión y corriente bajas. El aislamiento de hilos primarios es normalmente delgado.

**Program** A set of instructions that the computer must follow to achieve desired results.

**Programa** Conjunto de instrucciones que la computadora debe seguir para lograr los resultados deseados.

**PROM (programmable read only memory)** Memory chip that contains specific data that pertains to the exact vehicle that the computer is installed in. This information may be used to inform the CPU of the accessories that are equipped on the vehicle.

**PROM (memoria de sólo lectura programable)** Fragmento de memoria que contiene datos específicos referentes al vehículo particular en el que se instala la computadora. Esta información puede utilizarse para informar a la UCP sobre los accesorios de los cuales el vehículo está dotado.

**Protection device** Circuit protector that is designed to “turn off” the system that it protects. This is done by creating an open to prevent a complete circuit.

**Dispositivo de protección** Protector de circuito diseñado para “desconectar” el sistema al que provee protección. Esto se hace abriendo el circuito para impedir un circuito completo.

**Prove-out circuit** A function of the ignition switch that completes the warning light circuit to ground through the ignition switch when it is in the START position. The warning light is on during engine cranking to indicate to the driver that the bulb is working properly.

**Circuito de prueba** Función del botón conmutador de encendido que completa el circuito de la luz de aviso para que se ponga a tierra a través del botón conmutador de encendido cuando éste se encuentra en la posición START. La luz de aviso se encenderá durante el arranque del motor para avisarle al conductor que la bombilla funciona correctamente.

**PTC** Positive temperature coefficient.

**PTC** Iniciales identificadoras de la temperatura positiva coeficiente.

**Pull to seat** A method used to install the terminals into the connector.



**Tire el asiento** Un método usado para instalar los terminales dentro del conector.

**Pulse width** The length of time in milliseconds that an actuator is energized.

**Duración de impulsos** Espacio de tiempo en milisegundos en el que se excita un accionador.

**Pulse width modulation** On/off cycling of a component. The period of time for each cycle does not change, only the amount of on time in each cycle changes.

**Modulación de duración de impulsos** Modulación de impulsos de un componente. El espacio de tiempo de cada ciclo no varía; lo que varía es la cantidad de trabajo efectivo de cada ciclo.

**Push to seat** A method used to install the terminals into the connector.

**Empuje el asiento** Un método usado para instalar los terminales dentro del conector.

**Quartz swing needle** Displays that are similar in design to the air core electromagnetic gauges used in conventional analog instrument panels.

**Aguja de oscilación del cuarzo** Mostrarios que son similares en diseño al del núcleo de aire de los calibres electromagnéticos usados convencionalmente en los paneles de instrumentos análogos.

**Quick test** Isolates the problem area and determines whether the starter motor, solenoid, or control circuit is at fault.

**Prueba rápida** Aísla el área con problemas y determina si el arrancador del motor, el solenoide, y el circuito de control están fallando.

**Radial grid** A type of battery grid that has its patterns branching out from a common center.

**Rejilla radial** Un tipo de rejilla de batería cuyos diseños extienden de un centro común.

**Radio choke** Absorbs voltage spikes and prevents static in the vehicle's radio.

**Impedancia del radio** Absorba los impulsos de la tensión y previene la presencia del estático en el radio del vehículo.

**Radio frequency interface (RFI)** Produced when electromagnetic radio waves of sufficient amplitude escape from a wire or connector.

**Radio frecuencia de contacto (RFI)** Se produce cuando las ondas de radio electromagnéticas y de suficiente amplitud se escapan de un cable o conector.

**Ratio** A mathematical relationship between two or more things.

**Razón** Una relación matemática entre dos cosas o más.

**Rectification** The converting of AC current to DC current.

**Rectificación** Proceso a través del cual la corriente alterna es transformada en una corriente continua.

**Refractometer** A special meter used to measure the specific gravity of a liquid by the refraction of light.

**Refractómetro** Herramienta especial que usa para medir la gravedad específica de un líquido por la refracción de la luz.

**Relative compression testing** A test method for determining if a cylinder has lower compression relative to other cylinders by using current draw during cranking.

**Prueba de compresión relativa** Método de prueba para determinar si un cilindro tiene compresión más baja comparada a los otros cilindros al utilizar llamada de corriente durante la desengoladura.

**Relay** A device that uses low current to control a high-current circuit. Low current is used to energize the electromagnetic coil, while high current is able to pass over the relay contacts.

**Relé** Dispositivo que utiliza corriente baja para controlar un circuito de corriente alta. La corriente baja se utiliza para excitar la bobina

electromagnética, mientras que la corriente alta puede transmitirse a través de los contactos del relé.

**Reserve-capacity rating** An indicator, in minutes, of how long the vehicle can be driven with the headlights on, if the charging system should fail. The reserve-capacity rating is determined by the length of time, in minutes, that a fully charged battery can be discharged at 25 amperes before battery cell voltage drops below 1.75 volts per cell.

**Clasificación de capacidad en reserva** Indicación, en minutos, de cuánto tiempo un vehículo puede continuar siendo conducido, con los faros delanteros encendidos, en caso de que ocurriese una falla en el sistema de carga. La clasificación de capacidad en reserva se determina por el espacio de tiempo, en minutos, en el que una batería completamente cargada puede descargarse a 25 amperios antes de que la tensión del acumulador de la batería disminuya a un nivel inferior de 1,75 amperios por acumulador.

**Resource Conservation and Recovery Act (RCRA)** Law that makes hazardous waste generators responsible for the waste from the time it becomes a waste material until the proper waste disposal is completed.

**Ley de la Conservación y Recuperación de los Recursos** Ley que hace responsables a los que generan residuos peligrosos por su desecho desde el momento en que se convierte en material de desecho hasta que se completa su destrucción apropiada de desechos.

**Resistance** Opposition to current flow.

**Resistencia** Oposición que presenta un conductor al paso de la corriente eléctrica.

**Resistance wire** A special type of wire that has some resistance built into it. These typically are rated by ohms per foot.

**Alambre de resistencia** Un tipo de alambre especial que por diseño tiene algo de resistencia. Estos típicamente tienen un valor nominal de ohm por pie.

**Resistive shorts** Shorts to ground that pass through a form of resistance first.

**Cortocircuitos resistivos** Cortocircuitos a tierra que primero pasan por una forma de resistencia.

**Resistor block** A series of resistors with different values.

**Bloque resistor** Serie de resistores que tienen valores diferentes.

**Reversed-bias** A positive voltage is applied to the N-type material and negative voltage is applied to the P-type material of a semiconductor.

**Polarización inversa** Tensión positiva aplicada al material N y tensión negativa aplicada al material P de un semiconductor.

**RFI** Common acronym for radio frequency interference.

**RFI** Una sigla común de la interferencia de radiofrecuencia.

**Rheostat** A two-terminal variable resistor used to regulate the strength of an electrical current.

**Reostático** Un resistor variable de dos terminales usado para regular la potencia de un circuito eléctrico.

**Right-to-know laws** Laws concerning hazardous materials and wastes that protect every employee in a workplace by requiring employers to provide a safe working place as it relates to hazardous materials. The right-to-know laws state that employees have a right to know when the materials they use at work are hazardous.

**Leyes de derecho de información** Leyes contra materiales peligrosos y desechos que protegen a cada empleado en un lugar de trabajo al requerir que los patrones proporcionen un lugar de trabajo seguro contra los materiales peligrosos. Las leyes de derecho de información declaran que los empleados tienen derecho a saber cuando y qué materiales que usan en el trabajo son peligrosos.

**RMS** Root-mean-square; a method for measuring AC voltage.

**RMS** Raíz de la media de los cuadrados; un método para medir la tensión del corriente alterna.

**Root mean square (RMS)** Meters convert the AC signal to a comparable DC voltage signal.

**Corriente efectiva (RMS)** Los medidores convierten la señal de corriente alterna (AC) a una señal de voltaje comparable (DC).

**Rotor** The component of the AC generator that is rotated by the drive belt and creates the rotating magnetic field of the AC generator.

**Rotor** Parte rotativa del generador de corriente alterna accionada por la correa de transmisión y que produce el campo magnético rotativo del generador de corriente alterna.

**Safety goggles** Eye protection device that fits against the face and forehead to seal off the eyes from outside elements.

**Gafas de seguridad** Dispositivo protector que se coloca delante de los ojos para preservarlos de elementos extraños.

**Safety stands** See Jack stands.

**Soportes de seguridad** Véase soportes de gato.

**Scanner** A diagnostic test tool that is designed to communicate with the vehicle's on-board computer.

**Dispositivo de exploración** Herramienta de prueba diagnóstica diseñada para comunicarse con la computadora instalada en el vehículo.

**Scan tool** A microprocessor designed to communicate with the BCM. It will access trouble codes, run system operation, actuator, and sensor tests.

**Herramienta analizadora** Un microprocesador diseñado para comunicarse usando la información de las iniciales BCM. Así se encuentran los códigos que indican problemas, cómo funciona el sistema de conducción, los actuadores y monitores de prueba.

**Sealed-beam headlight** A self-contained glass unit that consists of a filament, an inner reflector, and an outer glass lens.

**Faro delantero sellado** Unidad de vidrio que contiene un filamento, un reflector interior y una lente exterior de vidrio.

**Secondary wiring** Conductors, such as battery cables and ignition spark plug wires, that are used to carry high voltage or high current. Secondary wires have extra-thick insulation.

**Hilos secundarios** Conductores, tales como cables de batería e hilos de bujías del encendido, utilizados para transmitir tensión o corriente alta. Los hilos secundarios poseen un aislamiento sumamente grueso.

**Self-test input (STI)** The single pigtail connector located next to the self-test connector.

**Autopruueba de entrada (STI)** Simple cable flexible de conexión localizado junto al conector de autopruueba.

**Semiconductors** An element that is neither a conductor nor an insulator. Semiconductors are materials that conduct electric current under certain conditions, yet will not conduct under other conditions.

**Semiconductores** Elemento que no es ni conductor ni aislante. Los semiconductores son materiales que transmiten corriente eléctrica bajo ciertas circunstancias, pero no la transmiten bajo otras.

**Sender unit** The sensor for the gauge. It is a variable resistor that changes resistance values with changing monitored conditions.

**Unidad emisora** Sensor para el calibrador. Es un resistor variable que cambia los valores de resistencia según cambian las condiciones reguladas.

**Sensitivity controls** A potentiometer that allows the driver to adjust the sensitivity of the automatic dimmer system to surrounding ambient light conditions.

**Controles de sensibilidad** Un potenciómetro que permite que el conductor ajusta la sensibilidad del sistema de intensidad de iluminación automático a las condiciones de luz ambientales.

**Sensor** Any device that provides an input to the computer.

**Sensor** Cualquier dispositivo que le transmite información a la computadora.

**Sensor dropout** When an induction sensor stops producing an output voltage due to slow speeds of the target.

**Desenganche del sensor** Cuando un sensor de inducción deja de producir voltaje de salida debido a velocidades bajas del objetivo.

**Series circuit** A circuit that provides a single path for current flow from the electrical source through all the circuit's components, and back to the source.

**Circuito en serie** Circuito que provee una trayectoria única para el flujo de corriente de la fuente eléctrica a través de todos los componentes del circuito, y de nuevo hacia la fuente.

**Series-parallel circuit** A circuit that has some loads in series and some in parallel.

**Circuito en series paralelas** Circuito que tiene unas cargas en serie y otras en paralelo.

**Series-wound motor** A type of motor that has its field windings connected in series with the armature. This type of motor develops its maximum torque output at the time of initial start. Torque decreases as motor speed increases.

**Motor con devanados en serie** Un tipo de motor cuyos devanados inductores se conectan en serie con la armadura. Este tipo de motor desarrolla la salida máxima de par de torsión en el momento inicial de ponerse en marcha. El par de torsión disminuye al aumentar la velocidad del motor.

**Servo** Controls the position of the throttle by receiving a controlled amount of vacuum.

**Control servo** Este sirve para controlar la posición de la válvula reguladora al recibir una cantidad controlada de vacío.

**Servomotor** An electrical motor that produces rotation of less than a full turn. A feedback mechanism is used to position itself to the exact degree of rotation required.

**Servomotor** Motor eléctrico que genera rotación de menos de una revolución completa. Utiliza un mecanismo de realimentación para ubicarse al grado exacto de la rotación requerida.

**Short** An unwanted electrical path; sometimes this path goes directly to ground.

**Corto** Una trayectoria eléctrica no deseable; a veces este trayectoria viaja directamente a tierra.

**Shorted circuit** Allows current to bypass part of the normal path.

**Circuito corto** Este circuito permite que la corriente pase por una parte del recorrido normal.

**Short to ground** A condition that allows current to return to ground before it has reached the intended load component.

**Corto a la tierra** Su función permite que la corriente regrese a la tierra, antes de que haya llegado a un componente intencionalmente cargado.

**Shunt-wound motor** A type of motor whose field windings are wired in parallel to the armature. This type of motor does not decrease its torque as speed increases.

**Motor con devanados en derivación** Un tipo de motor cuyos devanados inductores se cablean paralelos a la armadura. Este tipo de motor no disminuya su par de torsión al aumentar la velocidad.

**Shutter wheel** A metal wheel consisting of a series of alternating windows and vanes. It creates a magnetic shunt that changes the

strength of the magnetic field from the permanent magnet of the Hall-effect switch or magnetic pulse generator.

**Rueda obturadora** Rueda metálica compuesta de una serie de ventanas y aspas alternas. Genera una derivación magnética que cambia la potencia del campo magnético, del imán permanente del conmutador de efecto Hall o del generador de impulsos magnéticos.

**Sine wave** A waveform that shows voltage changing polarity.

**Onda senoidal** Una forma de onda que muestra un cambio de polaridad en la tensión.

**Single phase voltage** The sine wave voltage induced in one conductor of the stator during one revolution of the rotor.

**Tensión monofásica** La tensión en forma de onda senoidal inducida en un conductor del estator durante una revolución del rotor.

**Sinusoidal** A waveform that is a true sine wave.

**Senoidal** Una forma de onda que es una onda senoidal verdadera.

**Slow charging** Battery charging rate between 3 and 15 amps for a long period of time.

**Carga lenta** Índice de carga de la batería de entre 3 y 15 amperios por un largo espacio de tiempo.

**Slow cranking** A term used to mean that the starter drive engages the ring gear, but the engine turns too slowly to start.

**Arranque lento** Término utilizado para expresar que el mecanismo de transmisión de arranque engrana la corona, pero que el motor se enciende de forma demasiado lenta para arrancar.

**Soft codes** Codes are those that have occurred in the past, but were not present during the last BCM test of the circuit.

**Códigos suaves** Códigos que han ocurrido en el pasado, pero que no estaban presentes durante la última prueba BCM del circuito.

**Soldering** The process of using heat and solder (a mixture of lead and tin) to make a splice or connection.

**Soldadura** Proceso a través del cual se utiliza calor y soldadura (una mezcla de plomo y de estaño) para hacer un empalme o una conexión.

**Solderless connectors** Hollow metal tubes that are covered with insulating plastic. They can be butt connectors or terminal ends.

**Conectores sin soldadura** Tubos huecos de metal cubiertos de plástico aislante. Pueden ser extremos de conectores o de bornes.

**Solenoid** An electromagnetic device that uses movement of a plunger to exert a pulling or holding force.

**Solenoid** Dispositivo electromagnético que utiliza el movimiento de un pulsador para ejercer una fuerza de arrastre o de retención.

**Solenoid circuit resistance test** Diagnostic test used to determine the electrical condition of the solenoid and the control circuit of the starting system.

**Prueba de la resistencia de un circuito solenoide** Prueba diagnóstica utilizada para determinar la condición eléctrica del solenoide y del circuito de mando del sistema de arranque.

**Spark tester** A special tool used to provide a quick way to check ignition spark.

**Probador de bujía** Herramienta especial que se utiliza para proporcionar una manera rápida de revisar la bujía de encendido.

**Specific gravity** The weight of a given volume of a liquid divided by the weight of an equal volume of water.

**Gravedad específica** El peso de un volumen dado de líquido dividido por el peso de un volumen igual de agua.

**Speedometer** An instrument panel gauge that indicates the speed of the vehicle.

**Velocímetro** Calibrador en el panel de instrumentos que marca la velocidad del vehículo.

**Splice** The joining of single wire ends or the joining of two or more electrical conductors at a single point.

**Empalme** La unión de los extremos de un alambre o la unión de dos o más conductores eléctricos en un solo punto.

**Splice clip** A special connector used along with solder to assure a good connection. The splice clip is different from solderless connectors in that it does not have insulation.

**Grapa para empalme** Conector especial utilizado junto con la soldadura para garantizar una conexión perfecta. La grapa para empalme se diferencia de los conectores sin soldadura porque no está provista de aislamiento.

**Square waves** Identified by having straight vertical sides and a flat top.

**Ondas cuadradas** Para saber cuáles son, deben tener lados rectos verticales y una punta plana.

**Stabilize** Removing the surface charge of the battery by placing a large load on the battery for 15 seconds.

**Estabilizar** Para hacerlo hay que remover la superficie cargada de la batería, colocando en la batería, por 15 segundos, una carga grande.

**Starter drive** The part of the starter motor that engages the armature to the engine flywheel ring gear.

**Transmisión de arranque** Parte del motor de arranque que engrana la armadura a la corona del volante de la máquina.

**State of charge** The condition of a battery's electrolyte and plate materials at any given time.

**Estado de carga** Condición del electrolito y de los materiales de la placa de una batería en cualquier momento dado.

**Stator** The stationary coil of the AC generator in which current is produced.

**Estátor** Bobina fija del generador de corriente alterna donde se genera corriente.

**Stator neutral junction** The common junction of Wye stator windings.

**Unión de estátor neutral** La unión común de los devanados de un estátor Y.

**Stepped resistor** A resistor that has two or more fixed resistor values.

**Resistor de secciones escalonadas** Resistor que tiene dos o más valores de resistencia fija.

**Stepper motor** An electrical motor that contains a permanent magnet armature with two or four field coils. Can be used to move the controlled device to whatever location is desired. By applying voltage pulses to selected coils of the motor, the armature will turn a specific number of degrees. When the same voltage pulses are applied to the opposite coils, the armature will rotate the same number of degrees in the opposite direction.

**Motor paso a paso** Motor eléctrico que contiene una armadura magnética fija con dos o cuatro bobinas inductoras. Puede utilizarse para mover el dispositivo regulado a cualquier lugar deseado. Al aplicársele impulsos de tensión a ciertas bobinas del motor, la armadura girará un número específico de grados. Cuando estos mismos impulsos de tensión se aplican a las bobinas opuestas, la armadura girará el mismo número de grados en la dirección opuesta.

**Sulfation** A chemical action within the battery that interferes with the ability of the cells to deliver current and accept a charge.

**Sulfatado** Acción química dentro de la batería que interfiere con la capacidad de los acumuladores de transmitir corriente y recibir una carga.

**System main relay (SMR)** Used to connect and disconnect the power source of the high-voltage system in an HEV.

**Relé principal del sistema del (SMR o RPS)** Se usa para conectar y desconectar la fuente de potencia del sistema de alto voltaje en un VHE.

**Tachometer** An instrument that measures the speed of the engine in revolutions per minute (rpm).

**Tacómetro** Instrumento que mide la velocidad del motor en revoluciones por minuto (rpm).

**Thermistor** A solid-state variable resistor made from a semiconductor material that changes resistance as a function of temperature.

**Termistor** Un resistor variable de estado sólido, fabricado a partir de material semiconductor que cambia la resistencia en función de la temperatura.

**Test light** Checks for electrical power in a circuit.

**Luz de prueba** Verifica la potencia eléctrica en un circuito.

**Three-coil gauge** A gauge design that uses the interaction of three electromagnets and the total field effect upon a permanent magnet to cause needle movement.

**Calibrador de tres bobinas** Calibrador diseñado para utilizar la interacción de tres electroimanes y el efecto inductor total sobre un imán permanente para producir el movimiento de la aguja.

**Three-minute charge test** A reasonably accurate method for diagnosing a sulfated battery for use on conventional batteries.

**Prueba de carga de tres minutos** Método bastante preciso en baterías convencionales para diagnosticar una batería sulfatada.

**Throttle position sensor (TPS)** Sensor used to modify the pulse width calculation based on position of the throttle plate and the rate of change of the throttle plate.

**Sensor de posición del acelerador (TPS, por sus siglas en inglés)** Sensor que se utiliza para modificar el cálculo de la amplitud del pulso sobre la base de la posición de la placa del acelerador y el índice de cambio de la placa del acelerador.

**Timer control** A potentiometer that is part of the headlight switch in some systems. It controls the amount of time the headlights stay on after the ignition switch is turned off.

**Control temporizador** Un potenciómetro que es parte del conmutador de los faros en algunos sistemas. Controla la cantidad de tiempo que quedan prendidos los faros después de apagarse la llave del encendido.

**Tin** Process of applying solder to the tip of the soldering iron to provide better heating control.

**Estaño** El proceso de aplicar soldadura en la punta de un hierro soldador para dar mejor control al calor.

**Tire pressure monitoring (TPM) system** A safety system that notifies the driver if a tire is underinflated or overinflated.

**Sistema de monitoreo de presión de las llantas (TPM, por su sigla en inglés)** Un sistema de seguridad que informa al conductor si una llanta está muy inflada o poco inflada.

**Torque converter** A hydraulic device found on automatic transmissions. It is responsible for controlling the power flow from the engine to the transmission; works like a clutch to engage and disengage the engine's power to the drive line.

**Convertidor de par** Un dispositivo hidráulico en las transmisiones automáticas. Se encarga de controlar el flujo de la potencia del motor a la transmisión; funciona como un embrague para embragar y desembragar la potencia del motor con la flecha motriz.

**Trimotor** A three-armature motor.

**Trimotor** Es un motor de tres armaduras.

**Trouble codes** Output of the self-diagnostics program in the form of a numbered code that indicates faulty circuits or components. Trouble codes are two or three digital characters that are displayed in the diagnostic display if the testing and failure requirements are both met.

**Códigos indicadores de fallas** Datos del programa autodiagnóstico en forma de código numerado que indica los circuitos o los componentes defectuosos. Dichos códigos se componen de dos o tres caracteres digitales que se muestran en el visualizador diagnóstico si se llenan los requisitos de prueba y de falla.

**Troubleshooting** The diagnostic procedure of locating and identifying the cause of the fault. It is a step-by-step process of elimination by use of cause-and-effect.

**Detección de fallas** Procedimiento diagnóstico a través del cual se localiza e identifica la falla. Es un proceso de eliminación que se lleva a cabo paso a paso por medio de causa y efecto.

**TVRS** An abbreviation for television-radio-suppression cable.

**TVRS** Una abreviación del cable de supresión del televisión y radio.

**Two-button diagnostics** The buttons on the instrument panel that, when pressed in the right combination, place the module into self-test mode.

**Diagnósticos de dos botones** Estos son los botones que aparecen en el panel de instrumentos, los cuales al presionarlos en la combinación correcta, ponen el módulo en estado de autoprueba.

**Two-coil gauge** A gauge design that uses the interaction of two electromagnets and the total field effect upon an armature to cause needle movement.

**Calibrador de dos bobinas** Calibrador diseñado para utilizar la interacción de dos electroimanes y el efecto inductor total sobre una armadura para generar el movimiento de la aguja.

**U-codes** Diagnostic trouble codes assigned to the vehicle communication network.

**Códigos en U** Códigos de fallo de diagnóstico asignados a la red de comunicación del vehículo.

**Vacuum distribution valve** A valve used in vacuum-controlled concealed headlight systems. It controls the direction of vacuum to various vacuum motors or to vent.

**Válvula de distribución al vacío** Válvula utilizada en el sistema de faros delanteros ocultos controlado al vacío. Regula la dirección del vacío a varios motores al vacío o sirve para dar salida del sistema.

**Vacuum fluorescent display (VFD)** A display type that uses anode segments coated with phosphor and bombarded with tungsten electrons to cause the segments to glow.

**Visualización de fluorescencia al vacío** Tipo de visualización que utiliza segmentos ánodos cubiertos de fósforo y bombardeados de electrones de tungsteno para producir la luminiscencia de los segmentos.

**Valve body** A unit that consists of many valves and hydraulic circuits. This unit is the central control point for gear shifting in an automatic transmission.

**Cuerpo de la válvula** Una unidad que consiste de muchas válvulas y circuitos hidráulicos. Esta unidad es el punto central de mando para los cambios de velocidad en una transmisión automática.

**Variable resistor** A resistor that provides for an infinite number of resistance values within a range.

**Resistor variable** Resistor que provee un número infinito de valores de resistencia dentro de un margen.



**Vehicle Identification Number (VIN)** A number that is assigned to a vehicle for identification purposes. The identification plate is usually located on the cowl, next to the left upper instrument panel.

**Número de identificación del vehículo** Número asignado a cada vehículo para fines de identificación. Por lo general, la placa de identificación se ubica en la bóveda, al lado del panel de instrumentos superior de la izquierda.

**Vehicle lift points** The areas that the manufacturer recommends for safe vehicle lifting. They are the areas that are structurally strong enough to sustain the stress of lifting.

**Puntos para elevar el vehículo** Áreas específicas que el fabricante recomienda para sujetar el vehículo a fin de lograr una elevación segura. Son las áreas del vehículo con una estructura suficientemente fuerte para sostener la presión de la elevación.

**Vehicle module scan** A special function of the scan tools that will query all of the modules on the bus to respond and then list those that did reply.

**Explorador del módulo del vehículo** Función especial de los instrumentos de exploración que cuestionarán a todos los módulos en el bus para que respondan, y luego harán una lista de aquellos que respondieron.

**Volatile** A substance that vaporizes or explodes easily.

**Volátil** Sustancia que se evapora o explota con facilidad.

**Volatility** The tendency for a fluid to evaporate quickly or pass off in the form of a vapor.

**Volatilidad** La tendencia de un fluido a evaporarse rápidamente o dispersarse en forma de vapor.

**Volt** The unit used to measure the amount of electrical force.

**Voltio** Unidad práctica de tensión para medir la cantidad de fuerza eléctrica.

**Voltage** The difference or potential that indicates an excess of electrons at the end of the circuit the farthest from the electromotive force. It is the electrical pressure that causes electrons to move through a circuit. One volt is the amount of pressure required to move one amp of current through one ohm of resistance.

**Tensión** Diferencia o potencial que indica un exceso de electrones al punto del circuito que se encuentra más alejado de la fuerza electromotriz. La presión eléctrica genera el movimiento de electrones a través de un circuito. Un voltio equivale a la cantidad de presión requerida para mover un amperio de corriente a través de un ohmio de resistencia.

**Voltage drop** A resistance in the circuit that reduces the electrical pressure available after the resistance. The resistance can be either the load component, the conductors, any connections, or unwanted resistance.

**Caída de tensión** Resistencia en el circuito que disminuye la presión eléctrica disponible después de la resistencia. La resistencia puede ser el componente de carga, los conductores, cualquier conexión o resistencia no deseada.

**Voltage drop test** Determines if the battery, regulator, and AC generator are all operating at the same potential.

**Prueba de la caída de tensión en el voltaje** Determina si la batería, el regulador, y el generador de corriente alterna AC están todos funcionando al mismo potencial.

**Voltage limiter** Connected through the resistor network of a voltage regulator. It determines whether the field will receive high, low, or no voltage. It controls the field voltage for the required amount of charging.

**Limitador de tensión** Conectado por el red de resistores de un regulador de tensión. Determina si el campo recibirá alta, baja o ninguna tensión. Controla la tensión de campo durante el tiempo indicado de carga.

**Voltage output test** Used to make a quick determination about whether or not the charging system is working properly. If the charging system is operating correctly, then check for battery drain.

**Prueba de salida del voltaje** Se usa para determinar en forma rápida si el sistema de carga está trabajando correctamente. Si el sistema de carga está funcionando correctamente, entonces revíselo todo para saber si hay algún drenaje en la batería.

**Voltage regulator** Used to control the output voltage of the AC generator, based on charging system demands, by controlling field current.

**Regulador de tensión** Dispositivo cuya función es mantener la tensión de salida del generador de corriente alterna, de acuerdo a las variaciones en la corriente de carga, controlando la corriente inductora.

**Voltmeter** A test meter used to read the pressure behind the flow of electrons.

**Voltímetro** Instrumento de prueba utilizado para medir la presión del flujo de electrones.

**Warning light** A lamp that is illuminated to warn the driver of a possible problem or hazardous condition.

**Luz de aviso** Lámpara que se enciende para avisarle al conductor sobre posibles problemas o condiciones peligrosas.

**Watt** The unit of measure of electrical power, which is the equivalent of horsepower. One horsepower is equal to 746 watts.

**Watio** Unidad de potencia eléctrica, equivalente a un caballo de vapor. 746 wátios equivalen a un caballo de vapor (CV).

**Wattage** A measure of the total electrical work being performed per unit of time.

**Vataje** Medida del trabajo eléctrico total realizado por unidad de tiempo.

**Waveform** The electronic trace that appears on a scope; it represents voltage over time.

**Forma de onda** La trayectoria electrónica que aparece en un osciloscopio; representa la tensión a través del tiempo.

**Weather-pack connector** An electrical connector that has rubber seals on the terminal ends and on the covers of the connector half to protect the circuit from corrosion.

**Conector resistente a la intemperie** Conector que tiene sellos de caucho en los extremos de los bornes y en las cubiertas de la parte del conector para proteger el circuito contra la corrosión.

**Wet fouling** A condition of a spark plug in which it is wet with oil.

**Engrase húmedo** Una condición de la bujía en la cual se moja de aceite.

**Wheatstone bridge** A series-parallel arrangement of resistors between an input terminal and ground. Flexing of the disc the resistors are laid upon changes their value.

**Puente Wheatstone** Una disposición en serie paralela de resistores entre un terminal de entrada y la tierra. La flexión del disco en el que están colocados los resistores cambia su valor.

**Wiring diagram** An electrical schematic that shows a representation of actual electrical or electronic components and the wiring of the vehicle's electrical systems.

**Esquema de conexiones** Esquema en el que se muestran las conexiones internas de los componentes eléctricos o electrónicos reales y las de los sistemas eléctricos del vehículo.

**Wiring harness** A group of wires enclosed in a conduit and routed to specific areas of the vehicle.

**Cableado preformado** Conjunto de alambres envueltos en un conducto y dirigidos hacia áreas específicas del vehículo.

**Workplace hazardous materials information systems (WHMIS)** Canadian equivalent to MSDS sheets.

**Sistemas de información acerca de los materiales peligrosos en el área de trabajo (SIMPAT o WHMIS)** Equivalente canadiense a las hojas de datos de la seguridad de un material.

**Worm gear** A type of gear whose teeth wrap around the shaft. The action of the gear is much like that of a threaded bolt or screw.

**Engranaje de tornillo sin fin** Un tipo de engranaje cuyos dientes se envuelven alrededor del vástago. El movimiento del engranaje es muy parecido a un perno enroscado o una tuerca.

**Wye connection** A type of stator winding in which one end of the individual windings are connected at a common point. The structure resembles the letter “Y.”

**Conexión Y** Un tipo de devanado estátor en el cual una extremidad de los devanados individuales se conectan en un punto común. La estructura parece la letra “Y.”



## A

ABS. *See* antilock brake systems (ABS)

accumulator, 27

AC generators

- See also* charging systems
- component testing, 296–299
- diodes (rectifier bridges), 297–298
- diode trio, 298
- rotors, 296
- stators, 297

current output testing, 275

diagnostic chart for, 309

diode pattern testing, 283–285

diode/stator test, 282

disassembly, 290–295

full field tests, 275–281

inspection of components, 296

noises, 269

reassembly, 299

removal and replacement

- belt tension adjustment, 286–290

actuator tests, 368–370, 371–372, 489, 589, 607

- scan tool, 369–370

activation test, 370

AC voltage, 119, 283, 299

air bag module, 25

air bag system diagnostic module (ASDM), 648

air bag systems

- cleanup procedure after deployment, 651
- component replacement, 651–654
  - clockspring replacement, 652–654
  - module replacement, 651–652
- defined, 25
- diagnostic charts for, 671
- inspecting, after accident, 651
- retrieving fault codes, 645–646
- safety and services warnings, 644–645
- safety precautions with, 25–26
- system check of, 644
- system testing, 648–649

air gap, 410

air tools. *See* pneumatic tools, safety issues with

alarms. *See* antitheft systems

alcohol use, 3

alternating current (AC) voltage, 50, 58–59, 119

aluminum wire repairs, 146

ammeters, 41, 42, 51–52

ampere, 41–42

amplifier test, 493

analog gauges, 539

analog meters, 45

analog ohmmeters, 50

analog signals, 120, 122

antennas, 615–617

antilock brake systems (ABS), 26–27

antitheft systems, 594–600

- alarm sounds for no reason, 594
- circuit schematic of, 595
- controller test, 594–596
- diagnostic charts for, 640
- relay tests, 596
- self-diagnostic tests, 594, 599–600

appearance, personal safety and, 2

apprentices, 70

armature ground test, 252

armature short test, 252

asbestos, 22

- exposure, 22

ASDM. *See* air bag system diagnostic module (ASDM)

ASE certification, 72–74

audio entertainment systems, 615–617

automatic door lock systems, 591–593

automatic headlight systems, 492–506

- amplifier test, 493
- photocell replacement, 494–4952
- photocell test, 492–493
- resistance assembly test, 496
- SmartBeam diagnostics, 496–4503

automatic seat belt systems, 643–644

- circuit schematic of, 643
- drive motor assembly replacement, 644

automatic suspension systems, 201, 355

automatic wiper system, 577–579

automotive bulbs, 312

Automotive Service Excellence (ASE)

- certification, 72–74

average responding meters, 50

## B

back injuries, 6–7

backprobe, 48

back-up lights, 354

batteries, 185–214

- See also* charging systems
- battery drain test, 200–202
- battery inspection, 187–189
- charging the battery, 189–191, 679
- computerized load-testing equipment, 200
- diagnostic charts for, 225–227
- general precautions, 186–187
- high-voltage, 677–679
- introduction to, 185–186
- jumping the battery, 206–207
- load testing, 200

- maintaining and restoring memory functions, 191
- memory function maintenance, 191
- memory keepers, 66
- recycling, 213
- removal and cleaning, 202–206
- safety precautions with, 23–24
- selection of, 199
- test series, 191–200
  - batter terminal test, 192
  - battery leakage test, 193
  - capacity test, 197–199
  - conductance testing, 200
  - open circuit voltage test, 196–197
  - state of charge test, 193–195
  - three-minute charge test, 199
- BAT terminal, 24, 242, 244, 269
- battery acid, 186
- battery backups, 66
- battery ECU, 208–209, 677–678
- battery leakage test, 193
- battery load testers, 200
- battery stickers, 187
- battery terminal test, 192
- battery test equipment, 186
- BCM. *See* body control module (BCM)
- B-codes, 448
- bearings, faulty, 269
- belt tension sensors (BTs), 656, 658
- bimetallic gauges, 539
- bipolar transistors, testing, 116–117
- blade fuses, 104
- blower motor service, 581–583
  - constantly operating fans, 583
  - ground side switches, 581
  - insulated switches, 581
  - resistor block, 581
- body computer system. *See* body control module (BCM)
- body control module (BCM), 355–375
  - computer system functions, 355–357
  - computer voltage supply and ground circuits, 358–363
  - concealed headlight system and, 487–491
  - entering diagnostics, 365–368
  - flashing the, 373–374
  - of instrument panel, 529
  - introduction to, 355–357
  - service precautions, 357
  - testing actuators, 368–369
  - trouble codes, 364, 366
  - visual inspection, 365
- boots, 2
- brake lights, 330–334
- brake systems. *See* antilock brake systems (ABS)
- breakout boxes, 359, 407, 447
- brighter-than-normal lights, 321
- brush assembly checks, 251, 252
- BTs (belt tension sensors), 656–658

- bus bar lead repair, 585
- bus systems
  - CAN bus diagnostics, 457–460
  - class A bus system diagnostics, 452–454
  - communication fault codes, 447–448
  - enhanced scan tool diagnostics, 462–463
  - failures, 448
  - ISO 9141–2 bus system diagnostics, 448–450
  - ISO-K bus system diagnostics, 450–451
  - J1850 bus system diagnostics, 454–456
  - LIN bus diagnostics, 460–462

## C

- cable connections, for jump starts, 207, 256
- Cadillac BCM trouble codes, 366
- camera calibration procedure, 498–503
- capacitance discharge sensor, 403
- capacitors, 362
- capacity test, 197–198
- captured signals, 58
- carbon monoxide, 13–14
- cartridge fuses, 104
- Caustic chemicals, 4
- CD systems, 616
- ceramic fuses, 104
- certification, ASE, 72–74
- charge assist. *See* jump assist
- charge rate, 190
- charging systems, 267–310
  - AC generators
    - component testing, 296–299
    - disassembly, 290–294
    - noises, 269
    - reassembly, 299
    - removal and replacement, 286–290
  - current output testing, 275, 276
  - diagnostic charts, 308–310
  - diode pattern testing, 283–285
  - diode/stator test, 282
  - field current draw test, 274–275
  - full field tests, 275–277
  - introduction to, 267–269
  - precautions, 269
  - regulator test, 282
  - requirement test, 286
  - safety, 24–25
  - troubleshooting, 270–272
  - voltage drop testing, 272–273
  - voltage output testing, 270–272
- charging the battery, 189–191, 679–680
- chokes, 362
- Chrysler Collision Detection (CCD)
  - multiplexing system, 452–454
- cigarette smoking, 3, 25
- circuit breakers, 100–101
- circuit diagrams, reading, 154–158

circuit grounding, 48

circuit protection devices, 104–107

circuits, 96–97

- ground, 100–101, 240–241
- open, 96–97, 242–243
- prove-out, 546–547
- sensor return, 360–363

circuit test chart, 51

circuit testing

- with ammeter, 51–52
- for defects, 96–97
- ground circuit tests, 240–241
- insulated circuit resistance test, 240
- for opens, 96–97, 242–243
- for shorts, 97–99
- for short to ground, 100–101
- solenoid circuit resistance testing, 242

CKP. *See* crankshaft position sensor (CKP)

class A bus system diagnostics, 452–454

clockspring replacement, 652–654

clothing, personal safety and, 2

Code of Federal Regulations, 21

cold soak, 396

color codes, 154

combustible materials, storage of, 16

communication, with customers, 70

commutator tests, 252

compensation, 70

composite headlights

- aiming, 317–319
- replacement, 312–317

compressed air, safety issues, 8

computer-controlled lighting systems, 487–513

- automatic headlight system diagnosis, 491–507
- concealed headlight diagnosis, 487–491
- daytime running lamps, 505–507
- fiber optic diagnosis, 511
- headlight systems, 489–491
- illuminated entry lights, 507–510
- introduction to, 487

computer-controlled wiper systems, 574

- automatic system, 577–579
- hi/low control circuit high, 577
- hi/low control circuit low, 576–577
- on/off control circuit high, 576
- on/off control circuit low, 576
- park switch input circuit high, 575–576
- park switch input circuit low, 574–575

computer-driven instrumentation systems.

*See* instrument panels

computerized load-testing equipment, 200

computer services, for service information, 66

computer systems. *See* body control module (BCM)

concealed headlights, 322, 487–491

conductance testing, 200

conductors of electricity, 2, 24

connector terminals

- repairing, 149–153
- hard-shell connectors, 150–151
- metri-pack connectors, 153
- molded connectors, 150
- weather-pack connectors, 151–152

continuity tester, 44

control assembly. *See* electronic climate control panel (ECC)

Controller Area Network (CAN) bus systems, 457–460

controller test, 594–596

converters, 680–681

copper wire repairs, 140–146

courtesy lights, 335–336, 339

crankshaft position sensor (CKP), 539

crimping, 140–142

crocus cloth, 252

cruise control systems, 599–610

- component replacement, 609–610
- servo assembly, 609–611
- switch, 609

component testing, 607–609

- dump valves, 609
- servo assembly, 607–609
- speed sensors, 609

continuously changing speeds diagnosis, 606, 607

DaimlerChrysler, 604

- type 1, 604
- type 2, 604–605
- type 4, 604

diagnosing without trouble codes, 605–606

- no operation, 606
- simulated road test, 605–606

diagnostic charts for, 688

Ford, 602–603

General Motors, 599–602

- type 1, 599–600
- type 3, 600
- type 4, 600–602

intermittent operation diagnosis, 607

no operation diagnosis, 606

self-diagnostics, 599–602

speed control electrical schematic, 608

curb height, 317–318

current, 95

current draw tests, 237–238

current output testing, 275

customer relations, 71

cycles, 53, 54, 59, 119

## D

DaimlerChrysler

- AC generators, 296
- cruise control systems, 604
- electromechanical clusters (MICs), 533–534

Darlington transistors, 116

D'Arsonval movement, 45–46

- dash-mounted switches, 323–325, 574
- data buses. *See* bus systems
- data link connectors (DLC), 447
- daytime running lamps, 505–507
- DC/DC converter, 681
- DC voltage, 53, 58–59
- defogger diagnosis and repair, 584
- Delco Remy starter, 247–249
- demonstration mode, 498
- diagnostic charts
  - AC generators, 309
  - batteries, 226–227
  - burned fusible links, 184
  - burned or defective connectors, insulation, or conductors, 184
  - charging systems, 308–309
  - diodes, 309
  - electrical accessories, 633–642
  - electrical opens, 137
  - headlights, 350–351, 523
  - high-resistance problems, 137
  - hybrid electric vehicle (HEV) systems, 688
  - instrument panels, 558–559
  - lighting systems, 350–354, 523–524
  - multiplexing systems, 486
  - sensor diagnostic routines, 441–445
  - shorts, 137
  - starting systems, 264–265
  - voltage regulation, 309
- diagnostics
  - See also* troubleshooting
  - approach to, 74
  - cause-and-effect approach to, 149
  - importance of, 74
- diagnostic tools. *See* test equipment
- diagnostic trees, 68
- diagnostic trouble codes (DTCs), 63, 364–365
- diesel fuel, 16–17
- digital instrument panel cluster display, 647
- digital multimeters (DMMs), 46
- digital signals, 120–122
- digital storage oscilloscopes (DSOs), 58, 117–122
  - screen, 118–119
  - selecting voltage and time base, 119
  - trigger and trigger slope, 119–120
  - types of voltage signals, 120–121
  - user-friendly, 121
- digital volt/ohmmeters (DVOMs), 46
  - additional functions of, 53–54
  - reading, 54–55
- dim lights, 321–322
- dimmer/brighter-than-normal lights, diagnostics, 321
- dimmer switches, testing and replacement of, 326–329
- diode pattern testing, 283–285
- diodes
  - diagnostic chart for, 309
  - testing, 114–115, 297–298
- diode/stator test, 282–285
- DLC. *See* data link connectors (DLC)
- door locks, 591
  - automatic, 591–593
  - remote keyless entry systems, 593
- drain test, 200–202
- dress, personal safety and, 2
- drive belts, 268–269
  - loose, 269
- drug use, 3
- DSOs. *See* digital storage oscilloscopes (DSOs)
- DTCs. *See* diagnostic trouble codes (DTCs)
- dual ramping, 394
- dual range. *See* dual ramping
- dual resolution. *See* dual ramping
- dump valves, 609
- duty cycle, 53, 122, 369
- DVOMs. *See* digital volt/ohmmeters (DVOMs)

## E

- eddy currents, 534
- EEPROM chips, 373
- EIC. *See* electronic instrument cluster (EIC)
- electrical accessories, 561–618
  - antitheft systems, 594–596
  - audio entertainment systems, 615–617
  - blower motor service, 581–583
  - computer-controlled, 574–577
  - diagnostic charts for, 633–642
  - electric defoggers, 584–586
  - heated windshields, 612–615
  - horn diagnosis, 562–566
    - horn sounds continuous sound, 565
    - poor sound quality, 565
    - systems with relay, 562–564
    - systems without relay, 564–565
- immobilizer systems, 596–599
- introduction to, 561–562
- memory seats, 589–591
- power door locks, 398, 591
- power seats, 589
- power windows, 587–589
- remote keyless entry systems, 593
- sunroofs, 611–612
- video entertainment systems, 615–617
- windshield washer system service, 579–581
- wiper system service, 566–574
  - dash-mounted switch, removal and installation, 574
  - faulty park switch, 569–571
  - intermittent wiper system diagnosis, 571
  - no operation in one speed only, 567
  - no wiper operation, 568–569
  - slower than normal wiper speeds, 569
  - steering column-mounted switch, removal and installation 574
  - wiper motor removal and installation, 572–573

- electrical components
  - testing and replacing, 108–113
    - relays, 108–112
    - stepped resistors, 112
    - switches, 108–110
    - variable resistors, 112–113
- electrical diagram/schematics, 139
  - reading, 154–158
- electrical disturbances, 57
- electrical noise, 53, 57
- electrical opens. *See* open circuits
- electrical requirement, testing for, 286
- electrical system safety, 23–27
  - air bags, 25–26
  - antilock brake systems (ABS), 26–27
  - batteries, 23–24, 25
  - charging system, 24–25
  - starting system service, 24
- electrical systems technician, working as a, 70–75
  - work order completion, 72
- electrical test equipment. *See* test equipment
- electrical troubleshooting and service
  - basic, 95–122
  - introduction to, 95
  - process of, 139–140
  - test equipment for, 43–66
  - testing and replacing electrical components, 108–113
  - testing circuit protection devices, 104–107
  - testing diodes, 114–115
  - testing for circuit defects, 96–101
  - testing for voltage drop, 101–103
  - testing transistors, 116–117
  - using DSO, 117–122
- electric cooling fans, safety and, 6, 14
- electric current, 41
- electric defogger diagnosis and service, 584–586
  - bus bar lead repair, 585
  - grid wire repair, 585
- electricity, conductors of, 2, 43
- electromagnetic gauges, 539
- electromagnetic interference (EMI), 358, 361
- electromechanical clusters (MICs), self-test, 533
- electromotive force (EMF), 41
- electronic climate control panel (ECC), 366, 529, 599, 647
- electronic clusters, self-test, 534
- electronic cruise control systems. *See* cruise control systems
- electronic gauges, 543–544
- electronic instrument cluster (EIC)
  - diagnosis of, 529–531
  - function diagnostic mode, 529–530
  - imports, 531–533
  - prove-out display, 529
  - special test mode, 531
- electronic service precautions, 357–358
- electronic sunroofs, 611–612
- electrostatic discharge (ESD), 357–358
  - straps, 357
- employer-employee relations, 70–71
- entertainment systems, 615–617
- entry lights, 507–510
- environmental data, 392
- Environmental Protection Agency (EPA), 20
- equipment safety, 7–8
- eye injuries, 4
- eye protection, 3–4
- eyewash fountains, 4

**F**

- face shields, 4
- fail soft action, 357
- false wipes. *See* automatic wiper system
- fan motor service, 581–583
- fast charging, 190
- fault codes, 364, 447–448, 645–648
  - See also* trouble codes
  - Cadillac BCM trouble code, 366–368
- feedback, 97, 338
- fiber optic diagnosis, 511
- field coil testing, 251
- field current draw test, 274–275
- fire blanket, 17
- fire extinguishers
  - types, 14
  - use of, 17
- fire hazards, 14–18
- first-aid kits, 4
- flammable fumes, 15
- flash a computer, 373–374
- flash code, 364
  - retrieval, 646–648
- flashers, 334
- flat rate system, 70
- floor jacks, safe use of, 9–12
- floor-mounted switches, 329
- floor stands, 9–12
- footwear, 2
- Ford
  - AC generators, 290–295, 296–299
  - air bag flash codes, 647–648
  - electronic clusters, 534
  - integrated vehicle speed control (IVSC) systems, 602–603
- free speed test, 244–245
- free spin test, 244, 256
- freeze frame, 392
  - data, 676
- frequency, 53, 59, 121–122
  - signal, 54
- fuel gauges, 542–543
- fuel level senders, 535, 545
- full fielding, 275
  - test, 275–282

functional test, of AHS (automatic headlight systems), 492  
fuses, 104–108, 149  
    blown, 335, 488  
    determining current flows through, 202  
fusible links, 104–107, 148–149

## G

gasoline  
    containers, 16  
    as fire hazard, 14–16  
gauges  
    *See also* instrument panels  
    analog, 539  
    bimetallic, 539  
    defined, 539  
    diagnosis of conventional, 539–543  
    electromagnetic, 539  
    electronic, 543–544  
    failure of multiple, 541–543  
    failure of single, 540–541  
    fuel, 542–543  
    Gauss, 100–101  
    sending units, 544  
Gauss gauge, 100–101  
gear reduction starters, 249–250  
gel cell batteries, recharging, 191  
General Motors (GM)  
    AC generators, 275, 277  
    BCMs, 529  
    cruise control systems, 599–611  
    flash code retrieval, 646–647  
    heated windshield system, 613  
generator drive belts, 268–269  
generators, 24–25  
    *See also* AC generators; charging systems  
glitches, 57–58  
gloves, 4–5  
grids, 584  
grid wire repair, 585–586  
ground circuits, 240–242, 358–362  
ground straps, 154  
ground wires, 50

## H

hair, long, 2  
Hall-effect sensors, 416–417, 439  
hand protection, 4–5  
hand tools, safety issues, 7  
hard codes, 364  
hard-shell connectors, 150–151  
Hazard Communication Standard, 18  
hazard lights, 354  
hazardous materials, 18–23  
hazardous waste, 20–21  
headlight aiming pads, 318, 319  
headlights, 312–322

    aiming, 317–321  
        composite, 319–321  
        sealed-beam, 318–319  
    automatic headlight system diagnosis, 492–503  
    concealed, 322–323, 487–489  
    daytime running lamps, 505–507  
    diagnostic charts for, 350–351, 523–524  
    dimmer- or brighter-than normal, 321–322  
    dimmer switch testing and replacement, 326–329  
    HID lamp and ballast service, 315–317  
    replacement, 312–317  
    switch testing and replacement, 312–317  
    testing computer-controlled, 489–491  
    types of, 312  
heated windshields, 612–615, 641  
heat shrink tubes, 142  
heavy objects, lifting, 6  
hertz, 53  
HEV inverter/converter, 299–300  
HID lamp and ballast service, 315–317  
high beam camera calibration, 500–502  
High-efficiency particulate-arresting (HEPA), 22  
    vacuum cleaner, 22  
high-resistance problems, 95, 101–102, 137  
high-voltage batteries, 679–680  
high-voltage electronic control unit (HV ECU), 676–677  
high-voltage service plugs, 675–676  
high-voltage systems. *See* hybrid electric vehicle (HEV) systems  
history data information, 676  
hoist pads, 12–13  
hoists, safe use of, 12–13  
Honda air bag systems, 648–649  
horn diagnosis, 562–566  
    continuous sound, 565–566  
    diagnostic charts, 634  
    no horn operation, 562–565  
    poor sound quality, 565  
hotline services, 70  
HV battery service, 207–210  
    high-voltage charging, 210–22  
hybrid electric vehicle (HEV) systems  
    diagnostic charts for, 688  
    high-voltage battery service, 677–680  
    high-voltage service plugs, 30–31, 675–676  
    insulated glove integrity test, 30  
    insulation tester, 55–56  
    introduction to, 673  
    inverter/converter assembly, 680–681  
    safety precautions with, 673–675  
    self-diagnosis capabilities, 676–677  
    system main relay (SMR), 682  
hydrometer  
    battery, 188  
    testing batteries with, 193–194  
hydrostatic lock, 234  
Hypalon, 148



- I**
- IAR. *See* integral alternator/regulator (IAR) system
  - illuminated entry actuator, 507
  - illuminated entry lights, 355, 507–510
  - immobilizer systems, 596–599, 641
  - impedance multimeters, 357
  - information codes, 676–677
  - injury prevention. *See* safety
  - instrument cluster lights, 351, 352
  - instrument panels
    - BCM diagnostics, 529
    - conventional gauge diagnosis, 539–543
    - diagnostic charts, 558–559
    - electronic gauge diagnosis, 543–544
    - gauge sending units, 544
    - introduction to, 527–528
    - removal, 528
    - self-diagnostics, 529–534
    - speedometers, 534–539
    - tachometers, 539–540
    - trip computers, 547
    - warning lamps, 544–547
  - instrument voltage regulator (IVR), 539, 556–557
  - insulated circuit resistance test, 240
  - insulating gloves, 675
  - integral alternator/regulator (IAR) system, 274–275
    - full field testing, 278–279
  - integrated vehicle speed control (IVSC) systems, 602–603
  - interior lights, 335–338
    - courtesy lights, 335–337
    - instrument cluster and panel lights, 338
  - intermittent codes, 364
  - intermittent wiper system diagnosis, 571–572
  - inverter, 680
  - inverter/converter assembly, 680–681
  - ISO 9141-2 bus system diagnostics, 448–450
  - ISO-K bus system diagnostics, 450–451
  - IVR. *See* instrument voltage regulator (IVR)
- J**
- jack stands, 9–10
  - J1962 breakout box (BOB), 447
  - J1850 bus system diagnostics, 454–456
  - jewelry, 2
  - Job sheets
    - active speed sensor circuit diagnosis, 437–438
    - air bag system safety, 661–662
    - antitheft system operation testing, 629–630
    - automatic headlight system, 515–516
    - automatic high-beam systems, 521–522
    - battery cleaning and inspection, 217–218
    - battery conductance tester usage, 223–224
    - battery removing, cleaning, and installation, 219–220
    - battery service and diagnosis
      - hybrid vehicle, 226–227
      - BCM.flashing, 379–381, 387–388
      - BCM-controlled headlight system, 517–519
      - CAN bus system diagnosis, 479–482
      - capacity testing, battery, 221–222
      - charging system circuit testing, 307–310
      - circuit protection and PTCs operation, 425–426
      - circuit protection devices testing, 129–130
      - clockspring replacement and centering, 667–668
      - component locator, usage, 173–174
      - copper wires soldering, 183–184
      - current draw of starter motor, 261–262
      - diode testing, 133–134
      - DMM testing, magnetic induction sensor, 431–432
      - drive belts inspection, 303–304
      - driver squib circuit open fault diagnosis in air bag system, 663–665
      - DSO usage on sensors and switches, 135–137
      - electronic cruise control system testing, 627–628
      - electronic instrument cluster, 555–556
      - engine coolant temperature sensor testing, 421–423
      - fire hazard inspection, 37
      - fuel gauge checking, 551–552
      - hall-effect sensors, 439–440
      - headlight aiming equipment, 349–350
      - headlight switch, checking, 347–348
      - hybrid safety, 39–40, 685–688
      - immobilizer key programming, 631–633
      - ISO 9141-2 Bus system diagnosis, 467–469
      - ISO-K Bus system diagnosis, 471–472
      - J1850 Bus system diagnosis, 473–477
      - lab scope testing, magnetic induction sensor, 433–434
      - lighting systems diagnosis, 345–346
      - LIN Bus system diagnosis, 483–485
      - magneto-resistive sensor tester building of, 435–436
      - meter symbol interpretation, 85
      - OCS (Occupant Classification System) validation procedure, 669–670
      - ohmmeter, 91–93
      - Ohm's law calculation, 79–83
      - oil pressure warning light circuit, 553–554
      - open circuit testing, 125
      - output testing, charging system, 305–306
      - potentiometer testing, 429–430
      - pressure switch analysis, 427–428
      - rear window defogger testing, 625–626
      - scan tool usage, 383–385
      - shop safety survey, 35–36
      - short to ground testing, 127–128
      - starting system circuit testing, 263–265
      - switches testing, 131–132
      - test light usage, 87
      - voltmeter usage, 89–90
      - windshield, 621–624
        - wiring diagram, 171–172, 177–182
    - jump assist, 214
    - jumper wires, 43, 96, 108
    - jump starts, 206–207

## K

keyless entry systems, 589, 641  
knock sensor, 406  
KOEO (key on engine off), 602, 603  
KOER (key on engine running), 602, 603

## L

lab scopes, 56–62, 236–237  
    testing actuators with, 371–373  
lamp sequence check, 589–590  
LEDs, testing, 115  
Lifting  
    heavy objects, 6  
    vehicles, 8–13  
lift points, 10–12  
lighting circuits, 311–342  
    brake lights, 330–333  
    dimmer switch testing and replacement, 326–329  
    flashers, 334  
    headlights, 312–322  
        aiming, 317–321  
        concealed, 322–323  
        dimmer- or brighter-than normal, 321–322  
        replacement, 312–317  
        switch testing and replacement, 323–326  
    interior lights, 335–338  
    introduction to, 311–312  
    taillight assemblies, 329–334  
    turn signals, 330–333  
lighting systems  
    complexity, 338–341  
    computer-controlled, 489–491  
        automatic headlight system diagnosis, 492–503  
        concealed headlight diagnosis, 487–489  
        daytime running lamps, 505–507  
        headlight systems, 489–491  
        illuminated entry lights, 507–510  
        introduction to, 487  
    diagnostic charts for, 350–354, 523–524  
live air bag modules, 644  
live module, 644  
load testers/testing, 197, 270  
local interconnect network (LIN) bus systems, 460–462  
locking tangs, 151, 152  
logic probes, 44–45  
long hair, 2

## M

magnetic induction sensors, 410  
magnetic pickup speed sensors, 537–538  
magnetoresistive (MR) sensors, 410  
material safety data sheets (MSDS), 19–20  
maxi-fuses, 104  
memory functions, maintaining and restoring, 191  
memory keepers, 66  
    *See also* battery backups

memory seats, 562, 589–591, 639  
metri-pack connectors, repairing, 153  
mileage readings, 536  
molded connectors, 149, 150  
MSDS. *See* material safety data sheets (MSDS)  
multifunction switches, 326–327  
multimeters, 45–56  
    additional functions of, 53–54  
    ammeters, 51–52  
    analog meters, 45–46  
    digital, 46–47  
    ohmmeters, 50–51  
    reading, 54–55  
    trigger level of, 53  
    voltmeters, 47–50  
multiplexing systems, 447–463  
    CAN bus diagnostics, 457–460  
    class A bus system diagnostics, 452–454  
    communication fault codes, 447–448  
    diagnostic charts for, 486  
    enhanced scan tool diagnostics, 462–463  
    introduction to, 447  
    ISO 9141-2 bus system diagnostics, 448–450  
    ISO-K bus system diagnostics, 450–451  
    J1850 bus system diagnostics, 454–456  
    LIN bus diagnostics, 460–462  
multiplying coil, 274

## N

Negative temperature coefficient (NTC), 394  
no-crank problems, 234, 242–244, 234, 242  
noises, 53, 53, 57  
    from AC generators, 269  
    circuit, 362  
no-load test, 244  
normally open (NO) switches, 108

## O

occupant classification systems (OCSs), 655–658  
Occupational Safety and Health Act, 20  
Occupational Safety and Health Administration (OSHA), 18  
occupational safety glasses, 3  
OCS service kits, 655  
OCS validation test, 656  
odometer mileage labels, 532  
odometers, 536–538  
ohm, 41  
ohmmeters, 41, 50–51, 97  
    testing brush holders with, 252–253  
    testing bus system failures, 452–454  
    testing diodes with, 114–115  
    testing field coils with, 251  
    testing relays with, 111–112  
    testing stepped resistors with, 112  
    testing switches with, 108  
    testing variable resistors with, 112–113

- oil disposal, 22
- One-hand rule, 28
- open circuits, 95
  - diagnostic chart for, 137
  - testing for, 96–97
- open circuit test, 242–244
- open circuit voltage test, 196–197
- optical refractometer, 195
- optical speed sensors, 538–539
- optics test, 502
- oscilloscopes, 56–62
  - controls, 60–62
  - digital storage oscilloscope (DSOs), 117–122
  - diode pattern testing with, 283–285
  - waveforms, 58–60
- overloads, 104
- overrunning clutch inspection, 253–254

## P

- panel lights, 338
- parasitic drain, 200
- parking lamps, 350, 507
- park switch, 569–371
- passive restraint systems, 643–658
  - air bag systems, 644–645
  - automatic seat belt service, 643–644
  - diagnostic charts for, 671
  - introduction to, 643
  - occupant classification systems (OCSs), 655–658
- pay systems, 70
- peak, 119
- peak-to-peak voltage, 119
- personal safety, 2–7
  - alcohol and drugs and, 3
  - dress and appearance and, 2
  - with electric cooling fans, 6
  - eye protection, 3–4
  - eyewash fountains, 4
  - first-aid kits, 4
  - hand protection, 4–5
  - lifting and, 6
  - with rotating equipment, 6
  - smoking and, 3
  - when working with batteries, 186–187, 189
- photocell resistance assembly, 496
- photocells, 492
  - replacement, 493
  - testing, 493
- piezoelectric sensors, 406
- piezoelectric transducer, 406
- piezoresistive construction, 400
- piezoresistive sensor, 544
- pinpoint tests, 603
- pneumatic tools, safety issues with, 7
- polymer, 396
- positive temperature coefficient (PTC), 394, 396

- potentiometers, 113, 407–410
- power door lock diagnosis, 591, 638
- power seat diagnosis, 589, 636–637
- power tools
  - inspection of, 8
  - safety issues, 7
- power window diagnosis, 587–588, 636
- printed circuit board, removal, 528
- PROM replacement, 358
- protection devices. *See* circuit protection devices
- protective gear
  - eye protection, 3–4
  - hand protection, 4–5, 675
- prove-out circuits, 546
- prove-out displays, 529
- pull to seat connectors, 153
- pulse width, 53, 120, 121
- pulse width modulation (PWM), 122
- push to seat connectors, 153

## Q

- quartz swing needle, 536–537
- quick testing, 235–236

## R

- radio frequency interference (RFI), 358, 616
- radio systems, 615–617
- rags, storage of dirty, 15, 17
- rear window defogger, 355, 584–585
- Rechargeable Battery Recycling Corporation (RBRC), 213
- recharging. *See* charging the battery
- rectifier bridge, testing, 298
- refractometer, 195
- regulator test, 282
- relative compression testing, 238–239
- relays
  - system main relay (SMR), 682
  - testing, 108–112, 596, 597–598
- remote keyless entry systems, 593
- resistance, 95
  - See also* voltage drop
  - infinite, 50
  - low, 51
- resistance assembly test, 496
- resistance problems, 95
  - sensor return circuits and, 360–363
  - testing for, 112–113
- resistive shorts, 544
- resistor block, 581
- Resource Conservation and Recovery Act (RCRA), 21
- RF sniffer tool, 617
- rheostats, 112–113
- right-to-know laws, 18–20
- root mean square (RMS), 119

root mean square (RMS) meters, 50  
rotating equipment, safety and, 6  
rotors, testing, 296–297

## S

safety, 1–31  
  electrical systems, 23–27  
  fire hazards and prevention, 14–18  
  with hazardous materials, 18–23  
  with hybrid systems, 673–675  
  introduction to, 1  
  lifting vehicles, 8–13  
  personal, 2–7  
  running vehicles in shop, 13–14  
  tool and equipment, 7–8  
safety goggles, 4  
safety stands, safe use of, 9–12  
satellite radio systems, 617  
scan tester diagnostics, 365–368, 594  
scan tools, 62–65  
  communication between bus system and, 448–450  
  for DTC retrieval, 645–646  
  enhanced diagnostics, 462–463  
  flashing the BCM with, 373–374  
  sensor testing with, 373  
  vehicle module scans, 448  
scopes. *See* oscilloscopes  
sealed-beam headlights  
  aiming, 312–314  
  replacement, 313–314  
seat belt systems. *See* automatic seat belt systems  
self-diagnostic tests  
  for anti-theft systems, 594  
  for BCM ATC-controlled systems, 529  
  for cruise control systems, 599–611  
  of hybrid systems, 676–677  
self-powered continuity tester, 44  
self-test input (STI) terminal, 603  
sending units, gauge, 544  
sensor diagnostic routines  
  introduction, 391–392  
  intermittent faults, 392–393  
  magnetoresistive, 413–415  
    alternate, 415  
  position and motion detection sensors, 407–  
    magnetic induction, 410–413  
    potentiometer testing, 407–410  
pressure sensors  
  capacitance discharge, 403  
  lab scope testing, 405  
  piezoelectric transducers, 406–407  
  switch, 397–400  
  wheatstone bridge and DMM testing, 400–402  
temperature sensors and circuits  
  PTC circuit protection devices, 396–397  
  thermistor circuits, 394–396  
  sensor dropout, 410  
  sensor return circuits, 360–363  
  sensors, testing, 394–397  
  service history tracking, 70  
  service information/manuals, 66–70  
  servo assembly, 607–609  
  servomotor, 603–604  
shoes, 2  
short circuits, 95  
  testing for, 97–99  
short to ground, 100–101  
  checking for, 100  
Silicone/GXL, 148  
simulated road tests, for cruise control systems, 605  
sine waves, 50, 58–59  
sinusoidal waves, 58  
slow charging, 189  
slow cranking, 230, 233  
SmartBeam diagnostics, 496–503  
  camera calibration test and adjustment, 498–502  
  demonstration mode, 498  
smoking, 3, 15  
SMR. *See* system main relay (SMR)  
soldering, 142–146  
solderless connectors, crimping, 140–142  
solenoid circuit resistance testing, 242  
solvents, 17  
  disposal of, 22  
spade fuses, 104  
speaker problems, 616  
special tools  
  memory keepers, 66  
  service information/manuals, 66–70  
  static straps, 65–66  
  test equipment, 43–65  
specifications, 67  
specific gravity, measuring, 194  
speedometer readings, 532  
speedometers, 534  
  conventional, 534–536  
  diagnosis and repair, 534–539  
  electronic, 536–539  
speed sensors, 410–415, 532–533  
  ABS wheel, 410, 433  
  magnetic pickup, 537–538  
  optical, 538–539  
  testing, 609  
splice clips, 142  
splices, 140, 142  
square waves, 59  
stabilize the battery, 196  
starter/charging system tester, 235  
starter motors  
  component tests, 249–254  
    armature ground test, 252  
    armature short test, 252

- brush inspection, 252–253
- commutator tests, 252
- field coil tests, 251
- overrunning clutch inspection, 253–254
  - disassembly, 247–249
  - reassembly, 254–256
  - removal, 245–247
- starter safety switches, 244
- starter systems, 229–256
  - components, 229–230
  - diagnostic charts for, 231–233, 264–265
  - introduction to, 229–230
  - precautions, 230
  - safety, 24
  - starter motor component tests, 249–254
  - starter motor disassembly, 247–249
  - starter motor removal, 245–247
  - starter reassembly, 254–256
  - testing, 235–245
    - current draw tests, 237–238
    - free speed test, 244–245
    - ground circuit test, 240–242
    - insulated circuit resistance test, 240
    - lab scope tests, 236–237
    - open circuit test, 242–244
    - quick tests, 235–236
    - relative compression tests, 238–239
    - solenoid circuit resistance test, 242
  - troubleshooting, 230–235
- starting/charging system testers, 267, 280
- state of charge (SOC), 676
- state of charge test, 193–195
- static charges, 65
- static electricity, 357, 529
- static straps, 65–66
- stators, testing, 282
- steering column module (SCM), 460
- steering column-mounted switches, 326, 329, 574
- stepped resistors, testing, 112
- stop lights. *See* brake lights
- sulfated battery, 199
- sulfation, 199
- sulfuric acid, 188, 202–203
- Sun Electrical Corporation VAT-40, 186
- sunroofs, 611–612, 639–640
- switches
  - cruise control system, 609
  - dash-mounted, 323–326, 574
  - dimmer, testing and replacement, 326–329
  - floor-mounted, 329
  - Hall-effect, 416–417
  - headlight, testing and replacement, 3223–326
  - multifunction, 326, 329–330
  - power window, 587–589
  - steering column-mounted, 326, 329, 574
  - testing, 108
  - turn signal, 327–329, 330–334

- wiper, 571–572, 574, 617
  - wiper park, 574–575
- switch operational logic chart, 644
- system main relay (SMR), 30, 682

## T

- tachometers, 539
- taillight assemblies, 329–334
- tap splice connector, 142
- Technical Service Bulletins (TSBs), 67
- temperature sensor, overriding, 612
- test equipment, 43–45
  - for batteries, 185–186
  - computerized load-testing equipment, 200
  - digital storage oscilloscope (DSOs), 117–122
  - J1962 breakout box (BOB), 447
  - jumper wires, 43
  - logic probes, 44–44
  - multimeters, 45–56
  - ohmmeters, 50–51
  - optical refractometer, 195–196
  - oscilloscopes, 56–62
  - potentiometers, 407–410
  - RF sniffer tool, 617
  - scan tools, 62–65, 369–371
  - self-powered continuity tester, 44
  - test lights, 44
  - voltmeters, 47–50
- test lights, 44–45, 96
  - testing power windows with, 588
  - testing relays with, 108–112
  - testing for shorts with, 97–99
  - testing switches with, 108
- thermistors, 394–396, 544
- three-minute charge test, 199–200
- throttle position sensor (TPS), 120, 408
- tin, 585
- tinning, 142
- tool safety, 7–8
- Toyota, air bag flash codes, 648
- transistors, testing, 116–117
- trickle charging, 190
- trigger, 119
  - slope, 119–120
- trip computers, 547
- trouble codes, 139
  - for air bag systems, 645–648
  - BCM, 366–368
  - B-codes, 448
  - for cruise control systems, 599–605
  - for hybrid systems, 676
  - instrument panel, 529
  - U-codes, 448
- troubleshooting
  - See also* diagnostic charts; electrical accessories defined, 139
  - electrical problems, 42–43
  - process of, 139–140

turn signals, 330–334, 353  
turn signal switches, 327–334  
twisted/shield wire repairs, 146–148

## U

U-codes, 447

## V

vapors, gasoline, 14  
variable resistors, testing, 112–113  
VAT-40, 267  
vehicle identification number (VIN), 67, 367  
vehicle lift points, 10–11  
vehicle module scans, 448  
vehicle safety  
    on lifts and hoists, 8–13  
    while running in shop, 13–14  
vehicle speed sensors (VSSs), 533, 410–411  
ventilation systems, testing, 13  
video entertainment systems, 615–617  
VIN numbers, 67, 367  
volatile substances, 16  
voltage, 41, 95  
    AC, 50, 58–59, 119  
    DC, 58–59  
    peak-to-peak, 119  
    waveforms, 58–60  
voltage drop, 47–50, 106  
    measuring, 192, 240–242  
    testing, 101–103, 272–273  
        of headlight system, 321  
voltage output testing, 270–272  
voltage regulation, diagnostic chart for, 309  
voltage signals, types of, 120–122  
voltage supply, diagnosis of computer, 358–363  
voltmeters, 42, 43, 47–50, 106  
    *See also* oscilloscopes  
    testing batteries with, 192–193  
    testing diodes with, 114  
    testing relays with, 108–112  
    testing stepped resistors with, 112  
    testing switches with, 109  
    testing variable resistors with, 113  
    testing voltage drop with, 101–103  
volts, 41

## W

wages, 71  
warning lamps, 527–528, 544–547, 557  
    for air bag systems, 645–648  
waste disposal, 21–22  
    asbestos, 22  
    oil, 22  
    solvents, 22  
waveforms, 58–60, 120–122  
weather-pack connectors, repairing, 151–152  
wheatstone bridge, 400  
wheels, blocking, 10  
wheel speed sensors, 410, 411, 414–415  
whining noises, 269  
wiggle test, 58  
Williams-Steiger Act, 20  
window defogger, 584–585, 637  
windshields, heated, 612–615  
windshield washer system service, 579–581  
wiper system service, 566–574  
    diagnostic charts, 634–635  
    intermittent wiper system diagnosis, 571–572  
    no operation in one speed only, 567–568  
    no wiper operation, 568–569  
    slow speed, 569  
    wiper circuit, two-speed, 568  
    wiper motor removal and installation, 572–574  
    wiper switch removal and installation, 574  
    wiper system schematic, three-speed, 567  
    wiper will not park, 569–571  
wire repair, 140–148  
    aluminum, 146  
    copper, 140–142  
    twisted/shielded, 146–148  
wires, checking for shorts, 51, 52  
wiring diagrams, reading, 154–158  
work order, 72  
workplace hazardous materials information systems (WHMIS), 19  
workplace relationships, 70–71

## Z

Zener diodes  
    testing, 114–115