

# SECTION 6-1

## ENGINE GENERAL INFORMATION AND DIAGNOSIS (H25 ENGINE)

**WARNING:**

For vehicles equipped with Supplemental Restraint (Air Bag) System:

- Service on and around the air bag system components or wiring must be performed only by an authorized SUZUKI dealer. Refer to “Air Bag System Components and Wiring Location View” under “General Description” in air bag system section in order to confirm whether you are performing service on or near the air bag system components or wiring. Please observe all WARNINGS and “Service Precautions” under “On-Vehicle Service” in air bag system section before performing service on or around the air bag system components or wiring. Failure to follow WARNINGS could result in unintentional activation of the system or could render the system inoperative. Either of these two conditions may result in severe injury.
- Technical service work must be started at least 90 seconds after the ignition switch is turned to the “LOCK” position and the negative cable is disconnected from the battery. Otherwise, the system may be activated by reserve energy in the Sensing and Diagnostic Module (SDM).

**NOTE:**

Whether following systems (parts) are used in the particular vehicle or not depends on specifications. Be sure to bear this in mind when performing service work.

- Monitor connector
- CKP sensor
- MAP sensor
- EGR valve
- Heated oxygen sensor or CO adjusting resistor
- Three way catalytic converter, Warm-up three way catalytic converter

ENGINE GENERAL INFORMATION AND DIAGNOSIS (H25 ENGINE) .....	6-1-1
ENGINE MECHANICAL .....	6A2-1
ENGINE COOLING .....	6B-1
ENGINE FUEL .....	6C-1
ENGINE AND EMISSION CONTROL SYSTEM .....	6E2-1
ENGINE IGNITION SYSTEM .....	6F2-1
CRANKING SYSTEM .....	6G-1
CHARGING SYSTEM .....	6H-1
ENGINE EXHAUST .....	6K-1

## CONTENTS

GENERAL INFORMATION .....	6-1- 4	General Information on Engine Service ..	6-1- 5
Statement of Cleanliness and Care .....	6-1- 4	Precaution on Fuel System Service ...	6-1- 6

Fuel Pressure Relief Procedure	6-1- 7	DTC P0141 HO2S (Bank-1 Sensor-2) Heater Circuit Malfunction	6-1-71
Fuel Leakage Check Procedure	6-1- 8	DTC P0150 HO2S (Bank-2 Sensor-1) Circuit Malfunction	6-1-73
<b>ENGINE DIAGNOSIS</b>	6-1- 9	DTC P0153 HO2S (Bank-2 Sensor-1) Circuit Slow Response	6-1-75
General Description	6-1- 9	DTC P0154 (DTC No.26) HO2S (Bank-2 Sensor-1) No Activity Detected	6-1-76
On-Board Diagnostic System (Vehicle without Monitor Connector)	6-1- 9	DTC P0155 HO2S (Bank-2 Sensor-1) Heater Circuit Malfunction	6-1-78
On-Board Diagnostic System (Vehicle with Monitor Connector)	6-1-12	DTC P0156 HO2S (Bank-1 Sensor-2) Circuit Malfunction	6-1-80
Precaution in Diagnosing Trouble	6-1-14	DTC P0161 HO2S (Bank-2 Sensor-2) Heater Circuit Malfunction	6-1-82
Engine Diagnostic Flow Table	6-1-15	DTC P0171 Fuel System too Lean (Bank-1)	6-1-84
Malfunction Indicator Lamp (MIL) Check	6-1-20	DTC P0172 Fuel System too Rich (Bank-1)	6-1-84
Diagnostic Trouble Code (DTC) Check	6-1-20	DTC P0174 Fuel System too Lean (Bank-2)	6-1-86
Diagnostic Trouble Code (DTC) Clearance	6-1-21	DTC P0175 Fuel System too Rich (Bank-2)	6-1-86
Diagnostic Trouble Code (DTC) Table	6-1-22	DTC P0300 Random Misfire Detected	6-1-88
Fail-Safe Table	6-1-26	DTC P0301 Cylinder 1 Misfire Detected	6-1-88
Scan Tool Data	6-1-27	DTC P0302 Cylinder 2 Misfire Detected	6-1-88
Scan Tool Data Definitions	6-1-30	DTC P0303 Cylinder 3 Misfire Detected	6-1-88
Engine Diagnosis Table	6-1-33	DTC P0304 Cylinder 4 Misfire Detected	6-1-88
ECM (PCM) Substitution	6-1-38	DTC P0305 Cylinder 5 Misfire Detected	6-1-88
Inspection of ECM (PCM) and Its Circuits	6-1-38	DTC P0306 Cylinder 6 Misfire Detected	6-1-88
Voltage Check	6-1-38	DTC P0335 Crankshaft Position Sensor Circuit Malfunction	6-1-90
Resistance Check	6-1-44	DTC P0340 (DTC No.42) Camshaft Position Sensor Circuit Malfunction	6-1-92
Table A-1 Malfunction Indicator Lamp Circuit Check	6-1-46	DTC P0400 (DTC No.51) Exhaust Gas Recirculation Flow Malfunction	6-1-95
Table A-2 Malfunction Indicator Lamp Circuit Check	6-1-48	DTC P0420 Catalyst System (Bank-1) Efficiency Below Threshold	6-1-98
Table A-3 Malfunction Indicator Lamp Check	6-1-48	DTC P0430 Catalyst System (Bank-2) Efficiency Below Threshold	6-1-98
Table A-4 Malfunction Indicator Lamp Check	6-1-49	DTC P0443 EVAP Control System Purge Control Valve Circuit Malfunction	6-1-100
Table A-5 ECM (PCM) Power and Ground Circuit Check	6-1-50	DTC P0460 Fuel level sensor circuit high input	6-1-105
DTC P0100 (DTC No.33, 34) Mass Air Flow Sensor Circuit Malfunction	6-1-52	DTC P0500 (DTC No.24) Vehicle Speed Sensor Malfunction	6-1-107
DTC P0110 (DTC No.23, 25) Intake Air Temp. Circuit Malfunction	6-1-54	DTC P0505 Idle Air Control System Malfunction	6-1-110
DTC P0115 (DTC No.14, 15) Engine Coolant Temp. Circuit Malfunction	6-1-56	DTC P0601 Internal Control Module Memory Check Sum Error	6-1-113
DTC P0120 (DTC No.21, 22) Throttle Position Circuit Malfunction	6-1-58		
DTC P0121 Throttle Position Circuit Performance Problem	6-1-60		
DTC P0130 HO2S (Bank-1 Sensor-1) Circuit Malfunction	6-1-62		
DTC P0133 HO2S (Bank-1 Sensor-1) Circuit Slow Response	6-1-64		
DTC P0134 (DTC No.13) HO2S (Bank-1 Sensor-1) No Activity Detected	6-1-65		
DTC P0135 HO2S (Bank-1 Sensor-1) Heater Circuit Malfunction	6-1-67		
DTC P0136 HO2S (Bank-1 Sensor-2) Circuit Malfunction	6-1-69		

DTC P1408 Manifold Absolute Pressure Sensor Circuit Malfunction . .	6-1-114	Table B-1 Fuel Pump Circuit Check . .	6-1-121
DTC P1450 Barometric Pressure Sensor Circuit Malfunction . . . . .	6-1-116	Table B-2 Fuel Injector Circuit Check .	6-1-123
DTC P1451 Barometric Pressure Sensor Performance Problem . . . . .	6-1-116	Table B-3 Fuel Pressure Check . . . . .	6-1-125
DTC P1500 Engine Start Signal Circuit Malfunction . . . . .	6-1-118	Table B-4 A/C Signal Circuit Check (if equipped) . . . . .	6-1-127
DTC P1510 ECM Back-Up Power Supply Malfunction . . . . .	6-1-120	Table B-5 A/C Condenser Fan Motor Relay Control System Check (if equipped) . . . . .	6-1-129
		<b>SPECIAL TOOLS</b> . . . . .	6-1-131

## GENERAL INFORMATION

### STATEMENT OF CLEANLINESS AND CARE

An automobile engine is a combination of many machined, honed, polished and lapped surfaces with tolerances that are measured in the thousands of an millimeter (ten thousands of inch). Accordingly, when any internal engine parts are serviced, care and cleanliness are important. Throughout this section, it should be understood that proper cleaning and protection of machined surfaces and friction areas is part of the repair procedure. This is considered standard shop practice even if not specifically stated.

- A liberal coating of engine oil should be applied to friction areas during assembly to protect and lubricate the surface on initial operation.
- Whenever valve train components, pistons, piston rings, connecting rods, rod bearings and crankshaft journal bearings are removed for service, they should be retained in order. At the time of installation, they should be installed in the same locations and with the same mating surfaces as when removed.
- Battery cables should be disconnected before any major work is performed on the engine. Failure to disconnect cables may result in damage to wire harness or other electrical parts.

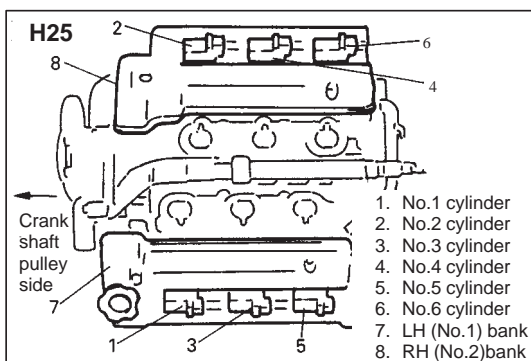

- Throughout this manual, the 6 cylinders of the engine are identified by numbers; No.1, No.2, No.3, No.4, No.5 and No.6 as counted from crankshaft pulley side to flywheel side.
- Figure at the left shows engine with intake manifold removed and viewed from the top.  
 LH (No.1) bank consists of No.1, No.3 and No.5 cylinders.  
 RH (No.2) bank consists of No.2, No.4 and No.6 cylinders.

## GENERAL INFORMATION ON ENGINE SERVICE

THE FOLLOWING INFORMATION ON ENGINE SERVICE SHOULD BE NOTED CAREFULLY, AS IT IS IMPORTANT IN PREVENTING DAMAGE, AND IN CONTRIBUTING TO RELIABLE ENGINE PERFORMANCE.

- When raising or supporting engine for any reason, do not use a jack under oil pan. Due to small clearance between oil pan and oil pump strainer, jacking against oil pan may cause it to be bent against strainer resulting in damaged oil pick-up unit.
- It should be kept in mind, while working on engine, that 12-volt electrical system is capable of violent and damaging short circuits.

When performing any work where electrical terminals could possibly be grounded, ground cable of the battery should be disconnected at battery.

- Any time the air cleaner, air cleaner outlet hose, throttle body, surge tank pipe, intake collector or intake manifold is removed, the intake opening should be covered. This will protect against accidental entrance of foreign material which could follow intake passage into cylinder and cause extensive damage when engine is started.

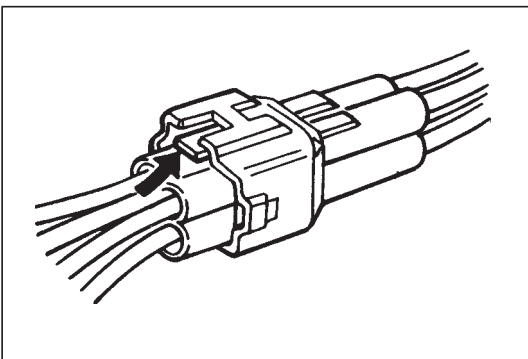

- When disconnecting couplers, don't pull wire harness but make sure to hold coupler itself. With lock type coupler, be sure to unlock before disconnection. Attempt to disconnect coupler without unlocking may result in damage to coupler. When connecting lock type coupler, insert it till clicking sound is heard and connect it securely.

With short pipe, fit hose as far as it reaches pipe joint as shown.

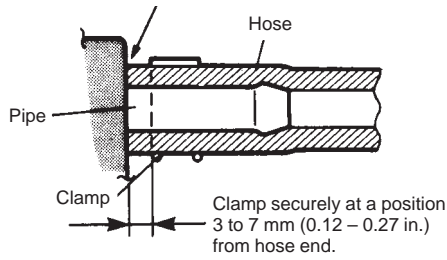

With following type pipe, fit hose as far as its peripheral projection as shown.

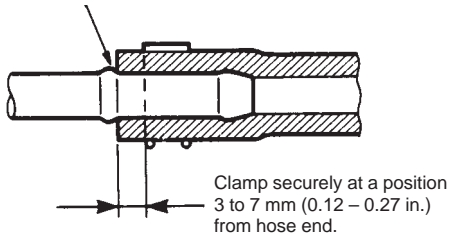

With bent pipe, fit hose as far as its bent part as shown or till pipe is about 20 to 30 mm (0.79 - 1.18 in.) into the hose.

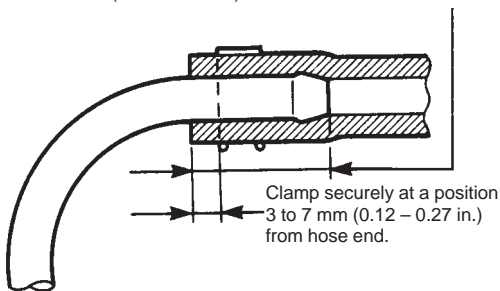

With straight pipe, fit hose till pipe is about 20 to 30 mm (0.79 - 1.18 in.) into the hose.

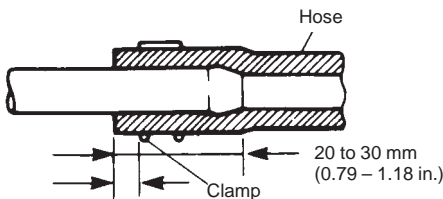

Clamp securely at a position 3 to 7 mm (0.12 - 0.27 in.) from hose end.

## PRECAUTION ON FUEL SYSTEM SERVICE

- Work must be done with no smoking, in a well-ventilated area and away from any open flames.
- As fuel feed line (between fuel pump and fuel pressure regulator) is still under high fuel pressure even after engine was stopped, loosening or disconnecting fuel feed line directly may cause dangerous spout of fuel to occur where loosened or disconnected. Before loosening or disconnecting fuel feed line, make sure to release fuel pressure according to "FUEL PRESSURE RELIEF PROCEDURE" in this section.

A small amount of fuel may be released after the fuel line is disconnected.

In order to reduce the chance of personal injury, cover the fitting to be disconnected with a shop cloth. Put that cloth in an approved container when disconnection is completed.

- Never run engine with fuel pump relay disconnected when engine and exhaust system are hot.
- Fuel or fuel vapor hose connection varies with each type of pipe. When reconnecting fuel or fuel vapor hose, be sure to connect and clamp each hose correctly referring to left figure. After connecting, make sure that the hose has no twist or kink.
- When installing fuel union bolt gasket, always use new gasket and tighten union bolt to specified torque.
- When installing injector, fuel feed pipe or fuel pressure regulator, lubricate its O-ring with gasoline.
- When connecting fuel pipe flare nut, first tighten flare nut by hand and then tighten it to specified torque.

**FUEL PRESSURE RELIEF PROCEDURE****CAUTION:**

This work must not be done when engine is hot. If done so, it may cause adverse effect to catalyist.

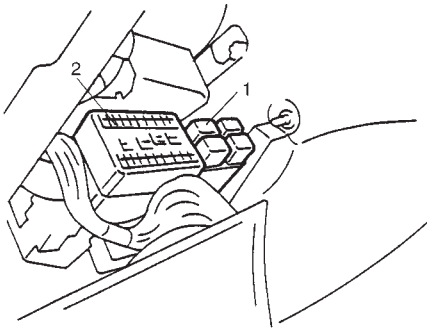
**Left hand steering vehicle**

1. Fuel pump relay
2. Fuse box

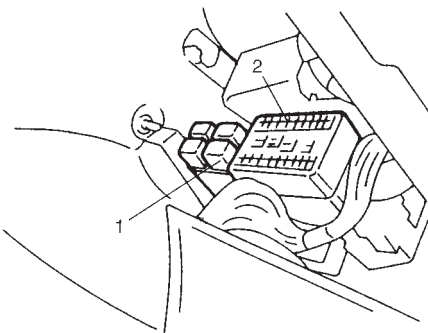
**Right hand steering vehicle**

1. Fuel pump relay
2. Fuse box

After making sure that engine is cold, relief fuel pressure as follows.

- 1) Place transmission gear shift lever in "Neutral" (shift selector lever to "P" range for A/T vehicle), set parking brake, and block drive wheels.
- 2) Remove fuel pump relay from relay box.
- 3) Remove fuel filler cap to release fuel vapor pressure in fuel tank and then reinstall it.
- 4) Start engine and run it till it stops for lack of fuel. Repeat cranking engine 2 – 3 times of about 3 seconds each time to dissipate fuel pressure in lines. Fuel connections are now safe for servicing.
- 5) Upon completion of servicing, install fuel pump relay to relay box.

## **FUEL LEAKAGE CHECK PROCEDURE**

After performing any service on fuel system, check to make sure that there are no fuel leakages as follows.

- 1) Turn ON ignition switch for 3 seconds (to operate fuel pump) and then turn it OFF.

Repeat this (ON and OFF) 3 or 4 times and apply fuel pressure to fuel line (till fuel pressure is felt by hand placed on fuel return hose).

- 2) In this state, check to see that there are no fuel leakages from any part of fuel system.

# ENGINE DIAGNOSIS

## GENERAL DESCRIPTION

This vehicle is equipped with an engine and emission control system which are under control of ECM (PCM). The engine and emission control system in this vehicle are controlled by ECM (PCM). ECM (PCM) has an On-Board Diagnostic system which detects a malfunction in this system and abnormality of those parts that influence the engine exhaust emission. When diagnosing engine troubles, be sure to have full understanding of the outline of "ON-BOARD DIAGNOSTIC SYSTEM" and each item in "PRECAUTION IN DIAGNOSING TROUBLE" and execute diagnosis according to "ENGINE DIAGNOSTIC FLOW TABLE" in this section.

There is a close relationship between the engine mechanical, engine cooling system, ignition system, exhaust system, etc. and the engine and emission control system in their structure and operation. In case of an engine trouble, even when the malfunction indicator lamp (MIL) doesn't turn ON, it should be diagnosed according to "ENGINE DIAGNOSTIC FLOW TABLE" in this section.

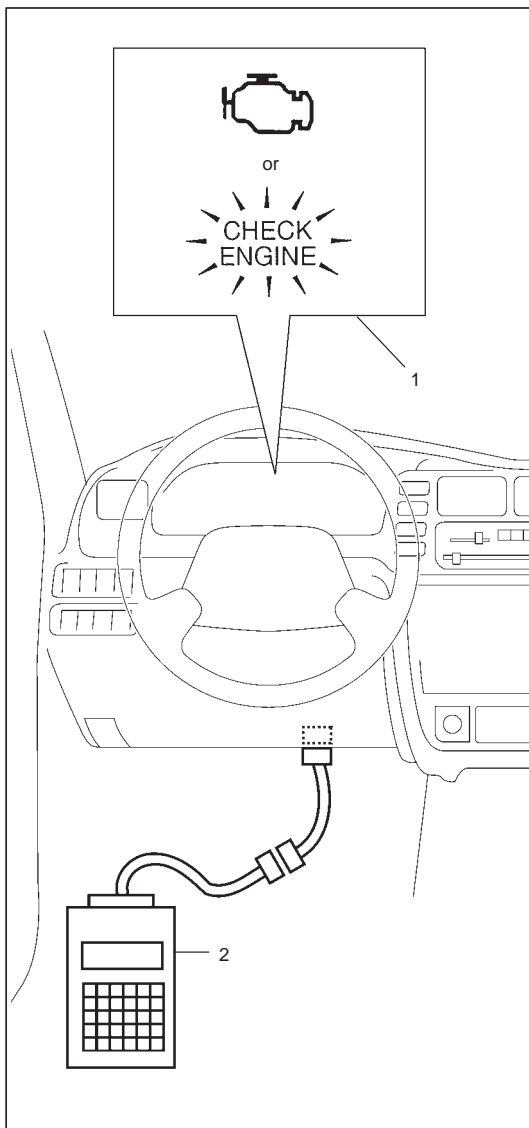

## ON-BOARD DIAGNOSTIC SYSTEM (VEHICLE WITHOUT MONITOR CONNECTOR)

ECM (PCM) in this vehicle has following functions.

- When the ignition switch is turned ON with the engine at a stop, MIL (1) turns ON to check the bulb of the malfunction indicator lamp (MIL).
- When ECM (PCM) detects a malfunction which gives an adverse effect to vehicle emission while the engine is running, it makes the malfunction indicator lamp in the meter cluster of the instrument panel turn ON or flash (flashing only when detecting a misfire which can cause damage to the catalyst) and stores the malfunction area in its memory.  
(If it detects that continuously 3 driving cycles are normal after detecting a malfunction, however, it makes MIL turn OFF although DTC stored in its memory will remain.)
- As a condition for detecting a malfunction in some areas in the system being monitored by ECM (PCM) and turning ON the malfunction indicator lamp due to that malfunction, 2 driving cycle detection logic is adopted to prevent erroneous detection.
- When a malfunction is detected, engine and driving conditions then are stored in ECM (PCM) memory as freeze frame data. (For the details, refer to description on Freeze frame data.)
- It is possible to communicate by using not only SUZUKI scan tool (Tech-1) (2) but also generic scan tool. (Diagnostic information can be accessed by using a scan tool.)

## Warm-Up Cycle

A warm-up cycle means sufficient vehicle operation such that the coolant temperature has risen by at least 22°C (40°F) from engine starting and reaches a minimum temperature of 70°C (160°F).

## Driving Cycle

A “Driving Cycle” consists of engine startup and engine shutoff.

## 2 Driving Cycles Detection Logic

The malfunction detected in the first driving cycle is stored in ECM (PCM) memory (in the form of pending DTC and freeze frame data) but the malfunction indicator lamp does not light at this time. It lights up at the second detection of same malfunction also in the next driving cycle.

## Pending DTC

Pending DTC means a DTC detected and stored temporarily at 1 driving cycle of the DTC which is detected in the 2 driving cycles detection logic.

### An Example of Freeze Frame Data

1. TROUBLE CODE	P0102	(1st)
2. COOLANT TEMP.	80°C	↑
3. ENGINE SPEED	750 RPM	
4. SHORT FT B1	-0.8 %	
5. SHORT FT B2	-0.1 %	
6. LONG FT B1	-1.3 %	
7. LONG FT B2	-1.5 %	
8. CALC LOAD	20.5 %	
9. FUEL SYSTEM B1	CLOSED	
10. FUEL SYSTEM B2	CLOSED	
11. MAP	30.6 kPa	
12. VEHICLE SPEED	0 km/h	

1st, 2nd or 3rd in parentheses here represents which position in the order the malfunction is detected.

## Freeze Frame Data

ECM (PCM) stores the engine and driving conditions (in the form of data as shown at the left) at the moment of the detection of a malfunction in its memory. This data is called “Freeze frame data”.

Therefore, it is possible to know engine and driving conditions (e.g., whether the engine was warm or not, where the vehicle was running or stopped, where air/fuel mixture was lean or rich) when a malfunction was detected by checking the freeze frame data. Also, ECM (PCM) has a function to store each freeze frame data for three different malfunctions in the order as the malfunction is detected. Utilizing this function, it is possible to know the order of malfunctions that have been detected. Its use is helpful when rechecking or diagnosing a trouble.

## Priority of freeze frame data:

ECM (PCM) has 4 frames where the freeze frame data can be stored. The first frame stores the freeze frame data of the malfunction which was detected first. However, the freeze frame data stored in this frame is updated according to the priority described below. (If malfunction as described in the upper square “1” below is detected while the freeze frame data in the lower square “2” has been stored, the freeze frame data “2” will be updated by the freeze frame data “1”.)

PRIORITY	FREEZE FRAME DATA IN FRAME 1
1	Freeze frame data at initial detection of malfunction among misfire detected (P0300-P0306), fuel system too lean (P0171, P0174) and fuel system too rich (P0172, P0175).
2	Freeze frame data when a malfunction other than those in “1” above is detected.

In the 2nd through the 4th frames, the freeze frame data of each malfunction is stored in the order as the malfunction is detected. These data are not updated regardless of the priority. Shown in the table below are examples of how freeze frame data are stored when two or more malfunctions are detected.

MAL-FUNCTION DETECTED ORDER		FRAME	FRAME 1	FRAME 2	FRAME 3	FRAME 4
			FREEZE FRAME DATA to be updated	1st FREEZE FRAME DATA	2nd FREEZE FRAME DATA	3rd FREEZE FRAME DATA
	No malfunction		No freeze frame data	No freeze frame data	No freeze frame data	No freeze frame data
1	P0112 (IAT) detected		Data at P0112 detection	Data at P0112 detection	No freeze frame data	No freeze frame data
2	P0171 (Fuel system) detected		Data at P0171 detection	Data at P0112 detection	Data at P0171 detection	No freeze frame data
3	P0300 (Misfire) detected		Data at P0171 detection	Data at P0112 detection	Data at P0171 detection	Data at P0300 detection
4	P0301 (Misfire) detected		Data at P0171 detection	Data at P0112 detection	Data at P0171 detection	Data at P0300 detection

#### Freeze frame data clearance:

The freeze frame data is cleared at the same time as clearance of DTC.

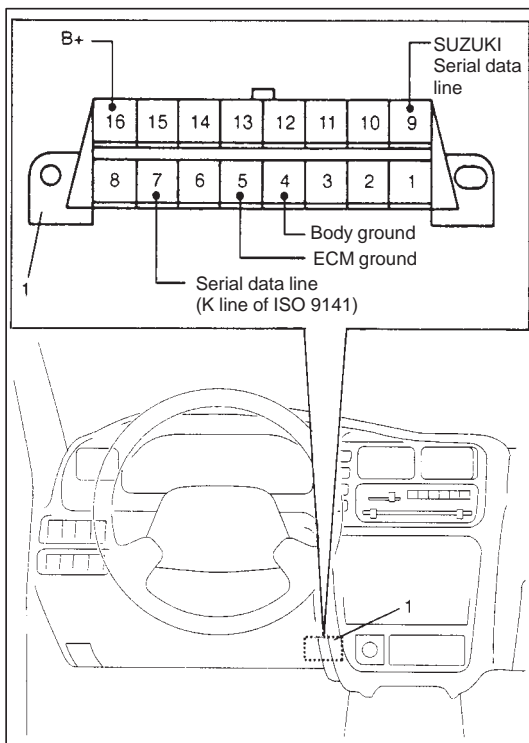

#### Data Link Connector (DLC)

DLC (1) is in compliance with SAEJ1962 in its installation position, the shape of connector and pin assignment.

Serial data line (K line of ISO 9141) is used for SUZUKI scan tool (Tech-1) or generic scan tool to communicate with ECM (PCM) and ABS control module. SUZUKI serial data line is used for SUZUKI scan tool (Tech-1) to communicate with an electronic control unit (Airbag SDM, etc.).

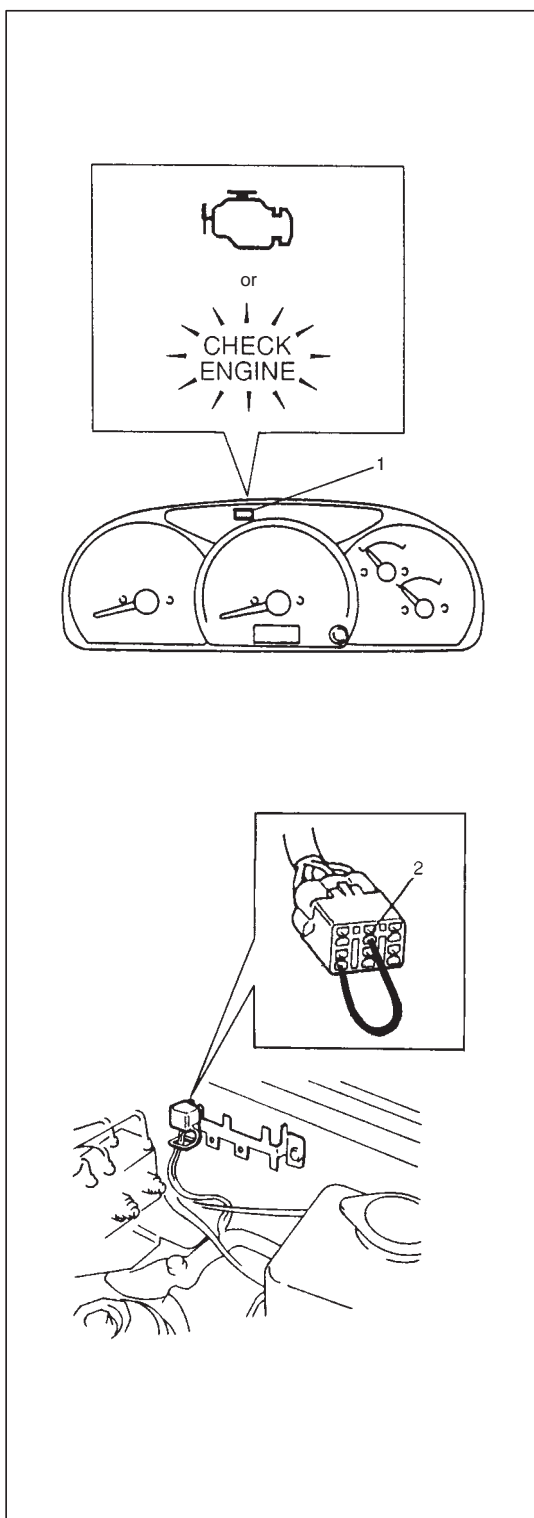

## ON-BOARD DIAGNOSTIC SYSTEM (VEHICLE WITH MONITOR CONNECTOR)

ECM diagnosis troubles which may occur in the area including the following parts when the ignition switch is ON and the engine is running, and indicates the result by turning on or flashing malfunction indicator lamp (1).

- Heated oxygen sensor
- ECT sensor
- TP sensor
- IAT sensor
- MAP sensor
- CMP sensor
- MAF sensor
- VSS
- CPU (Central Processing Unit) of ECM
- EGR valve (if equipped)
- CKP sensor (if equipped)

ECM and malfunction indicator lamp (1) operate as follows.

- Malfunction indicator lamp (1) lights when the ignition switch is turned ON (but the engine at stop) with the diagnosis switch terminal ungrounded regardless of the condition of Electronic Fuel Injection system. This is only to check the malfunction indicator lamp (1) bulb and its circuit.
- If the above areas of Electronic Fuel Injection system is free from any trouble after the engine start (while engine is running), malfunction indicator lamp (1) turns OFF.
- When ECM detects a trouble which has occurred in the above areas, it makes malfunction indicator lamp (1) turn ON while the engine is running to warn the driver of such occurrence of trouble and at the same time it stores the trouble area in ECM back-up memory. (The memory is kept as it is even if the trouble was only temporary and disappeared immediately. And it is not erased unless the power to ECM is shut off for specified time below.)  
ECM also indicates trouble area in memory by means of flashing of malfunction indicator lamp (1) at the time of inspection. (I.e. when diagnosis switch terminal (2) is grounded and ignition switch is turned ON.)

### NOTE:

- **When a trouble occurs in the above areas and disappears soon while the diagnosis switch terminal is ungrounded and the engine is running, malfunction indicator lamp (1) lights and remains ON as long as the trouble exists but it turns OFF when the normal condition is restored.**

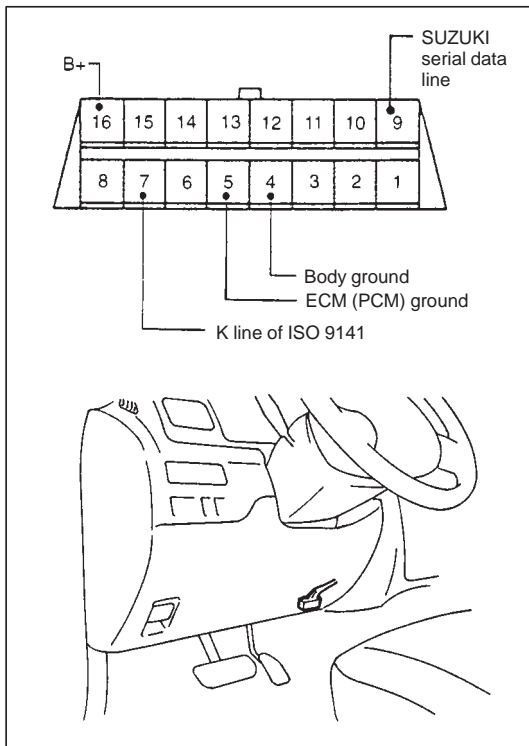

### Data Link Connector (DLC)

DLC in compliance with SAE J1962 in its installation position, the shape of connector and pin assignment.

K line of ISO 9141 is used for SUZUKI scan tool to communication with ECM (PCM) and ABS control module. SUZUKI serial data line is used for SUZUKI scan tool to communicate with an electronic control units (Airbag SDM, etc.).

## PRECAUTION IN DIAGNOSING TROUBLE

- Don't disconnect couplers from ECM (PCM), battery cable from battery, ECM (PCM) ground wire harness from engine or main fuse before confirming diagnostic information (DTC, freeze frame data, etc.) stored in ECM (PCM) memory. Such disconnection will erase memorized information in ECM (PCM) memory.
- Diagnostic information stored in ECM (PCM) memory can be cleared as well as checked by using SUZUKI scan tool (Tech-1) or generic scan tool. Before using scan tool, read its Operator's (Instruction) Manual carefully to have good understanding as to what functions are available and how to use it.
- Priorities for diagnosing troubles (vehicle without monitor connector).

If two or more diagnostic trouble codes (DTCs) are stored, proceed to the flow table of the DTC which was detected earliest in the order and follow the instruction in that table.

If no instructions are given, troubleshoot diagnostic trouble codes according to the following priorities.

1. Diagnostic trouble codes (DTCs) other than DTC P0171/P0172/P0174/P0175 (Fuel system too lean/too rich), DTC P0300/P0301/P0302/P0303/P0304/P0305/P0306 (Misfire detected) and DTC P0400 (EGR flow malfunction)
  2. DTC P0171/P0172/P0174/P0175 (Fuel system too lean/too rich) and DTC P0400 (EGR flow malfunction)
  3. DTC P0300/P0301/P0302/P0303/P0304/P0305/P0306 (Misfire detected)
- Be sure to read "PRECAUTIONS FOR ELECTRICAL CIRCUIT SERVICE" in "GENERAL INFORMATION" section before inspection and observe what is written there.
  - ECM (PCM) Replacement  
When substituting a known-good ECM (PCM), check for following conditions. Neglecting this check may cause damage to a known-good ECM (PCM).
    - Resistance value of all relays, actuators is as specified respectively.
    - MAP sensor and TP sensor are in good condition and none of power circuits of these sensors is shorted to ground.

## ENGINE DIAGNOSTIC FLOW TABLE

Refer to following pages for the detail of each step.

STEP	ACTION	YES	NO
1	Customer Complaint Analysis 1) Perform customer complaint analysis. Was customer complaint analysis performed?	Go to Step 2.	Perform customer complaint analysis.
2	DTC(s)/Freeze Frame Data Check 1) Check DTC(s)/Freeze frame data. Is there any malfunction DTC(s)?	1) Record DTC(s)/ Freeze frame data. 2) Clear DTC(s). Go to Step 3.	Go to Step 4.
3	Visual Inspection 1) Perform visual inspection. Is there any faulty condition?	1) Repair or replace malfunction part. Go to Step 11.	Go to Step 5.
4	Visual Inspection 1) Perform visual inspection. Is there any faulty condition?	1) Repair or replace malfunction part. Go to Step 11.	Go to Step 8.
5	Trouble Symptom Confirmation 1) Confirm trouble symptom based on customer complaint analysis, DTC(s)/freeze frame data in Step 1. Is trouble symptom identified?	Go to Step 6.	Go to Step 7.
6	DTC/Freeze Frame Data Recheck 1) Recheck DTC/freeze frame data. Is there any malfunction DTC(s)?	Go to Step 9.	Go to Step 8.
7	DTC/Freeze Frame Data Recheck 1) Recheck DTC/freeze frame data. Is there any malfunction DTC(s)?	Go to Step 9.	Go to Step 10.
8	Engine Basic Inspection 1) Check and repair according to "ENGINE BASIC INSPECTION FLOW TABLE" and "ENGINE DIAGNOSIS TABLE" in this section. Are check and repair complete?	Go to Step 11.	1) Check and repair malfunction part(s). Go to Step 11.
9	DTC Trouble Shooting 1) Check and repair according to applicable "DTC Diag. flow table" in this section. Are check and repair complete?	Go to Step 11.	1) Check and repair malfunction part(s). Go to Step 11.
10	Intermittent Problems Check 1) Check for intermittent problems referring to "Check for Intermittent Problem" in "GENERAL INFORMA- TION" section. Is there any faulty condition?	1) Repair or replace malfunction part. Go to Step 11.	Go to Step 11.
11	Final Confirmation Test 1) Clear DTC if any. 2) Perform final confirmation test referring to "DTC CONFIRMATION PROCEDURE" in this section. Is there any problem symptom, malfunction DTC or abnormal condition?	Go to Step 6.	END.

## 1. CUSTOMER COMPLAINT ANALYSIS

Record details of the problem (failure, complaint) and how it occurred as described by the customer. For this purpose, use of such an inspection form will facilitate collecting information to the point required for proper analysis and diagnosis.

### CUSTOMER PROBLEM INSPECTION FORM (EXAMPLE)

User name:	Model:	VIN:	
Date of issue:	Date of reg.:	Date of problem:	Mileage:

PROBLEM SYMPTOMS	
<input type="checkbox"/> <b>Difficult Starting</b> <input type="checkbox"/> No cranking <input type="checkbox"/> No initial combustion <input type="checkbox"/> No combustion <input type="checkbox"/> Poor starting at ( <input type="checkbox"/> cold <input type="checkbox"/> warm <input type="checkbox"/> always ) <input type="checkbox"/> Other _____	<input type="checkbox"/> <b>Poor Driveability</b> <input type="checkbox"/> Hesitation on acceleration <input type="checkbox"/> Back fire/ <input type="checkbox"/> After fire <input type="checkbox"/> Lack of power <input type="checkbox"/> Surging <input type="checkbox"/> Abnormal knocking <input type="checkbox"/> Other _____
<input type="checkbox"/> <b>Poor Idling</b> <input type="checkbox"/> Poor fast idle <input type="checkbox"/> Abnormal idling speed ( <input type="checkbox"/> High <input type="checkbox"/> Low ) ( _____ r/min. ) <input type="checkbox"/> Unstable <input type="checkbox"/> Hunting ( _____ r/min. to _____ r/min. ) <input type="checkbox"/> Other _____	<input type="checkbox"/> <b>Engine Stall when</b> <input type="checkbox"/> Immediately after start <input type="checkbox"/> Accel. pedal is depressed <input type="checkbox"/> Accel. pedal is released <input type="checkbox"/> Load is applied <input type="checkbox"/> A/C <input type="checkbox"/> Electric load <input type="checkbox"/> P/S <input type="checkbox"/> Other _____
<input type="checkbox"/> OTHERS:	

VEHICLE/ENVIRONMENTAL CONDITION WHEN PROBLEM OCCURS	
<b>Environmental Condition</b>	
Weather	<input type="checkbox"/> Fair <input type="checkbox"/> Cloudy <input type="checkbox"/> Rain <input type="checkbox"/> Snow <input type="checkbox"/> Always <input type="checkbox"/> Other _____
Temperature	<input type="checkbox"/> Hot <input type="checkbox"/> Warm <input type="checkbox"/> Cool <input type="checkbox"/> Cold ( _____ °F/ _____ °C ) <input type="checkbox"/> Always
Frequency	<input type="checkbox"/> Always <input type="checkbox"/> Sometimes ( _____ times/ _____ day, month ) <input type="checkbox"/> Only once <input type="checkbox"/> Under certain condition
Road	<input type="checkbox"/> Urban <input type="checkbox"/> Suburb <input type="checkbox"/> Highway <input type="checkbox"/> Mountainous ( <input type="checkbox"/> Uphill <input type="checkbox"/> Downhill ) <input type="checkbox"/> Tarmacadam <input type="checkbox"/> Gravel <input type="checkbox"/> Other _____
<b>Vehicle Condition</b>	
Engine Condition	<input type="checkbox"/> Cold <input type="checkbox"/> Warming up phase <input type="checkbox"/> Warmed up <input type="checkbox"/> Always <input type="checkbox"/> Other at starting <input type="checkbox"/> Immediately after start <input type="checkbox"/> Racing without load <input type="checkbox"/> Engine speed ( _____ r/min )
Vehicle Condition	<input type="checkbox"/> During driving: <input type="checkbox"/> Constant speed <input type="checkbox"/> Accelerating <input type="checkbox"/> Decelerating <input type="checkbox"/> Right hand corner <input type="checkbox"/> left hand corner <input type="checkbox"/> When shifting (Lever position _____ ) <input type="checkbox"/> At stop <input type="checkbox"/> Vehicle speed when problem occurs ( _____ km/h, _____ Mile/h ) <input type="checkbox"/> Other _____

Malfunction Indicator Lamp Condition	<input type="checkbox"/> Always ON <input type="checkbox"/> Sometimes ON <input type="checkbox"/> Always OFF <input type="checkbox"/> Good condition
Diagnostic Trouble Code	First check: <input type="checkbox"/> No code <input type="checkbox"/> Normal code <input type="checkbox"/> Malfunction code ( _____ )
	Second check: <input type="checkbox"/> No code <input type="checkbox"/> Normal code <input type="checkbox"/> Malfunction code ( _____ )

#### NOTE:

The above form is a standard sample. It should be modified according to conditions characteristic of each market.

## 2. DIAGNOSTIC TROUBLE CODE (DTC)/FREEZE FRAME DATA CHECK

First, check DTC, referring to “DIAGNOSTIC TROUBLE CODE CHECK” in this section. If DTC is indicated, record DTC and freeze frame data.

- After that clear DTC referring to “DIAGNOSTIC TROUBLE CODE CLEARANCE” in this section. DTC indicates malfunction that occurred in the system but does not indicate whether it exists now or it occurred in the past and the normal condition has been restored now. To check which case applies, check the symptom in question according to Step 5 and recheck DTC according to Step 6, 7.

Attempt to diagnose a trouble based on DTC in this step only or failure to clear the DTC (including pending DTC) in this step will lead to incorrect diagnosis, trouble diagnosis of a normal circuit or difficulty in troubleshooting.

### NOTE:

**For A/T vehicle, if only DTC P0705 (No.72), P0715 (No.76), P0720 (No.75), P0741, P0743 (No. 65/66), P0751, P0753, P0756, P0758 (No. 63/64), or P1875 is indicated in this step, proceed to DIAGNOSIS in “AUTOMATIC TRANSMISSION” section.**

## 3. and 4. VISUAL INSPECTION

Be sure to perform visual check of the following items that support proper function of the engine.

INSPECTION ITEM	REFERRING SECTION
<ul style="list-style-type: none"> <li>● Engine oil – – – – – level, leakage</li> <li>● Engine coolant – – – – – level, leakage</li> <li>● Fuel – – – – – level, leakage</li> <li>● A/T fluid – – – – – level, leakage</li> <li>● Air cleaner element – – – – – dirt, clogging</li> <li>● Battery – – – – – fluid level, corrosion of terminal</li> <li>● Water pump belt and/or cooling fan belt – – – – – tension, damage</li> <li>● Accelerator cable – – – – – play, installation</li> <li>● A/T throttle cable – – – – – play, installation</li> <li>● Vacuum hoses of air intake system – – – – – disconnection, looseness, deterioration, bend</li> <li>● Connectors of electric wire harness – – – – – disconnection, friction</li> <li>● Fuses – – – – – burning</li> <li>● Parts – – – – – installation, bolt – – – – – looseness</li> <li>● Parts – – – – – deformation</li> <li>● Other parts that can be checked visually</li> </ul> <p>Also check following items at engine start, if possible</p> <ul style="list-style-type: none"> <li>● Malfunction indicator lamp – – – – – operation</li> <li>● Charge warning lamp – – – – – operation</li> <li>● Engine oil pressure warning lamp – – – – – operation</li> <li>● Engine coolant temp. meter – – – – – operation</li> <li>● Fuel lever meter – – – – – operation</li> <li>● Abnormal air being inhaled from air intake system</li> <li>● Exhaust system – – – – – leakage of exhaust gas, noise</li> <li>● Other parts that can be checked visually</li> </ul>	<p>MAINTENANCE AND LUBRICATION section</p> <p>MAINTENANCE AND LUBRICATION section</p> <p>MAINTENANCE AND LUBRICATION section</p> <p>MAINTENANCE AND LUBRICATION section</p> <p>MAINTENANCE AND LUBRICATION section</p> <p>MAINTENANCE AND LUBRICATION section</p> <p>ENGINE AND EMISSION CONTROL SYSTEM section</p> <p>ENGINE AND EMISSION CONTROL SYSTEM section</p> <p>BODY ELECTRICAL SYSTEM section</p> <p>ENGINE DIAGNOSIS section</p> <p>CHARGING SYSTEM section</p> <p>BODY ELECTRICAL SYSTEM section/ ENGINE MECHANICAL section</p> <p>BODY ELECTRICAL SYSTEM section</p> <p>BODY ELECTRICAL SYSTEM section</p>

## 5. TROUBLE SYMPTOM CONFIRMATION

Based on information obtained in Step 1 "CUSTOMER COMPLAINT ANALYSIS" and Step 2 "DTC/FREEZE FRAME DATA CHECK", confirm trouble symptoms. Also, reconfirm DTC according to "DTC CONFORMATION PROCEDURE" described in each "DTC FLOW TABLE".

## 6. and 7. RECHECKING AND RECORD OF DTC

Refer to "DTC Check" in this section for checking procedure.

## 8. ENGINE BASIC INSPECTION AND ENGINE DIAGNOSIS TABLE

Perform basic engine check according to the "ENGINE BASIC INSPECTION FLOW TABLE" first. When the end of the flow table has been reached, check the parts of the system suspected as a possible cause referring to "ENGINE DIAGNOSIS TABLE" and based on symptoms appearing on the vehicle (symptoms obtained through steps of customer complaint analysis, trouble symptom confirmation and/or basic engine check) and repair or replace faulty parts, if any.

**ENGINE BASIC INSPECTION FLOW TABLE**

STEP	ACTION	YES	NO
1	Was "ENGINE DIAG. FLOW TABLE" performed?	Go to Step 2.	Go to "ENGINE DIAG. FLOW TABLE".
2	Check battery voltage. Is it 11 V or more?	Go to Step 3.	Charge or replace battery.
3	Is engine cranked?	Go to Step 4.	Go to "DIAGNOSIS" in "CRANKING SYSTEM" section.
4	Does engine start?	Go to Step 5.	Go to Step 7.
5	Check engine idle speed/IAC duty referring to "Idle Speed/IAC Duty Inspection" in "ENGINE AND EMISSION CONTROL" section. Is check result as specified?	Go to Step 6.	Go to "ENGINE DIAGNOSIS TABLE" in this section.
6	Check ignition timing referring to "Ignition Timing Inspection" in "IGNITION SYSTEM" section. Is check result as specified?	Go to "ENGINE DIAGNOSIS TABLE" in this section.	Adjust ignition timing.
7	Check fuel supply as follows: 1) Check to make sure that enough fuel is filled in fuel tank. 2) Turn ON ignition switch for 3 seconds and then OFF. Repeat this a few times. Is fuel return pressure (returning sounds) felt from fuel return hose when ignition switch is turned ON?	Go to Step 9.	Go to Step 8.
8	Check fuel pump for operating. 1) Was fuel pump operating sound heard from fuel filler for about 3 seconds after ignition switch ON and stop?	Go to "Diag. Flow Table B-3" in this section.	Go to "Diag. Flow Table B-1" in this section.
9	Check ignition spark referring to "Ignition Spark Test" in "IGNITION SYSTEM" section. Is it in good condition?	Go to Step 10.	Go to "DIAGNOSIS" in "IGNITION SYSTEM" section.
10	Check fuel injector referring to "Fuel Injector Inspection" in "ENGINE AND EMISSION CONTROL" section. Is it in good condition?	Go to "ENGINE DIAGNOSIS TABLE" in this section.	Go to "Diag. Flow Table B-2" in this section.

**9. TROUBLESHOOTING FOR DTC**

Based on the DTC indicated in Step 6 or 7 and referring to the applicable DTC diag. flow table in this section, locate the cause of the trouble, namely in a sensor, switch, wire harness, connector, actuator, ECM (PCM) or other part and repair or replace faulty parts.

**10. CHECK FOR INTERMITTENT PROBLEM**

Check parts where an intermittent trouble is easy to occur (e.g., wire harness, connector, etc.), referring to "Intermittent And Poor Connection" in "GENERAL INFORMATION" section and related circuit of DTC recorded in step 2.

**11. FINAL CONFIRMATION TEST**

Confirm that the problem symptom has gone and the engine is free from any abnormal conditions. If what has been repaired is related to the DTC, clear the DTC once, perform DTC confirmation procedure and confirm that no malfunction DTC (a normal code) is indicated.

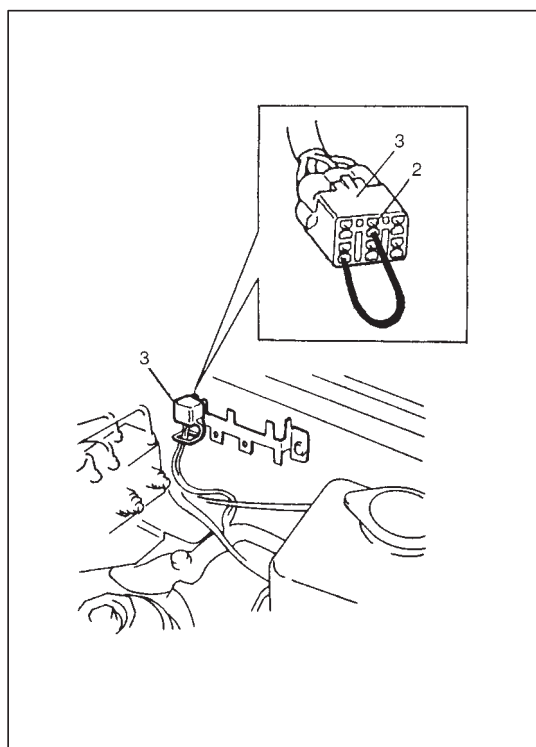
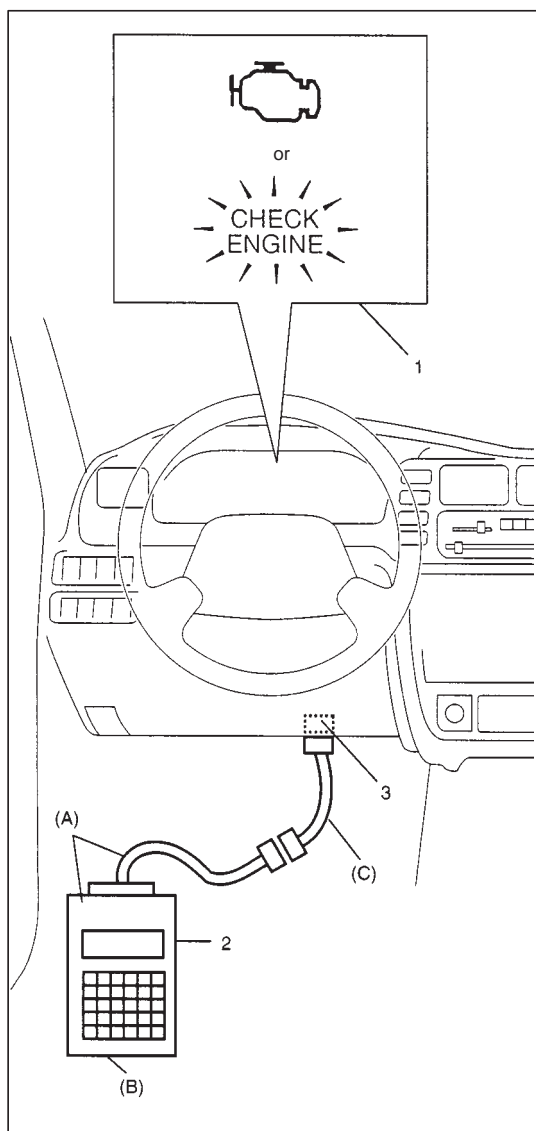

## MALFUNCTION INDICATOR LAMP (MIL) CHECK

- 1) Turn ON ignition switch (but the engine at stop) and check that MIL (1) lights.  
If MIL does not light up, go to "Diagnostic Flow Table A-1" for troubleshooting.
- 2) Start engine and check that MIL turns OFF.  
If MIL remains ON, and no DTC is stored in ECM (PCM), go to "Diagnostic Flow Table A-2" for troubleshooting.

## DIAGNOSTIC TROUBLE CODE (DTC) CHECK

### [Using scan tool]

- 1) Prepare generic scan tool (2) or SUZUKI scan tool (Tech-1).
- 2) With ignition switch OFF, connect it to data link connector (DLC) (3) located on underside of instrument panel at driver's seat side.

### Special Tool

(A): SUZUKI scan tool

(B): Mass storage cartridge

(C): 16/14 pin DLC cable (OBD-II adapter cable)

- 3) Turn ignition switch ON and confirm that MIL lights.
- 4) Read DTC and freeze frame data according to instructions displayed on scan tool and print them or write them down. Refer to scan tool operator's manual for further details.

If communication between scan tool and ECM (PCM) is not possible, check if scan tool is communicable by connecting it to ECM (PCM) in another vehicle. If communication is possible in this case, scan tool is good condition. Then check data link connector and serial data line (circuit) in the vehicle with which communication was not possible.

- 5) After completing the check, turn ignition switch off and disconnect scan tool from data link connector.

### [Not using SUZUKI scan tool] (vehicle with monitor connector)

- 1) Check malfunction indicator lamp referring to "Malfunction Indicator Lamp Check" in this section.
- 2) With the ignition switch OFF position, disconnect SUZUKI scan tool if connected and using service wire (1), ground diagnosis switch terminal (2) in monitor coupler (3).
- 3) With the ignition switch ON position and leaving engine OFF, read DTC from flashing pattern of malfunction indicator lamp. Refer to "DIAGNOSTIC TROUBLE CODE TABLE".  
If lamp remains ON, go to "Diagnostic Flow Table A-1".

### NOTE:

● If abnormality or malfunction lies in two or more areas, malfunction indicator lamp indicates applicable codes three times each.

And flashing of these codes is repeated as long as diagnosis terminal is grounded and ignition switch is held at ON position.

● Take a note of diagnostic trouble code indicated first.

- 4) After completing the check, turn the ignition switch OFF position and disconnect service wire from monitor coupler.

## DIAGNOSTIC TROUBLE CODE (DTC) CLEARANCE

### [Using scan tool]

- 1) With ignition switch OFF, connect generic scan tool or SUZUKI scan tool (Tech-1) to data link connector (DLC).
- 2) Turn ignition switch ON.
- 3) Erase DTC according to instructions displayed on scan tool. Freeze frame data is cleared with the DTC. Refer to scan tool operator's manual for further details.
- 4) After completing the clearance, turn ignition switch off and disconnect scan tool from data link connector.

### NOTE:

**DTC and freeze frame data stored in ECM (PCM) memory are also cleared in following cases. Be careful not to clear them before keeping their record.**

- **When power to ECM (PCM) is cut off (by disconnecting battery cable, removing fuse or disconnecting ECM (PCM) connectors)**
- **When the same malfunction (DTC) is not detected again during 40 engine warm-up cycles (refer to "Warm-Up Cycle" of "ON-BOARD DIAGNOSTIC SYSTEM" in this section) (vehicle without monitor connector)**

### [Not using SUZUKI scan tool]

- 1) Turn the ignition switch OFF position.
- 2) Disconnect battery negative cable for specified time below to erase diagnostic trouble code stored in ECM memory and reconnect it.

### Time required to erase DTC:

Ambient temperature	Time to cut power to ECM
Over 0°C (32°F)	30 sec. or longer
Under 0°C (32°F)	Not specifiable. Select a place with higher than 0°C (32°F) temperature.

**DIAGNOSTIC TROUBLE CODE (DTC) TABLE**

<b>DTC NO.</b>	<b>DETECTING ITEM</b>	<b>DETECTING CONDITION (DTC will set when detecting:)</b>	<b>MIL (vehicle without monitor connector)</b>	<b>MIL (vehicle with monitor connector)</b>
P0100 (No.34)	Mass air flow circuit malfunction	Sensor output too low	1 driving cycle	1 driving cycle
P0100 (No.33)		Sensor output too high		
P0110 (No.25)	Intake air temp. circuit malfunction	Intake air temp. circuit low input	1 driving cycle	1 driving cycle
P0110 (No.23)		Intake air temp. circuit high input		
P0115 (No.15)	Engine coolant temp. circuit malfunction	Engine coolant temp. circuit low input	1 driving cycle	1 driving cycle
P0115 (No.14)		Engine coolant temp. circuit high input		
P0120 (No.22)	Throttle position circuit malfunction	Throttle position circuit low input	1 driving cycle	1 driving cycle
P0120 (No.21)		Throttle position circuit high input		
P0121	Throttle position circuit performance problem	Poor performance of TP sensor	2 driving cycles	Not applicable
P0130	HO2S circuit malfunction (Bank 1 – Sensor 1)	Min. output voltage of HO2S-1 is higher than specification.	2 driving cycles	Not applicable
		Max. output voltage of HO2S-1 is lower than specification.		
P0133	HO2S circuit slow response (Bank 1 – Sensor 1)	Response time of HO2S-1 output voltage between rich and lean is longer than specification.	2 driving cycles	Not applicable
P0134 (No.13)	HO2S (Bank 1 – Sensor 1) no activity detected	Output voltage of HO2S-1 fails to go above specification (or HO2S-1 circuit open).	2 driving cycles	2 driving cycles
P0135	HO2S heater circuit malfunction (Bank 1 – Sensor 1)	Terminal voltage is lower than specification at heater OFF or it is higher at heater ON.	2 driving cycles	Not applicable
P0136	HO2S circuit malfunction (Bank 1 – Sensor 2)	Max. voltage of HO2S-2 is lower than specification or its min. voltage is higher than specification.	2 driving cycles	Not applicable
P0141	HO2S heater circuit malfunction (Bank 1 – Sensor 2)	Terminal voltage is lower than specification at heater OFF or it is higher at heater ON.	2 driving cycles	Not applicable
P0150	HO2S circuit malfunction (Bank 2 – Sensor 1)	Max. output voltage of HO2S-1 is lower than specification.	2 driving cycles	Not applicable
P0153	HO2S circuit slow response (Bank 2 – Sensor 1)	Response time of HO2S-1 output voltage between rich and lean is longer than specification.	2 driving cycles	Not applicable

<b>DTC NO.</b>	<b>DETECTING ITEM</b>	<b>DETECTING CONDITION (DTC will set when detecting:)</b>	<b>MIL (vehicle without monitor connector)</b>	<b>MIL (vehicle with monitor connector)</b>
P0154 (No.26)	HO2S (Bank 2 – Sensor 1) no activity detected	Output voltage of HO2S-1 fails to go above specification (or HO2S-1 circuit open).	2 driving cycles	2 driving cycles
P0155	HO2S heater circuit malfunction (Bank 2 – Sensor 1)	Terminal voltage is lower than specification at heater OFF or it is higher at heater ON.	2 driving cycles	Not applicable
P0156	HO2S circuit malfunction (Bank 2 – Sensor 2)	Max. voltage of HO2S-2 is lower than specification or its min. voltage is higher than specification.	2 driving cycles	Not applicable
P0161	HO2S heater circuit malfunction (Bank 2 – Sensor 2)	Terminal voltage is lower than specification at heater OFF or it is higher at heater ON (or heater circuit or short).	2 driving cycles	Not applicable
P0171	Fuel system too lean (Bank 1)	Short term fuel trim or total fuel trim (short and long terms added) is larger than specification for specified time or longer. (Fuel trim toward rich side is large.)	2 driving cycles	Not applicable
P0172	Fuel system too rich (Bank 1)	Short term fuel trim or total fuel trim (short and long term added) is smaller than specification for specified time or longer. (Fuel trim toward lean side is large.)	2 driving cycles	Not applicable
P0174	Fuel system too lean (Bank 2)	Short term fuel trim or total fuel trim (short and long terms added) is larger than specification for specified time or longer. (Fuel trim toward rich side is large.)	2 driving cycles	Not applicable
P0175	Fuel system too rich (Bank 2)	Short term fuel trim or total fuel trim (short and long term added) is smaller than specification for specified time or longer. (Fuel trim toward lean side is large.)	2 driving cycles	Not applicable
P0300 P0301 P0302 P0303 P0304 P0305 P0306	Random misfire detected Cylinder 1 misfire detected Cylinder 2 misfire detected Cylinder 3 misfire detected Cylinder 4 misfire detected Cylinder 5 misfire detected Cylinder 6 misfire detected	Misfire of such level as to cause damage to three way catalyst	MIL flashing during misfire detection	Not applicable
P0305 P0306	Cylinder 5 misfire detected Cylinder 6 misfire detected	Misfire of such level as to deteriorate emission but not to cause damage to three way catalyst	2 driving cycles	Not applicable
P0335	Crankshaft position sensor circuit malfunction	No signal for 2 sec. during engine cranking	1 driving cycle	Not applicable
P0340 (No.42)	Camshaft position sensor circuit malfunction	No signal during engine running.	1 driving cycle	1 driving cycle
P0400	Exhaust gas recirculation flow malfunction detected	Excessive or insufficient EGR flow.	2 driving cycles	Not applicable

<b>DTC NO.</b>	<b>DETECTING ITEM</b>	<b>DETECTING CONDITION (DTC will set when detecting:)</b>	<b>MIL (vehicle without monitor connector)</b>	<b>MIL (vehicle with monitor connector)</b>
P0420	Catalyst system efficiency below threshold (Bank 1)	Output waveforms of HO2S-1 and HO2S-2 are similar. (Time from output voltage change of HO2S-1 to that of HO2S-2 is shorter than specification.)	2 driving cycles	Not applicable
P0430	Catalyst system efficiency below threshold (Bank 2)	Output waveforms of HO2S-1 and HO2S-2 are similar. (Time from output voltage change of HO2S-1 to that of HO2S-2 is shorter than specification.)	2 driving cycles	Not applicable
P0443	Purge control valve circuit malfunction	Purge control valve circuit is open or shorted to ground.	2 driving cycles	Not applicable
P0460	Fuel level sensor high input	Fuel level sensor circuit open (high voltage).	2 driving cycles	Not applicable
P0500 (No.24)	Vehicle speed sensor malfunction	No signal while running in "D" range or during fuel cut at decelerating.	1 driving cycle	1 driving cycle
P0505	Idle control system malfunction	No closed signal to IAC valve is detected.	2 driving cycles	1 driving cycle
P0601 (No.71)	Internal control module memory check sum error	Data write error (or check sum error) when written into ECM	1 driving cycle	Not applicable
P1408	Manifold absolute pressure sensor circuit malfunction	Manifold absolute pressure sensor output voltage is higher or lower than specified value (or sensor circuit shorted to ground or open).	2 driving cycles	Not applicable
P1450	Barometric pressure sensor circuit malfunction	Barometric pressure is lower or higher than specification (or sensor malfunction).	1 driving cycle	1 driving cycle
P1451	Barometric pressure sensor performance problem	Difference between manifold absolute pressure (MAP sensor value) and barometric pressure (barometric pressure sensor value) is larger than specification during cranking.	2 driving cycles	Not applicable
P1500	Starter signal circuit malfunction	Starter signal is not inputted from engine cranking till its start and after or it is always inputted.	2 driving cycles	Not applicable
P1510	ECM backup power source malfunction	No backup power after starting engine.	1 driving cycle	Not applicable

DTC NO.	DETECTING ITEM	DETECTING CONDITION (DTC will set when detecting:)	MIL
P0705 (No.72)	Transmission range circuit malfunction	Refer to Section 7B1	
P0715 (No.76)	Input/turbine speed sensor circuit malfunction		
P0720 (No.75)	A/T VSS signal circuit malfunction		
P0741	Torque converter clutch circuit performance or stuck off		
P0743 (No.65) (No.66)	Torque converter clutch circuit electrical		
P0751	Shift solenoid A (#1) performance or stuck off		
P0753 (No.61) (No.62)	Shift solenoid A (#1) electrical		
P0756	Shift solenoid B (#2) performance or stuck off		
P0758 (No.63) (No.64)	Shift solenoid B (#2) electrical		
P1875	4WD low switch circuit malfunction		
☆P1620 (No.84)	ECU code not registered		
☆P1621 (No.83)	NO ECU code transmitted from Immobilizer Control Module		
☆P1622 (No.82)	Fault in ECM		
☆P1623 (No.81)	ECU code not matched		

**NOTE:**

- For ( ) marked No. in DTC column, it is used for vehicle with monitor connector.
- DTC No.12 appears when none of the other codes is identified.
- With the generic scan tool, only star (☆) marked data in the above table can not be read.

**FAIL-SAFE TABLE**

When any of the following DTCs is detected, ECM enters fall-safe mode as long as malfunction continues to exist but that mode is canceled when ECM detects normal condition after that.

<b>DTC NO.</b>	<b>TROUBLE AREA</b>	<b>FAIL SAFE OPERATION</b>	<b>FAIL SAFE MODE REACTIVATION CONDITION</b>
P0100 (No.33, 34)	MAF SENSOR	Injector drive time (fuel injection volume) is determined according to throttle valve operating (idle position or not).	Detected value of MAF sensor output voltage is 0.3 V min. and 5.0 V max.
P0110 (No.23, 25)	IAT SENSOR	ENGINE control is performed on the basis of 40°C intake air temp.	Detected value of IAT sensor output voltage is 0.16 V min. and 5.00 V max.
P0115 (No.14, 15)	ECT SENSOR	<ul style="list-style-type: none"> <li>● ENGINE control is performed on the basis of 80°C engine coolant temp.</li> <li>● A/T control is performed on the basis of 31°C engine coolant temp.</li> </ul>	Detected value of ECT sensor output voltage is 0.16 V min. and 5.00 V max.
P0120 (No.21, 22)	TP SENSOR	<ul style="list-style-type: none"> <li>● ENGINE control is performed on the basis of 8 deg. throttle opening.</li> <li>● A/T control is performed on the basis of 0 % throttle position.</li> </ul>	Detected value of TP sensor output voltage is 0.10 V min. and 4.80 V max.
P0500 (No.24)	VEHICLE SPEED SENSOR	ENGINE control is performed on the basis of 10 km/h vehicle speed. And air flow at IAC valve is limited.	Vehicle speed sensor signal is detected.
P0705	TR SWITCH	A/T control is performed in priority order of L, 2, N, D and R when more than one of R, D, N, 2 and L signals are inputted simultaneously.	Single signal is inputted.
P0720	OUTPUT SPEED SENSOR CIRCUIT MALFUNCTION	A/T control is performed by using signal from VSS.	Detected vehicle speed signal is 10 km/h (6 mph) or more.
P0753	SHIFT SOLENOID A (#1)	SHIFT SOLENOID #1 : OFF SHIFT SOLENOID #2 : ON TCC SOLENOID : OFF	Monitor signal ON is detected when solenoid A (#1) is ON and monitor signal OFF is detected when it is OFF.
P0758	SHIFT SOLENOID B (#2)	SHIFT SOLENOID #1 : OFF SHIFT SOLENOID #2 : OFF TCC SOLENOID : OFF	Monitor signal ON is detected when solenoid B (#2) is ON and monitor signal OFF is detected when it is OFF.
P0743	TCC (LOCK-UP) SOLENOID	TCC (Lock-up) solenoid OFF	Monitor signal ON is detected when TCC control solenoid is ON and monitor signal OFF is detected when it is OFF.

## SCAN TOOL DATA

As the data values given below are standard values estimated on the basis of values obtained from the normally operating vehicles by using a scan tool, use them as reference values. Even when the vehicle is in good condition, there may be cases where the checked value does not fall within each specified data range. Therefore, judgment as abnormal should not be made by checking with these data alone.

Also, conditions in the below table that can be checked by the scan tool are those output from ECM (PCM) as Commands and there may be cases where the engine or actuator is not operating (in the condition) as indicated by the scan tool. Be sure to use the timing light to check the ignition timing.

### NOTE:

- For asterisk (※) marked item in OTHER column, item can be read only SUZUKI scan tool.
- When checking the data with the engine running at idle or racing, be sure to shift M/T gear to the neutral gear position and A/T gear to the “Park” position and pull the parking brake fully. Also, if nothing or “no load” is indicated, turn OFF A/C, all electric loads, P/S and all the other necessary switches.

SCAN TOOL DATA	CONDITION		NORMAL CONDITION/ REFERENCE VALUE	OTHER
COOLANT TEMP. (Engine Coolant Temp.)	At specified idle speed after warming up.		80 – 100°C (176 – 212°F)	
INTAKE AIR TEMP.	At specified idle speed after warming up.		Environmental temp. $\begin{matrix} +20^{\circ}\text{C} & (+36^{\circ}\text{F}) \\ -5^{\circ}\text{C} & (-9^{\circ}\text{F}) \end{matrix}$	
DESIRE IDLE (Desired Idle Speed)	At idling with no load after warming up.	Without monitor connector	675 rpm	※
		With monitor connector	750 rpm	
CLOSED THROT POS (Closed Throttle Position)	Ignition switch ON	Accelerator pedal released.	ON	※
		Accelerator pedal depressed.	OFF	
IAC FLOW DUTY	At specified idle speed after warming up.		10 – 50 %	※
ENGINE SPEED	At idling with no load after warming up.		Desired idle speed $\pm$ 50 rpm	
SHORT FT B1 (Short Term Fuel Trim)	At specified idle speed after warming up.		-20 ~ +20% -15 ~ +15 %	
SHORT FT B2 (Short Term Fuel Trim)	At specified idle speed after warming up.		-15 ~ +15 %	
LONG FT B1 (Long Term Fuel Trim)	At specified idle speed after warming up.		-15 ~ +15 %	
LONG FT B2 (Long Term Full Trim)	At specified idle speed after warming up.		-15 ~ +15 %	
IGNITION ADVANCE	At specified idle speed with no load after warming up.	Without monitor connector	6 – 12 deg.	
		With monitor connector	10 – 16 deg.	
BATTERY VOLTAGE	Ignition switch ON/engine stopped		10 – 14 V	※
MAF (Mass Air Flow Rate)	At specified idle speed with no load after warming up.		2.5 ~ 4.6 g/s 0.20 ~ 0.53 lb/min.	
	At 2500 r/min. with no load after warming up.		8.2 ~ 15.0 gm/s 0.66 ~ 1.32 lb/min.	
INJ PULSE WIDTH B1 (Fuel Injection Pulse Width)	At specified idle speed with no load after warming up.		2.0 ~ 3.4 msec	※
	At 2500 r/min. with no load after warming up.		2.0 ~ 3.4 msec	
INJ PULSE WIDTH B2	At specified idle speed with no load after warming up.		2.0 ~ 3.4 msec	※
	At 2500 r/min. with no load after warming up.		2.0 ~ 3.4 msec	

SCAN TOOL DATA	CONDITION		NORMAL CONDITION/ REFERENCE VALUE	OTHER
THROTTLE POS (Absolute Throttle Position)	Ignition switch ON/warmed up engine stopped.	Accelerator pedal released.	10 ± 5 %	
		Accelerator pedal depressed fully.	80 ± 10 %	
TP SENSOR VOLT (TP Sensor Output Voltage)	Ignition switch ON/warmed up engine stopped.	Accelerator pedal released.	0.35 ~ 0.65 V	*
		Accelerator pedal depressed fully.	3.0 ~ 3.8 V	
OXYGEN SENSOR B1 S1 (HO2S1 Output Voltage)	At specified idle speed after warming up.		0.05 ~ 0.95 V	
OXYGEN SENSOR B1 S2 (HO2S2 Output Voltage)	When engine is running at 2000 r/min. for 3 min or longer after warming up.		0.05 ~ 0.95 V	
OXYGEN SENSOR B2 S1 (HO2S2 Output Voltage)	When engine is running at 2000 r/min. for 3 min or longer after warming up.		0.05 ~ 0.95 V	
OXYGEN SENSOR B2 S2 (HO2S2 Output Voltage)	When engine is running at 2000 r/min. for 3 min or longer after warming up.		0.05 ~ 0.95 V	
FUEL SYSTEM B1 (Fuel System Status)	At specified idle speed after warming up.		Closed	*
FUEL SYSTEM B2 (Fuel System Status)	At specified idle speed after warming up.		Closed	
CALC LOAD (Calculated Load Value)	At specified idle speed with no load after warming up.		1.8 ~ 3.8 %	
	At 2500 r/min with no load after warming up.		6.0 ~ 11.5 %	
TOTAL FUEL TRIM B1	At specified idle speed after warming up.		-30 ~ +30 %	*
TOTAL FUEL TRIM B2	At specified idle speed after warming up.		-30 ~ +30 %	
MAP	At specified idle speed after warming up.		25 ~ 35 kPa	
CANIST PRG DUTY (EVAP Canister Purge Flow Duty)	At specified idle speed after warming up.		0 ~ 10 %	*
Vehicle Speed	At stop.		0 km/h 0MPH	
FUEL CUT	When engine is at fuel cut condition.		ON	*
	Other than fuel cut condition.		OFF	
EGR VALVE	At specified idle speed after warming up.		0 %	*
PSP SWITCH (if equipped)	Engine running at idle speed and steering wheel at straightahead position.		OFF	*
	Engine running at idle speed and steering wheel turned to the right or left as far as it stops.		ON	
A/C SWITCH (if equipped)	When A/C not operating.		OFF	*
	When A/C operating.		ON	
PNP SIGNAL (Transmission Range Switch) A/T only	Ignition switch ON	Selector lever in "P" or "N" position	P/N Range	*
		Selector lever in "R", "D", "2" or "L" position	D Range	
FUEL TANK LEVEL	Ignition switch ON		0 ~ 100 %	*

SCAN TOOL DATA	CONDITION	NORMAL CONDITION/ REFERENCE VALUE	OTHER
ELECTRIC LOAD	Ignition ON, small light OFF	OFF	*
	Ignition switch ON, small light ON	ON	*
VSS (for 4-A/T) (Vehicle Speed Sensor)	At stop.	0 km/h 0 MPH	*
GEAR POSITION (for 4-A/T)	Ignition switch ON, selector lever is shifted at "R", "D", "2" or "L" range and vehicle stops.	1st	*
THROT POS LEVEL (Throttle Position Level for 4-A/T)	"0"(about idle position), "1", "2", "3", "4", "5", "6" or "7" (about full open) appears according to throttle valve opening.		*
SHIFT SOL #1 (A) CON (Shift Solenoid #1 Com- mand Signal) MON (Shift Solenoid #1 Monitor)	Ignition switch ON Selector lever is shifted at "P", "R", "N", "D", "2" or "L" range. Vehicle stops.	ON	*
SHIFT SOL #2 (B) CON (Shift Solenoid #2 Com- mand Signal) MON (Shift Solenoid #2 Monitor)	Ignition switch ON Selector lever is shifted at "P", "R", "N", "D", "2" or "L" range. Vehicle stops.	OFF	*
TCC SOL CON (Torque Converter Clutch Solenoid Command Signal) MON (Torque Converter Clutch Solenoid Monitor)	Ignition switch ON Selector lever is shifted at "P", "R", "N", "D", "2" or "L" range. Vehicle stops.	OFF	*
TRANS RANGE	Ignition switch ON, selector lever is at "R", "N", "D", "2" or "L" range.	R, N, D, 2 or L	*
BRAKE SW (Brake, Stop Lamp, Switch)	Ignition switch ON, brake pedal is released.	OFF	*
	Ignition switch ON, brake pedal is depressed.	ON	
O/D OFF SW (Overdrive Cut Switch)	Ignition switch ON, overdrive cut switch OFF	OFF	*
	Ignition switch ON, overdrive cut switch ON	ON	
MODE SELECT SW (Power/Normal Change Switch)	Ignition switch ON, P/N change switch is at normal posi- tion.	NORMAL	*
	Ignition switch ON, P/N change switch is at power posi- tion.	POWER	
4WD-L SW (4WD Low Switch)	Ignition switch ON, transfer lever is shifted at "4H" or "2H" position.	OFF	*
	Ignition switch ON, transfer lever is shifted at "4L" posi- tion.	ON	
O/D & TCC OFF SIG	Ignition switch ON, vehicle stops.	OFF	*
BLOWER FAN	Ignition switch ON, blower fan switch OFF	OFF	
	Ignition switch ON, blower fan switch ON	ON	
A/C CONDENSER FAN	A/C is not operated.	OFF	
	A/C is operated.	ON	

## SCAN TOOL DATA DEFINITIONS

### COOLANT TEMP (ENGINE COOLANT TEMP., °C/°F)

It is detected by engine coolant temp. sensor.

### INTAKE AIR TEMP (°C/°F)

It is detected by intake air temp. sensor.

### DESIRE IDLE (DESIRED IDLE SPEED RPM)

The desired idle speed is an ECM (PCM) internal parameter which indicates the ECM (PCM) requested idle. If the engine is not running, the number is not valid.

### CLOSED THROT POS (CLOSED THROTTLE POSITION ON/OFF)

This parameter will read ON when the throttle valve is fully closed. Or OFF when the throttle is not fully closed.

### IAC FLOW DUTY (%)

This parameter indicates ON (valve open) time rate within a certain set cycle of IAC valve which controls bypass air flow.

### ENGINE SPEED (RPM)

It is computed by reference pulses from the Camshaft Position Sensor.

### SHORT FT B1 (SHORT TERM FUEL TRIM BANK 1, %)

### SHORT FT B2 (SHORT TERM FUEL TRIM BANK 2, %)

Short term fuel trim value represents short term corrections to the air/fuel mixture computation. A value of 0 indicates no correction, a value greater than 0 means an enrichment correction, and a value less than 0 implies an enleanment correction.

### LONG FT B1 (LONG TERM FUEL TRIM BANK 1, %)

### LONG FT B2 (LONG TERM FUEL TRIM BANK 2, %)

Long term fuel trim value represents long term corrections to the air/fuel mixture computation. A value of 0 indicates no correction, a value greater than 0 means an enrichment correction, and a value less than 0 implies an enleanment correction.

### IGNITION ADVANCE (IGNITION TIMING ADVANCE FOR NO.1 CYLINDER, deg)

Ignition timing of No.1 cylinder is commanded by ECM (PCM). The actual ignition timing should be checked by using the timing light.

### BATTERY VOLTAGE (V)

This parameter indicates battery positive voltage inputted from main relay to ECM (PCM).

### MAF (MASS AIR FLOW RATE, g/s, lb/min.)

It represents total mass of air entering intake manifold which is measured by mass air flow sensor.

### INJ PULSE WIDTH B1 (FUEL INJECTION PULSE WIDTH BANK 1, msec)

### INJ PULSE WIDTH B2 (FUEL INJECTION PULSE WIDTH BANK 2, msec)

This parameter indicates time of the injector drive (valve opening) pulse which is output from ECM (PCM).

### THROTTLE POS (ABSOLUTE THROTTLE POSITION, %)

When throttle position sensor is fully closed position, throttle opening is indicated as 0 % and 100 % for full open position.

### TP SENSOR VOLT (TP SENSOR OUTPUT VOLTAGE, V)

Throttle Position Sensor reading provides throttle valve opening information in the form of voltage.

### OXYGEN SENSOR B1 S1 (HO2S BANK 1 SENSOR 1 OUTPUT VOLTAGE, V)

### OXYGEN SENSOR B2 S1 (HO2S BANK 2 SENSOR 1 OUTPUT VOLTAGE, V)

It indicates output voltage of HO2S SENSOR 1 installed on exhaust manifold (pre-catalyst).

### OXYGEN SENSOR B1 S2 (HO2S BANK 1 SENSOR 2 OUTPUT VOLTAGE, V)

### OXYGEN SENSOR B1 S2 (HO2S BANK 2 SENSOR 2 OUTPUT VOLTAGE, V)

It indicates output voltage of HO2S SENSOR 2 installed on exhaust pipe (post-catalyst). It is used to detect catalyst deterioration.

**FUEL SYSTEM B1 (FUEL SYSTEM BANK 1 STATUS)****FUEL SYSTEM B2 (FUEL SYSTEM BANK 2 STATUS)**

Air/fuel ratio feedback loop status displayed as one of the followings.

OPEN: Open loop-has not yet satisfied conditions to go closed loop.

CLOSED: Closed loop-using oxygen sensor(s) as feedback for fuel control.

OPEN-DRIVE COND: Open loop due to driving conditions (Power enrichment, etc.).

OPEN SYS FAULT: Open loop due to detected system fault.

CLOSED-ONE O2S: Closed loop, but fault with at least one oxygen sensor-may be using single oxygen sensor for fuel control.

**CALC LOAD (CALCULATED LOAD VALUE, %)**

Engine load displayed as a percentage of maximum possible load. Value is calculated mathematically using the formula: actual (current) intake air volume ÷ maximum possible intake air volume x 100%.

**TOTAL FUEL TRIM (%)**

The value of total fuel trim is obtained by putting values of short term fuel trim and long term fuel trim together. This value indicates how much correction is necessary to keep the air/fuel mixture stoichiometrical.

**CANIST PRG DUTY (EVAP CANISTER PURGE FLOW DUTY, %)**

This parameter indicates valve ON (valve open) time rate within a certain set cycle of EVAP canister purge valve which controls the amount of EVAP purge.

**VEHICLE SPEED (km/h, MPH)**

It is computed based on pulse signals from vehicle speed sensor in combination meter.

**FUEL CUT (ON/OFF)**

ON: Fuel being cut. (output signal to injector is stopped.)

OFF: Fuel not being cut.

**MAP (MANIFOLD ABSOLUTE PRESSURE, mmHg, kPa)**

This parameter indicates the pressure in the intake manifold absolute pressure.

**EGR VALVE (%)**

This parameter indicates opening rate of EGR valve which controls the amount of EGR flow.

**A/C SWITCH (ON/OFF)**

ON: Command for operation being output from A/C amplifier to compressor.

OFF: Command for operation not being output.

**PSP SWITCH (ON/OFF)**

ON: PSP switch detects P/S operation. (high PS pressure)

OFF: PSP switch not detects P/S operation.

**PNP SIGNAL (TRANSMISSION RANGE SWITCH, P/N or D range)**

Whether the transmission range switch (P/N position switch) at P or N range or at R, D, 2 or L range is displayed. If at P or N range, "P/N range" is displayed and if at R, D, 2 or L range, "D range" is displayed.

**FUEL TANK LEVEL (%)**

This parameter indicates approximate fuel level in the fuel tank. As the detectable range of the fuel level sensor is set as 0 to 100%, however, with some models whose fuel tank capacity is smaller, the indicated fuel level may be only 70% even when the fuel tank is full.

**ELECTRIC LOAD (ON/OFF)**

ON: Small light switch ON or rear window defogger switch ON.

OFF: Small light switch OFF and rear window defogger switch OFF.

**VSS (4-A/T) (km/h, MPH)**

It is computed by using pulse signals from vehicle speed sensor on 4-speed automatic transmission.

**GEAR POSITION (1ST, 2ND, 3RD or 4TH)**

The gear position is determined on the basis of the command state signals generated from PCM to shift solenoids A and B (#1 and #2) and displayed as shown in the table below.

SOLENOID DISPLAY	PCM COMMAND	
	SHIFT SOLENOID-A	SHIFT SOLENOID-B
1ST	ON	OFF
2ND	ON	ON
3RD	OFF	ON
4TH	OFF	OFF

**THROT POS LEVEL (THROTTLE POSITION LEVEL FOR 4-A/T, "0", "1", "2", "3", "4", "5", "6" or "7")**

This parameter indicates which level (zone) the throttle valve opening is in.

The throttle opening is divided into 8 levels (zones) from "0" (about idle position) to "7" (about full open) and signals are assigned to each opening level (zone). PCM controls the automatic gear change of the automatic transmission by using these signals according to the signal from the TP sensor.

**SHIFT SOL #1 CON/MON (SHIFT SOLENOID #1, A COMMAND/MONITOR, ON/OFF)**

CON-ON: ON command being output to shift solenoid #1, A.

CON-OFF: ON command not being output.

MON-ON: Electricity being passed to shift solenoid #1, A.

MON-OFF: Electricity not being passed.

**SHIFT SOL #2 CON/MON (SHIFT SOLENOID #2, B COMMAND/MONITOR, ON/OFF)**

CON-ON: ON command being output to shift solenoid #2, B.

CON-OFF: ON command not being output.

MON-ON: Electricity being passed to shift solenoid #2, B.

MON-OFF: Electricity not being passed.

**TCC SOL CON/MON (TORQUE CONVERTER CLUTCH SOLENOID COMMAND/MONITOR, ON/OFF)**

CON-ON: ON command being output to TCC solenoid.

CON-OFF: ON command not being output.

MON-ON: Electricity being passed to TCC solenoid.

MON-OFF: Electricity not being passed.

**TRANS RANGE (TRANSMISSION RANGE, R, N, D, 2 or L)**

It indicates transmission range according to transmission range switch signal.

**BRAKE SW (BRAKE, STOP LAMP, SWITCH, ON/OFF)**

OFF: Brake pedal is released.

ON: Brake pedal is depressed.

**O/D OFF SW (OVERDRIVE CUT SWITCH, ON/OFF)**

OFF: Overdrive cut switch OFF.

ON: Overdrive cut switch ON.

**MODE SELECT SW (POWER/NORMAL CHANGE SWITCH, POWER/NORMAL)**

POWER: Switch button is at POWER position.

NORMAL: Switch button is at NORMAL position.

**4WD-L SW (4WD-LOW SWITCH, ON/OFF)**

ON: Transfer lever is shifted to 4L position.

OFF: Transfer lever is shifted to 4H or 2H position.

**BLOWER FAN (ON/OFF)**

ON: Blower fan switch ON.

OFF: Blower fan switch OFF.

**A/C CONDENSER FAN (A/C CONDENSER FAN RELAY, ON/OFF)**

ON: A/C condenser fan is operated.

OFF: A/C condenser is not operated.

## ENGINE DIAGNOSIS TABLE

Perform troubleshooting referring to following table when ECM (PCM) has detected no DTC and no abnormality has been found in visual inspection and engine basic inspection previously.

Condition	Possible Cause	Reference Item
<b>Hard starting</b> (Engine cranks OK.)	<b>Engine and emission control system out of order.</b> <ul style="list-style-type: none"> <li>● Faulty idle air control system</li> <li>● Faulty ECT sensor or MAF sensor</li> <li>● Faulty ECM (PCM)</li> </ul> <b>Low compression.</b> <ul style="list-style-type: none"> <li>● Faulty hydraulic valve lash adjuster</li> <li>● Compression leak from valve seat</li> <li>● Sticky valve stem</li> <li>● Weak or damaged valve springs</li> <li>● Compression leak at cylinder head gasket</li> <li>● Sticking or damaged piston ring</li> <li>● Worn piston, ring or cylinder</li> </ul> <b>Others</b> <ul style="list-style-type: none"> <li>● Malfunctioning PCV valve</li> </ul>	DTC P0505 Diag. Flow Table in this section. ECT sensor or MAF sensor in Engine and Emission Control System section. Inspection of ECM (PCM) and its circuit in this section. Compression check in Engine Mechanical section. Valve lash adjuster in Engine Mechanical section. Valves inspection in Engine Mechanical section. Valves inspection in Engine Mechanical section. Valves spring inspection in Engine Mechanical section. Cylinder head inspection in Engine Mechanical section. Piston ring inspection in Engine Mechanical section. Cylinders, pistons and piston rings inspection in Engine Mechanical section. PCV system inspection in Engine and Emission Control System section.
<b>Engine has no power</b>	<b>Engine overheating.</b> <b>Ignition system out of order.</b> <ul style="list-style-type: none"> <li>● Defective spark plug</li> <li>● Faulty ignition coil with ignitor</li> </ul> <b>Fuel system out of order.</b> <ul style="list-style-type: none"> <li>● Fuel pressure out of specification               <ul style="list-style-type: none"> <li>– Dirty fuel filter</li> <li>– Dirty or clogged fuel hose or pipe</li> <li>– Malfunctioning fuel pressure regulator</li> <li>– Malfunctioning fuel pump</li> </ul> </li> </ul> <b>Engine and emission control system out of order.</b> <ul style="list-style-type: none"> <li>● Maladjusted TP sensor installation angle</li> <li>● Faulty EGR system</li> <li>● Faulty injector</li> <li>● Faulty TP sensor, ECT sensor or MAF sensor</li> <li>● Faulty ECM (PCM)</li> </ul> <b>Low compression.</b> <b>Others</b> <ul style="list-style-type: none"> <li>● Dragging brakes</li> <li>● Slipping clutch</li> </ul>	Refer to "Overheating" section.  Spark plugs in Ignition System section. Ignition coil in Ignition System section.  Diag. Flow Table B-3 in this section.  TP sensor in Engine and Emission Control System section. DTC P0400 Diag. Flow Table in this section. Fuel injector in Engine and Emission Control System section. TP sensor, ECT sensor or MAF sensor in Engine and Emission Control System section. Inspection of ECM (PCM) and its circuit in this section. Previously outlined.  Diagnosis in BRAKES section. Diagnosis in Clutch section.

Condition	Possible Cause	Reference Item
<p><b>Improper engine idling or engine fails to idle</b></p>	<p><b>Ignition system out of order.</b></p> <ul style="list-style-type: none"> <li>● Faulty spark plug</li> <li>● Faulty ignition coil with ignitor</li> </ul> <p><b>Fuel system out of order.</b></p> <ul style="list-style-type: none"> <li>● Fuel pressure out of specification</li> </ul> <p><b>Engine overheating.</b></p> <p><b>Engine and emission control system out of order.</b></p> <ul style="list-style-type: none"> <li>● Maladjusted TP sensor installation angle if adjustable</li> <li>● Faulty idle air control system</li> <li>● Faulty evaporative emission control system</li> <li>● Faulty EGR system</li> <li>● Faulty injector</li> <li>● Faulty ECT sensor, TP sensor or MAF sensor</li> <li>● Faulty ECM (PCM)</li> </ul> <p><b>Low compression</b></p> <p><b>Others</b></p> <ul style="list-style-type: none"> <li>● Malfunctioning PCV valve</li> </ul>	<p>Spark plugs in Ignition System section.</p> <p>Ignition coil in Ignition System section.</p> <p>Diag. Flow Table B-3 in this section. Refer to “Overheating” section.</p> <p>TP sensor in Engine and Emission Control System section.</p> <p>DTC P0505 Diag. Flow Table in this section.</p> <p>EVAP control system in Engine and Emission Control System section.</p> <p>DTC P0400 Diag. Flow Table in this section.</p> <p>Fuel injection in Engine and Emission Control System section.</p> <p>ECT sensor, TP sensor or MAF sensor in Engine and Emission Control System section.</p> <p>Inspection of ECM (PCM) and its circuit in this section.</p> <p>Previously outlined.</p> <p>PCV system inspection in Engine and Emission Control System section.</p>
<p><b>Engine hesitates</b> (Momentary lack of response as the accelerator is depressed. Can occur at all vehicle speeds. Usually most severe when first trying to make the vehicle move, as from a stop sign.)</p>	<p><b>Ignition System out of order.</b></p> <ul style="list-style-type: none"> <li>● Spark plug faulty or plug gap as out of adjustment</li> </ul> <p><b>Fuel system out of order.</b></p> <ul style="list-style-type: none"> <li>● Fuel pressure out of specification <ul style="list-style-type: none"> <li>– Clogged fuel filter</li> <li>– Faulty fuel pressure regulator</li> </ul> </li> <li>● Clogged fuel filter, hose or pipe</li> </ul> <p><b>Engine overheating</b></p> <p><b>Engine and emission control system out of order.</b></p> <ul style="list-style-type: none"> <li>● Faulty EGR system</li> <li>● Faulty injector</li> <li>● Faulty TP sensor, ECT sensor or MAF sensor</li> <li>● Faulty ECM (PCM)</li> </ul> <p><b>Low compression</b></p>	<p>Spark plugs in Ignition System section.</p> <p>Diag. Flow Table B-3 in this section.</p> <p>Refer to “Overheating” section.</p> <p>DTC P0440 Diag. Flow Table in this section.</p> <p>Fuel injector in Engine and Emission Control System section.</p> <p>TP sensor, ECT sensor or MAF sensor in Engine and Emission Control System section.</p> <p>Inspection of ECM (PCM) and its circuit in this section.</p> <p>Previously outlined.</p>

Condition	Possible Cause	Reference Item
<p><b>Surges</b> (Engine power variation under steady throttle or cruise. Feels like the vehicle speeds up and down with no change in the accelerator pedal.)</p>	<p><b>Ignition system out of order.</b></p> <ul style="list-style-type: none"> <li>● Defective spark plug (excess carbon deposits, improper gap, and burned electrodes, etc.)</li> </ul> <p><b>Fuel system out of order.</b></p> <ul style="list-style-type: none"> <li>● Variable fuel pressure <ul style="list-style-type: none"> <li>– Clogged fuel filter</li> <li>– Kinky or damaged fuel hose and line</li> <li>– Faulty fuel pressure regulator</li> </ul> </li> </ul> <p><b>Engine and emission control system out of order.</b></p> <ul style="list-style-type: none"> <li>● Faulty EGR system</li> <li>● Faulty MAF sensor</li> <li>● Faulty injector</li> <li>● Faulty ECM (PCM)</li> </ul>	<p>Spark plugs in Ignition System section.</p> <p>Diag. Flow Table B-3 in this section.</p> <p>DTC P0400 Diag. Flow Table in this section.</p> <p>MAF sensor in Engine and Emission Control System section.</p> <p>Fuel injector in Engine and Emission Control System section.</p> <p>Inspection of ECM (PCM) and its circuit in this section.</p>
<p><b>Excessive detonation</b> (The engine makes sharp metallic knocks that change with throttle opening. Sounds like pop corn popping.)</p>	<p><b>Engine overheating</b></p> <p><b>Ignition system out of order.</b></p> <ul style="list-style-type: none"> <li>● Faulty spark plug</li> <li>● Improper ignition timing</li> </ul> <p><b>Fuel system out of order.</b></p> <ul style="list-style-type: none"> <li>● Clogged fuel filter and fuel lines</li> </ul> <p><b>Engine and emission control system out of order.</b></p> <ul style="list-style-type: none"> <li>● Faulty EGR system</li> <li>● Faulty ECT sensor or MAF sensor</li> <li>● Faulty injector</li> <li>● Faulty ECM (PCM)</li> </ul> <p><b>Others</b></p> <ul style="list-style-type: none"> <li>● Excessive combustion chamber deposits</li> </ul>	<p>Refer to “Overheating” section.</p> <p>Spark plugs in Ignition System section.</p> <p>Ignition timing in Ignition System section.</p> <p>Fuel pressure check in Engine and Emission Control System section.</p> <p>DTC P0400 Diag. Flow Table in this section.</p> <p>ECT sensor or MAF sensor in Engine and Emission Control System section.</p> <p>Fuel injector in Engine and Emission Control System section.</p> <p>Inspection of ECM (PCM) and its circuit in this section.</p> <p>Piston and cylinder head cleaning in Engine Mechanical section.</p>

Condition	Possible Cause	Reference Item
<b>Overheating</b>	<ul style="list-style-type: none"> <li>● Inoperative thermostat</li> <li>● Poor water pump performance</li> <li>● Clogged or leaky radiator</li> <li>● Improper engine oil grade</li> <li>● Clogged oil filter or oil strainer</li> <li>● Poor oil pump performance</li> <li>● Dragging brakes</li> <li>● Slipping clutch</li> <li>● Blown cylinder head gasket</li> </ul>	<p>Thermostat in Engine Cooling section.</p> <p>Water pump in Engine Cooling section.</p> <p>Radiator in Engine Cooling section.</p> <p>Engine oil and oil filter change in Maintenance and Lubrication section.</p> <p>Oil pressure check in Engine Mechanical section.</p> <p>Oil pressure check in Engine Mechanical section.</p> <p>Diagnosis in BRAKES section.</p> <p>Diagnosis in Clutch section.</p> <p>Cylinder head inspection in Engine Mechanical section.</p>
<b>Poor gasoline mileage</b>	<p><b>Ignition system out of order.</b></p> <ul style="list-style-type: none"> <li>● Faulty spark plug (improper gap, heavy deposits, and burned electrodes, etc.)</li> </ul> <p><b>Engine and emission control system out of order.</b></p> <ul style="list-style-type: none"> <li>● Fuel pressure out of specification</li> <li>● Faulty TP sensor, ECT sensor or MAF sensor</li> <li>● Faulty EGR system</li> <li>● Faulty injector</li> <li>● Faulty ECM (PCM)</li> </ul> <p><b>Low compression</b></p> <p><b>Others</b></p> <ul style="list-style-type: none"> <li>● Poor valve seating</li> <li>● Dragging brakes</li> <li>● Slipping clutch</li> <li>● Thermostat out of order</li> <li>● Improper tire pressure</li> </ul>	<p>Spark plugs in Ignition System section.</p> <p>Diag. Flow Table B-3 in this section.</p> <p>TP sensor, ECT sensor or MAF sensor in Engine and Emission Control System section.</p> <p>DTC P0400 Diag. Flow Table in this section.</p> <p>Fuel injector in Engine and Emission Control System section.</p> <p>Inspection of ECM (PCM) and its circuit in this section.</p> <p>Previously outlined.</p> <p>Valves inspection in Engine Mechanical section.</p> <p>Diagnosis in Brake section.</p> <p>Diagnosis in Clutch section.</p> <p>Thermostat in Engine Cooling section.</p>
<b>Excessive engine oil consumption</b>	<p><b>Oil entering combustion chamber</b></p> <ul style="list-style-type: none"> <li>● Sticky piston ring</li> <li>● Worn piston and cylinder</li> <li>● Worn piston ring groove and ring</li> <li>● Improper location of piston ring gap</li> <li>● Worn or damaged valve stem seal</li> <li>● Worn valve stem</li> </ul>	<p>Piston cleaning in Engine Mechanical section.</p> <p>Cylinders, pistons and piston rings inspection in Engine Mechanical section.</p> <p>Pistons and piston rings inspection in Engine Mechanical section.</p> <p>Pistons installation in Engine Mechanical section.</p> <p>Valves and cylinder head in Engine Mechanical section.</p> <p>Valves inspection in Engine Mechanical section.</p>

Condition	Possible Cause	Reference Item
<p><b>Low oil pressure</b></p>	<ul style="list-style-type: none"> <li>● Improper oil viscosity</li> <li>● Malfunctioning oil pressure switch</li> <li>● Clogged oil strainer</li> <li>● Functional deterioration of oil pump</li> <li>● Worn oil pump relief valve</li> <li>● Excessive clearance in various sliding parts</li> </ul>	<p>Engine oil and oil filter change in Maintenance and Lubrication section.</p> <p>Oil pressure switch inspection in BODY ELECTRICAL SYSTEM section.</p> <p>Oil pan and oil pump strainer cleaning in Engine Mechanical section.</p> <p>Oil pump in Engine Mechanical section.</p> <p>Oil pump in Engine Mechanical section.</p>
<p><b>Engine noise</b> Note: Before checking the mechanical noise, make sure that:</p> <ul style="list-style-type: none"> <li>● Ignition timing is properly adjusted.</li> <li>● Specified spark plug is used.</li> <li>● Specified fuel is used.</li> </ul>	<p><b>Valve noise</b></p> <ul style="list-style-type: none"> <li>● Faulty hydraulic valve lash adjuster</li> <li>● Worn valve stem and guide</li> <li>● Weak or broken valve spring</li> <li>● Warped or bent valve</li> <li>● Loose camshaft housing bolts</li> </ul> <p><b>Piston, ring and cylinder noise</b></p> <ul style="list-style-type: none"> <li>● Worn piston, ring and cylinder bore</li> </ul> <p><b>Connecting rod noise</b></p> <ul style="list-style-type: none"> <li>● Worn crankpin bearing</li> <li>● Worn crankpin</li> <li>● Loose connecting rod nuts</li> <li>● Low oil pressure</li> </ul> <p><b>Crankshaft noise</b></p> <ul style="list-style-type: none"> <li>● Low oil pressure</li> <li>● Worn crankshaft journal bearing</li> <li>● Worn crankshaft journal</li> <li>● Loose lower crankcase (bearing cap) bolts</li> <li>● Excessive crankshaft thrust play</li> </ul>	<p>Hydraulic valve lash adjuster in Engine Mechanical section.</p> <p>Valves inspection in Engine Mechanical section.</p> <p>Valve springs inspection in Engine Mechanical section.</p> <p>Valves inspection in Engine Mechanical section.</p> <p>Camshafts in Engine Mechanical section.</p> <p>Pistons and cylinders inspection in Engine Mechanical section.</p> <p>Crankpin and connecting rod bearing inspection in Engine Mechanical section.</p> <p>Crankpin and connecting rod bearing inspection in Engine Mechanical section.</p> <p>Connecting rod installation in Engine Mechanical section.</p> <p>Previously outlined.</p> <p>Previously outlined.</p> <p>Crankshaft and bearing inspection in Engine Mechanical section.</p> <p>Crankshaft and bearing inspection in Engine Mechanical section.</p> <p>Crankshaft installation in Engine Mechanical section.</p> <p>Crankshaft inspection in Engine Mechanical section.</p>

## ECM (PCM) SUBSTITUTION

When substituting a known-good ECM (PCM), check for following conditions. Neglecting this check may cause damage to known-good ECM (PCM).

- Resistance value of all relays, actuators is as specified respectively.
- MAF sensor, MAP sensor, TP sensor and fuel tank pressure sensor are in good condition and none of power circuits of these sensors is shorted to ground.

## INSPECTION OF ECM (PCM) AND ITS CIRCUITS

ECM (PCM) and its circuits can be checked at ECM (PCM) wiring couplers by measuring voltage and resistance.

**CAUTION:**

**ECM (PCM) cannot be checked by itself. It is strictly prohibited to connect voltmeter or ohmmeter to ECM (PCM) with couplers disconnected from it.**

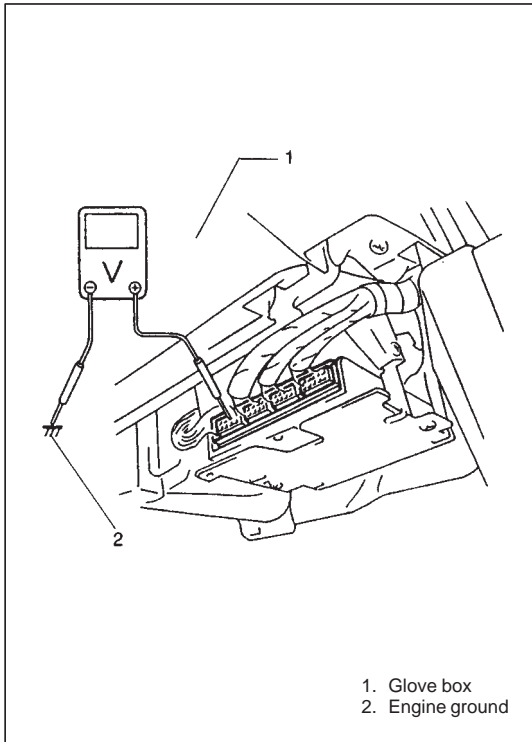

1. Glove box  
2. Engine ground

### VOLTAGE CHECK

- 1) Remove ECM (PCM) cover from bracket referring to “ECM (PCM) REMOVAL”.
- 2) Check voltage at each terminal of couplers connected.

**NOTE:**

**As each terminal voltage is affected by the battery voltage, confirm that it is 11 V or more when ignition switch is ON.**

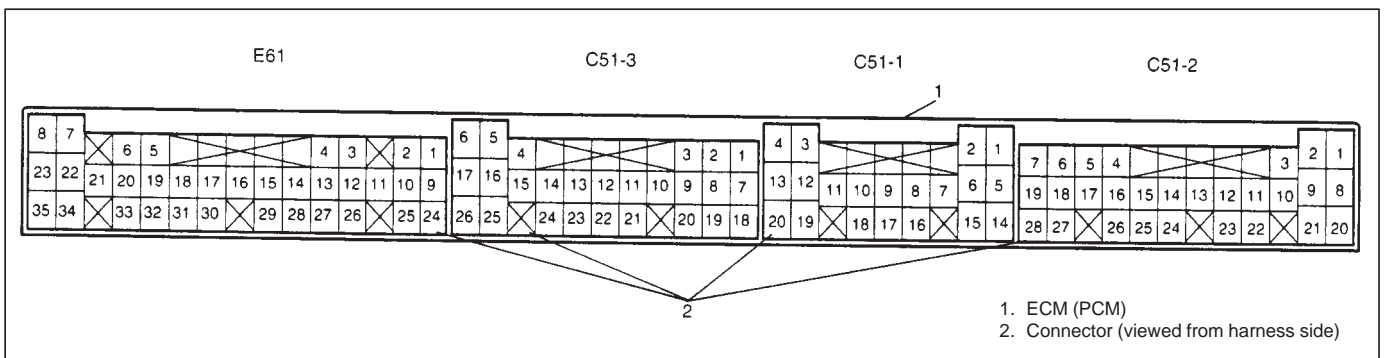

1. ECM (PCM)  
2. Connector (viewed from harness side)

TERMINAL	CIRCUIT	NORMAL VOLTAGE	CONDITION
E61-1	Fuel pump relay	0 – 2.5 V	For 3 sec. after ignition switch ON or while engine running.
		10 – 14 V	After 3 sec. from ignition switch ON with engine stopped.
E61-2	_____	_____	_____
E61-3	_____	_____	_____
E61-4	Tachometer	0 – 0.8 V	Ignition switch ON, engine stops.
E61-5	A/C condenser fan motor relay (if equipped)	10 – 14 V	Ignition switch ON.
		0 – 2.5 V	A/C condenser fan motor ON.
E61-6	_____	_____	_____
E61-7	"O/D OFF" lamp (A/T VEHICLE)	0 – 2.5 V	For 4 sec. after ignition switch ON, overdrive cut switch ON.
		10 – 14 V	After 4 sec. from ignition switch ON and overdrive cut switch OFF.
E61-8	Main relay	10 – 14 V	Ignition switch OFF.
		0 – 2 V	Ignition switch ON.
E61-9	Power/Normal change switch (A/T VEHICLE)	0 – 1 V	For 4 sec. after ignition switch ON, P/N change switch in POWER mode
		10 – 14 V	Ignition switch ON, P/N change switch: NORMAL mode
E61-10	"POWER" lamp (A/T VEHICLE)	0 – 2.5 V	Ignition switch ON, P/N change switch: POWER mode
		10 – 14 V	Ignition switch ON, P/N change switch: NORMAL mode
E61-11	_____	_____	_____
E61-12	Fuel level sensor	0.7 – 5.5 V (Full) (Empty)	Ignition switch ON.
E61-13	Heater blower switch	10 – 14 V	Ignition switch ON, heater blower switch OFF.
		0 – 2.5 V	Ignition switch ON, heater blower switch ON.
E61-14	Overdrive cut switch (A/T VEHICLE)	10 – 14 V	Ignition switch ON, overdrive cut switch OFF.
		0 – 1 V	Ignition switch ON, overdrive cut switch ON.
E61-15	Rear defogger switch (if equipped)	0 – 1 V	Rear defogger switch OFF.
		10 – 14 V	Ignition switch ON. Rear defogger switch ON.
E61-16	Test switch terminal (vehicle with monitor connector)	10 – 14 V	Ignition switch ON.
E61-17	Output duty select switch terminal (vehicle with monitor connector)	10 – 14 V	Ignition switch ON.
E61-18	ABS control module (if equipped)	10 – 14 V	Ignition switch ON.
E61-19	CO adjusting resistor (if equipped)	_____	_____
E61-20	_____	_____	_____

**6-1-40 ENGINE (H25 ENGINE)**

TERMINAL	CIRCUIT	NORMAL VOLTAGE	CONDITION
E61-21, 22	—	—	—
E61-23	Immobilizer indicator lamp (vehicle without monitor connector)	0 – 1 V	Ignition switch ON
		10 – 14 V	Engine running
	Duty output terminal (vehicle with monitor connector)	0 – 1 V	Ignition switch ON
E61-24	Data link connector (5 V)	4 – 6 V	Ignition switch ON
E61-25	Data link connector (12 V)	10 – 14 V	Ignition switch ON
E61-26	Power steering pressure switch	10 – 14 V	Ignition switch ON
		0 – 1 V	With engine running at idle speed, turning steering wheel to the right or left as far as it stops
E61-27	A/C cut signal (if equipped)	0 – 1 V	A/C is not operating
		10 – 14 V	A/C is operating
E61-28	A/C signal (if equipped)	10 – 14 V	Ignition switch ON, A/C switch or heater blower switch OFF
		0 – 1.5 V	Ignition switch ON, A/C switch ON and heater blower switch ON
E61-29	Lighting switch	0 – 1 V	Ignition switch ON, lighting switch OFF
		10 – 14 V	Ignition switch ON, lighting switch ON
E61-30	Diag. switch terminal (vehicle with monitor connector)	10 – 14 V	Ignition switch ON
E61-31	Stop lamp switch (A/T VEHICLE)	0 – 1 V	Brake pedal released (switch OFF), Ignition switch ON
		10 – 14 V	Brake pedal depressed (switch ON), Ignition switch ON
E61-32	CO adjusting resistor ground (if equipped)	—	—
E61-33	Power source for CO adjusting resistor (if equipped)	4.75 – 5.25 V	Ignition switch ON
E61-34	Malfunction indicator lamp	0 – 2.5 V	Ignition switch ON, engine stops
		10 – 14 V	Engine running
E61-35	Power source for back up	10 – 14 V	Ignition switch ON and OFF
C51-3-1	Vehicle speed sensor	Deflects between 0 and over 4 V	Ignition switch ON, Rear right tire turned slowly with rear left tire locked
C51-3-2	Crankshaft position (CKP) sensor (if equipped)	—	—
C51-3-3	Crankshaft position (CKP) sensor (if equipped)	—	—
C51-3-4	Heated oxygen sensor (Bank 1 – Sensor 1) (if equipped)	Deflects between over and under 0.5 V	While engine running at 2,000 r/min. for 1 min. or longer after warmed up
C51-3-5	Heater of HO2S (Bank 2 – Sensor 1) (if equipped)	10 – 14 V	Ignition switch ON
		Deflects between 0 – 1 V and 10 – 14 V	At specified idle speed after engine warmed up
C51-3-6	Heater of HO2S (Bank 1 – Sensor 1) (if equipped)	10 – 14 V	Ignition switch ON
		Deflects between 0 – 1 V and 10 – 14 V	At specified idle speed after engine warmed up
C51-3-7	—	—	—
C51-3-8	Intake air temp. sensor	2.2 – 3.0 V	Ignition switch ON, Sensor ambient temp.: 20°C, 68°F

TERMINAL	CIRCUIT	NORMAL VOLTAGE	CONDITION
C51-3-9	Camshaft position sensor (POS)	Deflects between 0 – 1 V and 4 – 6 V	Ignition switch ON, crankshaft turned slowly.
C51-3-10	Camshaft position sensor (REF)	Deflects between 0 – 1 V and 4 – 6 V	Ignition switch ON, camshaft turned slowly.
C51-3-11	Power source for TP sensor and MAP sensor	4.75 – 5.25 V	Ignition switch ON.
C51-3-12	Throttle position sensor	0.35 – 0.65 V	Ignition switch ON, throttle valve at idle position.
		3.5 – 4.5 V	Ignition switch ON, throttle valve at full open position.
C51-3-13	Manifold absolute pressure sensor	3.3 – 4.3 V	Ignition switch ON.
C51-3-14	Heated oxygen sensor (Bank 1 – Sensor 2) (if equipped)	—	—
C51-3-15	Heated oxygen sensor (Bank 2 – Sensor 1) (if equipped)	Deflect between over and under 0.5 V	While engine running at 2000 r/min. for 1 min. or longer after warmed up.
C51-3-16	Heater of HO2S (Bank 2 – Sensor 2) (if equipped)	10 – 14 V	Ignition switch ON.
		Deflect between 0 – 1 V and 10 – 14 V	At specified idle speed after engine warmed up.
C51-3-17	Heater of HO2S (Bank 1 – Sensor 2) (if equipped)	10 – 14 V	Ignition switch ON.
		Deflect between 0 – 1 V and 10 – 14 V	At specified idle speed after engine warmed up.
C51-3-18	—	—	—
C51-3-19	—	—	—
C51-3-20, 21	Ground	—	—
C51-3-22	Engine coolant temp. sensor	0.5 – 0.9 V	Ignition switch ON, Engine coolant temp.: 80°C, 176°F
C51-3-23	Mass air flow sensor	0.5 – 1.0 V	Ignition switch ON and engine stops.
		1.5 – 1.8 V	With engine running at idle speed.
C51-3-24	Heated oxygen sensor (Bank 2 – Sensor 2) (if equipped)	—	—
C51-3-25, 26	Ground	—	—
C51-1-1	Shift solenoid B (A/T VEHICLE)	0 – 1 V	Ignition switch ON.
C51-1-2	TCC solenoid (A/T VEHICLE)	0 – 1 V	Ignition switch ON.
C51-1-3	Transmission range switch “R” (A/T VEHICLE)	10 – 14 V	Ignition switch ON, selector lever: “R” range
		0 – 1 V	Ignition switch ON, selector lever: Other than “R” range
C51-1-4	Transmission range switch “P” (A/T VEHICLE)	10 – 14 V	Ignition switch ON, selector lever: “P” range
		0 – 1 V	Ignition switch ON, selector lever: Other than “P” range
C51-1-5	4WD low switch (if equipped) (A/T VEHICLE)	0 – 1 V	Ignition switch ON, transfer lever: 4WD low range
		10 – 14 V	Ignition switch ON, transfer lever: 4H or 2H range

**6-1-42 ENGINE (H25 ENGINE)**

TERMINAL	CIRCUIT	NORMAL VOLTAGE	CONDITION
C51-1-6	Shift solenoid A (A/T VEHICLE)	10 – 14 V	Ignition switch ON
C51-1-7	4WD lamp (if equipped)	10 – 14 V	Ignition switch ON, Transfer lever: N or 2H range
		0 – 1 V	Ignition switch ON, Transfer lever: 4L or 4H range
C51-1-8	A/T input speed sensor (A/T VEHICLE)	—	—
C51-1-9	A/T vehicle (output) speed sensor (A/T VEHICLE)	—	—
C51-1-10	A/T vehicle (output) speed sensor (A/T VEHICLE)	—	—
C51-1-11	4WD switch (if equipped)	10 – 14 V	Ignition switch ON, Transfer lever: N or 2H range
		0 – 1 V	Ignition switch ON, Transfer lever: 4L or 4H range
C51-1-12	Transmission range switch “D” (A/T VEHICLE)	10 – 14 V	Ignition switch ON, selector lever: “D” range
		0 – 1 V	Ignition switch ON, selector lever: Other than “D” range
C51-1-13	Transmission range switch “N”	10 – 14 V	Ignition switch ON, selector lever: “N” range
		0 – 1 V	Ignition switch ON, selector lever: Other than “N” range
C51-1-14	Shield wire ground for A/T input speed sensor and A/T vehicle (output) speed sensor (A/T VEHICLE)	—	—
C51-1-15	4WD actuator (if equipped)	10 – 14 V	Ignition switch ON, Transfer lever: 4L or 4H range
		0 – 1 V	Ignition switch ON, Transfer lever: N or 2H range
C51-1-16	A/T input speed sensor (A/T VEHICLE)	—	—
C51-1-17	—	—	—
C51-1-18	4WD pressure switch (if equipped)	10 – 14 V	Ignition switch ON, Transfer lever: 4L or 4H range
		0 V	Ignition switch ON, Transfer lever: N or 2H range
C51-1-19	Transmission range switch “L” (A/T VEHICLE)	10 – 14 V	Ignition switch ON, selector lever: “L” range
		0 – 1 V	Ignition switch ON, selector lever: Other than “L” range
C51-1-20	Transmission range switch “2” (A/T VEHICLE)	10 – 14 V	Ignition switch ON, selector lever: “2” range
		0 – 1 V	Ignition switch ON, selector lever: Other than “2” range
C51-2-1	EVAP canister purge valve	10 – 14 V	Ignition switch ON
C51-2-2	Ground	—	—
C51-2-3	Ignition switch	10 – 14 V	Ignition switch ON
C51-2-4	EGR valve (stepper motor coil 2) (if equipped)	10 – 14 V	Ignition switch ON
C51-2-5	EGR valve (stepper motor coil 1) (if equipped)	0 – 1 V	
C51-2-6	Fuel injector No.2	10 – 14 V	Ignition switch ON
C51-2-7	Fuel injector No.1		
C51-2-8, 9	Ground	—	—
	Ground	—	—
C51-2-10	Ignition coil assembly for No.4	—	—
C51-2-11	Ignition coil assembly for No.3	—	—
C51-2-12	Ignition coil assembly for No.2	—	—
C51-2-13	Ignition coil assembly for No.1	—	—

TERMINAL	CIRCUIT	NORMAL VOLTAGE	CONDITION
C51-2-14	IAC valve (stepper motor coil 2)	———	———
C51-2-15	IAC valve (stepper motor coil 1)	———	———
C51-2-16	EGR valve (stepper motor coil 4) (if equipped)	0 – 1 V	Ignition switch ON
C51-2-17	EGR valve (stepper motor coil 3) (if equipped)	10 – 14 V	
C51-2-18	Fuel injector No.4	10 – 14 V	Ignition switch ON
C51-2-19	Fuel injector No.3		
C51-2-20, 21	Power source	10 – 14 V	Ignition switch ON
C51-2-22	Ignition coil assembly for No.6	———	———
C51-2-23	Ignition coil assembly for No.5	———	———
C51-2-24	IAC valve (stepper motor coil 4)	———	———
C51-2-25	IAC valve (stepper motor coil 3)	———	———
C51-2-26	Engine start signal	6 – 14 V	While engine cranking
		0 – 1 V	Other than above
C51-2-27	Fuel injector No.6	10 – 14 V	Ignition switch ON
C51-2-28	Fuel injector No.5		

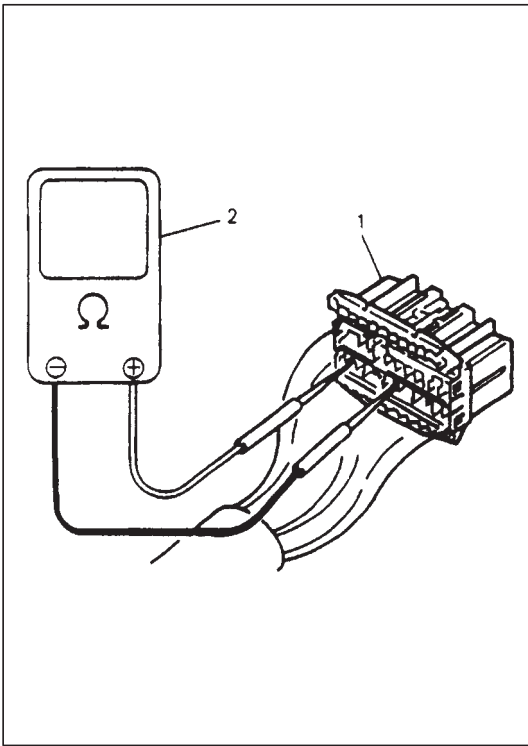

### RESISTANCE CHECK

- 1) Disconnect ECM couplers (1) from ECM with ignition switch OFF.

**CAUTION:**

**Never touch terminals of ECM itself or connect voltmeter or ohmmeter (2).**

- 2) Check resistance between each pair of terminals of disconnected couplers as listed in following table.

**CAUTION:**

- Be sure to connect ohmmeter probe from wire harness side of coupler.
- Be sure to turn OFF ignition switch for this check.
- Resistance in table represents that when parts temperature is 20°C (68°F).

TERMINAL	CIRCUIT	STANDARD RESISTANCE	CONDITION
E61-1 – C51-2-3	Fuel pump relay	70 – 110 Ω	—
E61-5 – C51-2-3	A/C condenser fan relay	75 – 110 Ω	Battery disconnected and ignition switch ON.
E61-8 – E61-35	Main relay	70 – 110 Ω	—
E61-12 – Body ground	Fuel level sensor	117.5 – 122.5 Ω	Fuel level is Empty.
		1.5 – 4.5 Ω	Fuel level is Full.
C51-3-2 – C51-3-3	CKP sensor	485 – 655 Ω	—
C51-3-8 – C51-3-20	IAT sensor	2.09 – 2.81 kΩ	—
C51-3-22 – C51-3-21	ECT sensor	303 – 326 Ω	Engine coolant temp.: 80°C (176°F)

TERMINAL	CIRCUIT	STANDARD RESISTANCE	CONDITION
C51-1-1 – Body ground	Shift solenoid-B	11 – 15 Ω	—
C51-1-2 – Body ground	TCC solenoid		
C51-1-6 – Body ground	Shift solenoid-A		
C51-1-8 – C51-1-16	A/T input speed sensor	560 – 680 Ω	—
C51-1-9 – C51-1-10	A/T output speed sensor	369 – 451 Ω	—
C51-2-1 – C51-2-20	EVAP canister purge valve	28 – 36 Ω	—
C51-2-5 – C51-2-20	EGR valve (stepper motor coil 1)	20 – 24 Ω	—
C51-2-4 – C51-2-20	EGR valve (stepper motor coil 2)		
C51-2-17 – C51-2-20	EGR valve (stepper motor coil 3)		
C51-2-16 – C51-2-20	EGR valve (stepper motor coil 4)		
C51-2-7 – C51-2-20	Fuel injector No.1	10 – 14 Ω	—
C51-2-6 – C51-2-20	Fuel injector No.2		
C51-2-19 – C51-2-20	Fuel injector No.3		
C51-2-18 – C51-2-20	Fuel injector No.4		
C51-2-28 – C51-2-20	Fuel injector No.5		
C51-2-27 – C51-2-20	Fuel injector No.6		
C51-2-15 – C51-2-20	IAC valve (stepper motor coil 1)	21 – 23 Ω	—
C51-2-14 – C51-2-20	IAC valve (stepper motor coil 2)		
C51-2-25 – C51-2-20	IAC valve (stepper motor coil 3)		
C51-2-24 – C51-2-20	IAC valve (stepper motor coil 4)		

**TABLE A-1 MALFUNCTION INDICATOR LAMP CIRCUIT CHECK**

**MIL DOES NOT COME ON OR MIL DIMMS AT IGNITION SWITCH ON LEAVING ENGINE OFF**

**WIRING DIAGRAM**

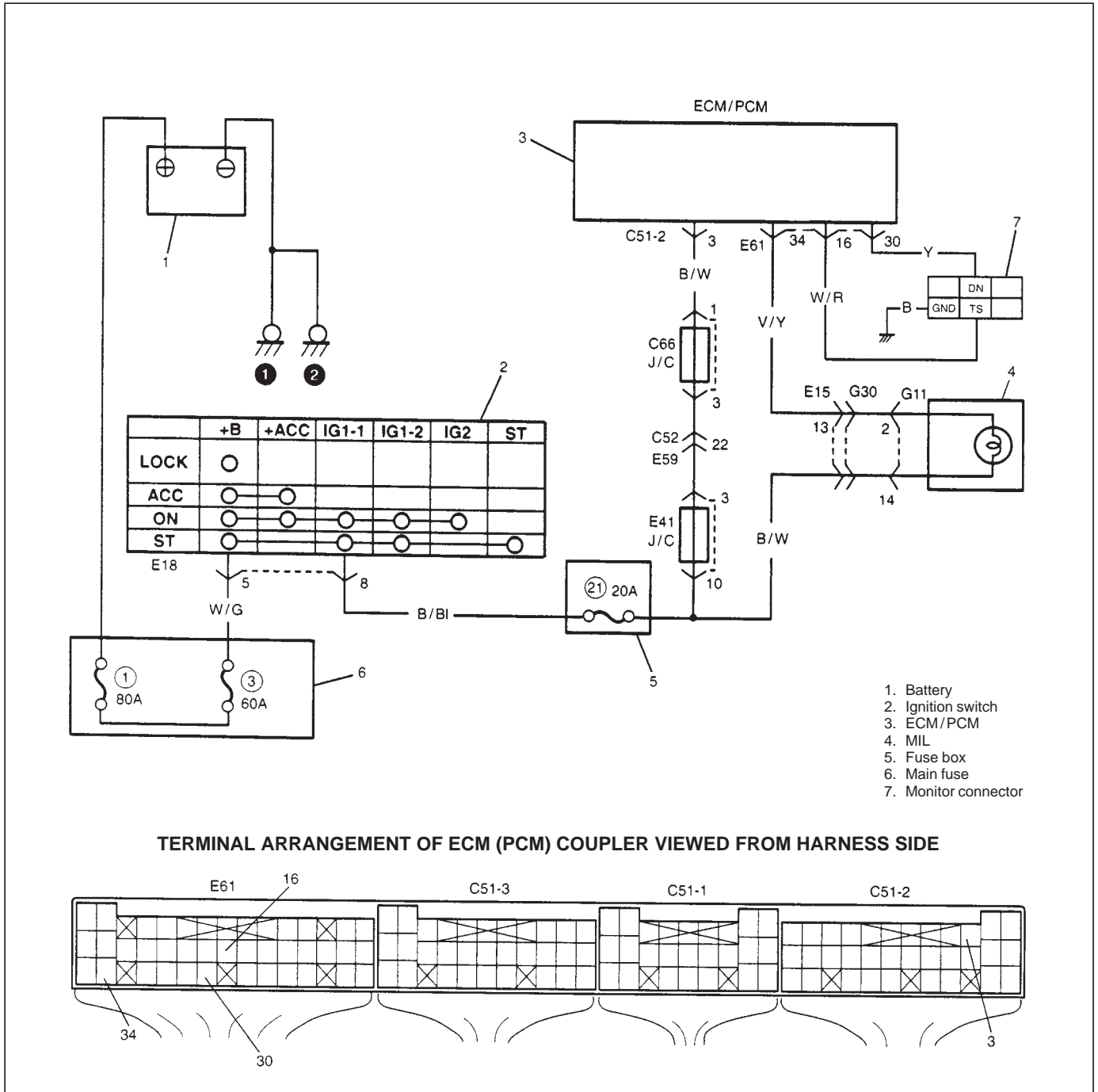

- 1. Battery
- 2. Ignition switch
- 3. ECM/PCM
- 4. MIL
- 5. Fuse box
- 6. Main fuse
- 7. Monitor connector

**CIRCUIT DESCRIPTION**

When the ignition switch is turned ON, ignition switch signal is sent to ECM. The ECM causes the main relay to turn ON. Then, ECM (PCM) being supplied with the main power, turns ON the malfunction indicator lamp. When the engine starts to run and no malfunction is detected in the system, MIL goes OFF but if a malfunction was or is detected, MIL remains ON when the engine is running.

**TROUBLESHOOTING**

STEP	ACTION	YES	NO
1	Test Switch Terminal check (vehicle with monitor connector): (1) Check test switch terminal of monitor connector for being grounded. (2) With ignition switch ON leaving engine OFF, measure voltage between E61-16 and ground. Check the voltage for 10 – 14 V. Are they in good condition?	Go to Step 2.	Test switch terminal circuit is shorted to ground. Repair or correct.
2	Ignition Switch Signal check: (1) Remove ECM (PCM) cover. (2) With ignition switch ON leaving engine OFF, check voltage between C51-2-3 and ground. Is voltage 10 – 14 V?	Go to Step 3.	Fuse (1, 3 or 21) blown. Faulty circuit (Battery – C51-2-3).
3	MIL Bulb and Circuit check: (1) Using service wire, ground E61-34 terminal. Does MIL turn ON at ignition switch ON?	Go to TABLE A-3 “ECM (PCM) POWER AND GROUND CIRCUIT CHECK” in this section.	Faulty circuit (Fuse 21 – E61-34). MIL bulb burned out.

**TABLE A-2 MALFUNCTION INDICATOR LAMP CIRCUIT CHECK****MIL REMAINS ON AFTER ENGINE STARTS****WIRING DIAGRAM/CIRCUIT DESCRIPTION**

Refer to TABLE A-1.

**TROUBLESHOOTING**

STEP	ACTION	YES	NO
1	DTC check: (1) With ignition switch OFF, install scan tool. (2) Start engine and check DTC. Is there any DTC(s)?	Go to Step 2 of "ENGINE DIAG. FLOW TABLE" in this section.	Go to Step 2.
2	MIL Circuit check: (1) With ignition switch OFF, disconnect couplers from ECM (PCM). Does MIL turn ON at ignition switch ON?	"V/Y" wire shorted to ground circuit.	Substitute a known- good ECM (PCM) and recheck.

**TABLE A-3 MALFUNCTION INDICATOR LAMP CHECK****MIL FLASHES AT IGNITION SWITCH ON (vehicle with monitor connector)****WIRING DIAGRAM/CIRCUIT DESCRIPTION**

Refer to TABLE A-1.

**TROUBLESHOOTING**

STEP	ACTION	YES	NO
1	MIL Flashing Pattern check: 1) Turn ignition switch ON. Does lamp flashing pattern indicate diagnostic trouble code?	Go to Step 2.	Go to "Diagnosis" in Section 8G.
2	Diag. Switch Circuit check: Is diag. switch terminal connected to ground via service wire?	System is in good condition.	"Y" circuit shorted to ground. If circuit is OK substitute a known-good ECM (PCM) and recheck.

**TABLE A-4 MALFUNCTION INDICATOR LAMP CHECK**

**MIL DOES NOT FLASH OR JUST REMAINS ON EVEN WITH GROUNDING DIAGNOSIS SWITCH TERMINAL (vehicle with monitor connector)**

**WIRING DIAGRAM/CIRCUIT DESCRIPTION**

Refer to TABLE A-1.

**TROUBLESHOOTING**

STEP	ACTION	YES	NO
1	MIL Circuit check: 1) Turn ignition switch OFF and disconnect connectors from ECM (PCM). Does MIL turn ON at ignition switch ON?	"V/Y" circuit shorted to ground.	Go to Step 2.
2	ECM (PCM) Connection check: 1) Turn ignition switch OFF. Is connector (E61-30 connection) connected to ECM (PCM) properly?	Go to Step 3.	Poor connector connection.
3	Diag. switch Terminal Circuit check: 1) Connect connectors to ECM (PCM). 2) Using service wire, ground E61-30 terminal with connectors connected to ECM (PCM). 3) Turn ignition switch ON. Does MIL flash?	"Y" or "B" circuit open.	Substitute a known-good ECM (PCM) and recheck.

**TABLE A-5 ECM (PCM) POWER AND GROUND CIRCUIT CHECK**

**MIL DOES NOT LIGHT AT IGNITION SWITCH ON AND ENGINE DOES NOT START THOUGH IT IS CRANKED UP.**

**WIRING DIAGRAM**

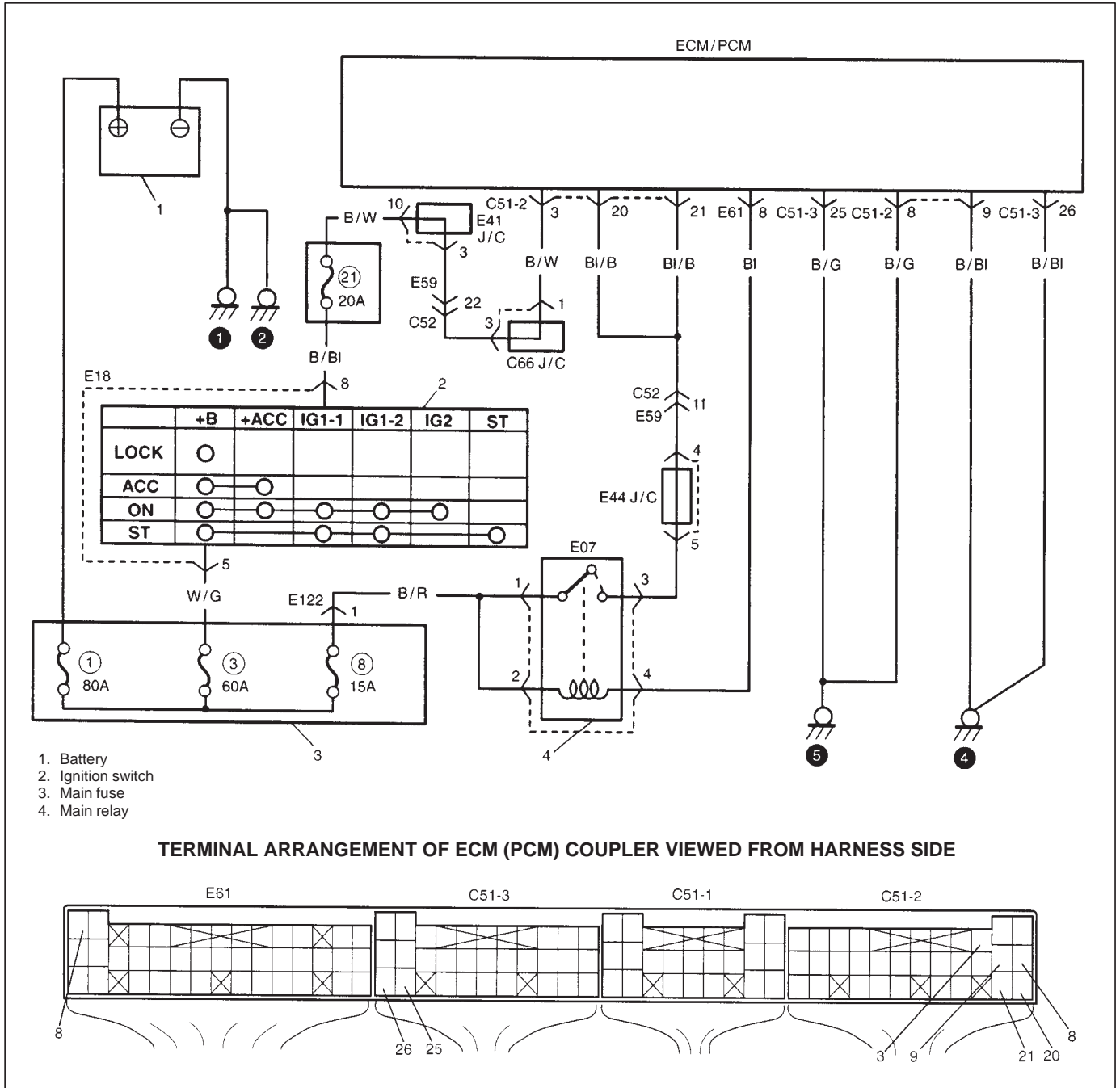

**CIRCUIT DESCRIPTION**

When the ignition switch is turned ON, the main relay turns ON and the main power is supplied to ECM (PCM).

**TROUBLESHOOTING**

STEP	ACTION	YES	NO
1	Main Relay Operating Sound check: Is operating sound of main relay heard at ignition switch ON?	Go to Step 5.	Go to Step 2.
2	Fuse check: Is fuse 8 in good condition?	Go to Step 3.	Check for short in circuits connected to this fuse.
3	Main Relay check: 1) Turn OFF ignition switch and remove main relay. 2) Check for proper connection to main relay at terminal E07-2 and E07-4. 3) If OK, check main relay for resistance and operation referring to "Main Relay Inspection" in section 6E2. Is check result satisfactory?	Go to Step 4.	Replace main relay.
4	ECM (PCM) Power Circuit check: 1) Turn OFF ignition switch, disconnect connectors from ECM (PCM) and install main relay. 2) Check for proper connection to ECM (PCM) at terminals C51-2-3, 20, 21 and E61-8. 3) If OK, then measure voltage between terminal C51-2-3 and ground, E61-8 and ground with ignition switch ON. Is each voltage 10 – 14 V?	Go to Step 5.	"B/W", "BI" or "B/R" circuit open.
5	ECM Power Circuit check: 1) Using service wire, ground terminal E61-8 and measure voltage between terminal C51-2-20 and ground at ignition switch ON. Is it 10 – 14 V?	Check ground circuits "B/G" and "B/BI" for open. If OK, then substitute a known-good ECM (PCM) and recheck.	Go to Step 6.
6	Is operating sound of main relay heard in Step 1?	Go to Step 7.	"B/R" or "BI" wire open.
7	Main Relay check: 1) Check main relay according to procedure in Step 3. Is main relay in good condition?	"B/R" or "BI" wire open.	Replace main relay.

# DTC P0100 MASS AIR FLOW SENSOR CIRCUIT MALFUNCTION (DTC No.33, 34)

## WIRING DIAGRAM

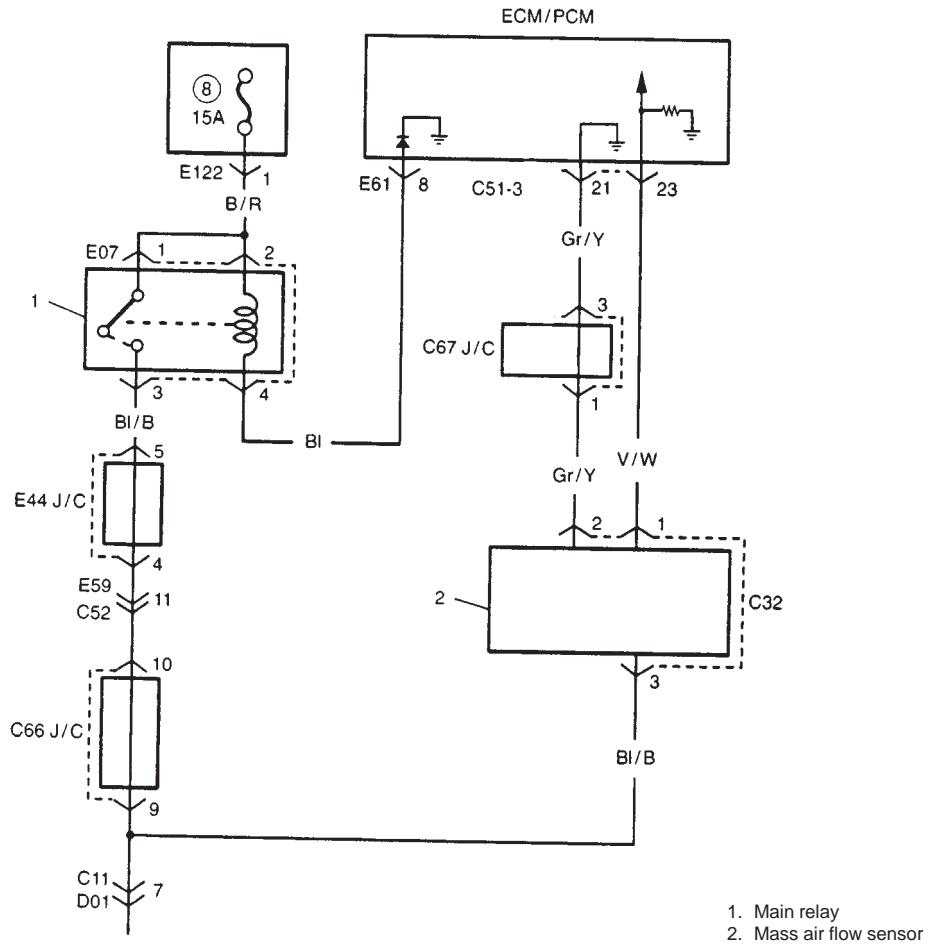

TERMINAL ARRANGEMENT OF ECM (PCM) COUPLER (VIEWED FROM HARNESS SIDE)

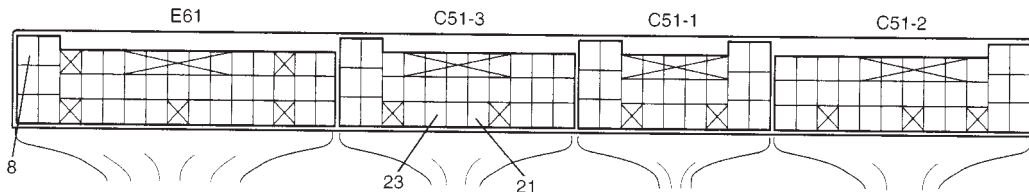

## DTC DETECTING CONDITION AND TROUBLE AREA

DTC DETECTING CONDITION	TROUBLE AREA
<ul style="list-style-type: none"> <li>● Engine running and more than 5.0 V MAF sensor output voltage continues for 1 sec.</li> <li>● Engine running and less than 0.3 V MAF sensor output voltage continues for 1 sec.</li> </ul>	Air intake system MAF sensor circuit MAF sensor MAP sensor ECM (PCM)

**DTC CONFIRMATION PROCEDURE****NOTE:**

Check to make sure that following conditions are satisfied when using this DTC CONFIRMATION PROCEDURE.

**WARNING:**

- When performing a road test, select a place where there is no traffic or possibility of a traffic accident and very careful during to avoid occurrence of an accident.
- Road test, should be carried out with 2 person, a driver and tester, on a level road.

- Intake air temperature: between  $-14^{\circ}\text{C}$  and  $70^{\circ}\text{C}$  ( $6.8^{\circ}\text{F}$  and  $158^{\circ}\text{F}$ )
- Atmospheric pressure: higher than 560 mmHg (Altitude: lower than 2790 m (9150 ft))

- (1) With ignition switch OFF, connect scan tool.
- (2) Turn ON ignition switch and clear DTC by using scan tool if any.
- (3) Start engine and run it for 10 sec.
- (4) Check DTC by using scan tool.

**DTC TROUBLESHOOTING**

STEP	ACTION	YES	NO
1	Was "ENGINE DIAG. FLOW TABLE" performed?	Go to Step 2.	Go to "ENGINE DIAG. FLOW TABLE".
2	MAF Sensor Power Supply Voltage check: (1) With ignition switch OFF, disconnect MAF sensor coupler (1). (2) With ignition switch ON, check voltage between C32-3 (2) and ground. Is voltage 10 – 14 V?	Go to Step 3.	Faulty "Bl/B" wire.
3	MAF Sensor Output Voltage check: (1) With ignition switch OFF, connect MAF sensor coupler. (2) Remove ECM (PCM) cover. (3) With ignition switch ON leaving engine OFF, check voltage between C51-3-23 and C51-3-21 terminal. Is voltage 0.5 – 1.0 V?	Poor C51-3-23 or/ and C51-3-21 terminal connection. If OK, substitute a known-good ECM (PCM) and recheck.	Faulty "V/W" wire and "Gr/Y" wire. Poor C32 coupler terminal connection. If wire and connection are OK, substitute a known-good MAF sensor and recheck.

Fig. for STEP 2

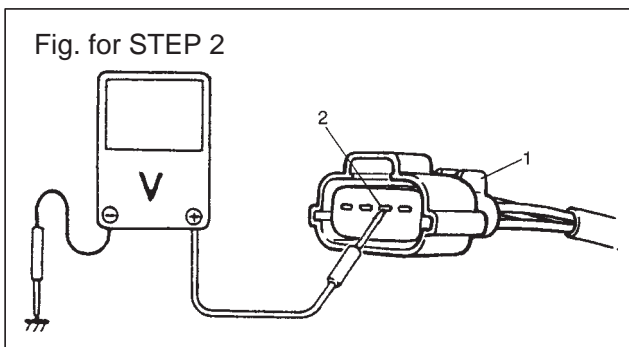

## DTC P0110 INTAKE AIR TEMP. CIRCUIT MALFUNCTION (DTC No.23, 25)

### WIRING DIAGRAM

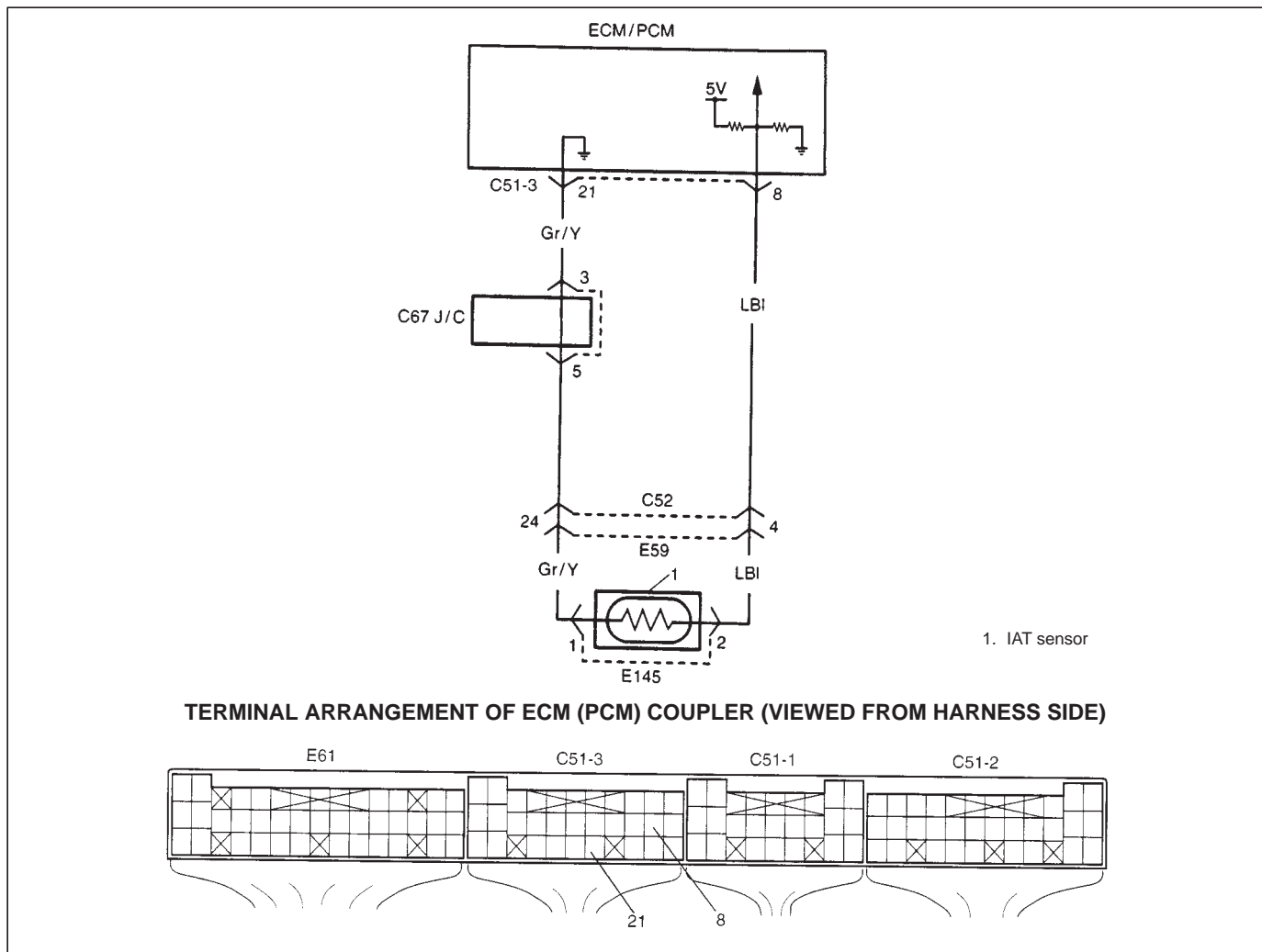

### DTC DETECTING CONDITION AND TROUBLE AREA

DTC DETECTING CONDITION	TROUBLE AREA
<ul style="list-style-type: none"> <li>• Less than 0.16 V IAT sensor output voltage continues for 5 sec.</li> <li>• More than 5.0 V IAT sensor output voltage continues for 5 sec.</li> </ul>	IAT sensor circuit IAT sensor ECM (PCM)

### DTC CONFIRMATION PROCEDURE

#### NOTE:

Check to make sure that following conditions are satisfied when using this DTC CONFIRMATION PROCEDURE.

#### WARNING:

- When performing a road test, select a place where there is no traffic or possibility of a traffic accident and very careful during to avoid occurrence of an accident.
- Road test, should be carried out with 2 person, a driver and tester, on a level road.

- Intake air temperature: between  $-14^{\circ}\text{C}$  and  $70^{\circ}\text{C}$  ( $68^{\circ}\text{F}$  and  $158^{\circ}\text{F}$ )
- Atmospheric pressure: higher than 560 mmHg (Altitude: lower than 2790 m (9150 ft))

- (1) With ignition switch OFF, connect scan tool.
- (2) Turn ON ignition switch, clear DTC if any.
- (3) Start engine and run it for 10 sec.
- (4) Check DTC by using scan tool.

## DTC TROUBLESHOOTING

STEP	ACTION	YES	NO
1	Was "ENGINE DIAG. FLOW TABLE" performed?	Go to Step 2.	Go to "ENGINE DIAG. FLOW TABLE".
2	Check IAT Sensor and Its Circuit. 1) Connect scan tool to DLC with ignition switch OFF. 2) Turn ignition switch ON. 3) Check intake air temp. displayed on scan tool. Is $-40^{\circ}\text{C}$ ( $-40^{\circ}\text{F}$ ) or $205^{\circ}\text{C}$ ( $401^{\circ}\text{F}$ ) indicated?	Go to Step 3.	Intermittent trouble. Check for intermittent referring to "Intermittent and Poor Connection" in Section 0A.
3	Check Wire Harness. 1) Disconnect IAT sensor connector (1) with ignition switch OFF. 2) Check for proper connection to IAT sensor at "LBI" and "Gr/Y" wire terminals. 3) If OK, then with ignition switch ON, is voltage applied to "LBI" wire terminal about 4.5 – 5.5 V?	Go to Step 5.	"LBI" wire open or shorted to power, or poor C51-3-8 connection. If wire and connection are OK, substitute a known-good ECM and recheck.
4	Does scan tool indicate $-40^{\circ}\text{C}$ ( $-40^{\circ}\text{F}$ ) at Step 2.	Go to Step 6.	Go to Step 5.
5	Check Wire Harness 1) Check intake air temp. displayed on scan tool with ignition switch ON. Is $-40^{\circ}\text{C}$ ( $-40^{\circ}\text{F}$ ) indicated?	Replace IAT sensor.	"LBI" wire shorted to ground. If wire is OK, substitute a known-good ECM and recheck.
6	Check Wire Harness. 1) Using service wire (2), connect IAT sensor connector terminals. 2) Check intake air temp. displayed on scan tool with ignition switch ON. Is $205^{\circ}\text{C}$ ( $401^{\circ}\text{F}$ ) indicated?	Replace IAT sensor.	"LBI" wire open or poor C51-3-21 connection. If wire and connection are OK, substitute a known-good ECM and recheck.

Fig. for STEP 3

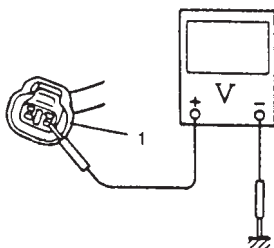
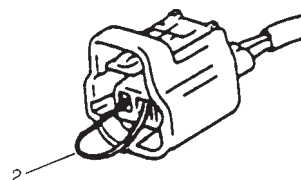
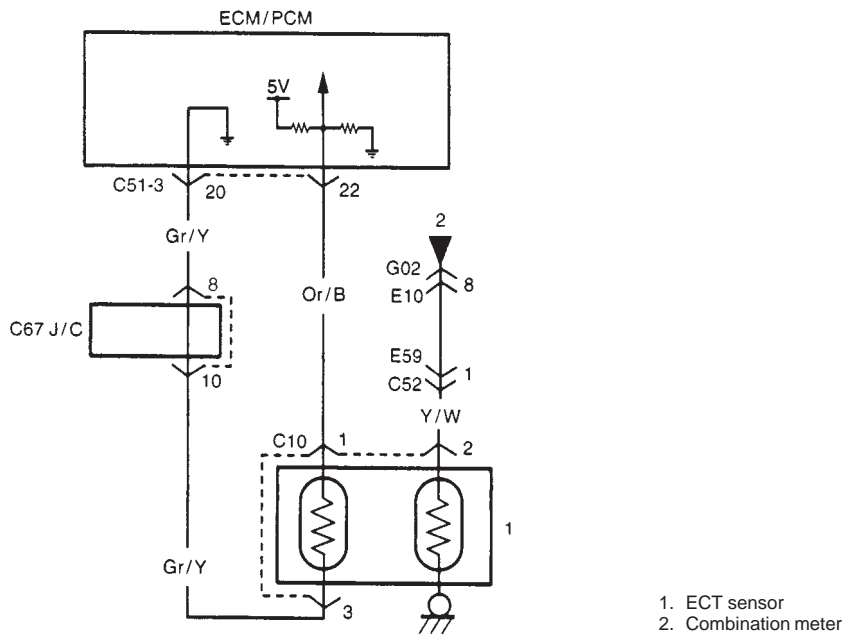

Fig. for STEP 6



## DTC P0115 ENGINE COOLANT TEMP. CIRCUIT MALFUNCTION (DTC No.14, 15)

### WIRING DIAGRAM



### TERMINAL ARRANGEMENT OF ECM (PCM) COUPLER (VIEWED FROM HARNESS SIDE)

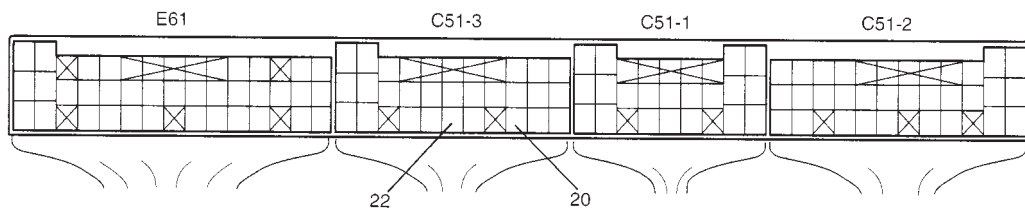

### DTC DETECTING CONDITION AND TROUBLE AREA

DTC DETECTING CONDITION	TROUBLE AREA
<ul style="list-style-type: none"> <li>ECT sensor signal terminal voltage is less than 0.16 V for 5 sec.</li> <li>ECT sensor signal terminal voltage is more than 5.0 V for 5 sec.</li> </ul>	ECT sensor ECT sensor circuit ECM (PCM)

### DTC CONFIRMATION PROCEDURE

#### NOTE:

Check to make sure that following conditions are satisfied when using this DTC CONFIRMATION PROCEDURE.

- Atmospheric pressure: higher than 560 mmHg (Altitude: lower than 2790 m (9150 ft))
- Intake air temperature: between  $-14^{\circ}\text{C}$  and  $70^{\circ}\text{C}$  ( $6.8^{\circ}\text{F}$  and  $158^{\circ}\text{F}$ )

- (1) With ignition switch OFF, connect scan tool.
- (2) Turn ON ignition switch, clear DTC if any.
- (3) Start engine and run it for 10 sec.
- (4) Check DTC by using scan tool.

### DTC TROUBLESHOOTING

STEP	ACTION	YES	NO
1	Was "ENGINE DIAG. FLOW TABLE" performed?	Go to Step 2.	Go to "ENGINE DIAG. FLOW TABLE".
2	Check ECT Sensor and Its Circuit. 1) Connect scan tool with ignition switch OFF. 2) Turn ignition switch ON. 3) Check engine coolant temp. displayed on scan tool. Is $-40^{\circ}\text{C}$ ( $-40^{\circ}\text{F}$ ) or $205^{\circ}\text{C}$ ( $401^{\circ}\text{F}$ ) indicated?	Go to Step 3.	Intermittent trouble. Check for intermittent referring to "Intermittent and Poor Connection" in Section 0 A.
3	Check Wire Harness. 1) Disconnect ECT sensor connector. 2) Check engine coolant temp. displayed on scan tool. Is $-40^{\circ}\text{C}$ ( $-40^{\circ}\text{F}$ ) indicated?	Replace ECT sensor.	"Or/B" wire shorted to ground. If wire is OK, substitute a known-good ECM and recheck.
4	Does scan tool indicate $-40^{\circ}\text{C}$ ( $-40^{\circ}\text{F}$ ) at Step 2.	Go to Step 6.	Go to Step 5.
5	Check Wire Harness. 1) Disconnect ECT sensor connector (1) with ignition switch OFF. 2) Check for proper connection to ECT sensor at "Gr/Y" and "Or/B" wire terminals. 3) If OK, then with ignition switch ON, is voltage applied to "Or/B" wire terminal about 4.5 – 5.5 V?	Go to Step 4.	"Or/B" wire open or shorted to power, or poor C51-3-22 connection. If wire and connection are OK, substitute a known-good ECM and recheck.
6	Check Wire Harness. 1) Using service wire (2), connect ECT sensor connector terminals. See Fig. 2. 2) Turn ignition switch ON and check engine coolant temp. displayed on scan tool. Is $205^{\circ}\text{C}$ ( $401^{\circ}\text{F}$ ) indicated?	Replace ECT sensor.	"Gr/Y" wire open or poor C51-3-20 connection. If wire and connection are OK, substitute a known-good ECM and recheck.

Fig. for STEP 5

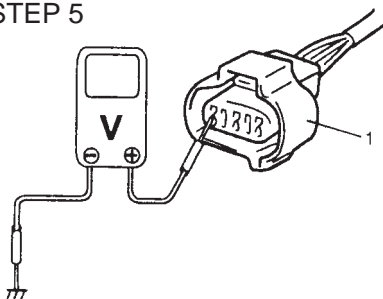
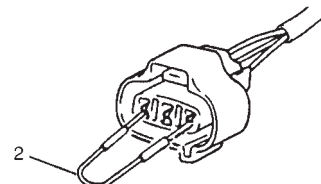
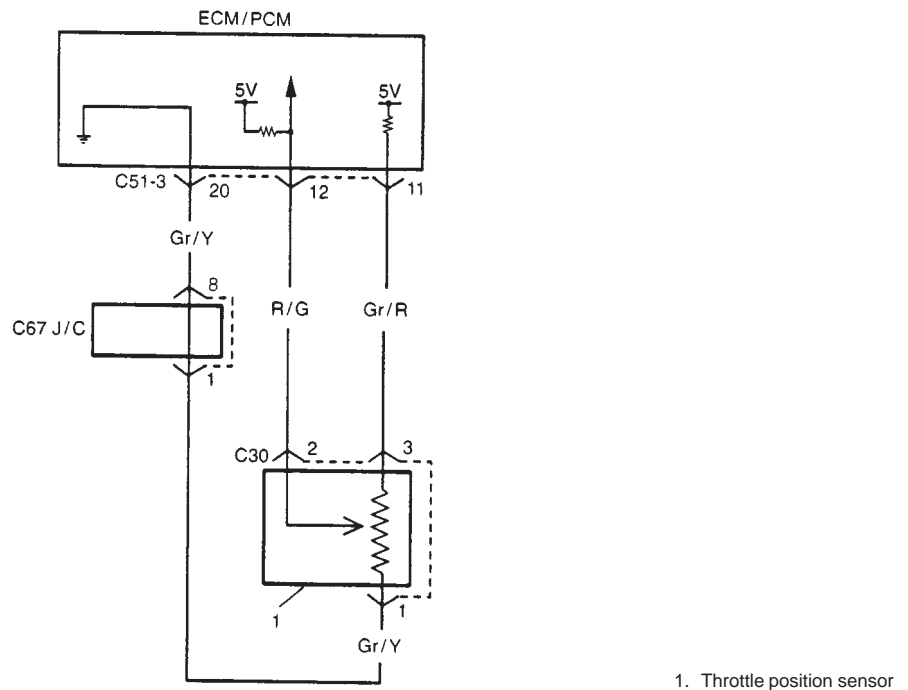

Fig. for STEP 6



## DTC P0120 THROTTLE POSITION CIRCUIT MALFUNCTION (DTC No.21, 22)

### WIRING DIAGRAM



#### TERMINAL ARRANGEMENT OF ECM (PCM) COUPLER (VIEWED FROM HARNESS SIDE)

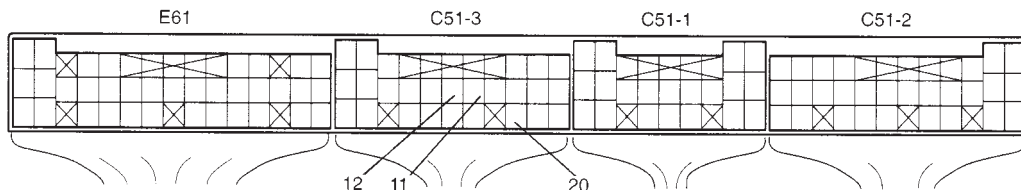

### DTC DETECTING CONDITION AND TROUBLE AREA

DTC DETECTING CONDITION	TROUBLE AREA
TP sensor signal terminal voltage continues less than 0.1 V for 1 sec. TP sensor signal terminal voltage continues more than 4.8 V for 1 sec.	TP sensor TP sensor circuit ECM (PCM)

### DTC CONFIRMATION PROCEDURE

#### NOTE:

Check to make sure that following conditions are satisfied when using this DTC CONFIRMATION PROCEDURE.

- Intake air temperature: between  $-14^{\circ}\text{C}$  and  $70^{\circ}\text{C}$  ( $6.8^{\circ}\text{F}$  and  $158^{\circ}\text{F}$ )
- Atmospheric pressure: higher than 560 mmHg (Altitude: lower than 2790 m (9150 ft))

- (1) With ignition switch OFF, connect scan tool.
- (2) Turn ON ignition switch and clear DTC by using scan tool if any.
- (3) Start engine and run it for 10 sec.
- (4) Check DTC by using scan tool.

## DTC TROUBLESHOOTING

STEP	ACTION	YES	NO
1	Was "ENGINE DIAG. FLOW TABLE" performed?	Go to Step 2.	Go to "ENGINE DIAG. FLOW TABLE".
2	TP Sensor Reference Voltage check: (1) Wit ignition switch OFF, disconnect C30-3 coupler. (2) Check voltage between C30-3 and ground. Is voltage 4.5 – 5.5 V?	Go to Step 3.	"Gr/R" wire open or shorted to ground circuit or power circuit or poor C51-3-11 connection. "Gr/Y" wire open or poor C51-3-20 connection. If OK, substitute a known-good ECM (PCM) and recheck.
3	TP Sensor check: 1) Check TP sensor referring to "ENGINE AND EMISSION CONTROL" section. Is check result as specified?	"R/G" wire open/shorted to ground circuit or power circuit or poor C51-3-12 connection. If OK, substitute a known-good ECM (PCM) and recheck.	

Fig. for STEP 2

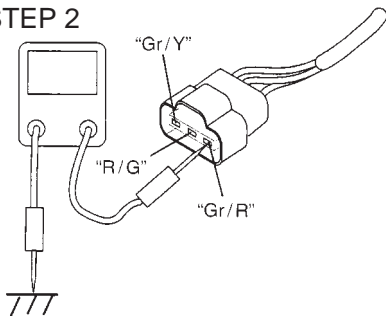

**DTC P0121 THROTTLE POSITION CIRCUIT PERFORMANCE PROBLEM****WIRING DIAGRAM**

Refer to DTC P0120 (DTC No.21, 22).

**DTC DETECTING CONDITION AND TROUBLE AREA**

DTC DETECTING CONDITION	TROUBLE AREA
Throttle opening is detected as small (rationality-low) while engine is running under high road and high speed conditions or as large (rationality-high) while engine is running under low load and low speed conditions.	Air intake system TP sensor TP sensor circuit ECM (PCM)

**DTC CONFIRMATION PROCEDURE****WARNING:**

- When performing a road test, select a place where there is no traffic or possibility of a traffic accident and very careful during to avoid occurrence of an accident.
- Road test, should be carried out with 2 person, a driver and tester, on a level road.

**NOTE:**

Check to make sure that following conditions are satisfied when using this DTC CONFIRMATION PROCEDURE.

- Intake air temperature: between  $-14^{\circ}\text{C}$  and  $70^{\circ}\text{C}$  ( $6.8^{\circ}\text{F}$  and  $158^{\circ}\text{F}$ )
- Atmospheric pressure: higher than 560 mmHg (Altitude: lower than 2790 m (9150 ft))

- (1) With ignition switch OFF, connect scan tool.
- (2) Turn ON ignition switch and clear DTC by using scan tool if any.
- (3) Start engine and warm up to normal operating temperature.
- (4) Increase vehicle till engine speed is reached 3300 – 3700 r/min. for 10 sec.
- (5) Stop vehicle and run engine at idle speed for 10 sec.
- (6) Check DTC and pending DTC by using scan tool.

## DTC TROUBLESHOOTING

STEP	ACTION	YES	NO
1	Was "ENGINE DIAG. FLOW TABLE" performed?	Go to Step 2.	Go to "ENGINE DIAG. FLOW TABLE".
2	TP Sensor Signal check: (1) Remove ECM (PCM) cover. (2) Start engine and warm up for normal operating temperature then stop engine. (3) With ignition switch ON leaving engine stop, check voltage between C51-3-12 and C51-3-20. Fully close: 0.35 – 0.65 V Fully open: 3.5 – 4.5 V Is check result as specified?	Go to Step 3.	Go to Step 4.
3	Air Intake System inspection: (1) Check air intake system for clog and air inhabit. Is air intake system in good condition?	Substitute a known-good ECM (PCM) and recheck.	Repair or replace.
4	TP Sensor Performance check: (1) Check TP sensor referring to "ENGINE AND EMISSION CONTROL" section. Is check result as specified?	Go to Step 5.	Faulty TP sensor.
5	TP Sensor Reference Voltage check: (1) With ignition switch OFF, disconnect TP sensor coupler (C30). (2) With ignition switch ON, check voltage between C30-3 and ground. Is the voltage 4.5 – 5.5 V?	Go to Step 6.	Faulty "Gr/R" wire. If OK, substitute a known-good ECM (PCM) and recheck.
6	TP Sensor Ground Circuit check: (1) Check continuity between C30-1 and ground. Is continuity in good condition?	Go to Step 7.	Faulty "Gr/Y" wire. If OK, substitute a known-good ECM (PCM) and recheck.
7	TP Sensor Installation check: (1) Check TP sensor installation referring to "ENGINE AND EMISSION CONTROL" section. Is TP sensor installation as specified?	Substitute a known-good ECM (PCM) and recheck.	Adjust TP sensor referring to "ENGINE AND EMISSION CONTROL" section and recheck.

Fig. for STEP 5

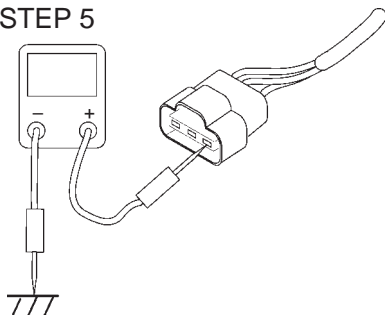

## DTC P0130 HO2S (BANK-1 SENSOR-1) CIRCUIT MALFUNCTION WIRING DIAGRAM

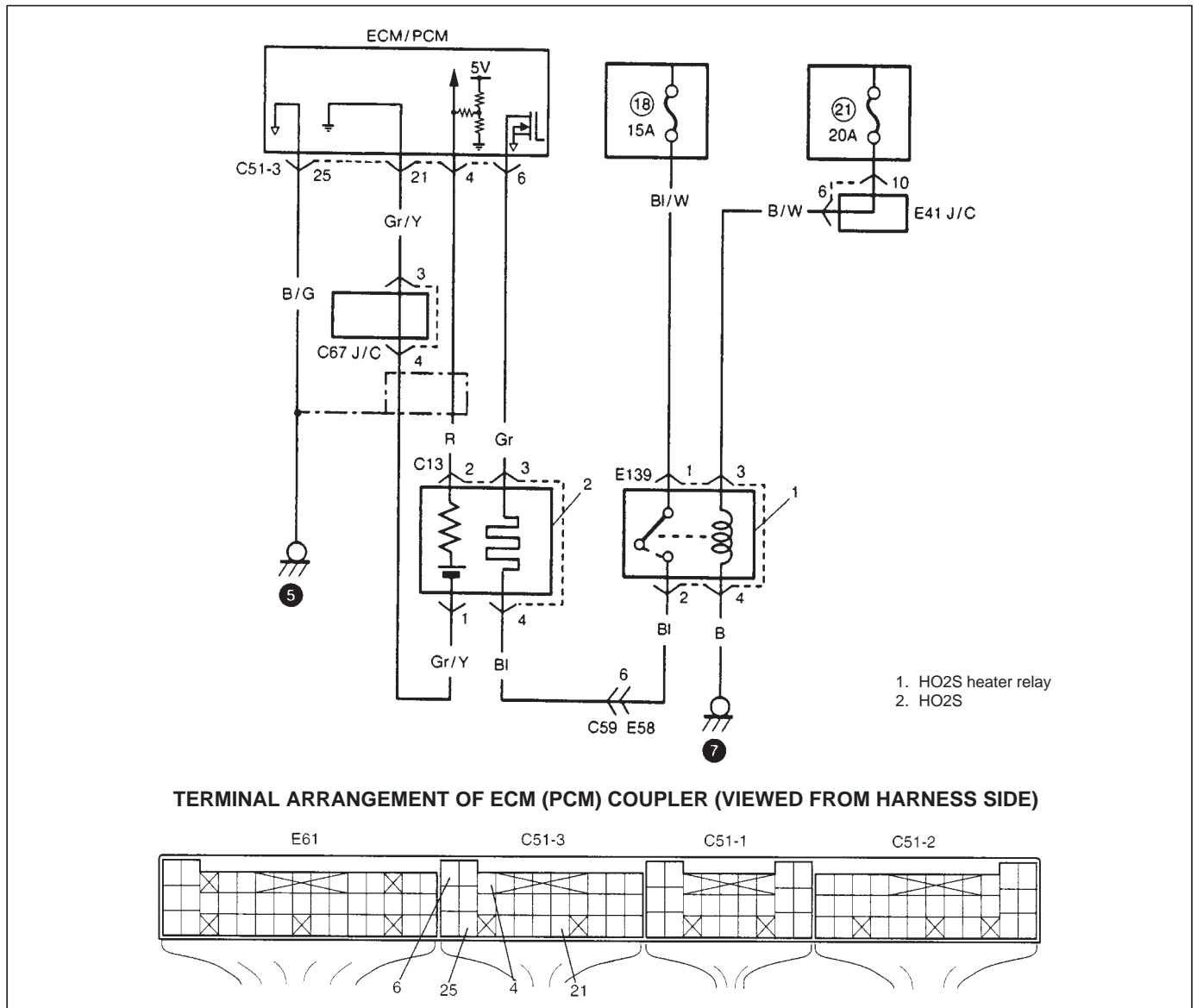

### DTC DETECTING CONDITION AND TROUBLE AREA

DTC DETECTING CONDITION	TROUBLE AREA
<ul style="list-style-type: none"> <li>• Minimum HO2S voltage is 0.4 V or higher.</li> <li>• Maximum HO2S voltage is higher than 1.2 V or less than 0.6 V.</li> </ul>	HO2S HO2S circuit Fuel injector Fuel pressure control system ECM (PCM)

### DTC CONFIRMATION PROCEDURE

**WARNING:**

- When performing a road test, select a place where there is no traffic or possibility of a traffic accident and very careful during to avoid occurrence of an accident.
- Road test, should be carried out with 2 person, a driver and tester, on a level road.

**NOTE:**

Check to make sure that following conditions are satisfied when using this DTC CONFIRMATION PROCEDURE.

- Intake air temperature: between  $-14^{\circ}\text{C}$  and  $70^{\circ}\text{C}$  ( $6.8^{\circ}\text{F}$  and  $158^{\circ}\text{F}$ )
- Atmospheric pressure: higher than 560 mmHg (Altitude: lower than 2790 m (9150 ft))
- Following DTC is not detected: P0135

- (1) With ignition switch OFF, connect scan tool.
- (2) Turn ON ignition switch and clear DTC by using scan tool if any.
- (3) Start engine and warm up to normal operating temperature.
- (4) Increase vehicle speed till engine speed is reached 2000 – 3000 r/min.
- (5) Keep above vehicle speed for 1 min. (Throttle valve operating is kept constant in this step.)
- (6) Stop vehicle and check DTC and pending DTC by using scan tool.

**DTC TROUBLESHOOTING**

STEP	ACTION	YES	NO
1	Was "ENGINE DIAG. FLOW TABLE" performed?	Go to Step 2.	Go to "ENGINE DIAG. FLOW TABLE".
2	HO2S Voltage check: (1) With ignition switch OFF, install scan tool. (2) Operate engine for 60 sec or more with following condition. Engine coolant temp. $> 70^{\circ}\text{C}$ Engine speed $> 2000$ r/min. (3) While repeating racing engine, check "O2S B1 S1" (HO2S voltage) displayed on scan tool. Is less than 0.4 V voltage displayed?	Intermittent trouble. If OK, substitute a known-good ECM (PCM) and recheck.	Go to Step 3.
3	HO2S Voltage check: (1) Remove ECM (PCM) cover. (2) Start engine and check voltage between C51-3-4 and C51-3-21 while repeating racing engine. Is the voltage while fuel is cut less than 0.1 V?	Substitute a known-good ECM (PCM) and recheck.	Go to Step 4.
4	HO2S Wire Harness check: (1) Check "R" and "Gr/Y" wire. Are they in good condition?	Go to Step 5.	Repair or replace.
5	Fuel Injector Circuit check: (1) Check fuel injector circuit referring to "TABLE B-2" in this section. Is it in good condition?	Go to Step 6.	Repair or replace.
6	Fuel Injector inspection: (1) Inspect fuel injectors (No.1, 3, 5) referring to "ENGINE AND EMISSION CONTROL" section. Are they in good condition?	Go to Step 7.	Faulty fuel injector(s).
7	Fuel Pressure inspection: (1) Check fuel pressure referring to following "TABLE B-3" in this section. Is fuel pressure within specification?	Replace HO2S and recheck. If DTC P0131 detected, substitute a known-good ECM (PCM) and recheck.	Repair or replace.

**DTC P0133 HO2S (BANK-1 SENSOR-1) CIRCUIT SLOW RESPONSE****WIRING DIAGRAM**

Refer to DTC P0130.

**DTC DETECTING CONDITION AND TROUBLE AREA**

DTC DETECTING CONDITION	TROUBLE AREA
Hi/Low switch cycle average of HO2S voltage is longer than 5 sec.	HO2S HO2S circuit ECM (PCM)

**DTC CONFIRMATION PROCEDURE****WARNING:**

- When performing a road test, select a place where there is no traffic or possibility of a traffic accident and very careful during to avoid occurrence of an accident.
- Road test, should be carried out with 2 person, a driver and tester, on a level road.

**NOTE:**

Check to make sure that following conditions are satisfied when using this DTC CONFIRMATION PROCEDURE.

- Intake air temperature: between  $-14^{\circ}\text{C}$  and  $70^{\circ}\text{C}$  ( $6.8^{\circ}\text{F}$  and  $158^{\circ}\text{F}$ )
- Atmospheric pressure: higher than 560 mmHg (Altitude: lower than 2790 m (9150 ft))
- Following DTC is not detected: P0135

- (1) With ignition switch OFF, connect scan tool.
- (2) Turn ON ignition switch and clear DTC by using scan tool if any.
- (3) Start engine and warm up to normal operating temperature.
- (4) Increase vehicle speed to 80 – 100 km/h (50 – 60 mph). (engine speed; 2500 – 3000 r/min.)
- (5) Keep above vehicle speed for 1 min. (Throttle valve operating is kept constant in this step.)
- (6) Stop vehicle and check DTC and pending DTC by using scan tool.

**DTC TROUBLESHOOTING**

STEP	ACTION	YES	NO
1	Was "ENGINE DIAG. FLOW TABLE" performed?	Go to Step 2.	Go to "ENGINE DIAG. FLOW TABLE".
2	Wire Harness check: (1) Check "R" and "Gr/Y" wire. Are they in good condition?	Go to Step 3.	Repair or replace.
3	(1) Replace HO2S (B-1 S-1) and recheck. Is DTC P0133 detected?	Substitute a known-good ECM (PCM) and recheck.	Faulty HO2S (B-1 S-1).

## DTC P0134 HO2S (BANK-1 SENSOR-1) NO ACTIVITY DETECTED (DTC No.13)

### WIRING DIAGRAM

Refer to DTC P0130.

### DTC DETECTING CONDITION AND TROUBLE AREA

DTC DETECTING CONDITION	TROUBLE AREA
HO2S voltage is lower than 0.5 V.	HO2S HO2S circuit Fuel injector Fuel pressure control system ECM (PCM)

### DTC CONFIRMATION PROCEDURE

#### WARNING:

- When performing a road test, select a place where there is no traffic or possibility of a traffic accident and very careful during to avoid occurrence of an accident.
- Road test, should be carried out with 2 person, a driver and tester, on a level road.

#### NOTE:

Check to make sure that following conditions are satisfied when using this DTC CONFIRMATION PROCEDURE.

- Intake air temperature: between  $-14^{\circ}\text{C}$  and  $70^{\circ}\text{C}$  ( $6.8^{\circ}\text{F}$  and  $158^{\circ}$ )
- Atmospheric pressure: higher than 560 mmHg (Altitude: lower than 2790 m (9150 ft))
- Following DTCs are not detected: P0100, P0115 and P0135

- (1) With ignition switch OFF, connect scan tool.
- (2) Turn ON ignition switch and clear DTC by using scan tool if any.
- (3) Start engine and warm up to normal operating temperature (Run engine for 2 min. or more).
- (4) Increase vehicle speed to 65 – 80 km/h (40 – 50 mph).
- (5) Keep above vehicle speed for 2 min. (Throttle valve operating is kept constant in this step.)
- (6) Stop vehicle and check DTC and pending DTC by using scan tool.

### DTC TROUBLE SHOOTING

STEP	ACTION	YES	NO
1	Was "ENGINE DIAG. FLOW TABLE" performed?	Go to Step 2.	Go to "ENGINE DIAG. FLOW TABLE".
2	HO2S Voltage check: (1) With ignition switch OFF, install scan tool. (2) Operate engine for 60 sec. or more with following condition. Engine coolant temp. $> 70^{\circ}\text{C}$ Engine speed $> 2000$ r/min. (3) With above condition, check "O2S B1 S1" (HO2S voltage) displayed on scan tool. Does above voltage deflect over and under 0.5 V?	Intermittent trouble. If OK, substitute a known-good ECM (PCM) and recheck.	Go to Step 3.

STEP	ACTION	YES	NO
3	HO2S Voltage check: (1) Remove ECM (PCM) cover. (2) Start engine and check voltage between C51-3-4 and C51-3-21 while repeating racing engine. Does the voltage indicate 0.5 V or more even at once?	Poor C51-3-4 and/or C51-3-21 terminal connection. If OK, substitute a known-good ECM (PCM) and recheck.	Go to Step 4.
4	Wire Harness check: (1) Check "R" and "Gr/Y" wire. Are they in good condition?	Go to Step 5.	Repair or replace.
5	Fuel Injector Circuit check: (1) Check fuel injector circuit referring to "TABLE B-2" in this section. Is it in good condition?	Go to Step 6.	Repair or replace.
6	Fuel Injector inspection: (1) Inspect fuel injectors (No.1, 3, 5) referring to "ENGINE AND EMISSION CONTROL" section. Are they in good condition?	Go to Step 7.	Faulty fuel injector(s).
7	Fuel Pressure inspection: (1) Check fuel pressure referring to following "TABLE B-3" in this section. Is fuel pressure within specification?	Replace HO2S and recheck. If DTC P0134 (DTC No.13) detected, substitute a known-good ECM (PCM) and recheck.	Repair or replace.

**DTC P0135 HO2S (BANK-1 SENSOR-1) HEATER CIRCUIT MALFUNCTION****WIRING DIAGRAM**

Refer to DTC P0130.

**DTC DETECTING CONDITION AND TROUBLE AREA**

DTC DETECTING CONDITION	TROUBLE AREA
Current of HO2S heater is higher than specified value or lower than specified value.	HO2S HO2S circuit ECM (PCM)

**DTC CONFIRMATION PROCEDURE****WARNING:**

- When performing a road test, select a place where there is no traffic or possibility of a traffic accident and very careful during to avoid occurrence of an accident.
- Road test, should be carried out with 2 person, a driver and tester, on a level road.

**NOTE:**

Check to make sure that following conditions are satisfied when using this DTC CONFIRMATION PROCEDURE.

- Intake air temperature: between  $-14^{\circ}\text{C}$  and  $70^{\circ}\text{C}$  ( $6.8^{\circ}\text{F}$  and  $158^{\circ}\text{F}$ )
  - Atmospheric pressure: higher than 560 mmHg (Altitude: lower than 2790 m (9150 ft))
- (1) With ignition switch OFF, connect scan tool.
  - (2) Turn ON ignition switch and clear DTC by using scan tool if any.
  - (3) Start engine and warm up to normal operating temperature.
  - (4) Increase vehicle speed to 56 km/h (35 mph) or more.
  - (5) Keep above vehicle speed for 5 min. (Throttle valve operating is kept constant in this step.)
  - (6) Stop vehicle and run engine at idle speed for 1 min.
  - (7) Check DTC and pending DTC by using scan tool.

**DTC TROUBLESHOOTING**

STEP	ACTION	YES	NO
1	Was "ENGINE DIAG. FLOW TABLE" performed?	Go to Step 2.	Go to "ENGINE DIAG. FLOW TABLE".
2	HO2S Heater check: (1) With ignition switch OFF, disconnect HO2S heater relay. (2) Check resistance between C51-3-6 and E139-2. Is the resistance 3 – 3.6 $\Omega$ at 20°C?	Go to Step 3.	Faulty "Bl", "Gr" wire. Faulty HO2S.
3	HO2S Heater Power Supply check: (1) With ignition switch ON leaving engine OFF, check voltage between E139-3 and ground, E139-1 and ground. Is each voltage 10 – 14 V?	Go to Step 4.	18 and/or 21 fuse blown. If OK, faulty "B/W" wire or "Bl/W" wire.
4	HO2S Heater Control Circuit check: (1) With ignition switch OFF, install HO2S heater relay. (2) With ignition switch ON leaving engine OFF, check voltage between C51-3-6 and ground. Is the voltage 10 – 14 V?	Substitute a known-good ECM (PCM) and recheck.	Faulty HO2S heater relay or "Gr" wire shorted to ground circuit. If OK, substitute a known-good ECM (PCM) and recheck.

Fig. for STEP 2, 3

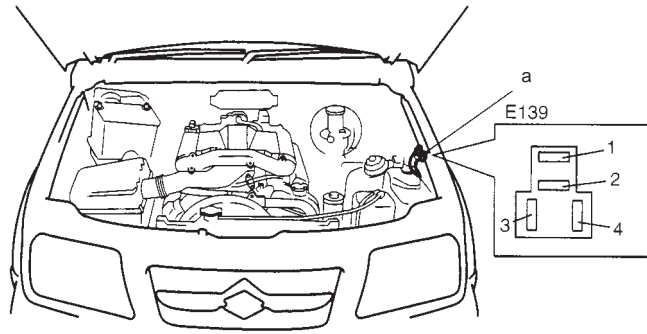

a. HO2S heater relay

## DTC P0136 HO2S (BANK-1 SENSOR-2) CIRCUIT MALFUNCTION WIRING DIAGRAM

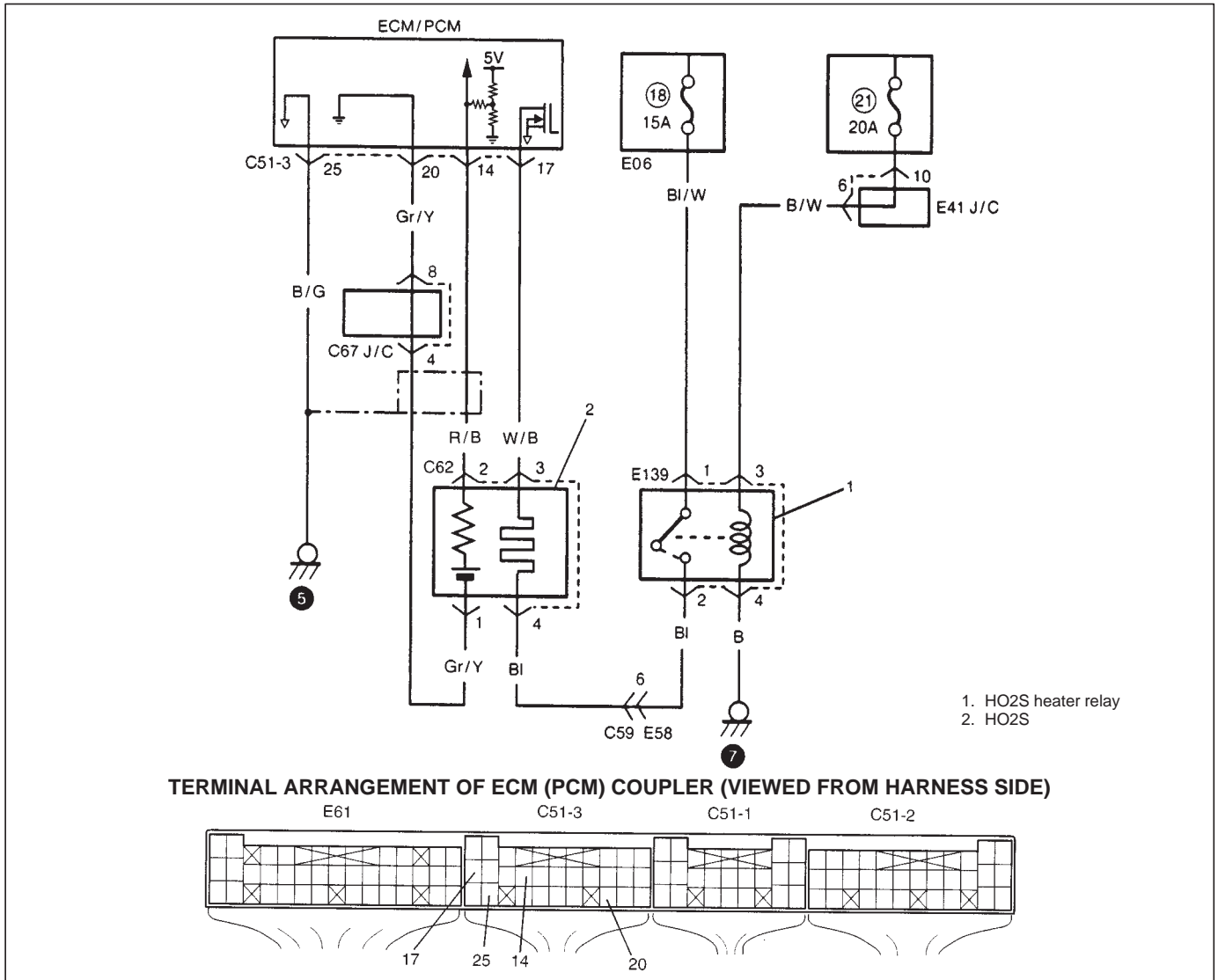

### DTC DETECTING CONDITION AND TROUBLE AREA

DTC DETECTION CONDITION	TROUBLE AREA
Maximum HO2S voltage is higher than 2.0 V for 20 sec. Maximum HO2S voltage is less than 0.35 V for 8 min. Maximum HO2S voltage is higher than 2.5 V for 4 sec. while fuel is cut.	HO2S HO2S circuit Fuel injector Fuel pressure control system ECM (PCM)

### DTC CONFIRMATION PROCEDURE

#### NOTE:

Check to make sure that following conditions are satisfied when using this DTC CONFIRMATION PROCEDURE.

#### WARNING:

- When performing a road test, select a place where there is no traffic or possibility of a traffic accident and very careful during to avoid occurrence of an accident.
- Road test, should be carried out with 2 person, a driver and tester, on a level road.

- Intake air temperature: between  $-14^{\circ}\text{C}$  and  $70^{\circ}\text{C}$  ( $6.8^{\circ}\text{F}$  and  $158^{\circ}\text{F}$ )
- Atmospheric pressure: higher than 560 mmHg (Altitude: lower than 2790 m (9150 ft))
- Following DTCs are not detected: P0110 (No.23, 25), P0335, P0460, P1450 and P1451

- (1) With ignition switch OFF, connect scan tool.
- (2) Turn ON ignition switch and clear DTC by using scan tool if any.
- (3) Start engine and warm up to normal operating temperature.
- (4) Increase vehicle speed to 56 km/h (35 mph) or more.
- (5) Keep above vehicle speed for 5 min. (Throttle valve operating is kept constant in this step.)
- (6) Increase vehicle speed to 80 – 100 km/h (50 – 60 mph). (engine speed; 2500 – 3000 r/min.)
- (7) Keep above vehicle speed for 1 min. (Throttle valve operating is kept constant in this step.)
- (8) Release accelerator pedal and with engine brake applied, keep vehicle coasting and then stop vehicle.
- (9) Check DTC and pending DTC by using scan tool.

## DTC TROUBLESHOOTING

STEP	ACTION	YES	NO
1	Was "ENGINE DIAG. FLOW TABLE" performed?	Go to Step 2.	Go to "ENGINE DIAG. FLOW TABLE".
2	HO2S Voltage check: (1) With ignition switch OFF, install scan tool. (2) Start engine and check "O2S B1 S2" (HO2S voltage) displayed on scan tool while repeating racing engine. Does the voltage deflect between 0 – 0.25 V and 0.35 – 2.0 V?	Intermittent trouble. If OK, substitute a known-good ECM (PCM) and recheck.	Go to Step 3.
3	Wire Harness check: (1) Check "R/B" and "Gr/Y" wire. Are they in good condition?	Go to Step 4.	Repair or replace.
4	Fuel Injector Circuit check: (1) Check fuel injector circuit referring to "TABLE B-2" in this section. Is it in good condition?	Go to Step 5.	Repair or replace.
5	Fuel Injection inspection: (1) Inspect fuel injectors (No.1, 3, 5) referring to "ENGINE AND EMISSION CONTROL" section. Are they in good condition?	Go to Step 6.	Faulty fuel injector(s).
6	Fuel Pressure inspection: (1) Check fuel pressure referring to following "TABLE B-3" in this section. Is fuel pressure within specification?	Replace HO2S and recheck. If DTC P0136 detected, substitute a known-good ECM (PCM) and recheck.	Repair or replace.

**DTC P0141 HO2S (BANK-1 SENSOR-2) HEATER CIRCUIT MALFUNCTION****WIRING DIAGRAM**

Refer to DTC P0136.

**DTC DETECTING CONDITION AND TROUBLE AREA**

DTC DETECTING CONDITION	TROUBLE AREA
Current of HO2S heater is higher than specified value or lower than specified value.	HO2S HO2S circuit ECM (PCM)

**DTC CONFIRMATION PROCEDURE****NOTE:**

Check to make sure that following conditions are satisfied when using this DTC CONFIRMATION PROCEDURE.

**WARNING:**

- When performing a road test, select a place where there is no traffic or possibility of a traffic accident and very careful during to avoid occurrence of an accident.
- Road test, should be carried out with 2 person, a driver and tester, on a level road.

- Intake air temperature: between  $-14^{\circ}\text{C}$  and  $70^{\circ}\text{C}$  ( $6.8^{\circ}\text{F}$  and  $158^{\circ}\text{F}$ )
- Atmospheric pressure: higher than 560 mmHg (Altitude: lower than 2790 m (9150 ft))

- (1) With ignition switch OFF, connect scan tool.
- (2) Turn ON ignition switch and clear DTC by using scan tool if any.
- (3) Start engine and warm up to normal operating temperature.
- (4) Increase vehicle speed to 56 km/h (35 mph) or more.
- (5) Keep above vehicle speed for 5 min. (Throttle valve operating is kept constant in this step.)
- (6) Stop vehicle and run engine at idle speed for 1 min.
- (7) Check DTC and pending DTC by using scan tool.

**DTC TROUBLESHOOTING**

STEP	ACTION	YES	NO
1	Was "ENGINE DIAG. FLOW TABLE" performed?	Go to Step 2.	Go to "ENGINE DIAG. FLOW TABLE".
2	HO2S Heater check: (1) With ignition switch OFF, disconnect HO2S heater relay. (2) Check resistance between C51-3-17 and E139-2. Is the resistance 5 – 7 $\Omega$ at $20^{\circ}\text{C}$ ?	Go to Step 3.	Faulty "Bl", "W/B" wire. Faulty HO2S.
3	HO2S Heater Power Supply check: (1) With ignition switch ON leaving engine OFF, check voltage between E139-3 and ground, E139-1 and ground Is each voltage 10 – 14 V?	Go to Step 4.	Fuse 18 and/or 21 blown. If OK, faulty "B/W" wire or "Bl/W" wire.

STEP	ACTION	YES	NO
4	HO2S Heater Control Circuit check: (1) With ignition switch OFF, install HO2S heater relay. (2) With ignition switch ON leaving engine OFF, check voltage between C51-3-17 and ground. Is the voltage 10 – 14 V?	Substitute a known-good ECM (PCM) and recheck.	Faulty HO2S heater relay or "W/B" wire shorted to ground circuit. If OK, substitute a known-good ECM (PCM) and recheck.

Fig. for STEP 2, 3

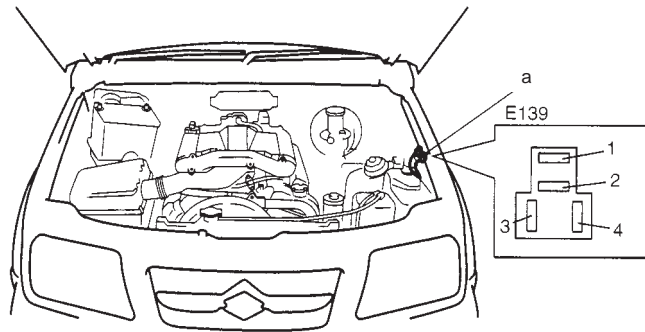

a. HO2S heater relay

## DTC P0150 HO2S (BANK-2 SENSOR-1) CIRCUIT MALFUNCTION WIRING DIAGRAM

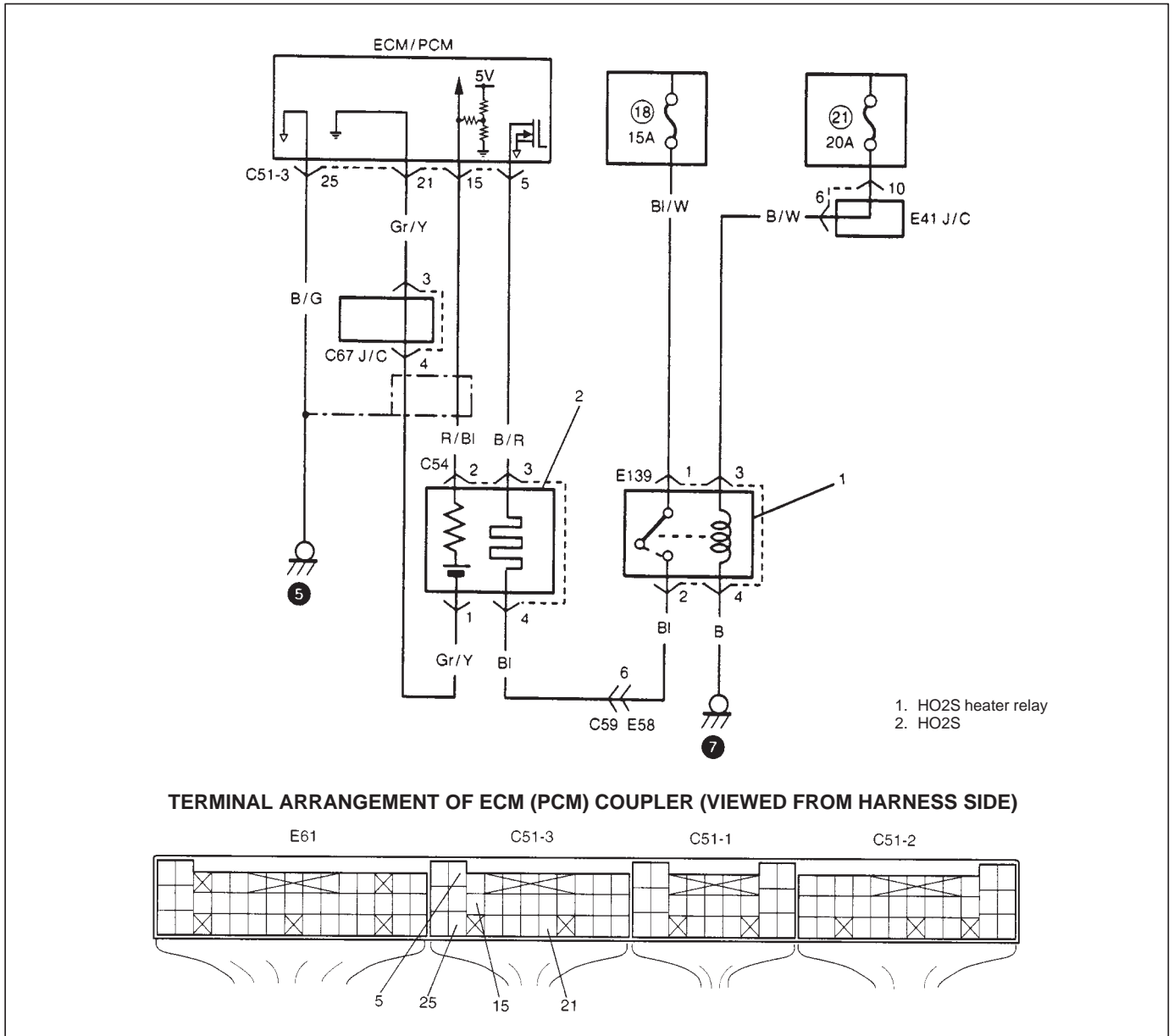

### DTC DETECTING CONDITION AND TROUBLE AREA

DTC DETECTING CONDITION	TROUBLE AREA
<ul style="list-style-type: none"> <li>Minimum HO2S voltage is 0.4 V or higher.</li> <li>Maximum HO2S voltage is higher than 1.2 V or less than 0.6 V.</li> </ul>	HO2S HO2S circuit Fuel injector Fuel pressure control system ECM (PCM)

### DTC CONFIRMATION PROCEDURE

#### NOTE:

Check to make sure that following conditions are satisfied when using this DTC CONFIRMATION PROCEDURE.

**WARNING:**

- When performing a road test, select a place where there is no traffic or possibility of a traffic accident and very careful during to avoid occurrence of an accident.
- Road test, should be carried out with 2 person, a driver and tester, on a level road.

- Intake air temperature: between  $-14^{\circ}\text{C}$  and  $70^{\circ}\text{C}$  ( $6.8^{\circ}\text{F}$  and  $158^{\circ}\text{F}$ )
- Atmospheric pressure: higher than 560 mmHg (Altitude: lower than 2790 m (9150 ft))
- Following DTC is not detected: P0135

- (1) With ignition switch OFF, connect scan tool.
- (2) Turn ON ignition switch and clear DTC by using scan tool if any.
- (3) Start engine and warm up to normal operating temperature.
- (4) Increase vehicle speed till engine speed is reached 2000 – 3000 r/min.
- (5) Keep above vehicle speed for 1 min. (Throttle valve operating is kept constant in this step.)
- (6) Stop vehicle and check DTC and pending DTC by using scan tool.

**DTC TROUBLESHOOTING**

STEP	ACTION	YES	NO
1	Was "ENGINE DIAG. FLOW TABLE" performed?	Go to Step 2.	Go to "ENGINE DIAG. FLOW TABLE".
2	HO2S Voltage check: (1) With ignition switch OFF, install scan tool. (2) Operate engine for 60 sec. or more with following condition. Engine coolant temp. $> 70^{\circ}\text{C}$ Engine speed $> 2000$ r/min. (3) While repeating racing engine, check "O2S B1 S1" (HO2S voltage) displayed on scan tool. Is less than 0.4 V voltage displayed?	Intermittent trouble. If OK, substitute a known-good ECM (PCM) and recheck.	Go to Step 3.
3	HO2S Voltage check: (1) Remove ECM (PCM) cover. (2) Start engine and check voltage between C51-3-15 and C51-3-21 while repeating racing engine. Is the voltage while fuel is cut less than 0.1 V?	Substitute a known-good ECM (PCM) and recheck.	Go to Step 4.
4	HO2S Wire Harness check: (1) Check "R/Bl" and "Gr/Y" wire. Are they in good condition?	Go to Step 5.	Repair or replace.
5	Fuel Injector Circuit check: (1) Check fuel injector circuit referring to "TABLE B-2" in this section. Is it in good condition?	Go to Step 6.	Repair or replace.
6	Fuel Injector inspection: (1) Inspect fuel injectors (No.2, 4, 6) referring to "ENGINE AND EMISSION CONTROL" section. Are they in good condition?	Go to Step 7.	Faulty fuel injector(s).
7	Fuel Pressure inspection: (1) Check fuel pressure referring to following "TABLE B-3" in this section. Is fuel pressure within specification?	Replace HO2S and recheck. If DTC P0151 detected, substitute a known good ECM (PCM) and recheck.	Repair or replace.

**DTC P0153 HO2S (BANK-2 SENSOR-1) CIRCUIT SLOW RESPONSE****WIRING DIAGRAM**

Refer to DTC P0150 (DTC No.26).

**DTC DETECTING CONDITION AND TROUBLE AREA**

DTC DETECTING CONDITION	TROUBLE AREA
Hi/Low switch cycle average of HO2S voltage is longer than 5 sec.	HO2S HO2S circuit ECM (PCM)

**DTC CONFIRMATION PROCEDURE****NOTE:**

Check to make sure that following conditions are satisfied when using this DTC CONFIRMATION PROCEDURE.

**WARNING:**

- When performing a road test, select a place where there is no traffic or possibility of a traffic accident and very careful during to avoid occurrence of an accident.
- Road test, should be carried out with 2 person, a driver and tester, on a level road.

- Intake air temperature: between  $-14^{\circ}\text{C}$  and  $70^{\circ}\text{C}$  ( $6.8^{\circ}\text{F}$  and  $158^{\circ}\text{F}$ )
- Atmospheric pressure: higher than 560 mmHg (Altitude: lower than 2790 m (9150 ft))
- Following DTC is not detected: P0135

- (1) With ignition switch OFF, connect scan tool.
- (2) Turn ON ignition switch and clear DTC by using scan tool if any.
- (3) Start engine and warm up to normal operating temperature.
- (4) Increase vehicle speed to 80 – 100 km/h (50 – 60 mph). (engine speed; 2500 – 3000 r/min.)
- (5) Keep above vehicle speed for 1 min. (Throttle valve operating is kept constant in this step.)
- (6) Stop vehicle and check DTC and pending DTC by using scan tool.

**DTC TROUBLESHOOTING**

STEP	ACTION	YES	NO
1	Was "ENGINE DIAG. FLOW TABLE" performed?	Go to Step 2.	Go to "ENGINE DIAG. FLOW TABLE".
2	Wire Harness check: (1) Check "R/Bl" and "Gr/Y" wire. Are they in good condition?	Go to Step 3.	Repair or replace.
3	(1) Replace HO2S (B-2 S-1) and recheck. Is DTC P0153 detected?	Substitute a known-good ECM (PCM) and recheck.	Faulty HO2S (B-2 S-1).

## DTC P0154 HO2S (BANK-2 SENSOR-1) NO ACTIVITY DETECTED (DTC No.26)

### WIRING DIAGRAM

Refer to DTC P0150.

### DTC DETECTING CONDITION AND TROUBLE AREA

DTC DETECTING CONDITION	TROUBLE AREA
HO2S voltage is lower than 0.5 V.	HO2S HO2S circuit Fuel injector Fuel pressure control system ECM (PCM)

### DTC CONFIRMATION PROCEDURE

#### NOTE:

Check to make sure that following conditions are satisfied when using this DTC CONFIRMATION PROCEDURE.

#### WARNING:

- When performing a road test, select a place where there is no traffic or possibility of a traffic accident and very careful during to avoid occurrence of an accident.
- Road test, should be carried out with 2 person, a driver and tester, on a level road.

- Intake air temperature: between  $-14^{\circ}\text{C}$  and  $70^{\circ}\text{C}$  ( $6.8^{\circ}\text{F}$  and  $158^{\circ}\text{F}$ )
- Atmospheric pressure: higher than 560 mmHg (Altitude: lower than 2790 m (9150 ft))
- Following DTCs are not detected: P0100 (No.33, 34), P0115 (No.14, 15) and P0135

- (1) With ignition switch OFF, connect scan tool.
- (2) Turn ON ignition switch and clear DTC by using scan tool if any.
- (3) Start engine and warm up to normal operating temperature (Run engine for 2 min. or more).
- (4) Increase vehicle speed to 65 – 80 km/h (40 – 50 mph).
- (5) Keep above vehicle speed for 2 min. (Throttle valve operating is kept constant in this step.)
- (6) Stop vehicle and check DTC and pending DTC by using scan tool.

### DTC TROUBLESHOOTING

STEP	ACTION	YES	NO
1	Was "ENGINE DIAG. FLOW TABLE" performed?	Go to Step 2.	Go to "ENGINE DIAG. FLOW TABLE".
2	HO2S Voltage check: (1) With ignition switch OFF, install scan tool. (2) Operate engine for 60 sec. or more with following condition. Engine coolant temp. $> 70^{\circ}\text{C}$ Engine speed $> 2000$ r/min. (3) With above condition, check "O2S B2 S1" (HO2S voltage) displayed on scan tool. Does above voltage deflect over and under 0.5 V?	Intermittent trouble. If OK, substitute a known-good ECM (PCM) and recheck.	Go to Step 3.

STEP	ACTION	YES	NO
3	HO2S Voltage check: (1) Remove ECM (PCM) cover. (2) Start engine and check voltage between C51-3-15 and C51-3-21 while repeating racing engine. Does the voltage indicate 0.5 V or more even at once?	Poor C51-3-15 and/or C51-3-21 terminal connection. If OK, substitute a known-good ECM (PCM) and recheck.	Go to Step 4.
4	Wire Harness check: (1) Check "R/Bl" and "Gr/Y" wire. Are they in good condition?	Go to Step 5.	Repair or replace.
5	Fuel Injector Circuit check: (1) Check fuel injector circuit referring to "TABLE B-2" in this section. Is it in good condition?	Go to Step 6.	Repair or replace.
6	Fuel Injector inspection: (1) Inspect fuel injectors (No.2, 4, 6) referring to "ENGINE AND EMISSION CONTROL" section. Are they in good condition?	Go to Step 7.	Faulty fuel injector(s).
7	Fuel Pressure inspection: (1) Check fuel pressure referring to following "TABLE B-3" in this section. Is fuel pressure within specification?	Replace HO2S and recheck. If DTC P0154 (DTC No.26) detected, substitute a known-good ECM (PCM) and recheck.	Repair or replace.

**DTC P0155 HO2S (BANK-2 SENSOR-1) HEATER CIRCUIT MALFUNCTION****WIRING DIAGRAM**

Refer to DTC P0150.

**DTC DETECTING CONDITION AND TROUBLE AREA**

DTC DETECTING CONDITION	TROUBLE AREA
Current of HO2S heater is higher than specified value or lower than specified value.	HO2S HO2S circuit ECM (PCM)

**DTC CONFIRMATION PROCEDURE****NOTE:**

Check to make sure that following conditions are satisfied when using this DTC CONFIRMATION PROCEDURE.

**WARNING:**

- When performing a road test, select a place where there is no traffic or possibility of a traffic accident and very careful during to avoid occurrence of an accident.
- Road test, should be carried out with 2 person, a driver and tester, on a level road.

- Intake air temperature: between  $-14^{\circ}\text{C}$  and  $70^{\circ}\text{C}$  ( $6.8^{\circ}\text{F}$  and  $158^{\circ}\text{F}$ )
- Atmospheric pressure: higher than 560 mmHg (Altitude: lower than 2790 m (9150 ft))

- (1) With ignition switch OFF, connect scan tool.
- (2) Turn ON ignition switch and clear DTC by using scan tool if any.
- (3) Start engine and warm up to normal operating temperature.
- (4) Increase vehicle speed to 56 km/h (35 mph) or more.
- (5) Keep above vehicle speed for 5 min. (Throttle valve operating is kept constant in this step.)
- (6) Stop vehicle and run engine at idle speed for 1 min.
- (7) Check DTC and pending DTC by using scan tool.

**DTC TROUBLESHOOTING**

STEP	ACTION	YES	NO
1	Was "ENGINE DIAG. FLOW TABLE" performed?	GO to Step 2.	Go to "ENGINE DIAG. FLOW TABLE".
2	HO2S Heater check: (1) With ignition switch OFF, disconnect HO2S heater relay. (2) Check resistance between C51-3-5 and E139-2. Is the resistance 3 – 3.6 $\Omega$ at 20°C?	Go to Step 3.	Faulty "BI", "B/R" wire. Faulty HO2S.
3	HO2S Heater Power Supply check: (1) With ignition switch ON leaving engine OFF, check voltage between E139-3 and ground, E139-1 and ground. Is each voltage 10 – 14 V?	Go to Step 4.	18 and/or 21 fuse blown. If OK, faulty "B/W" wire or "BI/W" wire.
4	HO2S Heater Control Circuit check: (1) With ignition switch OFF, install HO2S heater relay. (2) With ignition switch ON leaving engine OFF, check voltage between C51-3-5 and ground. Is the voltage 10 – 14 V?	Substitute a known-good ECM (PCM) and recheck.	Faulty HO2S heater relay or "B/R" wire shorted to ground circuit. If OK, substitute a known-good ECM (PCM) and recheck.

Fig. for STEP 2, 3

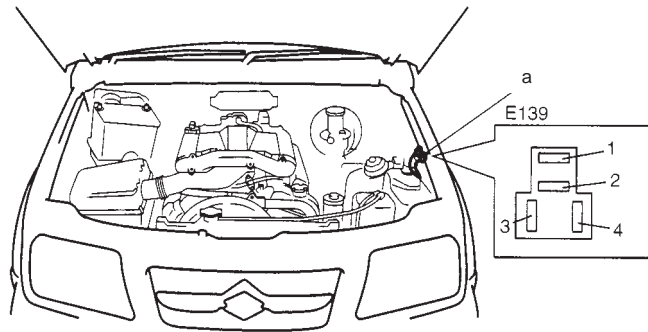

a. HO2S heater relay

## DTC P0156 HO2S (BANK-2 SENSOR-2) CIRCUIT MALFUNCTION WIRING DIAGRAM

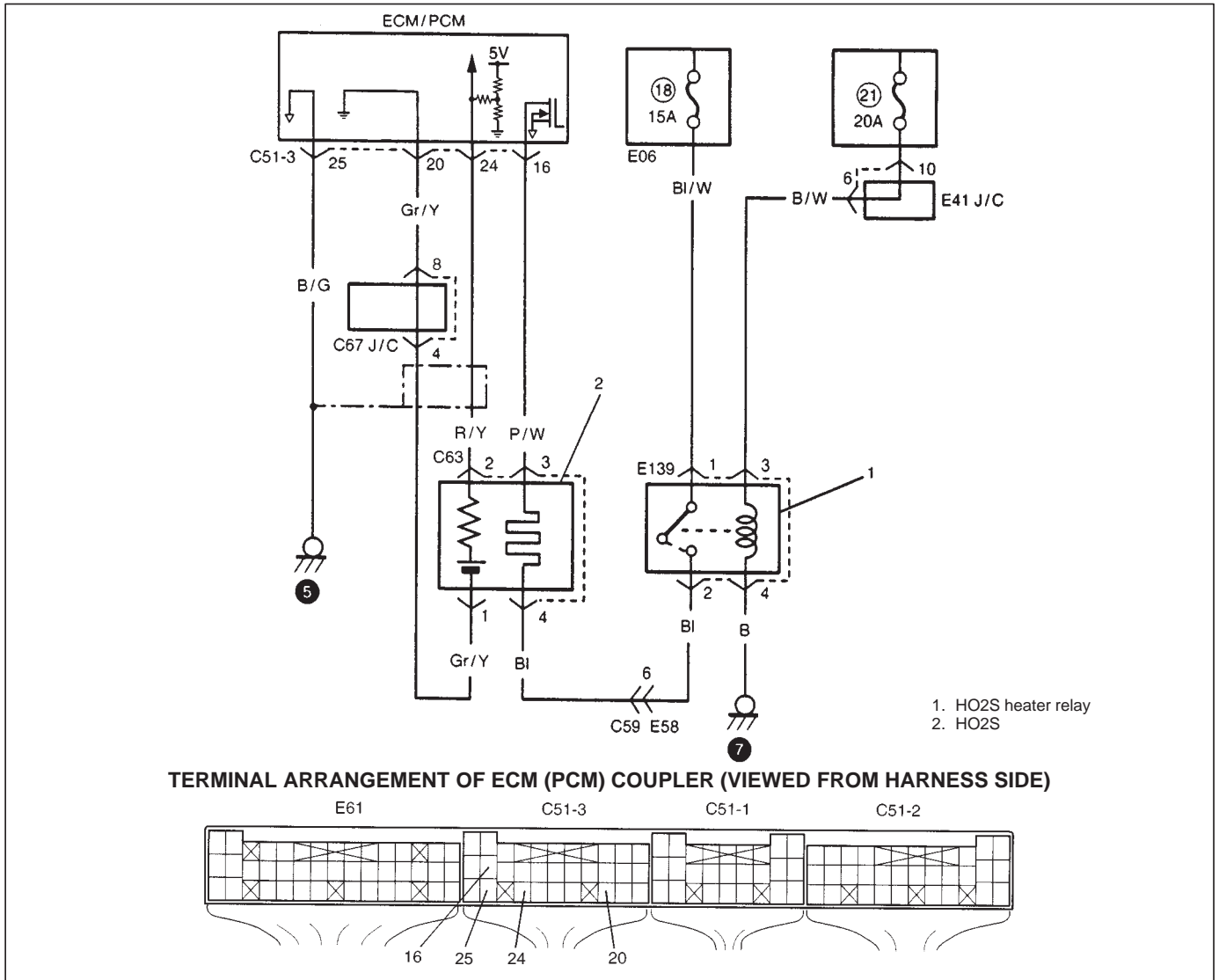

### DTC DETECTING CONDITION AND TROUBLE AREA

DTC DETECTION CONDITION	TROUBLE AREA
Maximum HO2S voltage is higher than 2.0 V for 20 sec. Maximum HO2S voltage is less than 0.35 V for 8 min. Minimum HO2S voltage is higher than 0.25 V for 4 sec. while fuel is cut.	HO2S HO2S circuit Fuel injector Fuel pressure control system ECM (PCM)

### DTC CONFIRMATION PROCEDURE

**NOTE:**

Check to make sure that following conditions are satisfied when using this DTC CONFIRMATION PROCEDURE.

**WARNING:**

- When performing a road test, select a place where there is no traffic or possibility of a traffic accident and very careful during to avoid occurrence of an accident.
- Road test, should be carried out with 2 person, a driver and tester, on a level road.

- Intake air temperature: between  $-14^{\circ}\text{C}$  and  $70^{\circ}\text{C}$  ( $6.8^{\circ}\text{F}$  and  $158^{\circ}\text{F}$ )
- Atmospheric pressure: higher than 560 mmHg (Altitude: lower than 2790 m (9150 ft))
- Following DTCs are not detected: P0110 (No.23, 25), P0335, P0460, P01450 and P01451

- (1) With ignition switch OFF, connect scan tool.
- (2) Turn ON ignition switch and clear DTC by using scan tool if any.
- (3) Start engine and warm up to normal operating temperature.
- (4) Increase vehicle speed to 56 km/h (35 mph) or more.
- (5) Keep above vehicle speed for 5 min. (Throttle valve operating is kept constant in this step.)
- (6) Increase vehicle speed to 80 – 100 km/h (50 – 60 mph). (engine speed; 2500 – 3000 r/min.)
- (7) Keep above vehicle speed for 1 min. (Throttle valve operating is kept constant in this step.)
- (8) Release accelerator pedal and with engine brake applied, keep vehicle coasting and then stop vehicle.
- (9) Check DTC and pending DTC by using scan tool.

## DTC TROUBLESHOOTING

STEP	ACTION	YES	NO
1	Was "ENGINE DIAG. FLOW TABLE" performed?	Go to Step 2.	Go to "ENGINE DIAG. FLOW TABLE".
2	HO2S Voltage check: (1) With ignition switch OFF, install scan tool. (2) Start engine and check "O2S B2 S2" (HO2S voltage) displayed on scan tool while repeating racing engine. Does the voltage deflect between 0 – 0.25 V and 0.35 – 2.0 V?	Intermittent trouble. If OK, substitute a known-good ECM (PCM) and recheck.	Go to Step 3.
3	Wire Harness check: (1) Check "R/Y" and "Gr/Y" wire. Are they in good condition?	Go to Step 4.	Repair or replace.
4	Fuel Injector Circuit check: (1) Check fuel injector circuit referring to "TABLE B-2" in this section. Is it in good condition?	Go to Step 5.	Repair or replace.
5	Fuel Injector inspection: (1) Inspect fuel injectors (No.2, 4, 6) referring to "ENGINE AND EMISSION CONTROL" section. Are they in good condition?	Go to Step 6.	Faulty fuel injector(s).
6	Fuel Pressure inspection: (1) Check fuel pressure referring to following "TABLE B-3" in this section. Is fuel pressure within specification?	Replace HO2S and recheck. If DTC P0156 detected, substitute a known-good ECM (PCM) and recheck.	Repair or replace.

**DTC P0161 HO2S (BANK-2 SENSOR-2) HEATER CIRCUIT MALFUNCTION****WIRING DIAGRAM**

Refer to DTC P0156.

**DTC DETECTING CONDITION AND TROUBLE AREA**

DTC DETECTING CONDITION	TROUBLE AREA
Current of HO2S heater is higher than specified value or lower than specified value.	HO2S HO2S circuit ECM (PCM)

**DTC CONFIRMATION PROCEDURE****NOTE:**

Check to make sure that following conditions are satisfied when using this DTC CONFIRMATION PROCEDURE.

**WARNING:**

- When performing a road test, select a place where there is no traffic or possibility of a traffic accident and very careful during to avoid occurrence of an accident.
- Road test, should be carried out with 2 person, a driver and tester, on a level road.

- Intake air temperature: between  $-14^{\circ}\text{C}$  and  $70^{\circ}\text{C}$  ( $6.8^{\circ}\text{F}$  and  $158^{\circ}\text{F}$ )
- Atmospheric pressure: higher than 560 mmHg (Altitude: lower than 2790 m (9150 ft))

- (1) With ignition switch OFF, connect scan tool.
- (2) Turn ON ignition switch and clear DTC by using scan tool if any.
- (3) Start engine and warm up to normal operating temperature.
- (4) Increase vehicle speed to 56 km/h (35 mph) or more.
- (5) Keep above vehicle speed for 5 min. (Throttle valve operating is kept constant in this step.)
- (6) Stop vehicle and run engine at idle speed for 1 min.
- (7) Check DTC and pending DTC by using scan tool.

**DTC TROUBLESHOOTING**

STEP	ACTION	YES	NO
1	Was "ENGINE DIAG. FLOW TABLE" performed?	Go to Step 2.	Go to "ENGINE DIAG. FLOW TABLE".
2	HO2S Heater check: (1) With ignition switch OFF, disconnect HO2S heater relay. (2) Check resistance between C51-3-16 and E139-2. Is the resistance 5 – 7 $\Omega$ at $20^{\circ}\text{C}$ ?	Go to Step 3.	Faulty "Bl", "P/W" wire. Faulty HO2S.
3	HO2S Heater Power Supply check: (1) With ignition switch ON leaving engine OFF, check voltage between E139-3 and ground, E139-1 and ground. Is each voltage 10 – 14 V?	Go to Step 4.	Fuse 18 and/or 21 blown. If OK, faulty "B/W" wire or "Bl/W" wire.

STEP	ACTION	YES	NO
4	HO2S Heater Control Circuit check: (1) With ignition switch OFF, install HO2S heater relay. (2) With ignition switch ON leaving engine OFF, check voltage between C51-3-16 and ground. Is the voltage 10 – 14 V?	Substitute a known-good ECM (PCM) and recheck.	Faulty HO2S heater relay or "P/W" wire shorted to ground circuit. If OK, substitute a known-good ECM (PCM) and recheck.

Fig. for STEP 2, 3

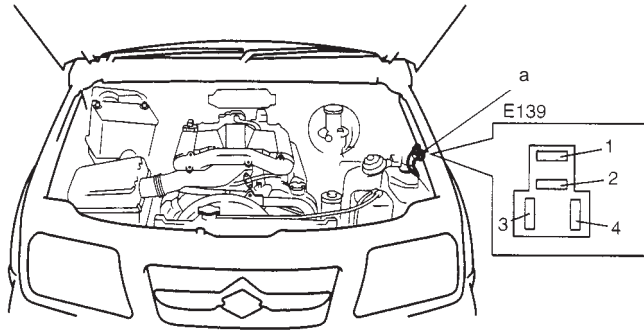

a. HO2S heater relay

**DTC P0171 FUEL SYSTEM TOO LEAN (BANK-1)**  
**DTC P0172 FUEL SYSTEM TOO RICH (BANK-1)**  
**DTC DETECTING CONDITION AND TROUBLE AREA**

DTC DETECTING CONDITION	TROUBLE AREA
<b>P0171</b> Total fuel trim of BANK-1 is higher than 33 %. <b>P0172</b> Total fuel trim of BANK-1 is lower than -33 %.	Vacuum leaks Exhaust gas leakage Fuel pressure out of specification Fuel injector malfunction Heated oxygen sensor malfunction MAF sensor malfunction ECT sensor malfunction Fuel level sensor malfunction

**DTC CONFIRMATION PROCEDURE**

**NOTE:**

Check to make sure that following conditions are satisfied when using the DTC CONFIRMATION PROCEDURE.

**WARNING:**

- When performing a road test, select a place where there is no traffic or possibility of a traffic accident and very careful during to avoid occurrence of an accident.
- Road test, should be carried out with 2 person, a driver and tester, on a level road.

- Intake air temperature: between -14°C and 70°C (6.8°F and 158°F)
- Atmospheric pressure: higher than 560 mmHg (Altitude: lower than 2790 m (9150 ft))
- Following DTCs are not detected: P0130, P0133 and P0134 (No.13)

- (1) With ignition switch OFF, connect scan tool.
- (2) Turn ON ignition switch and clear DTC by using scan tool if any.
- (3) Start engine and warm up to normal operating temperature.
- (4) Operate vehicle within freeze frame data condition as noted for 5 min.
- (5) Stop vehicle and check DTC and pending DTC by using scan tool.

**DTC TROUBLESHOOTING**

STEP	ACTION	YES	NO
1	Was "ENGINE DIAG. FLOW TABLE" performed?	Go to Step 2.	Go to "ENGINE DIAG. FLOW TABLE".
2	Is there DTC(s) other than "P0171" and "P0172"?	Go to applicable DTC FLOW TABLE.	Go to Step 3.
3	Check intake system and exhaust system for leakage. Are intake system and exhaust system in good condition?	Go to Step 4.	Repair or replace.
4	Check fuel pressure referring to "TABLE B-3" in this section. Is check result satisfactory?	Go to Step 5.	Repair or replace.
5	Check fuel injectors (No.1, 3, 5) referring to "ENGINE AND EMISSION CONTROL" section. Is check result satisfactory?	Go to Step 6.	Faulty injector(s).

STEP	ACTION	YES	NO
6	Check fuel injector circuit referring to "TABLE B-3" in this section. Is it in good condition?	Go to Step 7.	Repair or replace.
7	Check fuel level sensor referring to "ENGINE AND EMISSION CONTROL" section. Is check result satisfactory?	Go to Step 8.	Faulty fuel level sensor or its circuit.
8	Check MAF sensor referring to "ENGINE AND EMISSION CONTROL" section. Is check result satisfactory?	Go to Step 9.	Faulty MAF sensor or its circuit.
9	Check ECT sensor referring to "ENGINE AND EMISSION CONTROL" section. Is check result satisfactory?	Go to Step 10.	Faulty ECT sensor.
10	Check HO2S referring to Step 2 of DTC P0134 (DTC No.13) Diag. Flow Table. Is check result satisfactory?	Substitute a known-good ECM (PCM) and recheck.	Faulty HO2S.

**DTC P0174 FUEL SYSTEM TOO LEAN (BANK-2)**  
**DTC P0175 FUEL SYSTEM TOO RICH (BANK-2)**  
**DTC DETECTING CONDITION AND TROUBLE AREA**

DTC DETECTING CONDITION	TROUBLE AREA
<b>P0174</b> Total fuel trim of BANK-2 is higher than 33 %. <b>P0175</b> Total fuel trim of BANK-2 is lower than -33 %.	Vacuum leaks Exhaust gas leakage Fuel pressure out of specification Fuel injector malfunction Heated oxygen sensor malfunction MAF sensor malfunction ECT sensor malfunction Fuel level sensor malfunction

**DTC CONFIRMATION PROCEDURE**

**NOTE:**

Check to make sure that following conditions are satisfied when using the DTC CONFIRMATION PROCEDURE.

**WARNING:**

- When performing a road test, select a place where there is no traffic or possibility of a traffic accident and very careful during to avoid occurrence of an accident.
- Road test, should be carried out with 2 person, a driver and tester, on a level road.

- Intake air temperature: between -14°C and 70°C (6.8°F and 158°F)
- Atmospheric pressure: higher than 560 mmHg (Altitude: lower than 2790 m (9150 ft))
- Following DTCs are not detected: P0130, P0133 and P0134 (No.13)

- (1) With ignition switch OFF, connect scan tool.
- (2) Turn ON ignition switch and clear DTC by using scan tool if any.
- (3) Start engine and warm up to normal operating temperature.
- (4) Operate vehicle within freeze frame data condition as noted for 5 min.
- (5) Stop vehicle and check DTC and pending DTC by using scan tool.

**DTC TROUBLESHOOTING**

STEP	ACTION	YES	NO
1	Was "ENGINE DIAG. FLOW TABLE" performed?	Go to Step 2.	Go to "ENGINE DIAG. FLOW TABLE".
2	Is there DTC(s) other than "P0174" and "P0175"?	Go to applicable DTC FLOW TABLE.	Go to Step 3.
3	Check intake system and exhaust system for leakage. Are intake system and exhaust system in good condition?	Go to Step 4.	Repair or replace.
4	Check fuel pressure referring to "TABLE B-3" in this section. Is check result satisfactory?	Go to Step 5.	Repair or replace.
5	Check fuel injectors (No. 2, 4, 6) referring to "ENGINE AND EMISSION CONTROL" section. Is check result satisfactory?	Go to Step 6.	Faulty injector(s).

STEP	ACTION	YES	NO
6	Check fuel injector circuit referring to "TABLE B-3" in this section. Is it in good condition?	Go to Step 7.	Repair or replace.
7	Check fuel level sensor referring to "ENGINE AND EMISSION CONTROL" section. Is check result satisfactory?	Go to Step 8.	Faulty fuel level sensor or its circuit.
8	Check MAF sensor referring to "ENGINE AND EMISSION CONTROL" section. Is check result satisfactory?	Go to Step 9.	Faulty MAF sensor or its circuit.
9	Check ECT sensor referring to "ENGINE AND EMISSION CONTROL" section. Is check result satisfactory?	Go to Step 10.	Faulty ECT sensor.
10	Check HO2S referring to Step 2 of DTC P0154 (DTC No.26) Diag. Flow Table. Is check result satisfactory?	Substitute a known-good ECM (PCM) and recheck.	Faulty HO2S.

**DTC P0300 RANDOM MISFIRE DETECTED**  
**DTC P0301 CYLINDER 1 MISFIRE DETECTED**  
**DTC P0302 CYLINDER 2 MISFIRE DETECTED**  
**DTC P0303 CYLINDER 3 MISFIRE DETECTED**  
**DTC P0304 CYLINDER 4 MISFIRE DETECTED**  
**DTC P0305 CYLINDER 5 MISFIRE DETECTED**  
**DTC P0306 CYLINDER 6 MISFIRE DETECTED**

### SYSTEM DESCRIPTION

ECM (PCM) measure the angle of the crankshaft based on the pulse signal from the CKP sensor and CMP sensor for each cylinder. If it detects a large change in the angle speed of the crankshaft, it concludes occurrence of a misfire. When the number of misfire is counted by ECM (PCM) beyond the DTC detecting condition, it determine the cylinder where the misfire occurred and output it as DTC.

### DTC DETECTING CONDITION AND TROUBLE AREA

DTC DETECTING CONDITION	TROUBLE AREA
<p><b>P0300</b>  Misfire, which causes catalyst to overheat during 200 engine revolutions, is detected at 2 or more cylinders. (MIL flashes as long as this misfire occurs continuously.)  Misfire, which affects exhaust emission adversely during 1000 engine revolution, is detected at 2 or more cylinders.</p>	<p>Ignition system  Fuel injector and its circuit  Fuel pressure  EGR system  Fuel level sensor  Abnormal air drawn in</p>
<p><b>P0301, P0302, P0303, P0304, P0305, P0306</b>  Misfire, which causes catalyst to overheat during 200 engine revolutions, is detected at 1 cylinder. (MIL flashes as long as this misfire occurs continuously.)  Misfire, which affects exhaust emission adversely during 1000 engine revolution, is detected at 1 cylinder.</p>	<p>Engine compression  Valve lash adjuster  Valve timing</p>

### DTC CONFIRMATION PROCEDURE

#### NOTE:

**Check to make sure that following conditions are satisfied when using this DTC CONFIRMATION PROCEDURE.**

#### WARNING:

- When performing a road test, select a place where there is no traffic or possibility of a traffic accident and very careful during to avoid occurrence of an accident.
- Road test, should be carried out with 2 person, a driver and tester, on a level road.

- Intake air temperature: between  $-14^{\circ}\text{C}$  and  $70^{\circ}\text{C}$  ( $6.8^{\circ}\text{F}$  and  $158^{\circ}\text{F}$ )
- Atmospheric pressure: higher than 560 mmHg (Altitude: lower than 2790 m (9150 ft))
- Following DTCs are not detected: P0335 and P0340 (No.42)

- (1) With ignition switch OFF, connect scan tool.
- (2) Turn ON ignition switch and clear DTC by using scan tool if any.
- (3) Operate vehicle within freeze frame data condition as noted for 1 min.
- (4) Stop vehicle and check DTC and pending DTC by using scan tool.

**DTC TROUBLESHOOTING**

STEP	ACTION	YES	NO
1	Was "ENGINE DIAG. FLOW TABLE" performed?	Go to Step 2.	Go to "ENGINE DIAG. FLOW TABLE".
2	Ignition System inspection: (1) Check spark plug and ignition spark of cylinder where misfire occurs, referring to "IGNITION SYSTEM" section. Is it in good condition?	Go to Step 3.	Faulty ignition coil, wire harness or spark plug. If OK, substitute a known-good ECM (PCM) and recheck.
3	Fuel Injector Circuit check: (1) Check fuel injector circuit referring to "TABLE B-2" in this section. Is it in good condition?	Go to Step 4.	Repair or replace.
4	Fuel Injector Operation check: (1) Using sound scope, check each injector operating sound at engine cranking or idling. Do all injectors make operating sound?	Go to Step 5.	Check injector not making operating sound. If OK, substitute a known-good ECM (PCM) and recheck.
5	Fuel Pressure inspection: (1) Check fuel pressure referring to "TABLE B-3" in this section. Is check result satisfactory?	Go to Step 6.	Repair or replace.
6	Fuel Injector inspection: (1) Check fuel injector(s) referring to "ENGINE AND EMISSION CONTROL SYSTEM" section. Is check result satisfactory?	Go to Step 7.	Replace.
7	Ignition Timing inspection: (1) Check ignition timing referring to "IGNITION SYSTEM" section. Is check result satisfactory?	Go to Step 8.	Adjust.
8	EGR System inspection: (1) Check EGR system referring to "ENGINE AND EMISSION CONTROL SYSTEM" section. Is check result satisfactory?	Go to Step 9.	Repair or replace.
9	Fuel Level Sensor inspection: (1) Check fuel level sensor referring to "ENGINE AND EMISSION CONTROL SYSTEM" section. Is check result satisfactory?	Go to Step 10.	Repair or replace.
10	Engine Mechanical Systems check: (1) Check engine mechanical systems referring to "ENGINE MECHANICAL" section. Is check result satisfactory?	Substitute a known-good ECM (PCM) and recheck.	Repair or replace.

## DTC P0335 CRANKSHAFT POSITION SENSOR CIRCUIT MALFUNCTION WIRING DIAGRAM

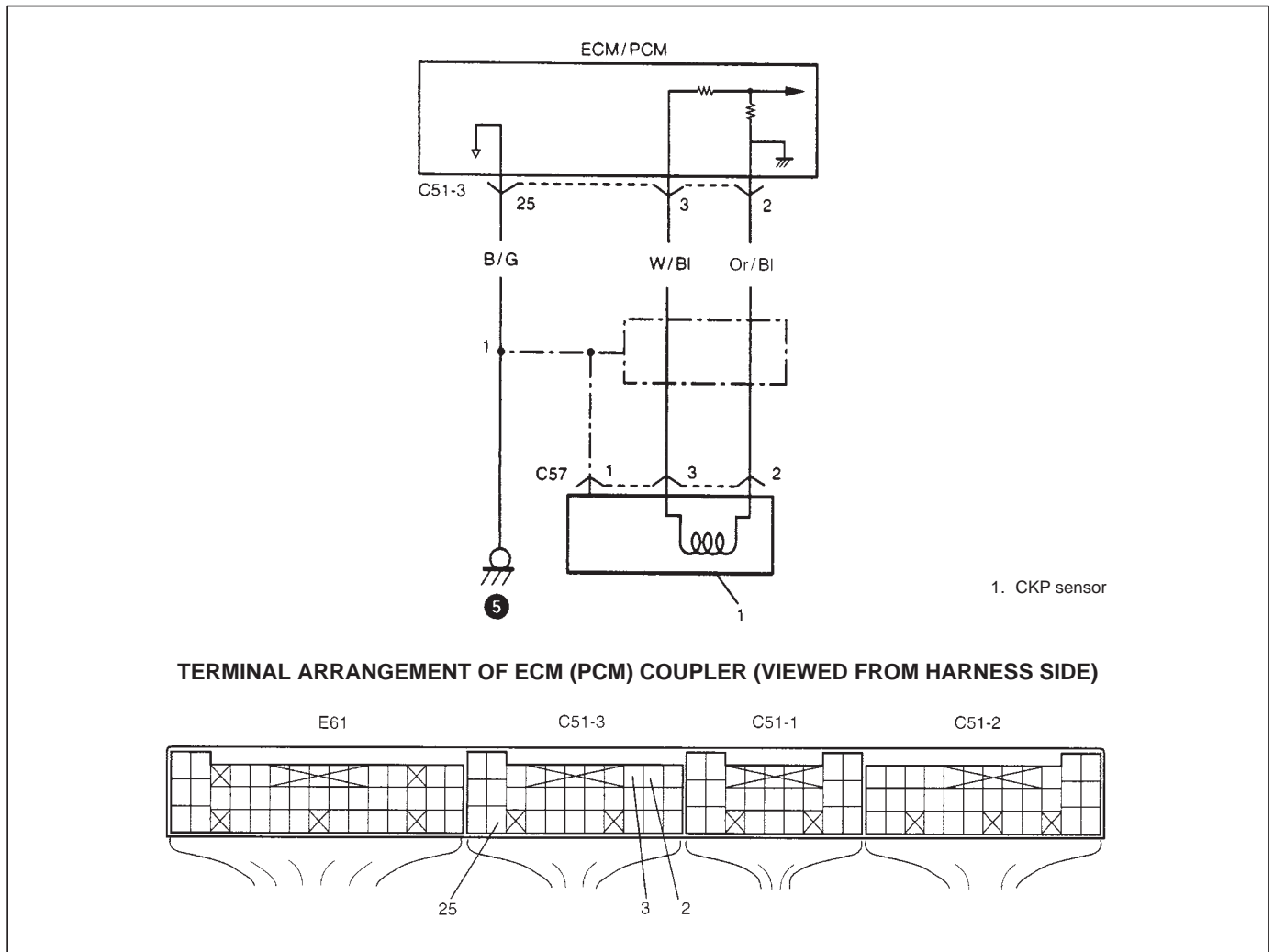

### DTC DETECTING CONDITION AND TROUBLE AREA

DTC DETECTING CONDITION	TROUBLE AREA
CKP sensor signal is not input for 3 sec. after engine start.	CKP sensor CKP sensor circuit ECM (PCM)

### DTC CONFIRMATION PROCEDURE

#### NOTE:

Check to make sure that following conditions are satisfied when using this DTC CONFIRMATION PROCEDURE.

- Intake air temperature: between  $-14^{\circ}\text{C}$  and  $70^{\circ}\text{C}$  ( $6.8^{\circ}\text{F}$  and  $158^{\circ}\text{F}$ )
- Atmospheric pressure: higher than 560 mmHg (Altitude: lower than 2790 m (9150 ft))
- Following DTC is not detected: P0340 (No.42)

- (1) With ignition switch OFF, connect scan tool.
- (2) Turn ON ignition switch and clear DTC by using scan tool if any.
- (3) Start engine and run it for 10 sec.
- (4) Check DTC by using scan tool.

## DTC TROUBLESHOOTING

STEP	ACTION	YES	NO
1	Was "ENGINE DIAG. FLOW TABLE" performed?	Go to Step 2.	Go to "ENGINE DIAG. FLOW TABLE".
2	CKP Sensor and Its Circuit Resistance check: (1) With ignition switch OFF, disconnect ECM (PCM) coupler (C51-3). (2) Check resistance between C51-3-2 and C51-3-3. Is the resistance 484 – 656 $\Omega$ ?	Go to Step 4.	Go to Step 3.
3	CKP Sensor Resistance check: (1) With ignition switch OFF, disconnect CKP sensor coupler. (2) Check resistance between "2" and "3" terminal of CKP sensor coupler. Is the resistance 485 – 655 $\Omega$ ?	Faulty "W/BI" wire or "Or/B" wire.	Faulty CKP sensor.
4	CKP Sensor Visual inspection: (1) Check CKP sensor installation and teeth of crankshaft referring to "ENGINE MECHANICAL" section. Are they OK?	Poor C51-3-2 and/or C51-3-3 terminal of ECM (PCM) coupler connection. "W/BI" wire or "Or/BI" wire shorted to other circuit. If OK, substitute a known-good ECM (PCM) and recheck.	Replace or reinstall.

Fig. for STEP 3

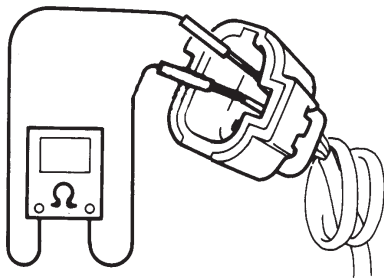

## DTC P0340 CAMSHAFT POSITION SENSOR CIRCUIT MALFUNCTION (DTC No.42)

### WIRING DIAGRAM

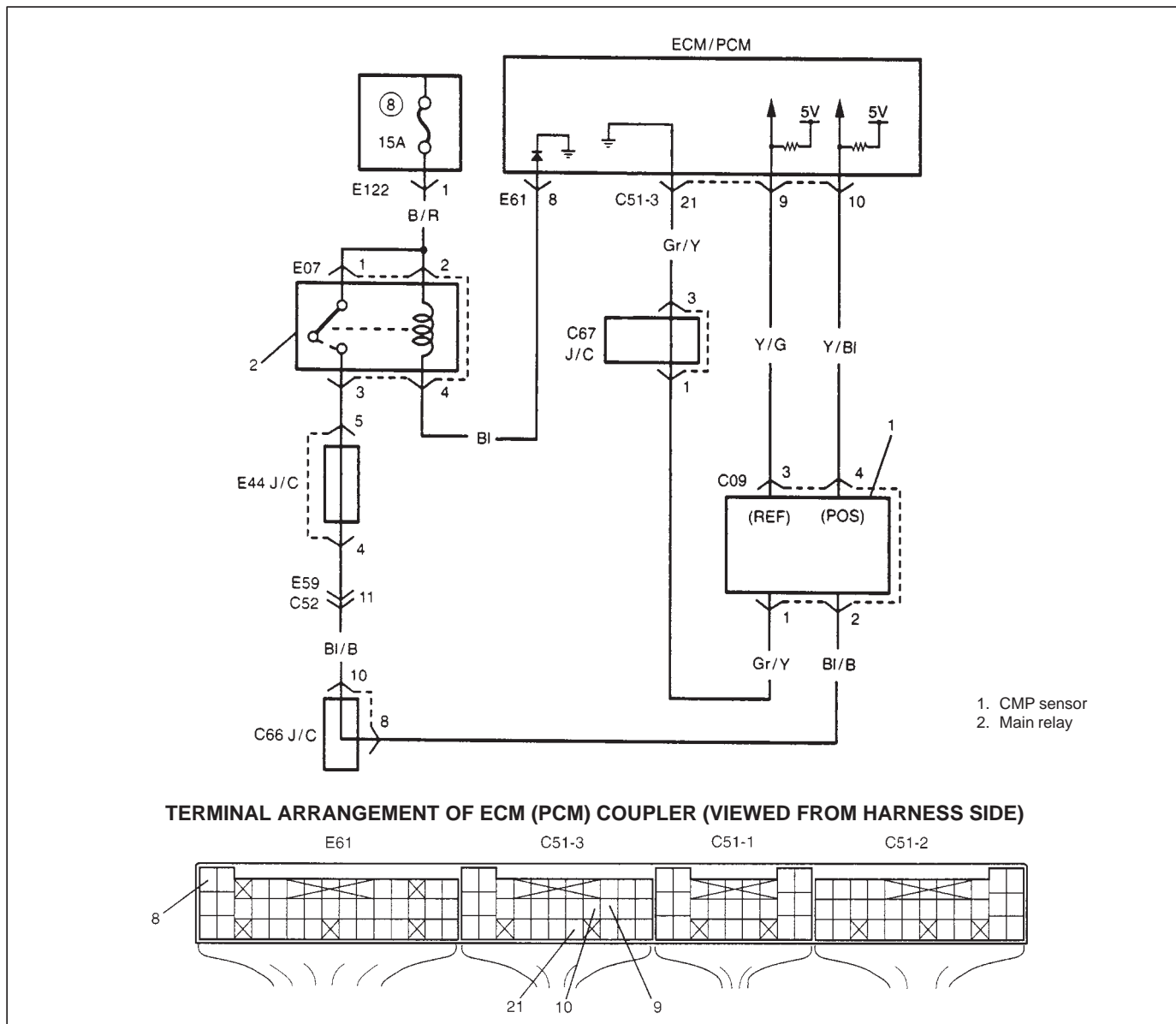

### SYSTEM DESCRIPTION

CMP sensor detects REF signal and POS signal.

- **REF signal:** 6 pulses/1 revolution of camshaft. Each of REF signals has different wavelength. Based on REF signal, ECM (PCM) judges which cylinder is at TDC.
- **POS signal:** 360 pulses/1 revolution of camshaft. Each of POS signals has equivalent wavelength. Based on POS signal, ECM (PCM) judges the wavelength of REF signals, engine speed and piston position.

### DTC DETECTING CONDITION AND TROUBLE AREA

DTC DETECTING CONDITION	TROUBLE AREA
Engine start signal is input but CMP sensor signal is not input for 5 sec. CMP sensor signal is input less than 10 while 2 CKP sensor signal is input.	CMP sensor CMP sensor circuit Engine start signal circuit ECM (PCM)

**DTC CONFIRMATION PROCEDURE****NOTE:**

Check to make sure that following conditions are satisfied when using this DTC CONFIRMATION PROCEDURE.

- Intake air temperature: between  $-14^{\circ}\text{C}$  and  $70^{\circ}\text{C}$  ( $6.8^{\circ}\text{F}$  and  $158^{\circ}\text{F}$ )
- Atmospheric pressure: higher than 560 mmHg (Altitude: lower than 2790 m (9150 ft))
- Following DTC is not detected: P0335

- (1) With ignition switch OFF, connect scan tool.
- (2) Turn ON ignition switch and clear DTC by using scan tool if any.
- (3) Crank engine for 8 sec.
- (4) Check DTC by using scan tool.

**DTC TROUBLESHOOTING**

STEP	ACTION	YES	NO
1	Was "ENGINE DIAG. FLOW TABLE" performed?	Go to Step 2.	Go to "ENGINE DIAG. FLOW TABLE".
2	Is engine cranked?	Go to Step 3.	Go to "CRANKING SYSTEM" section.
3	Engine Start Signal check: (1) Check engine start signal circuit referring to "DTC P1500" in this section. Is the result satisfactory?	Go to Step 4.	Repair or replace.
4	CMP Sensor Power Supply Voltage check: (1) With ignition switch OFF, disconnect CMP sensor coupler (1). (2) With ignition switch ON, check voltage between C09-2 and C09-1 terminal. Is the voltage 10 – 14 V?	Go to Step 5.	Faulty "BI/B" wire and/or "Gr/Y" wire.
5	CMP Sensor (REF) Signal check: (1) With ignition switch OFF, connect CMP sensor coupler (1). (2) Disconnect couplers from ignition coil assembly and fuel injectors. (3) With ignition switch ON and crankshaft turned slowly, check voltage between C51-3-10 and C51-3-21. Does voltmeter indicator deflect between 0 – 1 V and 4 – 6 V 6 times while crankshaft turned two revolutions?	Go to Step 6.	Faulty "Y/BI" wire or CMP sensor. If OK, substitute a known-good ECM (PCM) and recheck.
6	CMP Sensor (POS) Signal check: (1) With ignition switch ON and crankshaft turned slowly, check voltage between C51-3-9 and C51-3-21. Does voltmeter indicator deflect between 0 – 1 V and 4 – 6 V?	Poor C51-3-9 and/or C51-3-10 terminal of ECM (PCM) coupler connection. If OK, substitute a known-good ECM (PCM) and recheck.	Faulty "Y/G" wire or CMP sensor. If OK, substitute a known-good ECM (PCM) and recheck.

Fig. for STEP 4

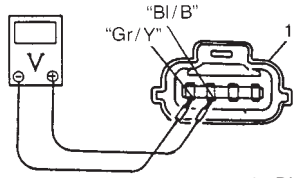

1. Disconnected  
CMP sensor coupler
2. "BI/B" wire terminal
3. "Gr/Y" wire terminal

# DTC P0400 EXHAUST GAS RECIRCULATION FLOW MALFUNCTION (DTC No.51)

## SYSTEM/WIRING DIAGRAM

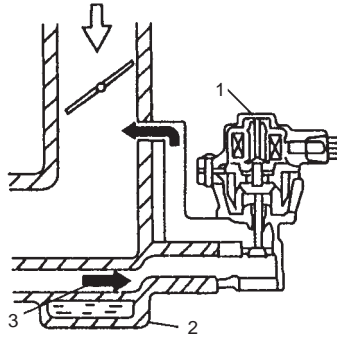

- 1. EGR valve
- 2. Intake manifold
- 3. Exhaust gas

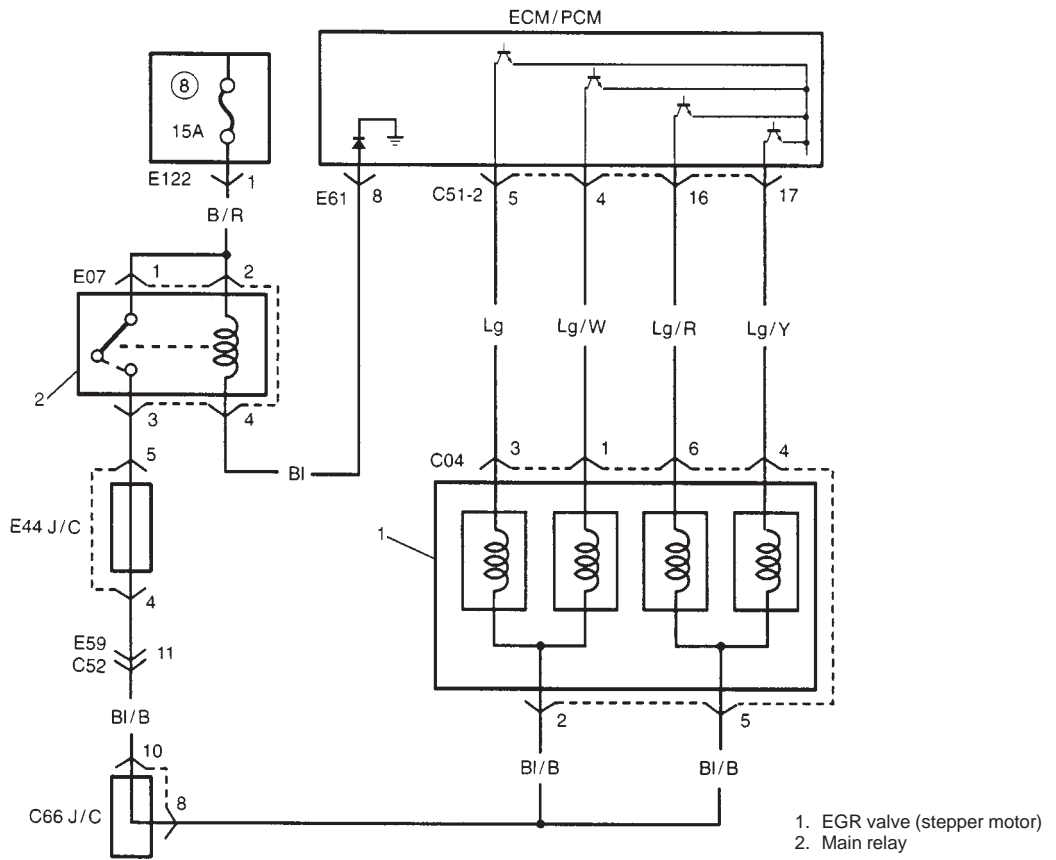

- 1. EGR valve (stepper motor)
- 2. Main relay

### TERMINAL ARRANGEMENT OF ECM (PCM) COUPLER (VIEWED FROM HARNESS SIDE)

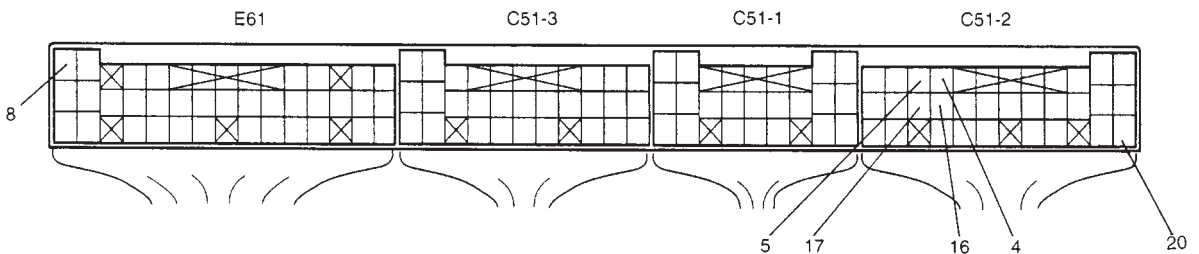

**SYSTEM DESCRIPTION**

EGR system consists of EGR valve and its passage. ECM (PCM) judges EGR valve opening based on following items. (engine speed, engine load, engine coolant temperature, intake air temperature and vehicle speed)

If EGR system is in good condition, intake manifold absolute pressure is varied within specified value as soon as ECM (PCM) opens EGR valve.

**DTC DETECTING CONDITION AND TROUBLE AREA**

DTC DETECTING CONDITION	TROUBLE AREA
The difference of intake manifold absolute pressure before and after EGR valve is opened is out of specification.	EGR valve EGR circuit EGR system MAP sensor ECM (PCM)

**DTC CONFIRMATION PROCEDURE****NOTE:**

Check to make sure that following conditions are satisfied when using this DTC CONFIRMATION PROCEDURE.

**WARNING:**

- When performing a road test, select a place where there is no traffic or possibility of a traffic accident and very careful during to avoid occurrence of an accident.
- Road test, should be carried out with 2 person, a driver and tester, on a level road.

- Intake air temperature: between  $-14^{\circ}\text{C}$  and  $70^{\circ}\text{C}$  ( $6.8^{\circ}\text{F}$  and  $158^{\circ}\text{F}$ )
- Atmospheric pressure: higher than 560 mmHg (Altitude: lower than 2790 m (9150 ft))
- Following DTC is not detected: P1408

- (1) With ignition switch OFF, connect scan tool.
- (2) Turn ON ignition switch and clear DTC by using scan tool if any.
- (3) Start engine and warm up to normal operating temperature.
- (4) Increase vehicle speed to 50 – 65 km/h (30 – 40 mph) (engine speed; 2000 – 3000 r/min.).
- (5) Keep above vehicle speed for 3 min. (Throttle valve operating is kept constant in this step.)
- (6) Stop vehicle and check DTC and pending DTC by using scan tool.

**DTC TROUBLESHOOTING**

STEP	ACTION	YES	NO
1	Was "ENGINE DIAG. FLOW TABLE" performed?	Go to Step 2.	Go to "ENGINE DIAG. FLOW TABLE".
2	Do you have SUZUKI scan tool?	Go to Step 3.	Go to Step 4.
3	EGR Valve Operation check: (1) With ignition switch OFF, install SUZUKI scan tool. (2) Check EGR system referring to "ENGINE AND EMISSION CONTROL" section. Is it in good condition?	Intermittent trouble. If OK, substitute a known-good ECM (PCM) and recheck.	Go to Step 4.
4	EGR Valve Power Supply Circuit check: (1) With ignition switch OFF, disconnect EGR valve coupler (1). (2) With ignition switch ON, check voltage between C04-2 (b) and ground, C04-5 (e) and ground. Is each voltage 10 – 14 V?	Go to Step 5.	Faulty "BI/B" wire.

STEP	ACTION	YES	NO
5	<p>EGR Valve Stepper Motor Coil Circuit check:</p> <p>(1) With ignition switch OFF, connect EGR coupler and disconnect ECM (PCM) couplers.</p> <p>(2) Check resistance between C51-2-20 and C51-2-4, C51-2-5, C51-2-16, C51-2-17.</p> <p>Is each resistance 20 – 24 <math>\Omega</math>?</p>	<p>Stuck or faulty EGR valve.</p> <p>Clogged EGR gas passage.</p> <p>MAP sensor malfunction.</p> <p>If OK, substitute a known-good ECM (PCM) and recheck.</p>	<p>Faulty "Lg", "Lg/W", "Lg/R", "Lg/Y" wire or EGR valve.</p>

Fig. for STEP 4

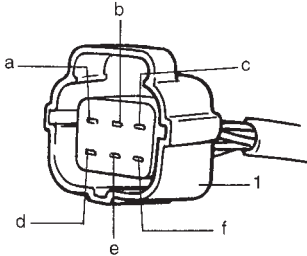
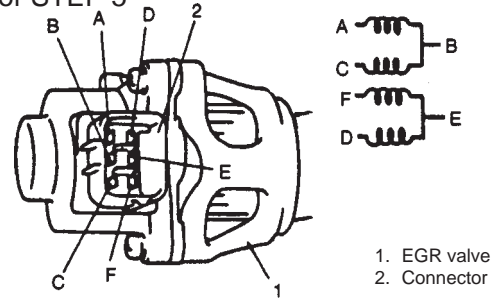
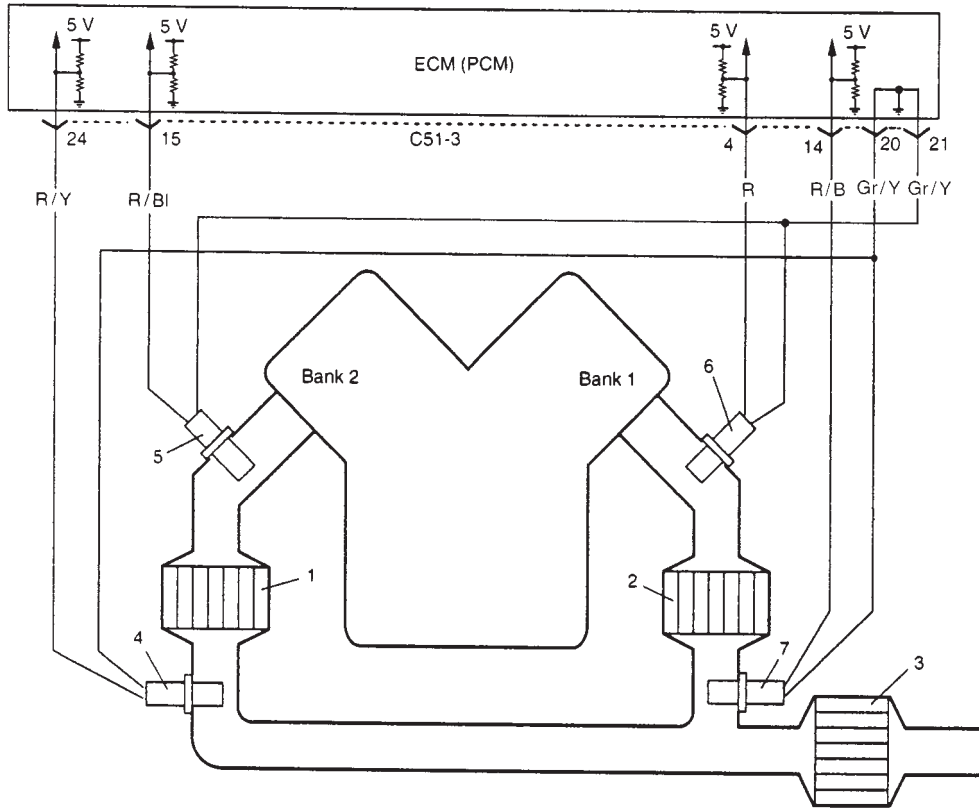

Fig. for STEP 5



**DTC P0420 CATALYST SYSTEM (BANK-1) EFFICIENCY BELOW THRESHOLD  
 DTC P0430 CATALYST SYSTEM (BANK-2) EFFICIENCY BELOW THRESHOLD  
 SYSTEM/WIRING DIAGRAM**



- |                                   |                            |
|-----------------------------------|----------------------------|
| 1. Warm up TWC converter (Bank 2) | 5. HO2S (Bank 2, Sensor 1) |
| 2. Warm up TWC converter (Bank 1) | 6. HO2S (Bank 1, Sensor 1) |
| 3. TWC converter                  | 7. HO2S (Bank 1, Sensor 2) |
| 4. HO2S (Bank 2, Sensor 2)        |                            |

**TERMINAL ARRANGEMENT OF ECM (PCM) COUPLER (VIEWED FROM HARNESS SIDE)**

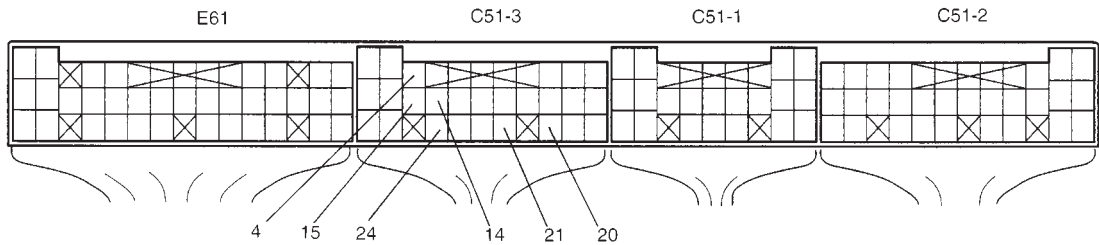

**SYSTEM DESCRIPTION**

Exhaust oxygen concentration at the upper part and the lower part of TWC is detected from HO2S-1 and HO2S-2 respectively and accordingly ECM (PCM) controls the closed loop which then controls the fuel injection volume. While the above control is going on and if TWC is in good condition, the output voltage of HO2S-2 is maintained at specified level. As TWC is in becomes deteriorated, even when the above control is going on, the exhaust gas which has passed TWC then passes HO2S-2 at the exhaust oxygen concentration similar to that of the upper part of TWC without being oxygenated or converted. Thus, waveforms of HO2S-1 and HO2S-2 output voltage become alike. ECM (PCM) judges deterioration of TWC by comparing waveforms of HO2S-1 and HO2S-2.

**DTC DETECTING CONDITION AND TROUBLE AREA**

DTC DETECTING CONDITION	TROUBLE AREA
Output waveform of HO2S (S-2) becomes similar to that of HO2S (S-1).	TWC converter Exhaust system HO2S (SENSOR 2) HO2S (SENSOR 2) circuit ECM (PCM)

**DTC CONFIRMATION PROCEDURE****NOTE:**

Check to make sure that following conditions are satisfied when using this DTC CONFIRMATION PROCEDURE.

**WARNING:**

- When performing a road test, select a place where there is no traffic or possibility of a traffic accident and very careful during to avoid occurrence of an accident.
- Road test, should be carried out with 2 person, a driver and tester, on a level road.

- Intake air temperature: between  $-14^{\circ}\text{C}$  and  $70^{\circ}\text{C}$  ( $6.8^{\circ}\text{F}$  and  $158^{\circ}\text{F}$ )
- Atmospheric pressure: higher than 560 mmHg (Altitude: lower than 2790 m (9150 ft))
- Following DTCs are not detected: P0100 (No.33, 34), P0110 (No.23, 25), P0115 (No.14, 15), P0130, P0133, P0134 (No.13), P0135, P0136, P0141, P0335, P0460, P0500 (No.24), P1450 and P1451

- (1) With ignition switch OFF, connect scan tool.
- (2) Turn ON ignition switch and clear DTC by using scan tool if any.
- (3) Start engine and warm up to normal operating temperature.
- (4) Increase vehicle speed to 56 km/h (35 mph) or more.
- (5) Keep above vehicle speed for 5 min. (Throttle valve operating is kept constant in this step.)
- (6) Increase vehicle speed to 80 – 100 km/h (50 – 60 mph). (engine speed; 2500 – 3000 r/min.)
- (7) Keep above vehicle speed for 1 min. (Throttle valve operating is kept constant in this step.)
- (8) Stop vehicle and check DTC and pending DTC by using scan tool.

**DTC TROUBLESHOOTING**

STEP	ACTION	YES	NO
1	Was "ENGINE DIAG. FLOW TABLE" performed?	Go to Step 2.	Go to "ENGINE DIAG. FLOW TABLE".
2	Exhaust System Visual inspection: (1) Check exhaust system for leaks, damage and loose. Is it in good condition?	Go to Step 3.	Repair or replace.
3	HO2S BANK-1 (BANK-2) SENSOR-2 Circuit check: (1) Check "R/B" and "Gr/Y" wire ("R/Y" and "Gr/Y" wire). Are they in good condition?	Go to Step 4.	Repair or replace.
4	(1) Replace BANK-1 (BANK-2) HO2S SENSOR-2. (2) Perform DTC confirmation procedure. Is DTC P0420 (P0430) detected?	Go to Step 5.	Faulty BANK-1 (BANK-2) HO2S SENSOR-2.
5	(1) Replace BANK-1 (BANK-2) warm up TWC converter. (2) Perform DTC confirmation procedure. Is DTC P0420 (P0430) detected?	Substitute a known-good ECM (PCM) and recheck.	Replace TWC converter.

## DTC P0443 EVAP CONTROL SYSTEM PURGE CONTROL VALVE CIRCUIT MALFUNCTION WIRING DIAGRAM

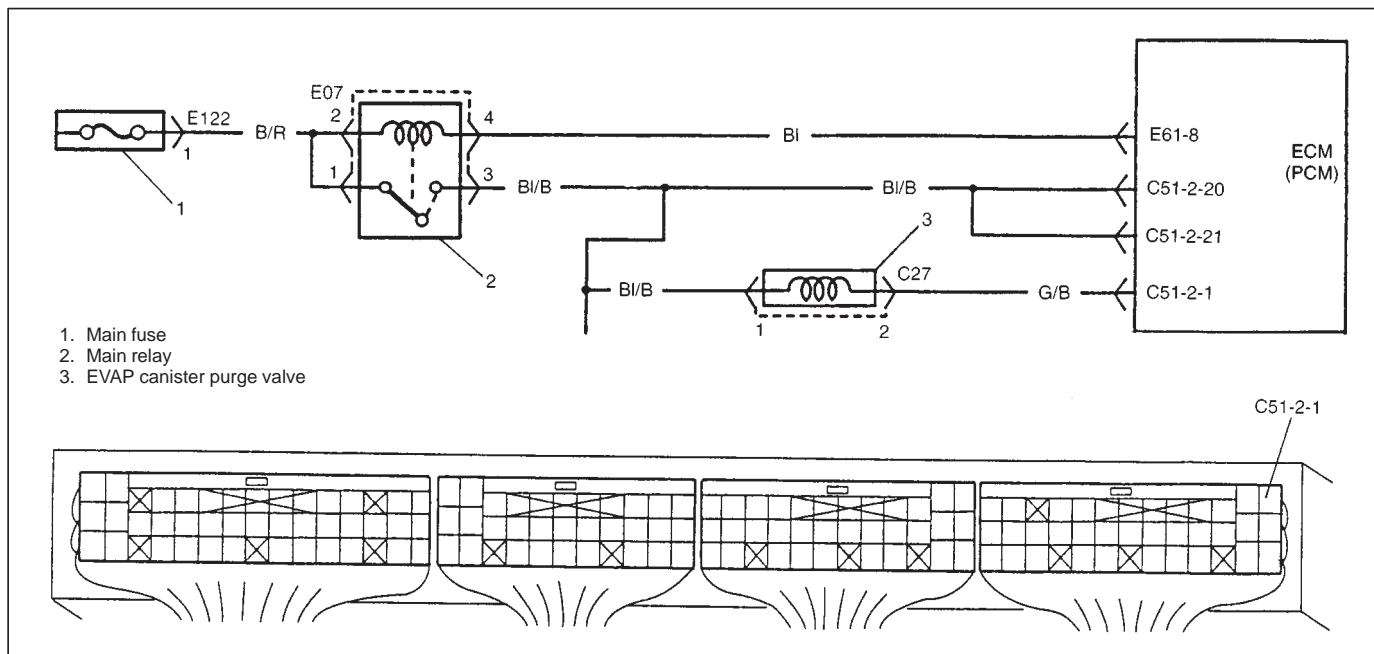

### DTC DETECTING CONDITION AND TROUBLE AREA

DTC DETECTING CONDITION	TROUBLE AREA
Monitor signal of EVAP canister purge valve is different from command signal. (Circuit open or short) (2 driving cycle detection logic)	<ul style="list-style-type: none"> <li>● EVAP canister purge valve and its circuit</li> <li>● ECM (PCM)</li> </ul>

### DTC CONFIRMATION PROCEDURE

#### WARNING:

- When performing a road test, select a place where there is no traffic or possibility of a traffic accident and be very careful during testing to avoid occurrence of an accident.
- Road test should be carried out with 2 persons, a driver and a tester, on a level road.

#### NOTE:

Check to make sure that the following conditions are satisfied when using this DTC CONFIRMATION PROCEDURE.

- Intake air temperature: between  $-14^{\circ}\text{C}$  and  $70^{\circ}\text{C}$  ( $6.8^{\circ}\text{F}$  and  $158^{\circ}\text{F}$ )
- Atmospheric pressure: higher than 560 mmHg (Altitude: lower than 2790 m (9150 ft))

- 1) Connect scan tool to DLC with ignition switch OFF.
- 2) Turn ON ignition switch and clear DTC, pending DTC and freeze frame data by using scan tool.
- 3) Start engine and warm up it completely.
- 4) Increase vehicle speed to 40 km/h (25 mph) or more.
- 5) Keep driving above vehicle speed for 5 min. or more (Change of vehicle speed is permitted in this step).
- 6) Release accelerator pedal, stop vehicle and run engine at idle speed for 2 min.
- 7) Check DTC and pending DTC by using scan tool.

**TROUBLESHOOTING (DTC P0443)**

STEP	ACTION	YES	NO
1	Was "ENGINE DIAG. FLOW TABLE" performed?	Go to Step 2.	Go to "ENGINE DIAG. FLOW TABLE".
2	Check EVAP canister purge system for operation referring to "EVAP Canister Purge System" check. Is check result satisfactory?	Intermittent trouble or faulty ECM (PCM). Check for intermittent referring to "Intermittent and Poor Connection" in Section 0A.	Go to Step 3.
3	Check EVAP canister purge valve for resistance referring to "EVAP Canister Purge Valve" and its circuit check. Is resistance as specified?	"G/B" or "BI/B" circuit open or short. If wire and connections are OK, substitute a known-good ECM (PCM) and recheck.	Replace EVAP canister purge valve.

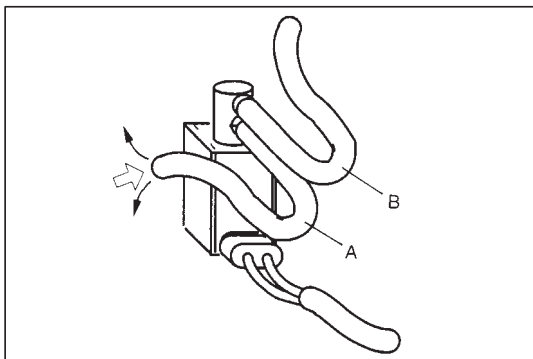

### EVAP Canister Purge Valve and Its Circuit Check.

- 1) Disconnect vacuum hoses from vacuum pipes.
- 2) With ignition switch ON, blow into hose "A". Air should not come out of hose "B".

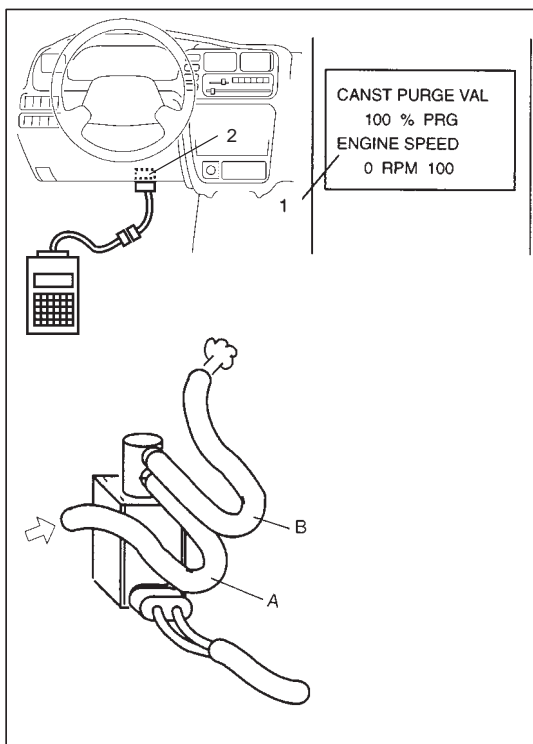

### Using SUZUKI scan tool

- 3) Connect SUZUKI scan tool (1) to DLC (2) with ignition switch OFF.
- 3-1) Turn ON EVAP canister purge valve by using SUZUKI scan tool with ignition switch ON.  
In this state, blow hose "A".  
Air should come out of hose "B".

#### **WARNING:**

**Do not suck the air through valve. Fuel vapor inside valve is harmful.**

If check results are as described above, EVAP canister purge valve and its circuit are in good condition, connect vacuum hoses securely.

If not, proceed to step 4).

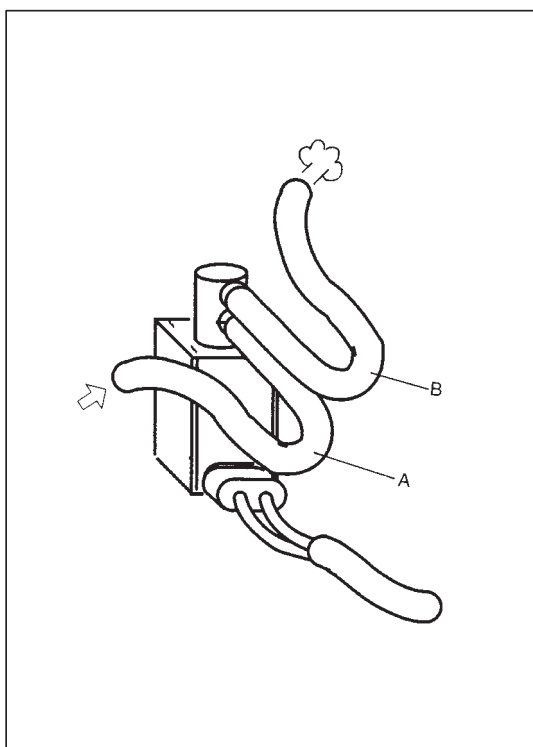

### Not using SUZUKI scan tool

- 3) Using service wire, connect C51-2-1 terminal of ECM (PCM) coupler and body ground with ignition switch OFF.
- 3-1) Turn ON ignition switch.  
In this state, blow hose "A".  
Air should come out of hose "B".

#### **WARNING:**

**Do not suck the air through valve. Fuel vapor inside valve is harmful.**

If check results are as described above and C51-2-1 terminal to ECM connection is OK, EVAP canister purge valve and its circuit are in good condition, connect vacuum hoses securely.

If not, proceed to step 4).

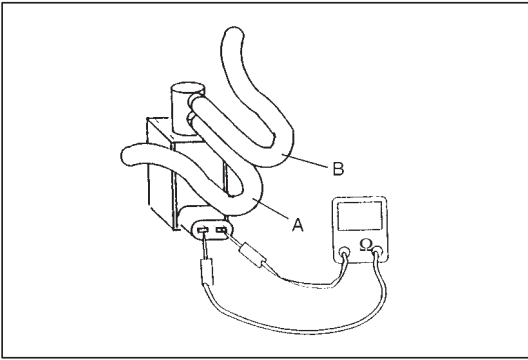

- 4) With ignition switch OFF, disconnect coupler from EVAP canister purge valve.
- 5) Check resistance between two terminals of EVAP canister purge valve.

**Resistance of EVAP canister purge valve:**  
**28 – 36  $\Omega$  at 20°C (68°F)**

If resistance is as specified, proceed to next operation check.  
 If not, replace.

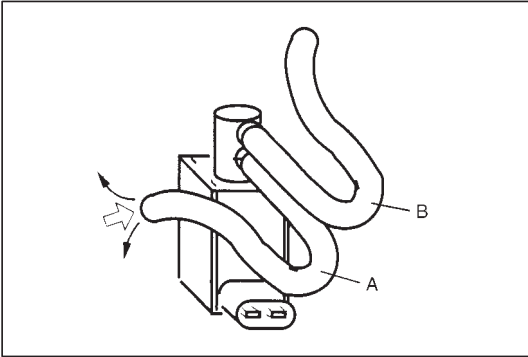

- 6) With coupler disconnected, blow into hose "A". Air should not come out of hose "B".  
 If not, replace EVAP canister purge valve.

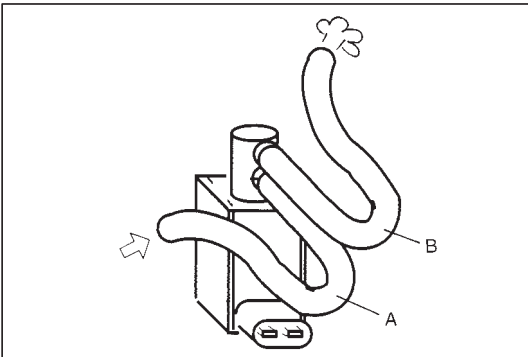

- 7) Connect 12 V-battery to solenoid purge valve terminals. In this state, blow hose "A".  
 Air should come out of hose "B".

**WARNING:**

**Do not suck the air through valve. Fuel vapor inside valve is harmful.**

If check result is as specified above, check EVAP canister purge valve harness.

If not, replace EVAP canister purge valve.

- 8) Connect vacuum hoses.
- 9) Connect EVAP canister purge valve coupler securely.

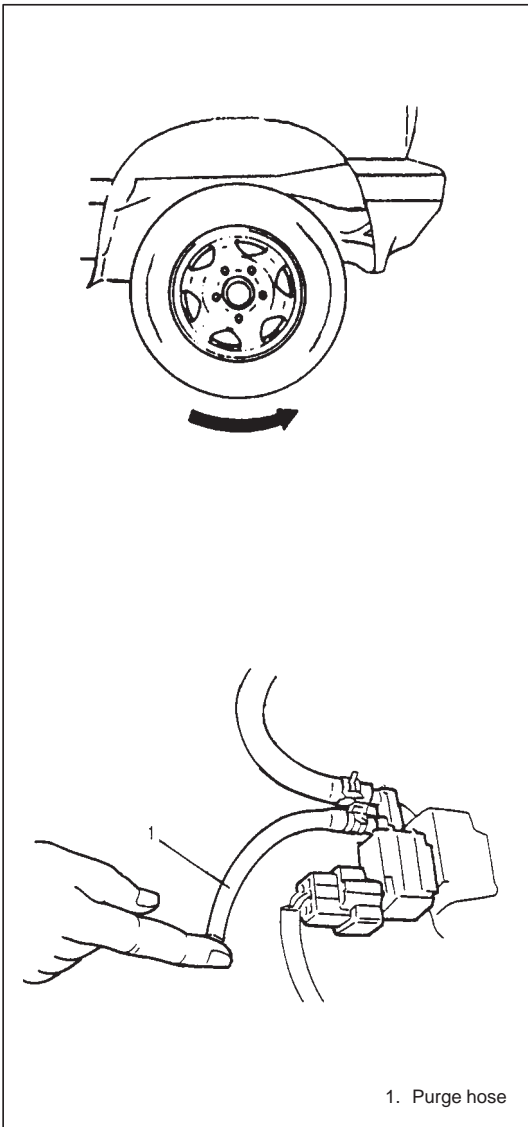

### EVAP Canister Purge System Check

- 1) Warm up engine to normal operating temperature.
- 2) Hoist vehicle so that all wheels rotate freely.
- 3) Set M/T in "Neutral" or A/T in "P" position and parking brake.
- 4) Disconnect purge hose from EVAP canister.
- 5) Place finger against the end of disconnected hose and check that vacuum is not felt there when engine is running at idle speed.
- 6) Release parking brake lever, set transfer in "2H" and M/T in "1st" or A/T in "L".

#### **WARNING:**

**Make sure that transfer is set to "2H" range position for this check. If it is set to "4H" or "4L" position, front and rear wheels turn at high speed and a very dangerous situation may occur.**

- 7) Also check that vacuum is felt when engine speed is increased to higher than about 1,500 r/min. and keep it for 3 min. or more. If check result is not described in steps 5) and 7), check EVAP canister purge valve, wire harness and vacuum passage.

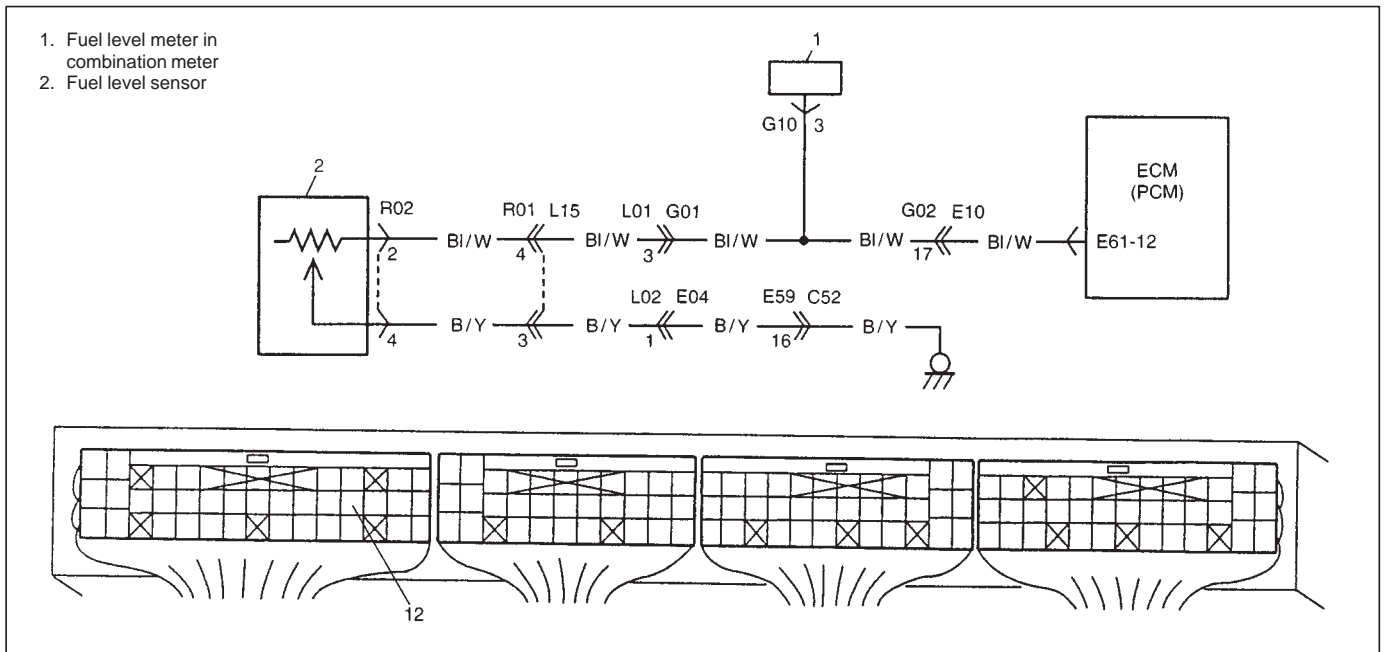
**DTC P0460 FUEL LEVEL SENSOR CIRCUIT HIGH INPUT****WIRING DIAGRAM/CIRCUIT DESCRIPTION****DTC DETECTING CONDITION AND TROUBLE AREA**

DTC DETECTING CONDITION	TROUBLE AREA
Fuel level sensor voltage higher than specified value.	Fuel level sensor and/or its circuit Fuel level meter and/or its circuit ECM (PCM)

**DTC CONFIRMATION PROCEDURE****NOTE:**

Check to make sure that the following conditions are satisfied when using this DTC CONFIRMATION PROCEDURE.

- Intake air temperature: between  $-14^{\circ}\text{C}$  and  $70^{\circ}\text{C}$  ( $6.8^{\circ}\text{F}$  and  $158^{\circ}\text{F}$ )
- Atmospheric pressure: higher than 560 mmHg (Altitude: lower than 2790 m (9150 ft))

- (1) With ignition switch OFF, connect scan tool.
- (2) Turn ON ignition switch and clear DTC by using scan tool if any.
- (3) Start engine and run it for 10 sec.
- (4) Check DTC and pending DTC by using scan tool.

**DTC TROUBLESHOOTING**

STEP	ACTION	YES	NO
1	Was "ENGINE DIAG. FLOW TABLE" performed?	Go to Step 2.	Go to "ENGINE DIAG. FLOW TABLE".
2	Fuel Level Sensor Signal Circuit check: (1) With ignition switch OFF, disconnect G10 of combination meter coupler. (2) Remove ECM (PCM) cover. (3) With ignition switch ON leaving engine OFF, check voltage between E61-12 and ground. Is voltage about 0 V?	Go to Step 3.	"BI/W" wire shorted to power circuit.
3	Fuel Level Sensor check: (1) Remove fuel level sensor referring to "ENGINE FUEL" section. (2) With ignition switch OFF, connect L15 coupler to R01 coupler. (3) With ignition switch OFF, disconnect G10 coupler of combination meter. (4) Check resistance between E61-12 and ground. float level "FULL" 2 – 4 $\Omega$ float level "EMPTY" 119 – 121 $\Omega$ Is check result satisfied?	Go to Step 4.	Faulty fuel level sensor or its harness.
4	Fuel Level Sensor Voltage check: (1) With ignition switch OFF, connect G10 coupler of combination meter. (2) With ignition switch ON leaving engine OFF, check voltage between E61-12 and ground. float level "FULL" about 0 V float level "EMPTY" about 6 V Is check result satisfied?	Intermittent trouble. If OK, substitute a known-good ECM (PCM) and recheck.	Substitute a known-good combination meter and recheck.

# DTC P0500 VEHICLE SPEED SENSOR MALFUNCTION (DTC No.24)

## WIRING DIAGRAM

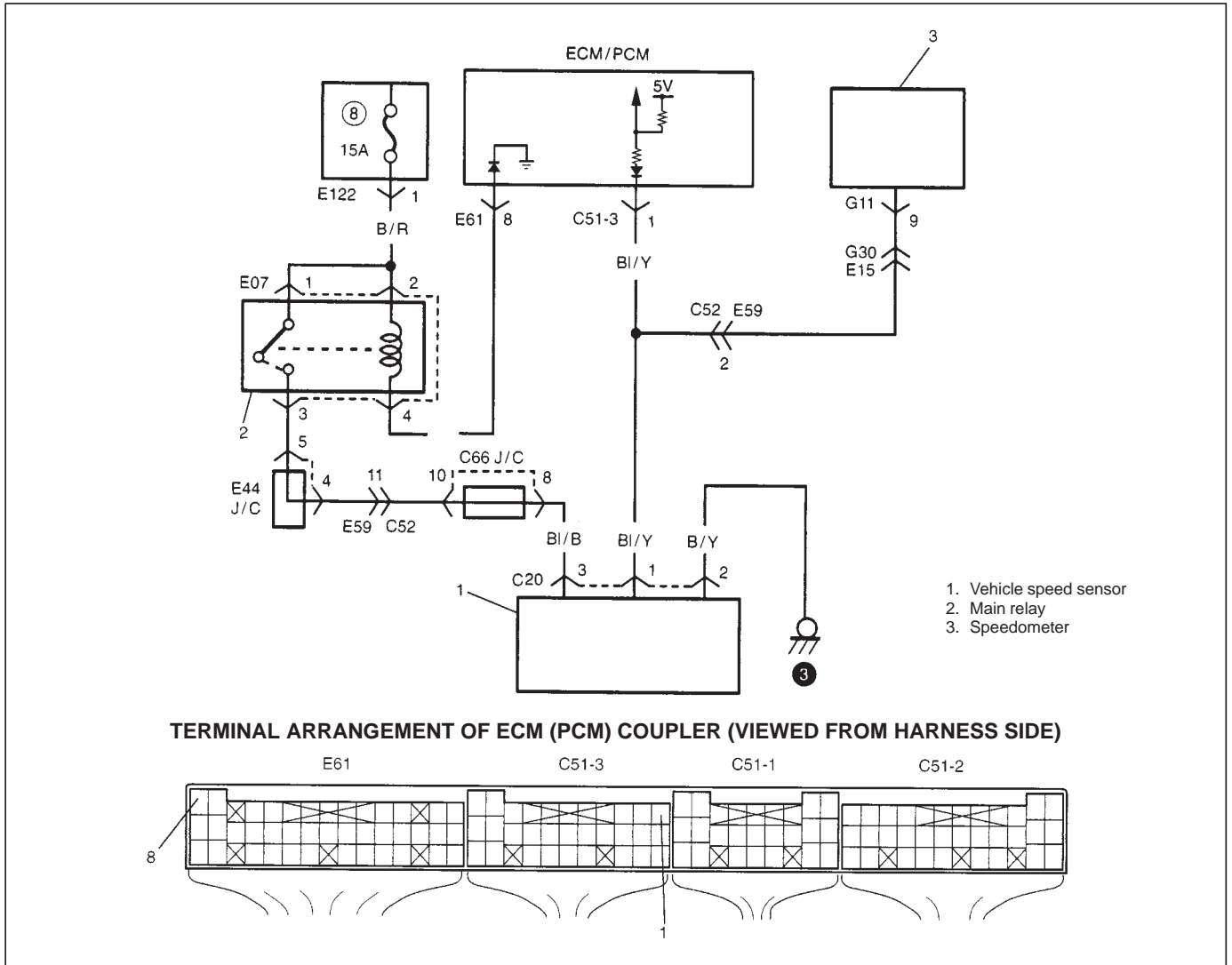

### CIRCUIT DESCRIPTION

Refer to "ENGINE AND EMISSION CONTROL" section.

### DTC DETECTING CONDITION AND TROUBLE AREA

DTC DETECTING CONDITION	TROUBLE AREA
Vehicle speed sensor signal is not inputted while fuel is cut for 4 sec.	Vehicle speed sensor Vehicle speed sensor circuit Vehicle speed sensor driven gear Speedometer ECM (PCM)

### DTC CONFIRMATION PROCEDURE

#### NOTE:

Check to make sure that following conditions are satisfied when using this DTC CONFIRMATION PROCEDURE.

**WARNING:**

- When performing a road test, select a place where there is no traffic or possibility of a traffic accident and very careful during to avoid occurrence of an accident.
- Road test, should be carried out with 2 person, a driver and tester, on a level road.

- Intake air temperature: between  $-14^{\circ}\text{C}$  and  $70^{\circ}\text{C}$  ( $6.8^{\circ}\text{F}$  and  $158^{\circ}\text{F}$ )
- Atmospheric pressure: higher than 560 mmHg (Altitude: lower than 2790 m (9150 ft))

- (1) With ignition switch OFF, connect scan tool.
- (2) Turn ON ignition switch and clear DTC by using scan tool if any.
- (3) Start engine and warm up to normal operating temperature.
- (4) Increase vehicle speed till engine speed is reached 4000 r/min. in 3rd gear (M/T) or 2nd range (A/T).
- (5) Release accelerator pedal and with engine brake applied, keep vehicle coasting and then stop vehicle.
- (6) Check DTC by using scan tool.

**DTC TROUBLESHOOTING**

STEP	ACTION	YES	NO
1	Was "ENGINE DIAG. FLOW TABLE" performed?	Go to Step 2.	Go to "ENGINE DIAG. FLOW TABLE".
2	Does speedometer indicate vehicle speed?	Faulty "BI/Y" wire, poor C51-3-1 connection or intermittent trouble. If OK, substitute a known-good ECM (PCM) and recheck.	Go to Step 3.
3	VSS Power Supply Voltage check: (1) Remove ECM (PCM) cover. (2) With ignition switch OFF, remove VSS coupler (1). (3) With ignition switch ON leaving engine OFF, check voltage between C20-3 and C20-2 terminal of VSS coupler. Is voltage 10 – 14 V?	Go to Step 4.	Faulty "B/BI", "B/Y" wire.
4	VSS Signal Harness check: (1) With ignition switch ON leaving engine OFF, check voltage between C20-1 and C20-2 terminal of VSS coupler. Is voltage 4 V or more?	Go to Step 5.	Go to Step 6.
5	VSS Visual inspection: (1) Remove VSS (2) referring to "TRANSFER" section. (2) Check VSS drive gear (4) and driven gear (3) for damage and excessive wear. Are they in good condition?	Poor VSS connection. If OK, substitute a known-good VSS and recheck.	Replace VSS.

STEP	ACTION	YES	NO
6	<p>Speedometer Circuit check:</p> <p>(1) With ignition switch OFF, disconnect G11 coupler from combination meter.</p> <p>(2) With ignition switch ON leaving engine OFF, check voltage between C20-1 and C20-2 terminal of VSS coupler.</p> <p>Is voltage 4 V or more?</p>	Substitute a known-good combination meter and recheck.	Faulty "BI/Y" wire. If OK, substitute a known-good ECM (PCM) and recheck.

Fig. for STEP 3

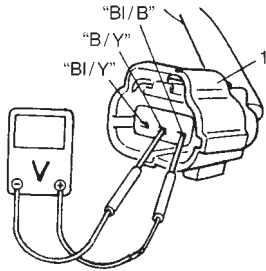

Fig. for STEP 4, 6

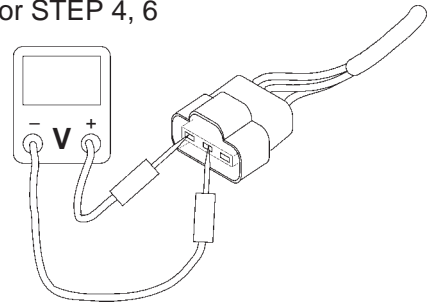
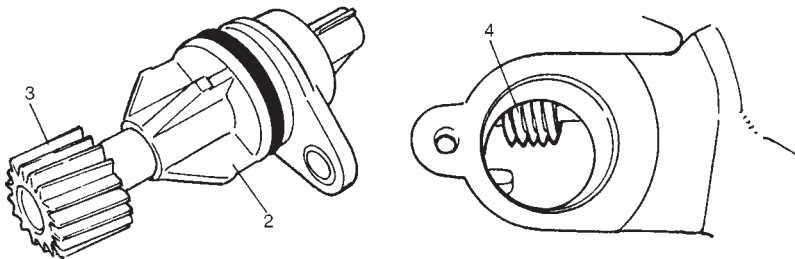
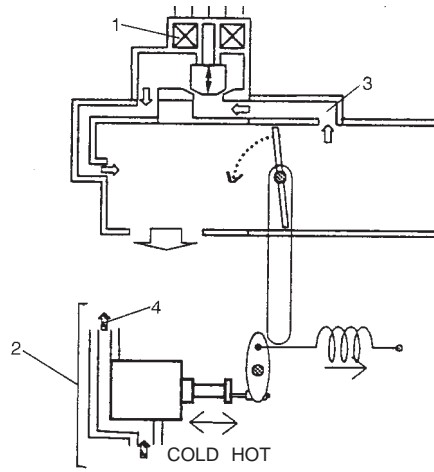

Fig. for STEP 5



### DTC P0505 IDLE AIR CONTROL SYSTEM MALFUNCTION SYSTEM/WIRING DIAGRAM



- 1. IAC valve
- 2. Fast idle control system
- 3. Bypass air
- 4. Engine coolant
- 5. Main relay

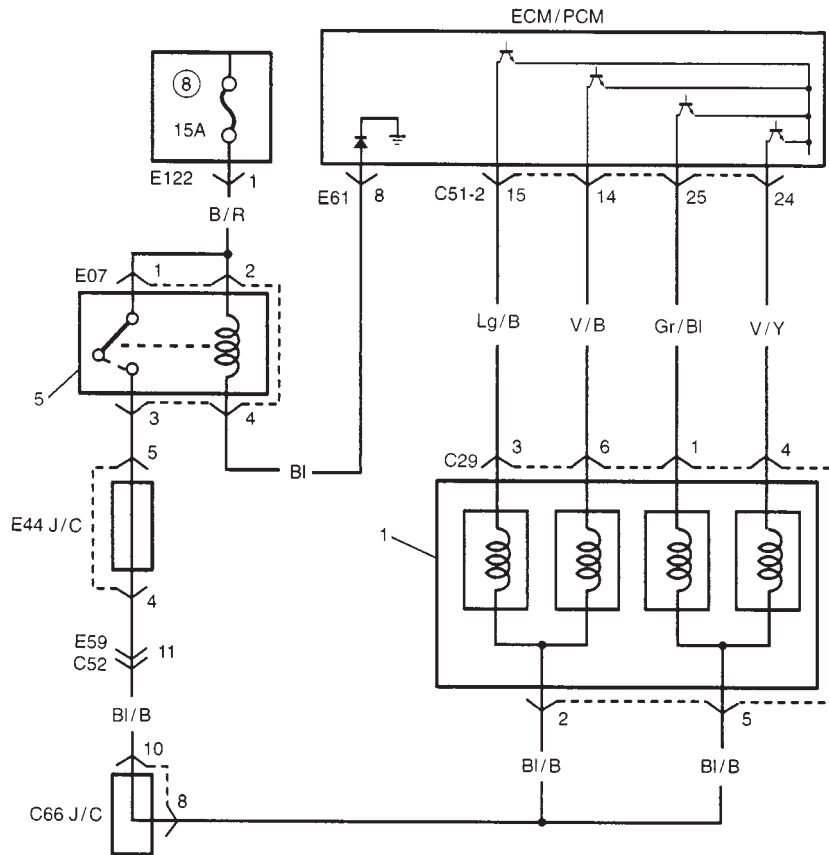

**TERMINAL ARRANGEMENT OF ECM (PCM) COUPLER (VIEWED FROM HARNESS SIDE)**

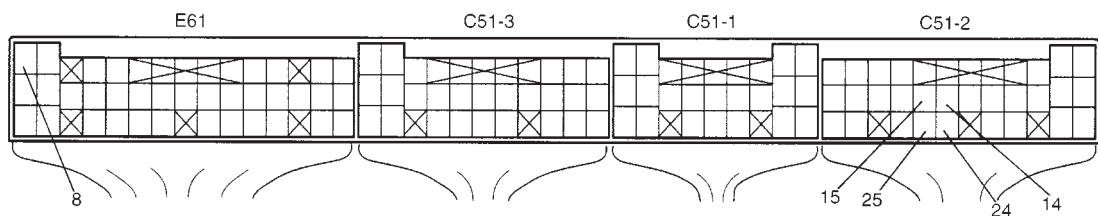

**SYSTEM/CIRCUIT DESCRIPTION**

Refer to "ENGINE AND EMISSION CONTROL" section.

**DTC DETECTING CONDITION AND TROUBLE AREA**

DTC DETECTING CONDITION	TROUBLE AREA
Idle engine speed is lower than desired engine speed 100 r/min. though IAC valve opening is about 100 %. Idle engine speed is higher than desired engine speed 200 r/min. though IAC valve opening is about 0 %. IAC valve monitor voltage is high.	IAC valve or its circuit Air intake system VSS Engine mechanical External load ECM (PCM)

**DTC CONFIRMATION PROCEDURE****NOTE:**

**Check to make sure that following conditions are satisfied when using this DTC CONFIRMATION PROCEDURE.**

- **Intake air temperature: between  $-14^{\circ}\text{C}$  and  $70^{\circ}\text{C}$  ( $6.8^{\circ}\text{F}$  and  $158^{\circ}\text{F}$ )**
- **Atmospheric pressure: higher than 560 mmHg (Altitude: lower than 2790 m (9150 ft))**

- (1) With ignition switch OFF, connect scan tool.
- (2) Turn ON ignition switch and clear DTC by using scan tool if any.
- (3) Start engine and warm up to normal operating temperature.
- (4) Run engine at idle speed for 30 sec.
- (5) Check DTC and pending DTC by using scan tool.

**DTC TROUBLESHOOTING**

STEP	ACTION	YES	NO
1	Was "ENGINE DIAG. FLOW TABLE" performed?	Go to Step 2.	Go to "ENGINE DIAG. FLOW TABLE".
2	Idle Speed check: (1) Check idle speed and idle air control duty referring to "ENGINE AND EMISSION CONTROL" section. Are they in good condition?	Intermittent trouble. If OK, substitute a known-good ECM (PCM) and recheck.	Go to Step 3.
3	IAC Valve inspection: (1) Inspect IAC valve referring to "ENGINE AND EMISSION CONTROL" section. Is it in good condition?	Go to Step 6.	Go to Step 4.
4	IAC Valve Circuit check: (1) With ignition switch OFF, disconnect ECM (PCM) couplers. (2) Check resistance between C51-2-14 and C51-2-15, C51-2-24 and C51-2-25. Is each resistance 40 – 48 $\Omega$ ?	Go to Step 5.	Faulty "Lg/B", "V/B", "Gr/BI" or "V/Y" wire. If OK, faulty IAC valve.
5	IAC Valve Power Supply Voltage check: (1) Connect ECM (PCM) couplers. (2) With ignition switch OFF, disconnect C29 coupler (1) of IAC valve. (3) With ignition switch ON, check voltage between C29-2 (b) and ground, C29-5 (e) and ground. Is each voltage 10 – 14 V?	IAC valve or ECM (PCM) malfunction.	Faulty "BI/B" wire.

STEP	ACTION	YES	NO
6	Air Intake System check: (1) Check air intake system for clog and air inhibit. (2) Check fast idle up system referring to "ENGINE AND EMISSION CONTROL" section. Are they in good condition?	Go to Step 7.	Repair or replace.
7	VSS check: (1) Perform DTC confirm procedure of VSS referring to DTC P0500. Is DTC P0500 detected?	Go to DTC P0500 flow table.	Go to Step 8.
8	Engine Mechanical check: (1) Check engine mechanical referring to "ENGINE MECHANICAL" section. Is engine mechanical in good condition?	Go to Step 9.	Repair or replace.
9	External Load check: (1) Check external loads (power steering pump, air conditioner compressor, alternator, transmission, etc.). Are they in good condition?	Substitute a known-good ECM (PCM) and recheck.	Repair or replace.

Fig. for STEP 5

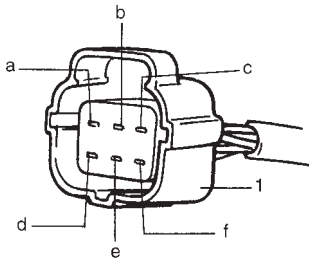

**DTC P0601 INTERNAL CONTROL MODULE MEMORY CHECK SUM ERROR****SYSTEM DESCRIPTION**

Internal control module is installed in ECM (PCM).

**DTC DETECTING CONDITION AND TROUBLE AREA**

DTC DETECTING CONDITION	TROUBLE AREA
Check sum is not equal to specified value.	ECM (PCM)

**DTC CONFIRMATION PROCEDURE****NOTE:**

**Check to make sure that following conditions are satisfied when using this DTC CONFIRMATION PROCEDURE.**

- (1) With ignition switch OFF, connect scan tool.
- (2) Turn ON ignition switch and clear DTC by using scan tool if any.
- (3) Start engine and run it for 10 sec.
- (4) Check DTC by using scan tool.

**DTC TROUBLESHOOTING**

STEP	ACTION	YES	NO
1	Was "ENGINE DIAG. FLOW TABLE" performed?	Substitute a known-good ECM (PCM) and recheck.	Go to "ENGINE DIAG. FLOW TABLE".

## DTC P1408 MANIFOLD ABSOLUTE PRESSURE SENSOR CIRCUIT MALFUNCTION WIRING DIAGRAM

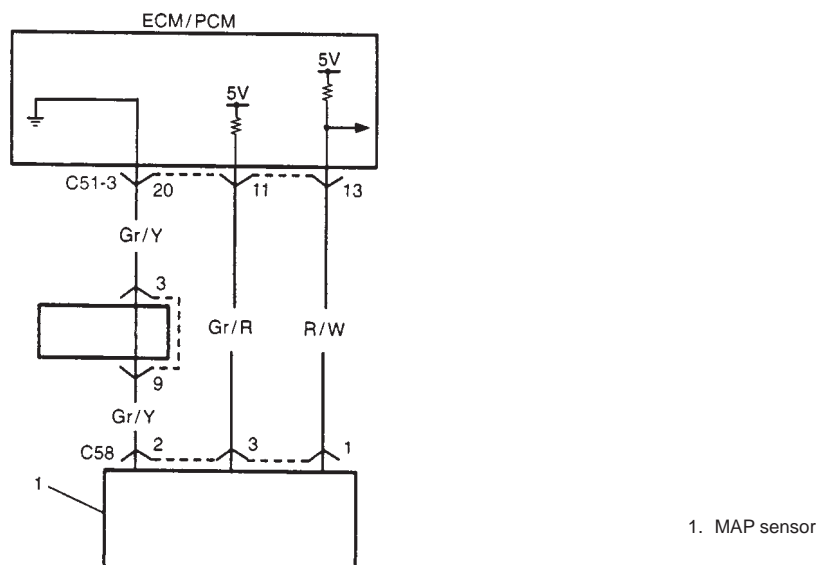

### TERMINAL ARRANGEMENT OF ECM (PCM) COUPLER (VIEWED FROM HARNESS SIDE)

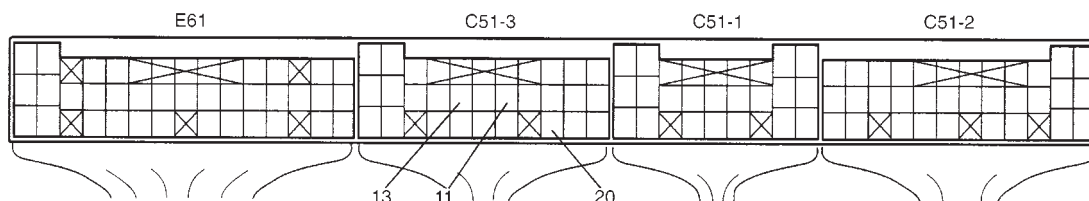

### CIRCUIT DESCRIPTION

Refer to "ENGINE AND EMISSION CONTROL" section.

### DTC DETECTING CONDITION AND TROUBLE AREA

DTC DETECTING CONDITION	TROUBLE AREA
MAP sensor signal voltage continues more than 2.7 V for 5 sec. under low load condition. MAP sensor signal voltage continues less than 1.1 V for 5 sec. under high load condition.	MAP sensor and its circuit ECM (PCM)

### DTC CONFIRMATION PROCEDURE

#### NOTE:

Check to make sure that following conditions are satisfied when using this DTC CONFIRMATION PROCEDURE.

#### WARNING:

- When performing a road test, select a place where there is no traffic or possibility of a traffic accident and very careful during to avoid occurrence of an accident.
- Road test, should be carried out with 2 person, a driver and tester, on a level road.

- Intake air temperature: between 5 °C and 70 °C (6.8 °F and 158 °F)
- Atmospheric pressure: higher than 560 mmHg (Altitude: lower than 2790 m (9150 ft))

- (1) With ignition switch OFF, connect scan tool.
- (2) Turn ON ignition switch and clear DTC by using scan tool if any.
- (3) Start engine and warm up to normal operating temperature.
- (4) Increase vehicle speed to 56 km/h (35 mph) for 30 sec.
- (5) Stop vehicle and run engine at idle speed for 10 sec.
- (6) Check DTC and pending DTC by using scan tool.

## DTC TROUBLESHOOTING

STEP	ACTION	YES	NO
1	Was "ENGINE DIAG. FLOW TABLE" performed?	Go to Step 2.	Go to "ENGINE DIAG. FLOW TABLE".
2	MAP Sensor Signal check: (1) Remove ECM (PCM) cover. (2) Check voltage between C51-3-13 and C51-3-20 as following conditions. with ignition switch on leaving engine OFF: 3.3 – 4.3 V idling: less than 3.3 V Is check result as specified?	Intermittent trouble. If OK, substitute a known-good ECM (PCM) and recheck.	Go to Step 3.
3	MAP Sensor Power Supply Voltage check: (1) With ignition switch OFF, disconnect C58 coupler from MAP sensor. (2) Check voltage between C58-3 and C58-2 terminal. Is voltage 4.5 – 5.5 V?	Faulty "R/W" wire. If OK, substitute a known-good MAP sensor and recheck.	Faulty "Gr/R", "Gr/Y" wire. If OK, substitute a known-good ECM (PCM) and recheck.

Fig. for STEP 3

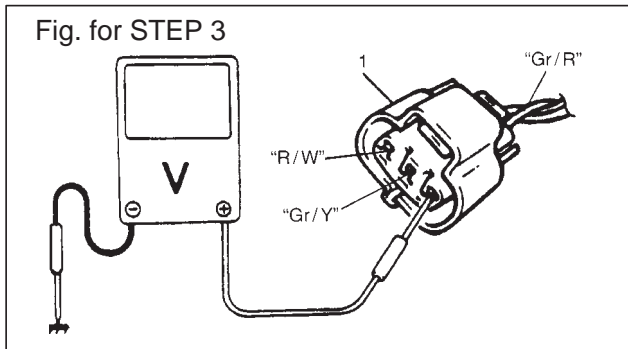

## DTC P1450 BAROMETRIC PRESSURE SENSOR CIRCUIT MALFUNCTION DTC P1451 BAROMETRIC PRESSURE SENSOR PERFORMANCE PROBLEM

### SYSTEM DESCRIPTION

Barometric pressure sensor is installed in ECM (PCM).

### DTC DETECTING CONDITION AND TROUBLE AREA

DTC DETECTING CONDITION	TROUBLE AREA
<p><b>P1450</b> Barometric pressure sensor voltage is less than 0.1 V or more than 5.1 V.</p> <p><b>P1451</b> Barometric pressure value does not agree with calculated barometric pressure.</p>	<p>Barometric pressure sensor in ECM (PCM). MAP sensor</p>

### DTC CONFIRMATION PROCEDURE

#### NOTE:

Check to make sure that following conditions are satisfied when using this DTC CONFIRMATION PROCEDURE.

- Intake air temperature: between 5 °C and 70 °C (6.8 °F and 158 °F)
- Atmospheric pressure: higher than 560 mmHg (Altitude: lower than 2790 m (9150 ft))

- (1) With ignition switch OFF, connect scan tool.
- (2) Turn ON ignition switch and clear DTC by using scan tool if any.
- (3) Start engine and warm up to normal operating temperature.
- (4) Run engine at idle speed for 30 sec.
- (5) Check DTC and pending DTC by using scan tool.

## DTC TROUBLESHOOTING

STEP	ACTION	YES	NO								
1	Was "ENGINE DIAG. FLOW TABLE" performed?	Go to Step 2.	Go to "ENGINE DIAG. FLOW TABLE".								
2	1) Connect scan tool to DLC with ignition switch OFF. 2) Turn ignition switch ON and select "DATA LIST" mode on scan tool. 3) Check manifold absolute pressure. Is it barometric pressure (approx. 100 kPa, 760 mmHg) at seal level?	Substitute a known-good ECM (PCM) and recheck.	Go to Step 2.								
3	<p>Check MAP Sensor</p> <p>1) Remove MAP sensor from intake manifold and connect vacuum pump gauge to MAP sensor.</p> <p>2) Connect scan tool to DLC and turn ignition switch ON.</p> <p>3) Check intake manifold absolute pressure displayed on scan tool under following conditions.</p> <table border="1" data-bbox="166 803 829 1127"> <thead> <tr> <th>Applying Vacuum</th> <th>Displayed Value on Scan Tool</th> </tr> </thead> <tbody> <tr> <td>0</td> <td>Barometric pressure (Approx. 100 kPa, 760 mmHg)</td> </tr> <tr> <td>27 kPa 200 mmHg</td> <td>Barometric pressure -27 kPa (Approx. 73 kPa, 560 mmHg)</td> </tr> <tr> <td>67 kPa 500 mmHg</td> <td>Barometric pressure -67 kPa (Approx. 33 kPa, 260 mmHg)</td> </tr> </tbody> </table> <p>Is check result satisfactory?</p>	Applying Vacuum	Displayed Value on Scan Tool	0	Barometric pressure (Approx. 100 kPa, 760 mmHg)	27 kPa 200 mmHg	Barometric pressure -27 kPa (Approx. 73 kPa, 560 mmHg)	67 kPa 500 mmHg	Barometric pressure -67 kPa (Approx. 33 kPa, 260 mmHg)	Check air intake system for air being drawn in and engine compression. If OK, then substitute a known-good ECM and recheck.	Replace MAP sensor.
Applying Vacuum	Displayed Value on Scan Tool										
0	Barometric pressure (Approx. 100 kPa, 760 mmHg)										
27 kPa 200 mmHg	Barometric pressure -27 kPa (Approx. 73 kPa, 560 mmHg)										
67 kPa 500 mmHg	Barometric pressure -67 kPa (Approx. 33 kPa, 260 mmHg)										

Fig. for STEP 3

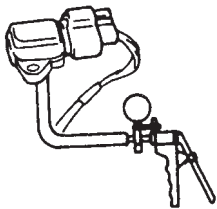

## DTC P1500 ENGINE START SIGNAL CIRCUIT MALFUNCTION WIRING DIAGRAM

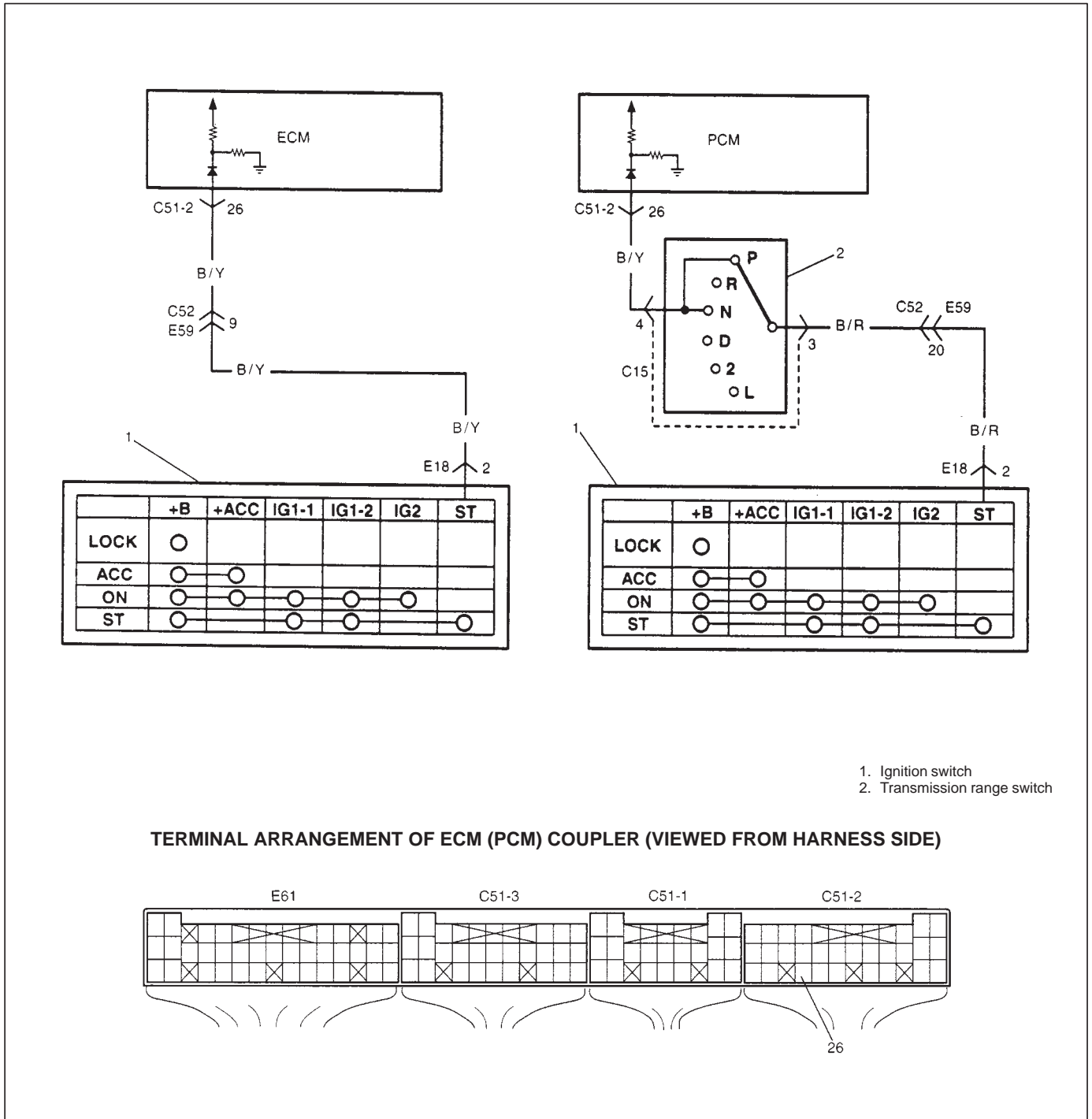

### CIRCUIT DESCRIPTION

Engine start signal is sent from engine starter circuit while engine cranking.

### DTC DETECTING CONDITION AND TROUBLE AREA

DTC DETECTING CONDITION	TROUBLE AREA
Though engine starts, engine start signal is not inputted. Engine start signal is inputted for 20 sec. or more.	Engine start signal circuit ECM (PCM)

**DTC CONFIRMATION PROCEDURE****NOTE:**

Check to make sure that following conditions are satisfied when using this DTC CONFIRMATION PROCEDURE.

- Intake air temperature: between  $-14^{\circ}\text{C}$  and  $70^{\circ}\text{C}$  ( $6.8^{\circ}\text{F}$  and  $158^{\circ}\text{F}$ )
- Atmospheric pressure: higher than 560 mmHg (Altitude: lower than 2790 m (9150 ft))

- (1) With ignition switch OFF, connect scan tool.
- (2) Turn ON ignition switch and clear DTC by using scan tool if any.
- (3) Start engine and run it for 5 min.
- (4) Check DTC and pending DTC by using scan tool.

**DTC TROUBLESHOOTING**

STEP	ACTION	YES	NO
1	Was "ENGINE DIAG. FLOW TABLE" performed?	Go to Step 2.	Go to "ENGINE DIAG. FLOW TABLE".
2	Engine Start Signal check: (1) Remove ECM (PCM) cover. (2) While engine running, check voltage between C51-2-26 and ground. Is voltage 0 – 1 V?	Go to Step 3.	"B/Y" wire shorted to power circuit.
3	Engine Start Signal check: (1) While engine cranking, check voltage between C51-2-26 and ground. Is voltage 6 – 14 V?	Intermittent trouble. If OK, substitute a known-good ECM (PCM) and recheck.	"B/Y" wire open. If OK, substitute a known-good ECM (PCM) and recheck.

## DTC P1510 ECM BACK-UP POWER SUPPLY MALFUNCTION WIRING DIAGRAM

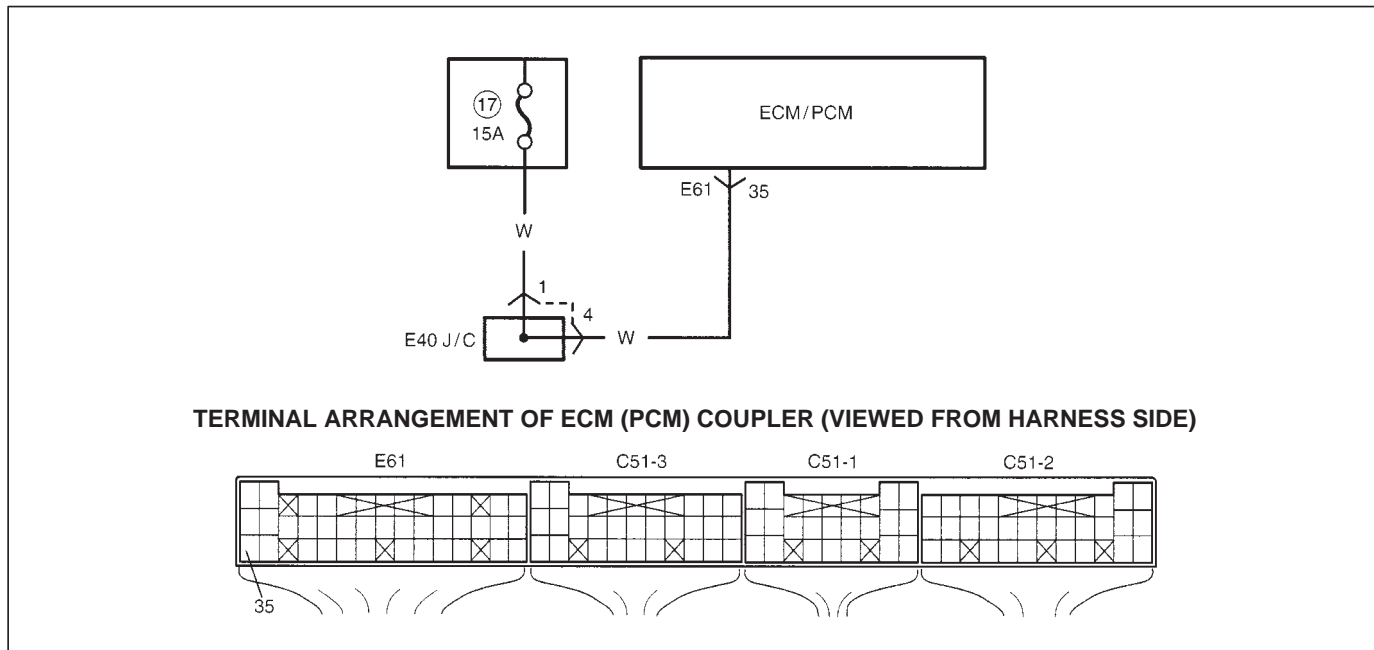

### CIRCUIT DESCRIPTION

Battery voltage is translated to 5 V in ECM (PCM) back-up circuit. The voltage is supplied to keep DTC memory, values that ECM (PCM) has learned to control engine, etc. in ECM (PCM) even when ignition switch is turned OFF.

### DTC DETECTING CONDITION AND TROUBLE AREA

DTC DETECTING CONDITION	TROUBLE AREA
Back-up circuit voltage is out of specification.	Battery voltage supply circuit ECM (PCM)

### DTC CONFIRMATION PROCEDURE

#### NOTE:

Check to make sure that following conditions are satisfied when using this DTC CONFIRMATION PROCEDURE.

- Intake air temperature: between  $-14^{\circ}\text{C}$  and  $70^{\circ}\text{C}$  ( $6.8^{\circ}\text{F}$  and  $158^{\circ}\text{F}$ )
- Atmospheric pressure: higher than 560 mmHg (Altitude: lower than 2790 m (9150 ft))

- (1) With ignition switch OFF, connect scan tool.
- (2) Turn ON ignition switch and clear DTC by using scan tool if any.
- (3) Start engine and run it for 10 sec.
- (4) Check DTC by using scan tool.

### DTC TROUBLESHOOTING

STEP	ACTION	YES	NO
1	Was "ENGINE DIAG. FLOW TABLE" performed?	Go to Step 2.	Go to "ENGINE DIAG. FLOW TABLE".
2	Battery Voltage Supply Circuit check: (1) Remove ECM (PCM) cover. (2) While engine running, check voltage between E61-35 and ground. Is voltage 10 – 14 V?	Intermittent trouble. If OK, substitute a known-good ECM (PCM) and recheck.	Fuse 17 is blown or faulty "W" wire.

## TABLE B-1 FUEL PUMP CIRCUIT CHECK WIRING DIAGRAM

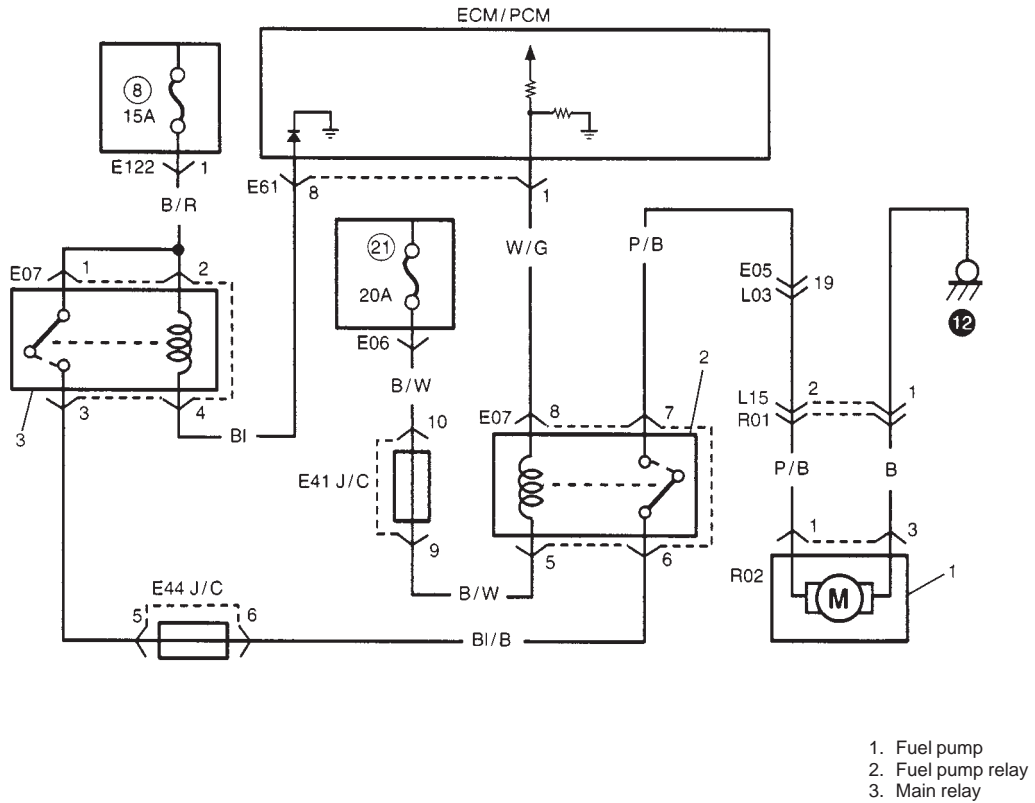

### TERMINAL ARRANGEMENT OF ECM (PCM) COUPLER VIEWED FROM HARNESS SIDE

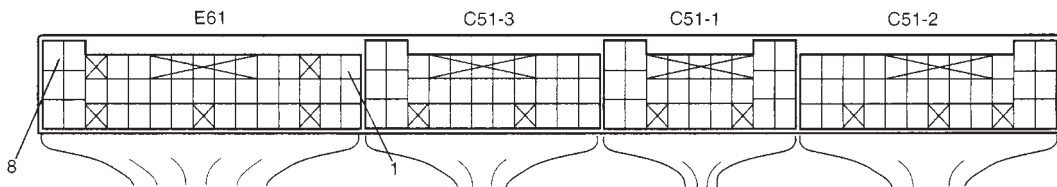

### CIRCUIT DESCRIPTION

Fuel pump relay is turned ON

- ° for 3 sec. after ignition switch is turned ON
- ° while start engine signal is inputted.
- ° while engine is running.

## TROUBLESHOOTING

STEP	ACTION	YES	NO
1	Fuel Pump Operation check: (1) Remove fuel filler cap. (2) Turn On ignition switch. Is fuel pump operation sound heard for 3 sec. after ignition switch ON?	Fuel pump circuit is in good condition.	Go to Step 2.
2	Fuel Pump Circuit check: (1) With ignition switch OFF, remove fuel pump relay from relay box. (2) Using service wire (1), connect E07-6 and E07-7. Is fuel pump operation sound heard with ignition switch ON?	Go to Step 3.	"BI/B", "P/B" wire open. "B" wire open, poor 12 connection. Fuel pump malfunction.
3	Fuel Pump Relay check: (1) Check fuel pump relay referring to "ENGINE AND EMISSION CONTROL" section. Is it in good condition?	"B/W", "W/G" wire open.	Faulty fuel pump relay.

Fig. for STEP 2

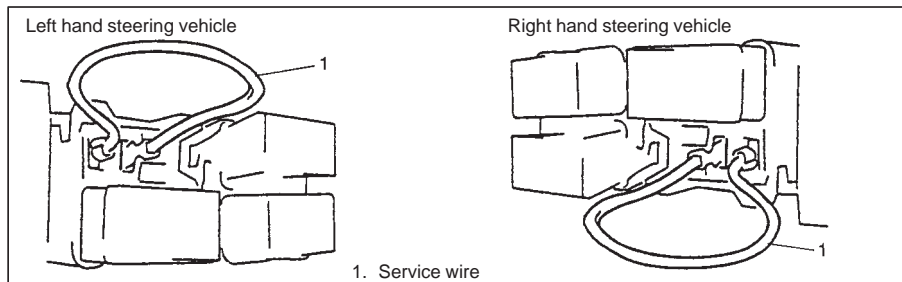

**TABLE B-2 FUEL INJECTOR CIRCUIT CHECK  
WIRING DIAGRAM**

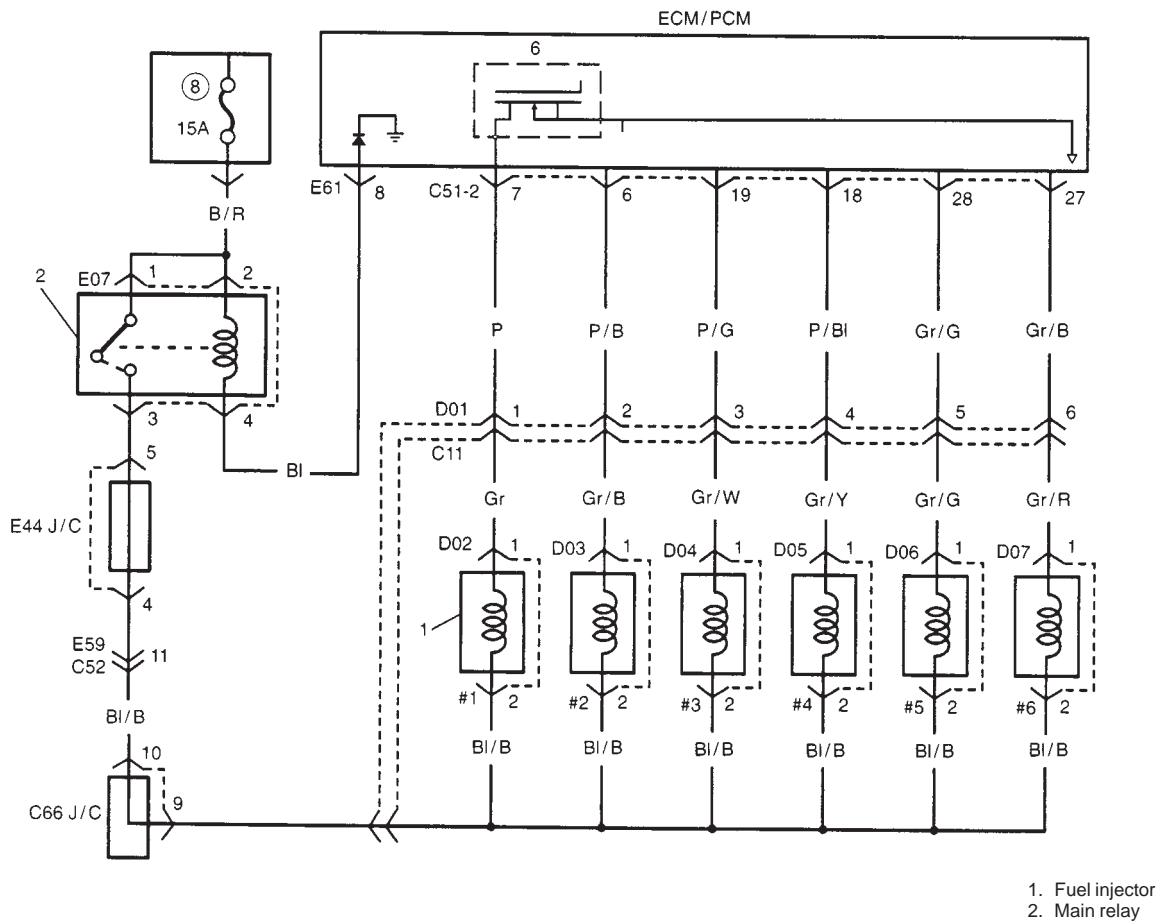

**TERMINAL ARRANGEMENT OF ECM (PCM) COUPLER VIEWED FROM HARNESS SIDE**

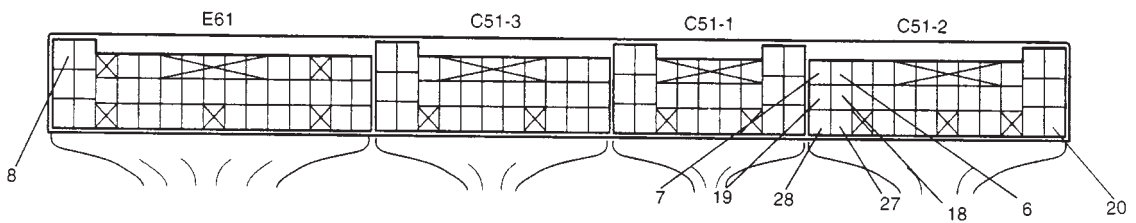

## TROUBLESHOOTING

STEP	ACTION	YES	NO							
1	Fuel Injector Operation check: (1) Using sound scope, check each injector for operating sound at engine cranking. Do all 6 injectors make operating sound?	Go to Step 2.	Go to Step 3.							
2	Fuel Injector Circuit check: (1) Remove ECM (PCM) cover. (2) With ignition switch OFF, remove ECM (PCM) couplers. (3) Check resistance between following terminals. <table style="margin-left: 40px; border-collapse: collapse;"> <tr> <td style="padding-right: 10px;">C51-2-6 – C51-2-20</td> <td rowspan="6" style="border-left: 1px solid black; border-right: 1px solid black; padding: 0 10px;">10 – 14 Ω at 20°C</td> </tr> <tr> <td>C51-2-7 – C51-2-20</td> </tr> <tr> <td>C51-2-18 – C51-2-20</td> </tr> <tr> <td>C51-2-19 – C51-2-20</td> </tr> <tr> <td>C51-2-27 – C51-2-20</td> </tr> <tr> <td>C51-2-28 – C51-2-20</td> </tr> </table> Is check result as specified?	C51-2-6 – C51-2-20	10 – 14 Ω at 20°C	C51-2-7 – C51-2-20	C51-2-18 – C51-2-20	C51-2-19 – C51-2-20	C51-2-27 – C51-2-20	C51-2-28 – C51-2-20	Fuel injector circuit is in good condition.	Go to Step 3.
C51-2-6 – C51-2-20	10 – 14 Ω at 20°C									
C51-2-7 – C51-2-20										
C51-2-18 – C51-2-20										
C51-2-19 – C51-2-20										
C51-2-27 – C51-2-20										
C51-2-28 – C51-2-20										
3	Does not of 6 injectors make operating sound at Step 1?	Go to Step 4.	Faulty wire harness.							
4	Fuel Injector Power Circuit check: (1) Connect ECM (PCM) couplers. (2) With ignition switch ON, check voltage between following terminals. <table style="margin-left: 40px; border-collapse: collapse;"> <tr> <td style="padding-right: 10px;">C51-2-6 – ground</td> <td rowspan="6" style="border-left: 1px solid black; border-right: 1px solid black; padding: 0 10px;">10 – 14 V</td> </tr> <tr> <td>C51-2-7 – ground</td> </tr> <tr> <td>C51-2-18 – ground</td> </tr> <tr> <td>C51-2-19 – ground</td> </tr> <tr> <td>C51-2-27 – ground</td> </tr> <tr> <td>C51-2-28 – ground</td> </tr> </table> Is check result as specified?	C51-2-6 – ground	10 – 14 V	C51-2-7 – ground	C51-2-18 – ground	C51-2-19 – ground	C51-2-27 – ground	C51-2-28 – ground	Substitute a known-good ECM (PCM) and recheck.	Faulty "BI/B" wire.
C51-2-6 – ground	10 – 14 V									
C51-2-7 – ground										
C51-2-18 – ground										
C51-2-19 – ground										
C51-2-27 – ground										
C51-2-28 – ground										

**TABLE B-3 FUEL PRESSURE CHECK  
SYSTEM DIAGRAM**

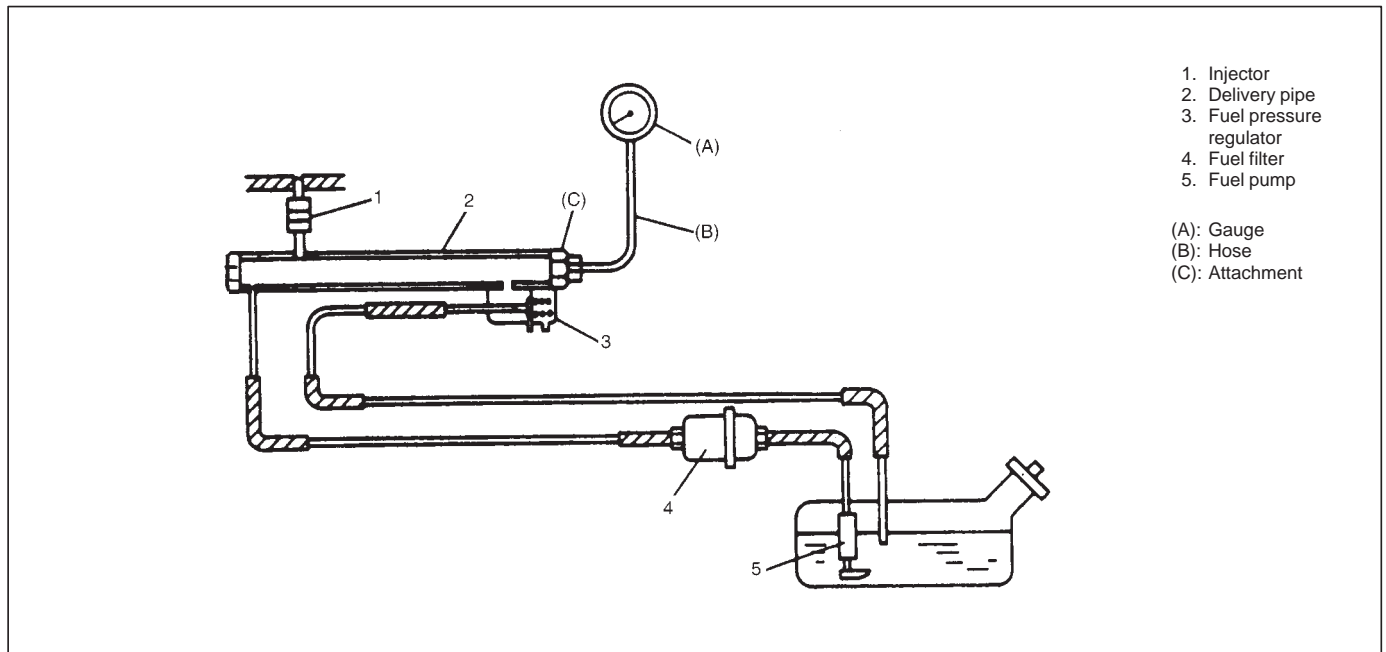

### SYSTEM DESCRIPTION

Fuel pressure regulator keeps the fuel pressure applied to injector 290 kPa higher than that in intake manifold at all times.

### INSPECTION

#### NOTE:

**Before using following table, check to make sure that battery voltage is higher than 11 V. If battery voltage is low, pressure becomes lower than specification even if fuel pump and line are in good condition.**

STEP	ACTION	YES	NO
1	Fuel Pump Operation check: (1) Remove fuel filler cap. (2) Turn ON ignition switch. Is fuel pump operation sound heard for 3 sec. after ignition switch ON?	Go to Step 2.	Go to B-1 flow table.
2	Fuel Pressure check (engine stops): (1) Install fuel filler cap and fuel pressure gauge referring to "ENGINE AND EMISSION CONTROL" section. (2) Operate fuel pump. Is fuel pressure 270 – 310 kPa?	Go to Step 3.	Go to Step 6.
3	Is 200 kPa or higher fuel pressure retained for 1 minute after fuel pump is stopped at Step 2?	Go to Step 4.	Go to Step 5.
4	Fuel Pressure check (idling): (1) Start engine and warm it up to normal operating temperature. (2) Keep it running at specified idle speed. Is fuel pressure 210 – 260 kPa?	Normal fuel pressure.	Faulty vacuum passage for fuel pressure regulator or fuel pressure regulator.

STEP	ACTION	YES	NO
5	Is there fuel leakage from fuel feed line hose, pipe or joint?	Fuel leakage from fuel feed line hose, pipe or joint.	Fuel leakage from injector, fuel pressure regulator or fuel pump.
6	Was fuel pressure higher than specification in Step 2?	Go to Step 7.	Go to Step 8.
7	Fuel Return Line check: (1) Disconnect fuel return hose from fuel pipe and connect new hose to it. (2) Put the other end of new return hose into approved gasoline container. (3) Operate fuel pump. Is fuel pressure 270 – 310 kPa?	Restricted fuel return hose or pipe.	Faulty fuel pressure regulator.
8	Fuel Pressure Regulator check: (1) With fuel pump operated and fuel return hose blocked by pinching. Is fuel pressure applied then?	Faulty fuel pressure regulator.	Clogged fuel filter, restricted fuel feed hose or pipe, faulty fuel pump or fuel leakage from hose connection in fuel tank.

## TABLE B-4 A/C SIGNAL CIRCUIT CHECK (IF EQUIPPED) CIRCUIT DIAGRAM

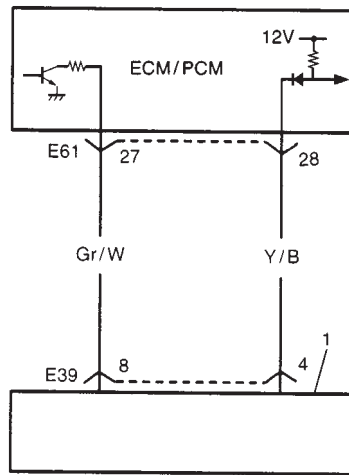

1. A/C control module

### TERMINAL ARRANGEMENT OF ECM (PCM) COUPLER VIEWED FROM HARNESS SIDE

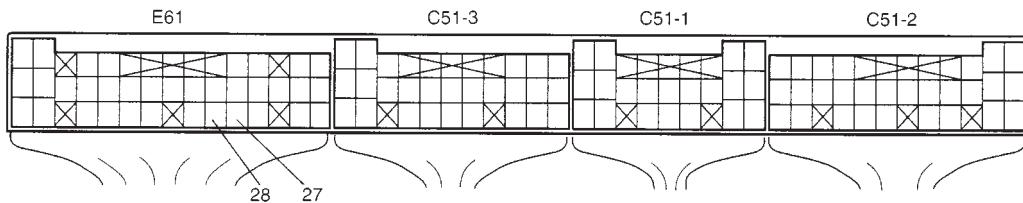

### CIRCUIT DESCRIPTION

ECM (PCM) outputs A/C ON signal (one of the signals for A/C control module to control the A/C) to A/C control module when A/C switch signal inputted to ECM (PCM) and engine conditions are specified.

### INSPECTION

STEP	ACTION	YES	NO
1	<p>A/C Switch Signal Circuit check:</p> <p>(1) Remove ECM (PCM) cover.</p> <p>(2) Check voltage between E61-28 and ground under following conditions.</p> <p>Ignition switch ON and A/C switch and/or heater blower switch OFF 10 – 14 V</p> <p>Ignition switch ON and both A/C switch and heater blower switch ON 0 – 1.5 V</p> <p>Are check results as specified?</p>	Go to Step 2.	Faulty "Y/B" wire, evaporative temperature is bellow 1°C or faulty A/C system.

STEP	ACTION	YES	NO
2	A/C ON Signal check: (1) Check voltage between E61-27 and ground under following conditions. Engine running and A/C switch and/or heater blower switch OFF 0 – 1.5 V Ignition switch ON and both A/C switch and heater blower switch ON 10 – 14 V Are check results as specified?	A/C signal circuit is in good condition.	Faulty "Gr/W", poor performance of ECT sensor, TP sensor, inputted engine start signal or faulty A/C control module. If none of the above exists, substitute a known-good ECM (PCM) and recheck.

## TABLE B-5 A/C CONDENSER FAN MOTOR RELAY CONTROL SYSTEM CHECK (IF EQUIPPED)

### CIRCUIT DIAGRAM

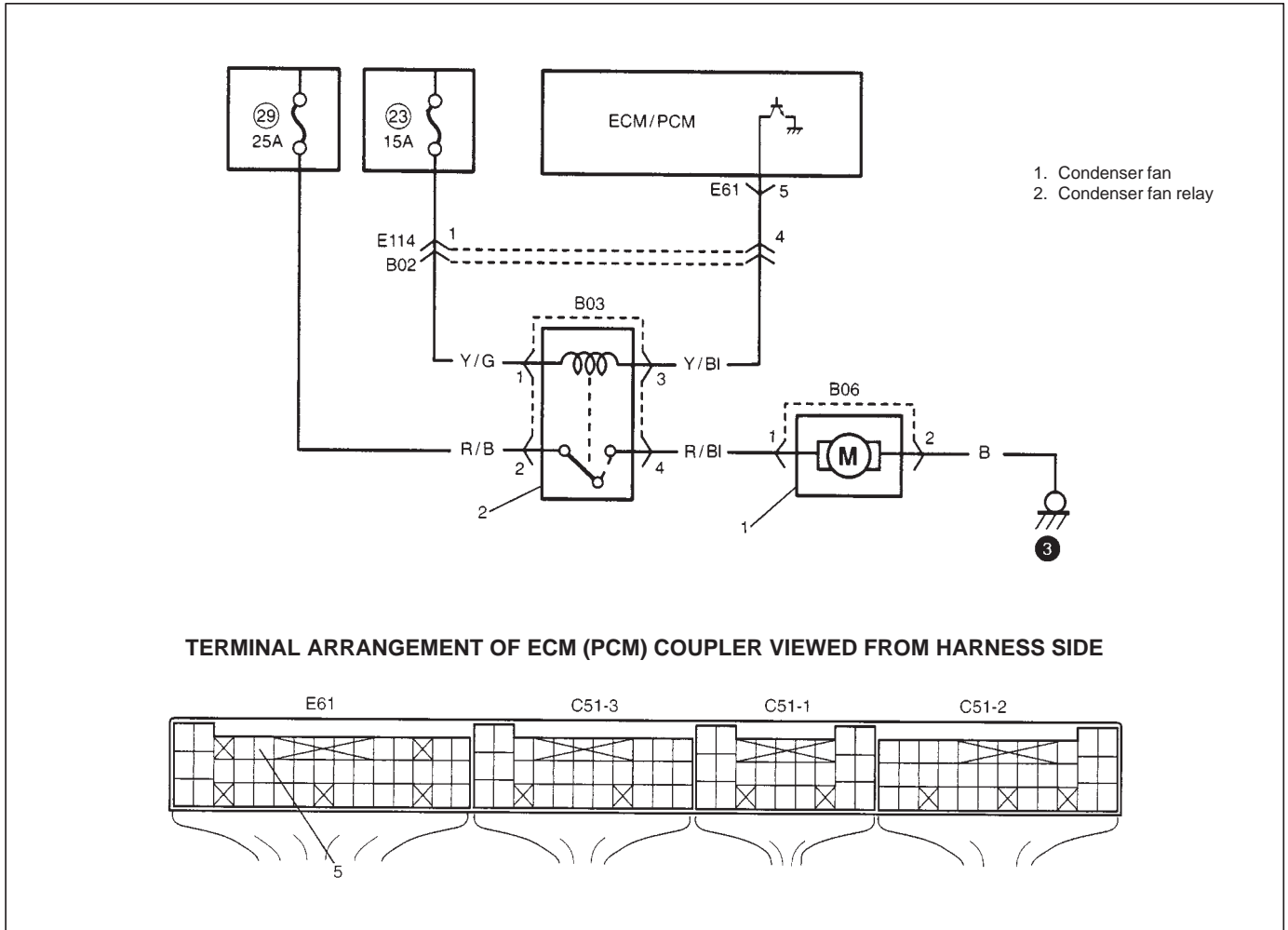

### CIRCUIT DESCRIPTION

A/C condenser fan is turned ON by ECM (PCM) when engine coolant temperature is higher than specified value regardless A/C ON or OFF.

### INSPECTION

STEP	ACTION	YES	NO
1	<p>A/C Condenser Fan Operation check:</p> <p>(1) Check A/C condenser fan for operation.</p> <p>A/C condenser fan should be operated under following condition A or B only.</p> <p>A: When engine is running and A/C is operating.</p> <p>B: When engine coolant temperature is more than 113°C with ignition switch ON.</p> <p>Is check result as specified?</p>	This system is in good condition.	Go to Step 2.

STEP	ACTION	YES	NO
2	A/C Condenser Fan Control Signal check: (1) Remove ECM (PCM) cover. (2) Check voltage between E61-5 and ground under following conditions. Other than conditions A and B in Step 1: 10 – 14 V Under condition A or B in Step 1: 0 – 1 V Are check results as specified?	Fuse 29 blown, faulty "R/B", "R/BI", or "B" wire, faulty A/C condenser fan motor or relay.	Fuse 23 blown, faulty "Y/G", "Y/BI" wire or A/C condenser fan relay. If OK, substitute a known-good ECM (PCM) and recheck.

## SPECIAL TOOLS

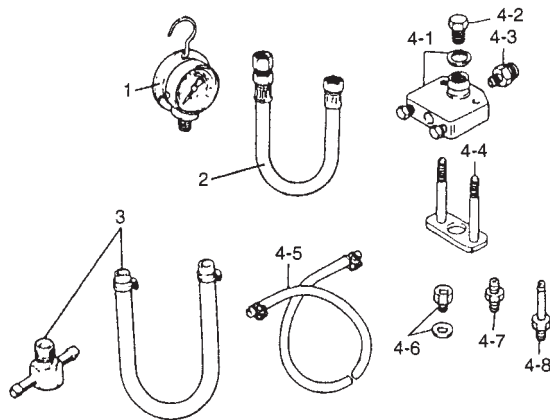

1. Pressure gauge  
09912-58441
2. Pressure hose  
09912-58431
3. 3-way joint & hose  
09912-58490
4. Checking tool set  
09912-58421
- 4-1. Tool body & washer
- 4-2. Body plug
- 4-3. Body attachment-1
- 4-4. Holder
- 4-5. Return hose & clamp
- 4-6. Body attachment-2 & washer
- 4-7. Hose attachment-1
- 4-8. Hose attachment-2

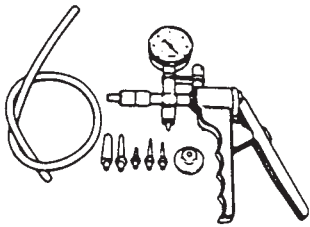

09917-47010  
Vacuum pump gauge

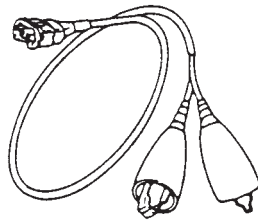

09930-88521  
Injector test lead

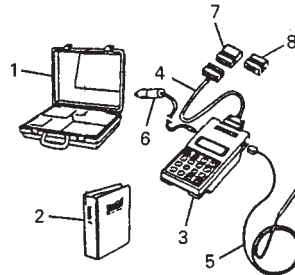

09931-76011  
SUZUKI scan tool (Tech 1)

1. Storage case
2. Operator's manual
3. Tech 1A
4. DLC cable
5. Test lead/probe
6. Power source cable
7. DLC cable adaptor
8. Self-test adaptor

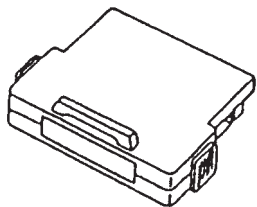

SUZUKI scan tool  
mass storage cartridge

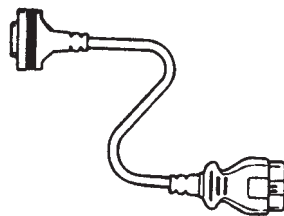

09931-76030  
16/14 pin DLC cable

# SECTION 6A2

## ENGINE MECHANICAL (H25 ENGINE)

**WARNING:**

For vehicles equipped with Supplemental Restraint (Air Bag) System:

- Service on and around the air bag system components or wiring must be performed only by an authorized SUZUKI dealer. Refer to “Air Bag System Components and Wiring Location View” under “General Description” in air bag system section in order to confirm whether you are performing service on or near the air bag system components or wiring. Please observe all WARNINGS and “Service Precautions” under “On-Vehicle Service” in air bag system section before performing service on or around the air bag system components or wiring. Failure to follow WARNINGS could result in unintentional activation of the system or could render the system inoperative. Either of these two conditions may result in severe injury.
- Technical service work must be started at least 90 seconds after the ignition switch is turned to the “LOCK” position and the negative cable is disconnected from the battery. Otherwise, the system may be activated by reserve energy in the Sensing and Diagnostic Module (SDM).

## CONTENTS

<b>GENERAL DESCRIPTION</b> .....	6A2- 2
<b>ON-VEHICLE SERVICE</b> .....	6A2- 4
Compression Check .....	6A2- 4
Engine Vacuum Check .....	6A2- 5
Oil Pressure Check .....	6A2- 6
Air Cleaner Element .....	6A2- 7
Throttle Body and Intake Manifold .....	6A2- 8
Exhaust Manifold .....	6A2-14
Cylinder Head Covers .....	6A2-18
Oil Pan and Oil Pump Strainer .....	6A2-19
Timing Chain Cover .....	6A2-22
Oil Pump .....	6A2-24
LH (NO.1) Bank 2nd Timing Chain and Chain Tensioner .....	6A2-27
1st Timing Chain and Chain Tensioner .....	6A2-33
RH (NO.2) Bank 2nd Timing Chain and Chain Tensioner .....	6A2-41
Oil Pump Chain .....	6A2-46
Camshaft and Valve Lash Adjuster .....	6A2-50
Valve Lash Adjuster Noise Diagnosis .....	6A2-57
Valves and Cylinder Heads .....	6A2-58
Piston, Piston Rings, Connecting Rods and Cylinders .....	6A2-69
<b>UNIT REPAIR OVERHAUL</b> .....	6A2-80
Engine Assembly .....	6A2-80
Main Bearings, Crankshaft and Cylinder Block .....	6A2-84
<b>SPECIAL TOOLS</b> .....	6A2-94
<b>REQUIRED SERVICE MATERIAL</b> .....	6A2-95

## GENERAL DESCRIPTION

### ENGINE

The engine is a water-cooled, 60° V6 cylinders, 4 stroke cycle gasoline unit with its DOHC (Double overhead camshaft) valve mechanism arranged for "V" type valve configuration.

The double overhead camshaft is mounted over the cylinder head; it is driven from crankshaft through timing chains, and no push rods are provided in the valve train system.

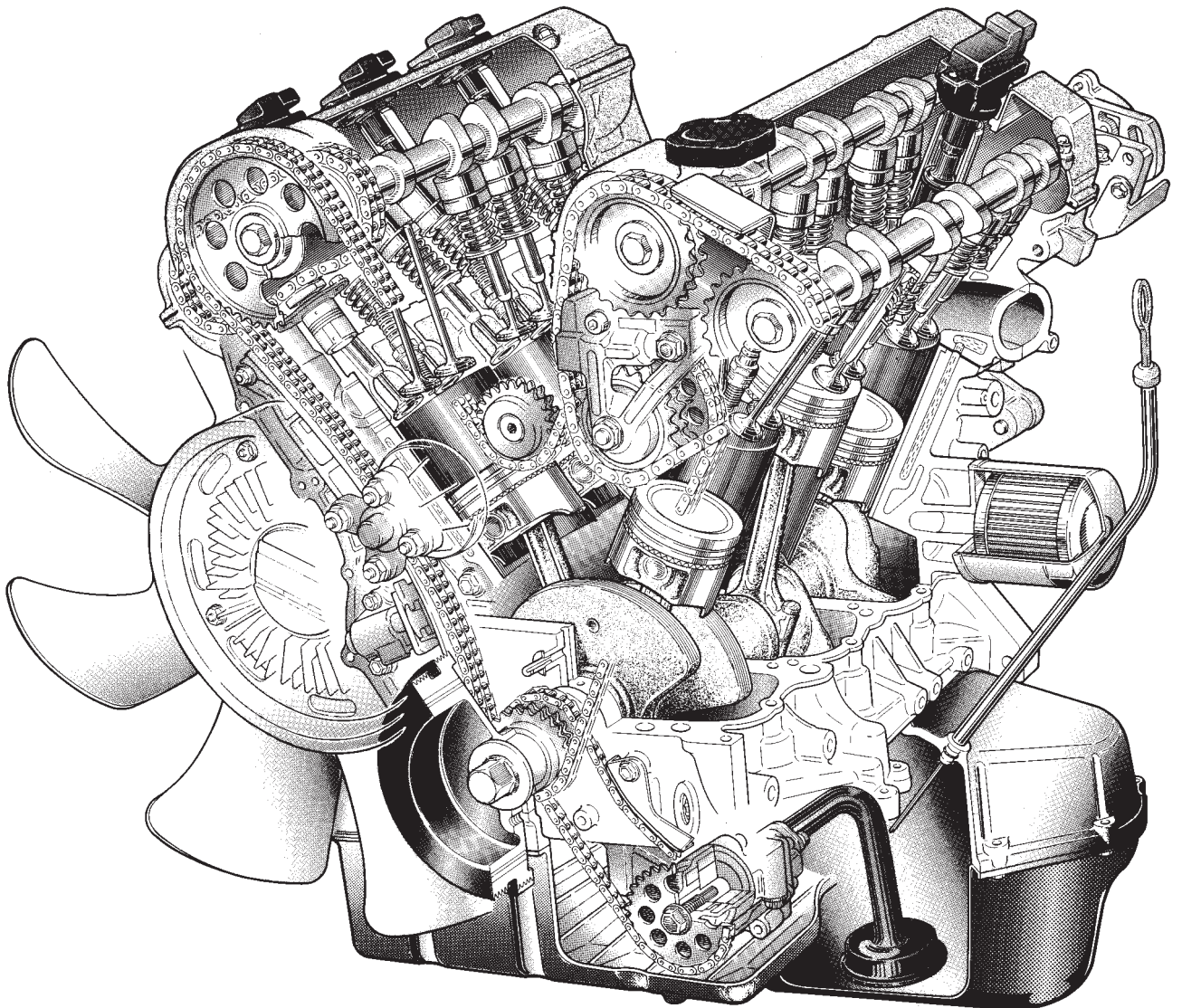

## ENGINE LUBRICATION

The oil pump is of a trochoid type, and mounted under the crankshaft. Oil is drawn up through the oil pump strainer and passed through the pump to the oil filter. The filtered oil flows into 3 paths in cylinder block.

In one path, oil reaches the crankshaft journal bearings. Oil from the crankshaft journal bearings is supplied to the connecting rod bearings by means of intersecting passages drilled in the crankshaft, and then injected from the big end of connecting rod to lubricate piston, rings, and cylinder wall.

In other paths oil goes up to the cylinder heads and lubricates valves and camshafts, etc., after passing through the internal oilway of camshafts.

An oil relief valve is provided on the oil pump. This valve starts relieving oil pressure when the pressure exceeds about 430 kPa (4.3 kg/cm<sup>2</sup>, 61.1 psi).

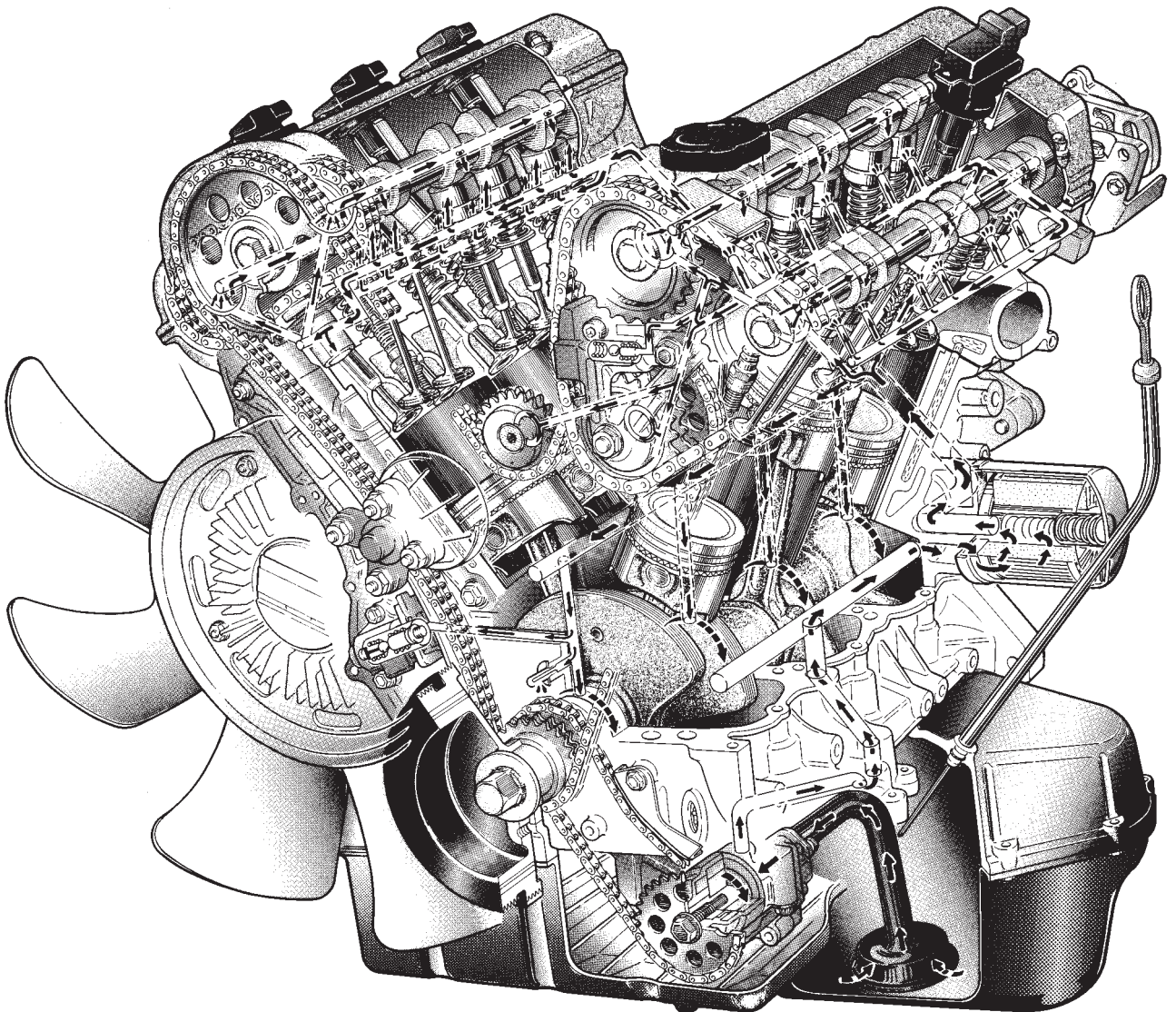

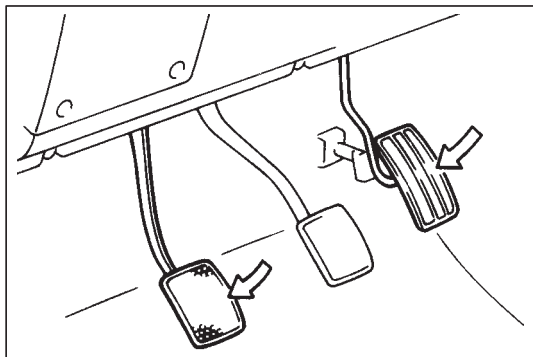
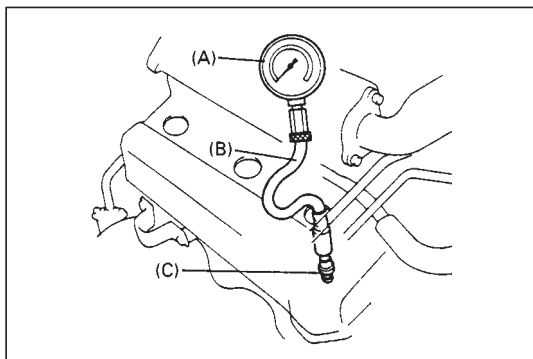
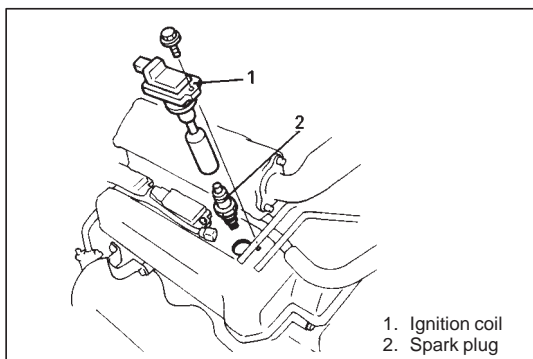

## ON-VEHICLE SERVICE COMPRESSION CHECK

Check compression pressure on all 6 cylinders as follows:

- 1) Warm up engine.
- 2) Stop engine after warming up.
- 3) Remove ignition coil covers and disconnect ignition coil harness couplers.
- 4) Remove all ignition coils and spark plugs.
- 5) Remove surge tank cover.
- 6) Disconnect fuel injector wire harness at connector.
- 7) Install special tool (Compression gauge) into spark plug hole.

### Special Tool

(A): 09915-64510

(B): 09915-64530

(C): 09915-67010

- 8) Disengage clutch (to lighten starting load on engine) for M/T vehicle, and depress accelerator pedal all the way to make throttle fully open.

- 9) Crank engine with fully charged battery, and read the highest pressure on compression gauge.

### NOTE:

**For measuring compression pressure, crank engine at least 250 r/min (rpm) by using fully charged battery.**

### Compression pressure

**Standard: 14.0 – 16.0 kg/cm<sup>2</sup>**

**(199.0 – 227.5 psi, 1400 – 1600 kPa)**

**Limit: 13.0 kg/cm<sup>2</sup> (185.0 psi, 1300 kPa)**

**Max. difference between any two cylinders:**

**1.0 kg/cm<sup>2</sup> (14.2 psi, 100 kPa)**

- 10) Carry out steps 7), 8) and 9) on each cylinder to obtain 6 readings.

## ENGINE VACUUM CHECK

The engine vacuum that develops in the intake line is a good indicator of the condition of the engine. The vacuum checking procedure is as follows:

- 1) Warm up engine to normal operating temperature and make sure that engine idle speed is within specification.

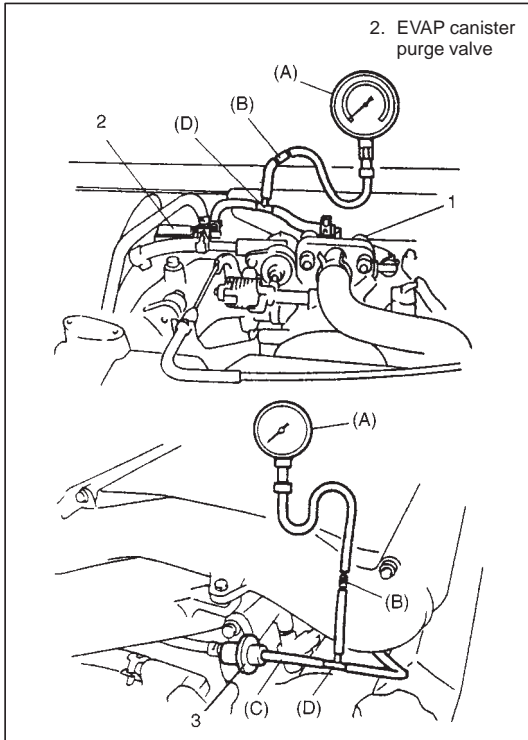

- 2) Stop engine and disconnect vacuum hoses from fuel pressure regulator valve (3) or intake collector (1) to EVAP canister purge valve (2).
- 3) Connect special tools (Vacuum gauge and hose joint) and 3way joint between vacuum hose and valve.

### Special Tool

(A): 09915-67310

(B): 09918-08210

### SUZUKI GENUINE PARTS

(C): Hose 09343-03087

(D): 3way joint 09367-04002

- 4) Start engine and run engine at specified idle speed, and read vacuum gauge. Vacuum should be within specification.

**Vacuum specification: 450 – 600 mm Hg**

**(sea level) (17.7 – 23.7 in.Hg)**

**at specified idle speed**

- 5) After checking, remove vacuum gauge and hose joint.
- 6) Connect vacuum hoses to fuel pressure regulator valve.

## OIL PRESSURE CHECK

### NOTE:

Prior to checking oil pressure, check the followings.

- Oil level in oil pan  
If oil level is low, add oil up to Full level hole on oil level gauge.
- Oil quality  
If oil is discolored, or deteriorated, change it.  
For particular oil to be used, refer to Section 0B.
- Oil leaks  
If leak is found, repair it.

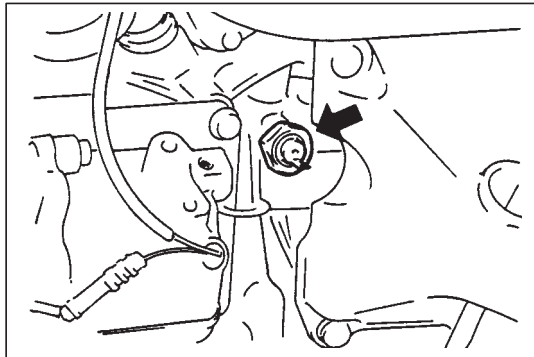

- 1) Remove oil pressure switch from cylinder block.

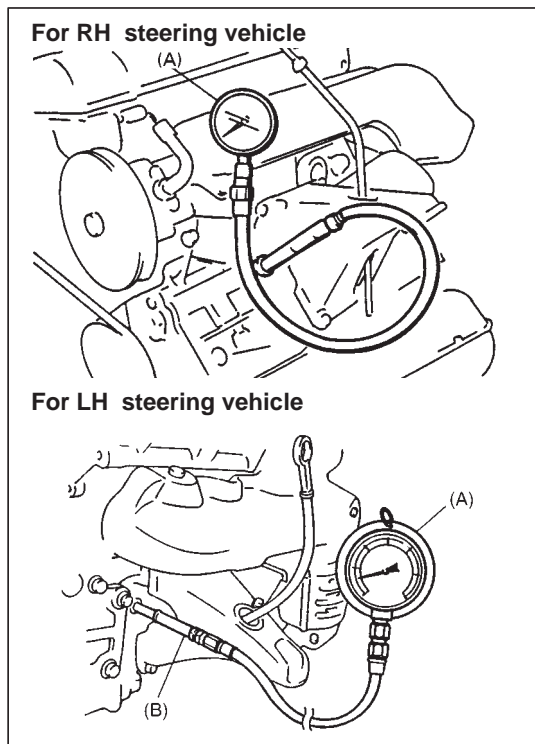

- 2) Install special tool (Oil pressure gauge) to vacated threaded hole.  
For LH steering vehicle, use oil pressure gauge (special tool (A)) with special tool (B) instead of the steel adaptor supplied in special tool (A).

### Special Tool

(A): 09915-77310

(B): 09915-76510

- 3) Start engine and warm it up to normal operating temperature.
- 4) After warming up, raise engine speed to 4,000 r/min. (rpm) and measure oil pressure.

### Oil pressure specification:

**390 – 470 kPa (3.9 – 4.7 kg/cm<sup>2</sup>, 55.5 – 66.8 psi) at 4,000 r/min (rpm)**

- 5) After checking oil pressure, stop engine and remove oil pressure gauge.

- 6) Before reinstalling oil pressure switch, be sure to wrap its screw threads with sealing tape and tighten switch to specified torque.

### Tightening Torque

(a): 14 N·m (1.4 kg-m, 10.0 lb-ft)

### NOTE:

If sealing tape edge is bulged out from screw threads of switch, cut it off.

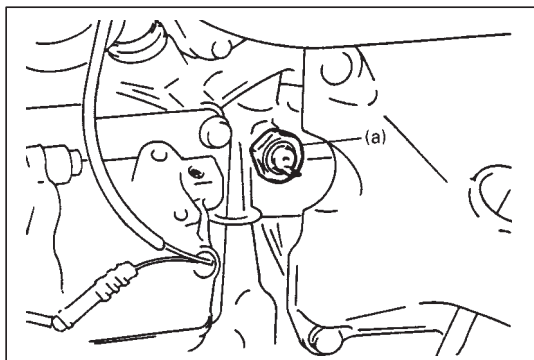

- 7) Start engine and check oil pressure switch for oil leakage.

## AIR CLEANER ELEMENT

This air cleaner element is of dry type. Note that it needs cleaning according to the following method.

### REMOVAL

- 1) Remove air cleaner upper case.
- 2) Remove air cleaner element.

### INSPECTION

Check element for dirt.

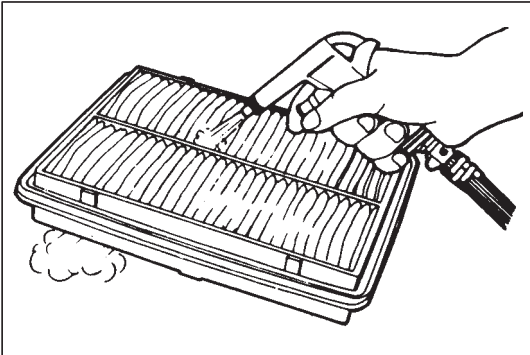
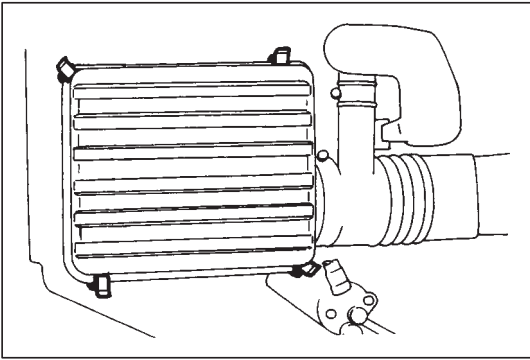

### CLEAN

Blow off dust by blowing compressed air from air outlet side of element (i.e., the side facing up when installed in air cleaner case).

### INSTALLATION

- 1) Install element to air cleaner box.
- 2) Install air cleaner upper case.

## THROTTLE BODY AND INTAKE MANIFOLD

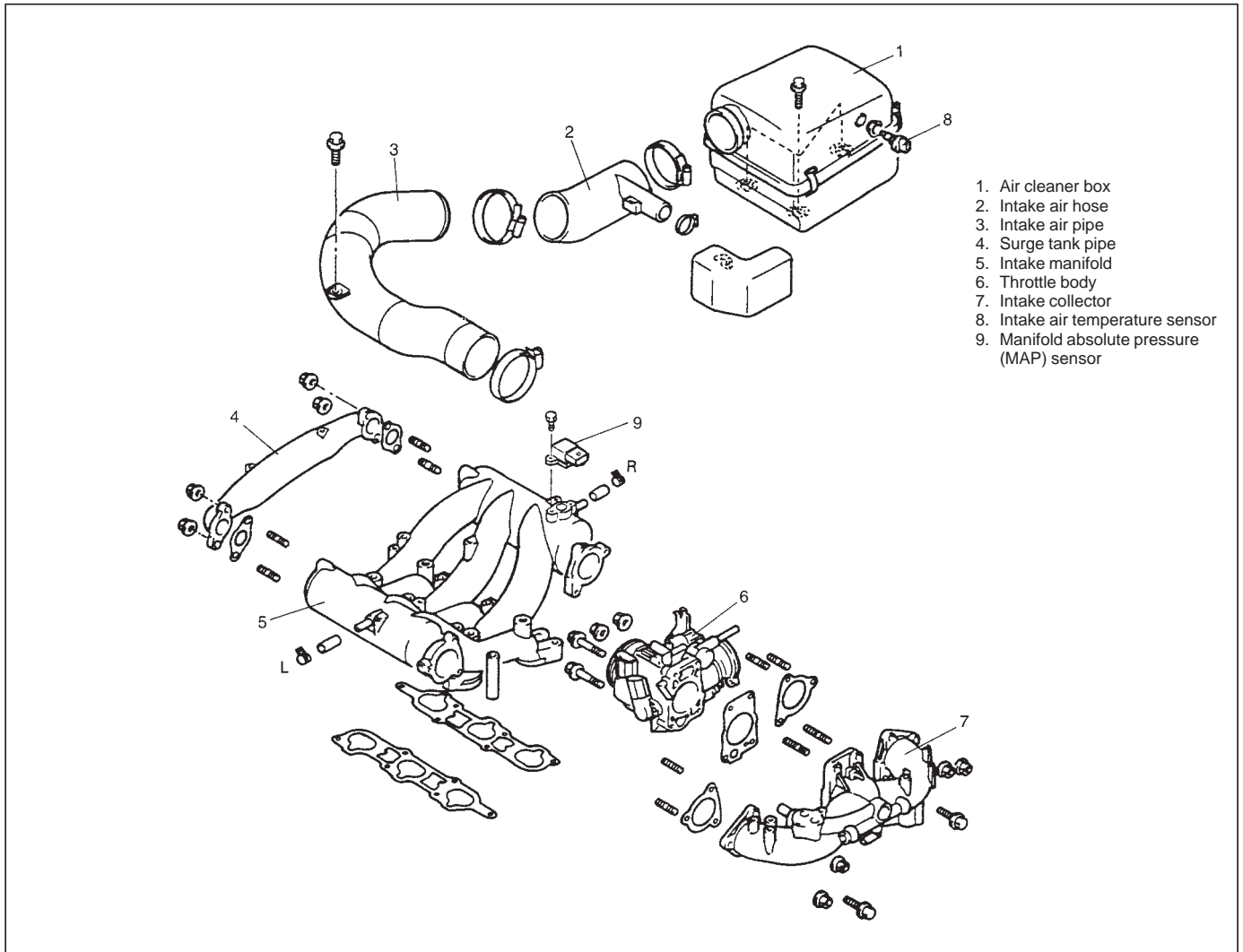

1. Air cleaner box
2. Intake air hose
3. Intake air pipe
4. Surge tank pipe
5. Intake manifold
6. Throttle body
7. Intake collector
8. Intake air temperature sensor
9. Manifold absolute pressure (MAP) sensor

### REMOVAL

- 1) Release fuel pressure in fuel feed line by referring to Section 6.

#### CAUTION:

This work must not be done when engine is hot. If done so, it may cause adverse effect to catalyst.

- 2) Disconnect negative cable at battery.

- 3) Drain coolant.

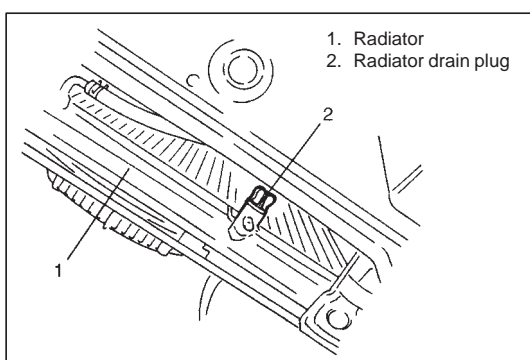

#### WARNING:

To help avoid danger of being burned, do not remove drain plug and radiator cap while engine and radiator are still hot. Scalding fluid and steam can be blown out under pressure if plug and cap are taken off too soon.

- 4) Remove strut tower bar.
- 5) Disconnect coupler from intake air temp. sensor.

6) Remove surge tank cover.

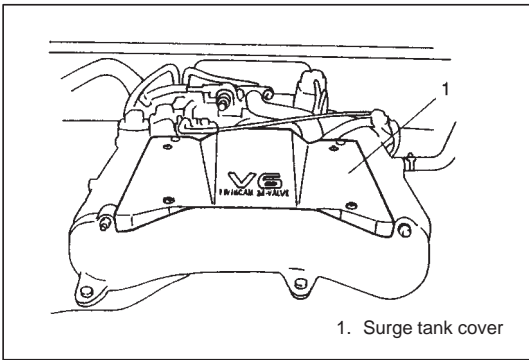

7) Remove air cleaner upper case, intake air hose, intake air pipe and surge tank pipe as one component. Do not disassemble them, when removing and reinstalling.

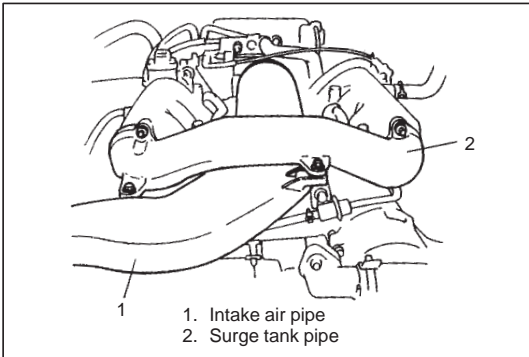

8) Disconnect accelerator cable and A/T throttle cable (for A/T vehicle) from throttle body.

9) Disconnect water hoses from throttle body.

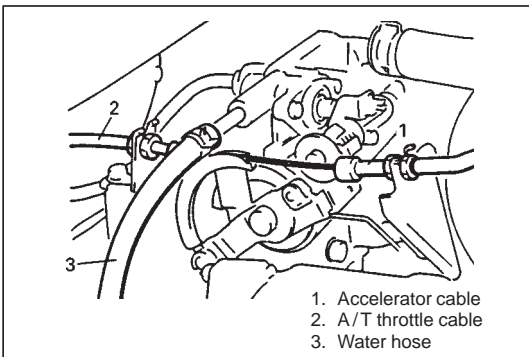

10) Disconnect injector wire coupler.

11) Disconnect brake booster hose from intake manifold.

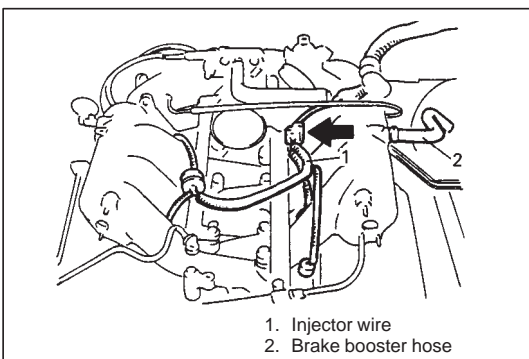

12) Disconnect couplers of TP sensor, MAF sensor and IAC valve.

13) Disconnect earth terminal from intake collector.

14) Remove clamp bracket from intake collector.

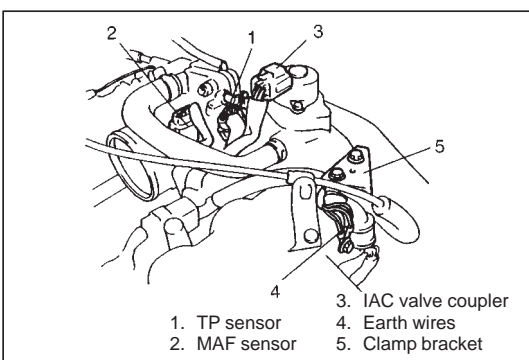

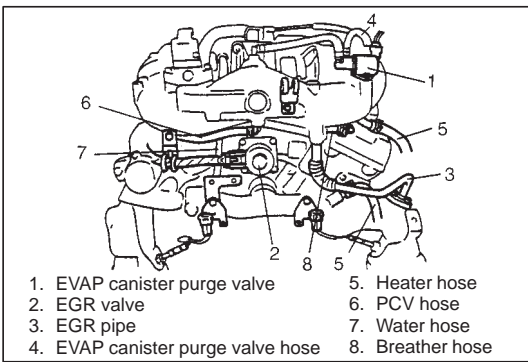

- 15) Disconnect couplers from manifold absolute pressure (MAP) sensor, EVAP canister purge valve and EGR valve.
- 16) Disconnect PCV hose from cylinder head cover. Disconnect breather hoses from throttle body or cylinder head cover.
- 17) Disconnect hoses of EVAP canister purge valve and heater.
- 18) Remove EGR pipe.

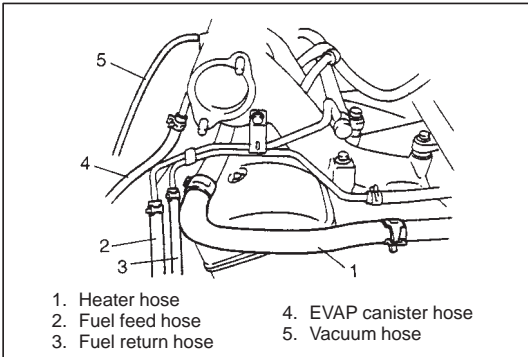

- 19) Disconnect hoses of heater, EVAP canister, tank pressure control solenoid valve, fuel feed and fuel return.

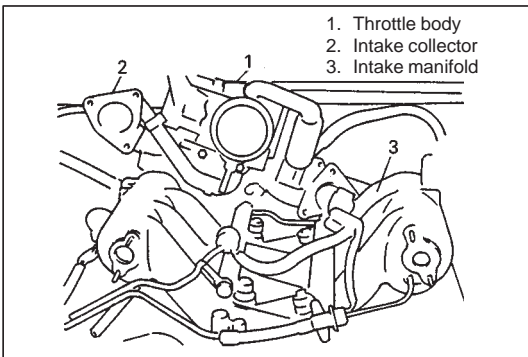

- 20) Remove throttle body and intake collector from intake manifold.

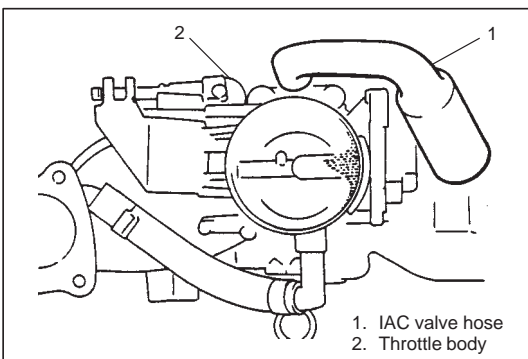

- 21) Disconnect hoses of IAC valve and EVAP canister purge valve from intake collector.
- 22) Remove throttle body from intake collector.
- 23) Remove IAC valve, EGR valve and EVAP canister purge valve from intake collector.

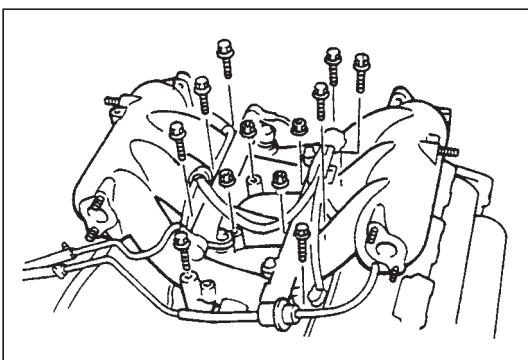

- 24) Remove intake manifold bolts (8 pc.) and nuts (4 pc.).
- 25) Remove intake manifold.

**INSTALLATION**

- 1) Install new intake manifold gaskets to cylinder heads.

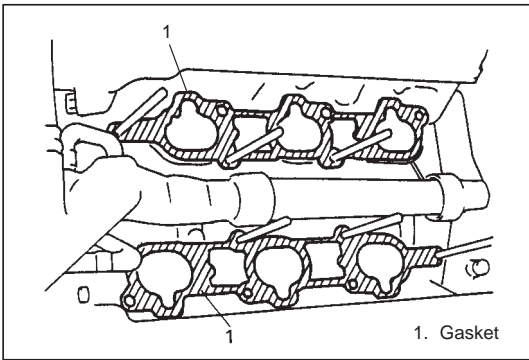

- 2) Install intake manifold.  
Tighten bolts and nuts to specified torque.

**Tightening Torque**

(a): 23.0 N·m (2.3 kg·m, 16.5 lb·ft)

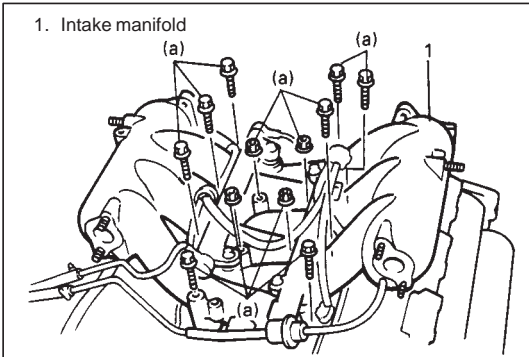

- 3) Install throttle body to intake collector with new throttle body gasket.  
Tighten bolts and nuts to specified torque.

**Tightening Torque**

(b): 23 N·m (2.3 kg·m, 16.5 lb·ft)

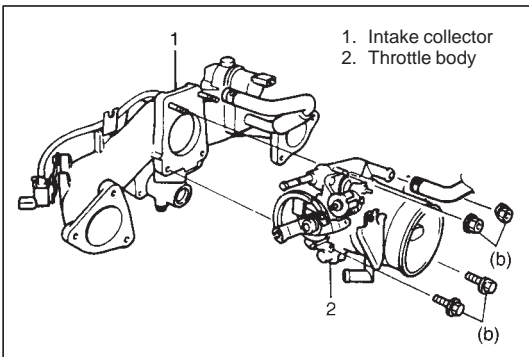

- 4) Install IAC valve, EGR valve, EVAP canister purge valve, manifold absolute pressure (MAP) sensor, clamps and each hoses to intake collector and throttle body if removed.

Use new gasket, when installing IAC valve and EGR valve.

- 5) Install throttle body and intake collector assembly to intake manifold with new intake collector gaskets.

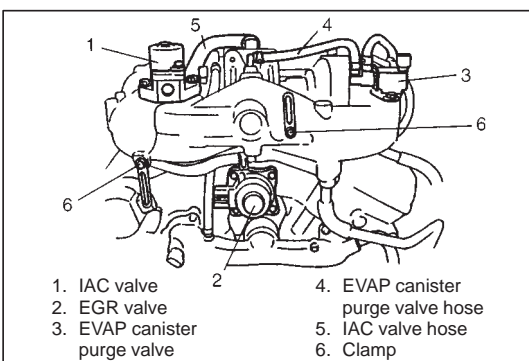

- 6) Connect hoses of heater, EVAP canister, tank pressure control solenoid valve, fuel feed and fuel return.

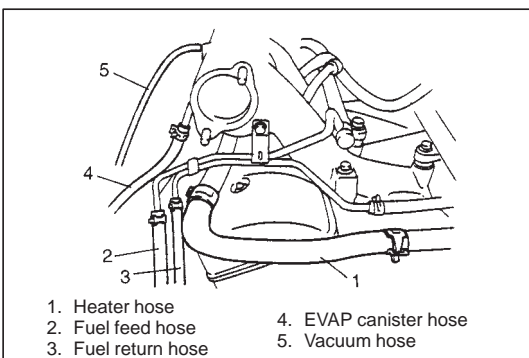

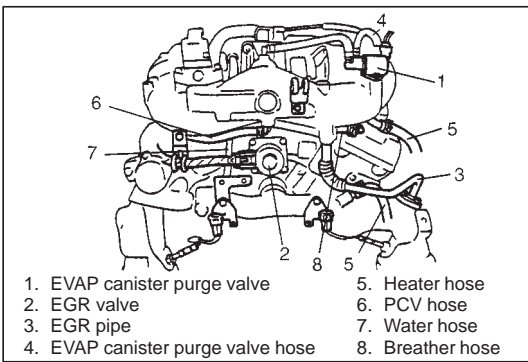

- 7) Install EGR pipe with new gaskets.
- 8) Connect hoses of EVAP canister purge valve and heater.
- 9) Connect hoses of PCV, breather and water.
- 10) Connect couplers of manifold absolute pressure (MAP) sensor, EVAP canister purge valve and EGR valve.  
 Fix wire harness with clamps.

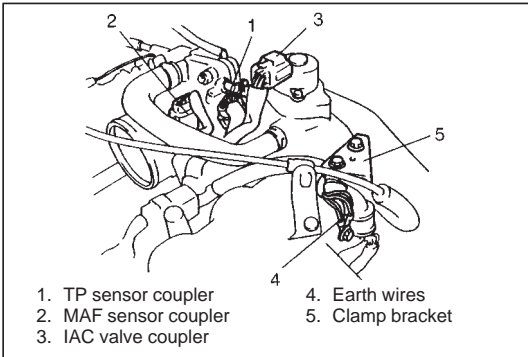

- 11) Install clamp bracket to intake collector.
- 12) Connect earth terminal to intake collector.
- 13) Connect couplers of TP sensor, MAF sensor and IAC valve.

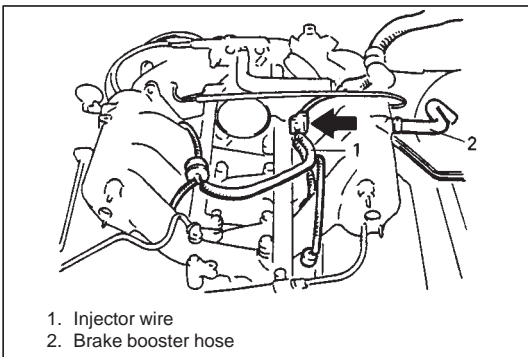

- 14) Connect brake booster hose to intake manifold.
- 15) Connect injector wire coupler.

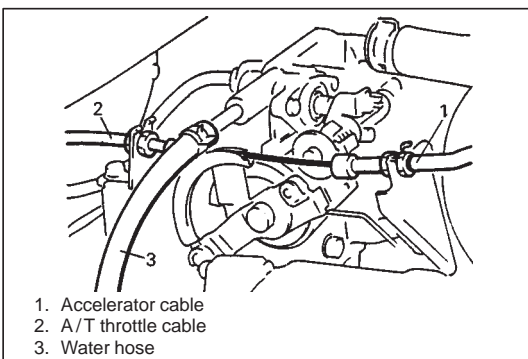

- 16) Connect water hoses to throttle body.
- 17) Connect accelerator cable and A/T throttle cable (for A/T vehicle) to throttle body.

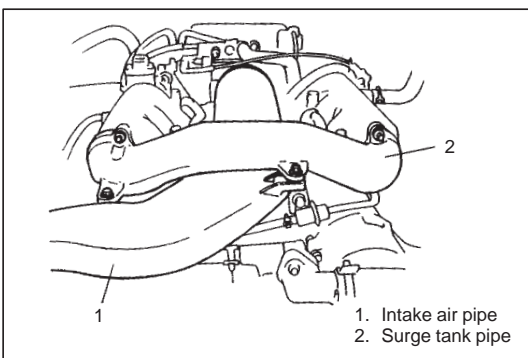

- 18) Install surge tank pipe to intake manifold with new gaskets and intake air pipe to throttle body.

19) Install surge tank cover.

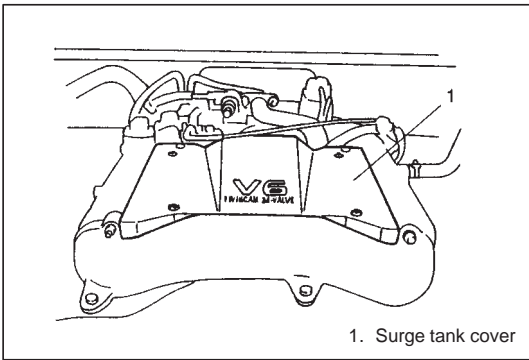

20) Install air cleaner upper case.

21) Connect coupler to intake air temp. sensor.

22) Install strut tower bar.

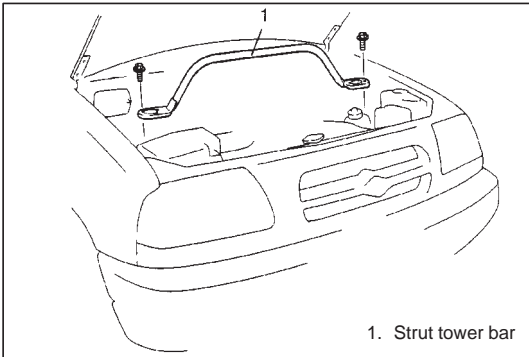

- 23) Check to ensure that all removed parts are back in place.  
Reinstall any necessary parts which have not been reinstalled.
- 24) Refill cooling system, referring to Section 6B.
- 25) Connect negative cable at battery.
- 26) Upon completion of installation, verify that there is no fuel leakage at each connection according to procedure described in Section 6.

Type 1

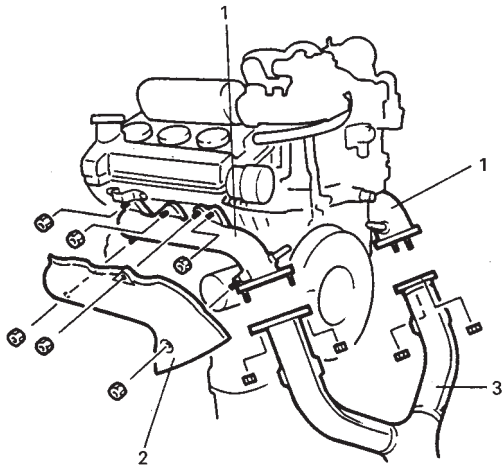

Type 2

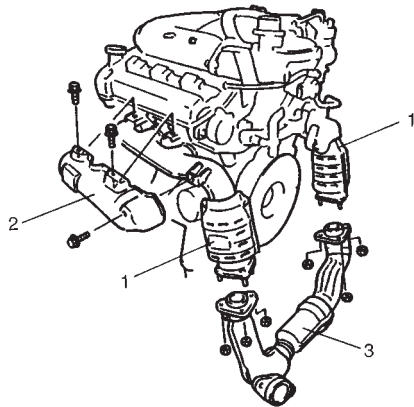

1. Exhaust manifold
2. Exhaust manifold cover
3. Exhaust No.1 pipe

## EXHAUST MANIFOLD

### WARNING:

To avoid danger of being burned, do not service exhaust system while it is still hot. Service should be performed after system has cooled off.

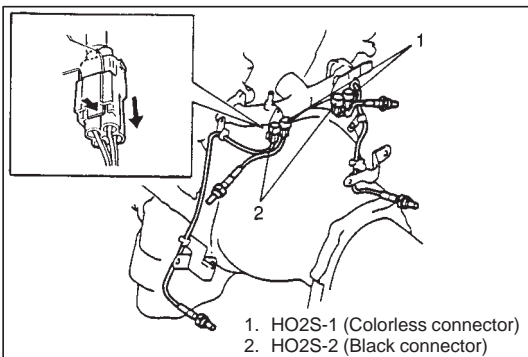

1. HO2S-1 (Colorless connector)
2. HO2S-2 (Black connector)

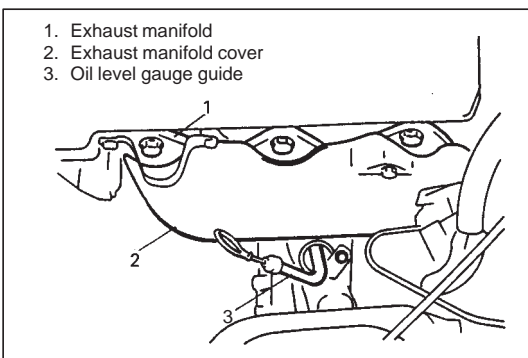

1. Exhaust manifold
2. Exhaust manifold cover
3. Oil level gauge guide

### REMOVAL

- 1) Disconnect negative cable at battery.
- 2) Remove air cleaner upper case and intake air hose.
- 3) Detach couplers from their bracket and disconnect oxygen sensor lead wires at couplers.
- 4) Remove oil level gauge guide.
- 5) Disconnect EGR pipe from right (No.2) bank exhaust manifold.
- 6) Remove exhaust manifold covers from exhaust manifolds.

### NOTE:

Detach EVAP canister from its bracket if necessary.

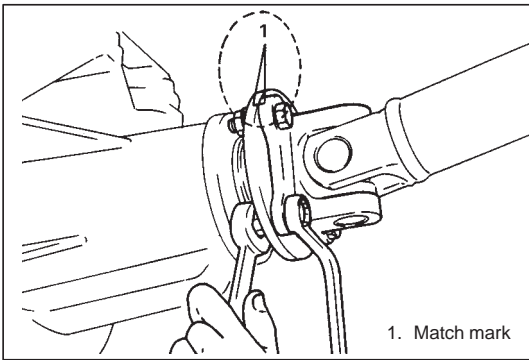

7) Hoist vehicle.

8) For 4WD vehicle, before disconnecting front propeller shaft, put match mark on joint flange and propeller shaft to facilitate their installation as shown in figure.

9) For 4WD vehicle, disconnect propeller shaft from front differential.

10) Remove exhaust No.1 pipe.

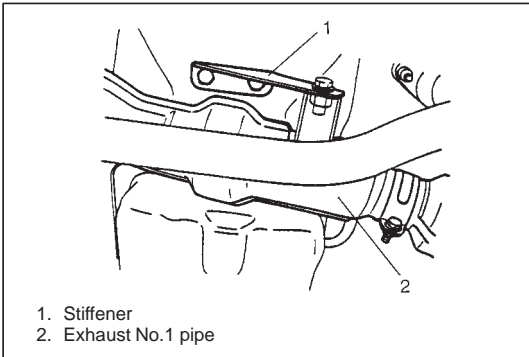

11) Detach exhaust manifold stiffener from transmission case.

12) Remove exhaust manifolds and their gaskets from cylinder heads.

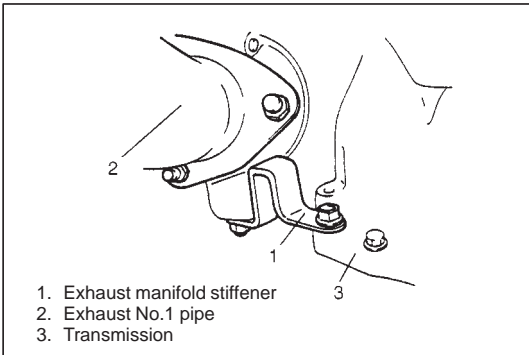

## INSTALLATION

1) Install new manifold gaskets to cylinder heads and No.1 pipe gasket to exhaust No.1 pipe.

2) Install exhaust manifolds.

- Always install new bolts with pre-coated adhesive to the locations with ★ mark.
- Tighten both manifold nuts and bolts to specified torque.

### Tightening Torque

(a): 30 N·m (3.0 kg·m, 21.5 lb-ft)

3) Attach exhaust manifold stiffener to transmission.

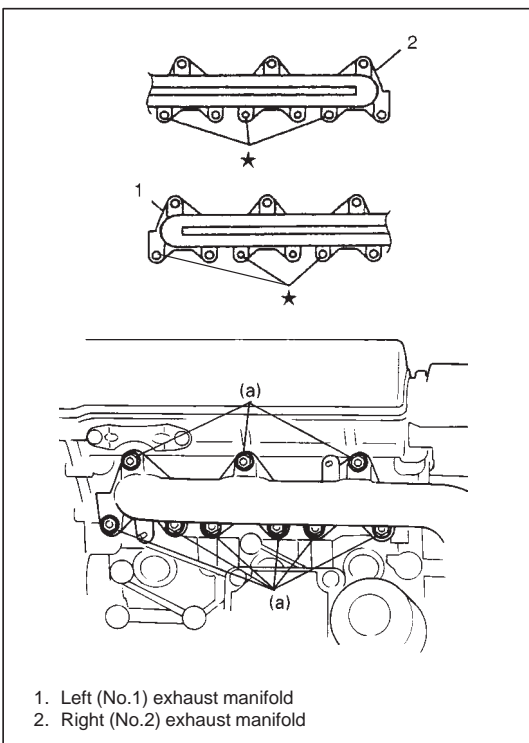

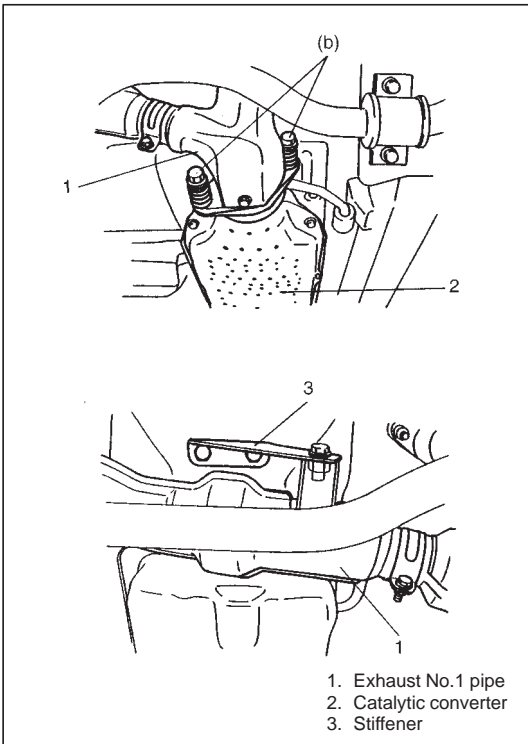

- 4) Install exhaust No.1 pipe and stiffener.  
Tighten exhaust No.1 pipe bolts and nuts to specified torque.

**Tightening Torque**

**(b): 50 N·m (5.0 kg·m, 36.5 lb-ft)**

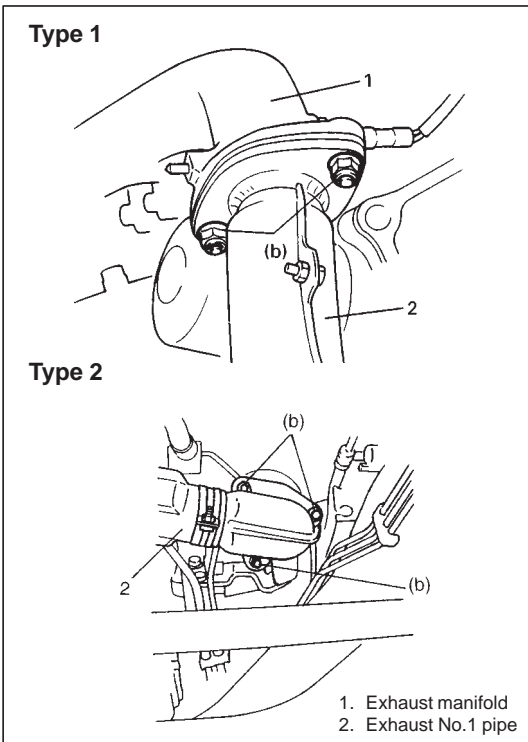

**Tightening Torque**

**(b): 50 N·m (5.0 kg·m, 36.5 lb-ft)**

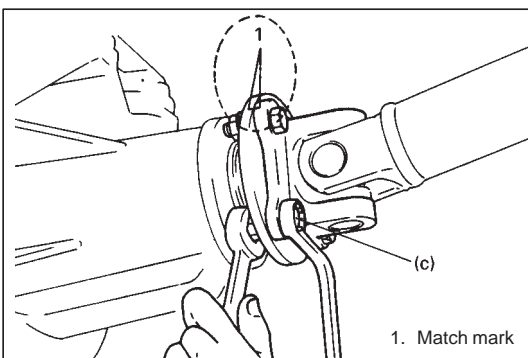

- 5) Reverse removal procedure to install front propeller shaft if removed.

When installing propeller shaft, align match mark.

Use following specification to torque universal joint flange.

**Tightening Torque**

**(c): 55 N·m (5.5 kg·m, 40.0 lb-ft)**

1. Exhaust manifold
2. Exhaust manifold cover
3. Oil level gauge guide

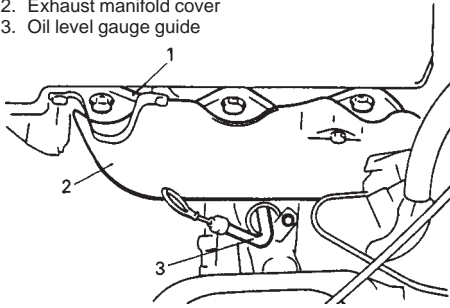

- 6) Connect EGR pipe to left (No.1) bank exhaust manifold.
- 7) Install exhaust manifold covers.
- 8) Install oil level gauge guide using new O-ring.

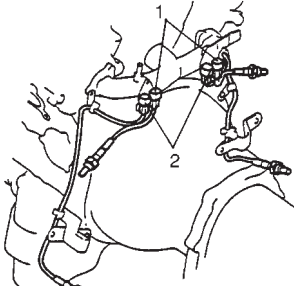

1. HO2S-1 (Colorless connector)
2. HO2S-2 (Black connector)

- 9) Connect oxygen sensor lead wire couplers.  
Be sure to clamp its lead wires.
- 10) Connect negative cable to battery.  
Upon completion of installation, start engine and check that no exhaust gas leakage exists.

## CYLINDER HEAD COVERS

### REMOVAL

- 1) Remove throttle body and intake manifold.  
Refer to item "THROTTLE BODY AND INTAKE MANIFOLD" in this section for removal.
- 2) Remove ignition coil covers.
- 3) Disconnect ignition coil couplers and remove ignition coils.
- 4) Remove cylinder head covers.

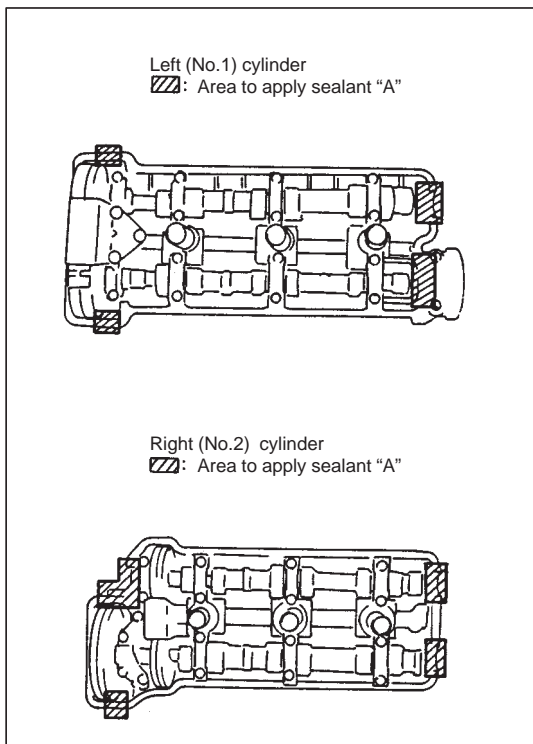
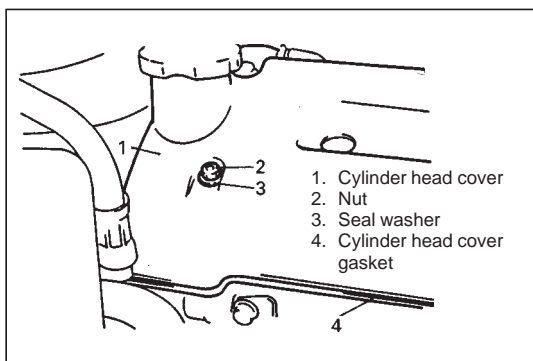

### INSTALLATION

- 1) Clean sealing surfaces on cylinder heads and covers.
- 2) Remove oil, old sealant, and dust from sealing surfaces. After cleaning, apply sealant "A" to cylinder heads sealing surface area as shown in figure.

**"A": Sealant 99000-31150**

- 3) Install new cylinder head cover gaskets to head covers.

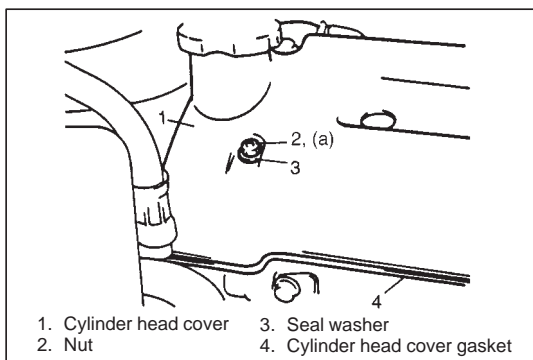

- 4) Install cylinder head covers to cylinder heads.
- 5) Using new seal washers, tighten nuts to specified torque.

#### Tightening Torque

**(a): 10.5 N·m (1.1 kg-m, 7.5 lb-ft)**

- 6) Install ignition coils and connect ignition coil couplers.
- 7) Install ignition coil covers.
- 8) Install throttle body and intake manifold.

Refer to item "THROTTLE BODY AND INTAKE MANIFOLD" in this section for installation.

## OIL PAN AND OIL PUMP STRAINER

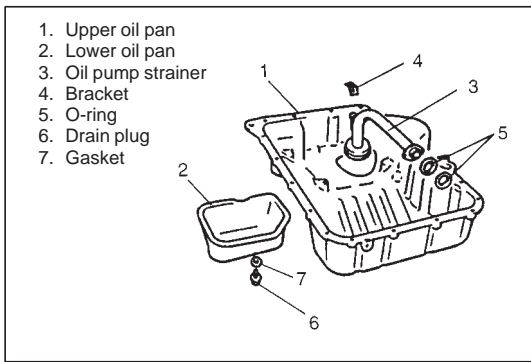

### REMOVAL

- 1) Remove oil level gauge guide.
- 2) Raise vehicle and remove both front wheels.
- 3) Remove rack and pinion assembly.  
Refer to Section 3B1 for removal.

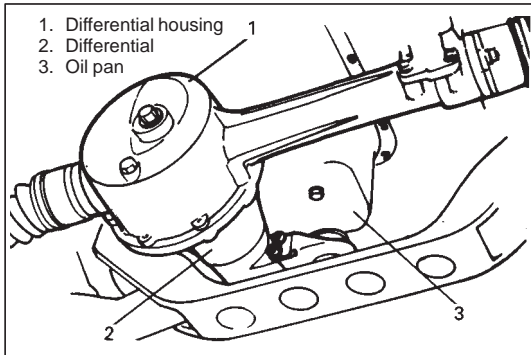

- 4) Remove front differential housing with differential from chassis if equipped.  
Refer to Section 7E for removal.

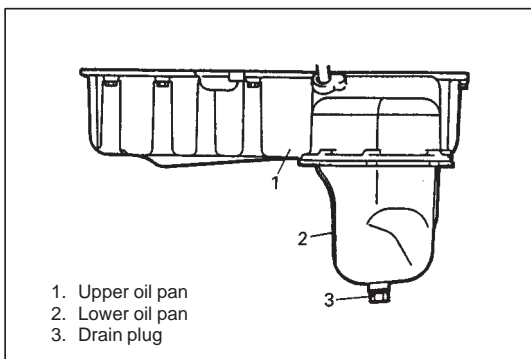

- 5) Drain engine oil by removing drain plug.
- 6) Remove lower oil pan from upper oil pan.
- 7) Remove oil strainer bracket.
- 8) Detach radiator outlet pipe from upper oil pan.

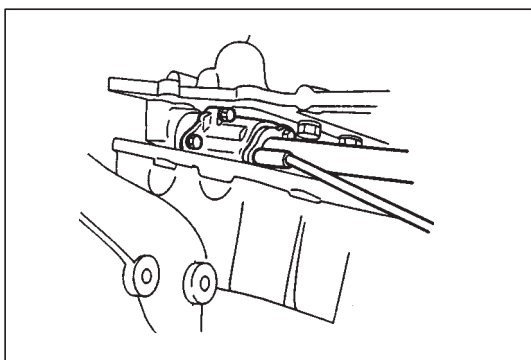

- 9) Remove upper oil pan according to following procedure.  
Lower upper oil pan until it stops by way of cross member and oil pump strainer and keep it at that position temporarily.  
With wrench inserted between upper oil pan and lower crankcase, and oil pump strainer mounting bolt removed, remove oil pump strainer.  
Then remove upper oil pan from temporarily supported position.

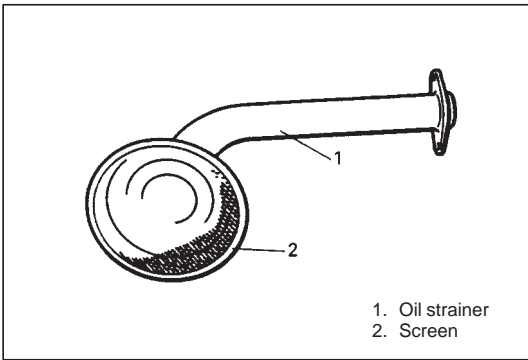

## CLEAN

- Inside of oil pan and oil pump strainer screen.

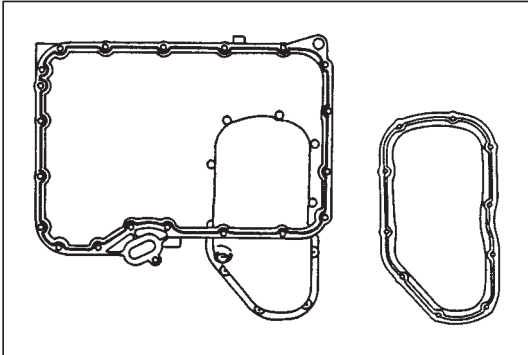

- Clean sealing surface on upper oil pan, lower oil pan and lower crankcase.

Remove oil, old sealant, and dust from sealing surface.

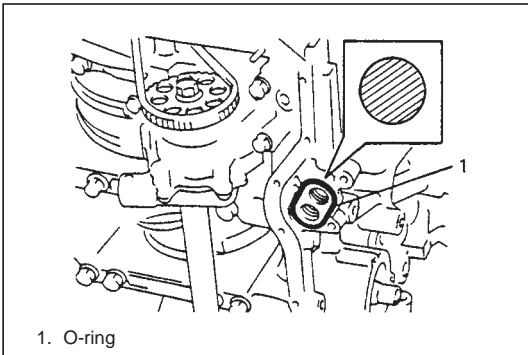

## INSTALLATION

- 1) Install new O-ring to lower crankcase as shown in figure.
- 2) Install two new O-rings to oil pump strainer.

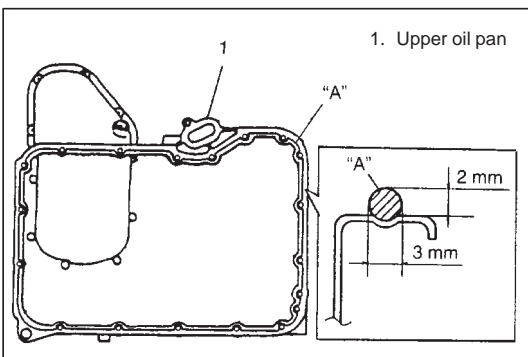

- 3) Apply sealant "A" to upper oil pan sealing surface area as shown in figure.

**"A": Sealant 99000-31150**

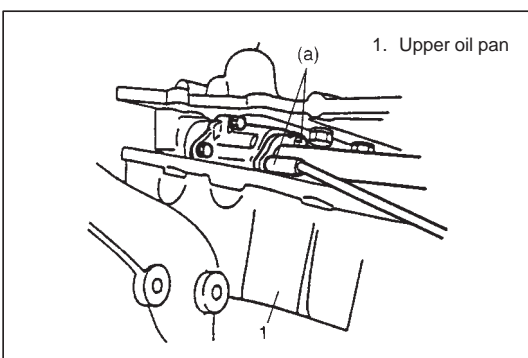

- 4) Place the upper oil pan on the cross member and suspension member (just beneath the lower crankcase). At this point install oil pump strainer.

## Tightening Torque

**(a): 11 N·m (1.1 kg·m, 8.0 lb-ft)**

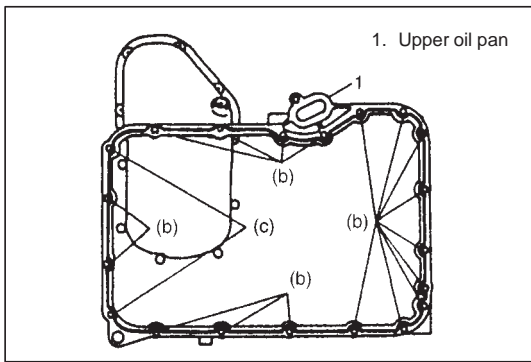

- 5) Install upper oil pan to lower crankcase.

**Tightening Torque**

(b): 11.0 N·m (1.1 kg-m, 8.0 lb-ft)

(c): 27.0 N·m (2.7 kg-m, 19.5 lb-ft)

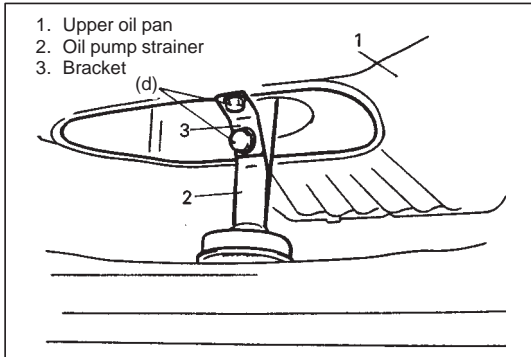

- 6) Install bracket to oil pump strainer and upper oil pan.

**Tightening Torque**

(d): 11 N·m (1.1 kg-m, 8.0 lb-ft)

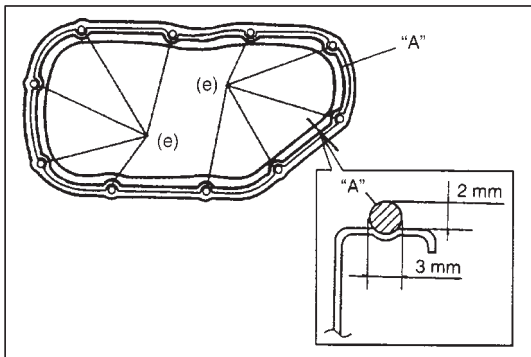

- 7) Apply sealant "A" to lower oil pan sealing surface area as shown in figure.

**"A": Sealant 99000-31150**

- 8) Install lower oil pan to upper oil pan.

**Tightening Torque**

(e): 11 N·m (1.1 kg-m, 8.0 lb-ft)

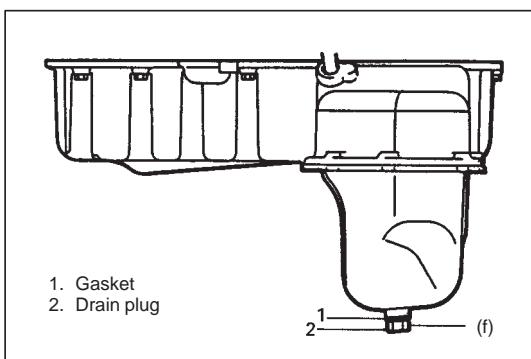

- 9) Install gasket and drain plug to oil pan.

**Tightening Torque**

(f): 35.0 N·m (3.5 kg-m, 25.3 lb-ft)

- 10) Attach radiator outlet pipe to upper oil pan.

- 11) Install front differential housing according to installation procedure described in Section 7E if removed.

- 12) Install rack and pinion assembly.

Refer to Section 3B1 for installation.

- 13) Refill front differential housing with gear oil if drained, referring to Section 7E.

- 14) Install oil level gauge guide with new O-ring.

- 15) Refill engine with engine oil, referring to item "ENGINE OIL CHANGE" in Section 0B.

- 16) Check wheel alignment, referring to Section 3.

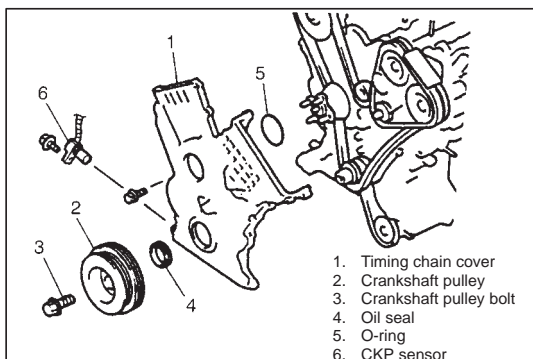

## TIMING CHAIN COVER

### REMOVAL

- 1) Disconnect negative cable at battery.
- 2) Drain engine oil.
- 3) Drain coolant.
- 4) Remove throttle body and intake manifold.  
Refer to item "THROTTLE BODY AND INTAKE MANIFOLD" in this section for removal.
- 5) Remove cylinder head covers.  
Refer to item "CYLINDER HEAD COVER" in this section for removal.
- 6) Remove cooling fan, fan clutch and water pump pulley.  
Refer to Section 6B for removal.
- 7) Remove radiator.  
Refer to Section 6B for removal.
- 8) Remove thermostat cap.  
Refer to Section 6B for removal.
- 9) Remove P/S pump (A/C compressor) drive belt.  
Refer to Section 3B1 for removal.
- 10) Remove water pump drive belt.  
Refer to Section 6B for removal.
- 11) Remove P/S pump and P/S pump bracket.  
Refer to Section 3B1 for removal.
- 12) Raise vehicle.
- 13) Remove oil pan.  
Refer to item "OIL PAN AND OIL PUMP STRAINER" in this section for removal.

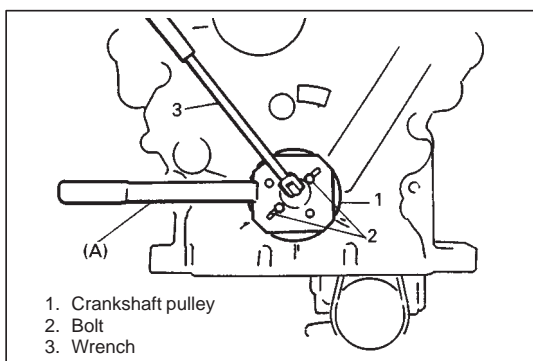

- 14) Remove crankshaft pulley bolt.  
To lock crankshaft pulley, use special tool (camshaft pulley holder) as shown in figure.

#### Special Tool

(A): 09917-68221

#### CAUTION:

Be sure to use the following bolt for fixing special tool to crankshaft pulley.



Bolt size: M8, P1.25  $l = 45$  mm  
Strength: 7T

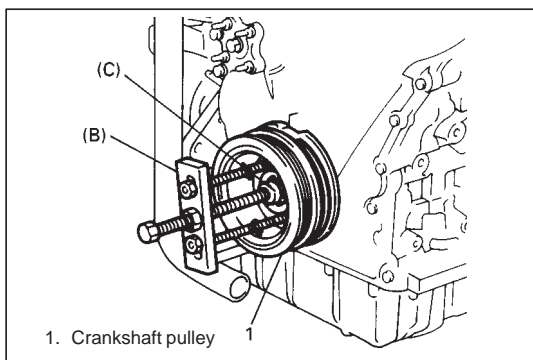

- 15) Remove crankshaft pulley.  
If it is hard to remove, use special tools (Steering wheel remover, Bearing puller attachment) as shown in figure.  
If bolts of steering wheel remover are too long, replace them with those of suitable length.

#### Special Tool

(B): 09944-36011

(C): 09926-58010

- 15-1) Disconnect CKP sensor connector and remove CKP sensor if necessary.
- 16) Remove timing chain cover.

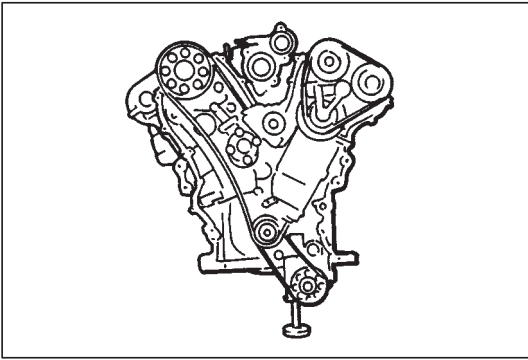

## CLEAN

Clean sealing surface on timing chain cover, crankcase, cylinder block and cylinder heads.

Remove oil, old sealant, and dust from sealing surface.

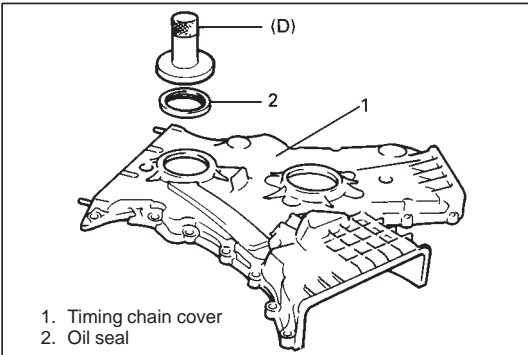

## INSPECTION

Check oil seal lip for damages or deterioration.

Replace as necessary.

## NOTE:

**When installing new oil seal, top it in until its surface is flush with edge of timing chain cover.**

**To install oil seal, use special tool (bearing installer).**

## Special Tool

**(D): 09913-75510**

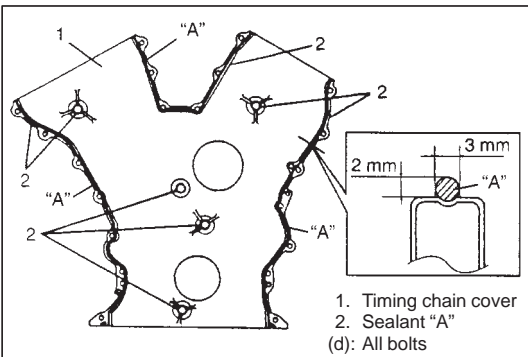

## INSTALLATION

Reverse removal sequence to install timing chain cover noting following points.

1) Apply sealant "A" to timing chain cover sealing surface area as shown in figure.

**"A": Sealant 99000-31150**

2) Apply engine oil to oil seal lip and water pump O-ring, then install timing chain cover.

## Tightening Torque

**(d): 11.0 N·m (1.1 kg-m, 7.5 lb-ft)**

3) Apply engine oil to O-ring of CKP sensor and install CKP sensor to timing chain cover.

## Tightening torque

**(b): 6 N·m (0.6 kg-m, 4.5 lb-ft)**

4) Install crankshaft pulley.

To lock crankshaft pulley, use special tool (camshaft pulley holder) with it at shown in figure.

## Special Tool

**(A): 09917-68221**

## CAUTION:

**Be sure to use the following bolt for fixing special tool to crank pulley.**



**Bolt size: M8, P1.25  $l = 45$  mm  
Strength: 7T**

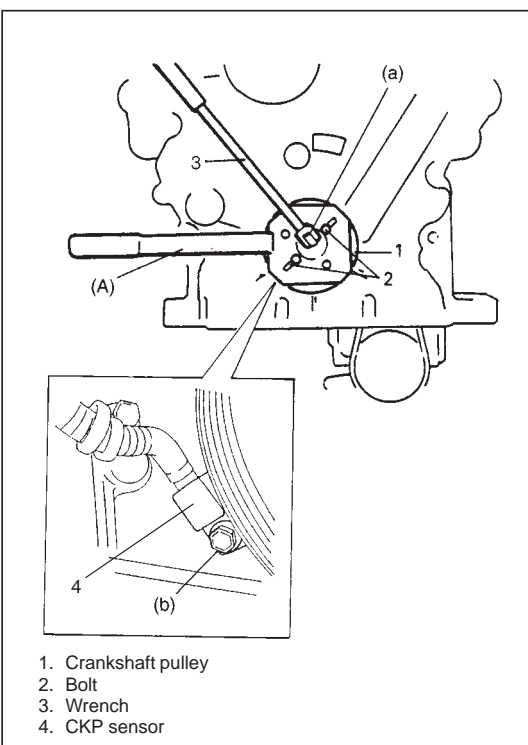

## Tightening Torque

**(a): 150 N·m (15 kg-m, 108.5 lb-ft)**

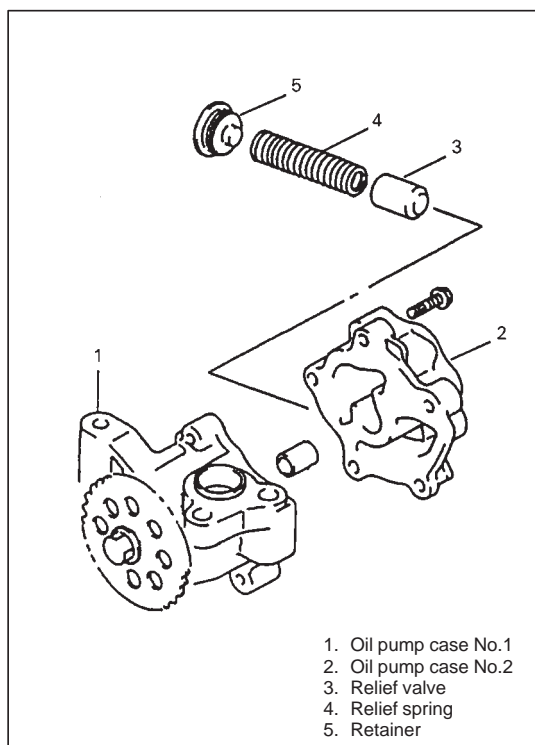
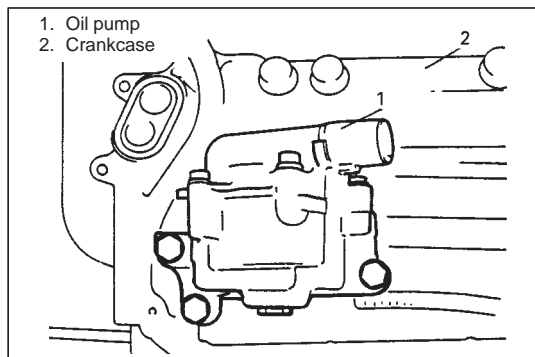
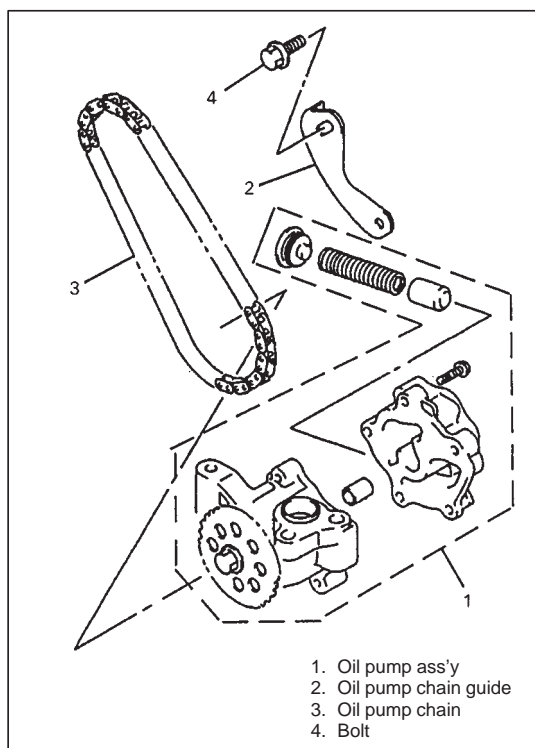

## OIL PUMP

### REMOVAL

- 1) Disconnect negative cable at battery.
- 2) Drain engine oil.
- 3) Drain coolant.
- 4) Remove oil pan, oil pump strainer and timing chain cover.  
Refer to item "TIMING CHAIN COVER" in this section.
- 5) Loosen oil pump chain guide bolts.

- 6) Remove oil pump from crankcase.

#### CAUTION:

**Do not remove oil pump sprocket or bolt.  
Otherwise, oil pump sprocket and/or oil pump rotor shaft  
might be damaged.**

### DISASSEMBLY

Disassemble oil pump as shown in figure.

#### CAUTION:

**Do not remove oil pump sprocket or bolt.  
Otherwise, oil pump sprocket and/or oil pump rotor shaft  
might be damaged.**

### INSPECTION

- Check outer rotor, inner rotor and oil pump cases for excessive wear or damage.
- Check relief valve for excessive wear or damage.

- Measure free length and tension of oil relief spring.

Item	Standard
Spring free length	63.5 mm (2.5 in.)
Spring preload	86.0 N for 52.0 mm (8.6 kg for 52.0 mm 62.2 lb/ 2.05 in.)

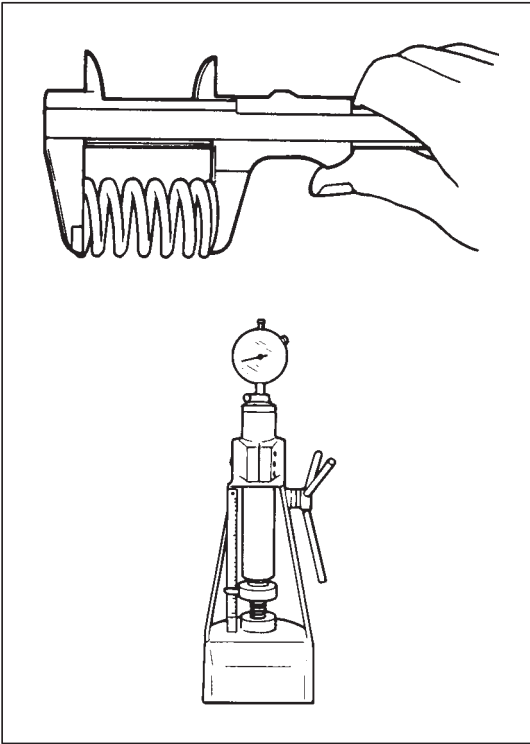

- Measure clearance of oil pump rotor and oil pump case.

#### Radial Clearance

Check radial clearance between outer rotor and case, using thickness gauge.

If clearance exceeds its limit, replace oil pump assembly.

**Limit on radial clearance between  
outer rotor and case: 0.15 mm (0.0059 in.)**

#### Side Clearance

Using straightedge and thickness gauge, measure side clearance.

If clearance exceeds its limit, replace oil pump assembly.

**Limit on side clearance: 0.11 mm (0.0043 in.)**

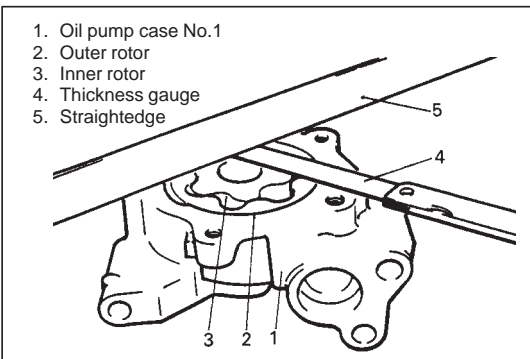
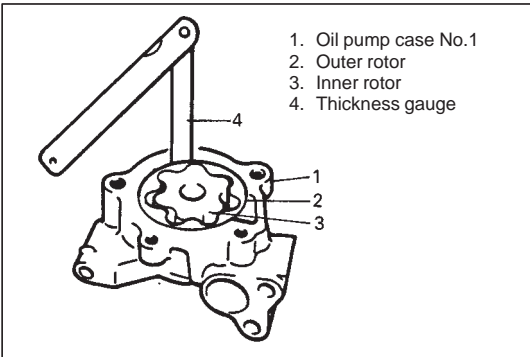

#### ASSEMBLY

- 1) Wash, clean and then dry all disassembled parts.
- 2) Apply thin coat of engine oil to inner and outer rotors, and inside surfaces of oil pump case.

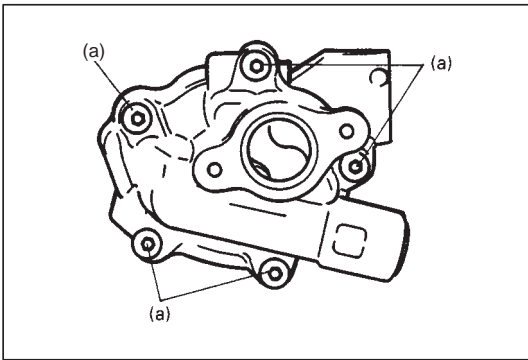

- 3) Assemble oil pump. After assembling oil pump check to be sure that rotor turns smoothly by hand.

**Tightening Torque**

**(a): 12.0 N·m (1.2 kg-m, 8.5 lb-ft)**

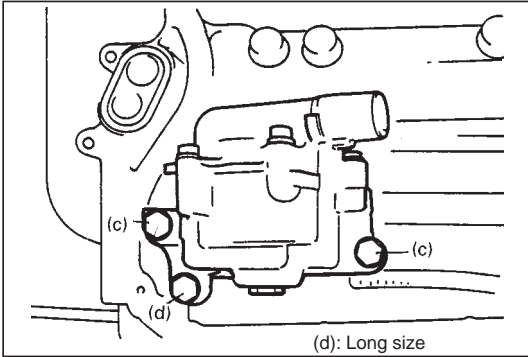

**INSTALLATION**

- 1) Install oil pump to crankcase.

**Tightening Torque**

**(c), (d): 27.0 N·m (2.7 kg-m, 19.5 lb-ft)**

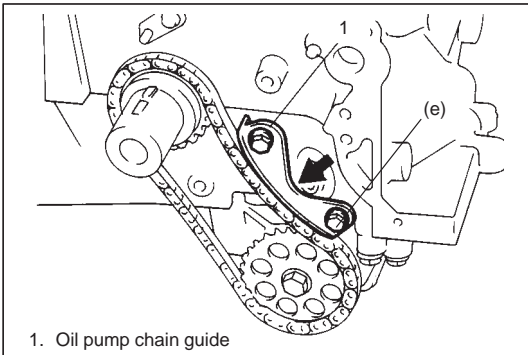

- 2) Hand-tighten oil pump chain guide bolts.  
 3) To take up slack of oil pump chain, push center of oil pump chain guide with a force of 0.5 to 0.6 N (50 – 60 g, 0.11 – 0.13 lb) then tighten oil pump chain guide bolts to specified torque.

**Tightening Torque**

**(e): 11 N·m (1.1 kg-m, 7.5 lb-ft)**

- 4) Install timing chain cover, oil pump strainer and oil pan. Refer to item "TIMING CHAIN COVER" in this section.

## LH (NO.1) BANK 2ND TIMING CHAIN AND CHAIN TENSIONER

1. LH bank 2nd timing chain
2. Timing chain tensioner adjuster No.3
3. LH bank intake camshaft sprocket
4. LH bank exhaust camshaft sprocket
5. Camshaft sprocket bolt
6. Timing chain guide No.4
7. Timing chain guide No.5
8. Idler sprocket No.2

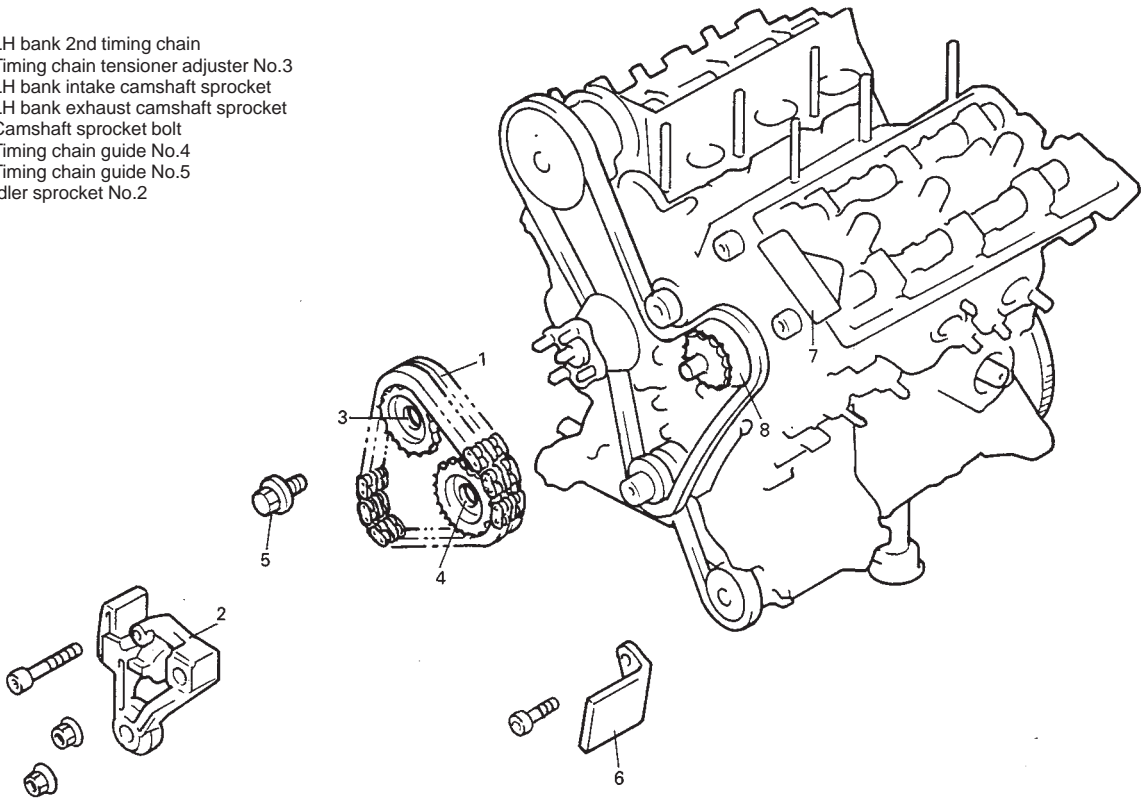

### REMOVAL

- 1) Disconnect negative cable at battery.
  - 2) Drain engine oil.
  - 3) Drain coolant.
  - 4) Remove timing chain cover.  
Refer to item "TIMING CHAIN COVER" in this section for removal.
  - 5) Turn crankshaft to meet following condition.
    - Key (1) on crankshaft positions as shown.
    - Arrow mark on idler sprocket No.2 (2) points the center of crankshaft.
    - The marks on sprockets (3) match with marks on cylinder head.
- Note that this step must be followed for reinstallation of timing chain.

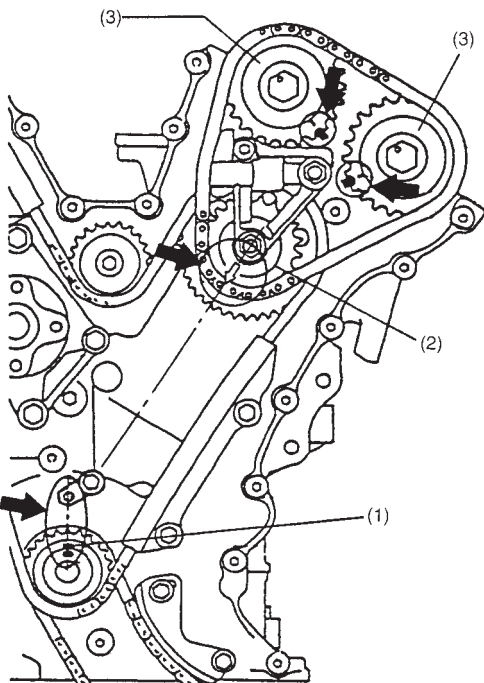

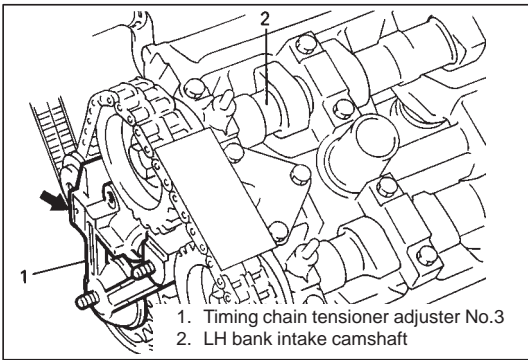

- 6) Remove timing chain tensioner adjuster No.3.  
To remove it, slacken LH bank 2nd timing chain by turning intake camshaft counterclockwise a little while pushing back pad.

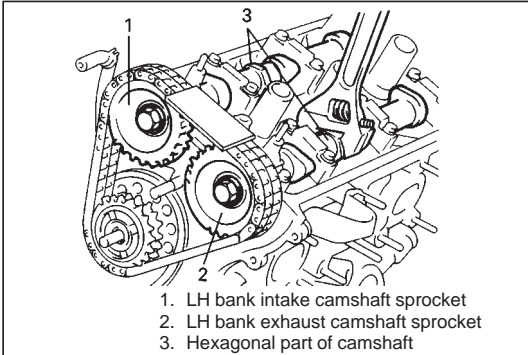

- 7) Remove LH bank intake and exhaust camshaft sprocket bolts.  
To remove it, fit a spanner to hexagonal part at the center of camshaft to hold it stationary.

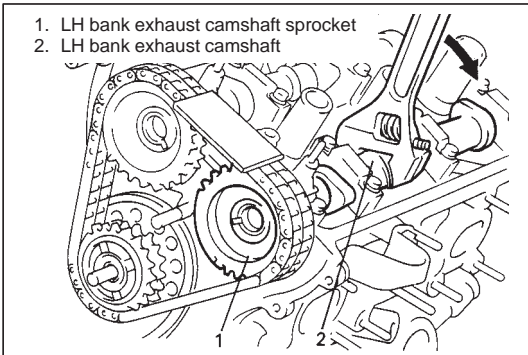

- 8) Remove LH bank exhaust camshaft sprocket.

**CAUTION:**

Removing sprocket from camshaft may cause cam to turn, resulting in damage to valve and piston. To prevent this, when removing sprocket, hold camshaft stationary by using a spanner at its hexagonal part.

- 9) Remove LH bank intake camshaft sprocket.

- 10) Remove LH bank 2nd timing chain.

**INSPECTION****Timing chain guide No.4 and No.5**

Check shoe for wear or damage.

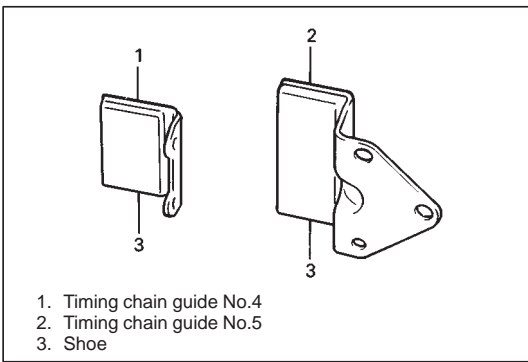
**Camshaft sprocket**

Check teeth of sprocket for wear or damage.

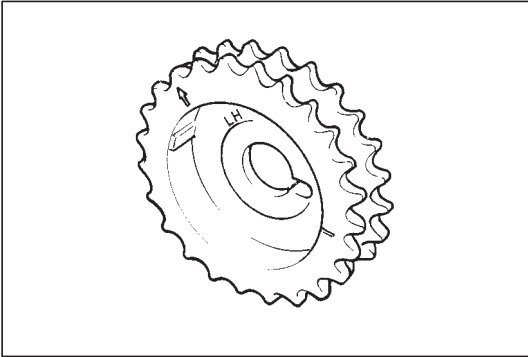
**Timing chain**

Check timing chain for wear or damage.

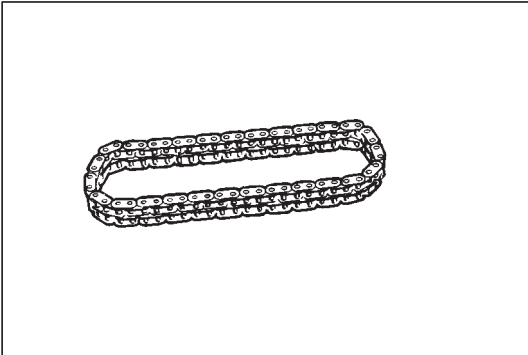
**Tensioner adjuster No.3**

- Check shoe for wear or damage.

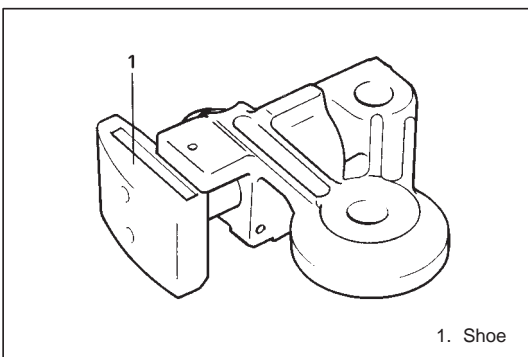

- Check that latch and tooth surface are free from damage and latch functions properly.

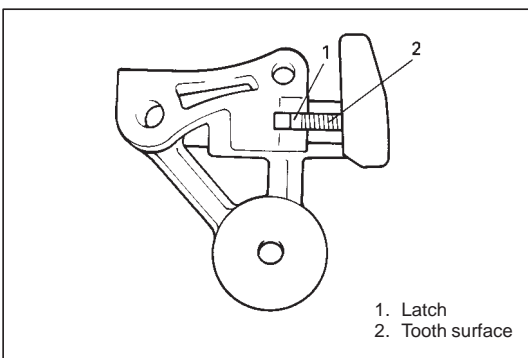

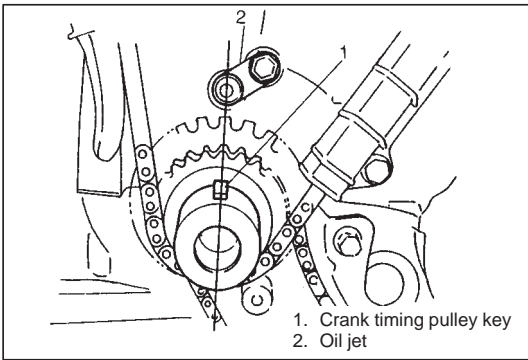

## INSTALLATION

1) Check timing mark on crankshaft as shown in figure.

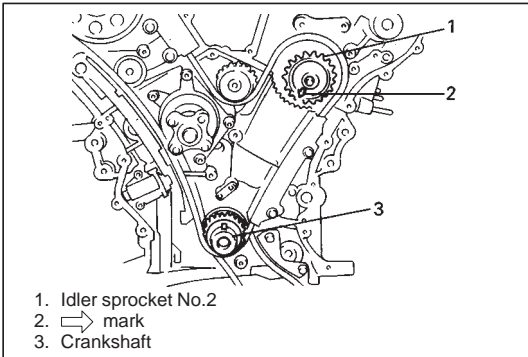

2) Check timing mark on idler sprocket No.2 as shown in figure.

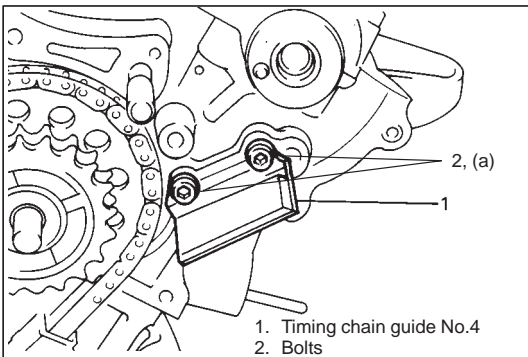

3) Install timing chain guide No.4.

### Tightening Torque

(a): 11 N·m (1.1 kg·m, 7.5 lb·ft)

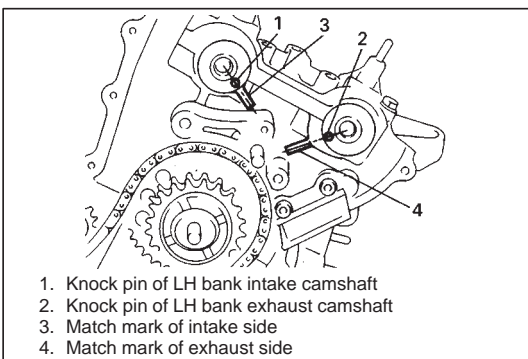

4) Check that knock-pins of intake and exhaust camshafts are aligned with match marks on cylinder head as shown in figure.

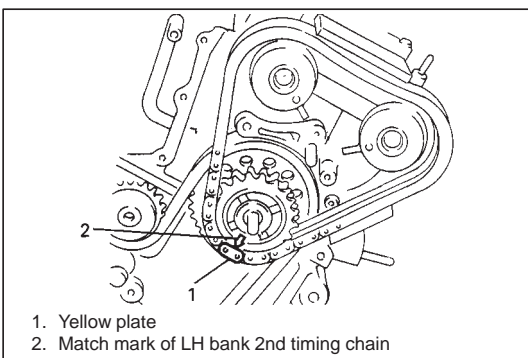

5) Install by aligning match marks on yellow plate of LH bank 2nd timing chain and idler sprocket No.2.

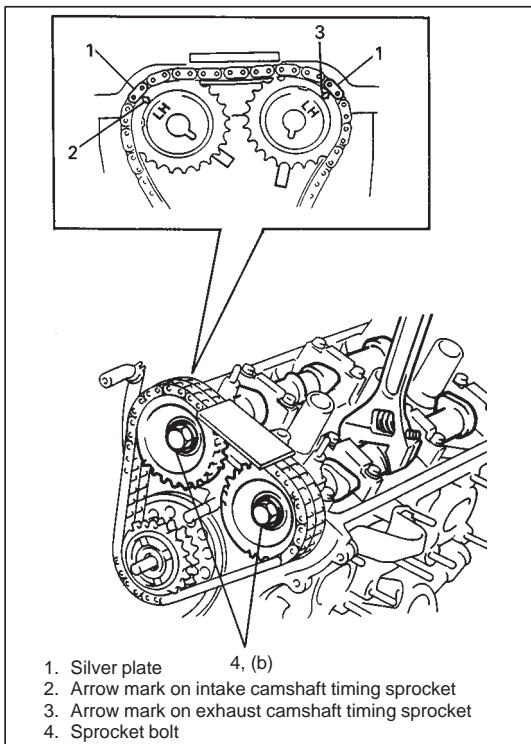

- 6) Install sprockets to intake and exhaust camshafts by aligning silver plate of LH bank 2nd timing chain, match marks on intake sprocket and exhaust sprocket respectively.

**CAUTION:**

**Do not turn camshaft more than necessary.**

**If turned excessively, valve and piston may get damaged.**

- 7) Install LH bank intake and exhaust camshaft timing sprockets. To install it, fit a spanner to hexagonal part at the center of camshaft to hold stationary.

**Tightening Torque**

**(b): 80 N·m (8.0 kg-m, 57.5 lb-ft)**

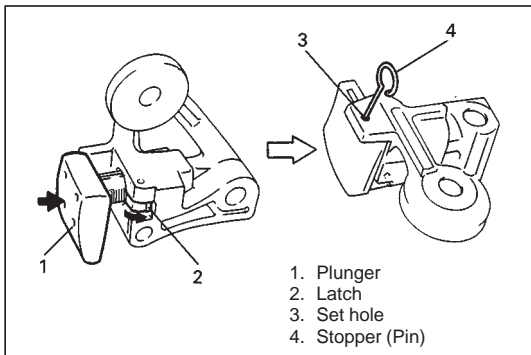

- 8) With latch of tensioner adjuster No.3 returned and plunger pushed back into body, insert stopper (pin) into set hole. After inserting it, check to make sure that plunger will not come out.

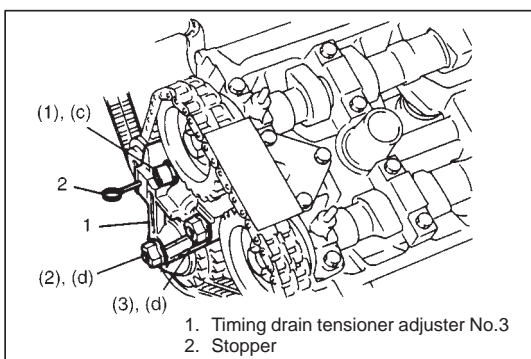

- 9) Install timing chain tensioner adjuster No.3.

**Tightening Torque**

**(c): 25 N·m (2.5 kg-m, 18.0 lb-ft)**

**(d): 45 N·m (4.5 kg-m, 32.5 lb-ft)**

**Tightening order: (1) → (2) → (3)**

- 10) Pull out stopper (pin) from set hole.

- 11) Turn crankshaft two rotations clockwise then align timing mark on crankshaft and timing mark on cylinder block as shown in figure.  
Check each other timing marks that align them shown in figure.

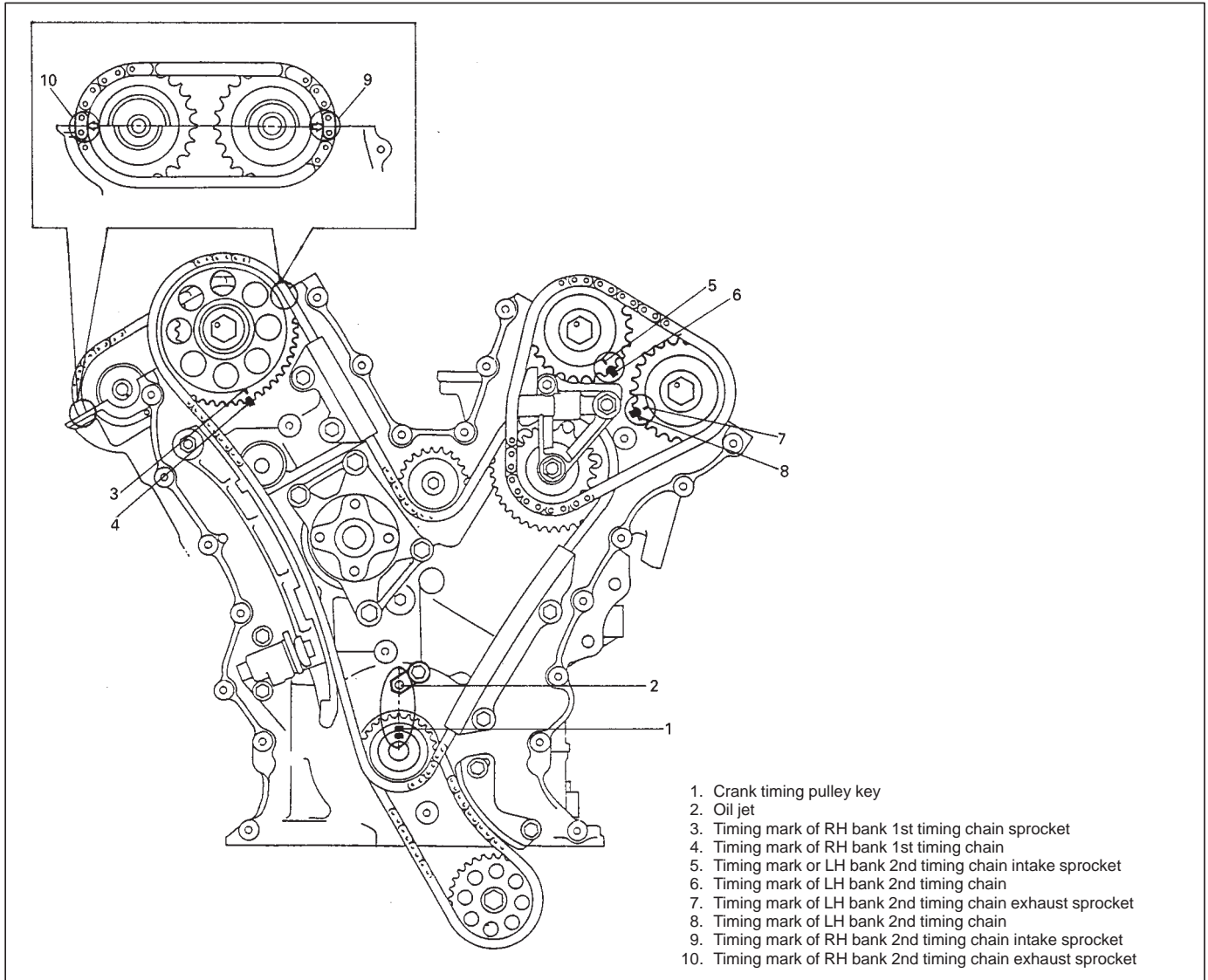

- 12) Apply oil to timing chains, tensioner adjusters sprockets, and guides.  
 13) Install timing chain cover, oil pan, front differential housing, P/S system, cooling system, intake manifold with throttle body and other parts.  
 14) Refill cooling system, P/S system, front differential and engine with each oil/fluid.  
 15) Check wheel alignment, referring to Section 3.  
 16) Verify that there is no fuel leakage, water leakage and oil leakage at each connection.

# 1ST TIMING CHAIN AND CHAIN TENSIONER

1. 1st timing chain
2. Timing chain tensioner adjuster No.1
3. RH bank 1st timing chain intake camshaft sprocket
4. 1st timing chain crankshaft sprocket
5. Idler sprocket No.2
6. Shaft
7. Idler sprocket No.1
8. Shaft
9. Washer
10. Timing chain tensioner
11. Timing chain guide No.1
12. Timing chain guide No.2

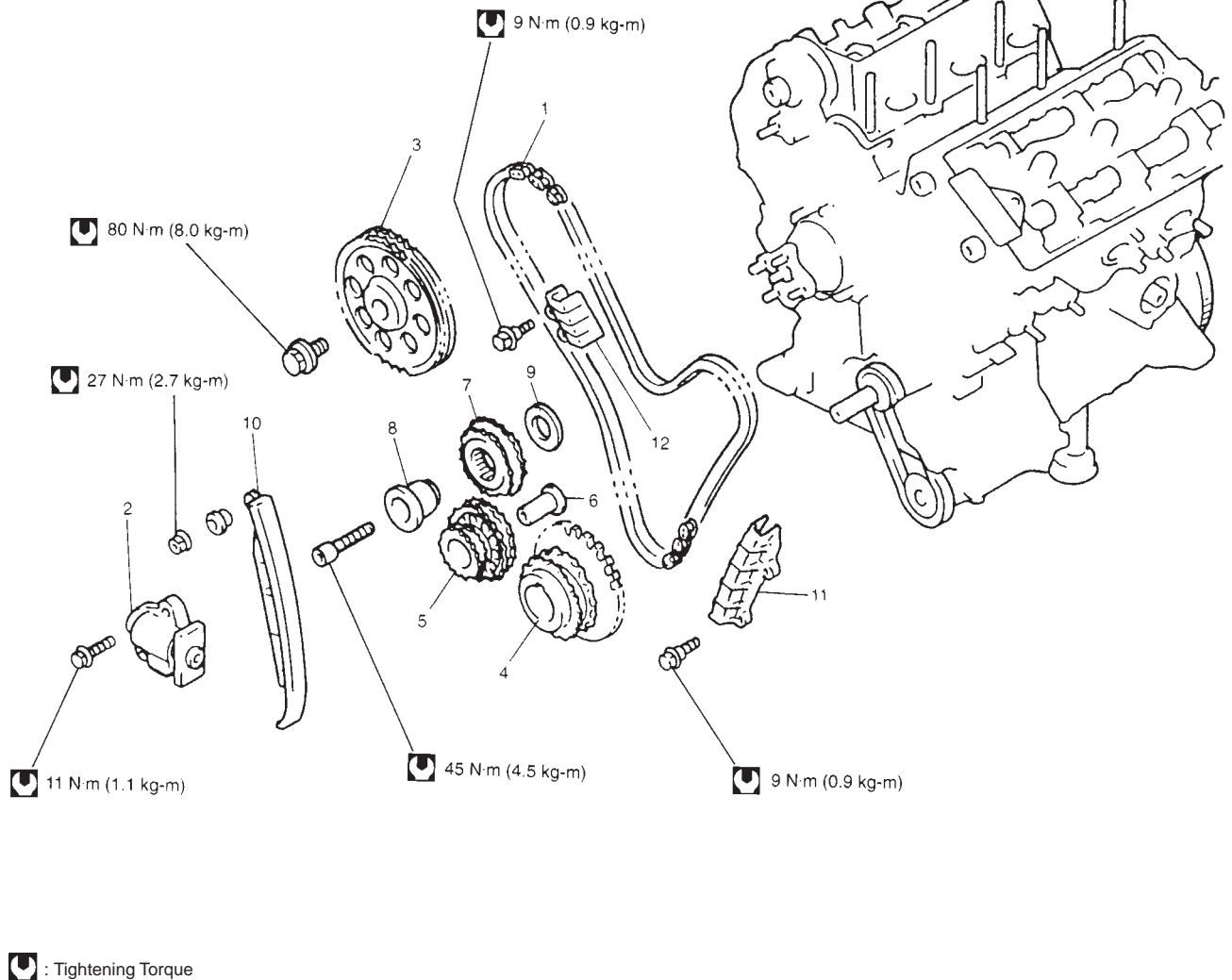

## REMOVAL

- 1) Disconnect negative cable at battery.
- 2) Drain engine oil.
- 3) Drain coolant.
- 4) Remove timing chain cover.

Refer to item "TIMING CHAIN COVER" in this section for removal.

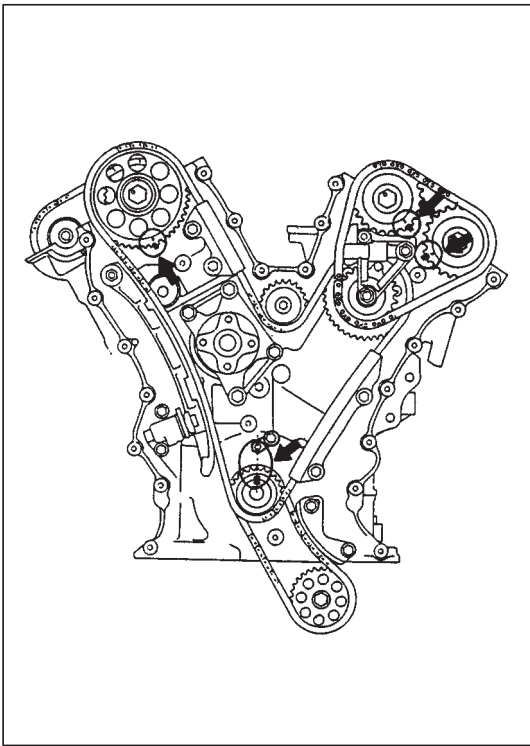

- 5) For reinstallation of timing chain, align 8 timing marks as shown in figure by turning crankshaft.
- 6) Remove LH bank 2nd timing chain.  
Refer to item "LH (NO.1) BANK 2ND TIMING CHAIN AND CHAIN TENSIONER" in this section for removal.

- 7) Remove timing chain guide No.1.
- 8) Remove timing chain guide No.2.
- 9) Remove timing chain tensioner adjuster No.1.
- 10) Remove idler sprocket No.1 and 1st timing chain.
- 11) Remove idler sprocket No.2 and sprocket shaft.
- 12) Remove timing chain tensioner.

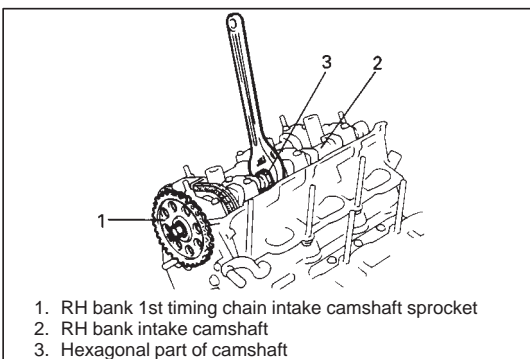

1. RH bank 1st timing chain intake camshaft sprocket
2. RH bank intake camshaft
3. Hexagonal part of camshaft

- 13) Remove RH bank 1st timing chain intake camshaft sprocket bolt. To remove it, fit a spanner to hexagonal part at the center of camshaft to hold it stationary.
- 14) Remove RH bank 1st timing chain intake camshaft sprocket.

- 15) Remove 1st timing chain crankshaft sprocket.

**INSPECTION****Timing chain guides No.1 and No.2**

Check shoe for wear or damage.

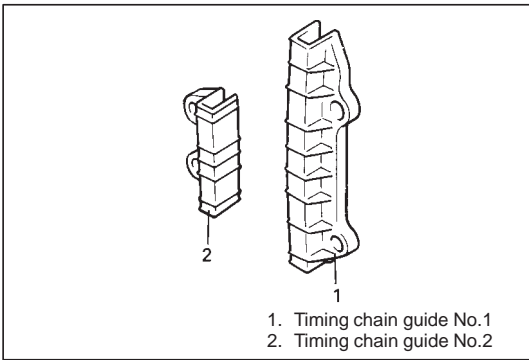
**Timing chain tensioner**

Check shoe for wear or damage.

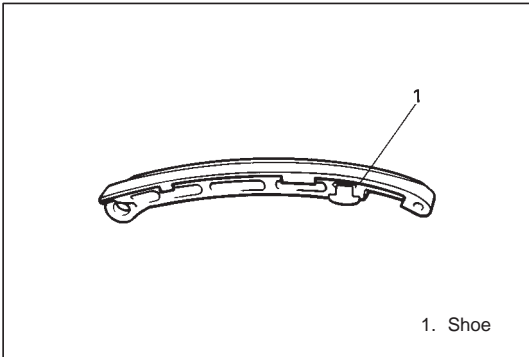
**1st timing chain crankshaft sprocket**

Check teeth of sprocket for wear or damage.

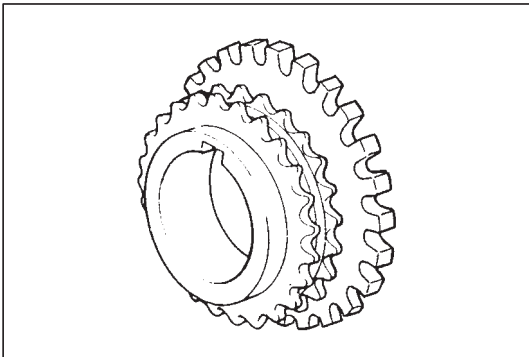
**RH bank 1st timing chain intake camshaft sprocket**

Check teeth of sprocket for wear or damage.

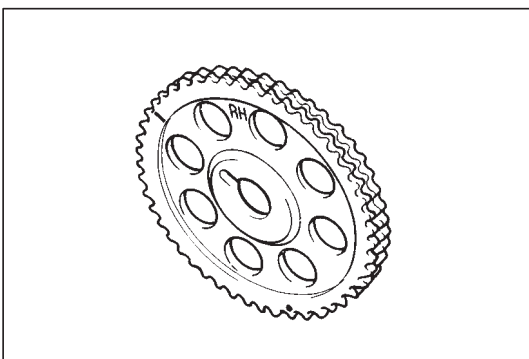
**Idler sprocket No.1**

Check teeth of sprocket for wear or damage.

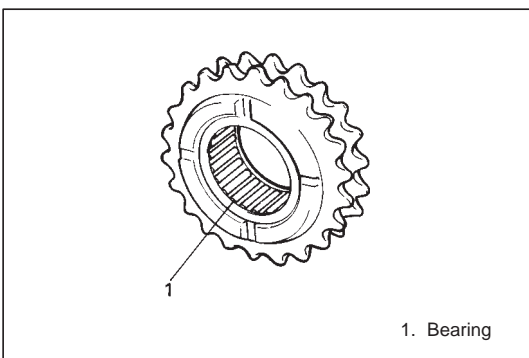

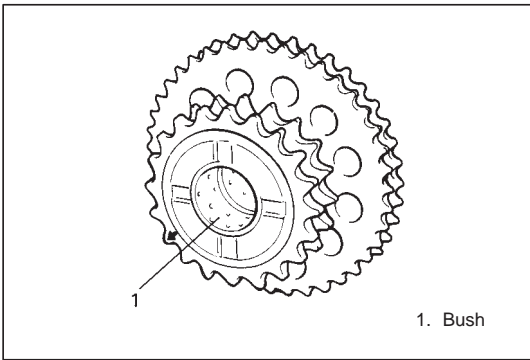

**Idler sprocket No.2**

Check teeth of sprocket for wear or damage.

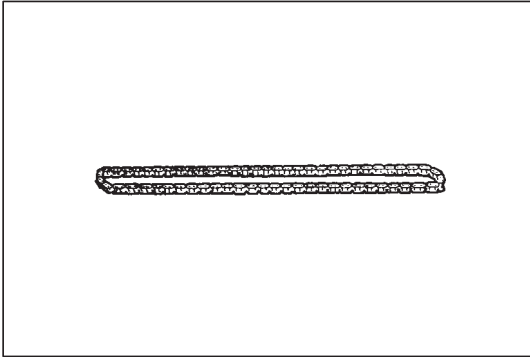

**1st timing chain**

Check timing chain for wear or damage.

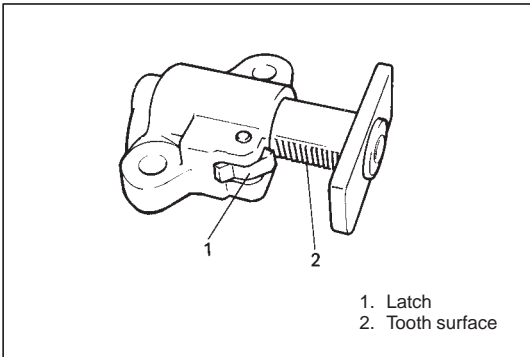

**Timing chain tensioner adjuster No.1**

Check that latch and tooth surface are free from damage and latch functions properly.

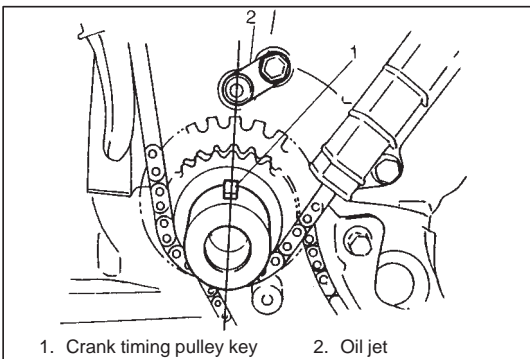

**INSTALLATION**

1) Check timing mark on crankshaft as shown in figure.

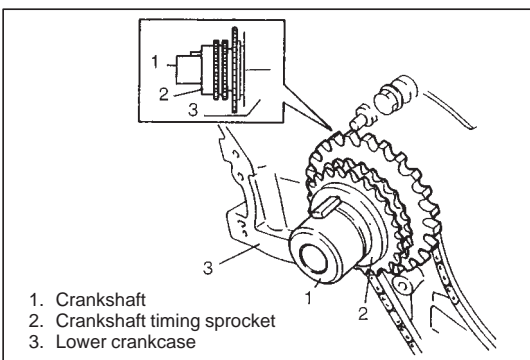

2) Install 1st timing chain crankshaft sprocket as shown in figure. Confirm that tooth for CKP sensor are free from metal particles and damage.

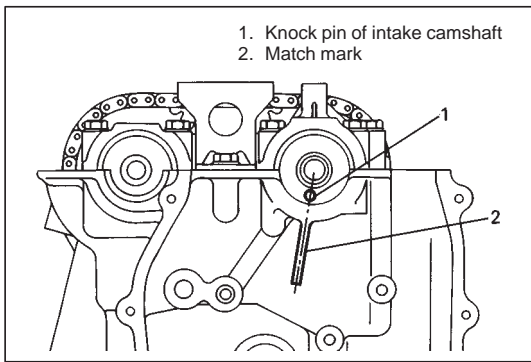

- 3) Check timing mark on RH bank intake camshaft as shown in figure.

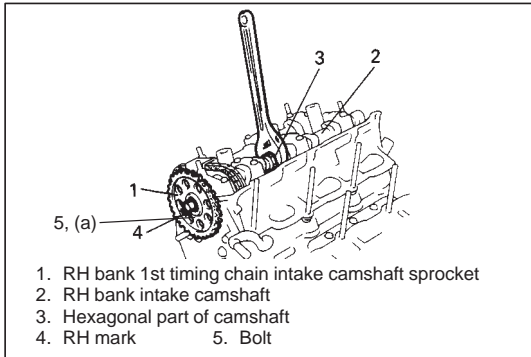

- 4) Install RH bank 1st timing chain intake camshaft sprocket noting following points.
- The sprocket should be set in such way that its RH mark can be seen.
  - Camshaft should be held stationary by using a spanner at its hexagonal parts as shown in figure.

#### Tightening Torque

(a): 80 N·m (8.0 kg-m, 57.5 lb-ft)

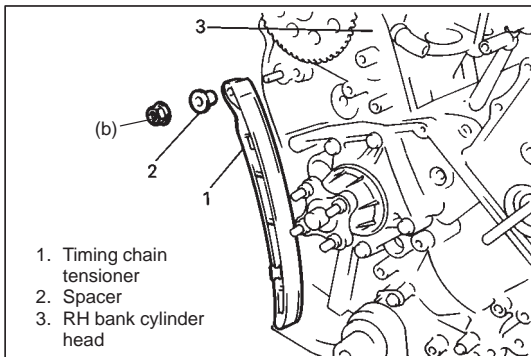

- 5) Install timing chain tensioner as shown in figure.

#### Tightening Torque

(b): 27 N·m (2.7 kg-m, 19.5 lb-ft)

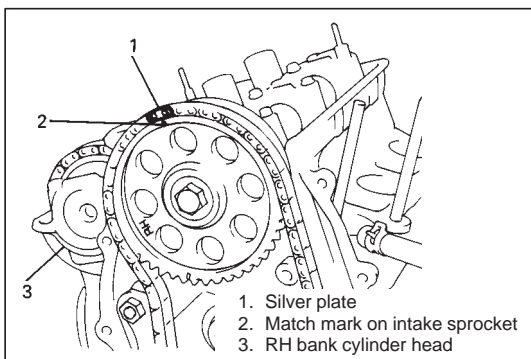

- 6) Install 1st timing chain by aligning match marks on RH silver plate of 1st timing chain and RH bank 1st timing chain intake camshaft sprocket.

- 7) Apply oil to bush of idler sprocket No.2.  
8) Install idler sprocket No.2 and sprocket shaft.

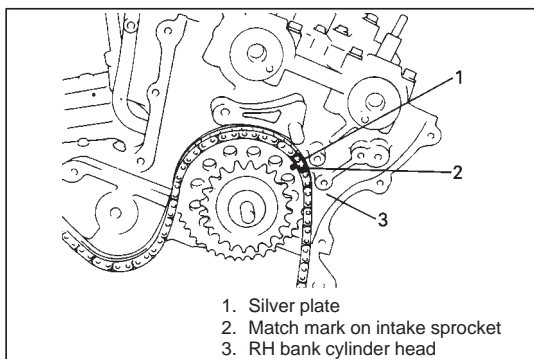

9) Install idler sprocket No.2 by aligning match marks on LH silver plate of 1st timing chain.

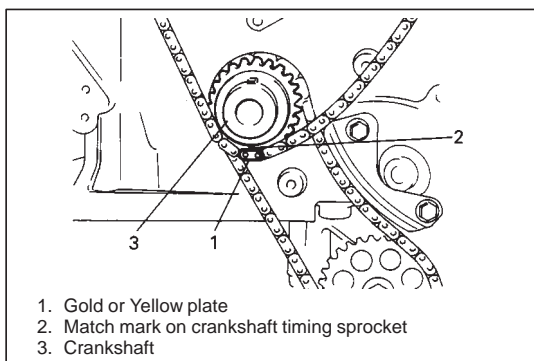

10) Install crankshaft sprocket by aligning match marks on gold or yellow plate of 1st timing chain and crankshaft timing sprocket. To install it, fit a spanner to hexagonal part at the center of RH bank intake camshaft to turn a little.

**CAUTION:**

**Do not turn camshaft more than necessary. If turned excessively, valve and piston may get damaged.**

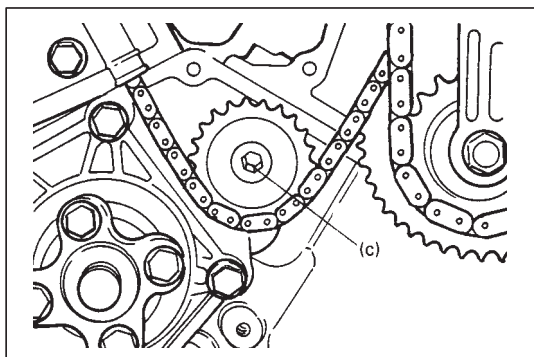

11) Apply oil to bearing of idler sprocket No.1.  
12) Install idler sprocket No.1.

**Tightening Torque**

**(c): 45 N·m (4.5 kg-m, 32.5 lb-ft)**

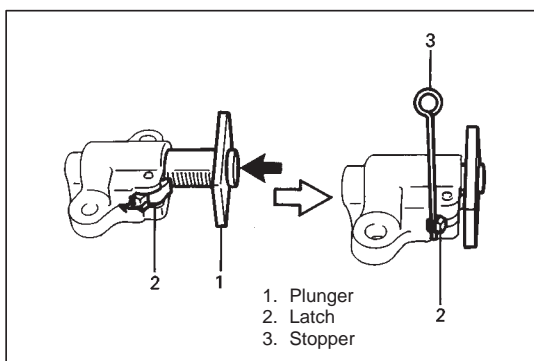

13) With latch of tensioner adjuster No.1 returned and plunger pushed back into body, insert stopper into latch and body. After inserting it, check to make sure that plunger will not come out.

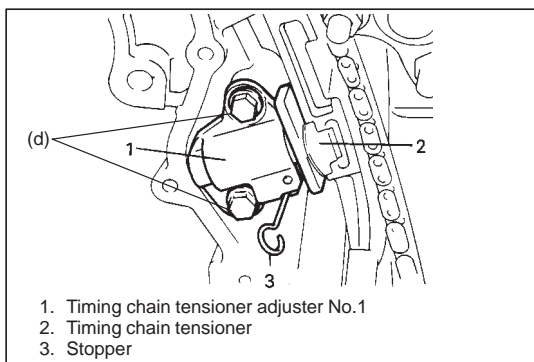

14) Install timing chain tensioner adjuster No.1.

**Tightening Torque**

**(d): 11 N·m (1.1 kg-m, 7.5 lb-ft)**

15) Pull out stopper from adjuster No.1.

16) Install timing chain guide No.1 and No.2.

**Tightening Torque**

**(e): 9 N·m (0.9 kg-m, 6.5 lb-ft)**

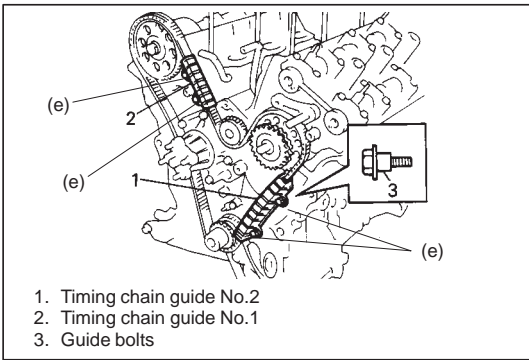

17) Check each aligned timing marks as shown in figure.

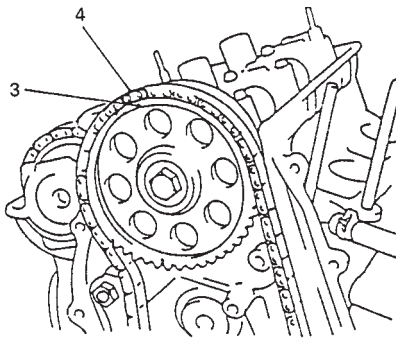

- 3. Match mark of RH bank 1st timing chain sprocket
- 4. Silver plate (LH) of 1st timing chain

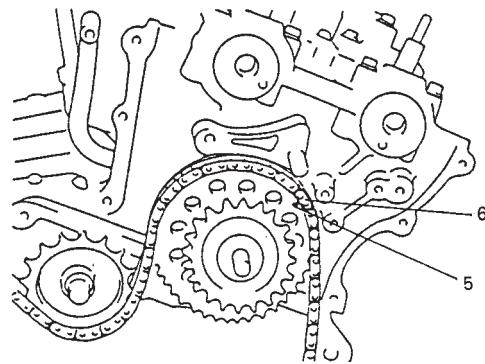

- 5. Match mark of idler sprocket No.2
- 6. Silver plate (RH) of 1st timing chain

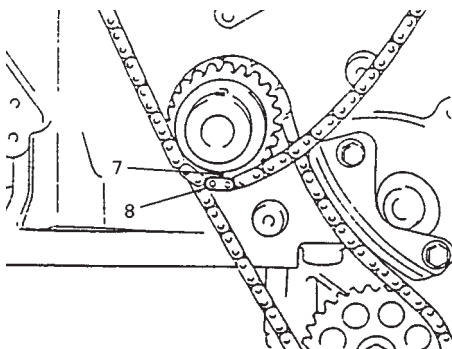

- 7. Match mark of crankshaft timing sprocket
- 8. Gold or Yellow plate of 1st timing chain

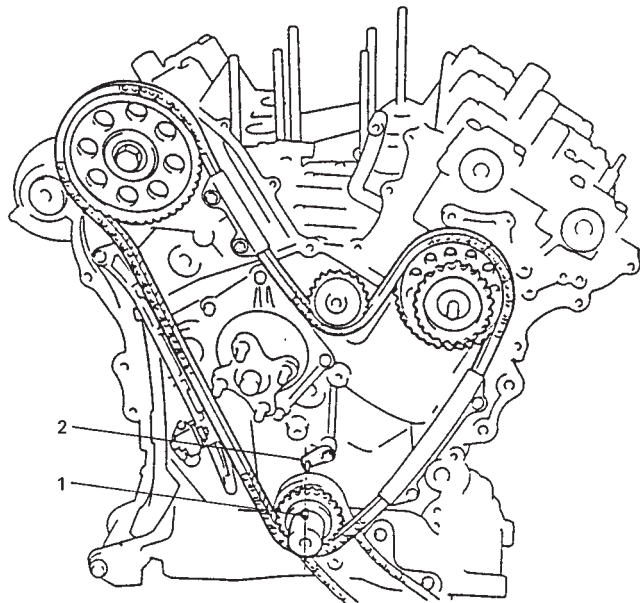

- 1. Crank timing pulley key
- 2. Oil jet

- 18) Install LH bank 2nd timing chain.  
Refer to item "LH (NO.1) BANK 2ND TIMING CHAIN AND TENSIONER" in this section for installation.
  
- 19) Install timing chain cover.  
Refer to item "TIMING CHAIN COVER" in this section for installation.
- 20) Install oil pan, front differential housing, P/S system, cooling system, intake manifold with throttle body and other parts.
- 21) Refill cooling system with coolant, front differential with gear oil, P/S system with specified fluid and engine with engine oil.
- 22) Check wheel alignment referring to Section 3.
- 23) Verify that there is no fuel leakage, water leakage and oil leakage at each connection.

## RH (NO.2) BANK 2ND TIMING CHAIN AND CHAIN TENSIONER

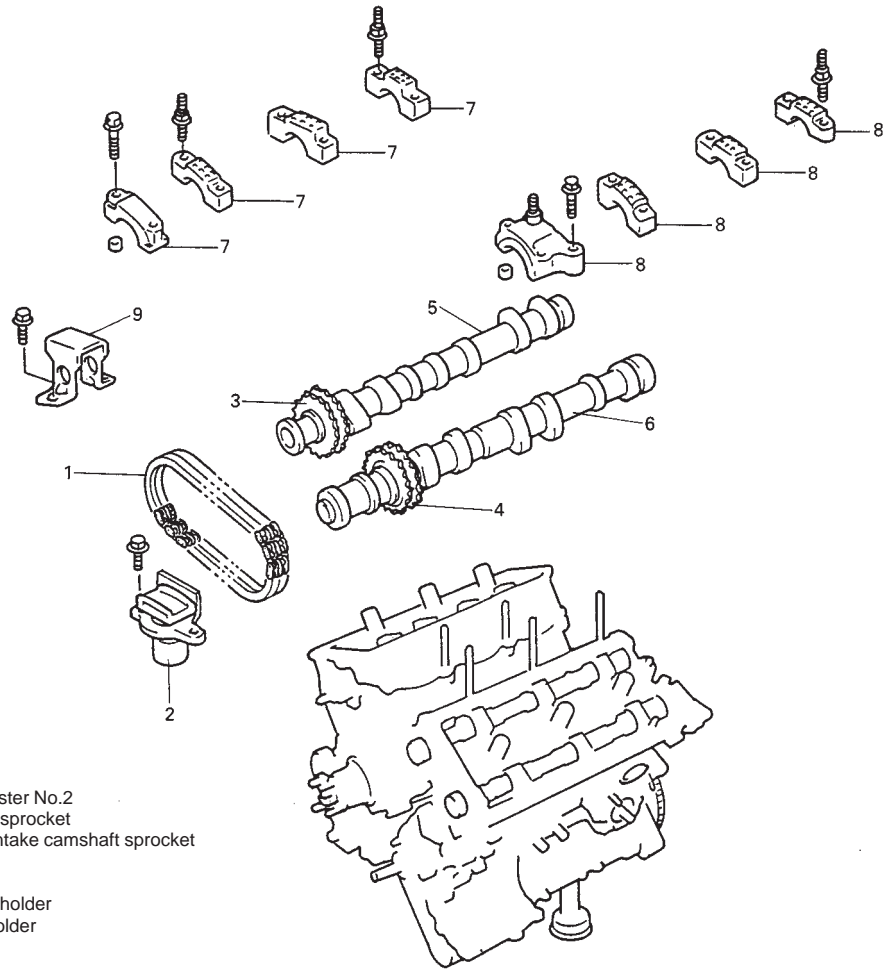

1. RH bank 2nd timing chain
2. Timing chain tensioner adjuster No.2
3. RH bank exhaust camshaft sprocket
4. RH bank 2nd timing chain intake camshaft sprocket
5. RH bank exhaust camshaft
6. RH bank intake camshaft
7. RH bank exhaust camshaft holder
8. RH bank intake camshaft holder
9. Timing chain guide No.3

### REMOVAL

- 1) For reinstallation of timing chain, align 12 timing marks as shown in figure by turning crankshaft.

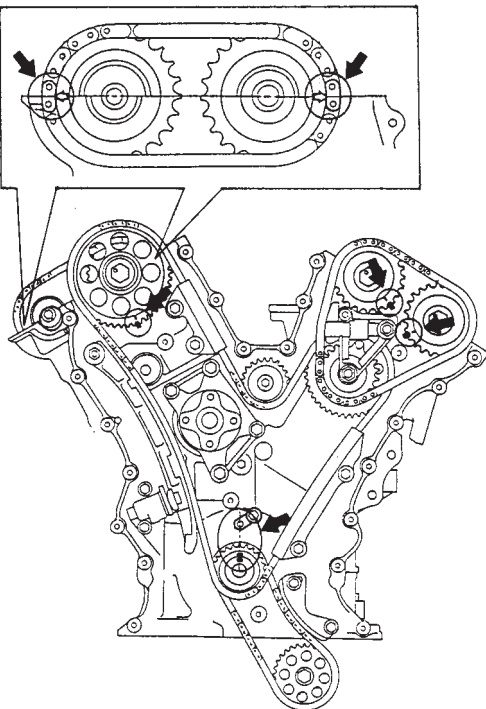

- 2) Remove LH bank 2nd timing chain.  
Refer to item "LH (NO.1) BANK 2ND TIMING CHAIN AND CHAIN TENSIONER" in this section for removal.
- 3) Remove 1st timing chain.  
Refer to item "1ST TIMING CHAIN AND CHAIN TENSIONER" in this section for removal.
- 4) Remove timing chain guide No.3.

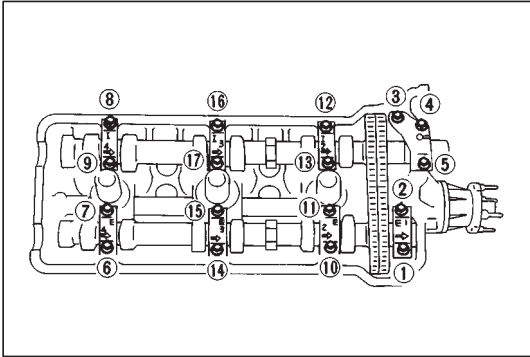

- 5) Loosen camshaft housing bolts in such order as indicated in figure and remove them.
- 6) Remove camshaft housings.

- 7) Remove RH bank intake camshaft, RH bank exhaust camshaft, and RH bank 2nd timing chain as a set.

- 8) Remove timing chain tensioner adjuster No.2.

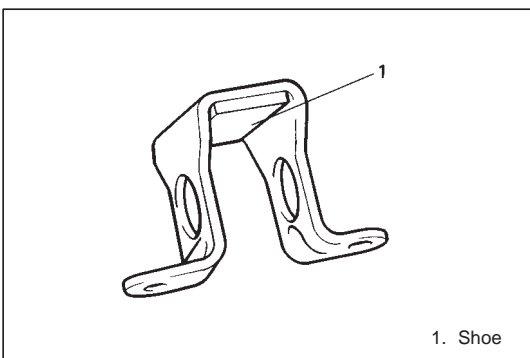

### INSPECTION

#### Timing chain guide No.3

Check shoe for wear or damage.

1. Shoe

**RH bank 2nd timing chain sprockets**

Check teeth of sprocket for wear or damage.

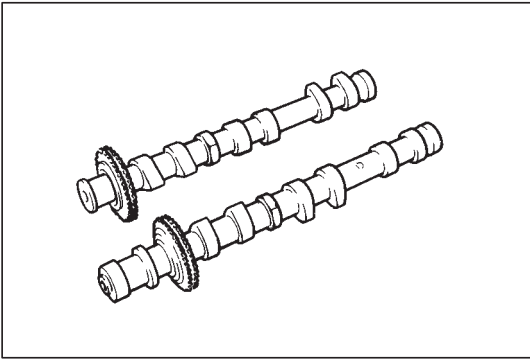
**RH bank 2nd timing chain**

Check timing chain for wear or damage.

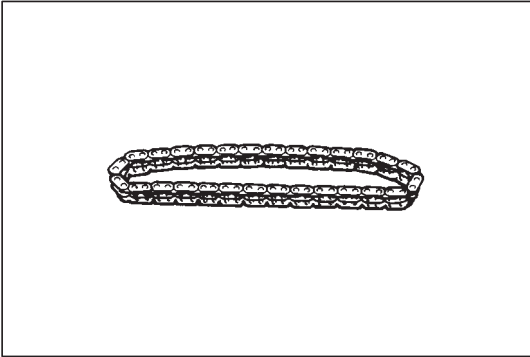
**Timing chain tensioner adjuster No.2**

- Check shoe for wear or damage.
- Check that plunger slides smoothly.

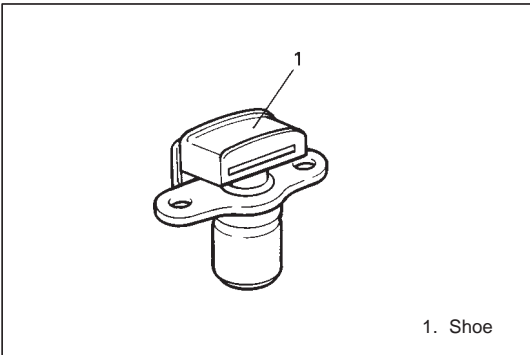

1. Shoe

**INSTALLATION**

1) Check timing mark on crankshaft as shown in figure.

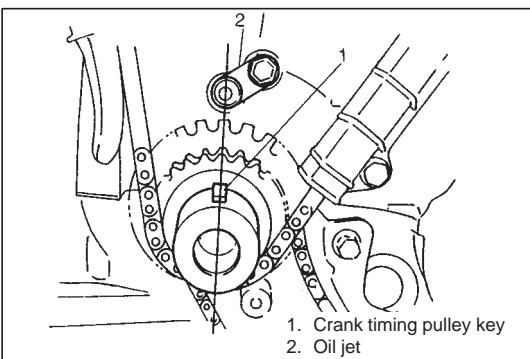

1. Crank timing pulley key  
2. Oil jet

2) Apply oil to timing chain tensioner adjuster No.2.

3) Install timing chain tensioner adjuster No.2.

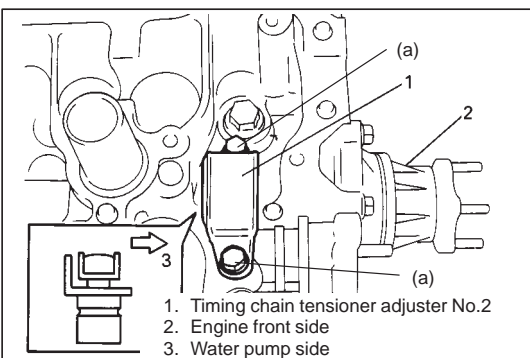

1. Timing chain tensioner adjuster No.2  
2. Engine front side  
3. Water pump side

**Tightening Torque**

(a): 11 N·m (1.1 kg·m, 7.5 lb-ft)

- 4) Apply oil to sliding surface of each camshafts and camshaft journals.

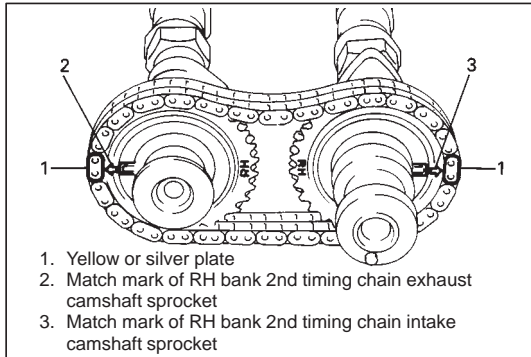

- 5) Install RH bank 2nd timing chain by aligning match marks on yellow or silver plates of RH bank 2nd timing chain, RH bank 2nd timing chain intake camshaft sprocket and RH bank 2nd timing chain exhaust camshaft sprocket as shown in figure.

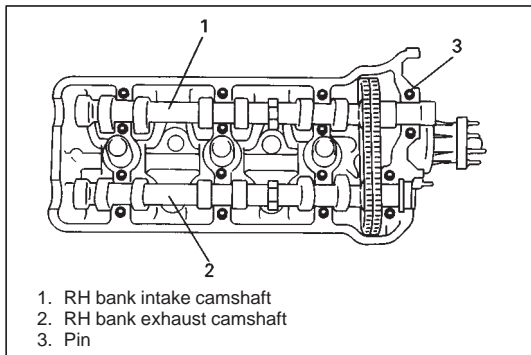

- 6) Install camshaft housing pins as shown in figure.

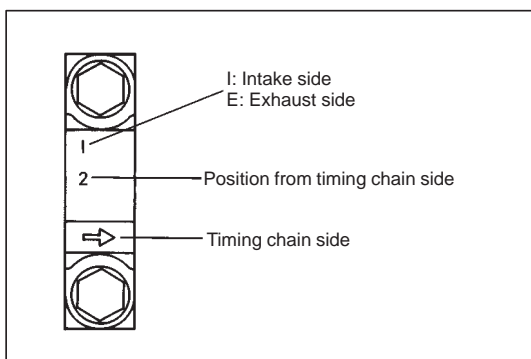

- 7) Check position of camshaft housings. Embossed marks are provided on each camshaft housing, indicating position and direction for installation. Install housings as indicated by these marks.

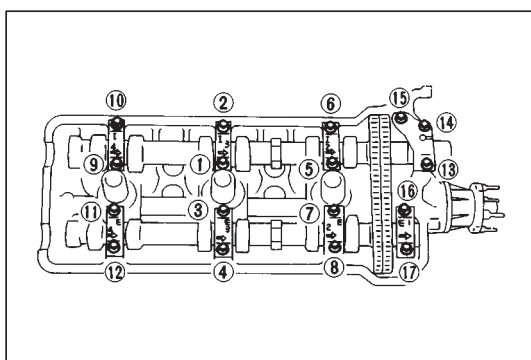

- 8) After applying oil to housing bolts, tighten them temporarily first. Then tighten them by following sequence as indicated in figure. Tighten a little at a time and evenly among bolts and repeat tightening sequence two or three times before they are tightened to specified torque below.

**Tightening Torque**  
**12 N·m (1.2 kg-m, 8.5 lb-ft)**

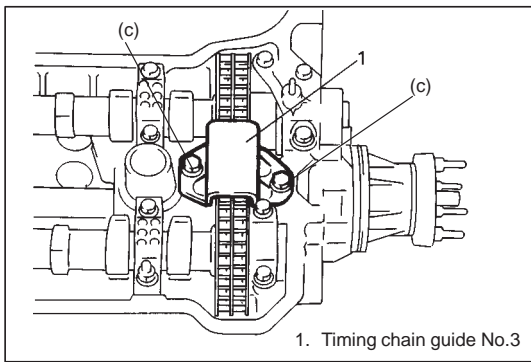

- 9) Install timing chain guide No.3.

### Tightening Torque

(c): 11 N·m (1.1 kg-m, 7.5 lb-ft)

- 10) Install 1st timing chain.  
Refer to item "1ST TIMING CHAIN AND CHAIN TENSIONER" in this section for installation.
- 11) Install LH bank 2nd timing chain.  
Refer to item "LH (NO.1) BANK 2ND TIMING CHAIN AND CHAIN TENSIONER" in this section for installation.
- 12) Install timing chain cover.  
Refer to item "TIMING CHAIN COVER" for installation.
- 13) Install oil pan, front differential housing, P/S system, cooling system, intake manifold with throttle body and other parts.
- 14) Refill cooling system with coolant, front differential with gear oil, P/S system with specified fluid and engine with engine oil.
- 15) Check wheel alignment referring to Section 3.
- 16) Verify that there is no fuel leakage, water leakage and oil leakage at each connection.

## OIL PUMP CHAIN

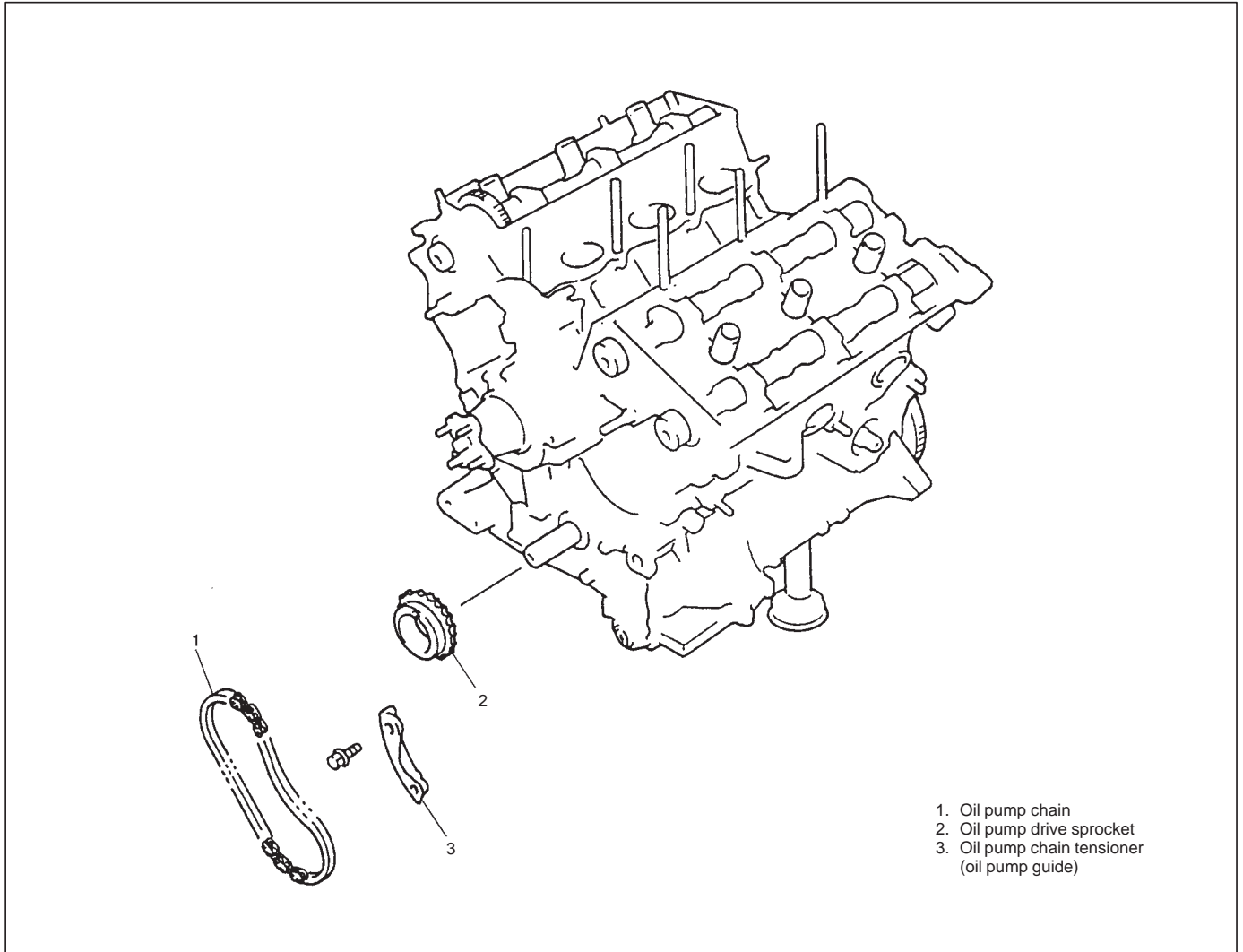

### REMOVAL

- 1) Disconnect negative cable at battery.
- 2) Drain engine oil.
- 3) Drain coolant.
- 4) Remove timing chain cover.  
Refer to item "TIMING CHAIN COVER" in this section for removal.
- 5) Remove LH bank 2nd timing chain.  
Refer to item "LH (NO.1) BANK 2ND TIMING CHAIN AND CHAIN TENSIONER" in this section for removal.
- 6) Remove 1st timing chain.  
Refer to item "1ST TIMING CHAIN AND CHAIN TENSIONER" in this section for removal.

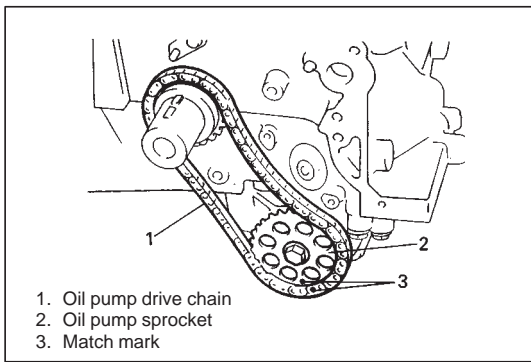

7) Put match marks to oil pump chain and oil pump sprocket.

8) Remove oil pump chain guide.

9) Remove oil pump chain.

10) Remove oil pump drive sprocket.

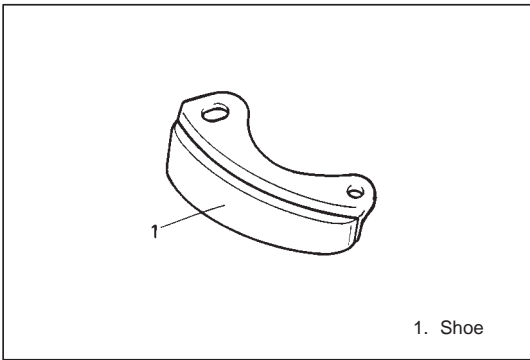

### INSPECTION

#### Oil pump chain guide

Check shoe for wear or damage.

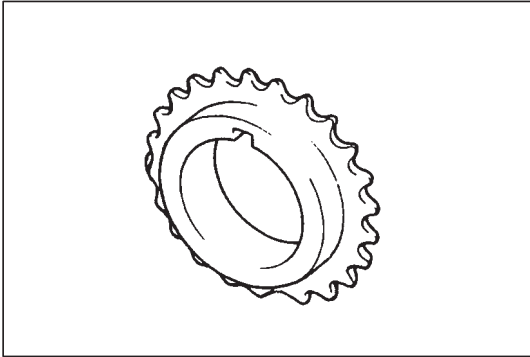

#### Oil pump drive sprocket

Check teeth of sprocket for wear or damage.

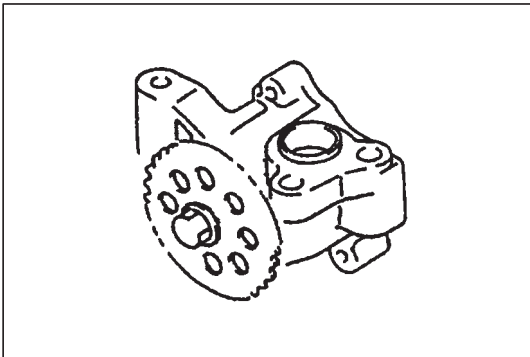

#### Oil pump sprocket

Check teeth of sprocket for wear or damage.

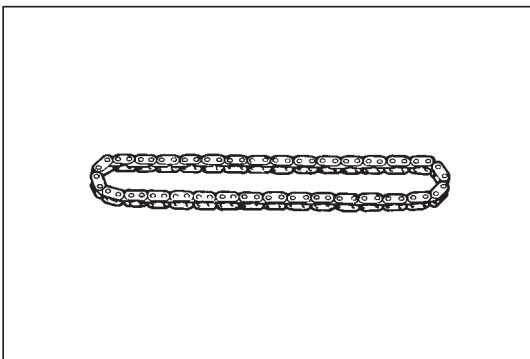

#### Oil pump chain

Check oil pump chain for wear or damage.

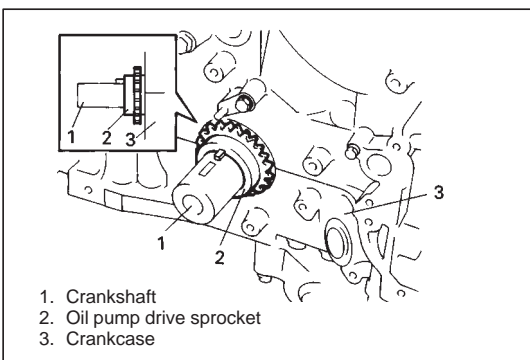

### INSTALLATION

1) Install oil pump drive sprocket as shown in figure.

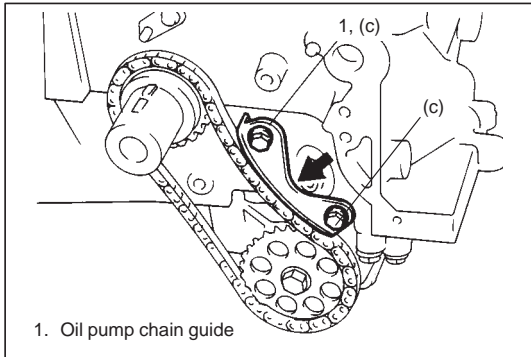
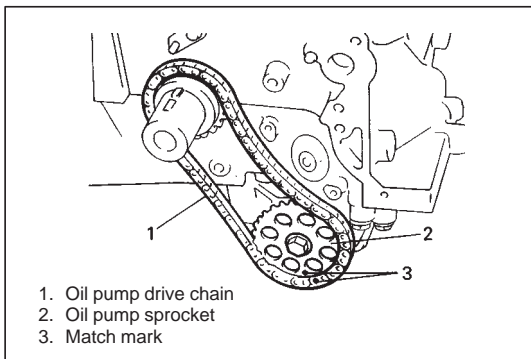

2) Install oil pump chain by aligning match marks on oil pump chain and oil pump sprocket.

3) Install oil pump chain guide and hand-tighten oil pump chain guide bolts.

4) To take up slack of oil pump chain, push center of oil pump chain guide with a force of 0.5 to 0.6 N (50 – 60 g, 0.11 – 0.13 lb) then tighten oil pump chain guide bolts to specified torque.

#### **Tightening Torque**

**(c): 11 N·m (1.1 kg·m, 7.5 lb·ft)**

5) Install 1st timing chain.

Refer to item "1ST TIMING CHAIN AND CHAIN TENSIONER" in this section for installation.

6) Install LH bank 2nd timing chain.

Refer to item "LH (NO.1) BANK 2ND TIMING CHAIN AND CHAIN TENSIONER" in this section for installation.

7) Install timing chain cover.

Refer to item "TIMING CHAIN COVER" in this section for installation.

8) Install oil pan, front differential housing, P/S system, cooling system, intake manifold with throttle body and other parts.

9) Refill cooling system with coolant, front differential with gear oil, P/S system with specified fluid and engine with engine oil.

10) Check wheel alignment referring to Section 3.

11) Verify that there is no fuel leakage, water leakage and oil leakage at each connection.

## CAMSHAFT AND VALVE LASH ADJUSTER

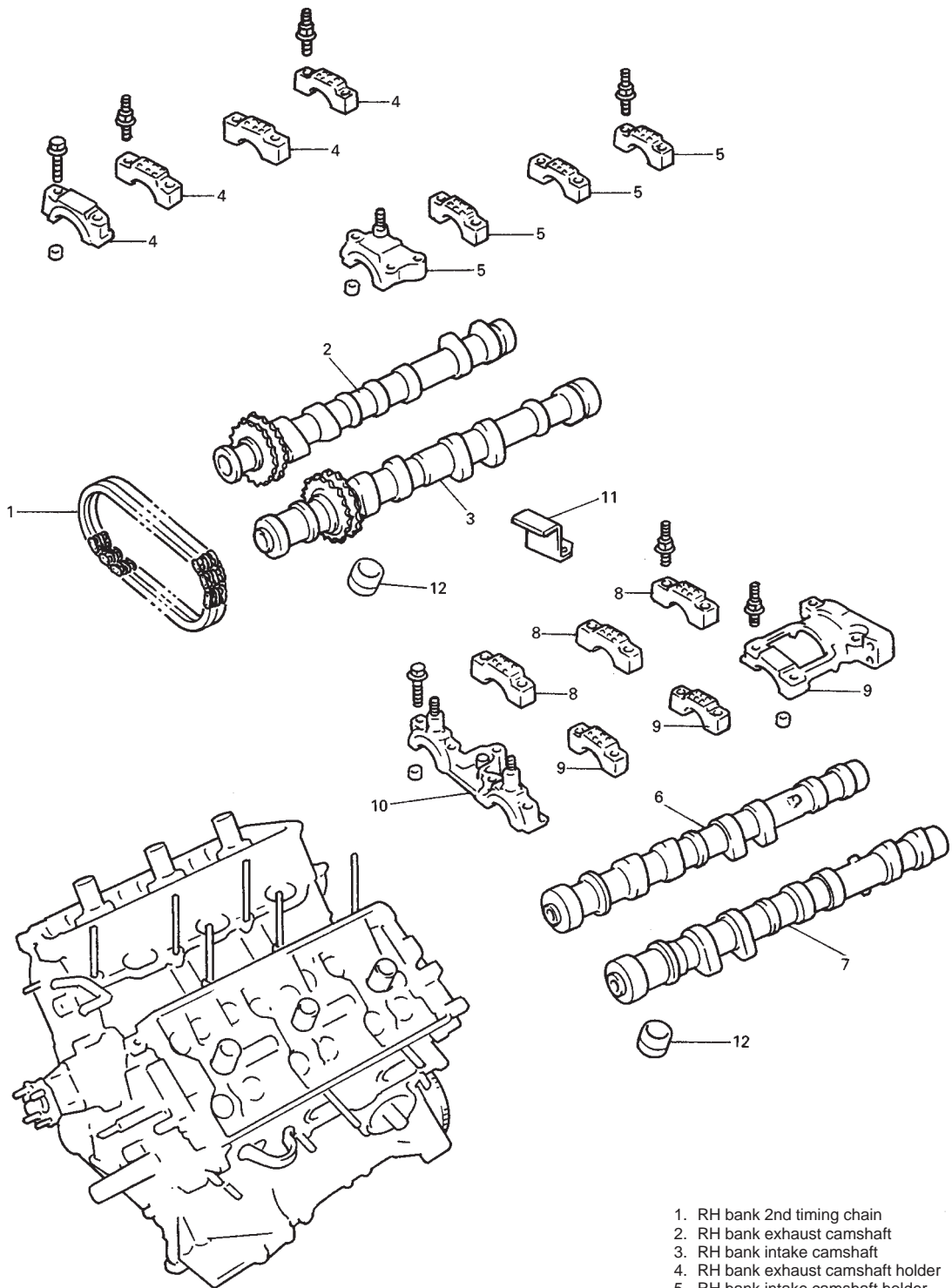

1. RH bank 2nd timing chain
2. RH bank exhaust camshaft
3. RH bank intake camshaft
4. RH bank exhaust camshaft holder
5. RH bank intake camshaft holder
6. LH bank intake camshaft
7. LH bank exhaust camshaft
8. LH bank intake camshaft holder
9. LH bank exhaust camshaft holder
10. LH bank camshaft holder
11. Timing chain guide No.5
12. Valve lash adjuster

**REMOVAL**

- 1) Disconnect negative cable at battery.
- 2) Drain engine oil.
- 3) Drain coolant.
- 4) Remove timing chain cover.  
Refer to item "TIMING CHAIN COVER" in this section for removal.
- 5) Remove LH bank 2nd timing chain.  
Refer to item "LH (NO.1) BANK 2ND TIMING CHAIN AND CHAIN TENSIONER" in this section for removal.
- 6) Remove 1st timing chain.  
Refer to item "1ST TIMING CHAIN AND CHAIN TENSIONER" in this section for removal.
- 7) Remove RH bank camshafts.  
Refer to item "RH (NO.2) BANK 2ND TIMING CHAIN AND CHAIN TENSIONER" in this section for removal.
- 8) Remove CMP sensor. Refer to Section 6F2 for removal.
- 9) Loosen LH bank camshaft housing bolts in such order as indicated in figure and remove them.
- 10) Remove LH bank camshaft housings.
- 11) Remove LH bank camshafts.

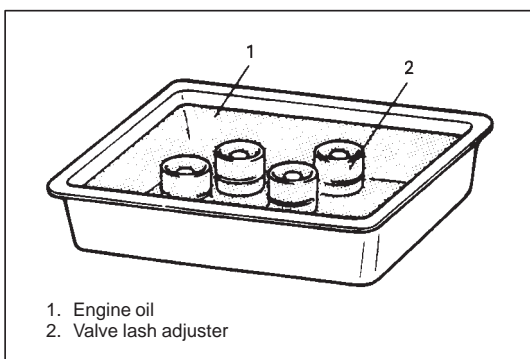
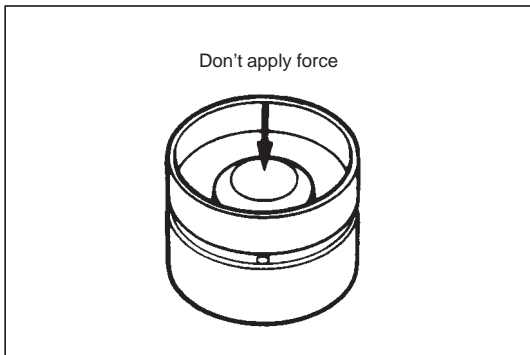
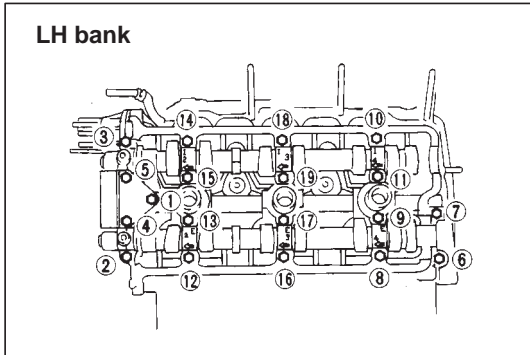

- 12) Remove valve lash adjuster.

**NOTE:**

- **Never disassemble hydraulic valve lash adjuster.**
- **Don't apply force to body of adjuster, oil in high pressure chamber in adjuster will leak.**

- **Immerse removed adjuster in clean engine oil and keep it there till reinstalling it so as to prevent oil leakage. If it is left in air, place it with its bucket body facing down. Don't place on its side or with bucket body facing up.**

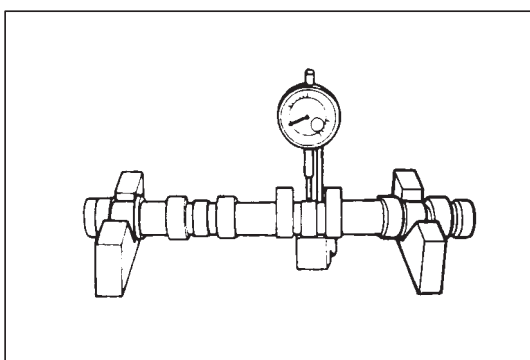
**INSPECTION****Cam Wear**

Using a micrometer, measure cam height. If measured height is below its limit, replace camshaft.

Cam height	Standard	Limit
Intake cam	39.445 – 39.605 mm (1.5530 – 1.5593 in.)	39.400 mm (1.5512 in.)
Exhaust cam	39.428 – 39.588 mm (1.5523 – 1.5586 in.)	39.400 mm (1.5512 in.)

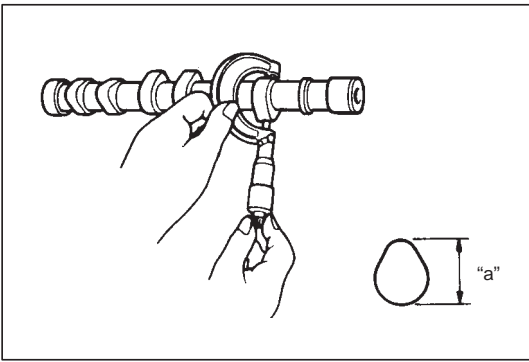

### Camshaft Runout

Set camshaft between two “V” blocks, and measure its runout by using a dial gauge.

If measured runout exceeds below specified limit, replace camshaft.

Runout limit	0.10 mm (0.0039 in.)
--------------	----------------------

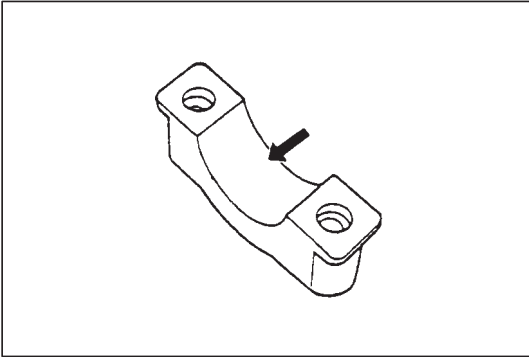

### Camshaft Journal Wear

Check camshaft journals and camshaft housings for pitting, scratches, wear or damage.

If any malcondition is found, replace camshaft or cylinder head with housing. Never replace cylinder head without replacing housings.

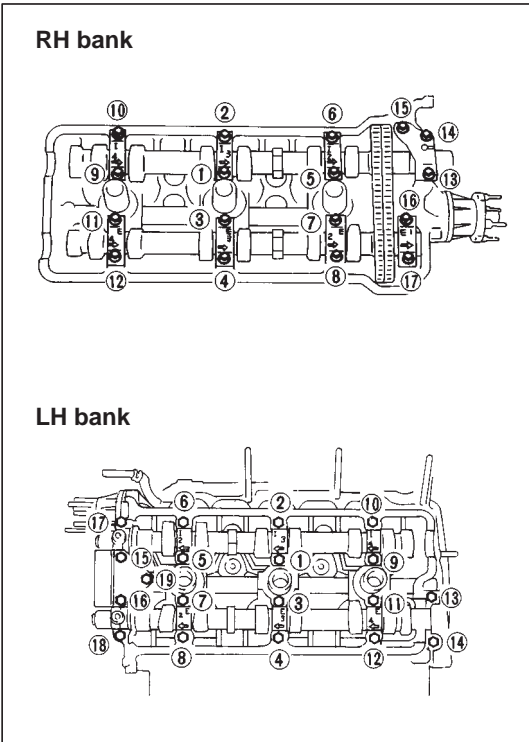

Check clearance by using gaging plastic. The procedure is as follows.

- 1) Clean housings and camshaft journals.
- 2) Make sure that all valve lash adjusters are removed and install camshaft to cylinder head.
- 3) Place a piece of gaging plastic the full width of journal of camshaft (parallel to camshaft).
- 4) Install camshaft housing.
- 5) Tighten camshaft housing bolts in such order as indicated in figure a little at a time till they are tightened to specified torque.

**NOTE:**

**Do not rotate camshaft while gaging plastic is installed.**

- 6) Remove housing, and using scale on gaging plastic envelop, measure gaging plastic width at its widest point.

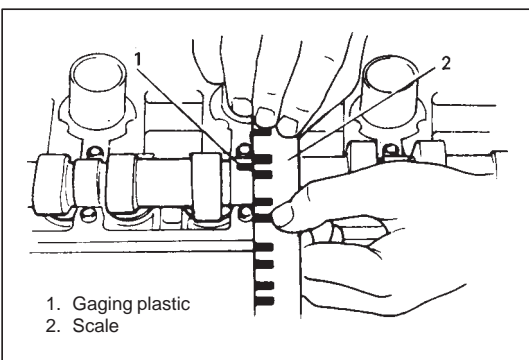

1. Gaging plastic  
2. Scale

	Standard	Limit
Journal clearance	0.045 – 0.099 mm (0.0018 – 0.0039 in.)	0.12 mm (0.0047 in.)

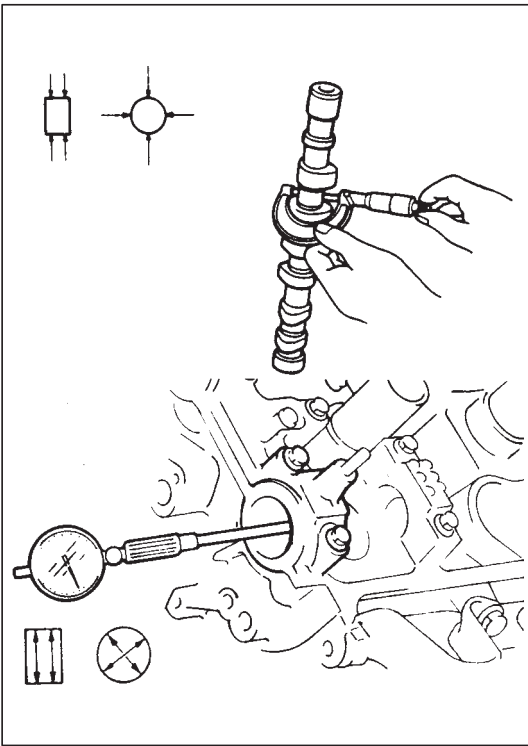

If measured camshaft journal clearance exceeds limit, measure journal (housing) bore and outside diameter of camshaft journal. Replace camshaft or cylinder head assembly whichever the difference from specification is greater.

	Standard
Camshaft journal bore dia. (IN & EX)	26.000 – 26.033 mm (1.0236 – 1.0249 in.)
Camshaft journal O.D. (IN & EX)	25.934 – 25.955 mm (1.0210 – 1.0218 in.)

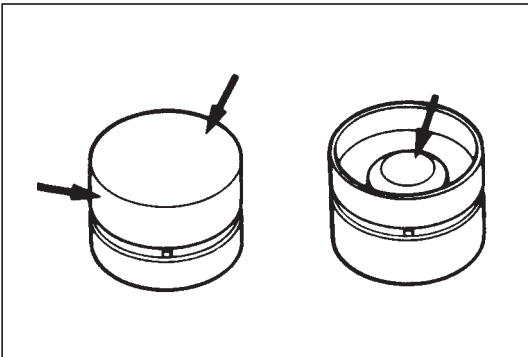

#### Wear of Hydraulic Valve Lash Adjuster

Check adjuster for pitting, scratches, or damage. If any malcondition is found, replace.

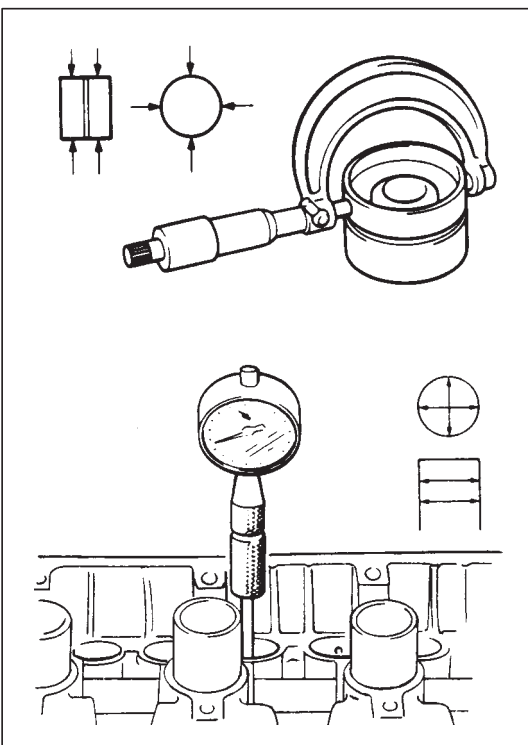

Measure cylinder head bore and adjuster outside diameter to determine cylinder head-to-adjuster clearance. If clearance exceeds limit, replace adjuster or cylinder head.

Item	Standard	Limit
Hydraulic valve lash adjuster O.D.	30.959 – 30.975 mm (1.2188 – 1.2194 in.)	–
Cylinder head bore	31.000 – 31.025 mm (1.2205 – 1.2214 in.)	–
Cylinder head to adjuster clearance	0.025 – 0.066 mm (0.0010 – 0.0025 in.)	0.15 mm (0.0059 in.)

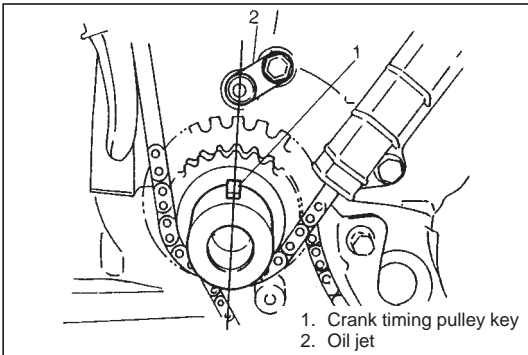
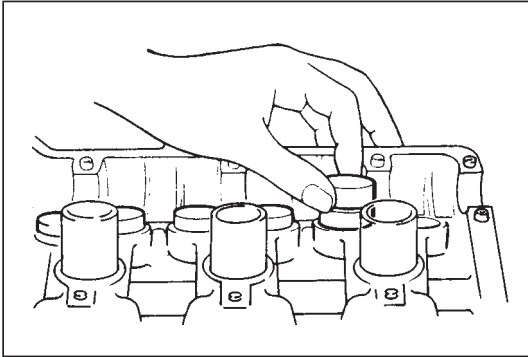
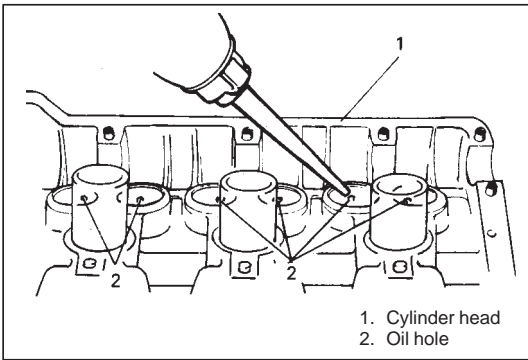

## INSTALLATION

- 1) Before installing valve lash adjuster to cylinder head, fill oil passage of cylinder head with engine oil according to following procedure.

Pour engine oil through oil holes and check that oil comes out from oil holes in sliding part of valve lash adjuster. Perform this check on both intake and exhaust sides.

- 2) Valve lash adjuster to cylinder head.

Apply engine oil around valve lash adjuster and then install it to cylinder head.

- 3) Check timing mark on crankshaft as shown in figure.

- 4) Install RH bank camshafts, referring to item "RH (NO.2) BANK 2ND TIMING CHAIN AND CHAIN TENSIONER" in this section for installation.

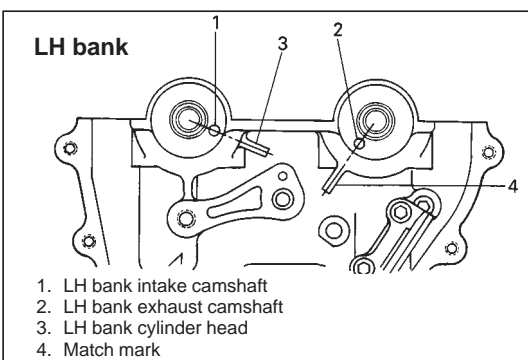

- 5) Install LH bank camshafts.

Apply oil to sliding surface of each camshaft and camshaft journal then install them by aligning match marks on cylinder head and LH bank camshafts as shown in figure.

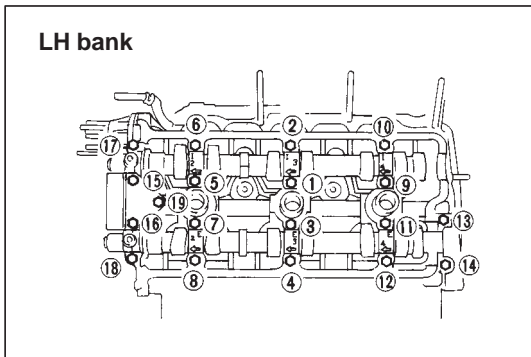
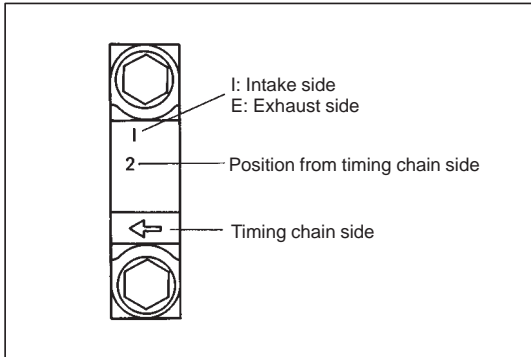
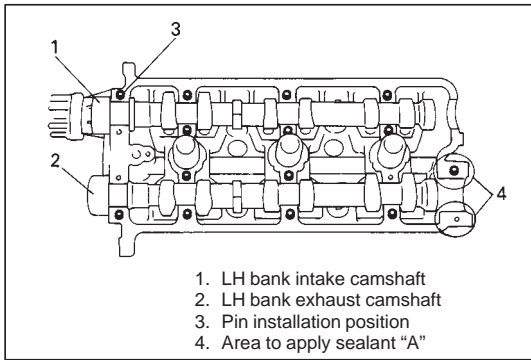

- 6) Install LH bank camshaft housing pins as shown in figure.  
 7) Apply sealant "A" to LH bank exhaust camshaft housing No.5 sealing surface area as shown in figure.

**"A": Sealant 99000-31150**

- 8) Check position of LH bank camshaft housings.  
 Embossed marks are provided on each camshaft housing, indicating position and direction for installation. Install housings as indicated by these marks.

- 9) After applying oil to housing bolts, tighten them temporarily first. Then tighten them by following sequence as indicated in figure. Tighten a little at a time and evenly among bolts and repeat tightening sequence two or three times before they are tightened to specified torque below.

**Tightening Torque**  
**12 N·m (1.2 kg-m, 8.5 lb-ft)**

- 10) Install 1st timing chain.  
Refer to item "1ST TIMING CHAIN AND CHAIN TENSIONER" in this section for installation.
- 11) Install LH bank 2nd timing chain.  
Refer to item "LH (NO.1) BANK 2ND TIMING CHAIN AND CHAIN TENSIONER" in this section for installation.
- 12) Install timing chain cover.  
Refer to item "TIMING CHAIN COVER" in this section for installation.
- 13) Install oil pan, front differential housing, P/S system, cooling system, intake manifold with throttle body and other parts.
- 14) Install CMP sensor. Refer to Section 6F2 for details.
- 15) Refill cooling system with coolant, front differential with gear oil, P/S system with specified fluid and engine with engine oil.
- 16) Check wheel alignment referring to Section 3.
- 17) Verify that there is no fuel leakage, water leakage and oil leakage at each connection.
- 18) Check ignition timing, referring to Section 6F2.

**CAUTION:**

- **Don't turn camshafts or start engine (i.e., valves should not be operated) for about half an hour after re-installing hydraulic valve lash adjusters and camshafts. As it takes time for valves to settle in place, operating engine within half an hour after their installation may cause interference to occur between valves themselves or valves and piston.**
- **If air is trapped in valve lash adjuster, valve may make tapping sound when engine is operated after valve lash adjuster is installed. In such a case, run engine for about half an hour at about 2,000 – 3,000 r/min., and then air will be purged and tapping sound will cease. Should tapping sound not cease, it is possible that valve lash adjuster is defective. Replace it if defective.**

**If defective adjuster can't be located by hearing among 24 of them, check as follows.**

- 1) Stop engine and remove cylinder head cover.**
- 2) Push adjuster downward by hand (with less than 20 kg or 44 lbs force) when cam crest is not on adjuster to be checked and check if clearance exists between cam and adjuster. If it does, adjuster is defective and needs replacement.**

## VALVE LASH ADJUSTER NOISE DIAGNOSIS

In case of the followings, valve lash adjuster noise may be caused by air trapped into valve lash adjusters.

- Vehicle is left for 24 hours or more.
- Engine oil is changed.
- Hydraulic lash adjuster is replaced or reinstalled.
- Engine is overhauled.

If noise from valve lash adjusters is suspected, perform the following checks.

1) Check engine oil for the followings.

- Oil level in oil pan  
If oil level is low, add oil up to Full level hole on oil level gauge.
- Oil quality  
If oil is discolored, or deteriorated, change it.  
For particular oil to be used, refer to Section 0B.
- Oil leaks  
If leak is found, repair it.
- Oil pressure (refer to Oil Pressure Check in this section)  
If defective pressure is found, repair it.

2) Run engine for about half an hour at about 2,000 to 3,000 r/min., and then air will be purge and tapping sound will cease.

3) Should tapping sound not cease, it is possible that hydraulic valve lash adjuster is defective.

Replace it if defective.

If defective adjuster can't be located by hearing among 24 of them, check as follows.

- i) Stop engine and remove cylinder head cover.
- ii) Push adjuster downward by hand (with less than 20 kg or 44 lbs. Force) when cam crest is not on adjuster to be check if clearance exists between cam and adjuster.  
If it does, adjuster is defective and needs replacement.

## VALVES AND CYLINDER HEADS

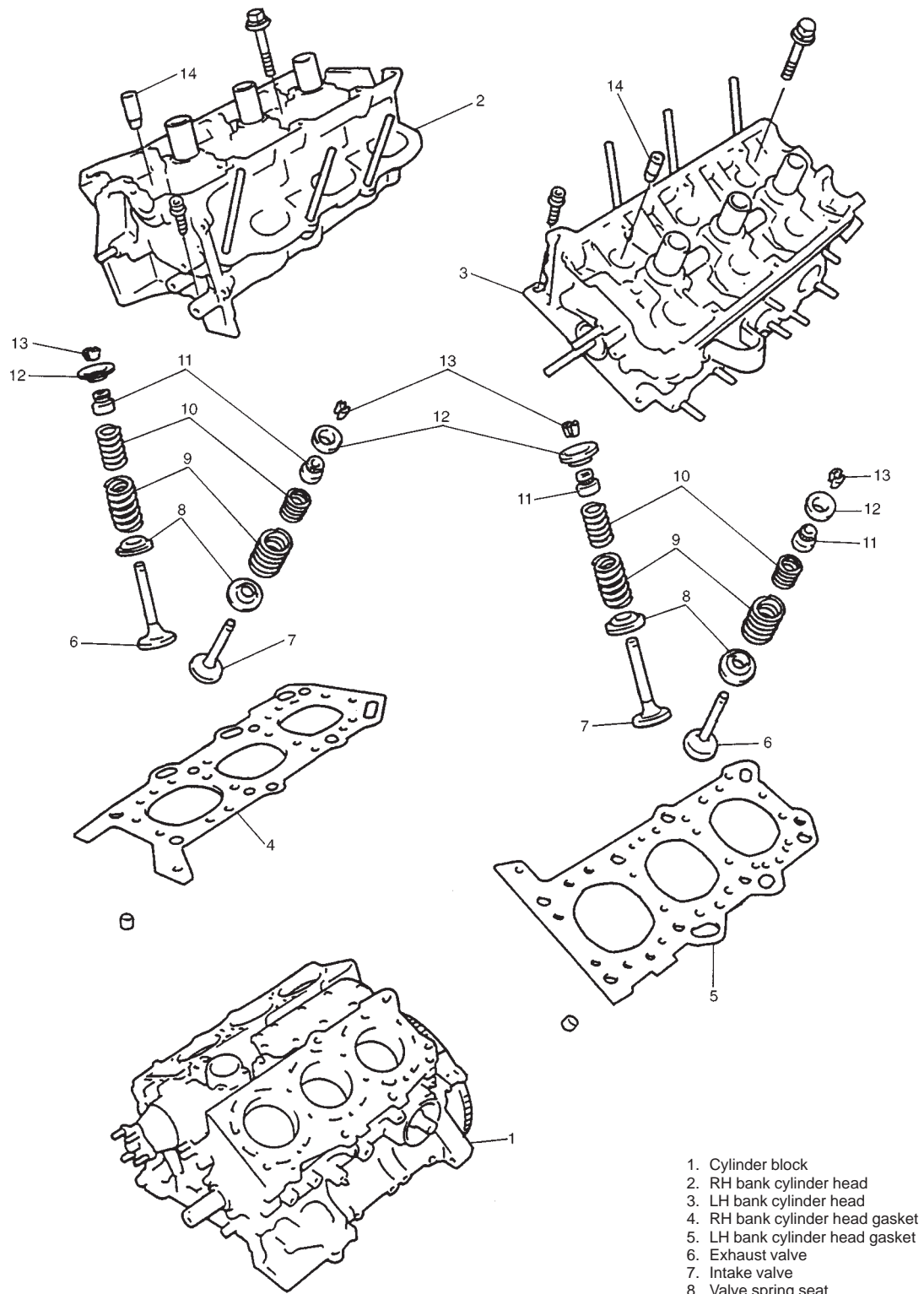

1. Cylinder block
2. RH bank cylinder head
3. LH bank cylinder head
4. RH bank cylinder head gasket
5. LH bank cylinder head gasket
6. Exhaust valve
7. Intake valve
8. Valve spring seat
9. Outer valve spring
10. Inner valve spring
11. Valve stem oil seal
12. Valve spring retainer
13. Valve cotter
14. Valve guide

**REMOVAL**

- 1) Relieve fuel pressure according to procedure described in Section 6.
- 2) Disconnect negative cable at battery.
- 3) Drain engine oil.
- 4) Drain coolant.
- 5) Remove CMP sensor, camshaft and valve lash adjuster.  
Refer to Section 6F2 for CMP sensor removal and item "CAM-SHAFT AND VALVE LASH ADJUSTER" in this section for camshaft and valve lash adjuster removal.
- 6) Remove exhaust manifold.  
Refer to item "EXHAUST MANIFOLD" in this section for removal.
- 7) Remove water outlet cap.

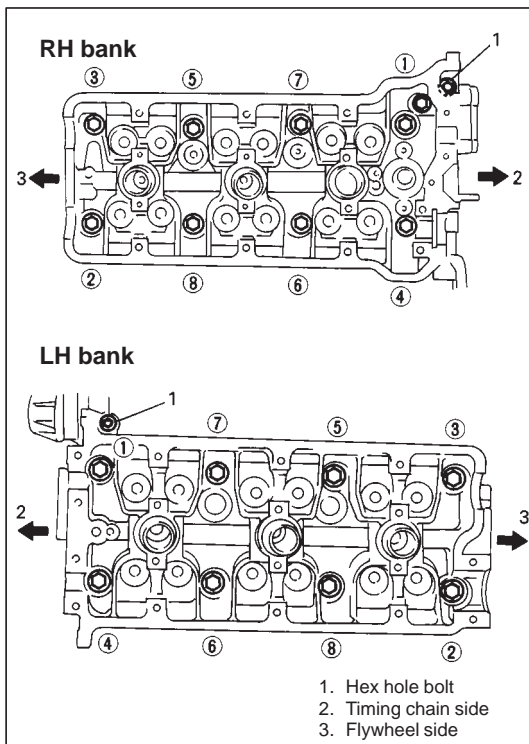

- 8) Loosen cylinder head bolts in such order as indicated in figure and remove them.

**NOTE:**

**Don't forget to remove two hex bolts shown in figure.**

- 9) Remove cylinder heads.

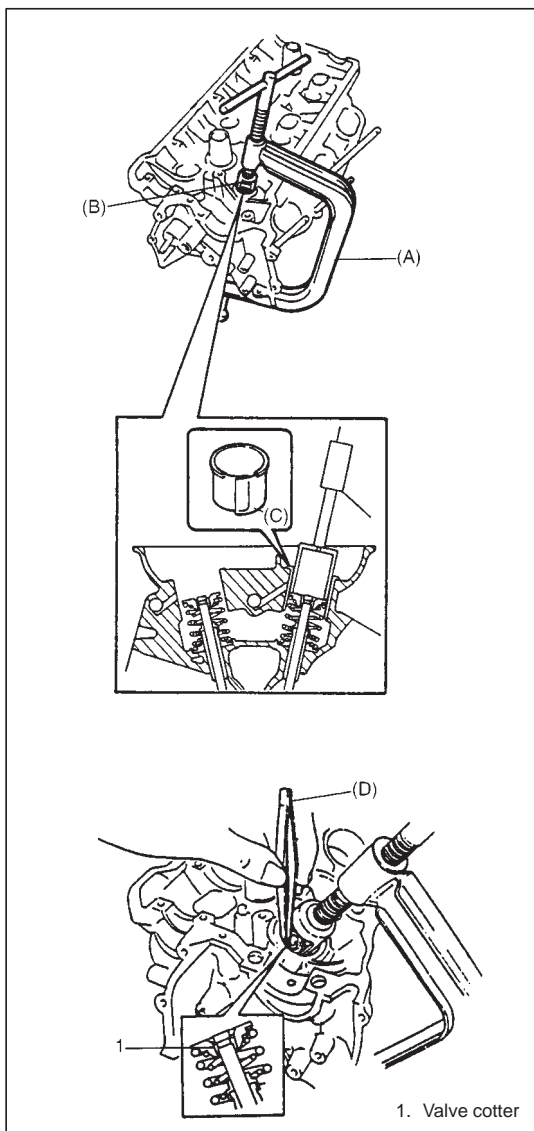

## DISASSEMBLY

- 1) Using special tools (A), (B) & (C), compress valve springs and then remove valve cottes by using special tool (D).

### Special Tool

(A): 09916-14510

(B): 09916-14910

(C): 09919-28610

(D): 09916-84511

- 2) Release special tool, and remove spring retainer and valve spring.
- 3) Remove valve from combustion chamber side.

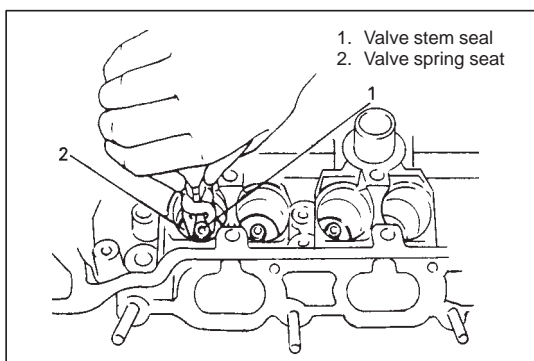

- 4) Remove valve stem seal from valve guide, and then valve spring seat.

### NOTE:

**Do not reuse seal once disassembled. Be sure to use new seal when assembling.**

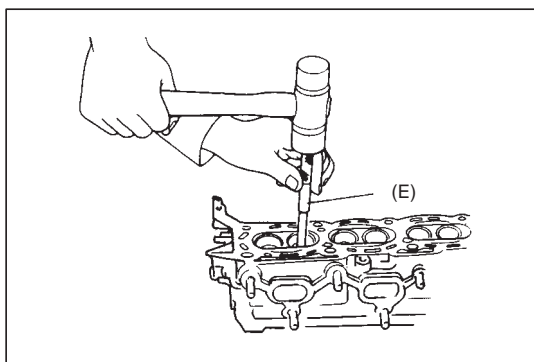

- 5) Using special tool (E) (Valve guide remover), drive valve guide out from combustion chamber side to valve spring side.

### Special Tool

(E): 09916-44910

### NOTE:

**Do not reuse valve guide once disassembled. Be sure to use new valve guide (Oversize) when assembling.**

- 6) Place disassembled parts except valve stem seal and valve guide in order so that they can be installed in their original positions.

## INSPECTION

### Valve Guides

Using a micrometer and bore gauge, take diameter readings on valve stems and guides to check stem-to-guide clearance. Be sure to take reading at more than one place along the length of each stem and guide.

If clearance exceeds limit, replace valve and valve guide.

Item		Standard	Limit
Valve stem diameter	Intake	5.965 – 5.980 mm (0.2348 – 0.2354 in.)	–
	Exhaust	5.940 – 5.955 mm (0.2339 – 0.2344 in.)	–
Valve guide I.D.	In & Ex	6.000 – 6.012 mm (0.2362 – 0.2367 in.)	–
Stem-to-guide clearance	Intake	0.020 – 0.047 mm (0.0008 – 0.0018 in.)	0.07 mm (0.0027 in.)
	Exhaust	0.045 – 0.072 mm (0.0018 – 0.0028 in.)	0.09 mm (0.0035 in.)

### Valves

- Remove all carbon from valves.
- Inspect each valve for wear, burn or distortion at its face and stem and, as necessary, replace it.
- Measure thickness of valve head. If measured thickness exceeds limit, replace valve.

Item	Standard	Limit
Intake	1.0 mm (0.039 in.)	0.6 mm (0.023 in.)
Exhaust	1.2 mm (0.047 in.)	0.7 mm (0.027 in.)

- Inspect valve stem end face for pitting and wear. If pitting or wear is found there, valve stem end may be resurfaced, but not too much to grind off its chamfer. When it is worn out too much that its chamfer is gone, replace valve.

- Check each valve for radial runout with a dial gauge and “V” block. To check runout, rotate valve slowly. If runout exceeds its limit, replace valve.

**Limit on valve head radial runout:**

**0.08 mm (0.003 in.)**

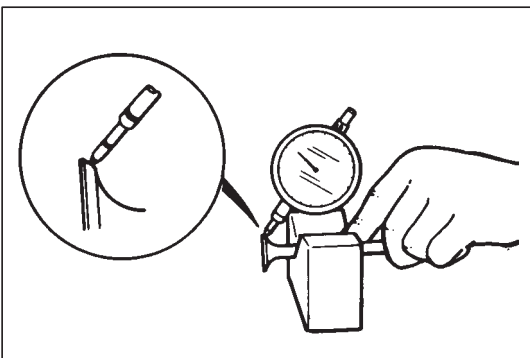
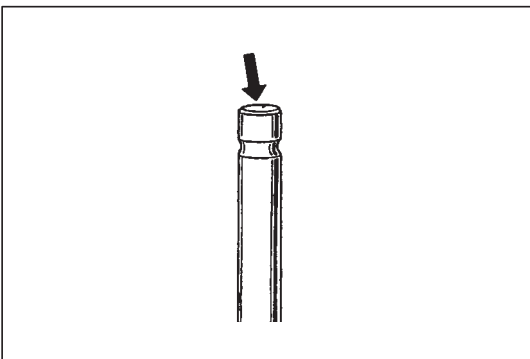
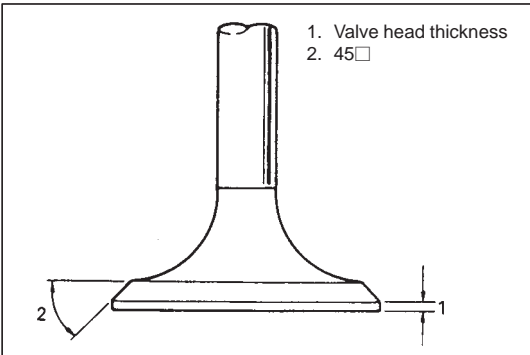
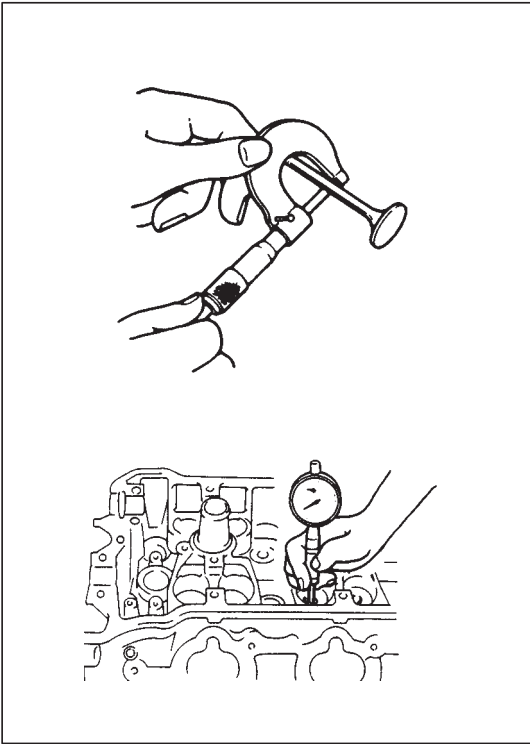

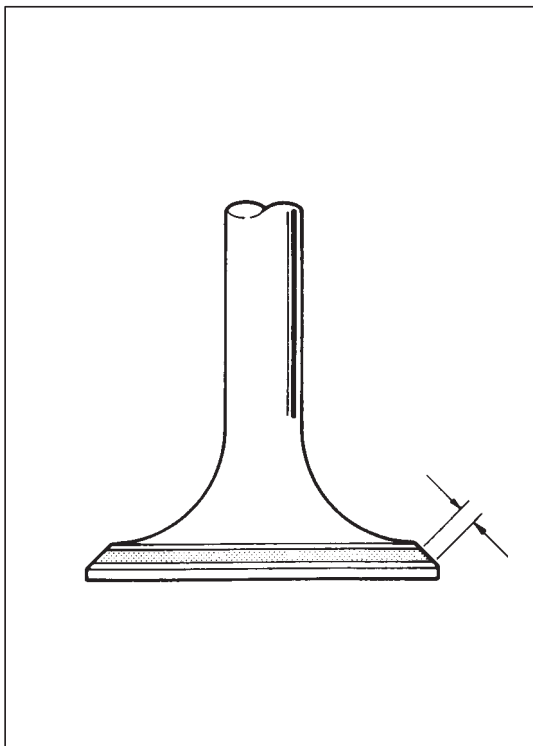

- Seating contact width:

Create contact pattern on each valve in the usual manner, i.e., by giving uniform coat of marking compound to valve seat and by rotatingly tapping seat with valve head. Valve lapper (tool used in valve lapping) must be used.

Pattern produced on seating face of valve must be a continuous ring without any break, and the width of pattern must be within specified range.

Standard seating width revealed by contact pattern on valve face	Intake	1.1 – 1.3 mm (0.0433 – 0.0512 in.)
	Exhaust	

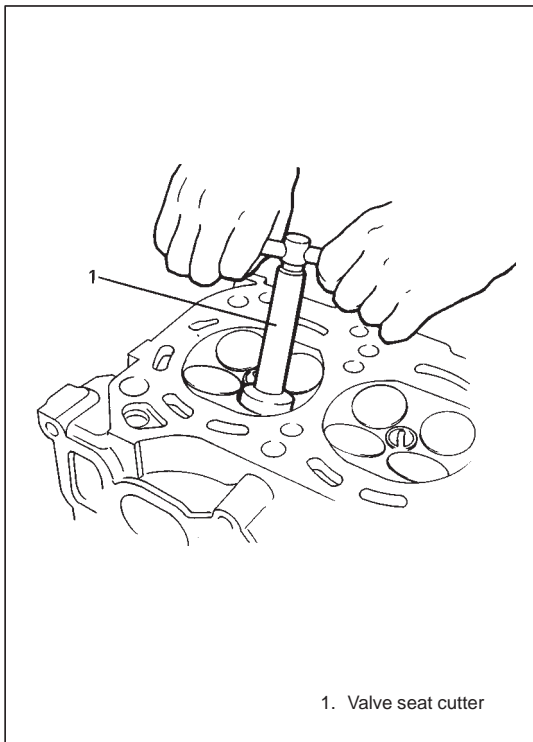

- Valve seat repair:

A valve seat not producing a uniform contact with its valve or showing width of seating contact that is out of specified range must be repaired by regrinding or by cutting and regrinding and finished by lapping.

- 1) VALVE SEAT: Use valve seat cutters to make two cuts as illustrated in figure. Two cutters must be used: the first for making 15° angle, and the second for making 45° angle. The second cut must be made to produce desired seat width.

**Seat width for valve seat:**

**1.1 – 1.3 mm (0.0433 – 0.0512 in.)**

- 2) INTAKE VALVE SEAT: Use valve seat cutters to make three cuts as illustrated in figure. Three cutters must be used: the 1st for making 15° angle, the 2nd for making 60° angle, and 3rd for making 45° angle. The 3rd cut (45°) must be made to produce desired seat width.

**Seat width for intake valve seat:**

**1.1 – 1.3 mm (0.0433 – 0.0512 in.)**

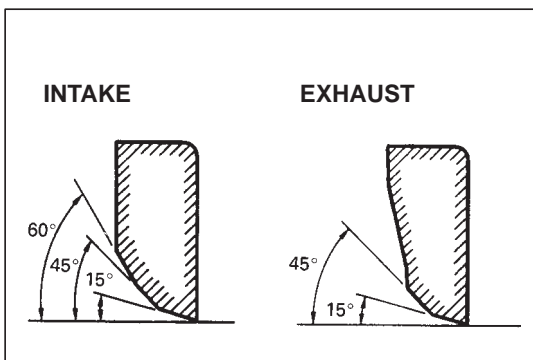

- 3) VALVE LAPPING: Lap valve on seat in two steps, first with coarse size lapping compound applied to face and the second with fine-size compound, each time using valve lapper according to usual lapping method.

### Cylinder Head

- Remove all carbon from combustion chambers.

#### NOTE:

**Do not use any sharp-edged tool to scrape off carbon. Be careful not to scuff or nick metal surfaces when decarboning. The same applies to valves and valve seats, too.**

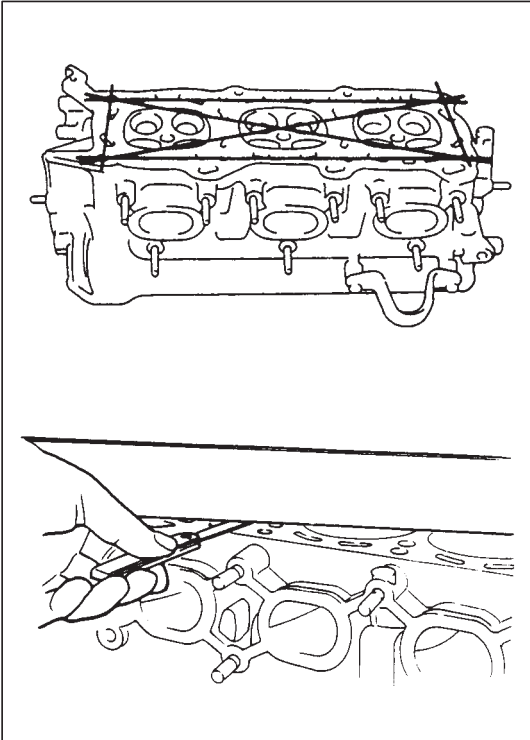
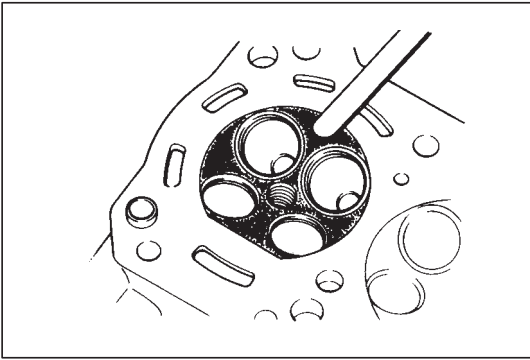

- Check cylinder head for cracks on intake and exhaust ports, combustion chambers, and head surface.

Using straightedge and thickness gauge, check flatness of gasketed surface at a total of 6 locations. If distortion limit, given below, is exceeded, correct gasketed surface with a surface plate and abrasive paper of about #400 (Waterproof silicon carbide abrasive paper): Place abrasive paper on and over surface plate, and rub gasketed surface against paper to grind off high spots. Should this fail to reduce thickness gauge readings to within limit, replace cylinder head.

Leakage of combustion gases from this gasketed joint is often due to warped gasketed surface: such leakage results in reduced power output.

**Limit of distortion: 0.05 mm (0.002 in.)**

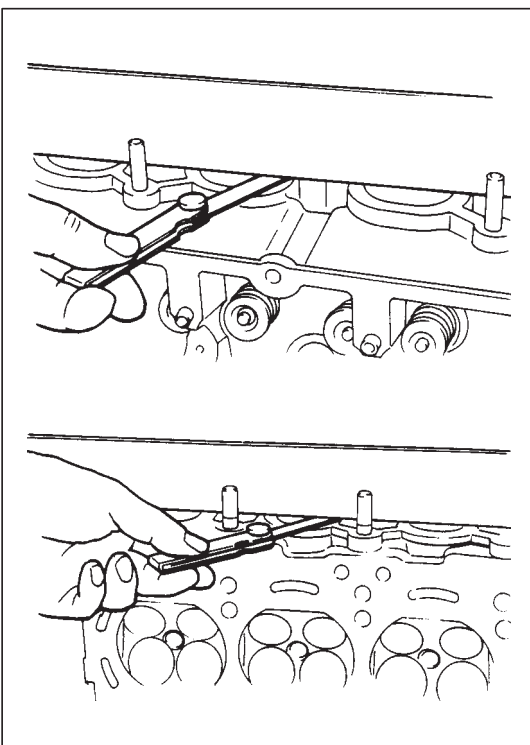

- Distortion of manifold seating faces:

Check seating faces of cylinder head for manifolds, using a straightedge and thickness gauge, in order to determine whether these faces should be corrected or cylinder head replaced.

**Limit of distortion: 0.10 mm (0.004 in.)**

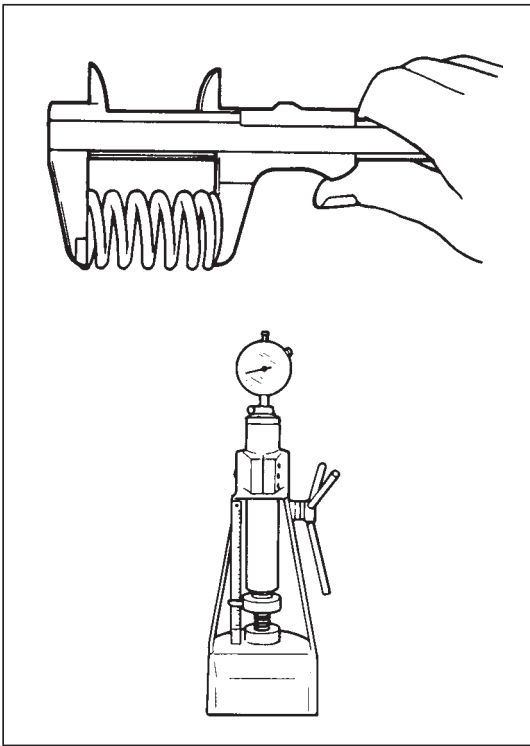

## Valve Springs

- Referring to data given below, check to be sure that each spring is in sound condition, free of any evidence of breakage or weakening. Remember, weakened valve springs can cause chatter, not to mention possibility of reducing power output due to gas leakage caused by decreased seating pressure.

Item		Standard	Limit
Valve spring free length	Inner	36.08 mm (1.4204 in.)	35.00 mm (1.3780 in.)
	Outer	40.44 mm (1.5921 in.)	39.22 mm (1.5441 in.)
Valve spring preload	Inner	6.9 – 7.9 kg for 27.5 mm (15.2 – 17.4 lb/ 1.08 in.)	5.9 kg for 27.5 mm (13.0 lb/ 1.08 in.)
	Outer	15.4 – 17.8 kg for 31.7 mm (33.9 – 39.2 lb/ 1.25 in.)	13.3 kg for 31.7 mm (30.0 lb/ 1.25 in.)

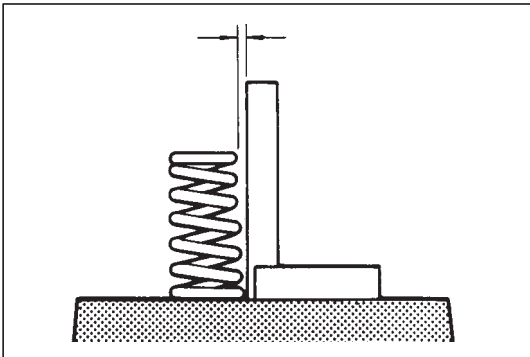

- Spring squareness:  
Use a square and surface plate to check each spring for squareness in terms of clearance between end of valve spring and square. Valve springs found to exhibit a larger clearance than limit given below must be replaced.

**Valve spring squareness limit:** Inner spring 1.6 mm (0.063 in.)  
Outer spring 1.8 mm (0.070 in.)

**ASSEMBLY**

- 1) Before installing valve guide into cylinder head, ream guide hole with special tool (11 mm reamer) so as to remove burrs and make it truly round.

**Special Tool****(E): 09916-34542****(F): 09916-38210**

- 2) Install valve guide to cylinder head.

Heat cylinder head uniformly at a temperature of 80 to 100 °C (176 to 212 °F) so that head will not be distorted, and drive new valve guide into hole with special tools. Drive in new valve guide until special tool (Valve guide installer) contacts cylinder head.

After installing, make sure that valve guide protrudes by 13.5 mm (0.53 in.) from cylinder head.

**Special Tool****(G): 09916-58210****(H): 09917-87810****NOTE:**

- Do not reuse valve guide once disassembled.  
Install new valve guide (Oversize).
- Intake and exhaust valve guides are identical.

**Valve guide oversize: 0.03 mm (0.0012 in.)**

**Valve guide protrusion (In and Ex): 13.5 mm (0.53 in.)**

1. Valve guide protrusion (13.5 mm)

- 3) Ream valve guide bore with special tool (6.0 mm reamer). After reaming, clean bore.

**Special Tool****(E): 09916-34542****(I): 09916-37810**

- 4) Install valve spring seat to cylinder head.

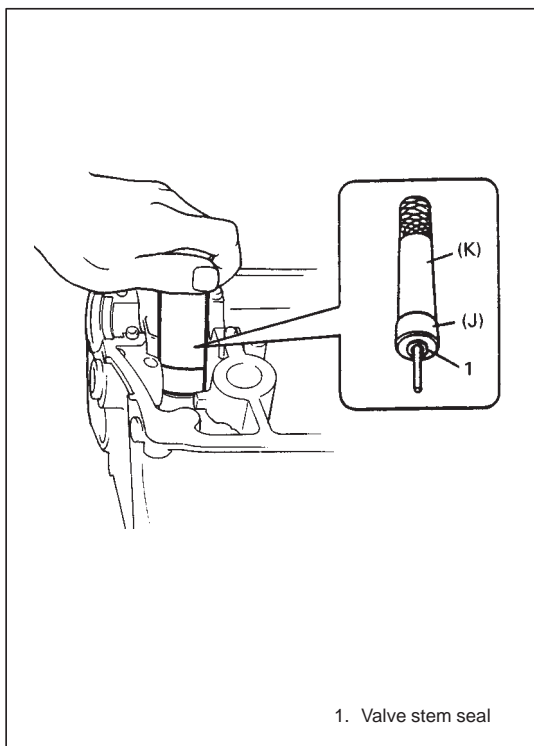

5) Install new valve stem seal to valve guide.

After applying engine oil to seal and spindle of special tool (Valve guide installer handle), fit oil seal to spindle, and then install seal to valve guide by pushing special tool by hand.

After installing, check to be sure that seal is properly fixed to valve guide.

#### Special Tool

(J): 09917-98221

(K): 09916-58210

#### NOTE:

- Do not reuse seal once disassembled. Be sure to install new seal.
- When installing, never tap or hit special tool with a hammer or else. Install seal to guide only by pushing special tool by hand. Tapping or hitting special tool may cause damage to seal.

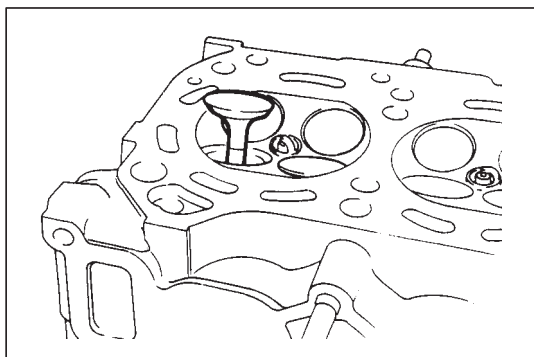

6) Install valve to valve guide.

Before installing valve to valve guide, apply engine oil to stem seal, valve guide bore, and valve stem.

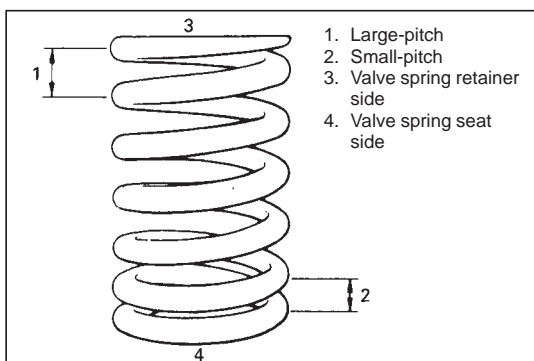

7) Install valve springs (inner and outer) and spring retainer.

Each valve spring has top end (large-pitch end) and bottom end (small-pitch end). Be sure to position spring in place with its bottom end (small-pitch end) facing the bottom (valve spring seat side).

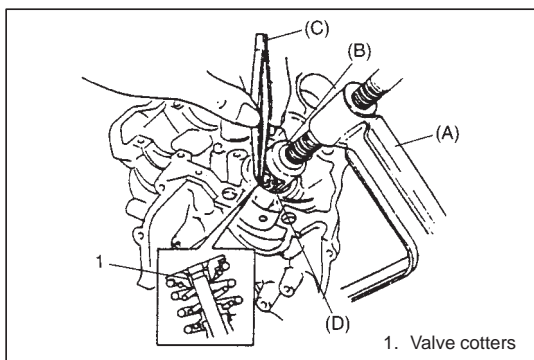

8) Using special tool (Valve lifter), compress valve spring and fit two valve cotter pins into groove in valve stem.

#### Special Tool

(A): 09916-14510

(B): 09916-14910

(C): 09916-84511

(D): 09919-28610

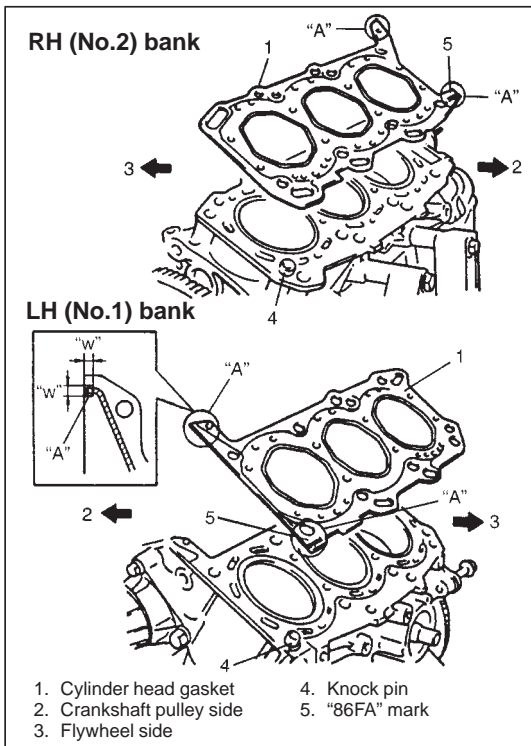

## INSTALLATION

- 1) Clean mating surface on cylinder head and cylinder block. Remove oil, old gasket and dust from mating surface.
- 2) Install knock pin to cylinder block.
- 3) Apply sealant "A" to cylinder head gasket as shown in figure.

**"A": Sealant 99000-31150**

**Width "w": Min. 4 mm (0.158 in.)**

- 4) Install new cylinder head gasket to cylinder block as shown in figure. "86FA" mark on cylinder head gasket should face up (toward cylinder head side).

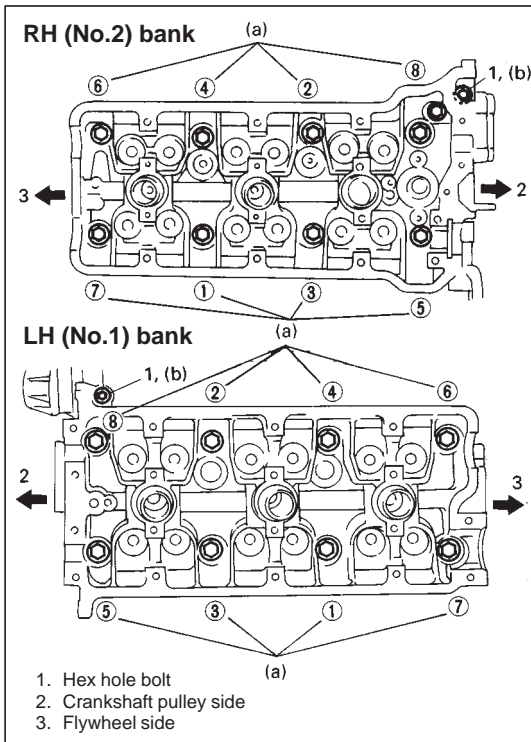

- 5) Install cylinder head to block.

After applying oil to cylinder head bolts, tighten them gradually as follows.

- (1) Tighten all bolts to 53 N·m (5.3 kg-m, 38.5 lb-ft) according to numerical order in figure.
- (2) In the same manner as in (1), tighten them to 84 N·m (8.4 kg-m, 61.0 lb-ft).
- (3) Loosen all bolts until tightening torque is reduced to 0 in reverse order of tightening.
- (4) In the same manner as in (1), tighten them to 53 N·m (5.3 kg-m, 38.5 lb-ft).
- (5) In the same manner as in (1) again, tighten them to specified torque.

### Tightening Torque

**(a): 105 N·m (10.5 kg-m, 76.0 lb-ft)**

**(b): 11 N·m (1.1 kg-m, 7.5 lb-ft)**

### NOTE:

**Don't forget to install (b) bolts as shown in figure.**

- 6) Install water outlet cap.

- 7) Check timing mark on crankshaft as shown in figure.

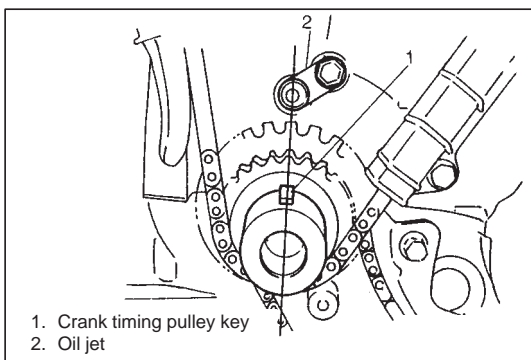

- 8) Install valve lash adjuster, camshaft, CMP sensor and RH bank 2nd timing chain.  
Refer to item "CAMSHAFT AND VALVE LASH ADJUSTER" and "RH (NO.2) BANK 2ND TIMING CHAIN AND CHAIN TENSIONER" in this section. For CMP sensor, refer to Section 6F2 for installation.
- 9) Install 1st timing chain.  
Refer to item "1ST TIMING CHAIN AND CHAIN TENSIONER" in this section for installation.
- 10) Install LH bank 2nd timing chain.  
Refer to item "LH (NO.1) BANK 2ND TIMING CHAIN AND CHAIN TENSIONER" in this section for installation.
- 11) Install timing chain cover.  
Refer to item "TIMING CHAIN COVER" in this section for installation.
- 12) Install oil pan and oil pump strainer.  
Refer to item "OIL PAN AND OIL PUMP STRAINER" in this section for installation.
- 13) Install cylinder head cover.  
Refer to item "CYLINDER HEAD COVER" in this section for installation.
- 14) Install exhaust manifold.  
Refer to item "EXHAUST MANIFOLD" in this section for installation.
- 15) Install radiator outlet pipe radiator, cooling fan and water hose.  
Refer to Section 6B installation.
- 16) Install throttle body and intake manifold.  
Refer to item "THROTTLE BODY AND INTAKE MANIFOLD" in this section for installation.
- 17) Adjust water pump drive belt tension.  
Refer to Section 6B for adjusting procedure.
- 18) Adjust power steering pump drive belt tension.  
Refer to Section 3B1 for adjusting procedure.
- 19) Adjust accelerator cable play and A/T throttle cable play. Refer to Section 6E2.
- 20) Check to ensure that all removed parts are back in place. Reinstall any necessary parts which have not been reinstalled.
- 21) Refill engine with engine oil, referring to item "ENGINE OIL CHANGE" in Section 0B.
- 22) Refill cooling system referring to Section 6B.
- 23) Refill front differential housing with gear oil if drained, referring to "DIFFERENTIAL" section.
- 24) Connect negative cable at battery.
- 25) Check ignition timing and adjust as necessary, referring to Section 6F2.
- 26) Verify that there is no fuel leakage, water leakage, oil leakage and exhaust gas leakage at each connection.
- 27) Check wheel alignment, referring to Section 3.

## PISTON, PISTON RINGS, CONNECTING RODS AND CYLINDERS

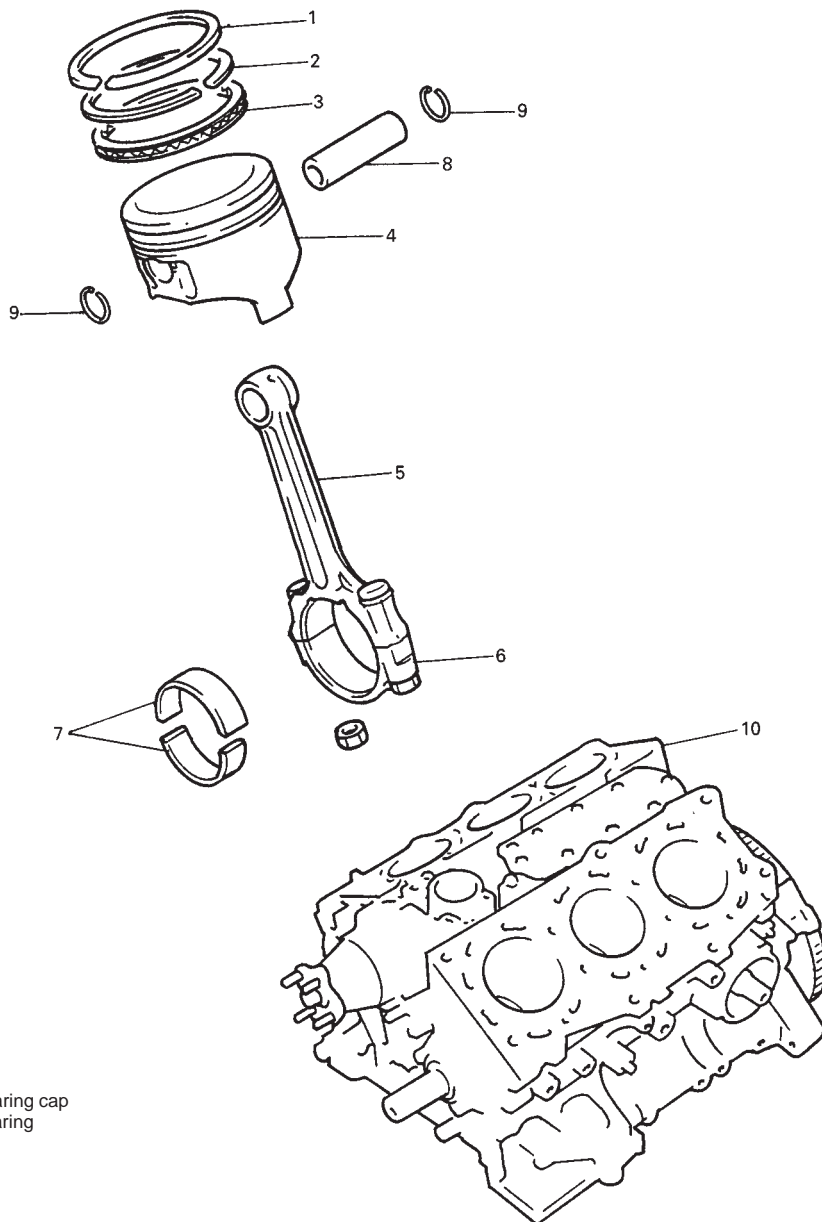

1. Top ring
2. 2nd ring
3. Oil ring
4. Piston
5. Connecting rod
6. Connecting rod bearing cap
7. Connecting rod bearing
8. Piston pin
9. Piston pin circlip
10. Cylinder block

### REMOVAL

- 1) Disconnect negative cable at battery.
- 2) Drain engine oil.
- 3) Drain coolant.
- 4) Remove cylinder heads.  
Refer to item "VALVES AND CYLINDER HEADS" in this section for removal.
- 5) Remove oil pump.  
Refer to item "OIL PUMP" in this section for removal.

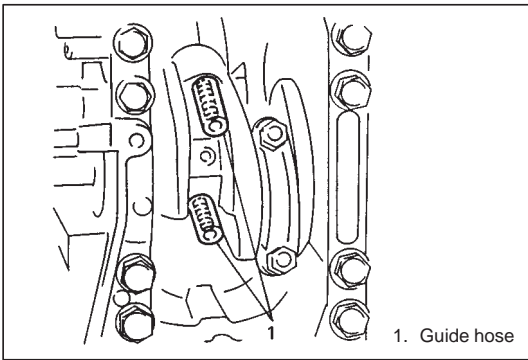

- 6) Mark cylinder number on all pistons, connecting rods and connecting rod caps.
- 7) Remove rod bearing caps.
- 8) Install guide hose over threads of rod bolts.  
This prevents damage to bearing journal and rod bolt threads when removing connecting rod.
- 9) Clean carbon from top of cylinder bore before removing piston from cylinder.
- 10) Push piston and connecting rod assembly out through the top of cylinder bore.

### DISASSEMBLY

- 1) Using piston ring expander, remove two compression rings (Top and 2nd) and oil ring from piston.

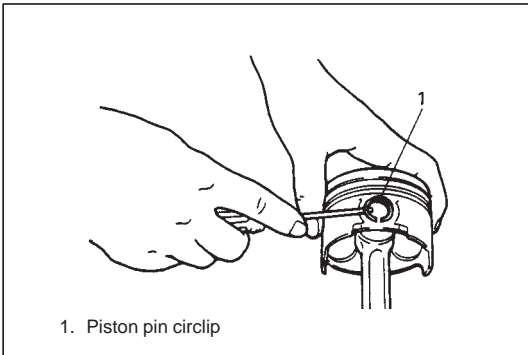

- 2) Remove piston pin from connecting rod.
  - Ease out piston pin circlips, as shown.

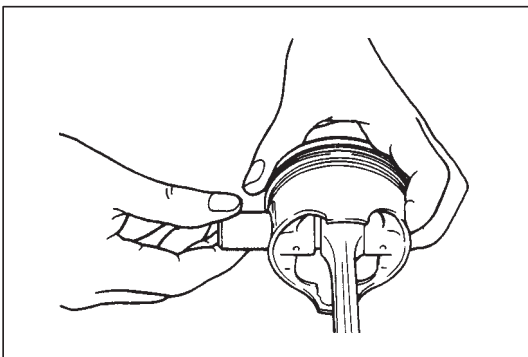

- Force piston pin out.

### CLEANING

Clean carbon from piston head and ring grooves, using a suitable tool.

## INSPECTION

### Cylinders

- Inspect cylinder walls for scratches, roughness, or ridges which indicate excessive wear. If cylinder bore is very rough or deeply scratched, or ridged, rebore cylinder and use over size piston.

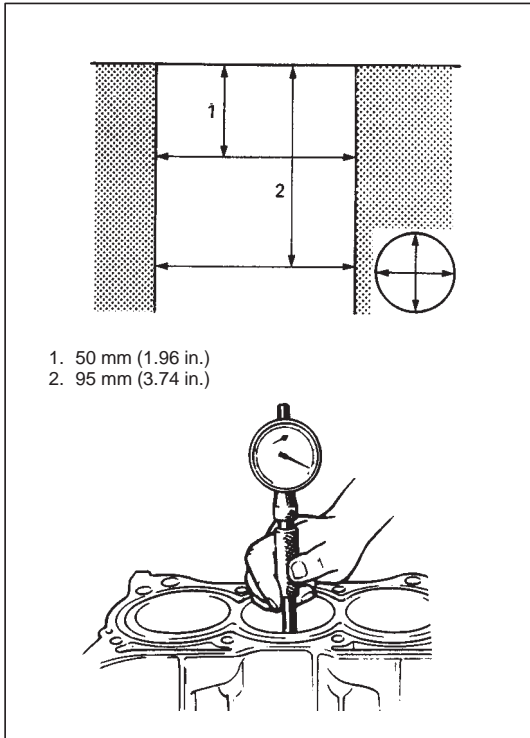

1. 50 mm (1.96 in.)
2. 95 mm (3.74 in.)

- Using a cylinder gauge, measure cylinder bore in thrust and axial directions at two positions as shown in figure.

If any of the following conditions is noted, rebore cylinder.

1. Cylinder bore dia. exceeds limit.
2. Difference of measurements at two positions exceeds taper limit.
3. Difference between thrust and axial measurements exceeds out-of-round limit.

**Cylinder bore dia. limit: 84.050 mm (3.3090 in.)**

**Taper and out-of-round limit: 0.10 mm (0.004 in.)**

#### NOTE:

**If any one of six cylinders has to be rebored, rebore all six to the same next oversize. This is necessary for the sake of uniformity and balance.**

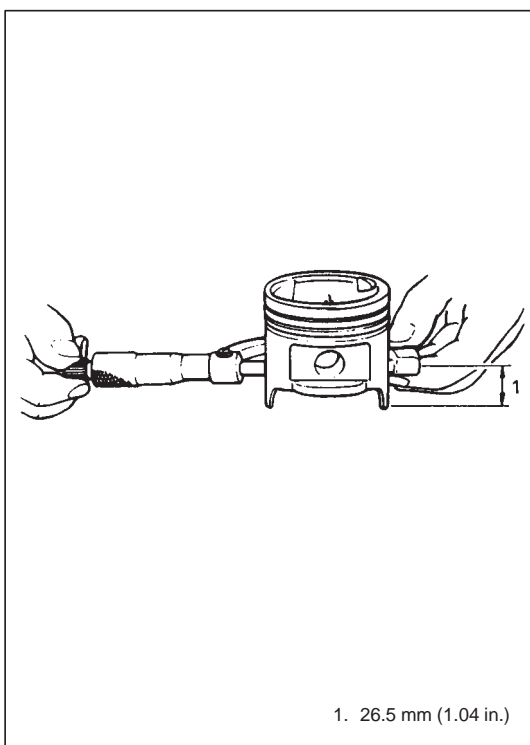

1. 26.5 mm (1.04 in.)

### Pistons

- Inspect piston for faults, cracks or other damages.

Damaged or faulty piston should be replaced.

- Piston diameter:

As indicated in figure, piston diameter should be measured at a position 26.5 mm (1.04 in.) from piston skirt end in the direction perpendicular to piston pin.

Piston diameter	Standard	83.970 – 83.990 mm (3.3059 – 3.3067 in.)
	Oversize: 0.25 mm (0.0098 in.)	84.220 – 84.240 mm (3.3157 – 3.3165 in.)
	0.50 mm (0.0196 in.)	84.470 – 84.490 mm (3.3256 – 3.3264 in.)

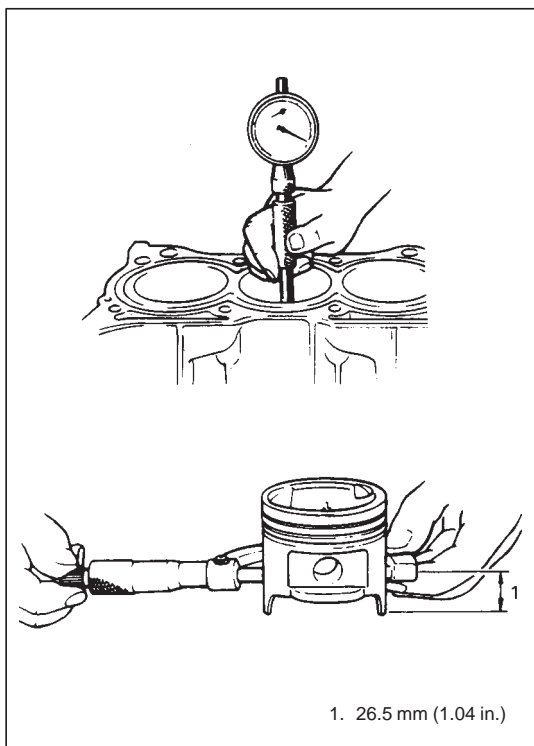

- **Piston clearance:**

Measure cylinder bore diameter and piston diameter to find their difference which is piston clearance. Piston clearance should be within specification as given below. If it is out of specification, re-bore cylinder and use oversize piston.

**Piston clearance: 0.02 – 0.04 mm (0.0008 – 0.0015 in.)**

**NOTE:**

**Cylinder bore diameters used here are measured in thrust direction at two positions.**

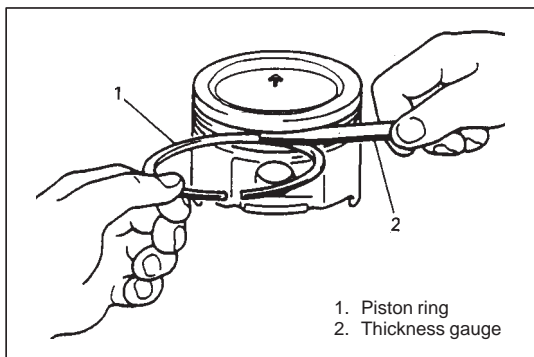

- **Ring groove clearance:**

Before checking, piston grooves must be clean, dry and free of carbon.

Fit new piston ring into piston groove, and measure clearance between ring and ring land by using thickness gauge. If clearance is out of specification, replace piston.

**Ring groove clearance:**

**Top: 0.03 – 0.07 mm (0.0012 – 0.0027 in.)**

**2nd: 0.02 – 0.06 mm (0.0008 – 0.0023 in.)**

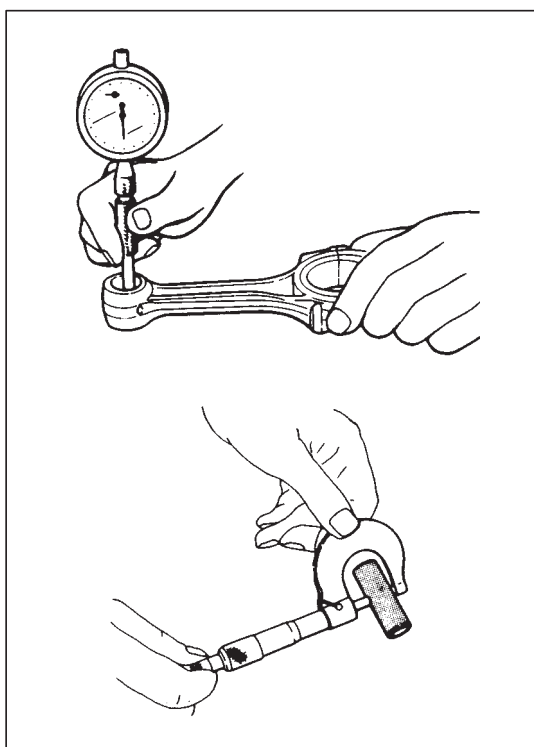

**Piston Pin**

- Check piston pin, connecting rod small-end bore and piston bore for wear or damage, paying particular attention to condition of small-end bore bush. If pin, connecting rod small-end bore or piston bore is badly worn or damaged, replace pin, connecting rod or piston.

- **Piston pin clearance:**

Check piston pin clearance in small-end. Replace connecting rod if its small end is badly worn or damaged or if measured clearance exceeds limit.

Item	Standard
Piston clearance in small end	0.003 – 0.014 mm (0.0001 – 0.0005 in.)

**Small-end bore:**

**21.003 – 21.011 mm (0.8269 – 0.8272 in.)**

**Piston pin dia.:**

**20.997 – 21.000 mm (0.8266 – 0.8268 in.)**

### Piston Rings

To measure end gap, insert piston ring into cylinder bore and then measure the gap by using thickness gauge.

If measure gap is out of specification, replace ring.

#### NOTE:

**Clean carbon and any other dirt from top of cylinder bore before inserting piston ring.**

Item		Standard	Limit
Piston ring end gap	Top ring	0.20 – 0.35 mm (0.0079 – 0.0137 in.)	0.7 mm (0.0276 in.)
	2nd ring	0.35 – 0.50 mm (0.0138 – 0.0196 in.)	0.7 mm (0.0276 in.)
	Oil ring	0.20 – 0.70 mm (0.0079 – 0.0275 in.)	1.8 mm (0.0709 in.)

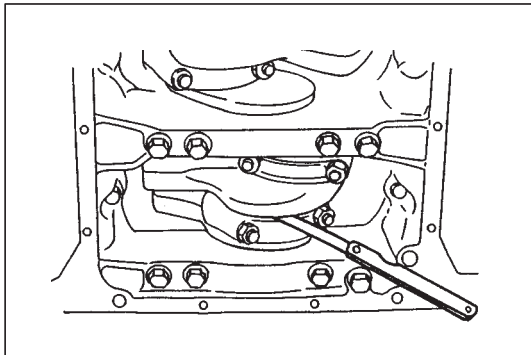
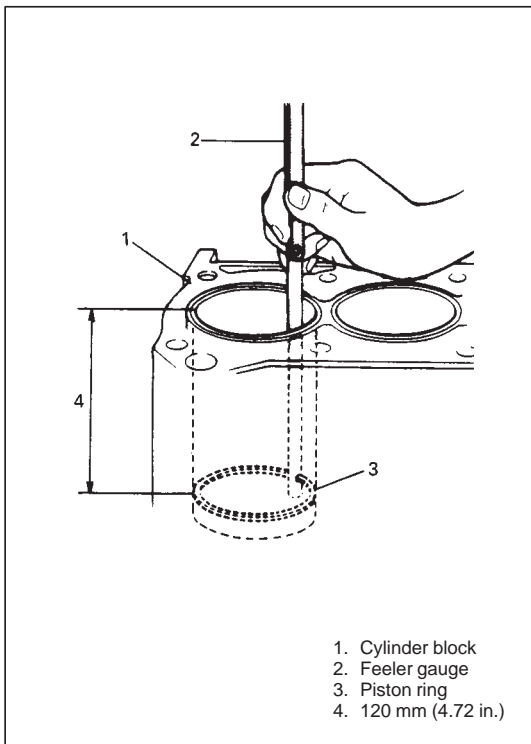

### Connecting Rod

#### ● Big-end side clearance:

Check big-end of connecting rod for side clearance, with rod fitted and connected to its crank pin in the normal manner. If measured clearance is found to exceed its limit, replace connecting rod.

Item	Standard	Limit
Big-end side clearance	0.25 – 0.40 mm (0.0099 – 0.0157 in.)	0.45 mm (0.0177 in.)

#### ● Connecting rod alignment:

Mount connecting rod on aligner to check it for bow and twist. If limit is exceeded, replace it.

**Limit on bow: 0.05 mm (0.0020 in.)**

**Limit on twist: 0.10 mm (0.0039 in.)**

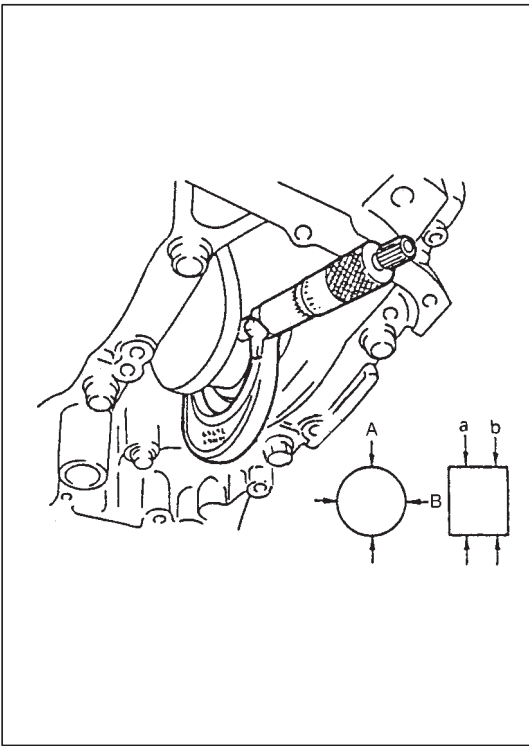

### Crank Pin and Connecting Rod Bearings

- Inspect crank pin for uneven wear or damage. Measure crank pin for out-of-round or taper with a micrometer. If crank pin is damaged, or out-of-round or taper is out of limit, replace crankshaft or regrind crank pin referring to following step 6).

Connecting rod bearing size	Crank pin diameter
Standard	49.982 – 50.000 mm (1.9678 – 1.9685 in.)
0.25 mm (0.0098 in.) undersize	49.732 – 49.750 mm (1.9580 – 1.9586 in.)

**Out-of-round: A – B**

**Taper limit : a – b**

**Out-of-round and taper limit: 0.01 mm (0.0004 in.)**

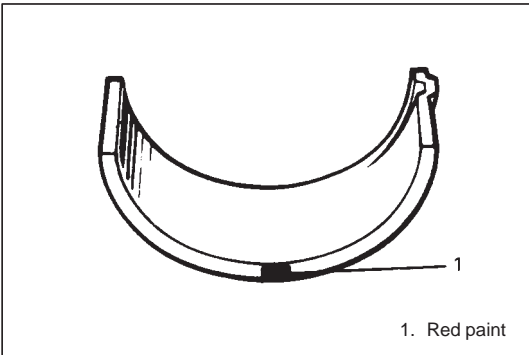

- Rod bearing:

Inspect bearing shells for signs of fusion, pitting, burn or flaking and observe contact pattern. Bearing shells found in defective condition must be replaced.

Two kinds of rod bearing are available; standard size bearing and 0.25 mm undersize bearing. For identification of undersize bearing, it is painted red at the position as indicated in figure, undersize bearing thickness is 1.605 – 1.615 mm (0.0632 – 0.0635 in.) at the center of it.

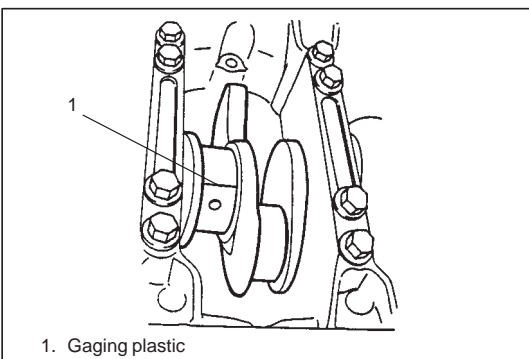

- Rod bearing clearance:

- 1) Before checking bearing clearance, clean bearing and crank pin.
- 2) Install bearing in connecting rod and bearing cap.
- 3) Place a piece of gaging plastic to full width of crank pin as contacted by bearing (parallel to crankshaft), avoiding oil hole.

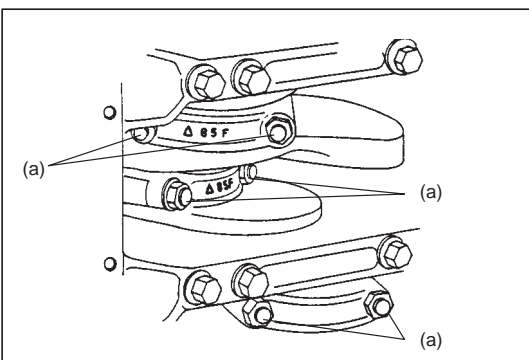

- 4) Install rod bearing cap to connecting rod.

When installing cap, be sure to point arrow mark on cap to crankshaft pulley side, as shown in figure. After applying engine oil to rod bolts, tighten cap nuts to specified torque. DO NOT turn crankshaft with gaging plastic installed.

### Tightening Torque

**(a): 45 N·m (4.5 kg-m, 32.5 lb-ft)**

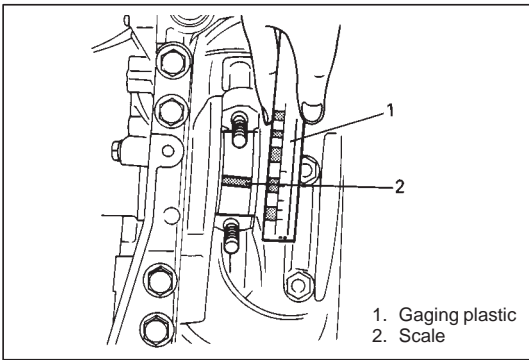

- 5) Remove cap and using a scale on gaging plastic envelope, measure gaging plastic width at the widest point (clearance). If clearance exceeds its limit, use a new standard size bearing and remeasure clearance.

Item	Standard	Limit
Bearing clearance	0.045 – 0.063 mm (0.0018 – 0.0025 in.)	0.08 mm (0.0031 in.)

- 6) If clearance can not be brought to within its limit even by using a new standard size bearing, regrind crank pin to undersize as follows.
- Install 0.25 mm undersize bearing to connecting rod big end.
  - Measure bore diameter of connecting rod big end.
  - Regrind crank pin to following finished diameter:

$$\boxed{\text{Finished crank pin dia.}} = \boxed{\text{Measured big end bore dia. (including under-size bearing)}} - \boxed{0.054 \text{ mm (0.0021 in.)}}$$

- Confirm that bearing clearance is within above standard value.

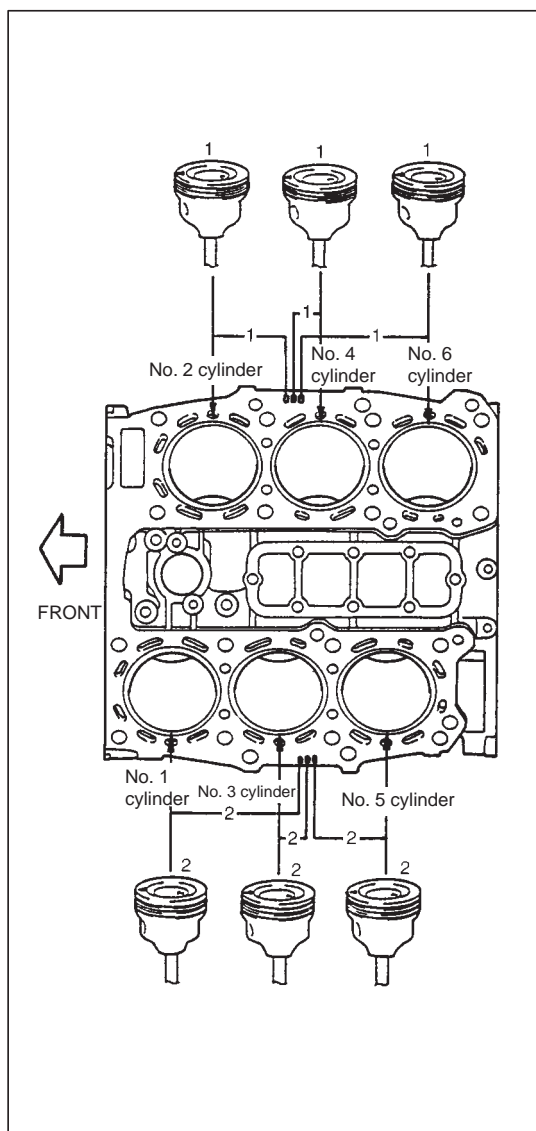

## ASSEMBLY

### NOTE:

Two sizes of piston are available as standard size spare part so as to ensure proper piston-to-cylinder clearance. When installing a standard size piston, make sure to match piston with cylinder as follows.

- Each piston has stamped number (1 or 2) on its piston head. It represents outer diameter of piston.
- There are also stamped numbers of 1 and 2 on the cylinder block as shown.
- Stamped number on piston and cylinder block must correspond. That is, install number "2" stamped piston to cylinder which is stamped also number "2" and a number "1" piston to cylinder with number "1".

Piston		Cylinder		Piston-to-cylinder clearance
Number at the top (mark)	Outer diameter	Number on cylinder block	Bore diameter	
1	83.98 – 83.99 mm (3.3063 – 3.3066 in.)	1	84.01 – 84.02 mm (3.3075 – 3.3078 in.)	0.02 – 0.04 mm (0.0008 – 0.0015 in.)
2	83.97 – 83.98 mm (3.3059 – 3.3062 in.)	2	84.00 – 84.01 mm (3.3071 – 3.3074 in.)	0.02 – 0.04 mm (0.0008 – 0.0015 in.)

Also, a letter A, B or C is stamped on piston head but ordinarily it is not necessary to distinguish each piston by this letter.

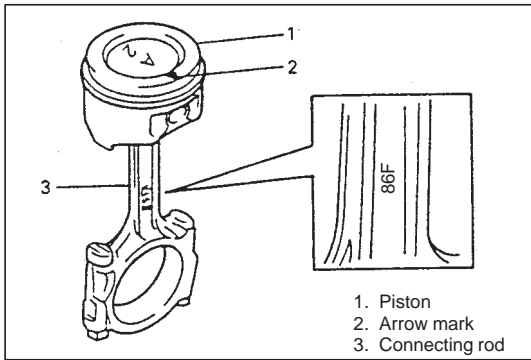

## 1) Install piston pin to piston and connecting rod:

After applying engine oil to piston pin and piston pin holes in piston and connecting rod, fit connecting rod to piston as shown in figure and insert piston pin to piston and connecting rod, and install piston pin circlips.

**NOTE:**

- "86F" mark on connecting rod must face toward crankshaft pulley side.

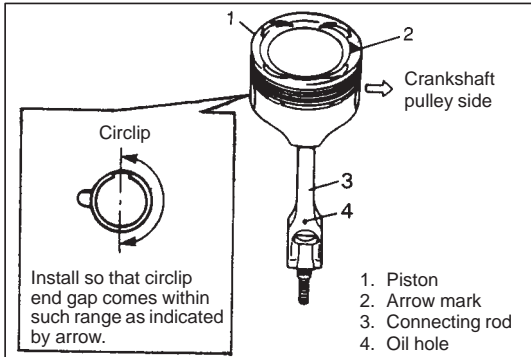

- Install circlip with its cut part facing as shown in figure.

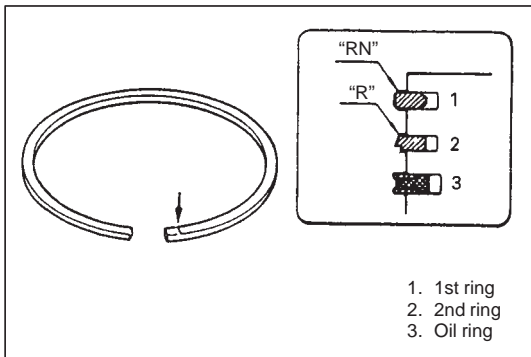

## 2) Install piston rings to piston:

- As indicated in figure at the left, 1st and 2nd rings have "RN" or "R" mark respectively. When installing these piston rings to piston, direct marked side of each ring toward top of piston.
- 1st rings differs from 2nd ring in thickness, shape and color of surface contacting cylinder wall.
- Distinguish 1st from 2nd ring by referring to figure.
- When installing oil ring, install spacer first and then two rails.

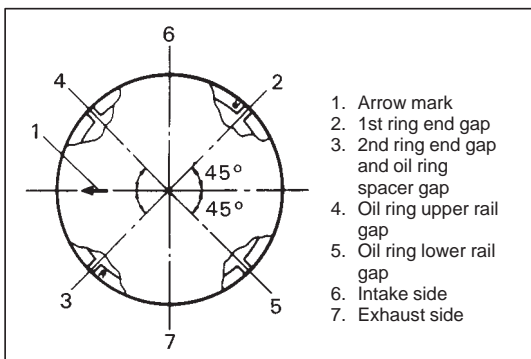

## 3) After installing three rings (1st, 2nd and oil rings), distribute their end gaps as shown in figure.

## INSTALLATION

- 1) Apply engine oil to pistons, rings, cylinder walls, connecting rod bearings and crank pins.

### NOTE:

**Do not apply oil between connecting rod and bearing or between bearing cap and bearing.**

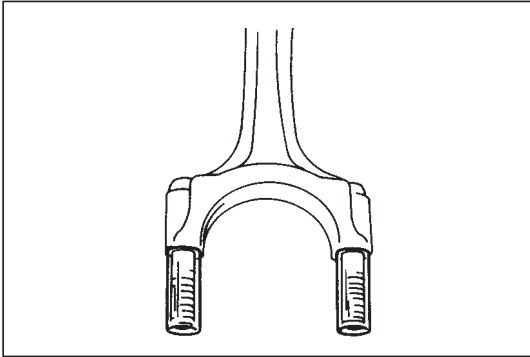

- 2) Install guide hoses over connecting rod bolts.  
These guide hoses protect crank pin and threads of rod bolt from damage during installation of connecting rod and piston assembly.

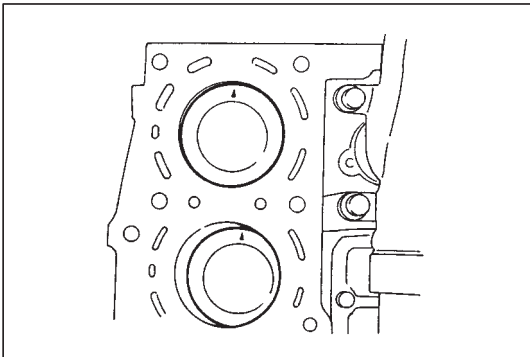

- 3) When installing piston and connecting rod assembly into cylinder bore, point arrow mark on piston head to crankshaft pulley side.

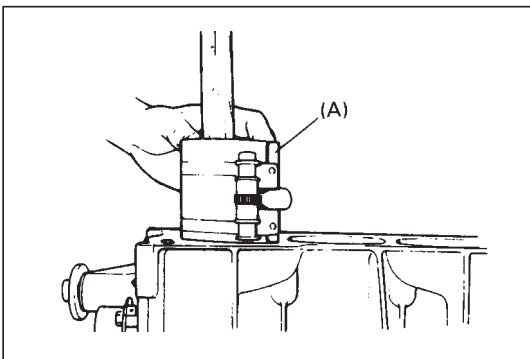

- 4) Install piston and connecting rod assembly into cylinder bore. Use special tool (Piston ring compressor) to compress rings. Guide connecting rod into place on crankshaft. Using a hammer handle, tap piston head to install piston into bore. Hold ring compressor firmly against cylinder block until all piston rings have entered cylinder bore.

### Special Tool

**(A): 09916-77310**

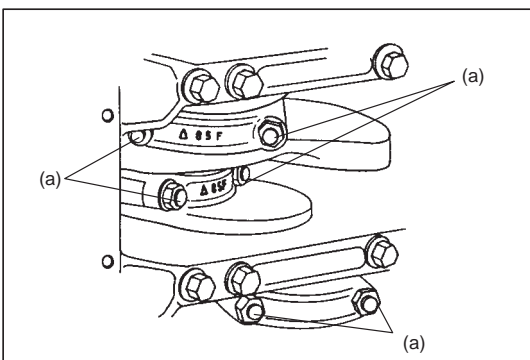

- 5) Install bearing cap:  
Point arrow mark on cap to crankshaft pulley side.  
Tighten cap nuts to specification.

### Tightening Torque

**(a): 45 N·m (4.5 kg-m, 32.5 lb-ft)**

- 6) Install cylinder heads and oil pump to cylinder block.  
Refer to item "VALVES AND CYLINDER HEADS" and "OIL PUMP" in this section.
- 7) Install valve lash adjusters, camshafts and RH bank 2nd timing chain.  
Refer to item "CAMSHAFT AND VALVE LASH ADJUSTER" and "RH (NO.2.) BANK 2ND TIMING CHAIN AND CHAIN TENSIONER" in this section for installation.
- 8) Install 1st timing chain.  
Refer to item "1ST TIMING CHAIN AND CHAIN TENSIONER" in this section for installation.
- 9) Install LH bank 2nd timing chain.  
Refer to item "LH (NO.1) BANK 2ND TIMING CHAIN AND CHAIN TENSIONER" in this section for installation.
- 10) Install timing chain cover.  
Refer to item "TIMING CHAIN COVER" in this section for installation.
- 11) Install oil pan and pump strainer.  
Refer to item "OIL PAN AND OIL PUMP STRAINER" in this section for installation.
- 12) Install cylinder head cover.  
Refer to item "CYLINDER HEAD COVER" in this section for installation.
- 13) Install exhaust manifold.  
Refer to item "EXHAUST MANIFOLD" in this section for installation.
- 14) Install radiator outlet pipe, radiator, cooling fan and water hose.  
Refer to Section 6B for installation.
- 15) Install throttle body and intake manifold.  
Refer to item "THROTTLE BODY AND INTAKE MANIFOLD" in this section for installation.
- 16) Adjust water pump drive belt tension.  
Refer to Section 6B for adjusting procedure.
- 17) Adjust power steering pump drive belt tension.  
Refer to Section 3B1 for adjusting procedure.
- 18) Adjust accelerator cable play and A/T throttle cable play. Refer to Section 6E2.
- 19) Check to ensure that all removed parts are back in place.  
Reinstall any necessary parts which have not been reinstalled.
- 20) Refill engine with engine oil, referring to item "ENGINE OIL CHANGE" in Section 0B.
- 21) Refill cooling system referring to Section 6B.
- 22) Refill front differential housing with gear oil if drained, referring to "DIFFERENTIAL" section.
- 23) Connect negative cable at battery.
- 24) Check ignition timing and adjust as necessary, referring to Section 6F2.
- 25) Verify that there is no fuel leakage, water leakage, oil leakage and exhaust gas leakage at each connection.
- 26) Check wheel alignment, referring to Section 3.

## UNIT REPAIR OVERHAUL

### ENGINE ASSEMBLY

#### REMOVAL

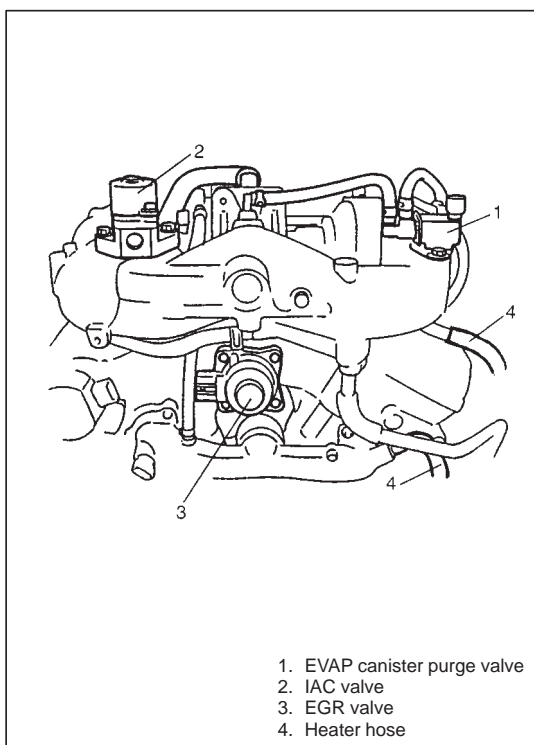
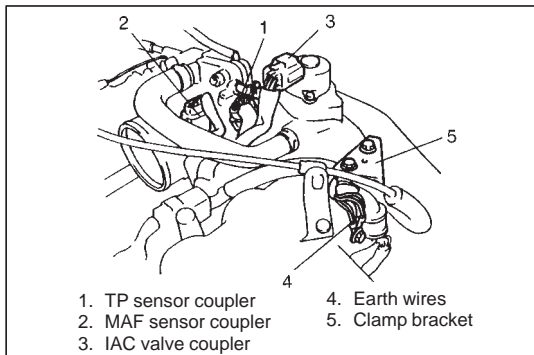
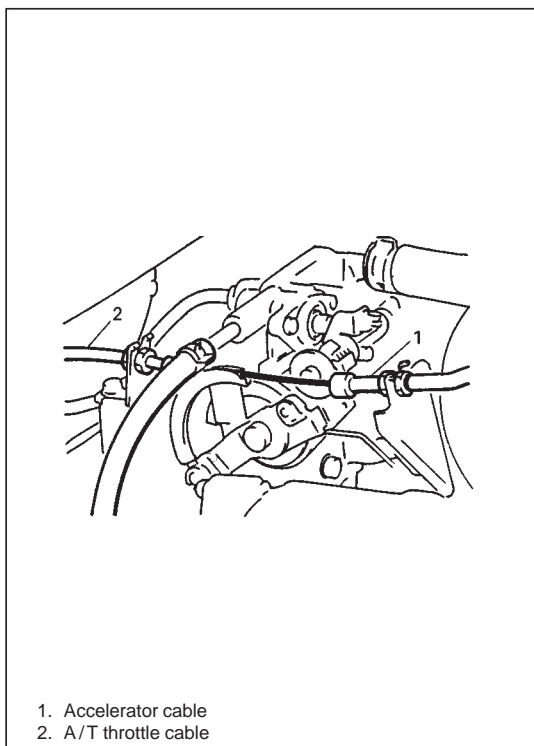

- 1) Release fuel pressure in fuel feed line.  
Refer to Section 6.
- 2) Disconnect negative cable at battery.
- 3) Remove engine hood.
- 4) Drain engine oil.
- 5) Drain coolant.
- 6) Remove radiator, radiator fan shroud, cooling fan and radiator reservoir. Refer to Section 6B for removal.
- 7) Disconnect accelerator cable and A/T throttle cable (for A/T vehicle) from throttle body.
- 8) Remove strut tower bar and surge tank cover.
- 9) Disconnect IAT sensor coupler then remove air cleaner upper case, intake air hose, intake air pipe and surge tank pipe as a component.
- 10) Remove engine oil level gauge guide and A/T fluid level gauge guide (for A/T vehicle).
- 11) Remove ignition coil covers.
- 12) Disconnect following electric lead wires:
  - Injector wire coupler
  - CMP sensor coupler
  - Ignition coil couplers
  - CKP sensor coupler
  - MAP sensor coupler
  - TP sensor coupler
  - MAF sensor coupler
  - IAC valve coupler
  - Earth wire from surge tank
  - EVAP canister purge valve coupler
  - EGR valve coupler
  - Oxygen sensor -1 and -2 couplers (Refer to "Exhaust Manifold" in this section for disconnection)
  - Coolant temperature sensor coupler
  - Generator wires
  - Startor wires
  - Oil pressure wire
  - P/S pump wire
  - Earth wire from generator bracket
- 13) Remove clamps and brackets.
- 14) Disconnect following hoses:
  - Heater hose from heater water pipe
  - Heater hose from water outlet cap
  - EVAP canister hose from canister pipe
  - Brake booster vacuum hose
  - Tank pressure control solenoid valve hose from intake manifold
- 15) Remove IAC valve and EVAP canister purge valve.

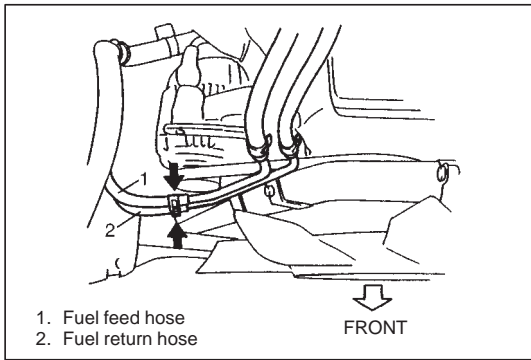

- 16) Disconnect following hoses at the location shown in figure:
  - Fuel feed hose from fuel feed pipe
  - Fuel return hose from fuel return pipe
- 17) Remove EVAP canister.

- 18) Remove P/S pump ass'y. Refer to Section 3B1 for details.
- 19) Remove A/C compressor ass'y. Refer to Section 1B for details.
- 20) Remove steering shaft lower assembly. Refer to Section 3C/3C1 for details.

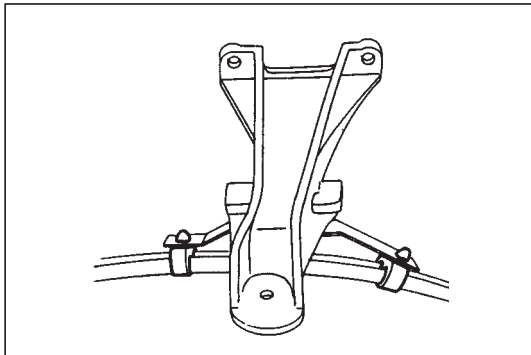

- 21) Raise vehicle.
- 22) Remove front differential housing with differential from chassis if equipped. Refer to Section 7E for removal.
- 23) Remove exhaust No.1 pipe. Refer to item "EXHAUST MAN-IFOLD" in this section for removal.
- 24) Remove exhaust manifold stiffener from transmission.
- 25) Remove A/T fluid hose clamps from engine mounting bracket. (for A/T vehicle)

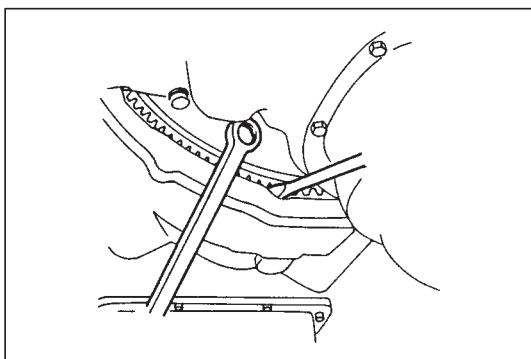

- 26) Remove clutch housing lower plate.
- 27) Remove torque converter bolts (for A/T vehicle).
- 28) Remove starter motor.
- 29) Lower vehicle.

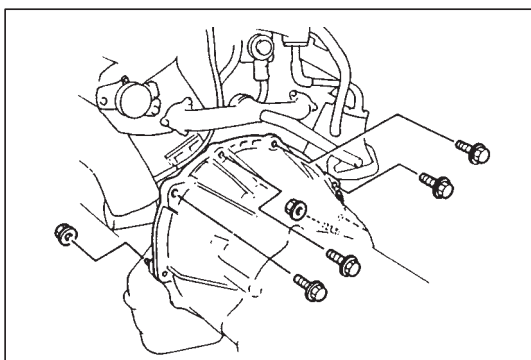

- 30) Support transmission. For A/T vehicle, don't jack under A/T oil pan to support transmission.
- 31) Remove bolts and nuts fastening cylinder block and transmission.

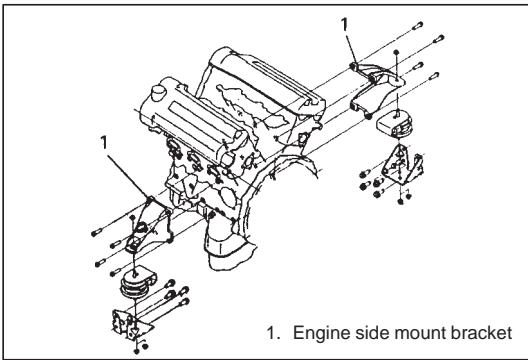

- 32) Install lifting device.
- 33) Disconnect engine side mounting brackets to engine mountings.

- 34) Before lifting engine, check to ensure all hoses, wires and cables are disconnected from engine.
- 35) Remove engine assembly from chassis and transmission by sliding toward front, and then, carefully hoist engine assembly.

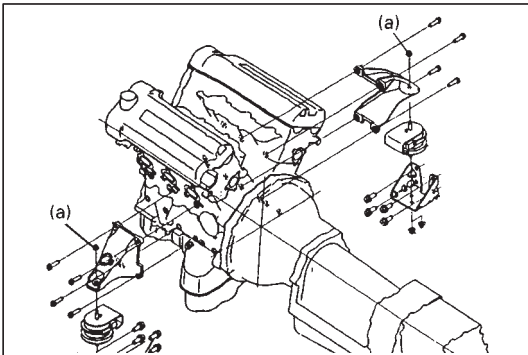

## INSTALLATION

Reverse removal procedure for installation, noting following points.

- 1) Lower engine assembly into engine compartment. Connect engine to transmission and engine side mounting brackets to engine mountings.
- 2) Tighten nuts fastening engine side mounting brackets and engine mountings.

### Tightening Torque

**(a): 50 N·m (5.0 kg-m, 36.5 lb-ft)**

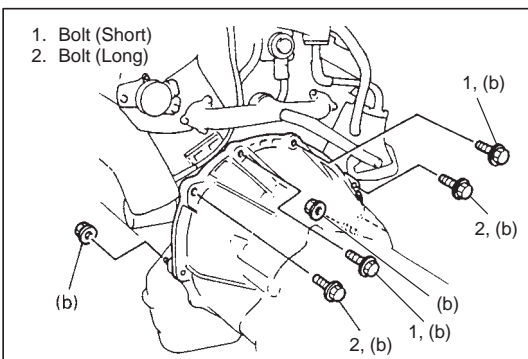

- 3) Tighten bolts and nuts fastening cylinder block and transmission to specified torque.

### Tightening Torque

**(b): 85 N·m (8.5 kg-m, 61.5 lb-ft)**

- 4) Remove lifting device

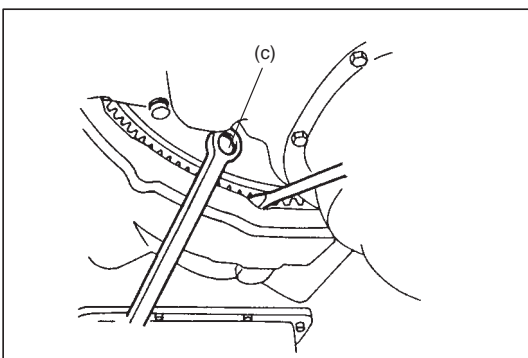

- 5) Tighten torque converter bolts to specified torque (for A/T vehicle).

### Tightening Torque

**(c): 65 N·m (6.5 kg-m, 47.0 lb-ft)**

Type 1

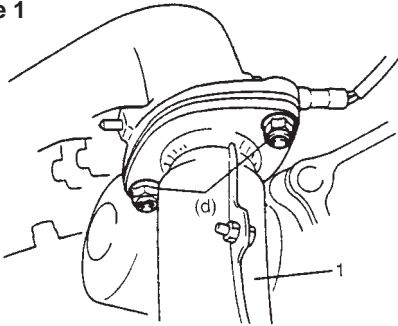

Type 2

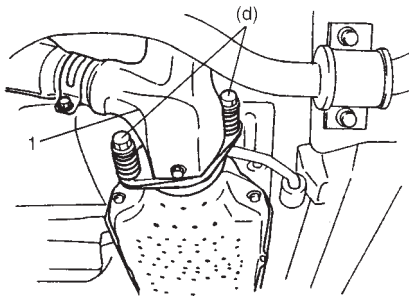
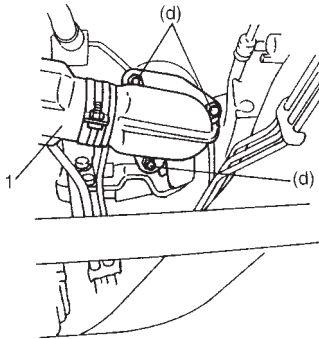

1. Exhaust No.1 pipe

- 6) Tighten bolts and nuts of exhaust No.1 pipe to specified torque.

### Tightening Torque

(d): 50 N·m (5.0 kg·m, 36.5 lb-ft)

- 7) Install front differential housing with differential to chassis if removed. Refer to Section 7E for installation.
- 8) Install steering shaft lower assembly. Refer to Section 3C/3C1 for details.
- 9) Install A/C compressor ass'y. Refer to Section 1B for details.
- 10) Install P/S pump ass'y. Refer to Section 3B1 for details.
- 11) Connect hoses, cables and electric wires.
- 12) Adjust accelerator cable and A/T throttle cable (for A/T vehicle) according to procedure described in Section 6E2.
- 13) Refill engine with engine oil referring to item "ENGINE OIL CHANGE" in Section 0B.
- 14) Refill cooling system, referring to Section 6B.
- 15) Check to ensure that all fasteners and clamps are tightened.
- 16) Upon completion of installation, verify that there is no fuel leakage, coolant leakage, P/S fluid leakage or exhaust gas leakage at each connection.

## MAIN BEARINGS, CRANKSHAFT AND CYLINDER BLOCK

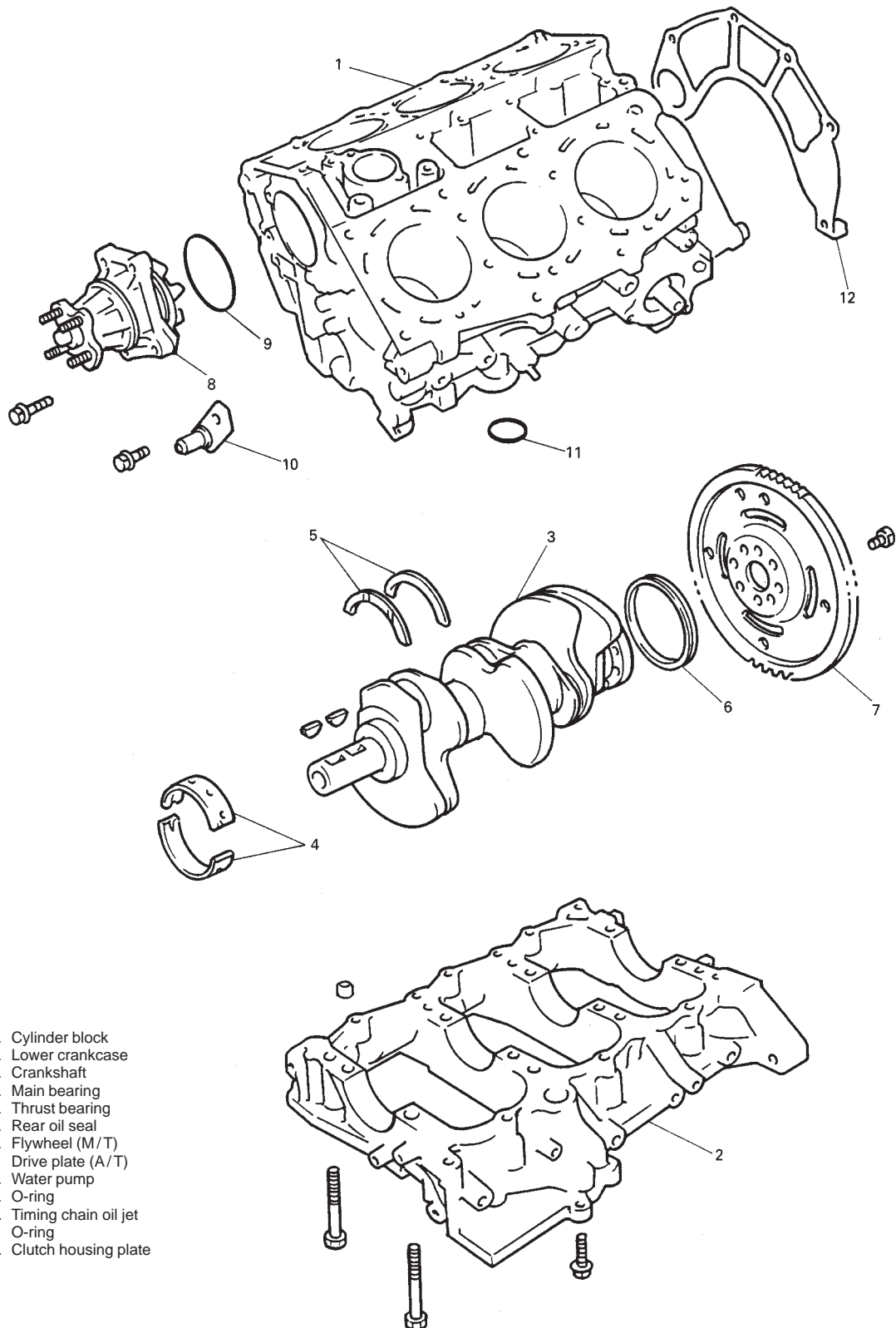

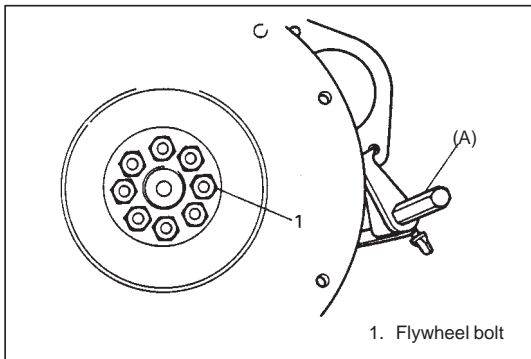

## REMOVAL

- 1) Remove engine assembly from vehicle as previously outlined.
- 2) Remove clutch and flywheel (for M/T vehicle) or drive plate (for A/T vehicle). For clutch removal, refer to Section 7C1. Using special tool (flywheel holder), remove flywheel (M/T vehicle) or drive plate (A/T vehicle).

### Special Tool

(A): 09924-17810

- 3) Remove throttle body, intake manifold, exhaust manifolds.
- 4) Remove oil pans (lower and upper) and oil pump strainer. Refer to item "OIL PAN AND OIL PUMP STRAINER" in this section for removal.
- 5) Remove cylinder head cover.
- 6) Remove timing chain cover. Refer to item "TIMING CHAIN COVER" in this section for removal.
- 7) Remove timing chains and chain tensioners, LH Bank 2nd timing chain, 1st timing chain and RH Bank 2nd timing chain.
- 8) Remove cylinder head assembly.
- 9) Remove pistons and connecting rods.
- 10) Remove oil pump and oil pump chain.

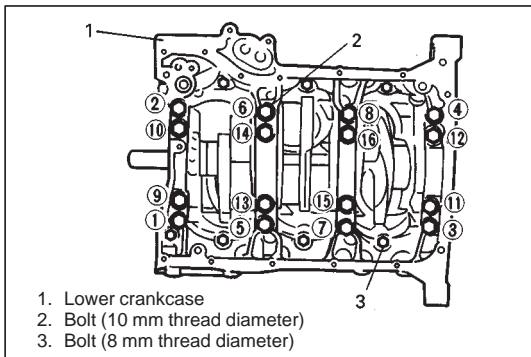

- 11) Loosen crankcase bolts, following sequence in figure and remove them.

### NOTE:

**Loosen 8 mm thread diameter bolts first, then loosen 10 mm thread diameter bolts following the order shown in figure.**

- 12) Remove crankshaft from cylinder block.

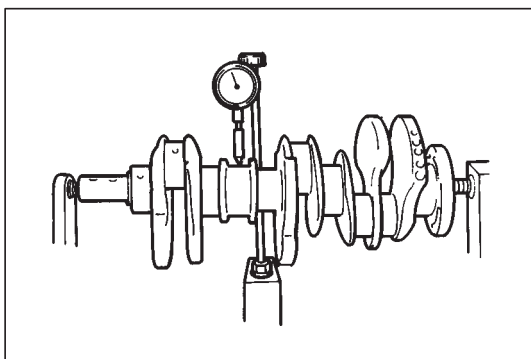

## INSPECTION

### Crankshaft runout

Using a dial gauge, measure runout at center journal. Rotate crankshaft slowly. If runout exceeds its limit, replace crankshaft.

**Limit on runout: 0.06 mm (0.0023 in.)**

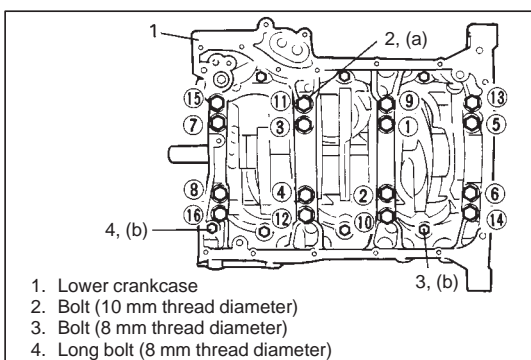

### Crankshaft thrust play

Measure this play with crankshaft set in cylinder block in the normal manner, that is, with thrust bearing and journal bearing caps installed. Tighten crankcase bolts to specified torque in such order as indicated in figure.

### NOTE:

**Tighten 10 mm thread diameter bolts first (following the order shown in figure), then tighten 8 mm thread diameter bolts.**

### Tightening Torque

(a): 60 N·m (6.0 kg-m, 43.5 lb-ft)

(b): 27 N·m (2.7 kg-m, 19.5 lb-ft)

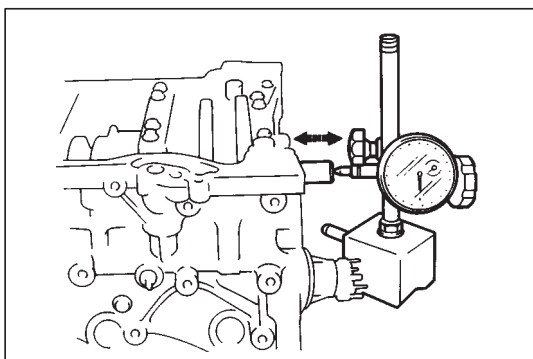

Use a dial gauge to read displacement in axial (thrust) direction of crankshaft.

If its limit is exceeded, replace thrust bearing with new standard one or oversize one to obtain standard thrust play.

### Crankshaft Thrust Play

**Standard: 0.11 – 0.31 mm (0.0044 – 0.0122 in.)**

**Limit: 0.38 mm (0.0149 in.)**

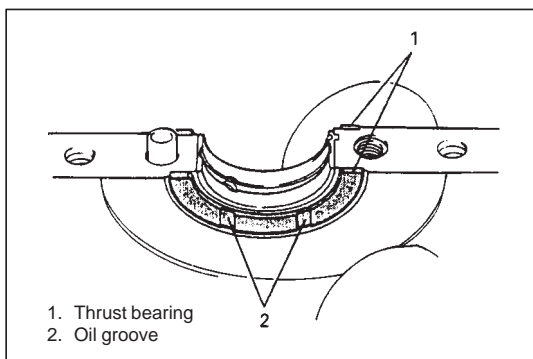

Item \ Thrust Bearing	Standard	Oversize 0.125 mm (0.0049 in.)
Thickness of crankshaft thrust bearing	2.500 mm (0.984 in.)	2.563 mm (0.1009 in.)

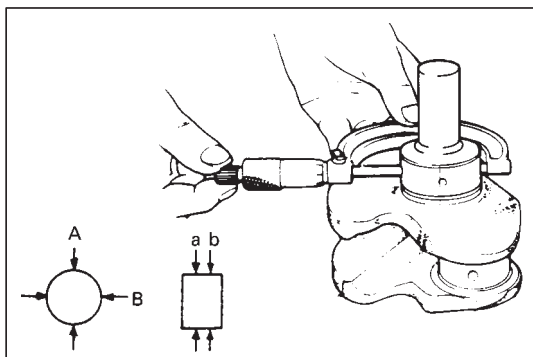

### Out-of-round and taper (uneven wear) of journals

An unevenly worn crankshaft journal shows up as a difference in diameter at a cross section or along its length (or both). This difference, if any, is determined by taking micrometer readings. If any one of journals is badly damaged or if amount of uneven wear in the sense explained above exceeds its limit, regrind or replace crankshaft.

**Limit on out-of-round and taper: 0.01 mm (0.0004 in.)**

**Out-of-round:  $A - B$**

**Taper:  $a - b$**

### Main Bearings

#### General information

- Service main bearings are available in standard size and 0.25 mm (0.0098 in.) undersize, and each of them has 5 kinds of bearings differing in tolerance.

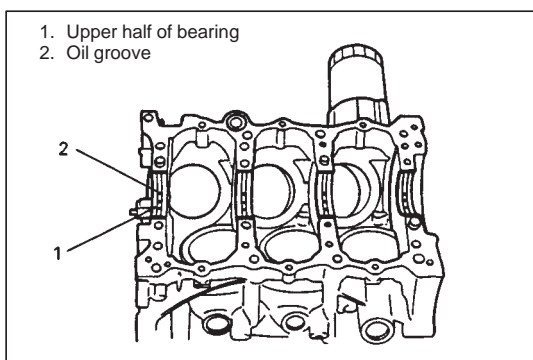

- Upper half of bearing has oil groove as shown in figure. Install this half with oil groove toward cylinder block.
- Lower half of bearing does not have oil groove.

## Inspect

Check bearings for pitting, scratches, wear or damage.

If any malcondition is found, replace both upper and lower halves. Never replace either half without replacing the other half.

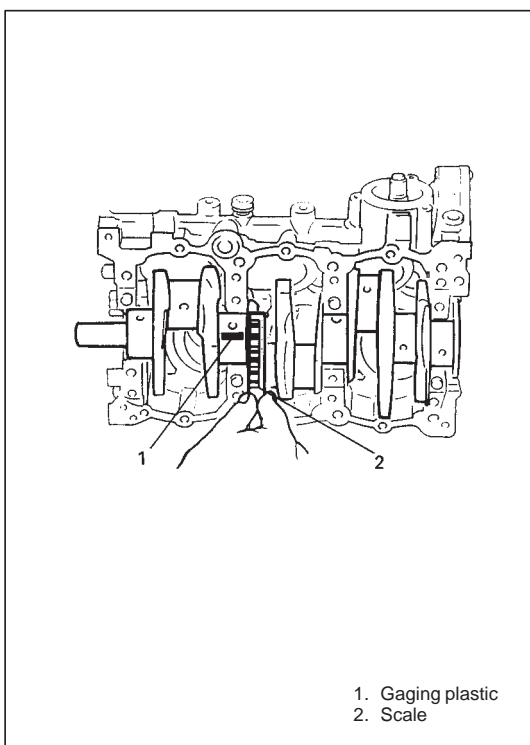
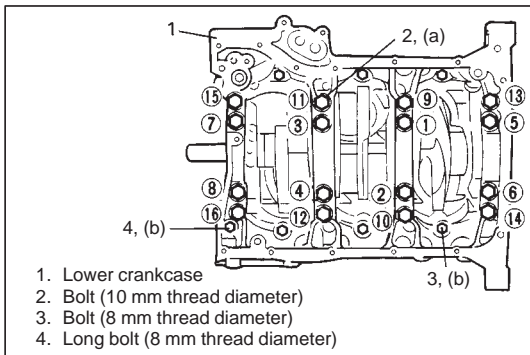
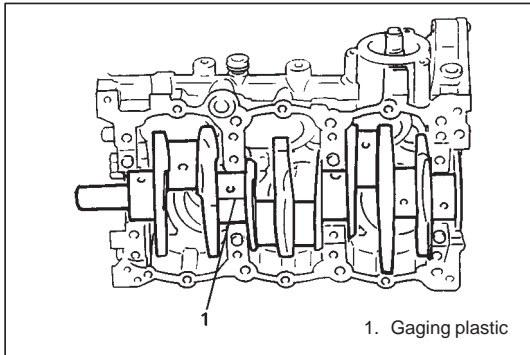

## Main bearing clearance

Check clearance by using gaging plastic according to following procedure.

- 1) Remove crankcase.
- 2) Clean bearings and main journals.
- 3) Place a piece of gaging plastic to full width of bearing (parallel to crankshaft) on journal, avoiding oil hole.
- 4) Install crankcase to cylinder block.  
Tighten crankcase bolts, following sequence in figure. Tighten crankcase bolts to specified torque.

### NOTE:

**Tighten 10 mm thread diameter bolts first (following the order shown in figure) then tighten 8 mm thread diameter bolts.**

### Tightening Torque

(a): 60 N·m (6.0 kg-m, 43.5 lb-ft)

(b): 27 N·m (2.7 kg-m, 19.5 lb-ft)

### NOTE:

**Do not rotate crankshaft while gaging plastic is installed.**

- 5) Remove crankcase and using scale on gaging plastic envelop, measure gaging plastic width at its widest point. If clearance exceeds its limit, replace bearing. Always replace both upper and lower inserts as a unit.

A new standard bearing may produce proper clearance. If not, it will be necessary to regrind crankshaft journal for use of 0.25 mm undersize bearing.

After selecting new bearing, recheck clearance.

## Bearing Clearance

**Standard: 0.026 – 0.046 mm (0.0010 – 0.0018 in.)**

**Limit: 0.060 mm (0.0023 in.)**

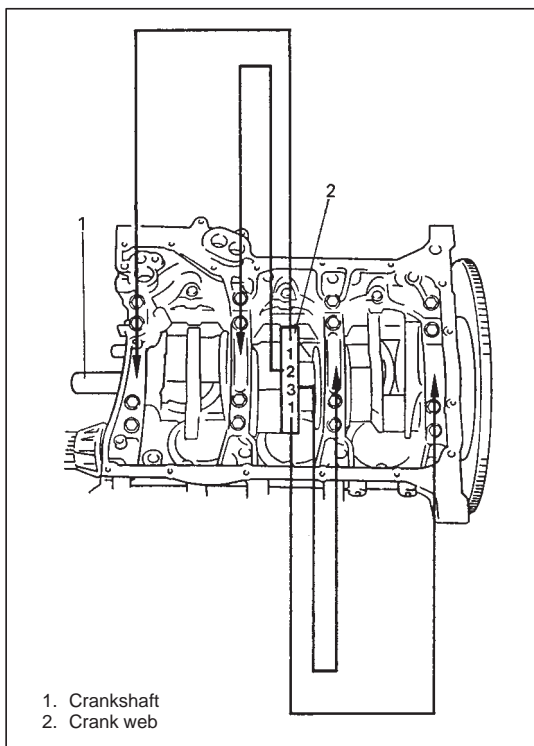

## Selection of main bearings

### STANDARD BEARING:

If bearing is in malcondition, or bearing clearance is out of specification, select a new standard bearing according to following procedure and install it.

- 1) First check journal diameter. As shown in figure, crank web has stamped numbers and alphabet at the center. Three kinds of numbers ("1", "2" and "3") represent following journal diameters.

Stamped numbers	Journal diameter
1	64.994 – 65.000 mm (2.5588 – 2.5590 in.)
2	64.988 – 64.994 mm (2.5586 – 2.5588 in.)
3	64.982 – 64.988 mm (2.5583 – 2.5586 in.)

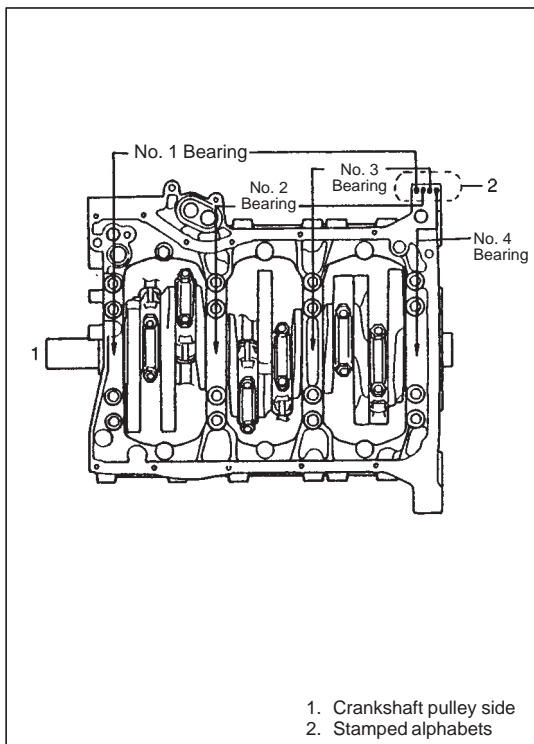

- 2) Next, check crankcase (bearing cap) bore diameter without bearing. On lower surface of lower crankcase 4 alphabets are stamped as shown in figure.

Three kinds of alphabets (A, B and C) represent following cap bore diameters.

Stamped alphabet	Bearing cap bore diameter (without bearing)
A	70.000 – 70.006 mm (2.7559 – 2.7561 in.)
B	70.006 – 70.012 mm (2.7561 – 2.7563 in.)
C	70.012 – 70.018 mm (2.7563 – 2.7566 in.)

- 3) There are five kinds of standard bearings differing in thickness. To distinguish them, they are painted in following colors at the position as indicated in figure. Each color indicates following thickness at the center of bearing.

Color painted	Bearing thickness
Green	2.493 – 2.497 mm (0.0982 – 0.0983 in.)
Black	2.496 – 2.500 mm (0.0983 – 0.0984 in.)
Colorless (no paint)	2.499 – 2.503 mm (0.0984 – 0.0985 in.)
Yellow	2.502 – 2.506 mm (0.0985 – 0.0986 in.)
Blue	2.505 – 2.509 mm (0.0986 – 0.0987 in.)

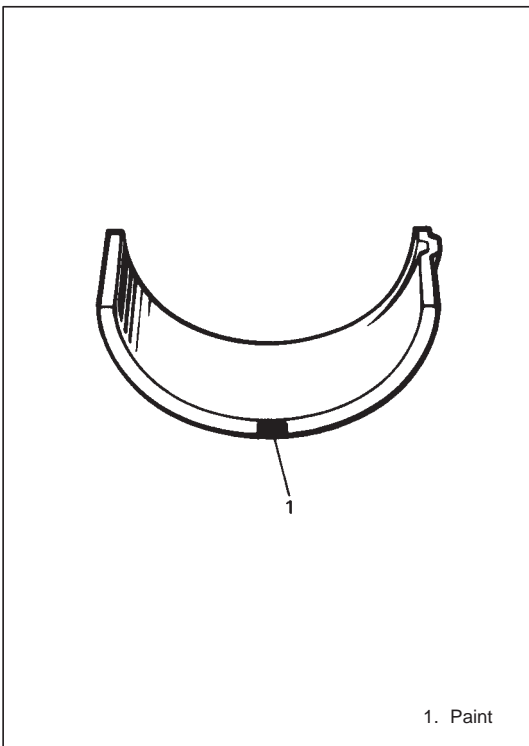

- 4) From number stamped on crank webs at its center and alphabets stamped on crankcase lower side, determine new standard bearing to be installed to journal, by referring to table shown below.

For example, if number stamped on crank webs is “1” and alphabet stamped on crankcase is “B”, install a new standard bearing painted in “Black” to its journal.

		Number stamped on crank web (Journal diameter)		
		1	2	3
Alphabet stamped on lower crankcase (Cap bore dia.)	A	Green	Black	Colorless
	B	Black	Colorless	Yellow
	C	Colorless	Yellow	Blue
		New standard bearing to be installed.		

- 5) Using gaging plastic, check bearing clearance with newly selected standard bearing. If clearance still exceeds its limit, use next thicker bearing and recheck clearance.
- 6) When replacing crankshaft or cylinder block and crank case due to any reason, select new standard bearings to be installed by referring to number stamped on new crankshaft or alphabets stamped on new crankcase lower side.

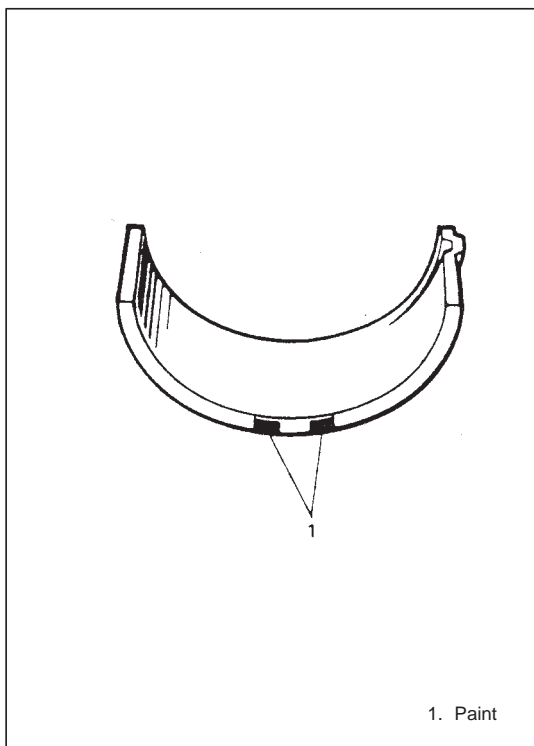
**UNDERSIZE BEARING (0.25 mm):**

- 0.25 mm undersize bearing is available, in five kinds varying in thickness.

To distinguish them, each bearing is painted in following colors at such position as indicated in figure.

Each color represents following thickness at the center of bearing.

Color painted	Bearing thickness
Green & Red	2.618 – 2.622 mm (0.1031 – 0.1032 in.)
Black & Red	2.621 – 2.625 mm (0.1032 – 0.1033 in.)
Red only	2.624 – 2.628 mm (0.1033 – 0.1034 in.)
Yellow & Red	2.627 – 2.631 mm (0.1034 – 0.1035 in.)
Blue & Red	2.630 – 2.634 mm (0.1035 – 0.1036 in.)

- If necessary, regrind crankshaft journal and select undersize bearing to use with it as follows.

1) Regrind journal to following finished diameter.

**Finished diameter: 64.732 – 64.750 mm  
(2.5485 – 2.5492 in.)**

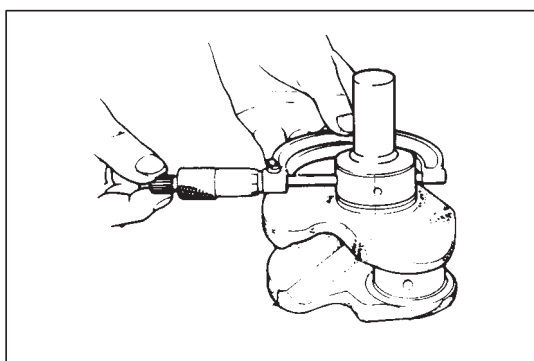

2) Using micrometer, measure reground journal diameter. Measurement should be taken in two directions perpendicular to each other in order to check for out-of-round.

3) Using journal diameter measured above and alphabets stamped on lower crankcase, select an undersize bearing by referring to table given below.

Check bearing clearance with newly selected undersize bearing.

		Measured journal diameter		
		64.744 – 64.750 mm (2.5489 – 2.5492 in.)	64.738 – 64.744 mm (2.5487 – 2.5489 in.)	64.732 – 64.738 mm (2.5485 – 2.5487 in.)
Alphabets stamped on lower crankcase	A	Green & Red	Black & Red	Red only
	B	Black & Red	Red only	Yellow & Red
	C	Red only	Yellow & Red	Blue & Red
Undersize bearing to be installed				

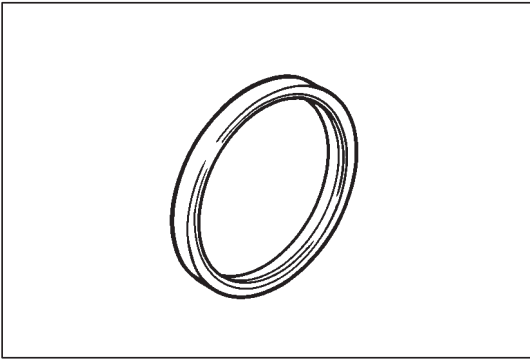

### Rear Oil Seal

Carefully inspect oil seal for wear or damage. If lip portion is worn or damaged, replace oil seal.

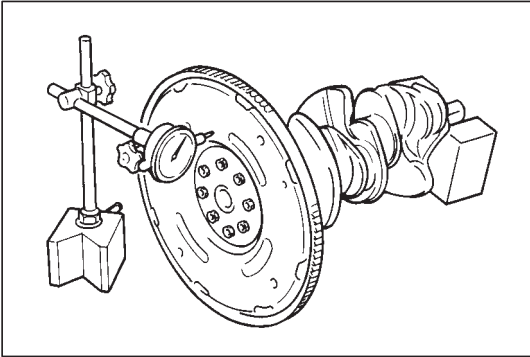

### Flywheel

- If ring gear is damaged, cracked or worn, replace flywheel.
- If the surface contacting clutch disc is damaged, or excessively worn, replace flywheel.
- Check flywheel for face runout with a dial gauge. If runout exceeds its limit, replace flywheel.

**Limit on runout: 0.2 mm (0.0078 in.)**

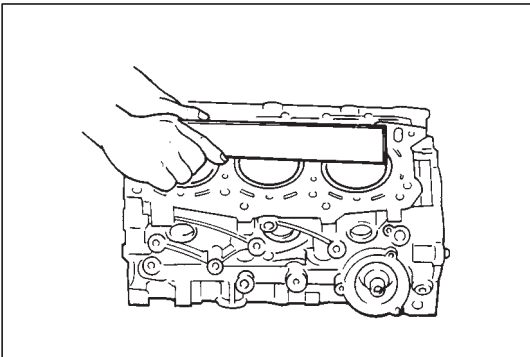

### Cylinder Block

#### Distortion of gasketed surface

- Using straightedge and thickness gauge, check gasketed surface for distortion and, if flatness exceeds its limit, correct it.

**Flatness Limit: 0.06 mm (0.0024 in.)**

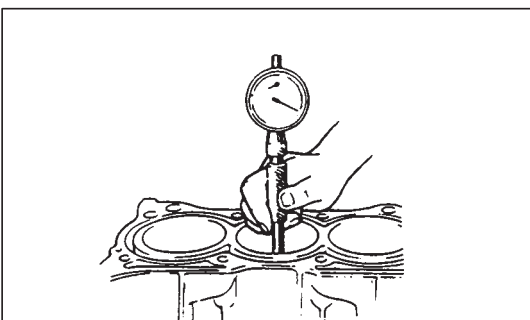

### Honing or reboring cylinders

- 1) When any cylinder needs reboring, all other cylinders must also be rebored at the same time.
- 2) Select oversized piston according to amount of cylinder wear.

Size	Piston diameter
STD	83.970 – 83.990 mm (3.3059 – 3.3067 in.)
O/S 0.25	84.220 – 84.240 mm (3.3157 – 3.3165 in.)
O/S 0.50	84.470 – 84.490 mm (3.3256 – 3.3264 in.)

- 3) Using micrometer, measure piston diameter.
- 4) Calculate cylinder bore diameter to be rebored as follows.

$$D = A + B - C$$

D: Cylinder bore diameter to be rebored

A: Piston diameter as measured

B: Piston clearance = 0.02 – 0.04 mm  
(0.0008 – 0.0015 in.)

C: Allowance for honing = 0.02 mm  
(0.0008 in.)

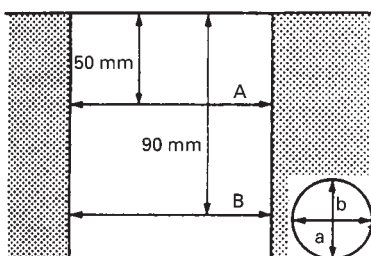

5) Rebore and hone cylinder to calculated dimension.

**NOTE:**

**Before reboring, install all main bearing caps in place and tighten to specification to avoid distortion of bearing bores.**

6) Measure piston clearance after honing.

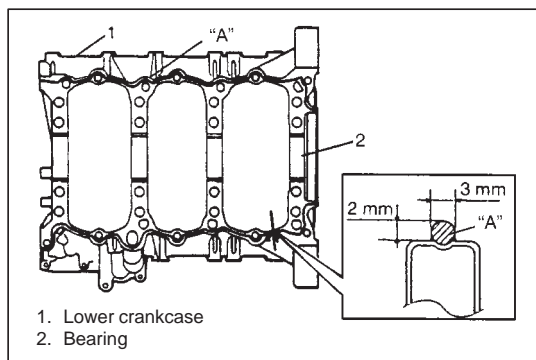
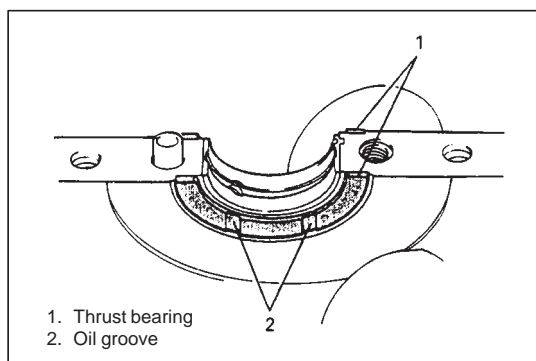
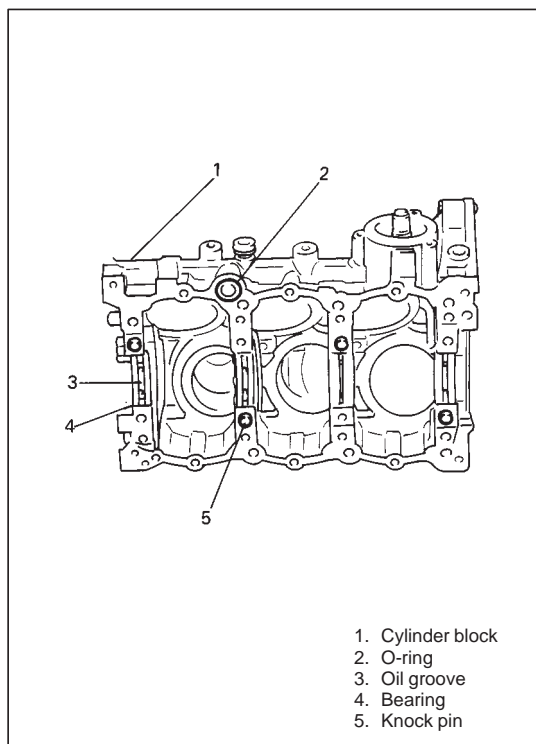

**INSTALLATION**

**NOTE:**

- All parts to be installed must be perfectly clean.
- Be sure to oil crankshaft journals, journal bearings, thrust bearings, crank pins, connecting rod bearings, pistons, piston rings and cylinder bores.
- Journal bearings, crankcase (bearings caps), connecting rods, rod bearings, rod bearing caps, pistons and piston rings are in combination sets. Do not disturb combination and try to see that each part goes back to where it came from, when installing.
- Clean mating surface of cylinder block and crankcase, remove oil, old sealant and dust from mating surface.

1) Fit main bearings to cylinder block.

One of two halves of main bearing, has oil groove. Install this half with oil groove to cylinder block, and another half without oil groove to crankcase.

Make sure that two halves are painted in the same color.

2) Install O-ring to cylinder block.

3) Fit thrust bearings to cylinder block between No.2 and No.3 cylinders. Face oil groove sides to crank webs.

4) Put crankshaft to cylinder block.

5) Apply sealant "A" to crankcase mating surface area as shown in figure.

**"A": Sealant 99000-31150**

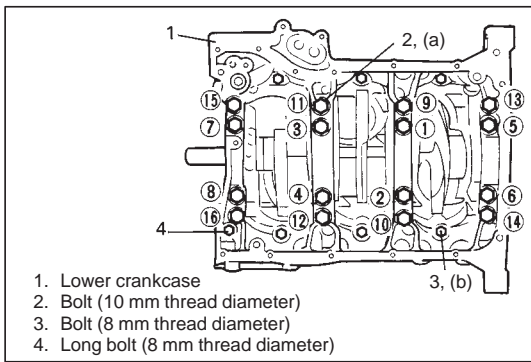

- 6) Install crankcase to cylinder block. Apply oil to crankcase bolts before installing them. Tighten crankcase bolts, following sequence in figure. Tighten crankcase bolts to specified torque.

**NOTE:**

**Tighten 10 mm thread diameter bolts first (following the order shown in figure), then tighten 8 mm thread diameter bolts.**

**Tightening Torque**

**(a): 60 N·m (6.0 kg-m, 43.5 lb-ft)**

**(b): 27 N·m (2.7 kg-m, 19.5 lb-ft)**

**NOTE:**

**After tightening crankcase bolts, check to be sure that crankshaft rotates smoothly when turned by hand.**

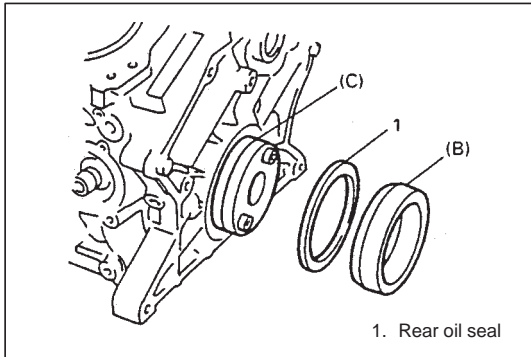

- 7) Using special tools (Oil seal installer and oil seal guide), install rear oil seal.

**Special Tool**

**(B): 09911-97810**

**(C): 09911-97710**

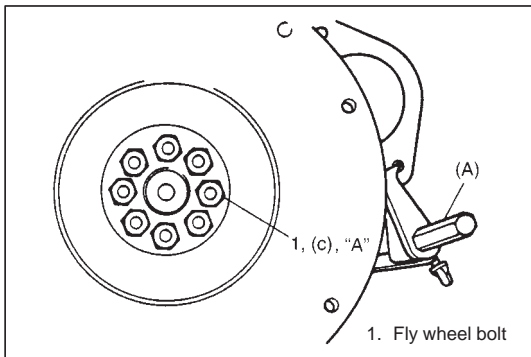

- 8) Install flywheel (M/T vehicle) or drive plate (A/T vehicle). Using special tool, lock flywheel or drive plate, and tighten flywheel or drive plate bolts applied with sealant to specification.

**“A”:** Sealant 1215 99000-31110

**Special Tool**



**(A): 09924-17810**



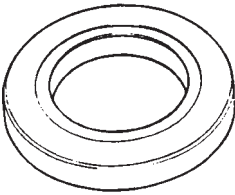
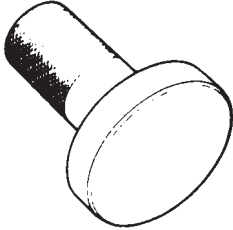
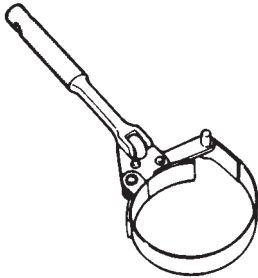
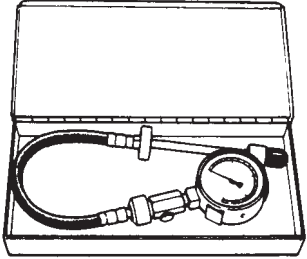
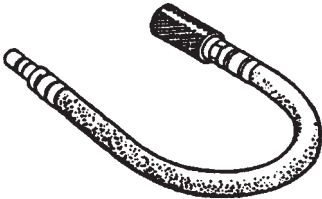
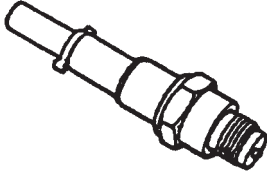
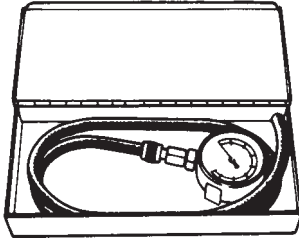
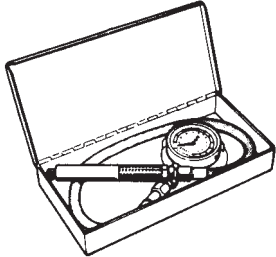
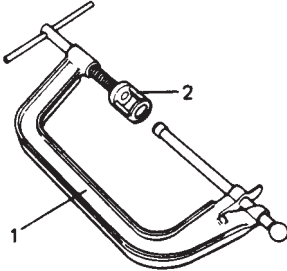
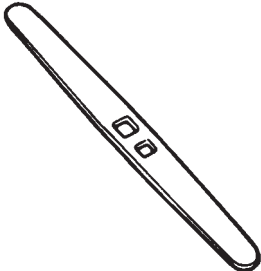
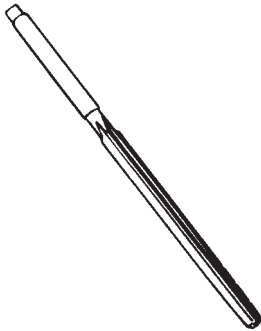
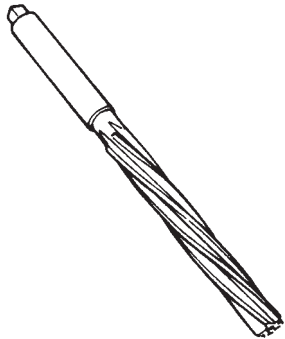
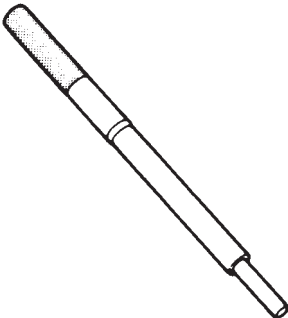
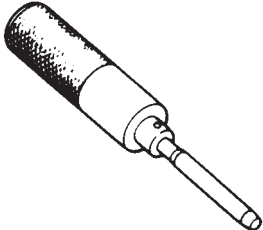
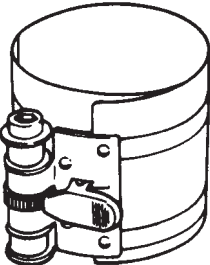

**Tightening Torque**

**(c): 70 N·m (7.0 kg-m, 50.5 lb-ft)**

- 9) Install oil pump, pistons and connecting rods as previously outlined.
- 10) Install oil pump strainer and oil pan.
- 11) Install cylinder heads assembly to cylinder block as previously outlined.
- 12) Install crankshaft oil pump sprocket, timing chain sprocket, oil pump chain, timing chain, timing chain cover, crankshaft pulley, water pump pulley, etc., as previously outlined.
- 13) Install clutch to flywheel (for M/T vehicle). For clutch installation, refer to Section 7C1.
- 14) Install engine assembly to vehicle as previously outlined.

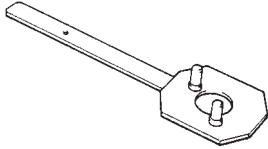
## SPECIAL TOOLS

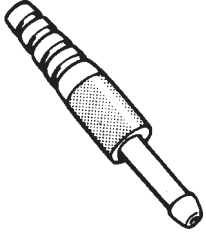
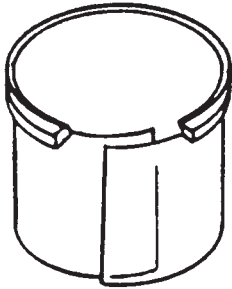
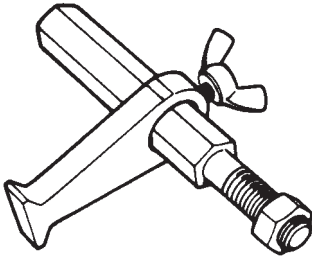
 <p>09911-97810 Oil seal installer</p>	 <p>09913-75510 Bearing installer</p>	 <p>09915-47310 Oil filter wrench</p>	 <p>09915-64510 Compression gauge</p>
 <p>09915-64530 Compression gauge hose</p>	 <p>09915-67010 Compression gauge attachment (c)</p>	 <p>09915-67310 Vacuum gauge</p>	 <p>09915-77310 Oil pressure gauge</p>
 <p>1. 09916-14510 Valve lifter 2. 09916-14910 Valve lifter attachment</p>	 <p>09916-34541 Reamer handle</p>	 <p>09916-37810 Reamer (6 mm)</p>	 <p>09916-38210 Reamer (11 mm)</p>
 <p>09916-44910 Valve guide remover</p>	 <p>09916-58210 Valve guide installer handle</p>	 <p>09916-77310 Piston ring compressor</p>	 <p>09916-84511 Forceps</p>

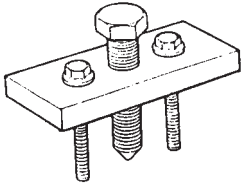
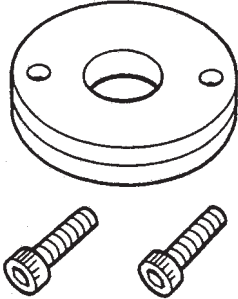
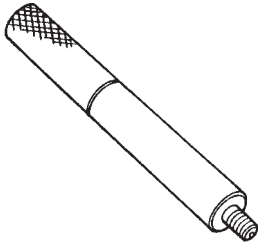
 <p>09917-68221 Camshaft lock holder</p>	 <p>09917-87810 Valve guide installer</p>	 <p>09917-98221 Valve stem seal installer</p>	 <p>09918-08210 Vacuum gauge hose joint</p>
 <p>09919-28610 Protective sleeve</p>	 <p>09924-17810 Flywheel holder</p>	 <p>09926-58010 Bearing puller attachment</p>	 <p>09944-36011 Steering wheel remover</p>
 <p>09911-97710 Oil seal guide</p>	 <p>09915-76510 Oil pressure gauge attachment</p>		

## REQUIRED SERVICE MATERIAL

RECOMMENDED SUZUKI PRODUCT	USE
<p>Sealant 1207C 99000-31150</p>	<ul style="list-style-type: none"> <li>● To apply to mating surfaces of cylinder block and oil pan.</li> <li>● To apply to mating surfaces of cylinder block and timing chain cover.</li> </ul>
<p>Sealant 1215 99000-31110</p>	<ul style="list-style-type: none"> <li>● To flywheel (M/T) or drive plate (A/T) bolts.</li> </ul>

# SECTION 6B

# ENGINE COOLING

## CONTENTS

<b>GENERAL DESCRIPTION</b> .....	6B- 2
Cooling System Circulation .....	6B- 2
Thermostat .....	6B- 4
Cooling Fan Clutch .....	6B- 4
Coolant .....	6B- 5
<b>DIAGNOSIS</b> .....	6B- 6
Diagnosis Table .....	6B- 6
<b>MAINTENANCE</b> .....	6B- 6
Coolant Level Check .....	6B- 6
Cooling System Service .....	6B- 7
Cooling System Flush and Refill .....	6B- 7
Cooling Fan Belt Tension Check and Adjustment .....	6B- 9
<b>ON-VEHICLE SERVICE</b> .....	6B-11
Coolant Draining .....	6B-11
Cooling Water Pipes or Hoses .....	6B-11
Thermostat .....	6B-13
Cooling Fan Belt .....	6B-15
Cooling Fan and Fan Clutch .....	6B-16
Radiator .....	6B-17
Water Pump .....	6B-19
Engine Coolant Temperature (ECT) Sensor .....	Refer to 6E1 (G16 and J20 engines) 6E2 (H25 engine)
<b>REQUIRED SERVICE MATERIAL</b> .....	6B-24
<b>TIGHTENING TORQUE SPECIFICATION</b> .....	6B-24

## GENERAL DESCRIPTION

The cooling system consists of the radiator cap, radiator, coolant reservoir, hoses, water pump, cooling fan, and thermostat. The radiator is of tube-and-fin type.

### WARNING:

- Do not remove radiator cap to check engine coolant level; check coolant visually at the see-through coolant reservoir.

Coolant should be added only to reservoir as necessary.

- As long as there is pressure in the cooling system, the temperature can be considerably higher than the boiling temperature of the solution in the radiator without causing the solution to boil. Removal of the radiator cap while engine is hot and pressure is high will cause the solution to boil instantaneously and possibly with explosive force, spewing the solution over engine, fenders and person removing cap. If the solution contains flammable anti-freeze such as alcohol (not recommended for use at any time), there is also the possibility of causing a serious fire.

## COOLING SYSTEM CIRCULATION

- While the engine is warmed up (thermostat closed), coolant circulates as follows.

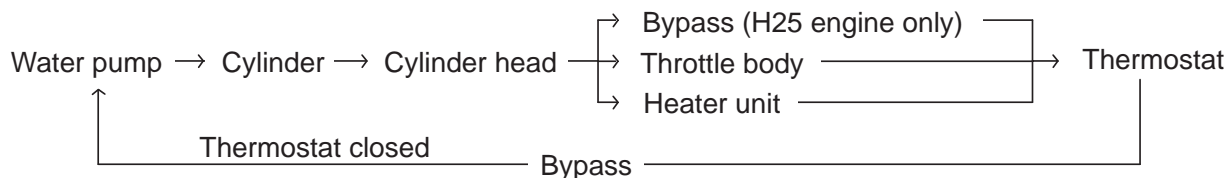

- When coolant is warmed up to normal temperature and the thermostat opens, coolant passes through the radiator core to be cooled as well as the above flow circuit.

[A]

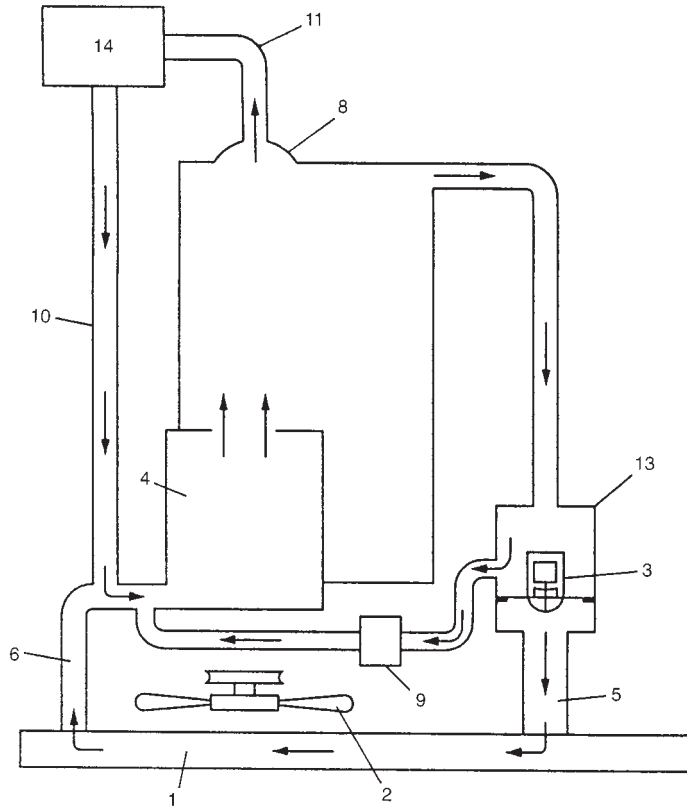

[A]: G16 engine  
 [B]: J20 engine  
 [C]: H25 engine

1. Radiator
2. Cooling fan
3. Thermostat
4. Water pump
5. Radiator inlet way
6. Radiator outlet way
7. Outlet pipe
8. Outlet cap
9. Throttle body
10. Heater outlet way
11. Heater inlet way
12. Bypass
13. Intake manifold
14. Heater unit

[B]

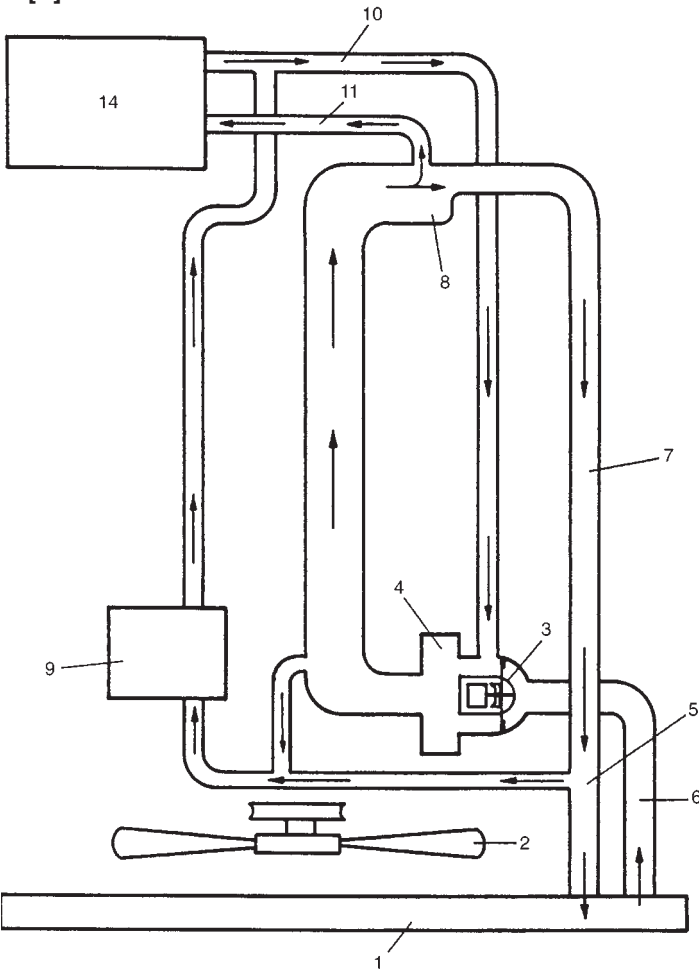

[C]

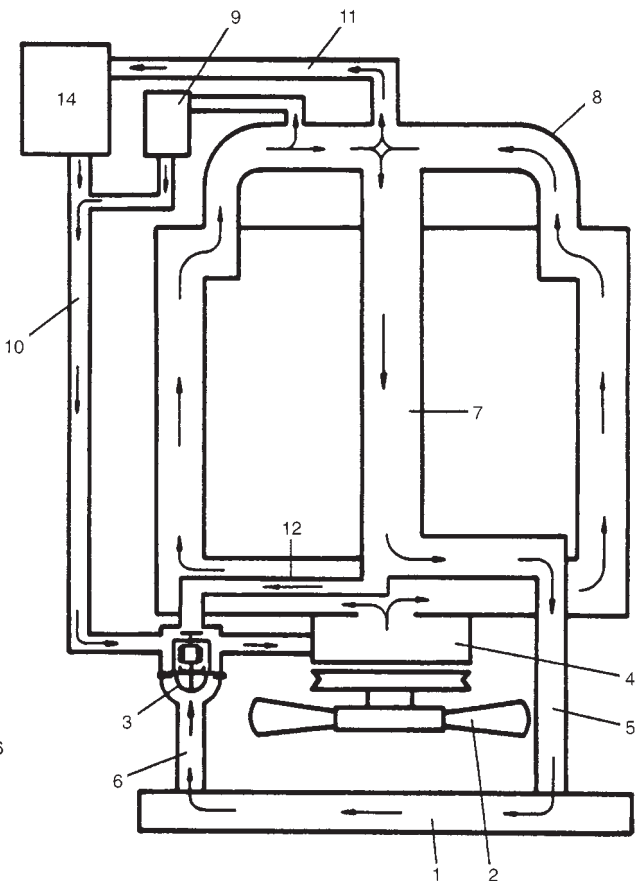

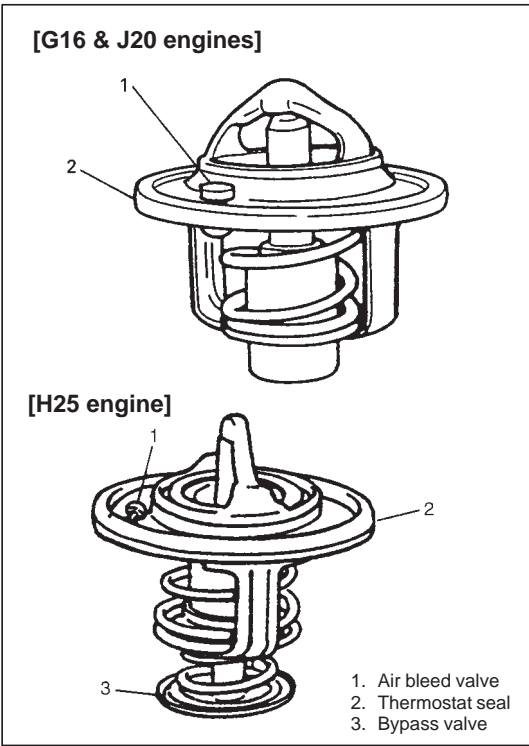

## THERMOSTAT

Temp. at which valve begins to open	J20 and H25 engines : $82 \pm 2^{\circ}\text{C}$ ( $179 \pm 3.6^{\circ}\text{F}$ ) G16 engine : $88 \pm 2^{\circ}\text{C}$ ( $190 \pm 3.6^{\circ}\text{F}$ )
Temp. at which valve becomes fully open	J20 and H25 engines : $95^{\circ}\text{C}$ ( $203^{\circ}\text{F}$ ) G16 engine : $100^{\circ}\text{C}$ ( $212^{\circ}\text{F}$ )
Valve lift	J20 and H25 engines : More than 8 mm at $95^{\circ}\text{C}$ ( $203^{\circ}\text{F}$ ) G16 engine : More than 8 mm at $100^{\circ}\text{C}$ ( $212^{\circ}\text{F}$ )

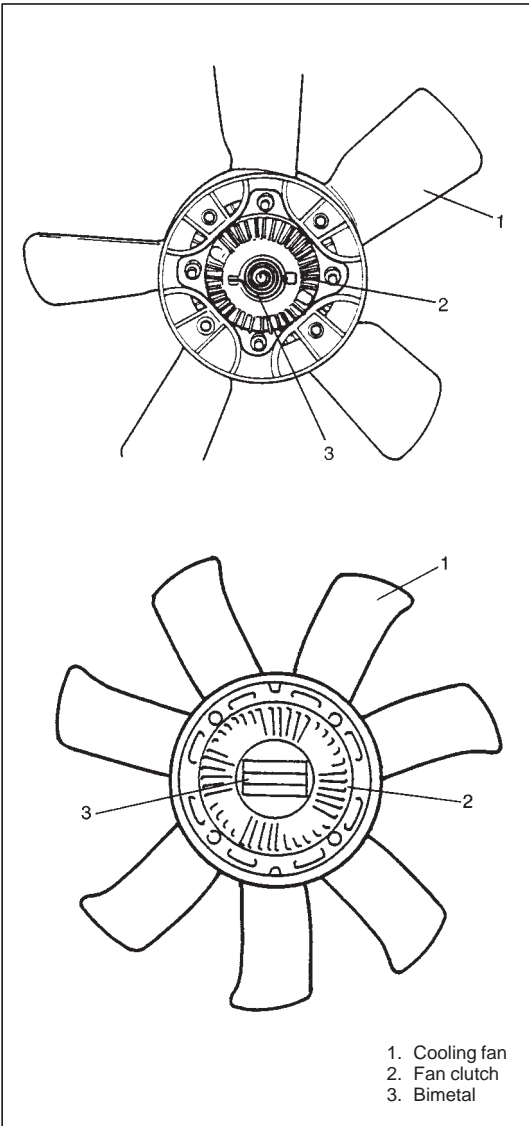

## COOLING FAN CLUTCH

Fluid is enclosed in the cooling fan clutch and at its center front, there is a bimetal whose thermal reaction and the engine speed control the cooling fan speed.

The relation between the temperature detected by the fan clutch and operation of the fan clutch is as follows.

While the fan clutch detects a temperature lower than  $50^{\circ}\text{C}$ , it remains OFF and the fan revolution speed is constant (400 to 900 r/min. (rpm) : J20 and H25 engines, 600 to 1,300 r/min.(rpm) : G16 engine) regardless of the engine speed. As the temperature reaches  $50^{\circ}\text{C}$  to  $70^{\circ}\text{C}$ , the fan clutch turns ON gradually and the fan revolution speed increases.

A temperature exceeding  $70^{\circ}\text{C}$  causes the fan clutch to turn ON and the fan revolution speed to increase in proportion with the engine speed.

Once the engine speed exceeds 4,000 r/min.(rpm), however, the fan revolution speed becomes constant (2,350 to 2,650 r/min.(rpm) : J20 and H25 engines, 2,800 to 3,100 r/min.(rpm) : G16 engine).

**CAUTION:**  
Do not disassemble fan clutch.

## COOLANT

The coolant recovery system is standard. The coolant in the radiator expands with heat, and the overflow is collected in the reservoir.

When the system cools down, the coolant is drawn back into the radiator.

The cooling system has been filled at the factory with a quality coolant that is a 50/50 mixture of water and ethylene glycol antifreeze.

This 50/50 mixture coolant solution provides freezing protection to  $-36^{\circ}\text{C}$  ( $-33^{\circ}\text{F}$ ).

◦ Maintain cooling system freeze protection at  $-36^{\circ}\text{C}$  ( $-33^{\circ}\text{F}$ ) to ensure protection against corrosion and loss of coolant from boiling.

This should be done even if freezing temperatures are not expected.

◦ Add ethylene glycol base coolant when coolant has to be added because of coolant loss or to provide added protection against freezing at temperature lower than  $-36^{\circ}\text{C}$  ( $-33^{\circ}\text{F}$ ).

### Anti-freeze proportioning chart:

Freezing temperature		$^{\circ}\text{C}$	-16	-36
		$^{\circ}\text{F}$	3	-33
Antifreeze/Anticorrosion coolant concentration		%	30	50
Ratio of compound to cooling water	G16 engine	ltr.	1.7/3.8	2.8/2.8
		US pt	3.5/8.1	5.8/5.8
		Imp. pt.	2.9/6.8	4.9/4.9
	J20 engine	ltr.	2.0/4.5	3.3/3.3
		US pt	4.1/9.6	6.9/6.9
		Imp. pt.	3.4/8.0	5.7/5.7
	H25 engine	ltr.	2.4/5.6	4.0/4.0
		US pt	5.1/11.8	8.5/8.5
		Imp. pt.	4.2/9.9	7.1/7.1

### Coolant capacity

		Engine, radiator and heater	Reservoir	Total
G16 engine	ltr. (US/Imp. pt.)	4.6 (9.7/8.1)	0.9 (1.9/1.6)	5.5 (11.6/9.7)
J20 engine	ltr. (US/Imp. pt.)	5.6 (11.8/9.1)	0.9 (1.9/1.6)	6.5 (13.7/11.4)
H25 engine	ltr. (US/Imp. pt.)	7.1 (15.0/12.5)	0.9 (1.9/1.6)	8.0 (16.9/14.1)

### NOTE:

- Alcohol or methanol base coolant or plain water alone should not be used in cooling system at any time as damage to cooling system could occur.
- Even in a market where no freezing temperature is anticipated, mixture of 70% water and 30% ethylene glycol antifreeze (Antifreeze/Anticorrosion coolant) should be used for the purpose of corrosion protection and lubrication.
- "Hard water", if used, will foul up the cooling circuit by scale formation. Tap water available from city water supply is the best available water, in a practical sense, for the cooling system. Distilled water is ideal but is a luxury in most cases.

## DIAGNOSIS

### DIAGNOSIS TABLE

Condition	Possible Cause	Correction
Engine overheats	<ul style="list-style-type: none"> <li>◦ Loose or broken water pump belt</li> <li>◦ Not enough coolant</li>   <li>◦ Faulty thermostat</li> <li>◦ Faulty water pump</li> <li>◦ Dirty or bent radiator fins</li> <li>◦ Coolant leakage on cooling system</li> <li>◦ Defective cooling fan clutch or thermo switch</li> <li>◦ Plugged radiator</li>   <li>◦ Faulty radiator cap</li> </ul>	<p>Adjust or replace. Check coolant level and add as necessary. Replace. Replace. Clean or remedy. Repair. Check and replace as necessary.</p> <p>Check and replace radiator as necessary. Replace.</p>

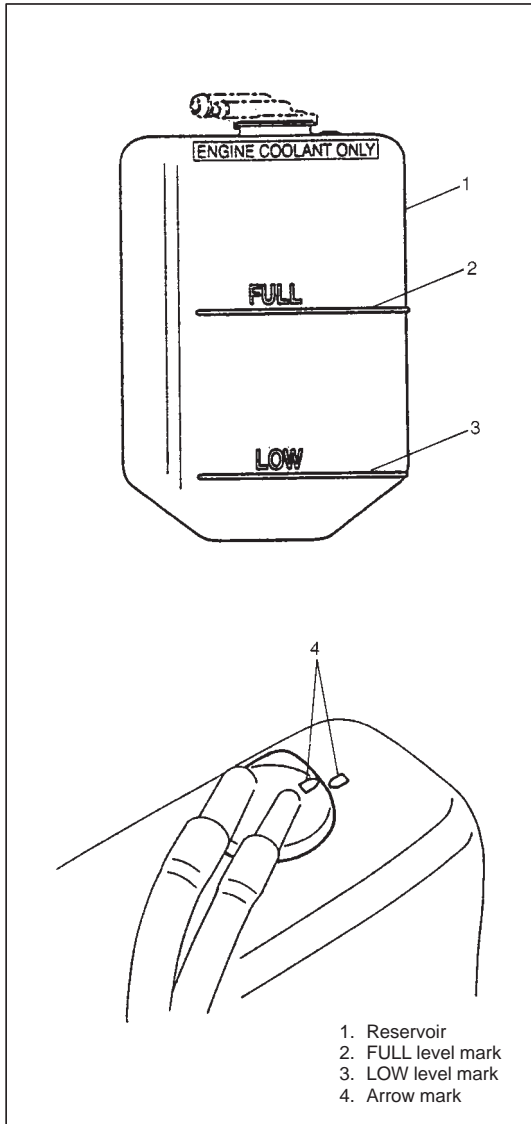

## MAINTENANCE

### COOLANT LEVEL CHECK

#### WARNING:

To help avoid danger of being burned:

- Do not remove reservoir cap while coolant is “boiling”, and
- Do not remove radiator cap while engine and radiator are still hot.

**Scalding fluid and steam can be blown out under pressure if either cap is taken off too soon.**

To check level, lift hood and look at “see-through” coolant reservoir. It is not necessary to remove radiator cap to check coolant level. When engine is cool, check coolant level in reservoir.

A normal coolant level should be between “FULL” and “LOW” marks on reservoir.

If coolant level is below “LOW” mark, remove reservoir cap and add proper coolant to reservoir to bring coolant level up to “FULL” mark. Then, reinstall cap.

#### NOTE:

- If recommended quality antifreeze is used, there is no need to add extra inhibitors or additives that claim to improve system.

**They may be harmful to proper operation of system.**

- When installing reservoir cap, align arrow marks on reservoir and cap.

## COOLING SYSTEM SERVICE

### WARNING:

To help avoid danger of being burned, do not remove radiator cap while engine and radiator are still hot.

Scalding fluid and steam can be blown out under pressure if cap is taken off too soon.

Cooling system should be serviced as follows.

- 1) Check cooling system for leakage or damage.
- 2) Wash radiator cap and filler neck with clean water by removing radiator cap when engine is cold.
- 3) Check coolant for proper level and freeze protection.
- 4) Using a pressure tester, check system and radiator cap for proper pressure holding capacity 110 kPa (1.1 kg/cm<sup>2</sup>, 15.6 psi). If replacement of cap is required, use proper cap specified for this vehicle.

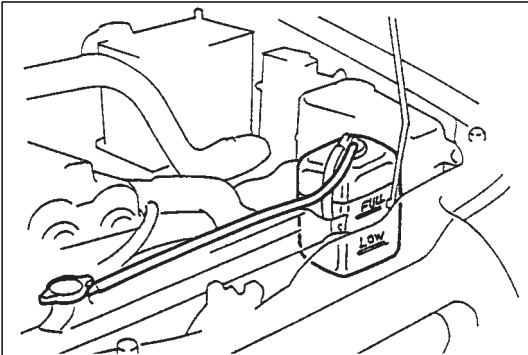

### NOTE:

After installing radiator cap to radiator, make sure that its ear is aligned with reservoir hose as shown in figure. If not, turn cap more to align its ear with hose.

- 5) Make sure that hose clamps are tightened securely and inspect all hoses.  
Replace hoses whenever cracked, swollen or otherwise deteriorated.
- 6) Clean frontal area of radiator core.

## COOLING SYSTEM FLUSH AND REFILL

- 1) Remove radiator cap when engine is cool.  
Turn cap slowly to the left until it reaches a “stop” (Do not press down while turning it).  
Wait until pressure is relieved (indicated by a hissing sound) then press down on cap and continue to turn it to the left.

### WARNING:

To help avoid danger of being burned, do not remove radiator cap while engine and radiator are still hot.

Scalding fluid and steam can be blown out under pressure if cap is taken off too soon.

- 2) With radiator cap removed, run engine until upper radiator hose is hot (this shows that thermostat is open and coolant is flowing through system).

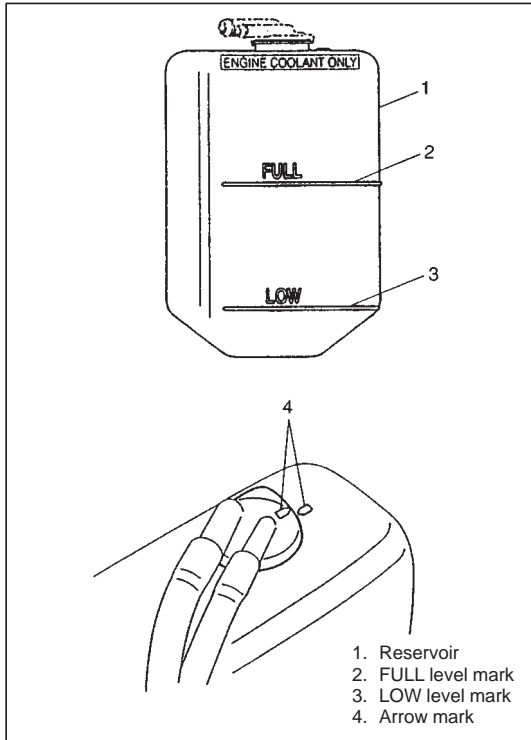
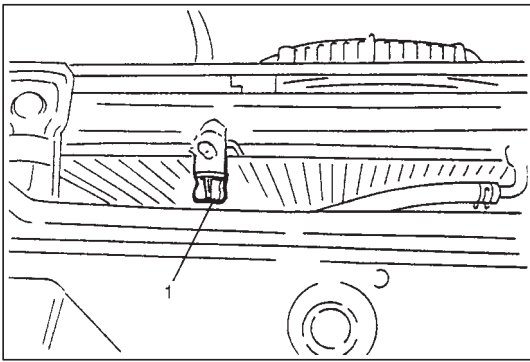

- 3) Stop engine and open radiator drain plug to drain coolant.
- 4) Close drain plug (1). Add water until system is filled and run engine until upper radiator hose is hot again.
- 5) Repeat steps 3) and 4) several times until drained liquid is nearly colorless.
- 6) Drain cooling system and then close radiator drain plug tightly.

- 7) Disconnect hose from reservoir. Remove reservoir and pour out any fluid. Scrub and clean inside of reservoir with soap and water. Flush it well with clean water and drain. Reinstall reservoir and hose.
- 8) Add 50/50 mixture of good quality ethylene glycol antifreeze and water to radiator and tank. Fill radiator to the base of radiator filler neck and reservoir to "FULL" level mark. Reinstall reservoir cap, aligning the arrow marks on the reservoir and cap.

- 9) Run engine, with radiator cap removed, until radiator upper hose is hot.
- 10) With engine idling, add coolant to radiator until level reaches the bottom of filler neck. Install radiator cap, making sure that the ear of cap lines up with reservoir hose.

[G16 engine]

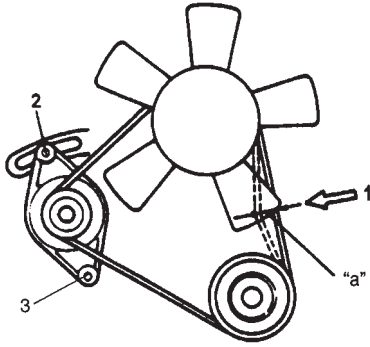

[H25 engine]

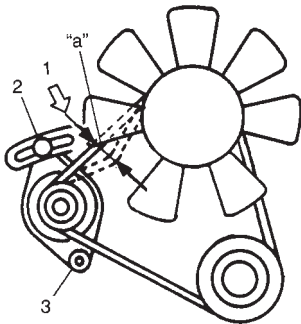

1. 10 kg (22 lbs)  
 2. Adjusting bolt  
 3. Pivot bolt  
 "a": Belt tension

## COOLING FAN BELT TENSION CHECK AND ADJUSTMENT

### WARNING:

Disconnect negative cable at battery before checking and adjusting belt tension.

### For G16 and H25 engines

- 1) Inspect belt for cracks, cuts, deformation, wear and cleanliness. If so, replace belt.
- 2) Check belt for tension. Belt is in proper tension when it deflects 6 to 8 mm (0.24 – 0.32 in.) under thumb pressure (about 10 kg or 22 lbs).

### Cooling fan belt tension "a" (as deflection/10 kg (22 lbs))

For G16 engine:

6 – 8 mm (0.24 – 0.32 in.)

For H25 engine:

9 – 11 mm (0.35 – 0.43 in.)

### NOTE:

When replacing belt with a new one, adjust belt tension to 5 – 7 mm (0.20 – 0.27 in.) (G16 engine) or 7 – 9 mm (0.27 – 0.35 in.) (H25 engine).

- 3) If belt is too tight or too loose, adjust it to proper tension by displacing generator position.
- 4) Tighten generator adjusting bolt and pivot bolt.
- 5) Connect negative (–) cable at battery.

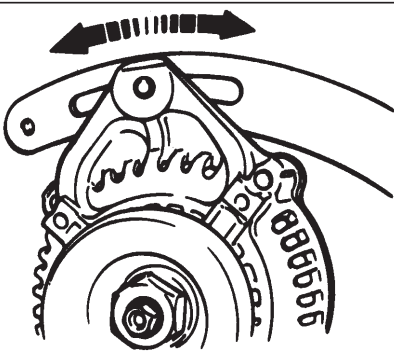

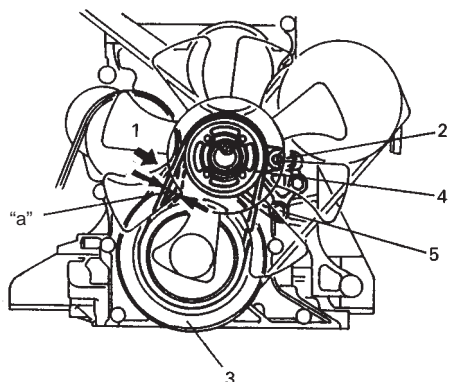
**[J20 engine]**

- |                      |                   |
|----------------------|-------------------|
| 1. 10 kg (22 lbs)    | 4. Fan pulley     |
| 2. Adjusting bolt    | 5. Pivot bolt     |
| 3. Crankshaft pulley | "a": Belt tension |

**For J20 engine**

- 1) Inspect belt for cracks, cuts, deformation, wear and cleanliness. If so, replace belt.
- 2) Check belt for tension. Belt is in proper tension when it deflects 5 to 7 mm (0.20 – 0.27 in.) under thumb pressure (about 10 kg or 22 lbs).

**Cooling fan belt tension "a" (as deflection/10 kg (22 lbs))****For J20 engine:**

5 – 7 mm (0.20 – 0.27 in.)

**NOTE:**

**When replacing belt with a new one, adjust belt tension to 4 – 5 mm (0.16 – 0.20 in.).**

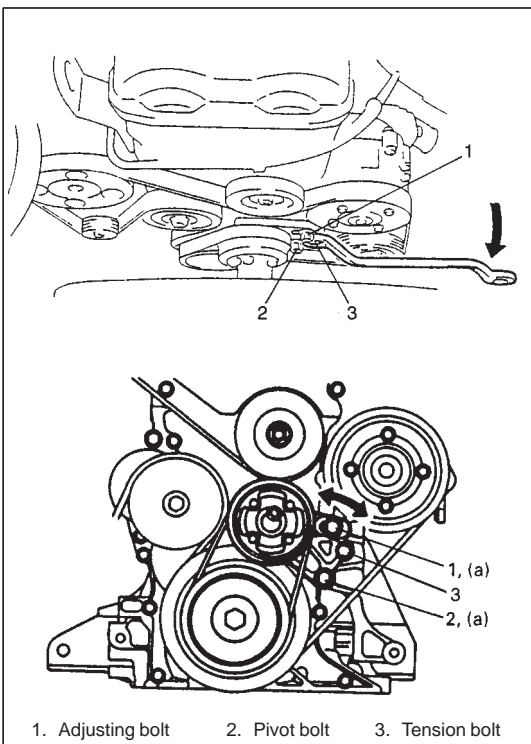

- |                   |               |                 |
|-------------------|---------------|-----------------|
| 1. Adjusting bolt | 2. Pivot bolt | 3. Tension bolt |
|-------------------|---------------|-----------------|

- 3) If belt is too tight or too loose, adjust it as follows:
  - a) Loosen adjusting bolt and pivot bolt.
  - b) Tighten adjusting bolt during keeping fan belt in proper tension by tightening tension bolt with wrench as shown in the figure.
  - c) Tighten adjusting bolt and pivot bolt to specified torque.

**Tightening torque****Cooling fan pulley adjusting bolt (for J20 engine) (a):**

45 N·m (4.5 kg-m, 32.5 lb-ft)

**Cooling fan pulley pivot bolt (for J20 engine) (a):**

45 N·m (4.5 kg-m, 32.5 lb-ft)

## ON-VEHICLE SERVICE

### WARNING:

- Check to make sure that engine coolant temperature is cold before removing any part of cooling system.
- Also be sure to disconnect negative cable from battery terminal before removing any part.

### COOLANT DRAINING

- 1) Remove radiator cap.
- 2) Loosen drain plug (1) on radiator to drain coolant.
- 3) After draining coolant, be sure to tighten drain plug securely.
- 4) Fill cooling system.

Refer to "COOLANT" and steps 8) to 10) of "COOLING SYSTEM FLUSH AND REFILL" in this section.

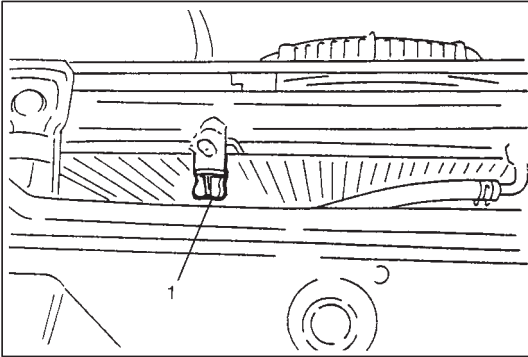

### COOLING WATER PIPES OR HOSES REMOVAL

#### For G16 and J20 engines

- 1) Disconnect negative (-) cable at battery.
- 2) Drain cooling system.
- 3) To remove these pipes or hoses, loosen screw on each pipe or hose clip and pull hose end off.

#### For H25 engine

- 1) Disconnect negative (-) cable at battery.
- 2) Drain cooling system.

- 3) Remove radiator inlet, outlet hoses (1), (2) and radiator outlet pipe (3).

- 4) Remove throttle body and intake manifold.  
Refer to Section 6A2 for removal.

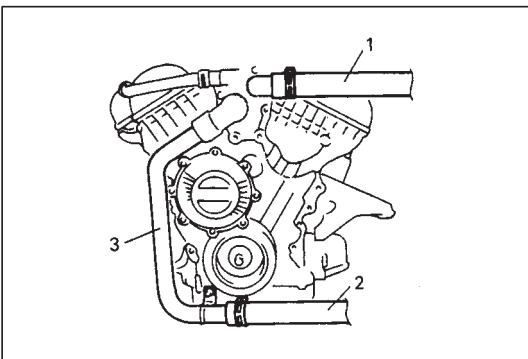

- 5) Disconnect ECT sensor (4) coupler.

- 6) Disconnect heater inlet hose (5) from water outlet cap (3).

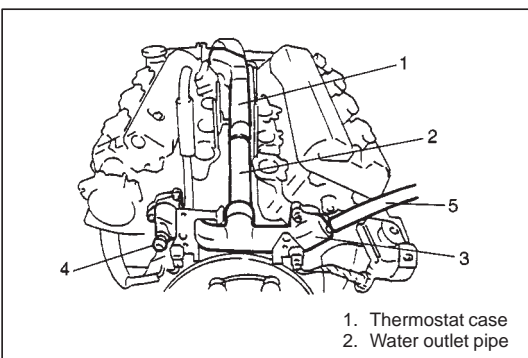

1. Thermostat case  
2. Water outlet pipe

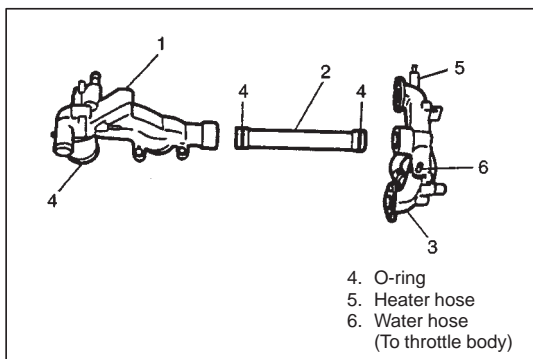

- 7) Remove water outlet cap (3) from cylinder heads.
- 8) Remove water outlet pipe (2) from thermostat case (1).
- 9) Remove thermostat case (1) from cylinder block.

## INSTALLATION

### For G16 and J20 engines

Install removed parts in reverse order of removal procedure, noting the following.

- Tighten each clamp bolt securely.

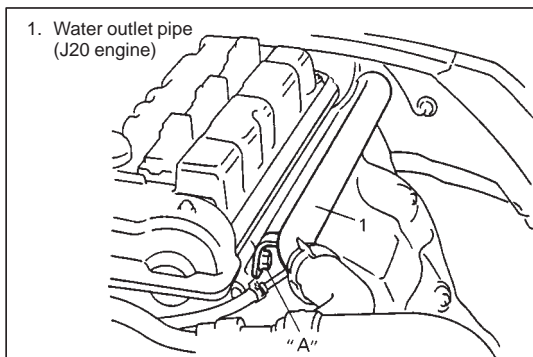

- When installing water outlet pipe to cylinder head, apply sealant to pipe bolt thread and then tighten it (J20 engine only).

### Sealant "A": 99000-31110

- Refill cooling system with proper coolant, referring to description on "COOLANT" and steps 8) to 10) of "COOLING SYSTEM FLUSH AND REFILL" in this section.
- Check each part for leakage.

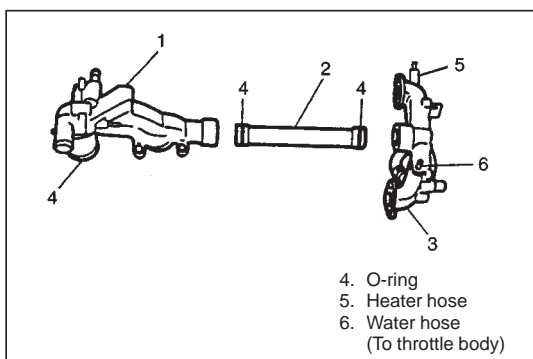

### For H25 engine

- 1) Install thermostat case (1) to cylinder block with new O-ring.
- 2) Install water outlet pipe (2) to thermostat case (1) with new O-rings.
- 3) Install water outlet cap (3) to cylinder heads with new gaskets.

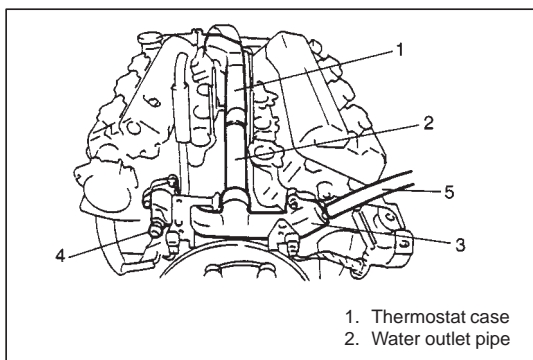

- 4) Connect heater inlet hose (5) to water outlet cap (3).
- 5) Connect ECT sensor (4) coupler.

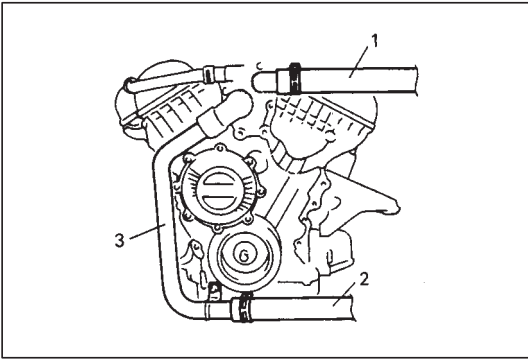

- 6) Install throttle body and intake manifold.  
Refer to Section 6A2 for installation.
- 7) Install radiator outlet pipe (3) to thermostat case with new O-ring.
- 8) Install radiator inlet and outlet hoses (1), (2).
- 9) Refill cooling system with proper coolant, referring to description on "COOLANT" and steps 8) to 10) of "COOLING SYSTEM FLUSH AND REFILL" in this section.

## THERMOSTAT

### REMOVAL

- 1) Drain cooling system and tighten drain plug.
- 2) Remove fan shroud with cooling fan after disconnecting radiator inlet hose from radiator (H25 engine only).
- 3) Remove thermostat cap (1).
- 4) Remove thermostat.

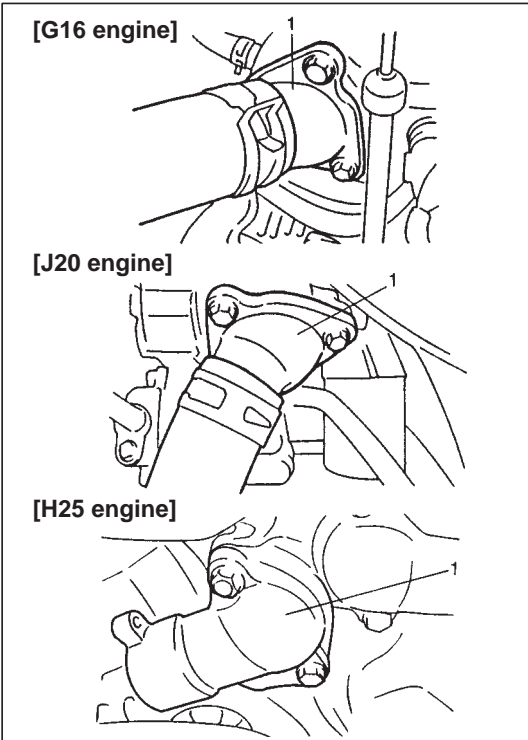

### INSPECTION

- Make sure that air bleed valve (1) of thermostat is clean. Should this valve be clogged, engine would tend to overheat.
- Check to make sure that valve seat is free from foreign matters which would prevent valve from seating tight.
- Check thermostat seal (2) and O-ring for breakage, deterioration or any other damage.

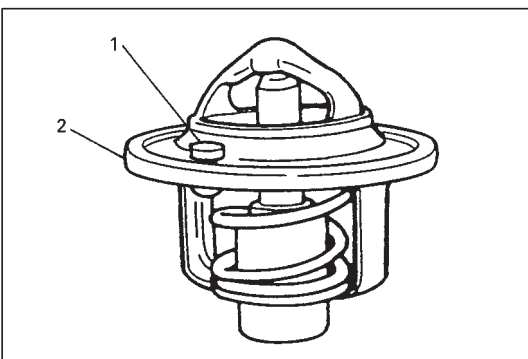

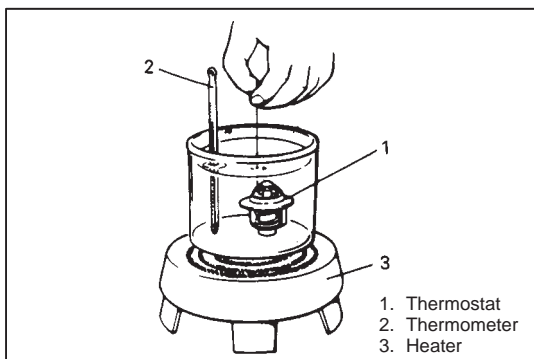

- Check thermostatic movement of wax pellet as follows:
  - a) Immerse thermostat in water, and heat water gradually.
  - b) Check that valve starts to open at specific temperature.
 If valve starts to open at a temperature substantially below or above specific temperature, thermostat unit should be replaced with a new one. Such a unit, if reused, will bring about overcooling or overheating tendency.

Temp. at which valve begins to open	J20 and H25 engines : $82 \pm 2^{\circ}\text{C}$ ( $179 \pm 3.6^{\circ}\text{F}$ ) G16 engine : $88 \pm 2^{\circ}\text{C}$ ( $190 \pm 3.6^{\circ}\text{F}$ )
Temp. at which valve becomes fully open	J20 and H25 engines : $95^{\circ}\text{C}$ ( $203^{\circ}\text{F}$ ) G16 engine : $100^{\circ}\text{C}$ ( $212^{\circ}\text{F}$ )
Valve lift	J20 and H25 engines : More than 8 mm at $95^{\circ}\text{C}$ ( $203^{\circ}\text{F}$ ) G16 engine : More than 8 mm at $100^{\circ}\text{C}$ ( $212^{\circ}\text{F}$ )

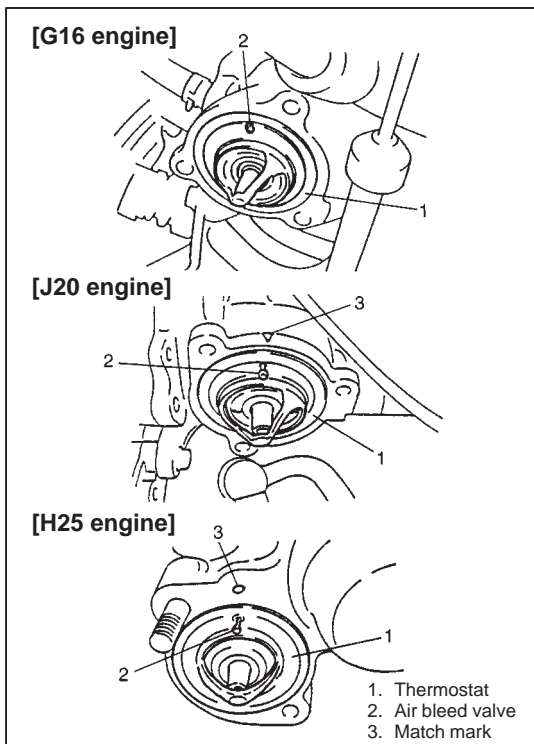

## INSTALLATION

- 1) When positioning thermostat and O-ring on thermostat case, be sure to position it so that
  - air bleed valve comes at top (G16 engine).
  - air bleed valve comes at match mark and into the recession of thermostat case (J20 and H25 engines).
- 2) Install thermostat cap to intake manifold (G16 engine), water pump (J20 engine) or thermostat case (H25 engine).
- 3) Install cooling fan and fan shroud and connect radiator inlet hose to radiator (H25 engine only).
- 4) Fill cooling system. Refer to "COOLANT" and steps 8) to 10) of "COOLING SYSTEM FLUSH AND REFILL" in this section.
- 5) Connect negative (-) cable at battery.
- 6) After installation, check each part for leakage.

## COOLING FAN BELT

### REMOVAL

#### For G16 and H25 engines

- 1) Disconnect negative (-) cable at battery.
- 2) Loosen P/S pump drive belt adjusting bolt and then remove P/S pump belt.

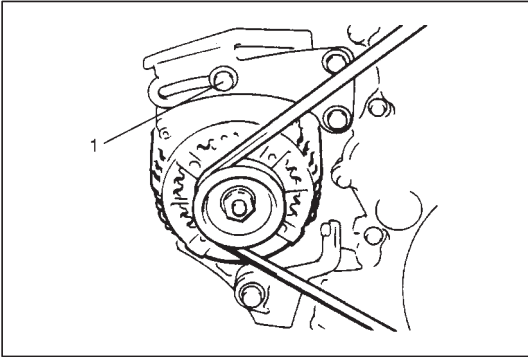

- 3) Loosen adjusting bolt (1) and pivot bolt.
- 4) Slacken belt by displacing generator and then remove it.

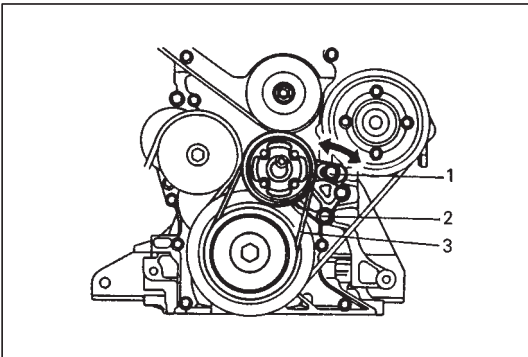

#### For J20 engine

- 1) Disconnect negative (-) cable at battery.
- 2) Loosen adjusting bolt (1) and pivot bolt (2).
- 3) Slacken belt by displacing fan pulley.
- 4) Remove cooling fan. Just detach the fan/clutch from fan pulley.
- 5) Remove cooling fan belt (3).

### INSTALLATION

#### For G16 and H25 engines

- 1) Install belt to water pump pulley, crankshaft pulley and generator pulley. Install P/S pump drive belt.
- 2) Adjust belt tension as specified.  
For Adjustment of P/S pump drive belt tension, refer to Section 0B.
- 3) Tighten adjusting bolt and pivot bolt.
- 4) Connect negative (-) cable at battery.

#### For J20 engine

- 1) Install belt to fan pulley and crankshaft pulley.
- 2) Install cooling fan. Refer to "COOLING FAN AND FAN CLUTCH" in this section.
- 3) Adjust belt tension as specified. Refer to "COOLING FAN BELT TENSION CHECK AND ADJUSTMENT" in this section.
- 4) Tighten adjusting bolt and pivot bolt.
- 5) Connect negative (-) cable at battery.

**COOLING FAN BELT TENSION INSPECTION**

Inspect belt and check belt tension. Refer to "COOLING FAN BELT TENSION CHECK AND ADJUSTMENT" in this section.

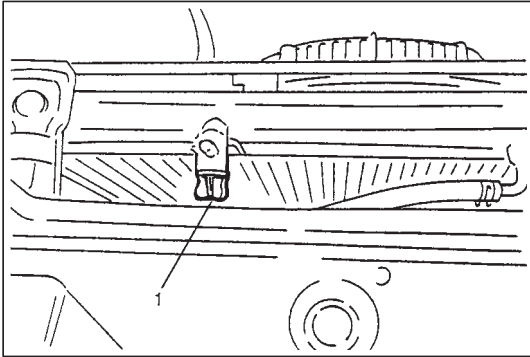
**COOLING FAN AND FAN CLUTCH****REMOVAL**

- 1) Disconnect negative (-) cable at battery.
- 2) Drain cooling system by loosening drain plug (1) of radiator.
- 3) Disconnect radiator inlet hose from radiator.
- 4) Loosen cooling fan/clutch nuts.
- 5) Remove P/S oil tank stay bolts (1) from radiator stay (G16 and H25 engines only).
- 6) Remove radiator shroud securing clips.
- 7) Then remove cooling fan/clutch and radiator shroud.

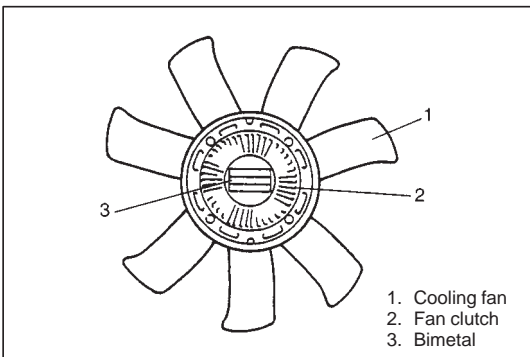
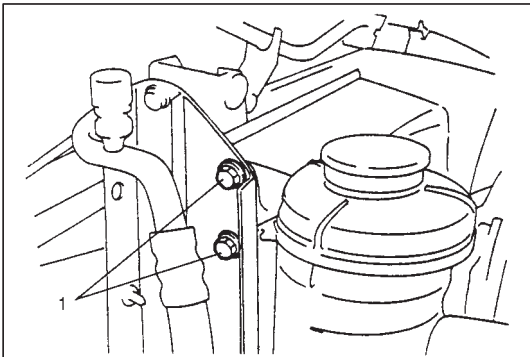
**INSPECTION**

Inspect fluid coupling for oil leakage.

If necessary, replace fan clutch assembly. Do not disassemble clutch assembly.

**INSTALLATION**

Install removed parts in reverse order of removal procedure.

- After installation, adjust belt tension for specification and tighten each bolt and nut securely.

**Tightening Torque**

**Cooling fan/dutch nut (G16 engine) (a):**

**11 N·m (1.1 kg-m, 8.0 lb-ft)**

**Cooling fan/dutch nut (H25 and J20 engines) (a):**

**25 N·m (2.5 kg-m, 18.0 lb-ft)**

- Refill cooling system with proper coolant referring to "COOLANT" and steps 8) to 10) of "COOLING SYSTEM FLUSH AND REFILL" in this section.
- After installation, check each joint for leakage.

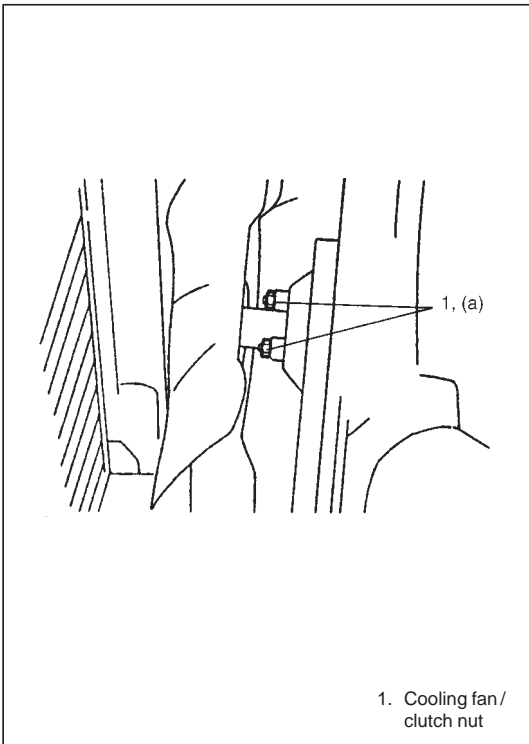
**RADIATOR****REMOVAL**

- 1) Disconnect negative (-) cable at battery.
- 2) Drain cooling system by loosening drain plug (1) of radiator.
- 3) When servicing A/T vehicle, place oil pan under radiator (1) and disconnect A/T fluid hoses (2), (3) from radiator.
- 4) Loosen cooling fan/clutch nuts (1).
- 5) Disconnect radiator inlet hose from radiator.

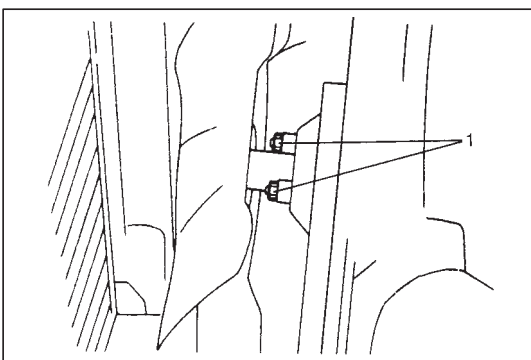
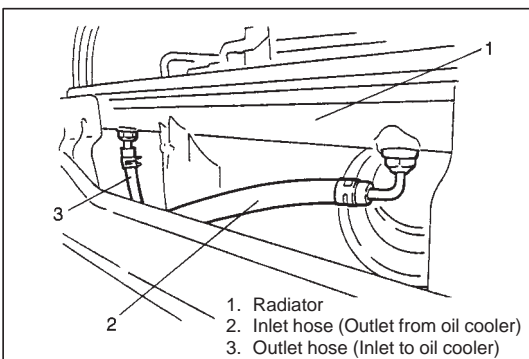
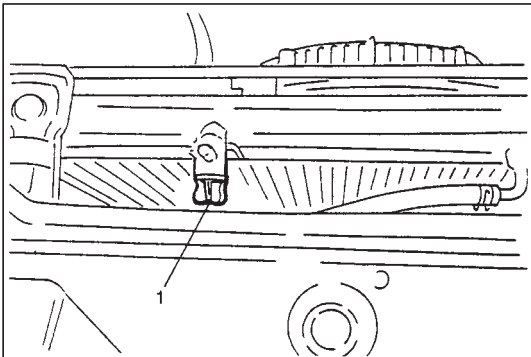

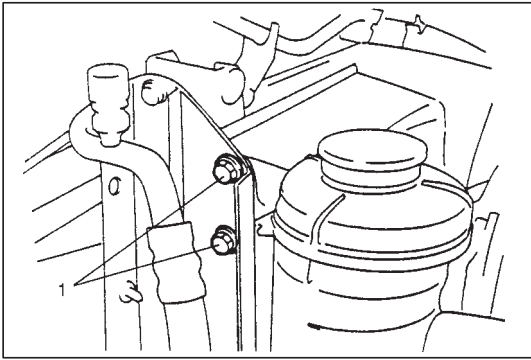

- 6) Remove P/S oil tank stay bolts (1) from radiator stay.
- 7) Remove radiator shroud securing clips.
- 8) Then remove cooling fan/clutch and radiator shroud.

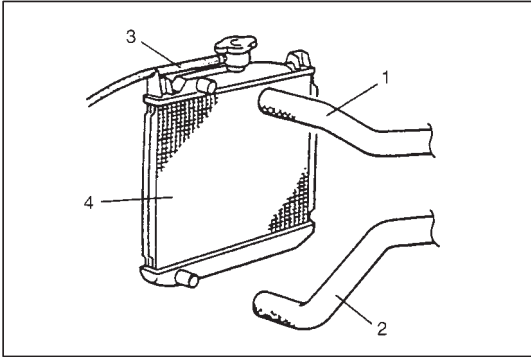

- 9) Disconnect water inlet and outlet hose (1), (2) and reservoir tank hose (3) from radiator.
- 10) Remove radiator (4).

### INSPECTION

Check radiator for leakage or damage. Straighten bent fins, if any.

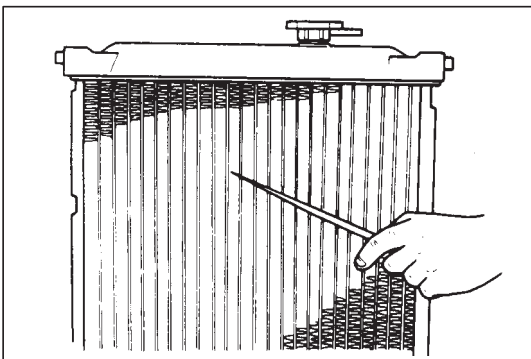

### CLEAN

Clean frontal area of radiator cores.

### INSTALLATION

Reverse removal procedures, noting the followings.

- Refill cooling system with proper coolant referring to "COOLANT" and steps 8) to 10) of "COOLING SYSTEM FLUSH AND REFILL" in this section.
- Adjust cooling fan belt tension to specification. Refer to "COOLING FAN BELT TENSION CHECK AND ADJUSTMENT" in this section.
- With A/T vehicle, check A/T fluid level, referring to Section 7B1.
- After installation, check each joint for leakage.

## WATER PUMP

### REMOVAL

#### For G16 engine

- 1) Disconnect negative (-) cable at battery.
- 2) Drain cooling system.
- 3) Remove timing belt and tensioner referring to "TIMING BELT AND BELT TENSIONER" in Section 6A1.
- 4) Remove rubber seal (1) between oil pump and water pump.

- 5) Remove oil level gauge guide (1) with oil level gauge.

- 6) Remove generator adjusting arm (1).

- 7) Remove water pump assembly (1).

#### CAUTION:

**Do not disassemble water pump.**

**If any repair is required on pump, replace it as assembly.**

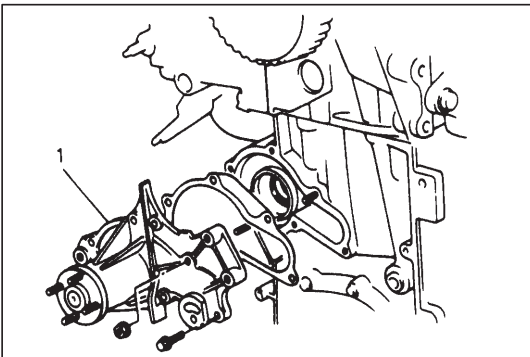
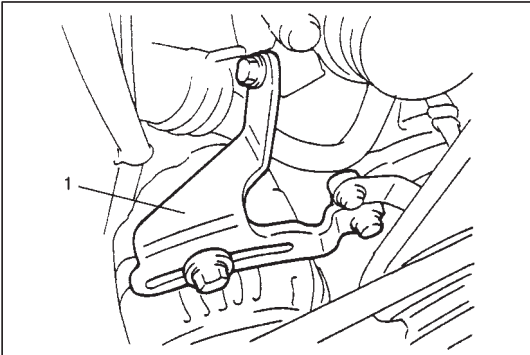
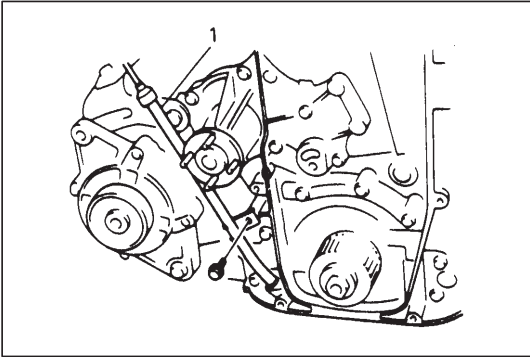
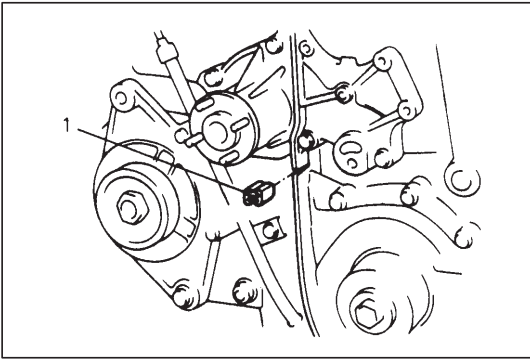

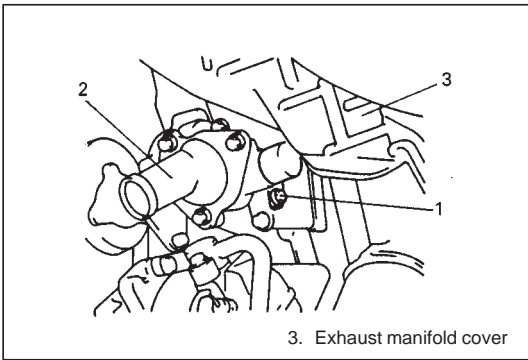
**For J20 engine**

- 1) Disconnect negative (-) cable at battery.
- 2) Drain coolant.
- 3) Remove radiator outlet hose from thermostat cap (2).
- 4) Remove heater outlet pipe bolt (1).
- 5) Remove generator belt by loosening tensioner pulley.  
Refer to Section 6H.

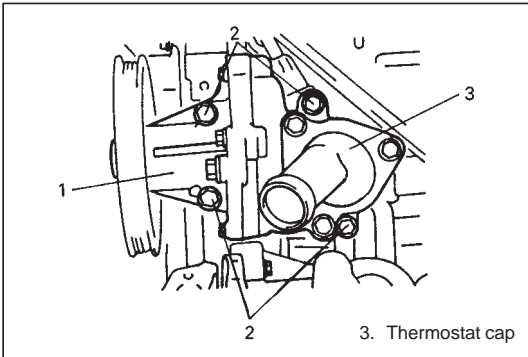

- 6) Remove water pump assembly (1) by removing its 4 bolts (2).

**NOTE:**

**Do not lose dowel pin when removing water pump (1).**

**For H25 engine**

- 1) Disconnect negative (-) cable at battery.
- 2) Drain engine oil.
- 3) Drain cooling system.
- 4) Remove timing chain cover. Refer to Section 6A2.

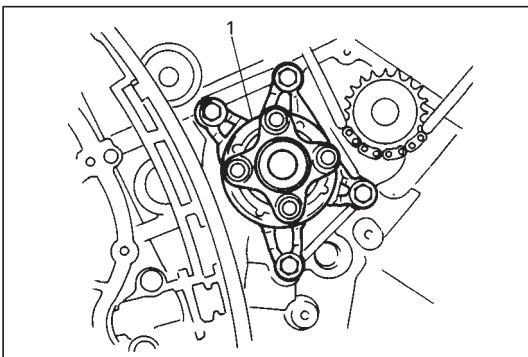

**INSPECTION****For G16 engine**

Rotate water pump by hand to check for smooth operation. If pump does not rotate smoothly or makes abnormal noise, replace it.

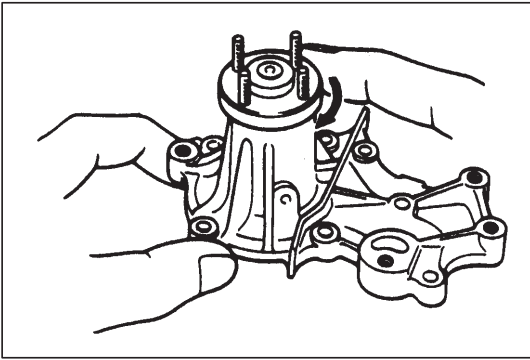
**For J20 engine****CAUTION:**

**Do not disassemble water pump.**

**If any repair is required on pump, replace it as assembly.**

◦ Rotate water pump by hand to check for smooth operation. If pump does not rotate smoothly or makes abnormal noise, replace it.

◦ Inspect water pump impeller for damage. Replace as necessary.

**CAUTION:**

**Do not disassemble water pump to check the water pump impeller.**

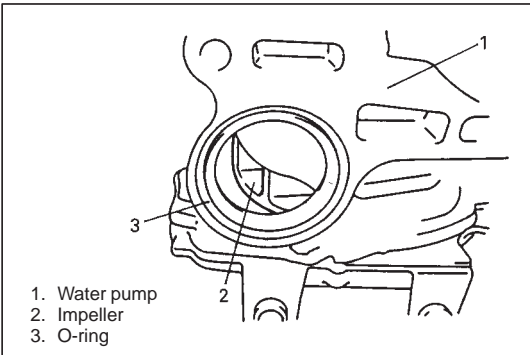
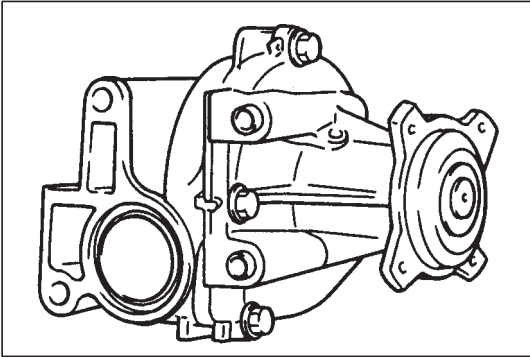
**For H25 engine****CAUTION:**

**Do not disassemble water pump.**

**If any repair is required on pump, replace it as assembly.**

◦ Rotate water pump by hand to check for smooth operation. If pump does not rotate smoothly or makes abnormal noise, replace it.

◦ Inspect water pump impeller for damage. Replace as necessary.

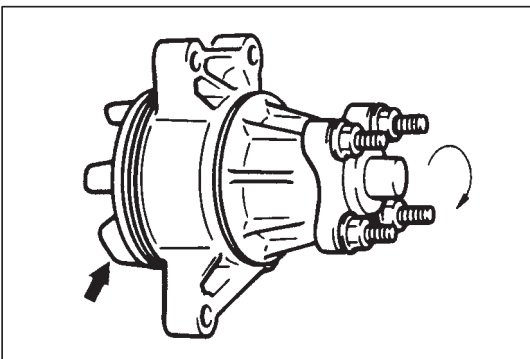

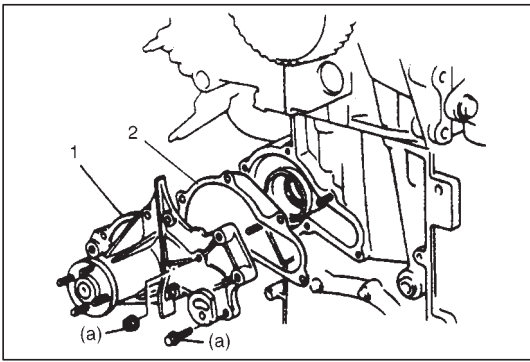

## INSTALLATION

### For G16 engine

- 1) Install new pump gasket (2) to cylinder block.
- 2) Install water pump (1) to cylinder block.

#### Tightening Torque

**Water pump bolt (G16 engine) (a): 12 N·m (1.2 kg-m, 8.5 lb-ft)**

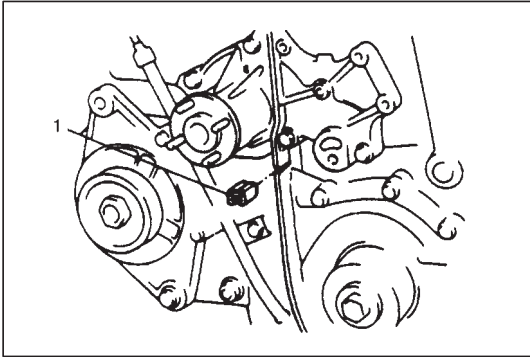

- 3) After installing water pump, install rubber seal (1) between water pump and oil pump.
- 4) Install belt tensioner, timing belt and timing belt outside cover referring to "TIMING BELT AND BELT TENSIONER" in Section 6A1.

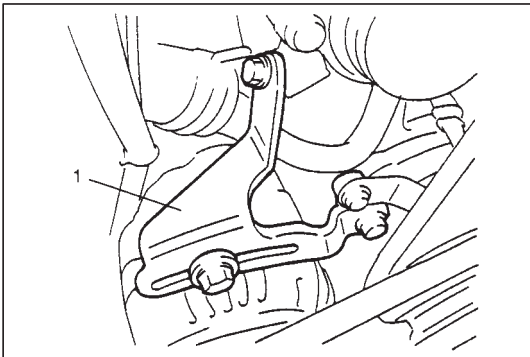

- 5) Install generator adjusting arm (1).

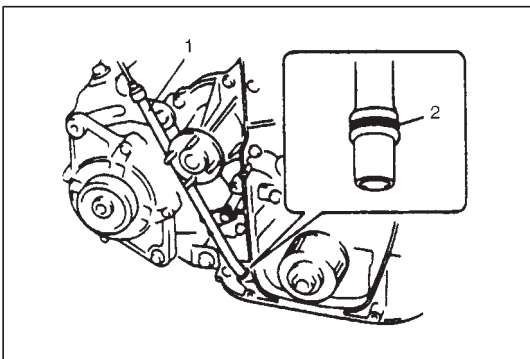

- 6) With engine oil applied to O-ring (2), install oil level gauge guide (1).
- 7) Install crankshaft pulley, water pump pulley, pump drive belt, cooling fan/clutch and fan shroud.

#### Tightening Torque

**Cooling fan/clutch nuts (G16 engine):**

**11 N·m (1.1 kg-m, 8.0 lb-ft)**

**Crankshaft pulley No.2 bolts (G16 engine):**

**16 N·m (1.6 kg-m, 11.5 lb-ft)**

- 8) Adjust cooling fan belt tension as previously outlined.
- 9) Connect negative cable (-) at battery.
- 10) Fill coolant.
- 11) After installation, check each part for leakage.

**For J20 engine**

- 1) Install new O-ring (1) to water pump (2).

**NOTE:**

**Do not forget to install dowel pins on water pump side before mounting water pump to engine block.**

- 2) Install water pump (1) by using new bolts (2) to cylinder block and tighten to specified torque.

**NOTE:**

**Use new bolts (total of 4) to install water pump to engine block. Failure to do so may result water leakage.**

**Tightening Torque**

**Water pump bolt (J20 engine) (a): 27 N·m (2.7 kg-m, 19.5 lb-ft)**

- 3) Install heater outlet pipe bolt (1).
- 4) Install generator belt. Refer to Section 6H.
- 5) Install radiator outlet hose to thermostat cap (2).
- 6) Fill coolant.
- 7) Connect negative cable at battery.

**For H25 engine**

- 1) Install new O-rings (3) to water pump (1).
- 2) Install water pump to cylinder block.

**Tightening Torque**

**Water pump bolt (H25 engine) (a): 27 N·m (2.7 kg-m, 19.5 lb-ft)**

- 3) Install timing chain cover. Refer to Section 6A2.
- 4) Install oil pan, front differential housing, P/S system, cooling system, intake manifold with throttle body and other parts.
- 5) Refill cooling system with coolant, front differential with gear oil, P/S system with specified fluid and engine with engine oil.
- 6) Check wheel alignment referring to Section 3A.
- 7) Verify that there is no fuel leakage, water leakage and oil leakage at each connection.
- 8) Connect negative (-) cable at battery.

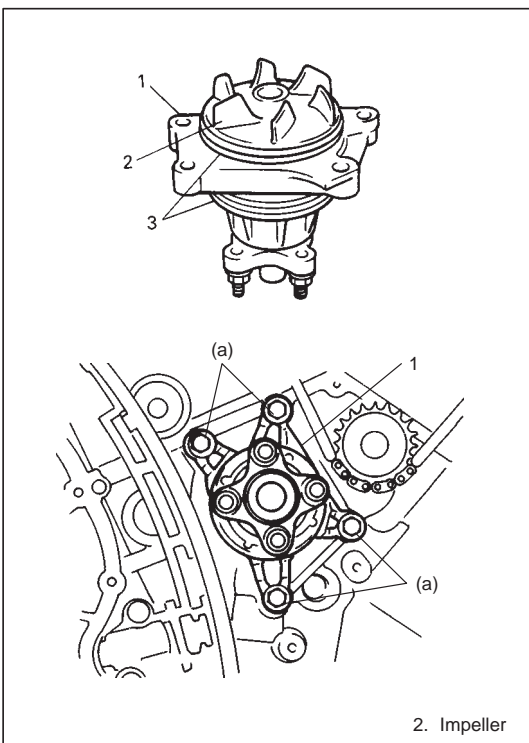
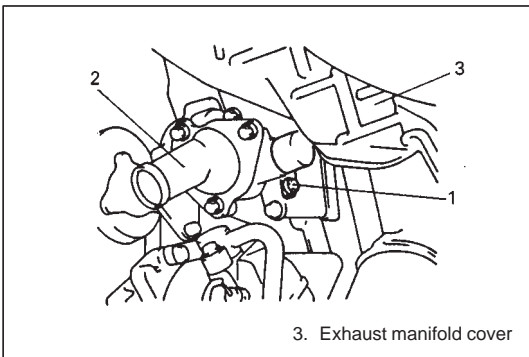
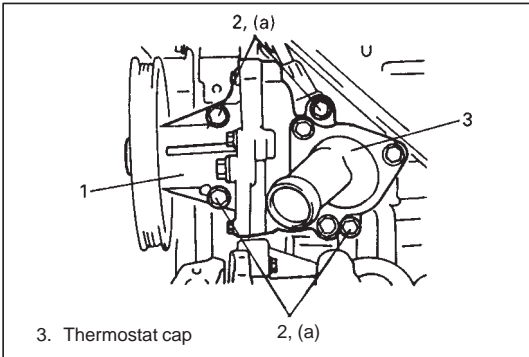
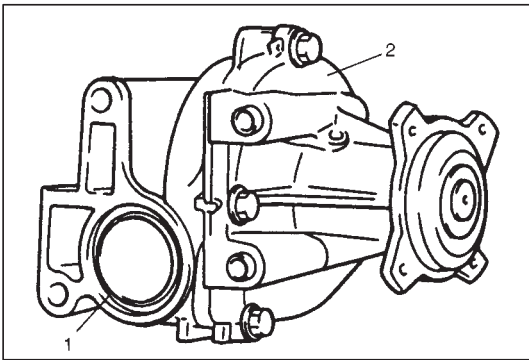

## ENGINE COOLANT TEMPERATURE (ECT) SENSOR

Refer to Section 6E1 (for G16 and J20 engine) or 6E2 (for H25 engine).

### REQUIRED SERVICE MATERIAL

MATERIAL	RECOMMENDED SUZUKI PRODUCT	USE
Ethylene glycol base coolant (Anti-freeze/Anti-corrosion coolant)	————	Additive to engine cooling system for improving cooling efficiency and for protection against rusting.
Sealant	SUZUKI BOND NO. 1215 (99000-31110)	Water outlet pipe bolt

### TIGHTENING TORQUE SPECIFICATION

Fastening parts	Tightening torque		
	N·m	kg-m	lb-ft
Cooling fan pulley adjusting and pivot bolts (J20 engine)	45	4.5	32.5
Cooling fan/clutch nuts (G16 engine)	11	1.1	8.0
Cooling fan/clutch nuts (H25 and J20 engines)	25	2.5	18.0
Water pump bolts (G16 engine)	12	1.2	8.5
Water pump bolts (J20 and H25 engines)	27	2.7	19.5
Crankshaft pulley No.2 bolts (G16 engine)	16	1.6	11.5

## SECTION 6C

# ENGINE FUEL

### CONTENTS

<p><b>GENERAL DESCRIPTION</b> ..... 6C-1</p> <p style="padding-left: 20px;">Fuel System ..... 6C-1</p> <p><b>DIAGNOSIS</b></p> <p style="padding-left: 20px;">Diagnosis Table ..... Refer to SECTION 6</p> <p><b>ON-VEHICLE SERVICE</b> ..... 6C-2</p> <p style="padding-left: 20px;">Precautions ..... Refer to SECTION 0A and 6</p> <p style="padding-left: 20px;">Fuel Pump ..... 6C-3</p>	<p style="padding-left: 20px;">Fuel Filter ..... 6C-3</p> <p style="padding-left: 20px;">Fuel Lines ..... 6C-4</p> <p style="padding-left: 20px;">Fuel Filler Cap ..... 6C-5</p> <p style="padding-left: 20px;">Fuel Tank ..... 6C-5</p> <p><b>TIGHTENING TORQUE SPECIFICATION</b> ..... 6C-8</p>
---	---

## GENERAL DESCRIPTION

### FUEL SYSTEM

The main components of the fuel system are fuel tank, fuel pump, fuel filter and fuel level gauge and it includes three lines, fuel feed line, fuel return line and fuel vapor line.

For the details of fuel flow and fuel vapor flow, refer to SECTION 6E1 or 6E2.

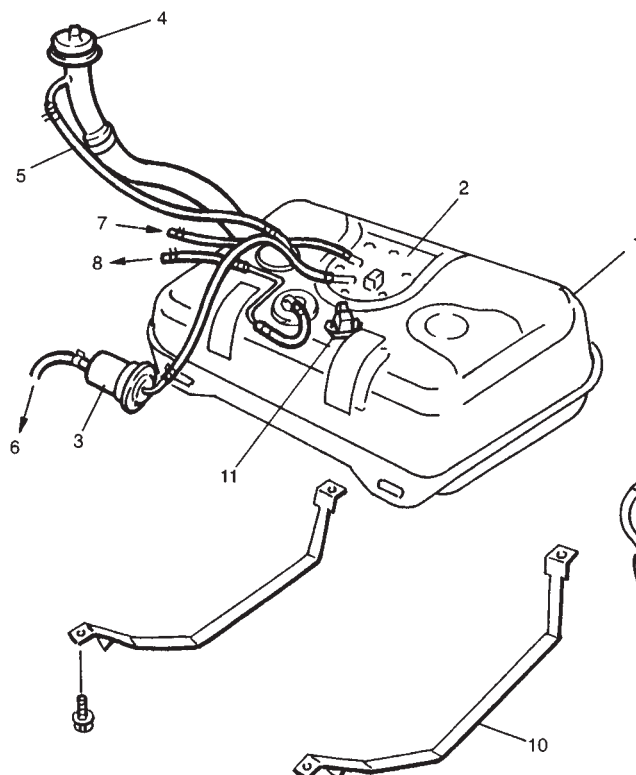

1. Fuel tank
2. Fuel pump (with fuel level gauge)
3. Fuel filter
4. Fuel filler cap
5. Breather hose
6. Fuel feed line (to delivery pipe)
7. Fuel return line (from delivery pipe)
8. Fuel vapor line (to EVAP canister)
9. Fuel tank protector
10. Belt
11. Fuel tank pressure sensor

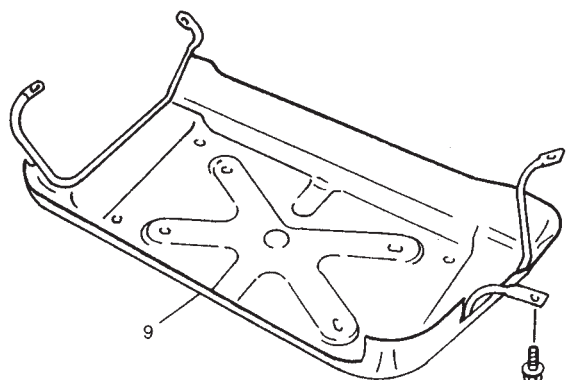

## DIAGNOSIS

### DIAGNOSIS TABLE

Refer to ENGINE DIAGNOSIS in SECTION 6.

## ON-VEHICLE SERVICE

### PRECAUTIONS

#### WARNING:

Before attempting service of any type on fuel system, following cautions should be always observed.

- Disconnect negative cable at battery.
- **DO NOT** smoke, and place "NO SMOKING" signs near work area.
- Be sure to have CO<sub>2</sub> fire extinguisher handy.
- Be sure to perform work in a well-ventilated area and away from any open flames (such as gas hot heater).
- Wear safety glasses.
- To release fuel vapor pressure in fuel tank, remove fuel filler cap from fuel filler neck and then reinstall it.
- As fuel feed line is still under high fuel pressure even after engine was stopped, loosening or disconnecting fuel feed line directly may cause dangerous spout of fuel to occur where loosened or disconnected. Before loosening or disconnecting fuel feed line, make sure to release fuel pressure according to procedure described in SECTION 6 or SECTION 6-1.
- A small amount of fuel may be released after the fuel line is disconnected.  
In order to reduce the chance of personal injury, cover the fitting to be disconnected with a shop cloth. Put that cloth in an approved container when disconnection is completed.
- Note that fuel hose connection varies with each type of pipe. Be sure to connect and clamp each hose correctly referring to the following.
- When performing any work that requires to lift up vehicle, check fuel hose clamp for rust.
- For other information, refer to "PRECAUTIONS" in SECTION 0A and SECTION 6 or SECTION 6-1 of this manual.

With short pipe, fit hose as far as it reaches pipe joint as shown.

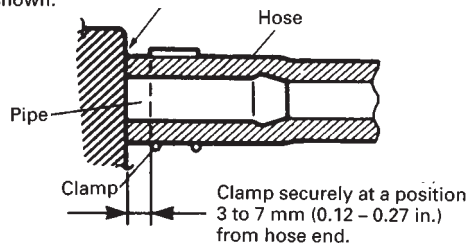

With following type pipe, fit hose as far as its peripheral projection as shown.

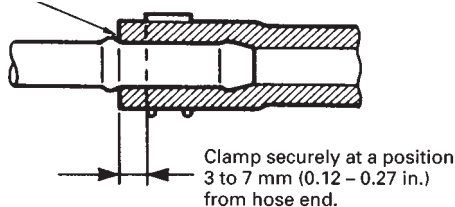

With bent pipe, fit hose as far its bent part as shown or till pipe is about 20 to 30 mm (0.79 - 1.18 in.) into the hose.

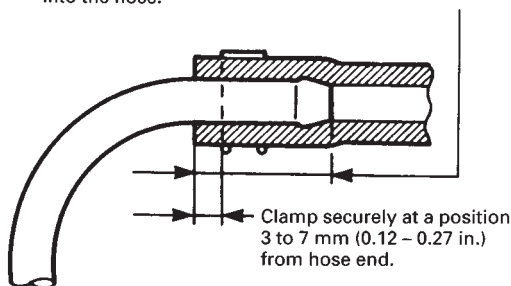

With straight pipe, fit hose till pipe is about 20 to 30 mm (0.79 - 1.18 in.) in the hose.

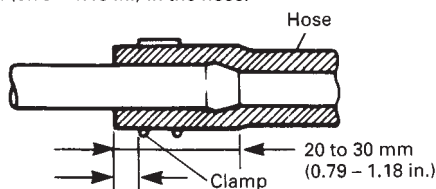

Clamp securely at a position 3 to 7 mm (0.12 - 0.27 in.) from hose end.

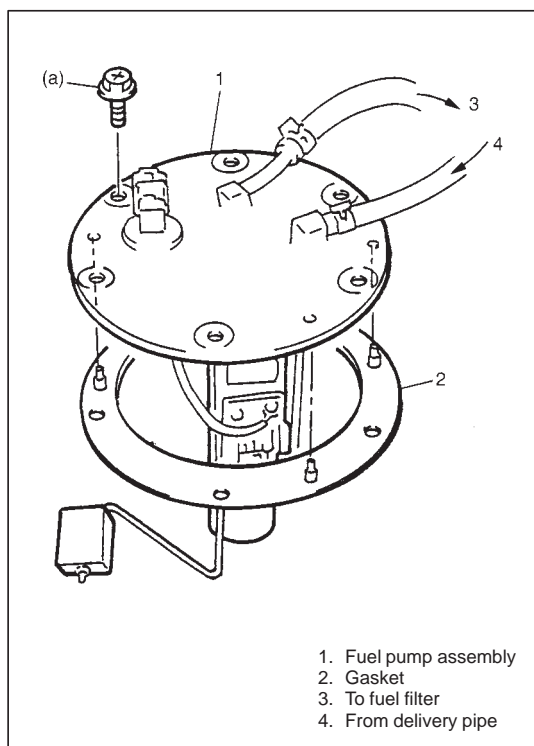

## FUEL PUMP

### REMOVAL

- 1) Remove fuel tank. Refer to "FUEL TANK" in this section.
- 2) Remove fuel pump assembly from fuel tank.

### INSPECTION

Check fuel pump filter for evidence of dirt and contamination. If present, clean and check for presence of dirt in fuel tank.

### INSTALLATION

Reverse removal procedure for installation noting the followings.

- Use new gasket.
- Tighten fuel pump bolts to specified torque.

#### Tightening Torque

Fuel pump bolt (a): 5.0 N·m (0.5 kg·m, 3.5 lb·ft)

## FUEL FILTER

### REMOVAL

- 1) Relieve fuel pressure in fuel feed line referring to SECTION 6 or SECTION 6-1.

#### CAUTION:

This work must not be done when engine is hot. If done so, it may cause adverse effect to catalyst.

- 2) Disconnect negative (-) cable at battery.
- 3) Hoist vehicle.
- 4) Disconnect inlet and outlet hoses (2), (3) from fuel filter (1).

#### WARNING:

A small amount of fuel may be released after fuel line is disconnected. In order to reduce the chance of personal injury, cover the fitting to be disconnected with a shop cloth. Be sure to put that cloth in an approved container when disconnection is completed.

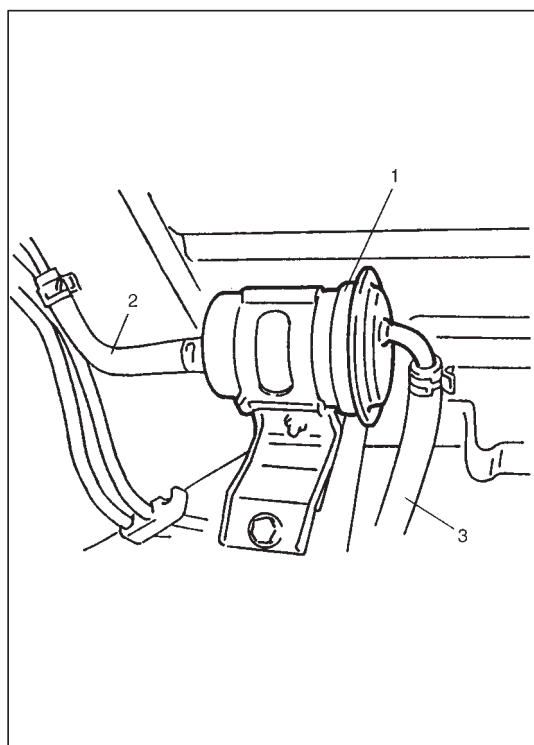

- 5) Remove fuel filter (1) from chassis frame.

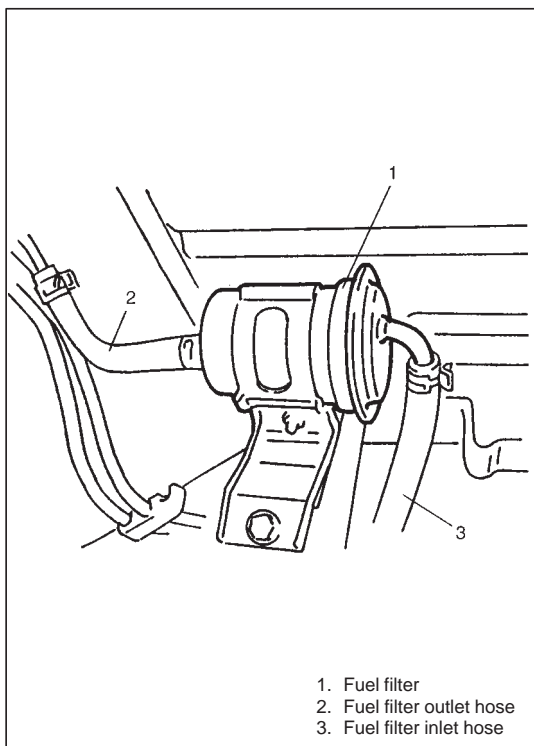

## INSTALLATION

Reverse removal procedure noting the following.

- Upon completion of installation, verify that there is no fuel leakage at each connection referring to SECTION 6 or SECTION 6-1.

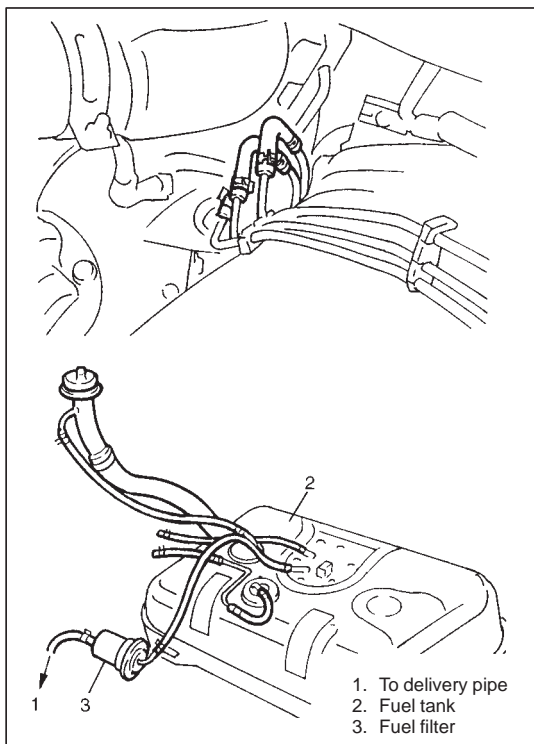

## FUEL LINES

### NOTE:

Due to the fact that fuel feed line is under high pressure, this system requires special consideration for service.

The feed pipe uses screw couplings and hose clamps.

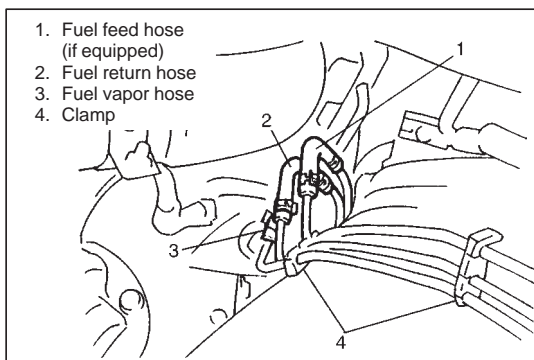

## INSPECTION

Visually inspect fuel lines for evidence of fuel leakage, hose cracking and deterioration, or damage. Make sure all clamps are secure. Replace parts as needed.

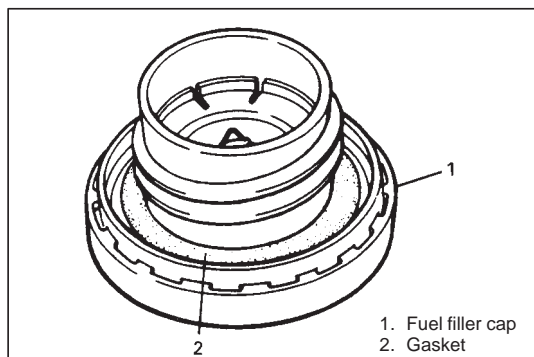

## FUEL FILLER CAP INSPECTION

Remove cap, and check gasket for even filler neck imprint, and deterioration or any damage.

If gasket is in malcondition, replace cap.

### CAUTION:

**If cap requires replacement, only a cap with the same features should be used. Failure to use correct cap can result in serious malfunction of the system.**

## FUEL TANK

### REMOVAL

- 1) Relieve fuel pressure in fuel feed line referring to SECTION 6 or SECTION 6-1.

### CAUTION:

**This work must not be done when engine is hot. If done so, it may cause adverse effect to catalyst.**

- 2) Disconnect negative (–) cable at battery.

- 3) Insert hose of a hand operated pump into fuel filler hose and drain fuel in space "A" in the figure (drain fuel through it till fuel stops).

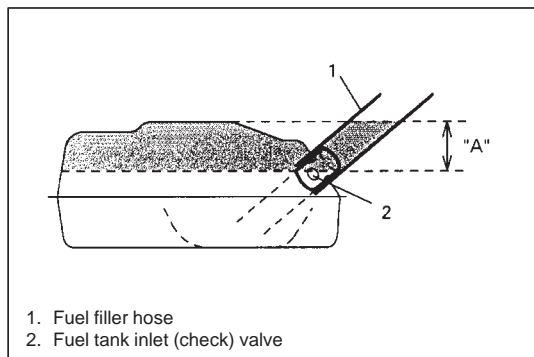

### CAUTION:

**Do not force hose of a hand operated pump into fuel tank. Doing so can damage inlet valve.**

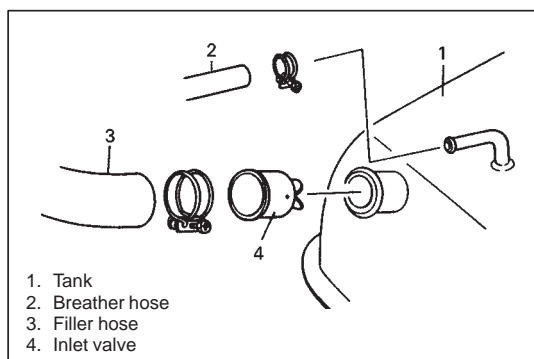

- 4) Remove fuel tank filler hose protector.
- 5) Disconnect filler hose from fuel tank and breather hose from fuel filler neck.
- 6) Remove fuel tank inlet valve. Use care not to damage inlet valve when removing.

- 7) Drain fuel tank by pumping fuel out through fuel tank filler. Use hand operated pump device to drain fuel tank.

### CAUTION:

**Never drain or store fuel in an open container due to possibility of fire or explosion.**

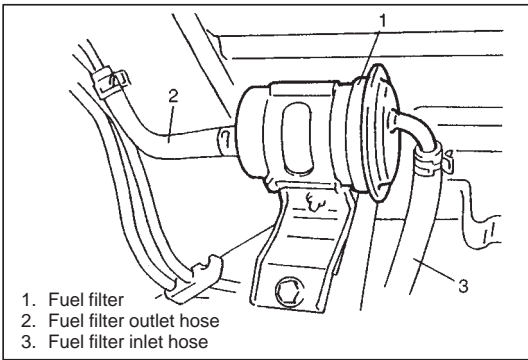

8) Disconnect fuel filter inlet hose from filter.

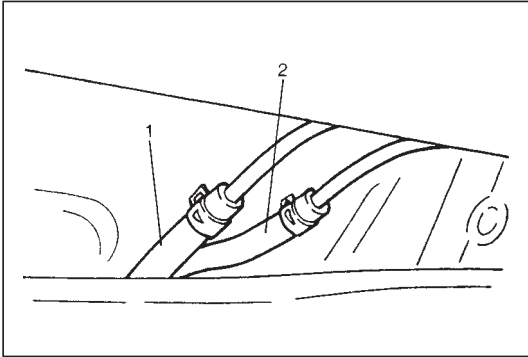

9) Disconnect fuel vapor hose (1) and return hose (2) from pipes.  
10) Remove fuel tank protector from vehicle.

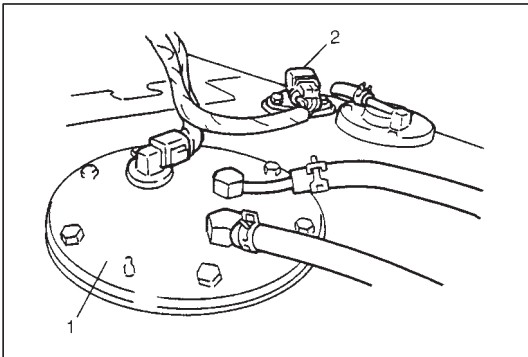

11) Lower fuel tank gradually while holding it horizontally and pull out each coupler from fuel pump (1) and fuel tank pressure sensor (2).

### INSPECTION

After removing fuel tank, check hoses and pipes connected to fuel tank for leaks, loose connections, deterioration or damage. Also check fuel pump and level gauge gaskets for leaks, visually inspect fuel tank for leaks and damage.

Replace any damaged or malconditioned parts.

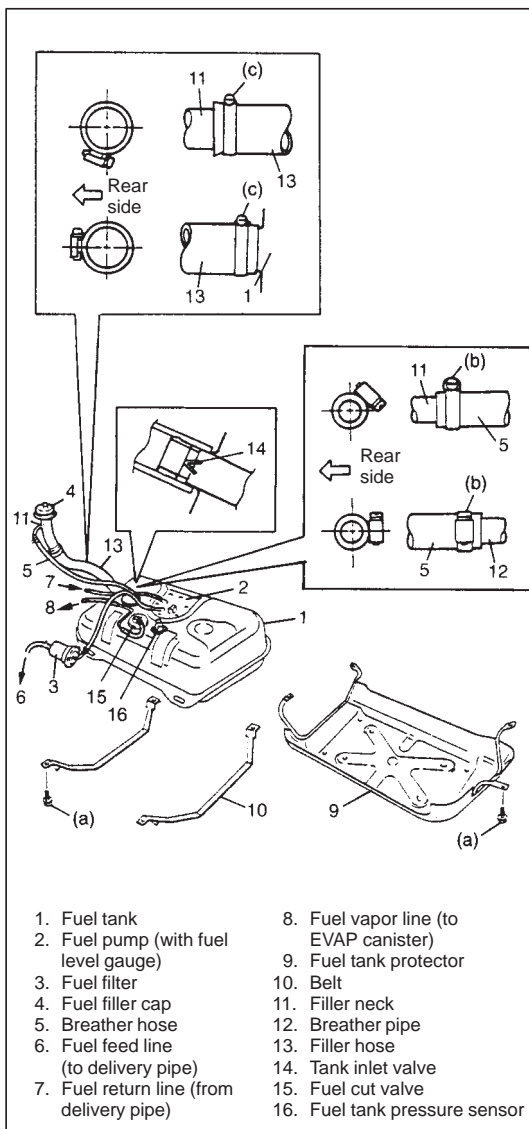

## INSTALLATION

- 1) Install fuel pump assembly and fuel cut valve to fuel tank. Refer to "FUEL PUMP" in this section.
- 2) Connect fuel hoses to fuel tank, fuel cut valve and fuel pump assembly.  
After connecting, clamp hoses securely.
- 3) Install inlet valve to fuel tank.  
If deformed or damaged in any other way, replace with a new one.
- 4) Install fuel tank by using fuel tank belts and then install protector to vehicle.

### Tightening Torque

**Fuel tank bolt (a): 50 N·m (5.0 kg-m, 36.5 lb-ft)**

**Fuel tank protector bolt (a): (50 N·m (5.0 kg-m, 36.5 lb-ft)**

- 5) Connect fuel filler hose to fuel tank and breather hose to fuel filler neck. Clamp them securely.

### Tightening Torque

**Breather hose clamp (b): 2.0 N·m (0.2 kg-m, 2.0 lb-ft)**

**Fuel filler hose clamp (c): 4.0 N·m (0.4 kg-m, 3.0 lb-ft)**

- 6) Install fuel filler hose protector.

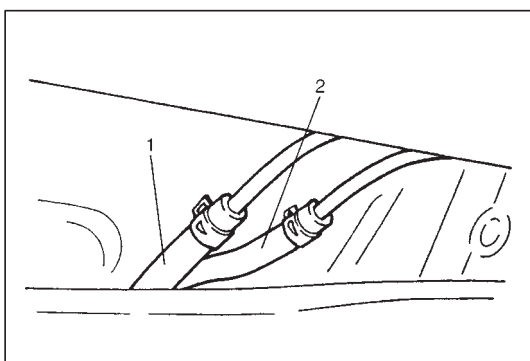

- 7) Connect fuel vapor hose (1) and return hose (2) to fuel pipe and clamp them securely.

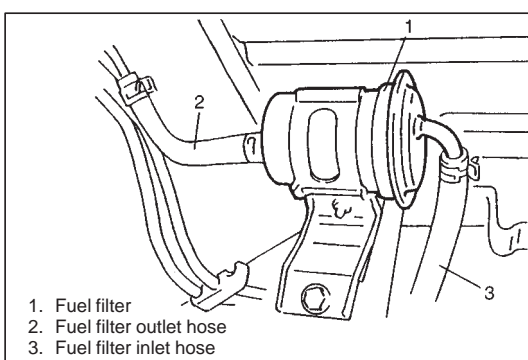

- 8) Connect fuel filter inlet hose to fuel filter.

- 9) Connect coupler to fuel pump assembly and tank pressure sensor respectively.
- 10) Connect negative (-) cable to battery.
- 11) Upon completion of installation, check fuel system for leakage.

### FUEL TANK PURGING PROCEDURE

**CAUTION:**

**This purging procedure will NOT remove all fuel vapor. Do not attempt any repair on tank where heat or flame is required, as an explosion resulting in personal injury could occur.**

The following procedure is used for purging the fuel tank.

- 1) After removing fuel tank, remove all hoses and fuel pump assembly from fuel tank.
- 2) Drain all remaining fuel from tank.
- 3) Move tank to flushing area.
- 4) Fill tank with warm water or tap water, and agitate vigorously and drain. Repeat this washing until inside of tank is clean.  
Replace tank if its inside is rusty.
- 5) Completely flush out remaining water after washing.

### TIGHTENING TORQUE SPECIFICATION

Fastening portion	Tightening torque		
	N·m	kg-m	lb-ft
Fuel pump assembly bolt	5.0	0.5	3.5
Fuel tank bolt	50	5.0	36.5
Fuel tank protector bolt			
Breather hose clamp	2.0	0.2	2.0
Fuel filler hose clamp	4.0	0.4	3.0

## SECTION 6E2

# ENGINE AND EMISSION CONTROL SYSTEM (SEQUENTIAL MULTIPOINT FUEL INJECTION FOR H25 ENGINE)

**WARNING:**

For vehicles equipped with Supplemental Restraint (Air Bag) System

- Service on and around the air bag system components or wiring must be performed only by an authorized SUZUKI dealer. Refer to “Air Bag System Components and Wiring Location View” under “General Description” in air bag system section in order to confirm whether you are performing service on or near the air bag system components or wiring. Please observe all WARNINGS and “Service Precautions” under “On-Vehicle Service” in air bag system section before performing service on or around the air bag system components or wiring. Failure to follow WARNINGS could result in unintentional activation of the system or could render the system inoperative. Either of these two conditions may result in severe injury.
- Technical service work must be started at least 90 seconds after the ignition switch is turned to the “LOCK” position and the negative cable is disconnected from the battery. Otherwise, the system may be activated by reserve energy in the Sensing and Diagnostic Module (SDM).

**NOTE:**

Whether following systems (parts) are used in the particular vehicle or not depends on specifications. Be sure to bear this in mind when performing service work.

- EGR valve
- Heated oxygen sensor(s) or CO adjusting resistor
- Three way catalytic converter(s)
- CKP sensor
- MAP sensor
- Monitor connector

## CONTENTS

<b>GENERAL DESCRIPTION</b> .....	6E2- 3	Idle Air Control Valve .....	6E2-21
AIR INTAKE SYSTEM .....	6E2- 6	<b>FUEL DELIVERY SYSTEM</b> .....	6E2-23
FUEL DELIVERY SYSTEM .....	6E2- 7	Fuel Pressure Inspection .....	6E2-23
ELECTRONIC CONTROL SYSTEM .....	6E2- 8	Fuel Pump .....	6E2-24
ENGINE & EMISSION CONTROL		Fuel Pressure Regulator .....	6E2-25
INPUT/OUTPUT TABLE .....	6E2-12	Fuel Injector .....	6E2-26
<b>ON-VEHICLE SERVICE</b> .....	6E2-13	<b>ELECTRONIC CONTROL SYSTEM</b> ....	6E2-31
General .....	6E2-14	ECM (PCM) .....	6E2-31
Accelerator Cable Adjustment .....	6E2-14	MAF Sensor .....	6E2-32
A/T Throttle Cable Adjustment .....	6E2-14	IAT Sensor .....	6E2-34
Idle Speed/Idle Air Control Duty		TP Sensor .....	6E2-35
Inspection .....	6E2-15	ECT Sensor .....	6E2-37
AIR INTAKE SYSTEM .....	6E2-18	HO2S Sensor 1 .....	6E2-38
Throttle Body .....	6E2-18	HO2S Sensor 2 .....	6E2-39

VSS .....	6E2-40	EGR System (if equipped) .....	6E2-44
MAP Sensor .....	6E2-41	Evaporative Emission Control System .....	6E2-46
CKP Sensor .....	6E2-41	PCV System .....	6E2-46
Main Relay .....	6E2-42	<b>TIGHTENING TORQUE</b>	
Fuel Pump Relay .....	6E2-43	<b>SPECIFICATIONS</b> .....	6E2-48
Fuel Cut Operation .....	6E2-43	<b>SPECIAL TOOLS</b> .....	6E2-48
EMISSION CONTROL SYSTEM .....	6E2-44		

## GENERAL DESCRIPTION

The engine and emission control system has 4 major sub-systems: air intake system, fuel delivery system, electronic control system and emission control system.

Air intake system includes air cleaner, mass air flow sensor, throttle body, idle air control valve and intake manifold.

Fuel delivery system includes fuel pump, delivery pipe, fuel pressure regulator, fuel injectors, etc.

Electronic control system includes ECM (PCM), various sensors and controlled devices.

Emission control system includes EGR, EVAP and PCV systems.

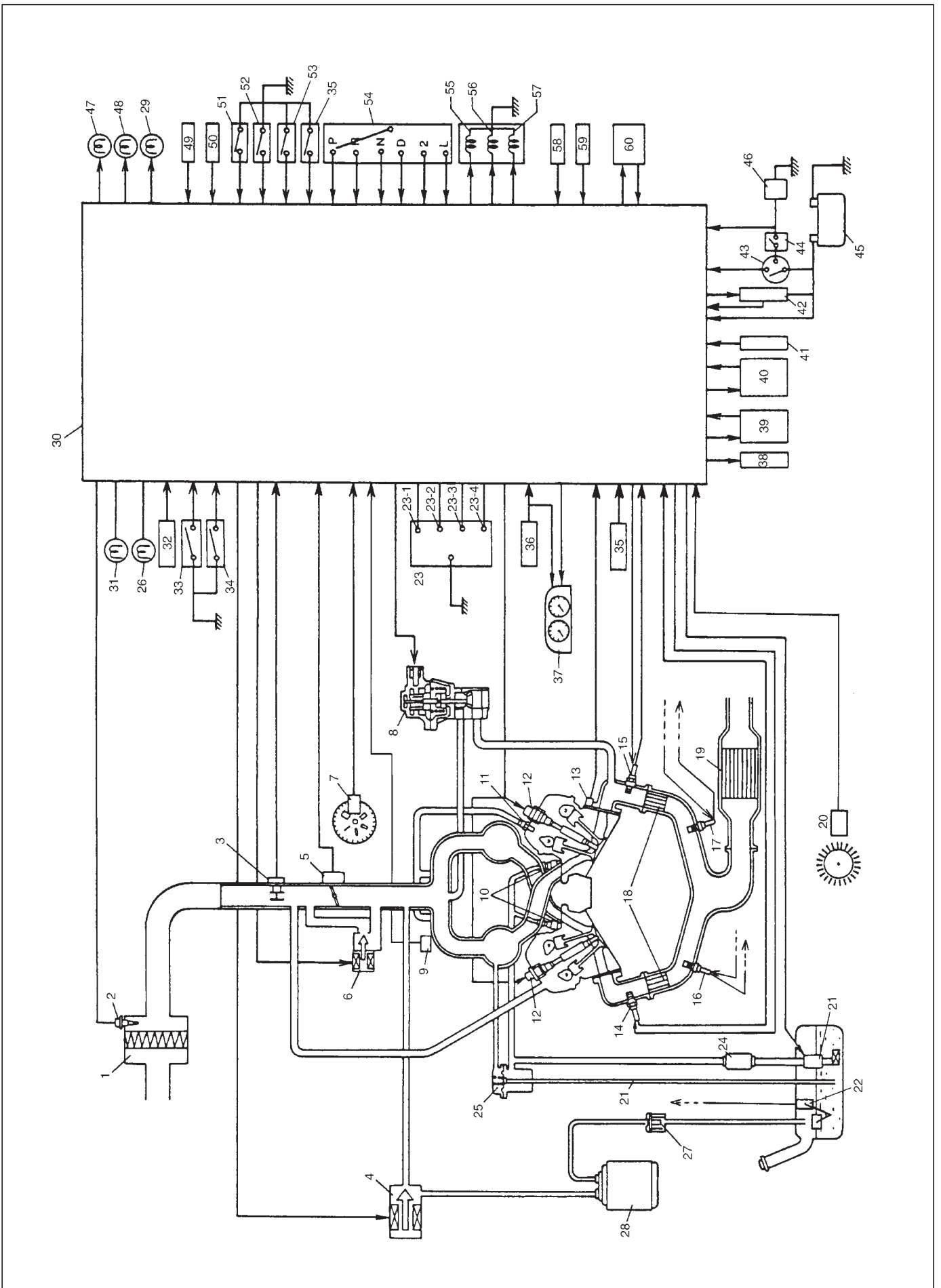

- |   |   |  |
|---|---|--|
| 1. Air cleaner                                  | 21. Fuel pump   | 40. Data link connector/Immobilizer control module (if equipped) |
| 2. Intake air temp. sensor                      | 22. Fuel level sensor   | 41. ABS control module (if equipped)                             |
| 3. Mass air flow sensor                         | 23. Monitor connector (if equipped)                           | 42. Main relay   |
| 4. EVAP canister purge valve                    | 23-1. Diag. switch terminal                                   | 43. Ignition switch  |
| 5. Throttle position sensor                     | 23-2. Test switch terminal                                    | 44. Park/Neutral position switch                                 |
| 6. Idle air control valve                       | 23-3. Output duty select switch terminal                      | 45. Battery  |
| 7. Camshaft position sensor                     | 23-4. Duty output terminal                                    | 46. Starter magnetic switch                                      |
| 8. EGR valve (if equipped)                      | 24. Fuel filter   | 47. "O/D OFF" lamp   |
| 9. Manifold absolute pressure sensor            | 25. Fuel pressure regulator                                   | 48. "POWER" lamp   |
| 10. Fuel injector                               | 26. Immobilizer indicator lamp                                | 49. Lighting switch  |
| 11. PCV valve                                   | (if equipped)   | 50. Stop lamp switch   |
| 12. Ignition coil assembly                      | 27. Tank pressure control valve                               | 51. O/D cut switch   |
| 13. Engine coolant temp. sensor                 | 28. EVAP canister   | 52. POWER/NORMAL change switch                                   |
| 14. Heated oxygen sensor (bank 1 sensor 1)      | 29. 4WD lamp  | 53. 4WD low switch   |
| 15. Heated oxygen sensor (bank 2 sensor 1)      | 30. ECM/PCM (Engine control module/Powertrain control module) | 54. Transmission range switch                                    |
| 16. Heated oxygen sensor (bank 1 sensor 2)      | 31. Malfunction indicator lamp                                | 55. Solenoid valve A   |
| 17. Heated oxygen sensor (bank 2 sensor 2)      | 32. Electric load   | 56. Solenoid valve B   |
| 18. Warm-up three way catalytic converter       | – Rear defogger (if equipped)                                 | 57. TCC solenoid valve   |
| 19. Three way catalytic converter (if equipped) | 33. Power steering pressure switch                            | 58. A/T input speed sensor                                       |
| 20. Crank shaft position sensor (if equipped)   | (if equipped)   | 59. A/T vehicle (output) speed sensor                            |
|   | 34. Heater blower fan switch                                  | 60. 4WD actuator   |
|   | 35. 4WD switch  |  |
|   | 36. Vehicle speed sensor                                      |  |
|   | 37. Combination meter   |  |
|   | 38. A/C condenser fan relay (if equipped)                     |  |
|   | 39. A/C controller (if equipped)                              |  |

## AIR INTAKE SYSTEM

The main components of the air intake system are air cleaner, mass air flow sensor, air cleaner intake air pipe, throttle body, intake collector, idle air control valve and intake manifold.

The air (by the amount corresponding to the throttle valve opening and engine speed) is filtered by the air cleaner, passes through the throttle body, is distributed by the intake manifold and finally drawn into each combustion chamber.

When the idle air control valve is opened according to the signal from ECM (PCM), the air bypasses the throttle valve through bypass passage and is finally drawn into the intake manifold.

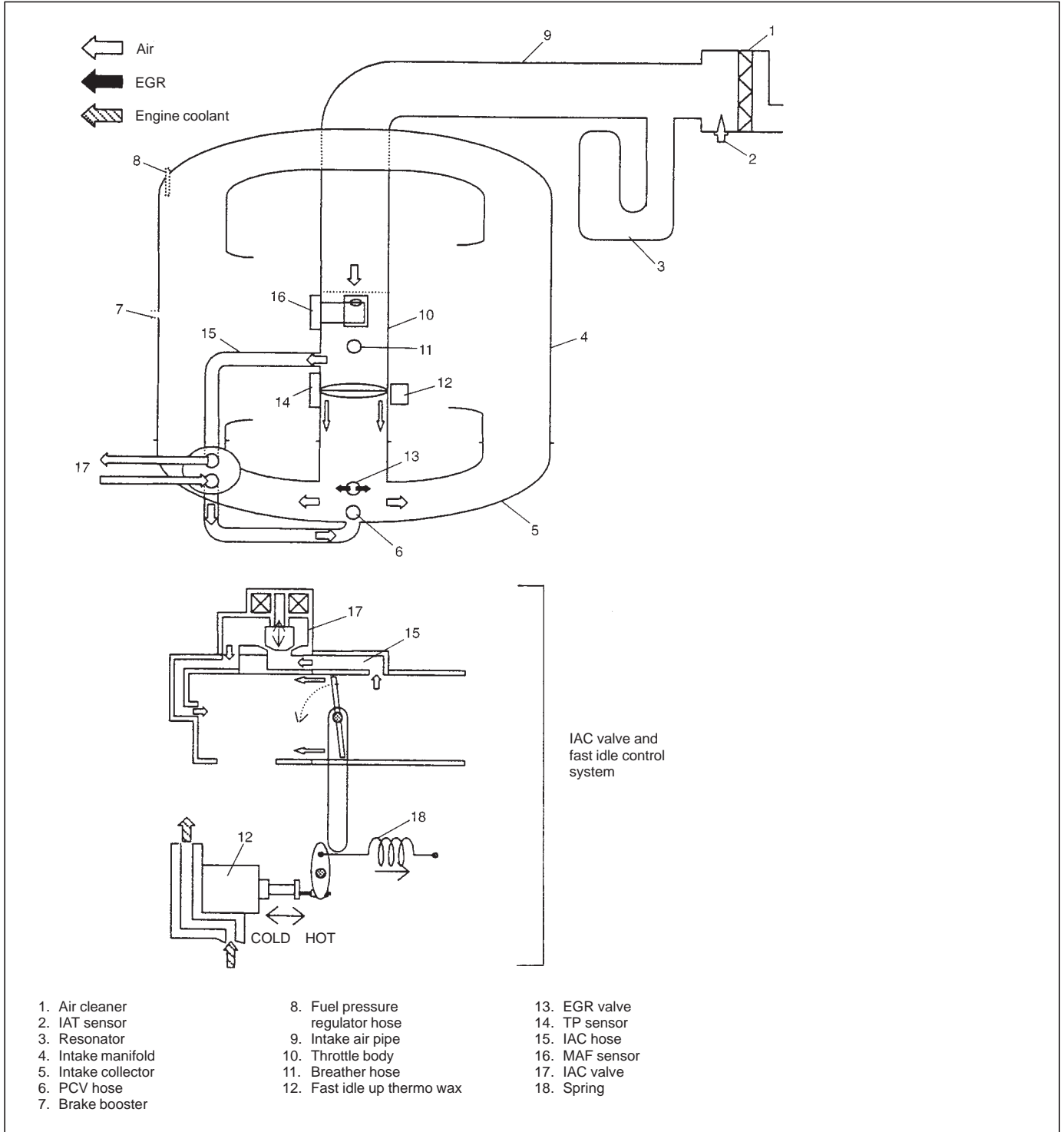

## FUEL DELIVERY SYSTEM

The fuel delivery system consists of the fuel tank, fuel pump, fuel filter, fuel pressure regulator, delivery pipe and fuel injectors.

The fuel in the fuel tank is pumped up by the fuel pump, filtered by the fuel filter and fed under pressure to each injector through the delivery pipe.

As the fuel pressure applied to the injector (the fuel pressure in the fuel feed line) is always kept a certain

amount higher than the pressure in the intake manifold by the fuel pressure regulator, the fuel is injected into the intake port of the cylinder head when the injector opens according to the injection signal from ECM (PCM).

The fuel relieved by the fuel pressure regulator returns through the fuel return line to the fuel tank.

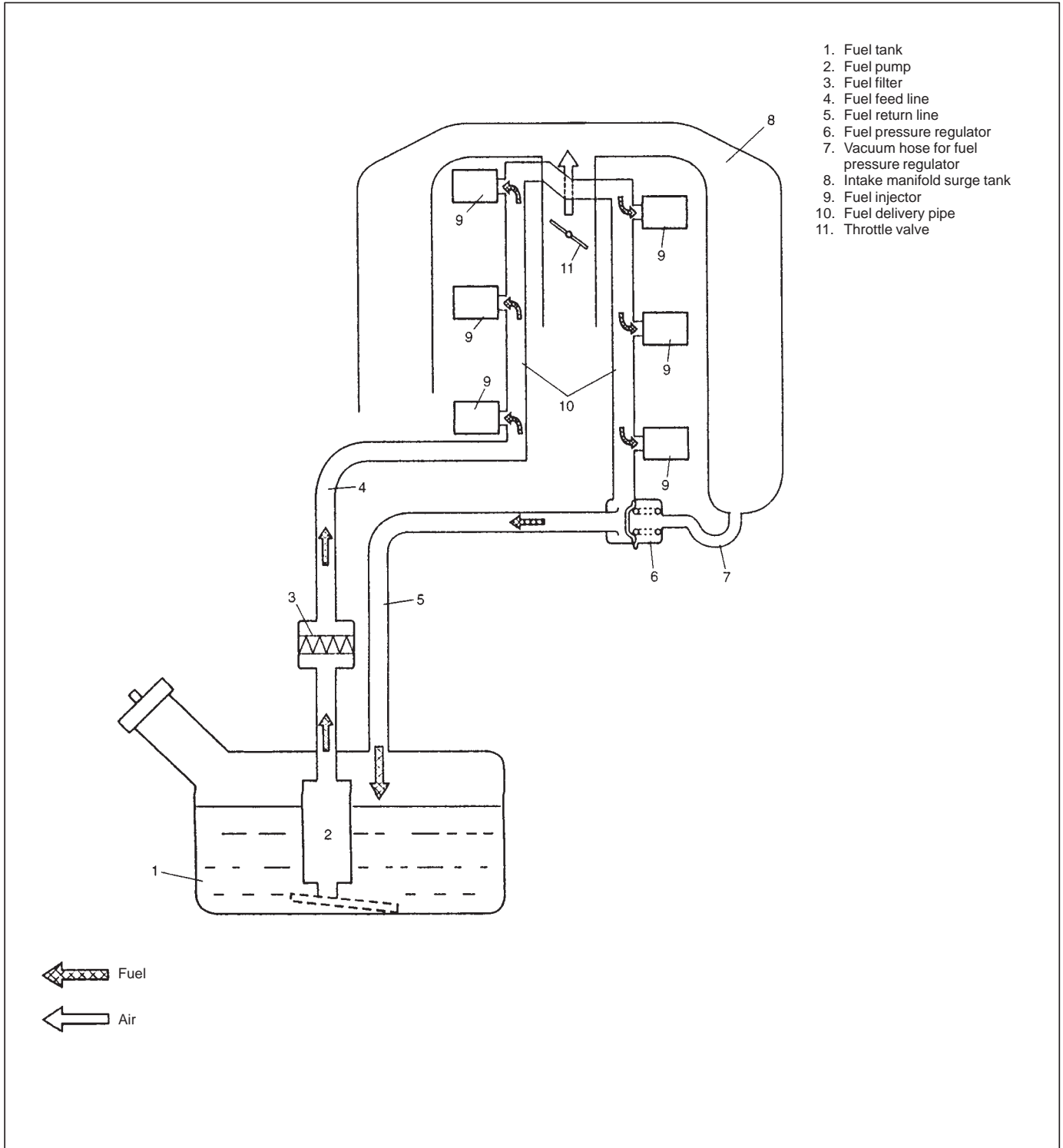

## ELECTRONIC CONTROL SYSTEM

The electronic control system consists of 1) various sensors which detect the state of engine and driving conditions, 2) ECM (PCM) which controls various devices according to the signals from the sensors and 3) various controlled devices.

Functionally, it is divided into the following sub systems:

- Fuel injection control system
- Heated oxygen sensor heater control system (if equipped)

- Idle air control system
- Fuel pump control system
- Evaporative emission control system
- Ignition control system
- EGR system

Also, with A/T model, PCM controls A/T.

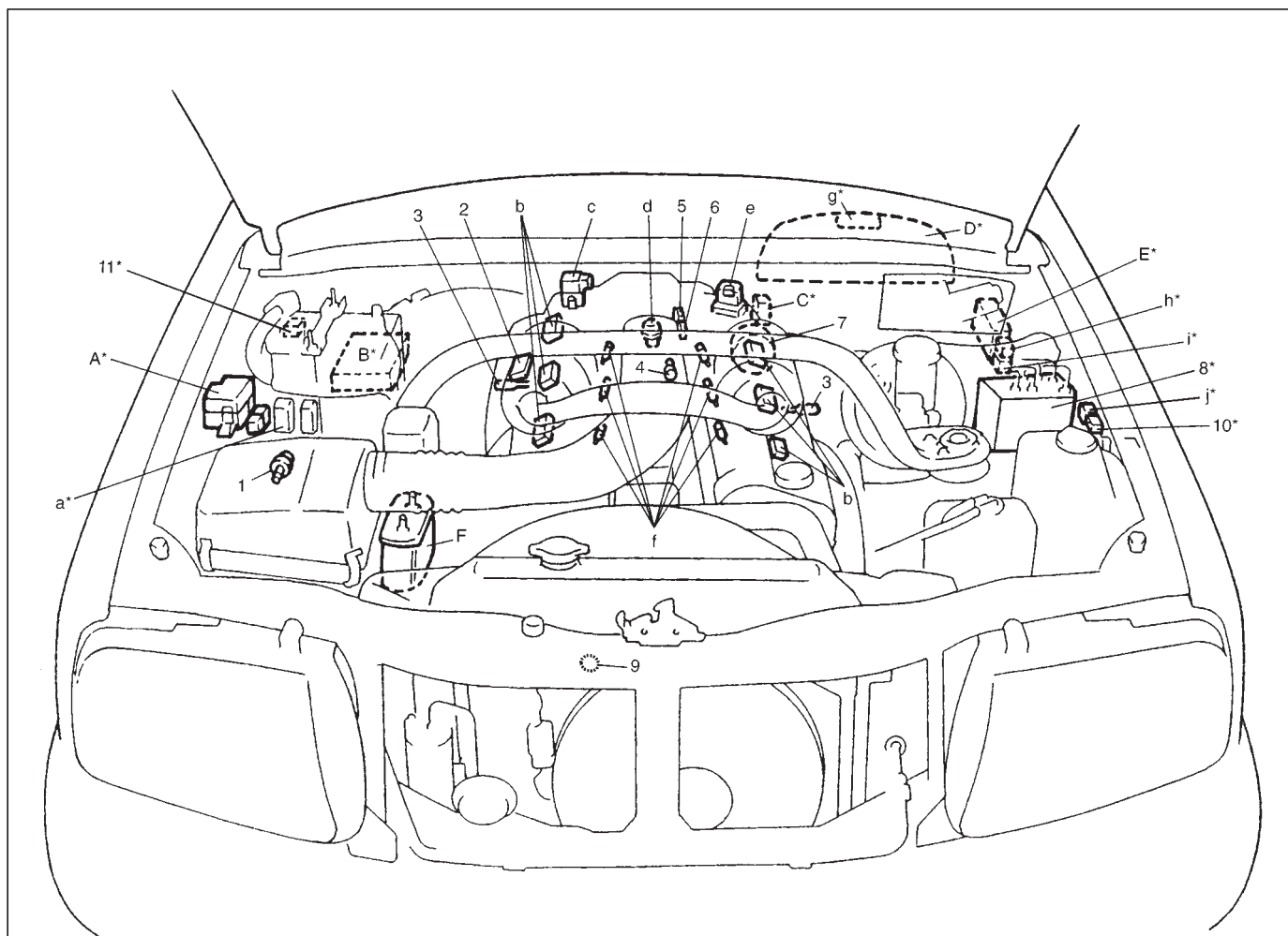

### INFORMATION SENSORS

1. IAT sensor
2. MAP sensor (if equipped)
3. Heated oxygen sensor (sensor 1) (if equipped)
4. ECT sensor
5. TP sensor
6. MAF sensor
7. Camshaft position sensor (CMP sensor)
8. ABS control module (if equipped)
9. Crank shaft position sensor (CKP sensor) (if equipped)
10. Monitor connector (if equipped)
11. CO adjusting resistor (if equipped)

### CONTROLLED DEVICES

- a : A/C condenser fan motor relay (if equipped)
- b : Ignition coil assemblies
- c : EVAP canister purge valve
- d : EGR valve (if equipped)
- e : Idle air control valve
- f : Injectors
- g : Malfunction indicator lamp
- h : Fuel pump relay
- i : Main relay
- j : Oxygen sensor heater relay (if equipped)

### OTHERS

- A : Main fuse box
- B : ECM (PCM)
- C : Data link connector
- D : Combination meter
- E : Fuse box
- F : EVAP canister

### NOTE:

Above figure shows left-hand steering vehicle. For right-hand steering vehicle, parts with (\*) are installed at the other side.

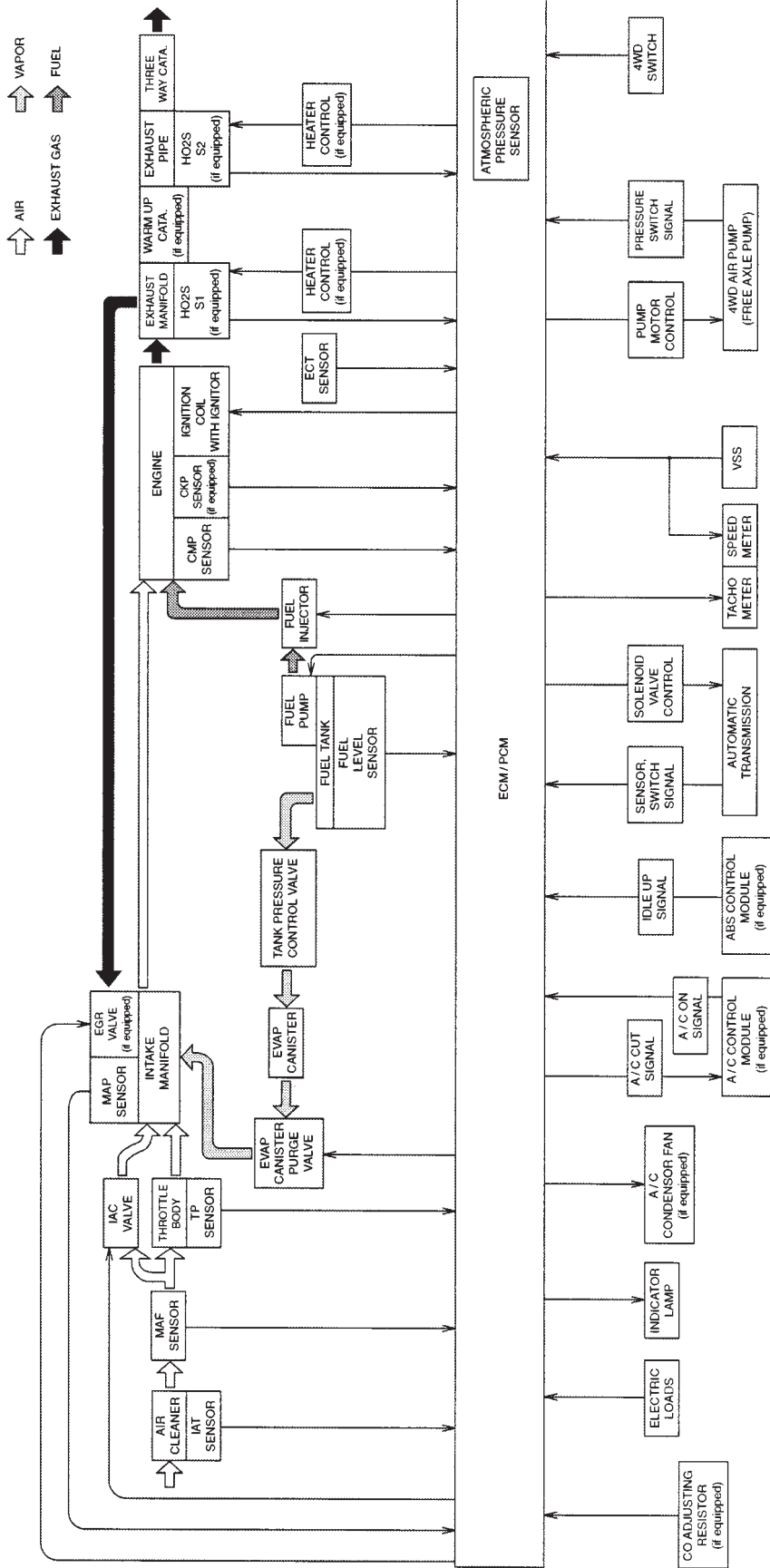

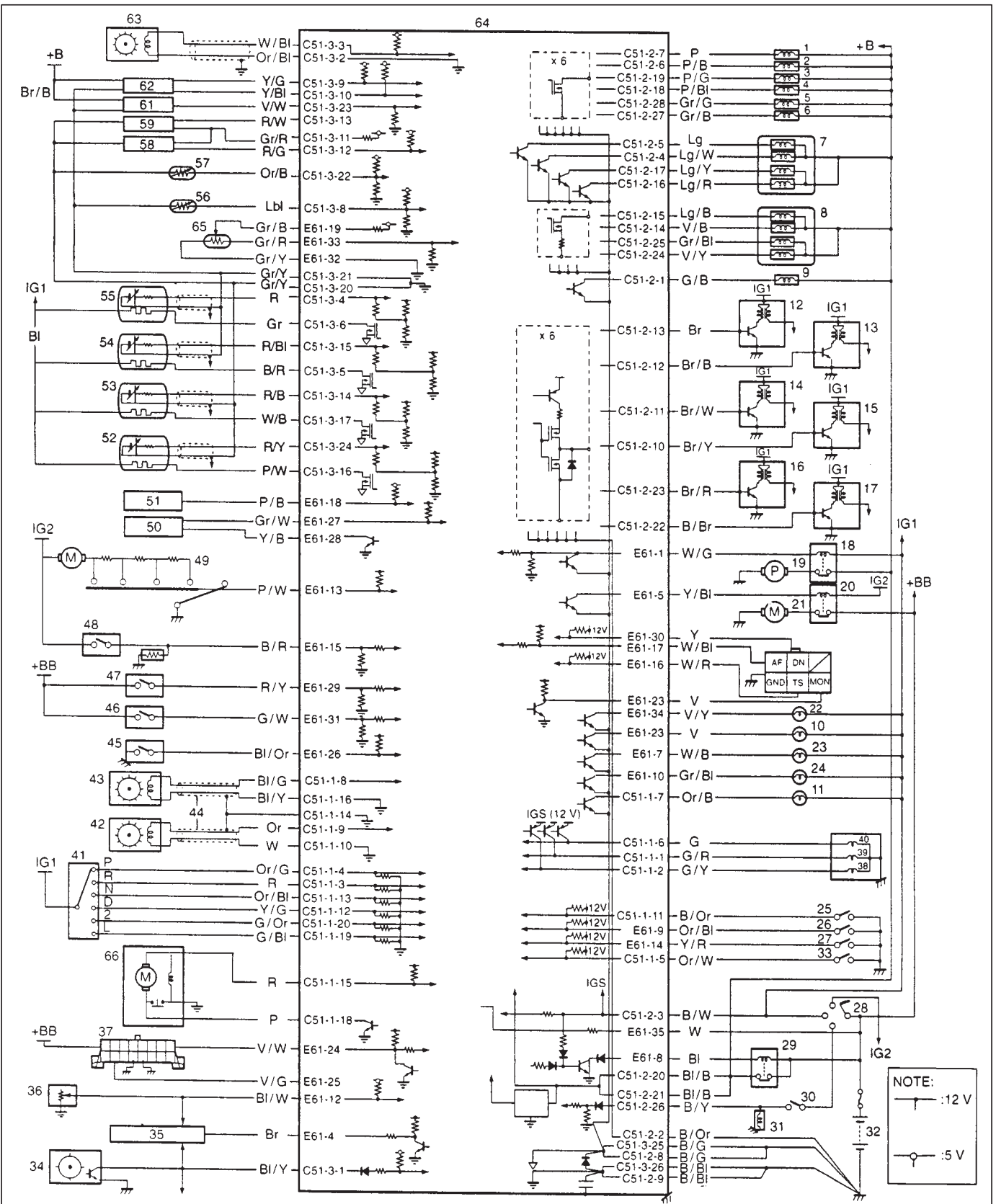

TERMINAL ARRANGEMENT OF ECM (PCM) CONNECTOR (VIEWED FROM HARNESS SIDE)

E61

C51-3

C51-1

C51-2

8	7	6	5	4	3	2	1	6	5	4	3	2	1	4	3	2	1	7	6	5	4	3	2	1										
23	22	21	20	19	18	17	16	15	14	13	12	11	10	9	8	7	6	5	4	3	2	1												
35	34	33	32	31	30	29	28	27	26	25	24	23	22	21	20	19	18	17	16	15	14	13	12	11	10	9	8	7	6	5	4	3	2	1

1. Fuel injector No.1
2. Fuel injector No.2
3. Fuel injector No.3
4. Fuel injector No.4
5. Fuel injector No.5
6. Fuel injector No.6
7. EGR valve (if equipped)
8. Idle air control (IAC) valve
9. EVAP canister purge valve
10. Immobilizer indicator lamp
11. 4WD lamp
12. Ignition coil assembly for No.1 spark plug
13. Ignition coil assembly for No.2 spark plug
14. Ignition coil assembly for No.3 spark plug
15. Ignition coil assembly for No.4 spark plug
16. Ignition coil assembly for No.5 spark plug
17. Ignition coil assembly for No.6 spark plug
18. Fuel pump relay
19. Fuel pump
20. A/C condenser fan relay (if equipped)
21. A/C condenser fan motor (if equipped)
22. Malfunction indicator lamp
23. "O/D OFF" lamp
24. "POWER" lamp
25. 4WD switch
26. Power/Normal change switch
27. O/D cut switch
28. Ignition switch
29. Main relay
30. Transmission range switch (Park/neutral position switch)
31. Starter magnetic switch
32. Battery
33. 4WD low switch
34. Vehicle speed sensor
35. Combination meter
36. Fuel level sensor
37. Data link connector
38. TCC solenoid valve
39. Solenoid valve No.1(-B)
40. Solenoid valve No.1(-A)
41. Transmission range switch (Sensor)
42. A/T vehicle (output) speed sensor
43. A/T input speed sensor
44. Shield wire
45. Power steering pressure switch
46. Stop lamp switch (Brake pedal switch)
47. Lighting switch
48. Rear defogger switch (if equipped)
49. Heater blower switch
50. A/C amplifier (if equipped)
51. ABS control module (if equipped)
52. HO2S Bank 2 Sensor 2 (if equipped)
53. HO2S Bank 1 Sensor 2 (if equipped)
54. HO2S Bank 2 Sensor 1 (if equipped)
55. HO2S Bank 1 Sensor 1 (if equipped)
56. Intake air temp. sensor
57. Engine coolant temp. sensor
58. Throttle position sensor
59. MAP sensor (if equipped)
60. Monitor connector (if equipped)
61. Mass air flow sensor
62. Camshaft position sensor
63. CKP sensor (if equipped)
64. ECM (PCM)
65. CO adjusting resistor (if equipped)
66. 4WD actuator

TERMINAL	CIRCUIT	TERMINAL	CIRCUIT
E61-1	Fuel pump relay	C51-3-18	—
E61-2	—	C51-3-19	—
E61-3	—	C51-3-20	Ground
E61-4	Tachometer	C51-3-21	Ground
E61-5	A/C condenser fan motor (if equipped)	C51-3-22	Engine coolant temp. sensor
		C51-3-23	Mass air flow sensor
E61-6	—	C51-3-24	Heated oxygen sensor (bank 2 sensor 2) (if equipped)
E61-7	"O/D OFF" lamp (A/T vehicle)		
E61-8	Main relay	C51-3-25	Ground
E61-9	Power/normal change switch (A/T vehicle)	C51-3-26	Ground
		C51-1-1	Shift solenoid No.1-B (A/T vehicle)
E61-10	"POWER" lamp (A/T vehicle)	C51-1-2	Shift solenoid No.2 (TCC) (A/T vehicle)
E61-11	—		
E61-12	Fuel level sensor	C51-1-3	Transmission range switch "R" (A/T vehicle)
E61-13	Heater blower fan switch		
E61-14	O/D OFF switch (A/T vehicle)	C51-1-4	Transmission range switch "P" (A/T vehicle)
E61-15	Rear defogger switch (if equipped)		
E61-16	Test switch terminal (Vehicle with monitor connector)	C51-1-5	4WD low switch (if equipped) (A/T vehicle)
		C51-1-6	Shift solenoid No.1-A (A/T vehicle)
E61-17	Output duty select switch terminal (Vehicle with monitor connector)	C51-1-7	4WD lamp
E61-18	ABS control module (if equipped)	C51-1-8	A/T input speed sensor (A/T vehicle)
E61-19	CO adjusting resistor (if equipped)	C51-1-9	A/T output speed sensor (A/T vehicle)
E61-20	—	C51-1-10	A/T output speed sensor (A/T vehicle)
E61-21	—		
E61-22	—	C51-1-11	4WD switch
E61-23	Immobilizer indicator lamp (Vehicle without monitor connector) Duty output terminal (Vehicle with monitor connector)	C51-1-12	Transmission range switch "D" (A/T vehicle)
		C51-1-13	Transmission range switch "N" (A/T vehicle)
E61-24	Data link connector 5 V (if equipped)	C51-1-14	Shield wire ground for A/T input speed sensor and A/T output speed sensor (A/T vehicle)
E61-25	Data link connector 12 V		
E61-26	Power steering pressure switch	C51-1-15	4WD actuator
E61-27	A/C cut switch (if equipped)	C51-1-16	A/T input speed sensor (A/T vehicle)
E61-28	A/C signal (if equipped)		
E61-29	Lighting switch	C51-1-17	—
E61-30	Diag. switch terminal (vehicle with monitor connector)	C51-1-18	4WD pressure switch
E61-31	Stop lamp switch (A/T vehicle)	C51-1-19	Transmission range switch "L" (A/T vehicle)
E61-32	CO adjusting resistor (if equipped)		
E61-33	Power source for CO adjusting resistor (if equipped)	C51-1-20	Transmission range switch "2" (A/T vehicle)
E61-34	Malfunction indicator lamp	C51-2-1	EVAP canister purge valve
E61-35	Power source for back up	C51-2-2	Ground
C51-3-1	Vehicle speed sensor	C51-2-3	Ignition switch
C51-3-2	Crankshaft position sensor (-) (if equipped)	C51-2-4	EGR valve (stepper motor coil 2)
		C51-2-5	EGR valve (stepper motor coil 1)
C51-3-3	Crankshaft position sensor (+) (if equipped)	C51-2-6	Fuel injector No.2
		C51-2-7	Fuel injector No.1
C51-3-4	Heated oxygen sensor (bank 1 sensor 1) (if equipped)	C51-2-8	Ground
		C51-2-9	Ground
C51-3-5	Heater of HO2S (bank 2 sensor 1) (if equipped)	C51-2-10	Ignition coil assembly for No.4
		C51-2-11	Ignition coil assembly for No.3
C51-3-6	Heater of HO2S (bank 1 sensor 1) (if equipped)	C51-2-12	Ignition coil assembly for No.2
		C51-2-13	Ignition coil assembly for No.1
C51-3-7	—	C51-2-14	IAC valve (stepper motor coil 2)
C51-3-8	Intake air temp. sensor	C51-2-15	IAC valve (stepper motor coil 1)
C51-3-9	Camshaft position sensor (POS)	C51-2-16	EGR valve (stepper motor coil 4)
C51-3-10	Camshaft position sensor (REF)	C51-2-17	EGR valve (stepper motor coil 3)
C51-3-11	Power source for TP sensor and MAP sensor	C51-2-18	Fuel injector No.4
		C51-2-19	Fuel injector No.3
C51-3-12	Throttle position sensor	C51-2-20	Power source
C51-3-13	Manifold absolute pressure sensor	C51-2-21	Power source
C51-3-14	Heated oxygen sensor (bank 1 sensor 2) (if equipped)	C51-2-22	Ignition coil assembly for No.6
		C51-2-23	Ignition coil assembly for No.5
C51-3-15	Heated oxygen sensor (bank 2 sensor 1) (if equipped)	C51-2-24	IAC valve (stepper motor coil 4)
		C51-2-25	IAC valve (stepper motor coil 3)
C51-3-16	Heater of HO2S (bank 2 sensor 2) (if equipped)	C51-2-26	Engine start signal
		C51-2-27	Fuel injector No.6
C51-3-17	Heater of HO2S (bank 1 sensor 2) (if equipped)	C51-2-28	Fuel injector No.5

## ENGINE &amp; EMISSION CONTROL INPUT/OUTPUT TABLE

Function	Input											Output										
	CMP sensor	MAF sensor	TP sensor	ECT sensor	IAT sensor	HO2S (Sensor 1)	CO adjusting resistor (if equipped)	VSS	Blower fan switch	Rear defogger switch	PSP switch	DLC	Diag. switch terminal (Vehicle with monitor connector)	Test switch terminal (Vehicle with monitor connector)	Ignition switch	Starter switch	ABS control module (if equipped)	A/C amplifier (if equipped)	TR switch (A/T VEHICLE)	Light switch	Stop lamp switch (A/T VEHICLE)	
Main relay control															○							
Fuel pump control	○														○	○						
Injection control	○	○	○	○		○	○									○	○					
Idle air control	○	○	○	○	○			○	○	○	○	○					○	○	○	○	○	○
Ignition control	○	○		○	○							○		○	○							
MIL control	○											○										
EVAP purge control	○	○	○	○				○														
EGR control	○	○	○	○	○			○				○										
HO2S heater control	○	○																				
A/C control	○		○	○												○		○				
A/C condensor fan control				○														○				

## ON-VEHICLE SERVICE

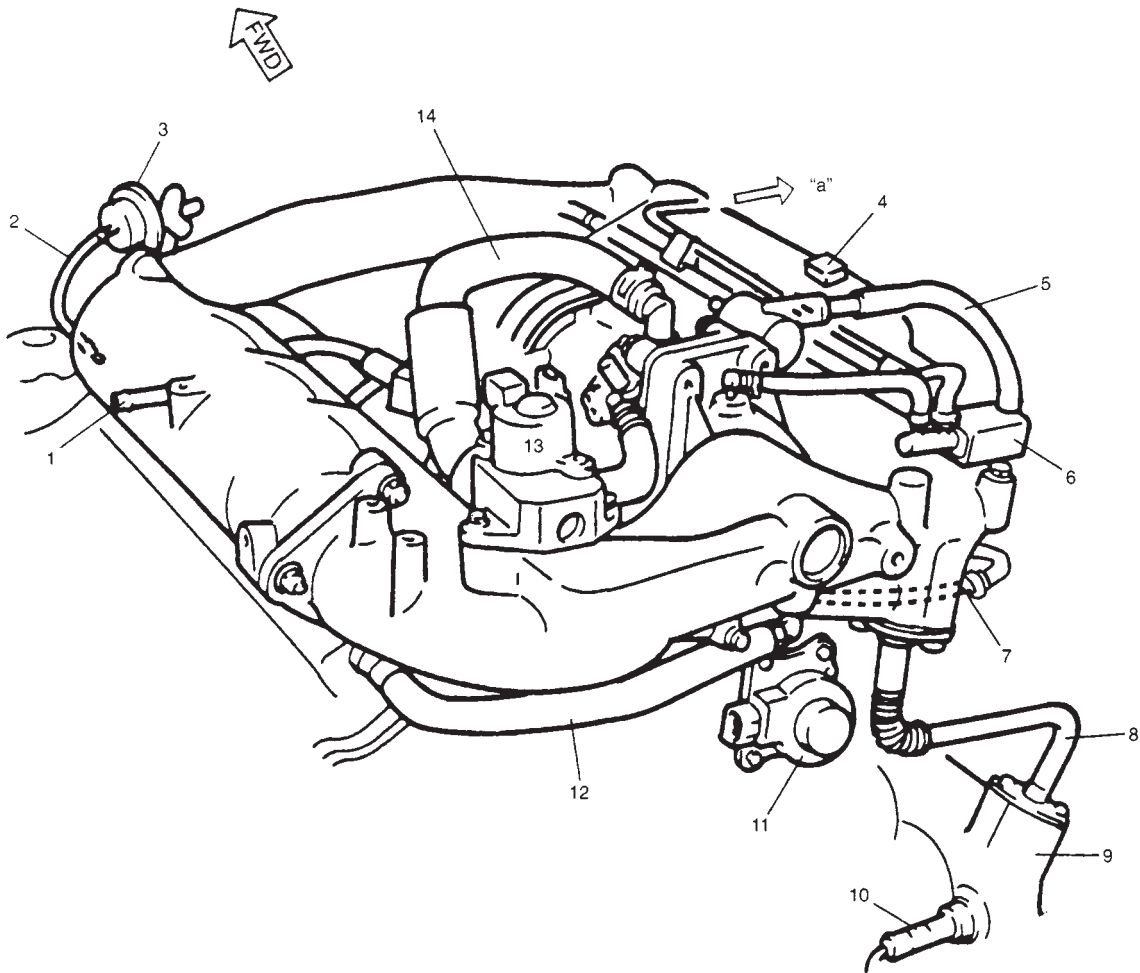

[A]

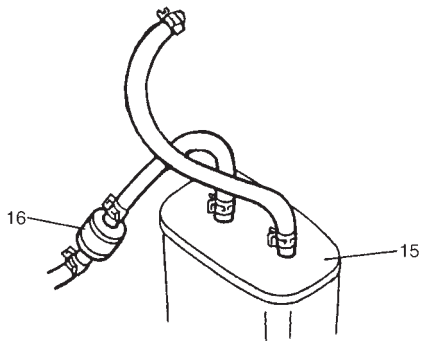

[B]

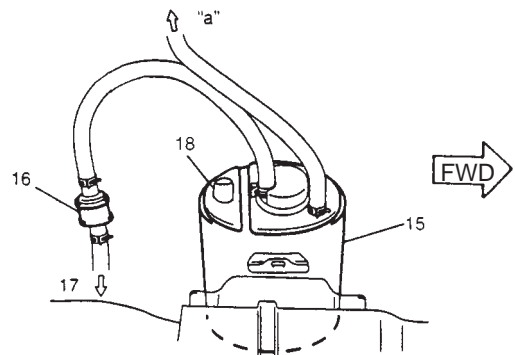

- 1. Brake booster hose pipe
- 2. Vacuum hose for fuel pressure regulator
- 3. Fuel pressure regulator
- 4. MAP sensor
- 5. Engine coolant hose
- 6. EVAP canister purge valve

- 7. Breather hose
- 8. EGR pipe
- 9. Exhaust manifold
- 10. Heated oxygen sensor
- 11. EGR valve
- 12. PCV hose

- 13. IAC valve
- 14. IAC hose
- 15. EVAP canister
- 16. Tank pressure control valve
- 17. Fuel tank
- 18. Air cap

[A]: Vehicle without immobilizer indicator lamp

[B]: Vehicle with immobilizer indicator lamp

## GENERAL

When hoses are disconnected and system components are removed for service, reinstall components properly, and route and connect hoses correctly after service. Refer to figure on previous page for proper routing of hoses.

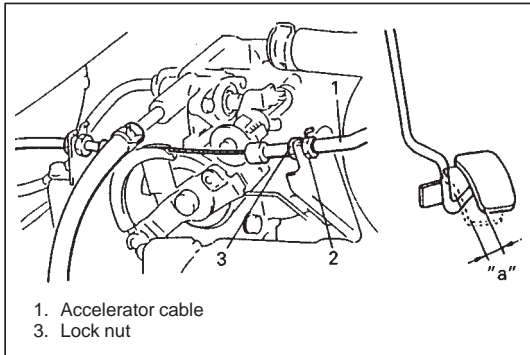

## ACCELERATOR CABLE ADJUSTMENT

- 1) Warm up engine to normal operating temperature. And check to make sure that fast idle control cam is off cam follower lever, if not check fast idle control system referring to "THROTTLE BODY INSPECTION" in this section.
- 2) With accelerator pedal depressed fully, check clearance between throttle lever and lever stopper (throttle body) which should be within following specification.

**Pedal play "a": 2 – 7 mm (0.08 – 0.27 in.)**

If measured value is out of specification, adjust it to specification with cable adjusting nut (2).

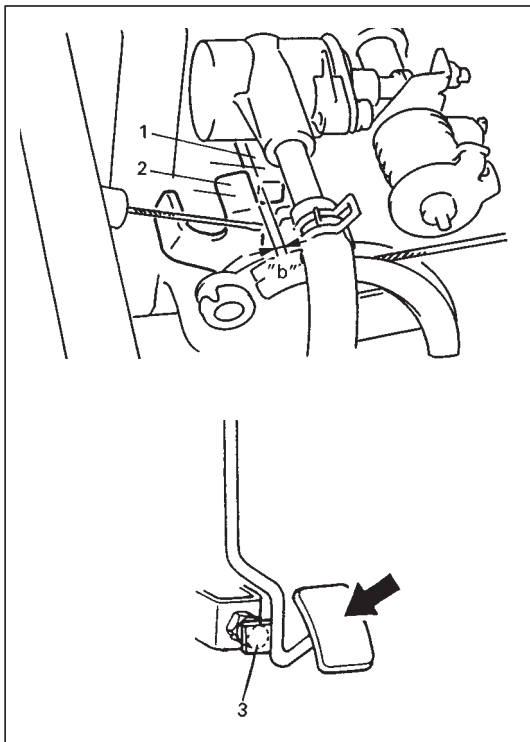

- 3) With accelerator pedal depressed fully, check clearance between throttle lever (2) and lever stopper (1) (throttle body) which should be within following specification.

**Clearance "b": 0.5 – 2.0 mm (0.02 – 0.07 in.)  
(With pedal depressed fully)**

If measured value is out of specification, adjust it to specification by changing height of pedal stopper bolt (3).

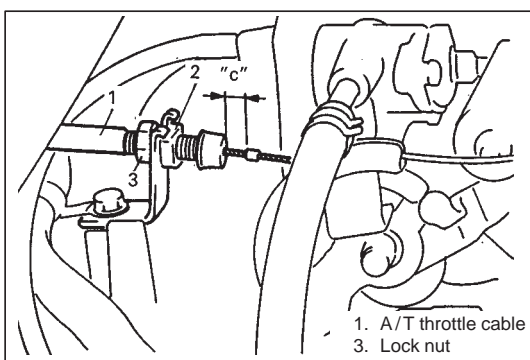

## A/T THROTTLE CABLE ADJUSTMENT (A/T VEHICLE)

- 1) Make sure that accelerator cable is adjusted as specified.
- 2) With throttle valve closed, check clearance "c" which should be within following specification.

**Clearance "c": 0.8 – 1.5 mm (0.03 – 0.06 in.)**

If it is out of specification, adjust it by turning cable adjusting nut (2).

**IDLE SPEED/IDLE AIR CONTROL (IAC) DUTY INSPECTION**

Before idle speed/IAC duty check, make sure of the following.

- Lead wires and hoses of engine/emission control systems are connected securely.
- Accelerator cable is adjusted.
- Ignition timing is within specification.
- All accessories (wipers, heater, lights, A/C, etc.) are out of service.
- Air cleaner has been properly installed and is in good condition.
- ECM (PCM) does not detect any malfunction DTC.

After above items are all confirmed, check idle speed and IAC duty as follows.

**NOTE:**

**Before starting engine, place transmission gear shift lever in “Neutral” (shift selector lever to “P” range for A/T vehicle), and set parking brake and block drive wheels.**

[Using SUZUKI scan tool, Tech 1]

- 1) Connect SUZUKI scan tool to DLC with ignition switch OFF.

**Special Tool**

**(A): SUZUKI scan tool, Tech 1**

**(B): Mass storage cartridge**

**(C): 16/14 pin DLC cable**

- 2) Warm up engine to normal operating temperature.
- 3) Check IAC duty and idle speed by using “Data List” mode of SUZUKI scan tool.

		A/C OFF	A/C ON
Engine idle speed:	without monitor connector	675 ± 50 r/min.	800 ± 50 r/min.
	with monitor connector	750 ± 50 r/min.	
IAC duty at specified idle speed:		10 – 50%	

If duty and/or idle speed is out of specifications, check idle air control system referring to Diagnostic Flow Table “DTC P0505 IDLE AIR CONTROL SYSTEM MALFUNCTION” in “ENGINE” section.

- 4) Check that specified engine idle speed is obtained with A/C ON if vehicle is equipped with A/C.  
If not, check A/C ON signal circuit and idle air control system.

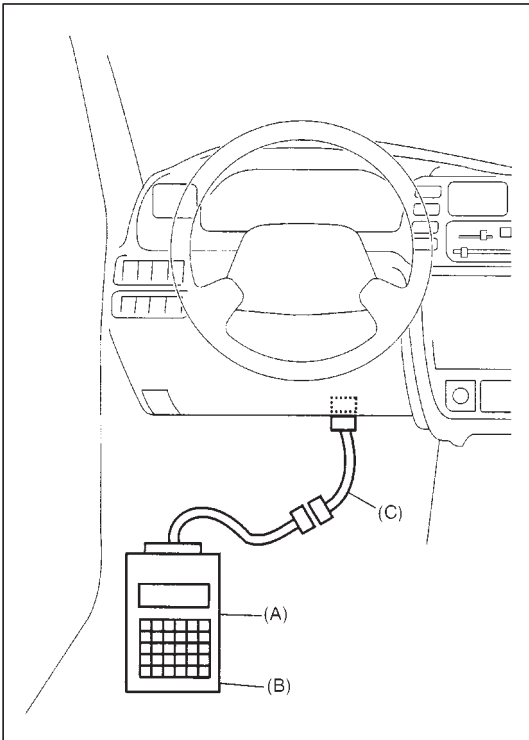

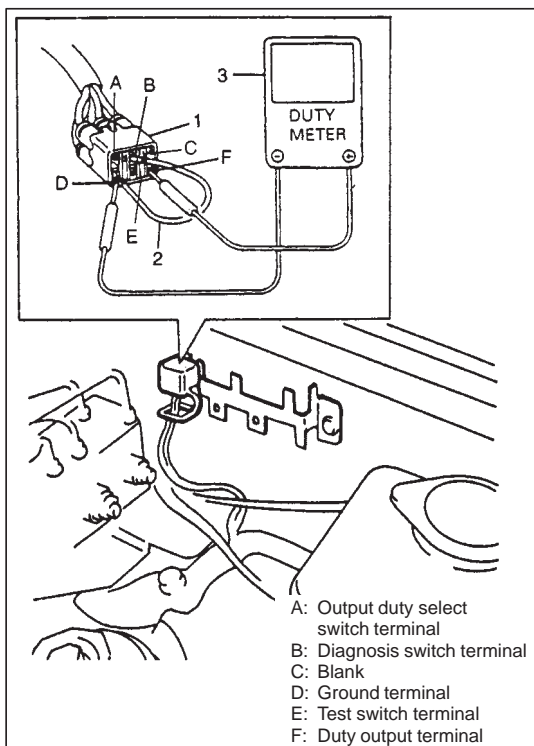

[Not using SUZUKI scan tool] (vehicle with monitor connector)

**NOTE:**

If ECM (PCM) parts No. ends with "0", ECM (PCM) does not output IAC duty through duty output terminal in monitor coupler. First of all, check label on ECM (PCM) for part No. if so, check IAC duty by using Tech 1.

- 1) Disconnect scan tool from DLC if connected.
- 2) Warm up engine to normal operating temperature.
- 3) Stop engine and connect duty meter (3) between duty output terminal and ground terminal of monitor connector (1).
- 4) Using service wire (2), ground diagnosis switch terminal in monitor connector.
- 5) Set tachometer.
- 6) Start engine and warm it up completely.
- 7) Check IAC duty and idle speed. If duty and/or idle speed is out of specifications, check idle air control system referring to Diagnostic Flow Table B-4 "IDLE AIR CONTROL SYSTEM CHECK" in this section.

	A/C OFF	A/C ON
Engine idle speed:	750 ± 50 r/min.	800 ± 50 r/min.
IAC duty at specified idle speed:	10 – 50% (1.4 – 7.0 V when battery voltage is 14 V)	—

**NOTE:**

IAC duty can be checked roughly by using voltmeter. IAC duty to voltage relation is as follows.

ON DUTY METER INDICATION (%)	OFF DUTY METER INDICATION (%)	VOLTMETER INDICATION (V)
0	100	0
50	50	0.5 x VB
100	0	VB

- "OFF DUTY METER" is such duty meter that indicates approx. 100% when terminal voltage is approx. "0 V".
- "VB" represents battery voltage while engine of vehicle being checked is running.

- 8) Remove service wire from monitor connector.
- 9) Install cap to monitor connector.
- 10) Check that specified engine idle speed is obtained with A/C ON if vehicle is equipped with A/C.  
 If not, check A/C ON signal circuit and idle air control system.

## IDLE MIXTURE INSPECTION/ADJUSTMENT (VEHICLE WITHOUT HEATED OXYGEN SENSOR)

All vehicles not equipped with heated oxygen sensor are shipped with their CO% factory adjusted as follows.

Engine idle mixture (CO%)	0.8 – 1.3% at specified idle speed
---------------------------	------------------------------------

Idle mixture adjustment should never be changed from the original factory setting. However, if during diagnosis, the check indicates idle mixture to be the cause of a driver performance complaint or emission failure, the idle mixture can be adjusted using the following procedures.

### NOTE:

**For this inspection and adjustment, exhaust gas tester (CO meter) and engine tachometer are necessary.**

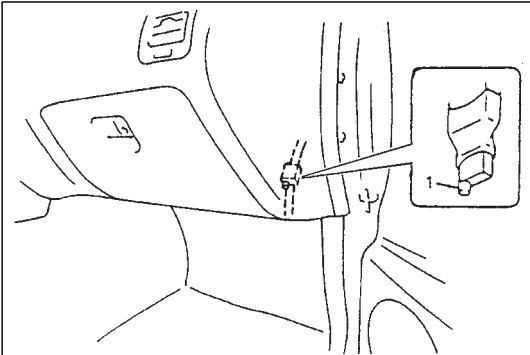

- 1) Check idle speed according to "IDLE SPEED/IDLE AIR CONTROL DUTY INSPECTION" section.
- 2) Using exhaust gas tester, check that idle mixture CO% is within above specification. If it is out of specification, adjust it to specification by turning resistor knob (1).
- 3) If idle mixture has been adjusted, confirm that idle speed/IAC duty is within specification.

## AIR INTAKE SYSTEM THROTTLE BODY

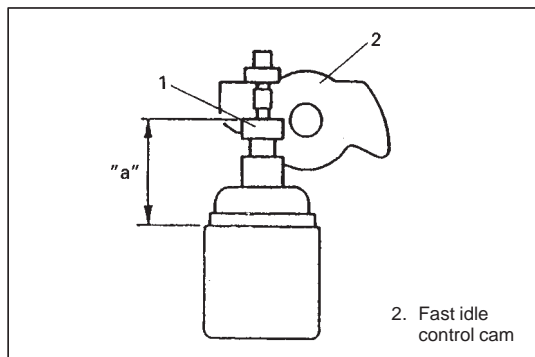
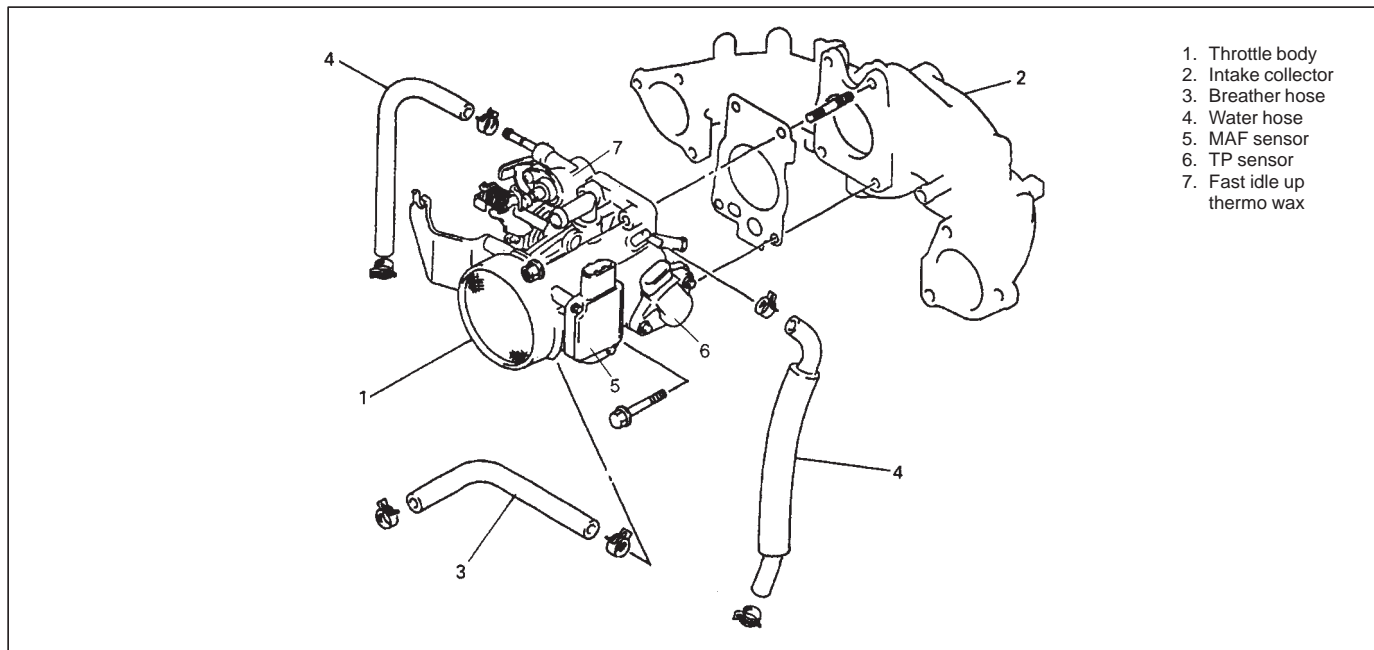

### On-Vehicle Inspection

- 1) Check that throttle valve lever moves smoothly.
- 2) Measure plunger (1) protrusion "a" at engine coolant temp. is 25°C (77°F).

**Plunger protrusion "a": 26.6 – 27.4 mm (1.048 – 1.078 in.)**

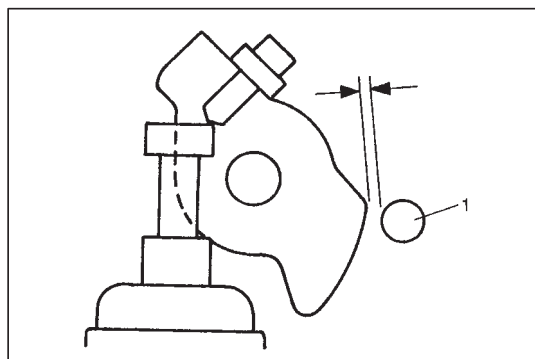

- 3) Warm up engine and check to make sure that fast control cam is off cam follower lever (1) at engine coolant temp. is 52 – 68°C (126 – 154°F).

If check result in step 2) or 3) is out of specification, replace throttle body assembly.

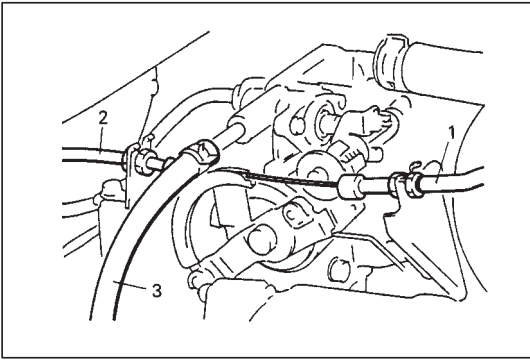

### Removal

- 1) Disconnect negative cable at battery.
- 2) Drain cooling system.
- 3) Remove strut tower bar.
- 4) Disconnect accelerator cable (1) and or A/T throttle cable (2) from throttle body.
- 5) Disconnect water hose (3) from throttle body.
- 6) Remove surge tank cover.

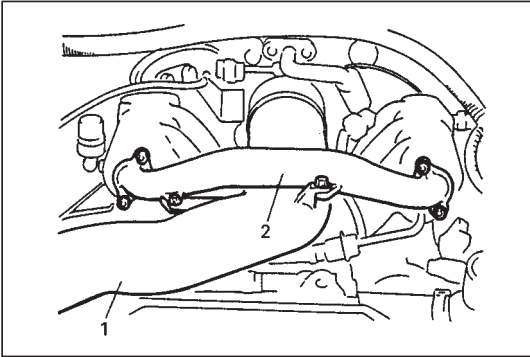

- 7) Remove intake air pipe (1) and surge tank pipe (2).

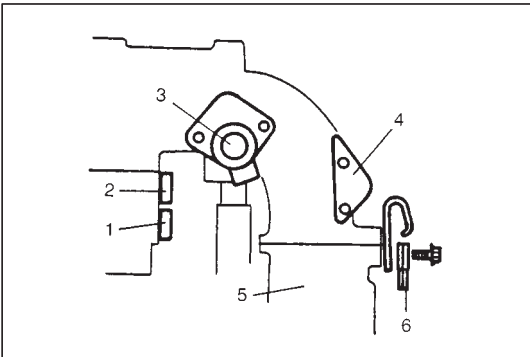

- 8) Disconnect connector of injector wire.
- 9) Disconnect connectors of TP sensor (2), MAF sensor (1) and IAC valve (3).
- 10) Disconnect ground terminal (6) from intake manifold (5).
- 11) Remove clamp bracket (4) from intake collector.

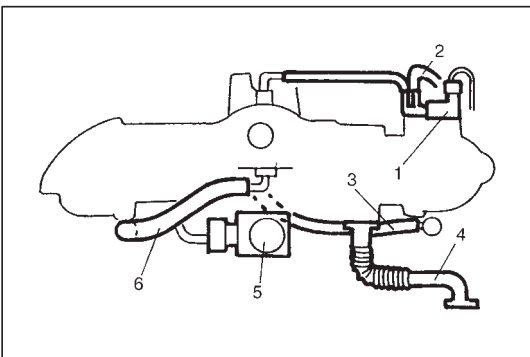

- 12) Disconnect connectors of EVAP canister purge valve (1) and EGR valve (5) (if equipped).
- 13) Disconnect PCV hose (6), breather hose (3) and EVAP canister purge valve hose (2).
- 14) Remove EGR pipe (4).

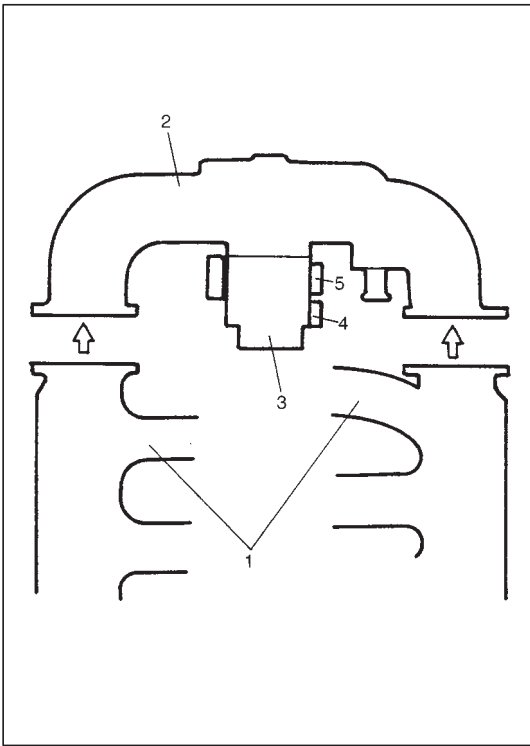

- 15) Remove throttle body (3) and intake collector (2) from intake manifold (1).
- 15) Disconnect hoses of IAC valve and PCV from throttle body.
- 16) Remove throttle body from intake collector.

**NOTE:**

- MAF sensor (4), TP sensor (5), or other components containing rubber must not be placed in a solvent or cleaner bath. A chemical reaction will cause these parts to swell, harden or get distorted.
- Don't put drills or wires into passages for cleaning. It causes damages in passages.

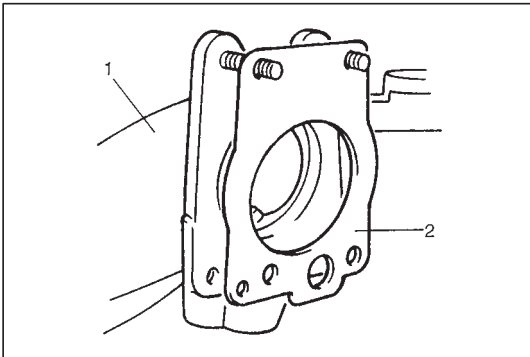
**Installation**

- 1) Clean mating surfaces and install throttle body gasket to intake collector (1) with new gasket (2).
- 2) Install throttle body to intake collector and tighten bolts.
- 3) Connect IAC valve hose and PCV hose.
- 4) Install throttle body and intake collector to intake manifold with new intake collector gaskets.
- 5) Install EGR pipe with new gaskets.
- 6) Connect PCV hose, breather hose and EVAP canister purge valve hose.
- 7) Connect connectors of EVAP canister purge valve and EGR valve.  
Fix wire harness with clamps.
- 8) Install clamp bracket to intake collector.
- 9) Connect ground terminal to intake manifold.
- 10) Connect connectors of TP sensor, MAF sensor and IAC valve.
- 11) Connect connector of injector wire.
- 12) Install surge tank pipe to intake manifold with new gaskets and intake air pipe to throttle body.
- 13) Install surge tank cover.
- 14) Connect engine coolant hoses to throttle body.
- 15) Connect accelerator cable and A/T throttle cable (A/T).
- 16) Install strut tower bar (1) and tighten bolts.
- 17) Refill cooling system.
- 18) Connect negative cable at battery.
- 19) Adjust accelerator cable and A/T throttle cable, refer to "ACCELERATOR CABLE ADJUSTMENT" and "A/T THROTTLE CABLE ADJUSTMENT" in this section.

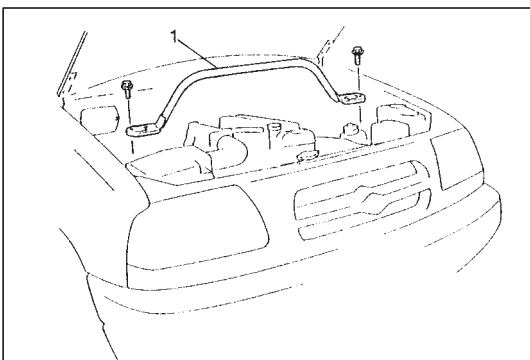

## IDLE AIR CONTROL VALVE (IAC VALVE)

### Removal

- 1) Disconnect battery negative cable at battery.
- 2) Disconnect IAC valve connector.
- 3) Remove IAC valve (1) from intake collector (2).

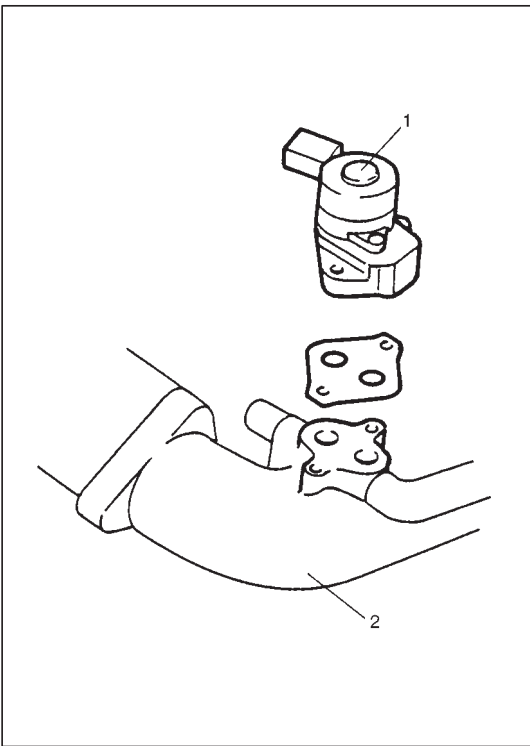

### On-Vehicle Inspection

- 1) Disconnect connector from IAC valve (1).
- 2) Check each coil of IAC valve for resistance.

Terminals	Resistance
Between "a" and "b"	20 – 24 $\Omega$ at 20°C, 68°F
"b" and "c"	
"d" and "e"	
"e" and "f"	

If resistances is out of specification, replace.

- 3) Remove IAC valve from intake collector.
- 4) Connect connector to IAC valve.
- 5) Check that plunger of IAC valve moves once and then stops as soon as ignition switch is turned OFF.

#### NOTE:

**This check should be performed by two people, one person operates ignition switch while the other checks plunger operation.**

If plunger of IAC valve does not operate at all, check wire harnesses for open and short. If wire harnesses are in good condition, replace IAC valve and recheck.

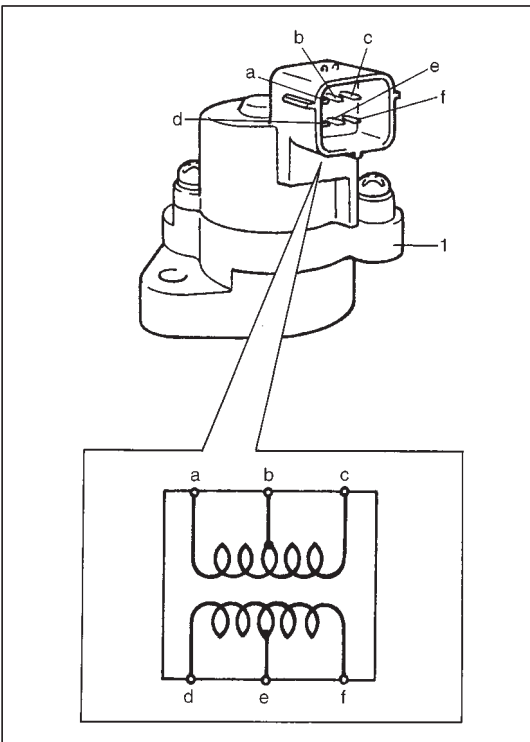

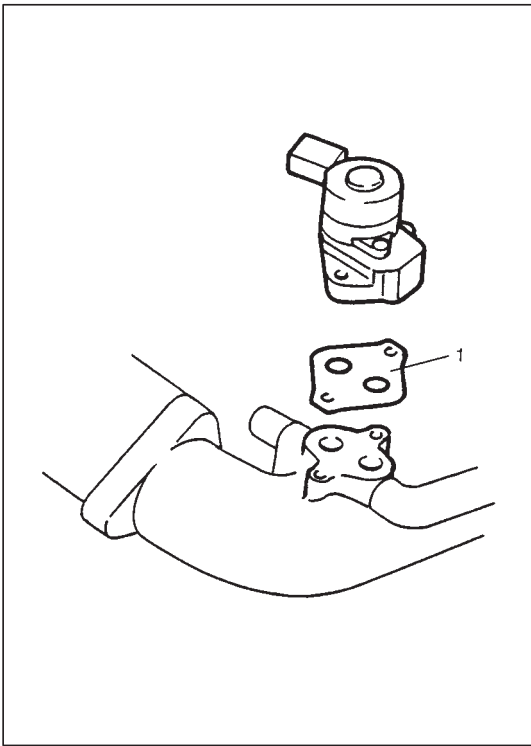

### Installation

For installation, reverse removal procedure and note following precautions.

- Use new gaskets (1).

## FUEL DELIVERY SYSTEM

### FUEL PRESSURE INSPECTION

- 1) Relieve fuel pressure in fuel feed line referring to "Fuel Pressure Relief Procedure" in "ENGINE GENERAL INFORMATION" section.
- 2) Disconnect fuel feed hose (3) from delivery fuel feed pipe (1).

#### CAUTION:

A small amount of fuel may be released when fuel feed hose is removed. Place container under the fuel feed hose or fuel feed pipe with a shop cloth so that released fuel is caught in container or absorbed in cloth. Place that cloth in an approved container.

- 3) Connect special tools and hose (2) between fuel feed hose and fuel feed pipe as shown in figure, and clamp hose securely to ensure no leaks occur during checking.

#### Special Tool

(A): 09912-58441

(B): 09912-58431

(C): 09912-58490

- 4) Check that battery voltage is above 11 V.

- 5) Turn ignition switch ON to operate fuel pump and after 3 seconds turn it OFF. Repeat this 3 or 4 times and then check fuel pressure.

- 6) Start engine.

- 7) Measure fuel pressure at idling.

If measure pressure doesn't satisfy specification, refer to "Diagnostic Flow Table B-3" and check each possibly defective part. Replace if found defective.

- 8) After checking fuel pressure, remove fuel pressure gauge.

#### CAUTION:

As fuel feed line is still under high fuel pressure, make sure to release fuel pressure according to following procedures.

- Place fuel container under joint.
- Cover joint with rag and loosen joint nut slowly to release fuel pressure gradually.

- 9) Remove fuel pressure gauge, hose and 3-way joint.

- 10) Connect fuel feed hose and clamp it securely.

- 11) With engine "OFF" and ignition switch "ON", check for fuel leaks.

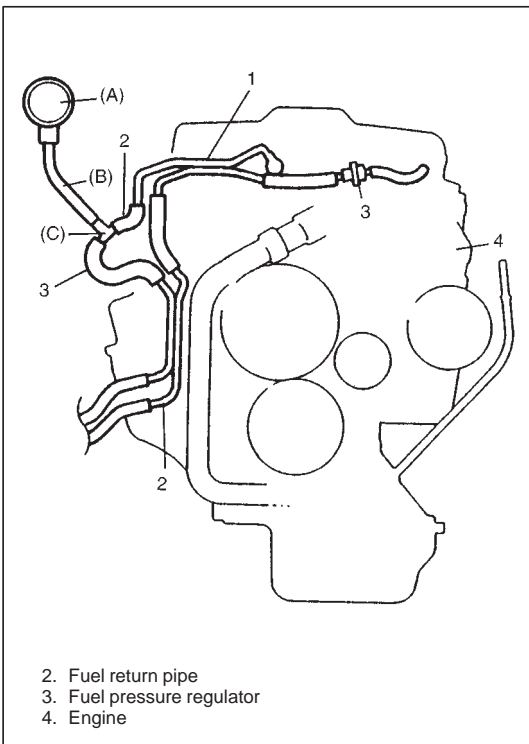

CONDITION	FUEL PRESSURE
With fuel pump operating and engine stopped	270 – 310 KPa 2.7 – 3.1 kg/cm <sup>2</sup> 38.4 – 44.0 psi
At specified idle speed	210 – 260 KPa 2.1 – 2.6 kg/cm <sup>2</sup> 29.8 – 37.0 psi
With 1 min. after engine (fuel pump) stopped (Pressure reduces as time passes)	over 200 kPa 2.0 kg/cm <sup>2</sup> 28.4 psi

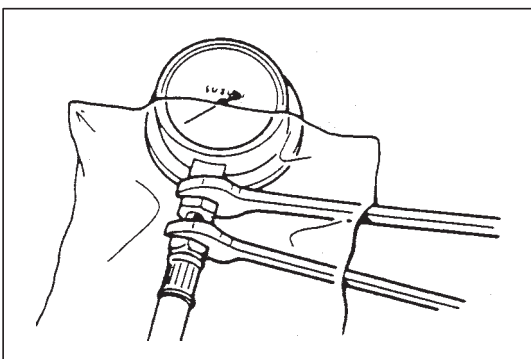

## FUEL PUMP

### On-Vehicle Inspection

#### CAUTION:

When fuel filler cap is removed in any procedure, work must be done in a well-ventilated area, keep away from any open flames and without smoking.

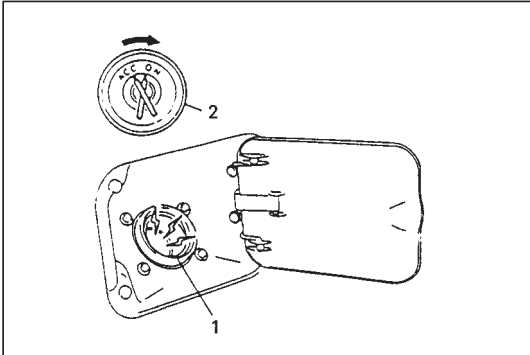

- 1) Remove filler cap and turn ON ignition switch (2). Then fuel pump operating sound should be heard from fuel filler (1) for about 3 seconds and stop. Be sure to reinstall fuel filler cap after checking.

If above check result is not satisfactory, advance to "Diagnostic Flow Table B-1" in "ENGINE" section.

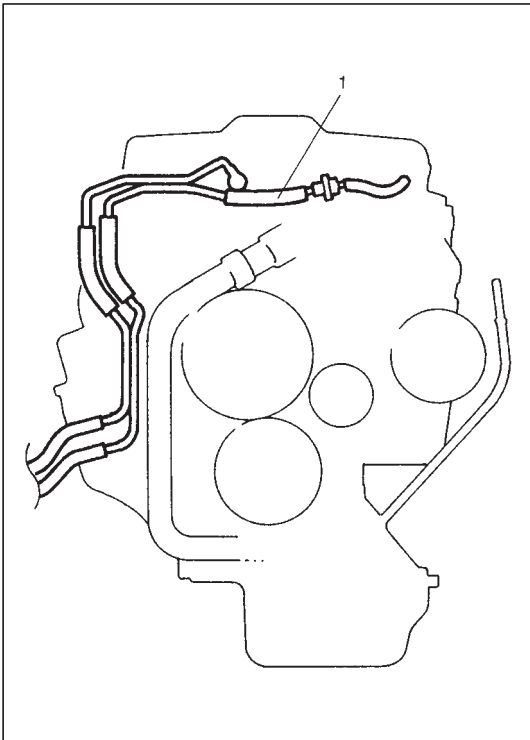

- 2) Fuel pressure should be felt at fuel return hose (1) for 3 seconds after ignition switch ON.

If fuel pressure is not felt, advance to "Diagnostic Flow Table B-3" in "ENGINE" section.

### Removal

- 1) Remove fuel tank from body according to procedure described in Section 6C and remove fuel pump from fuel tank.

### Inspection

Check fuel pump filter for evidence of dirt and contamination. If present, clean and check for presence of dirt in fuel tank.

### Installation

- 1) Install fuel pump to fuel tank and then install fuel tank to body according to procedure described in "ENGINE FUEL" section.

## FUEL PRESSURE REGULATOR

### Removal

- 1) Relieve fuel pressure in fuel feed line referring to "Fuel Pressure Relief Procedure" in "ENGINE" section.
- 2) Disconnect battery negative cable from battery.
- 3) Disconnect vacuum hose (1) from fuel pressure regulator.

- 4) Remove fuel pressure regulator (1) from fuel delivery pipe (3).

#### CAUTION:

A small amount of fuel may be released when it is from delivery pipe.  
Place a shop cloth under delivery pipe so that released fuel is absorbed in it.

- 5) Disconnect fuel return hose (2) from fuel pressure regulator.

#### CAUTION:

A small amount of fuel may be released when hose is disconnected. Cover hose to be disconnected with a shop cloth.

### Installation

For installation, reverse removal procedure and note following precautions.

- Use new O-ring.
- Apply thin coat of gasoline to O-ring to facilitate installation.

- Tighten fuel pressure regulator (1) bolts to specified torque.

#### Tightening Torque

(a): 10 N·m (1.0 kg·m, 7.5 lb-ft)

- With engine "OFF" and ignition switch "ON", check for fuel leaks around fuel line connection.

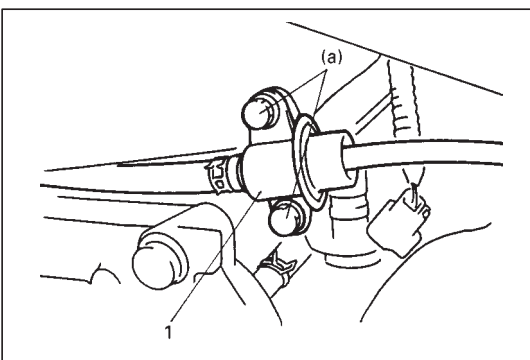
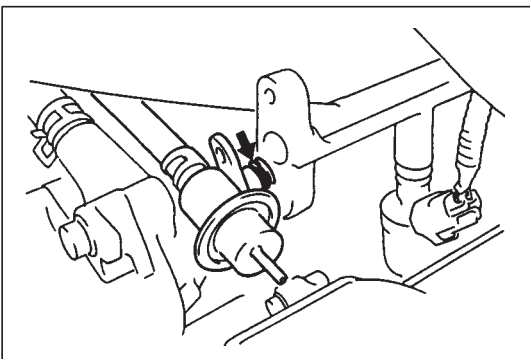
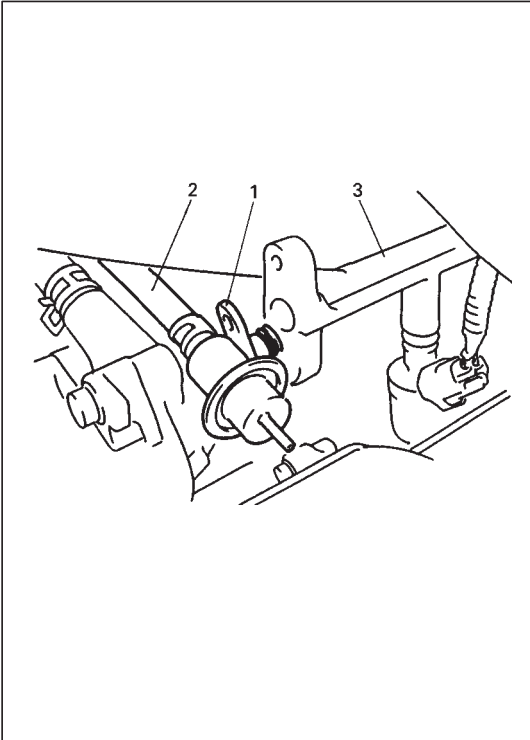
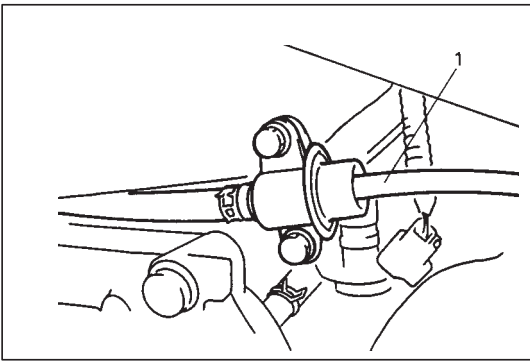

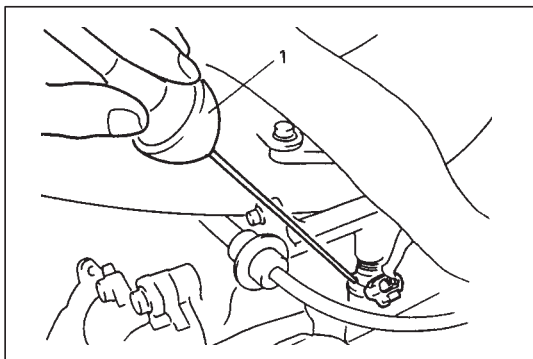

## FUEL INJECTOR

### On-Vehicle Inspection

- 1) Using sound scope (1) or such, check operating sound of injector when engine is running or cranking.  
Cycle of operating sound should vary according to engine speed.  
If no sound or an unusual sound is heard, check injector circuit (wire or coupler) or injector.

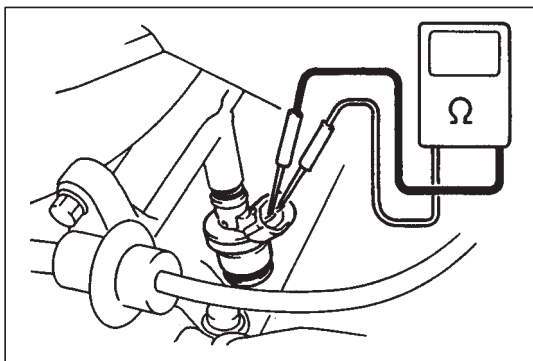

- 2) Disconnect connector from injector, connect ohmmeter between terminals of injector and check resistance.

**Resistance of injector: 10 – 14  $\Omega$  at 20°C (68°F)**

If resistance is out of specification, replace.

- 3) Connect connector to injector securely.

### Removal

- 1) Relieve fuel pressure in fuel feed line referring to “Fuel Pressure Relief Procedure” in “ENGINE” section.
- 2) Remove throttle body intake collector, refer to “THROTTLE BODY REMOVAL” in this section.

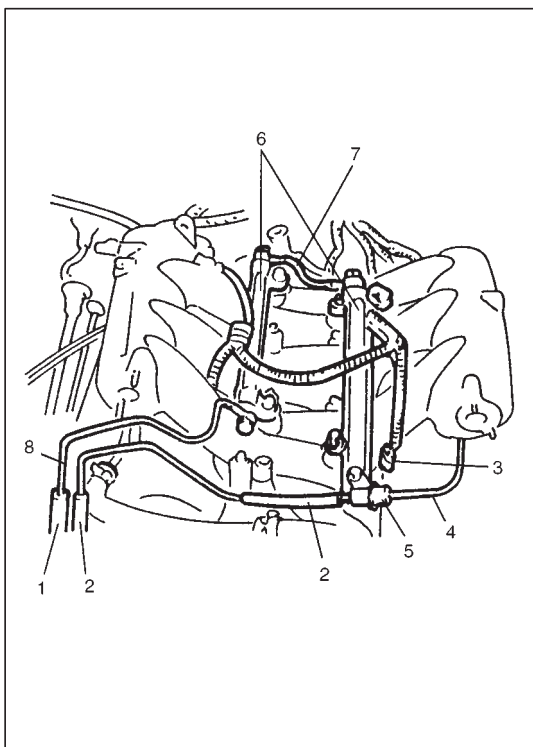

- 3) Disconnect fuel feed hose (1) and fuel return hose (2).
- 4) Disconnect vacuum hose (4) and fuel return hose from fuel pressure regulator (5).
- 5) Remove fuel feed pipe (8) and fuel connect pipe (7) from delivery pipes (6) (right and left).

#### CAUTION:

**A small amount of fuel may be released when it is from delivery pipe.**

**Place a shop cloth under delivery pipe so that released fuel is absorbed in it.**

- 6) Disconnect connector (3) from each injector.

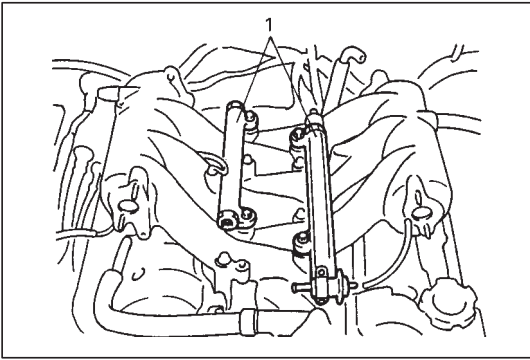

- 7) Remove delivery pipes (1) (right and left) from intake manifold.
- 8) Remove fuel injector(s).

### Inspection

#### **WARNING:**

**As fuel is injected in this inspection, perform in a well ventilated area and away from open flames.**

**Use special care to prevent sparking when connecting and disconnecting test lead to and from battery.**

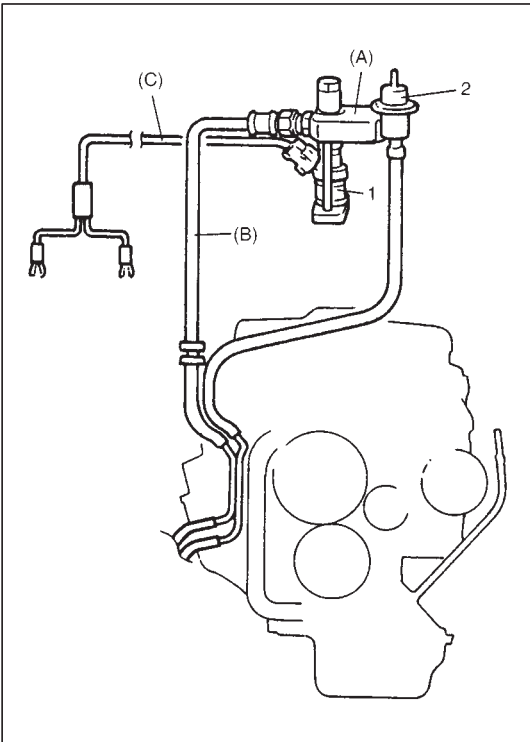

- 1) Install injector (1) and fuel pressure regulator (2) to special tool (injector checking tool).

#### **NOTE:**

**Remove grommet from injector, then install injector to special tool and tighten bolts by hand.**

#### **Special Tool**

**(A): 09912-58421**

- 2) Connect special tools (hoses and attachment) to pipes of vehicle.

#### **Special Tool**

**(B): 09912-58431**

- 3) Connect special tool (test lead) to injector.

#### **Special Tool**

**(C): 09930-88521**

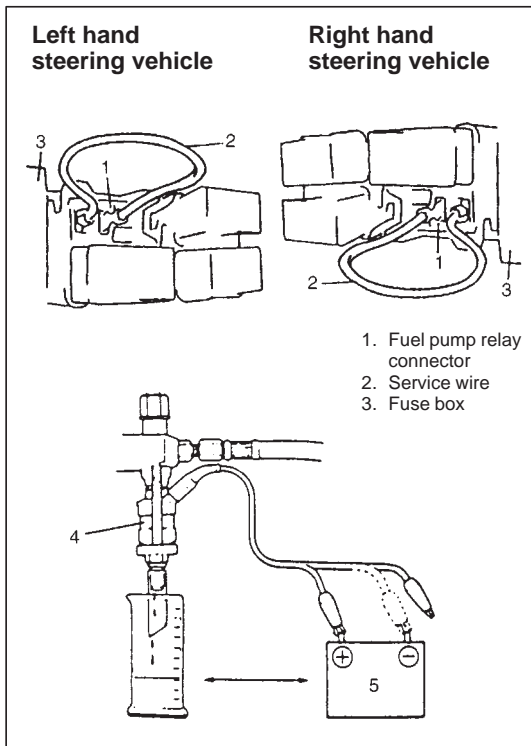

- 4) Install suitable vinyl tube onto injector (4) nozzle to prevent fuel from splashing out when injecting.
- 5) Put graduated cylinder under injector as far apart as possible.
- 6) Disconnect fuel pump relay.
- 7) To operate fuel pump and apply fuel pressure to injector, using wire harness as thick as the one used for fuel pump circuit, connect two terminals of relay connector as shown in figure.
- 8) Apply battery (5) voltage to injector for 15 seconds and measure injected fuel volume with graduated cylinder.  
Test each injector two or three times.  
If not within specification, replace injector.

**Injected fuel volume:**

**64 – 70 cc/15 sec. (2.16/2.25 – 2.37/2.47 US/Imp. oz/15 sec.)**

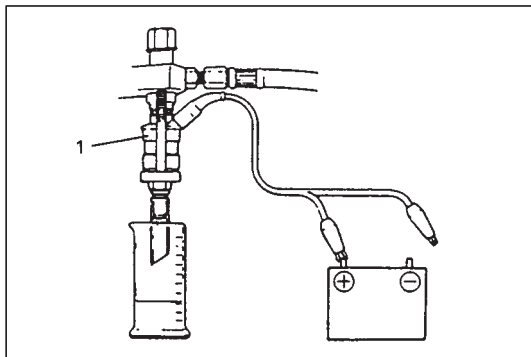

- 9) Check fuel leakage from injector (1) nozzle. Do not operate injector for this check (but fuel pump should be at work). If fuel leaks more than following specifications, replace.

**Fuel leakage: Less than 1 drop/min.**

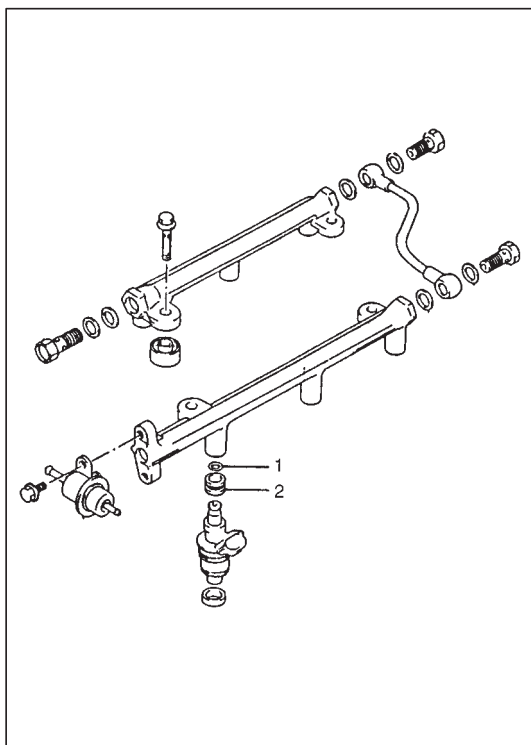

**Installation**

- 1) Replace injector O-ring (1) with new one using care not to damage it. Install grommet (2) to injector.

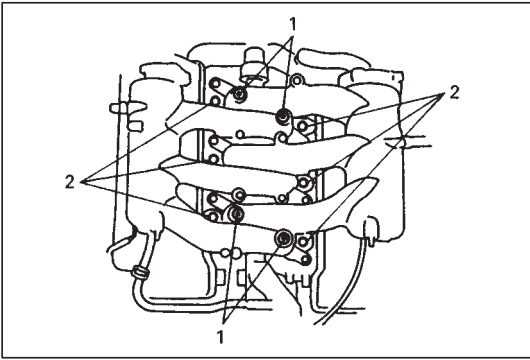

- 2) Check if insulator (1) is scored or damaged. If it is, replace with new one.  
Install insulators and cushions (2) to intake manifold.

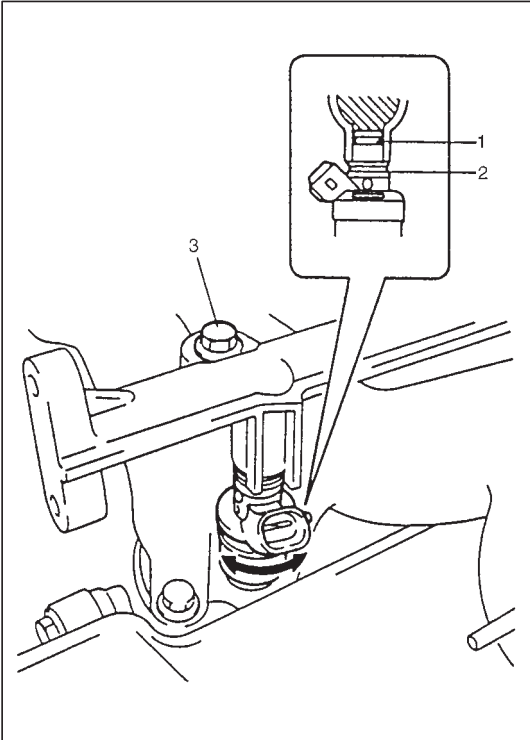

- 3) Apply thin coat of fuel to O-rings (1) and then install injectors into delivery pipes (right and left) and intake manifold.  
Make sure that injectors rotate smoothly. If not, probable cause is incorrect installation of O-ring or grommet (2). Replace O-ring with new one.
- 4) Tighten delivery pipe bolts (3) and make sure that injectors rotate smoothly.

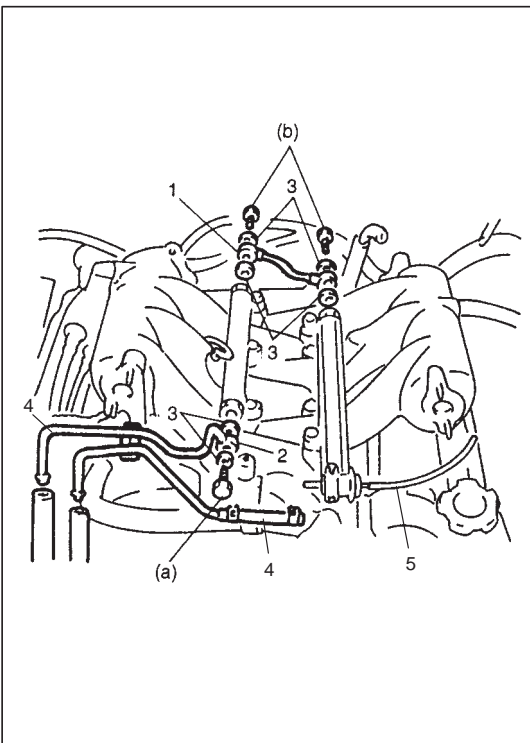

- 5) Install fuel connect pipe (1) and tighten union bolts to specified torque with new gaskets (3).

#### **Tightening Torque**

**(b): 30 N·m (3.0 kg-m, 22.0 lb-ft)**

- 6) Install fuel feed pipe (2) and tighten union bolt to specified torque with new gaskets.

#### **Tightening Torque**

**(a): 30 N·m (3.0 kg-m, 22.0 lb-ft)**

- 7) Connect vacuum hose (5) and fuel return hose (4) to fuel pressure regulator.

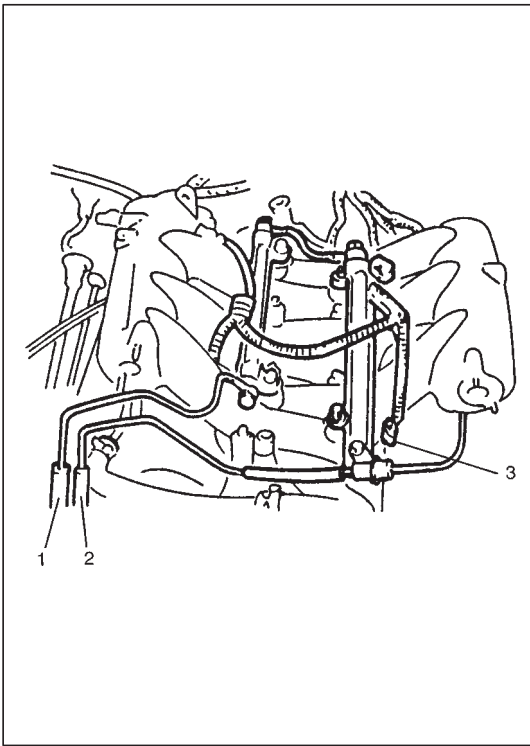

- 8) Connect fuel feed hose (1) and fuel return hose (2).
- 9) Connect connectors (3) to injectors.
- 10) Install throttle body and intake collector, refer to "THROTTLE BODY INSTALLATION" in this section.
- 11) With engine "OFF" and ignition switch "ON", check for fuel leaks around fuel line connection.

## ELECTRONIC CONTROL SYSTEM

### ENGINE CONTROL MODULE (ECM)/POWERTRAIN CONTROL MODULE (PCM)

#### CAUTION:

As ECM (PCM) consists of precision parts, be careful not to expose it to excessive shock.

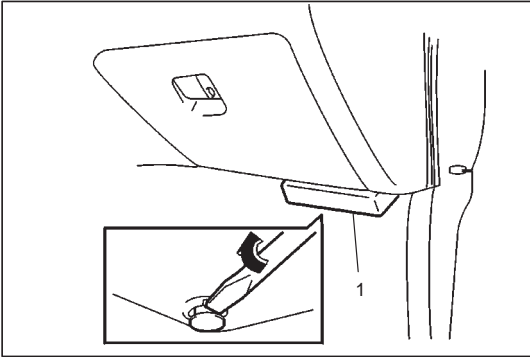

#### Removal

- 1) Disconnect battery negative cable from battery.
- 2) Disable air bag system (if equipped) referring to "Disabling the Air Bag System" in Air Bag System section.
- 3) Remove ECM (PCM) cover (1) from bracket.

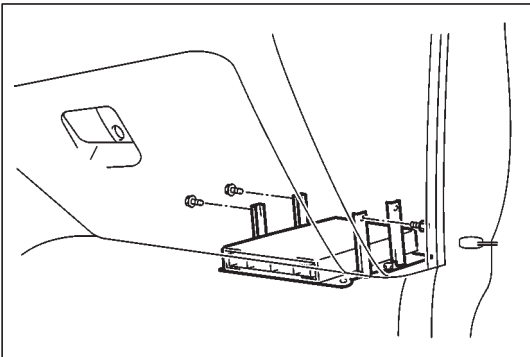

- 4) Disconnect connectors from ECM (PCM).
- 5) Remove ECM (PCM) with bracket.

#### Installation

- 1) Install ECM (PCM) with bracket to vehicle.
- 2) Connect connectors to ECM (PCM) securely.
- 3) Install ECM (PCM) cover to bracket.
- 4) Enable air bag system (if equipped) referring to "Enabling Air Bag System" in Air Bag system section.
- 5) Connect negative cable to battery.

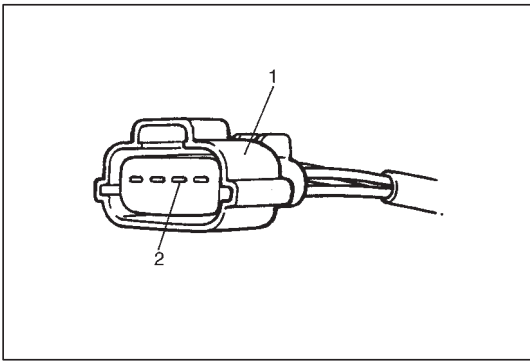

## MASS AIR FLOW SENSOR (MAF SENSOR)

### Inspection

#### NOTE:

Use voltmeter with high-impedance (10 k $\Omega$ /V minimum) or digital type voltmeter.

- 1) Remove ECM (PCM) cover from bracket.
- 2) With ignition switch OFF, disconnect MAF sensor connector (1).
- 3) Connect voltmeter to C32-3 terminal (2) of MAF sensor connector disconnected and ground.
- 4) Turn ignition switch ON and check that voltage is battery voltage.  
If not, check if wire harness is open or connection is poor.
- 5) Turn ignition switch OFF and connect MAF sensor connector to MAF sensor.

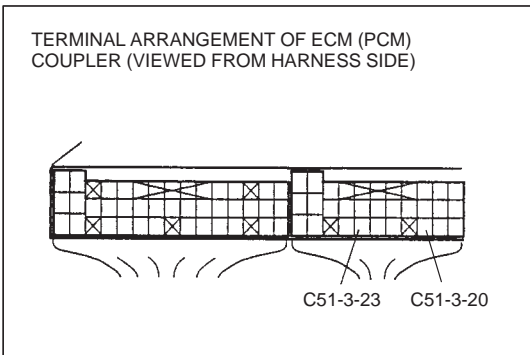

- 6) Turn ignition switch ON and check voltage between C51-3-23 and C51-3-20 terminal.

**Standard voltage: 0.5 – 1.0 V**

- 7) Start engine and check that voltage is lower than 5V and it rises as engine speed increases.  
(Reference data: 1.5 – 1.8 V at specified idle speed)

If check result is not as specified above, cause may lie in wire harness, coupler connection, MAF sensor or ECM (PCM).

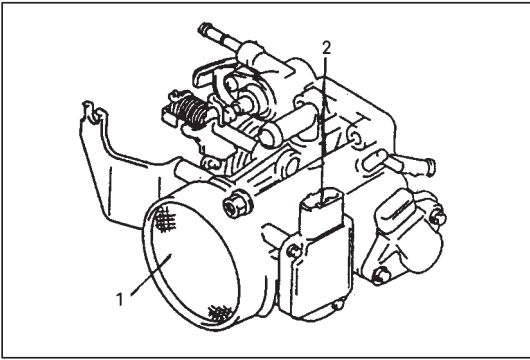

### Removal

- 1) Disconnect negative cable at battery and coupler from MAF sensor (2).
- 2) Remove throttle body (1), referring to "THROTTLE BODY REMOVAL" in this section.

### NOTE:

**Don't remove MAF sensor.**

### CAUTION:

- Do not expose MAF sensor (throttle body) to any shock.
- Do not blow compressed air by using air gun or the like.
- Do not put finger or any other object into MAF sensor and keep away from net. Malfunction may occur.

### Installation

- 1) Install throttle body, referring to "THROTTLE BODY INSTALLATION" in this section.

## INTAKE AIR TEMPERATURE (IAT) SENSOR

### Removal

- 1) Disconnect negative cable from battery.
- 2) Disconnect IAT sensor coupler.
- 3) Remove IAT sensor from air cleaner case.

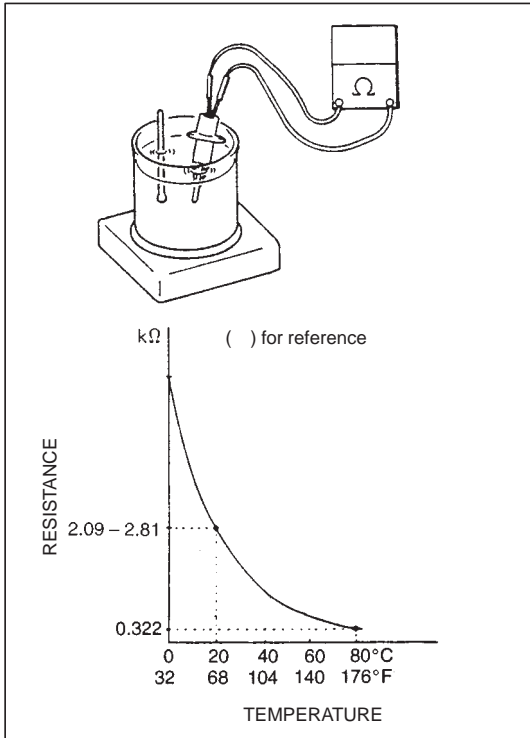

### Inspection

Immerse temperature sensing part of IAT sensor in water (or ice) and measure resistance between sensor terminals while heating water gradually.

If measured resistance doesn't show such characteristic as shown in figure, replace IAT sensor.

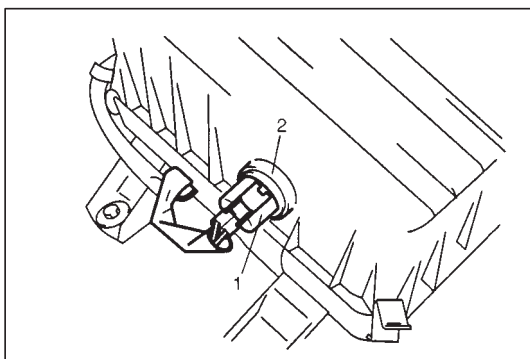

### Installation

- 1) Clean mating surface of sensor and seal on air cleaner case.
- 2) Install IAT sensor (1) into seal (2).
- 3) Connect connector to IAT sensor securely.

## THROTTLE POSITION SENSOR (TP SENSOR)

### Inspection

- 1) Warm up engine and stop it when its temperature has reached normal operating temperature (Check to make sure that they have some clearance between fast idle cam and cam follow lever.).
- 2) Disconnect negative cable at battery and coupler from TP sensor.
- 3) Using ohmmeter, check resistance between terminals under each condition given in table below.

TERMINALS	RESISTANCE
Between 1 and 3 terminals	4 – 6 k $\Omega$
Between 2 and 3 terminals	0 – 4.6 k $\Omega$ , varying linearly according to throttle valve opening

If check result is not satisfactory, replace TP sensor.

- 4) Connect TP sensor coupler securely.
- 5) Connect negative cable to battery.

### Removal

- 1) Disconnect battery negative cable at battery.
- 2) Disconnect connector from TP sensor.
- 3) Remove TP sensor from throttle body.

### Installation

- 1) To install sensor, place it onto throttle body so that sensor pickup lever (2) can engage with throttle body lever (1). A should engage with B.
- 2) Hand-tighten TP sensor screws.

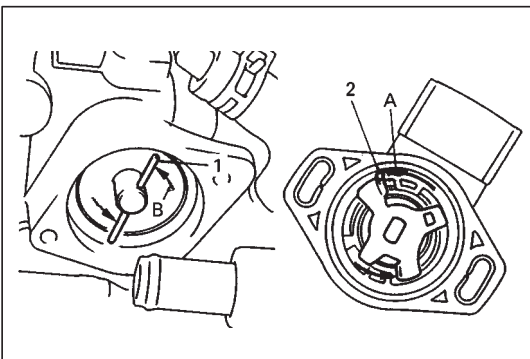
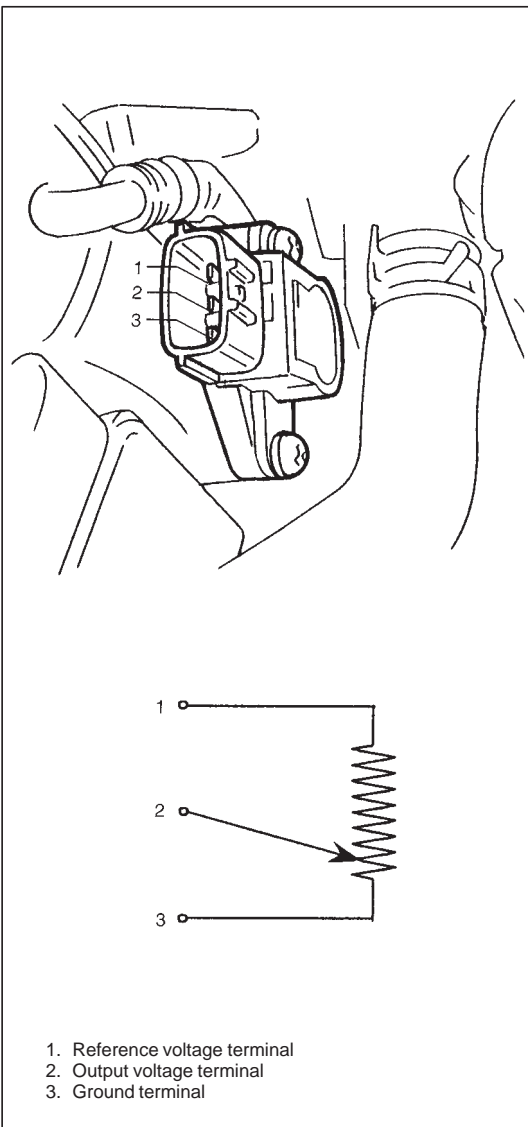

- 3) Connect connector to TP sensor securely.
- 4) Connect battery negative cable to battery.
- 5) Adjust installation angle of TP sensor according to procedure described in item "Adjustment".

### Adjustment

- 1) Warm up engine to normal operating temperature.
- 2) Check to make sure that fast idle cam and cam follower lever are not in contact with each other. If they are, check fast idle control system.

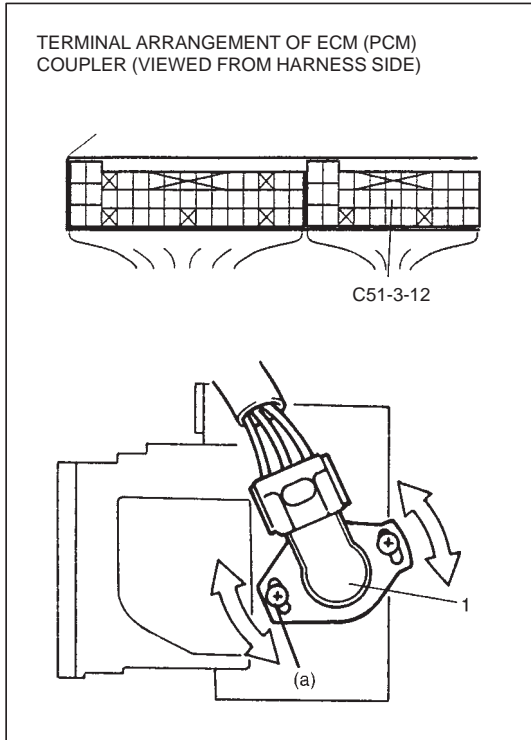

- 3) Loosen TP sensor screws.
- 4) Remove ECM (PCM) cover from bracket.
- 5) Turn TP sensor (1) clockwise or counterclockwise and tighten TP sensor screw at a position where voltage as specified below is obtained at coupler terminal C51-3-12.

#### NOTE:

**If tech 1 and cartridge are available, make an adjustment by using tech 1 while observing TP sensor voltage.**

**TP sensor voltage when throttle is fully close:  $0.50 \pm 0.15$  [V]**

#### Tightening Torque

**(a):  $2.5$  N·m ( $0.25$  kg-m,  $1.8$  lb-ft)**

- 6) Check to make sure that when throttle is fully open TP sensor voltage is as shown below.

**TP sensor voltage when throttle is fully open:  $4.0 \pm 0.5$  [V]**

- 7) Install ECM (PCM) cover.
- 8) Disconnect negative cable at battery for 30 sec. or more and connect negative cable at battery.

## ENGINE COOLANT TEMPERATURE SENSOR (ECT SENSOR)

### Removal

- 1) Disconnect negative cable from battery.
- 2) Drain cooling system.
- 3) Disconnect coupler from ECT sensor (1).
- 4) Remove ECT sensor from water outlet cap (2).

### Inspection

Immerse temperature sensing part of ECT sensor in water and measure resistance between sensor terminals while heating water gradually.

If measured resistance doesn't shown such characteristic as shown, replace ECT sensor.

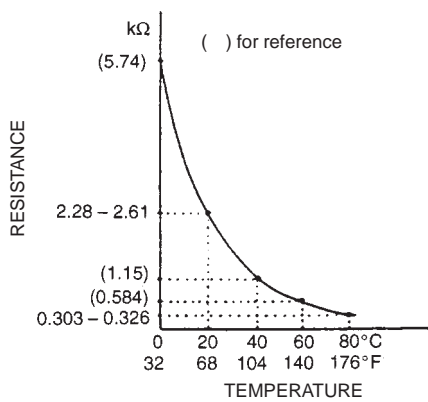
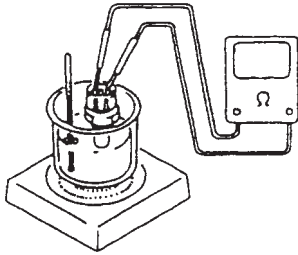

### Installation

Reverse removal procedure noting the following.

- Clean mating surfaces of sensor and water outlet cap (1).
- Use new O-ring.
- Tighten ECT sensor to specified torque.

#### Tightening Torque

(a): 15 N·m (1.5 kg·m, 11.0 lb·ft)

- Connect coupler to sensor securely.
- Refill cooling system.

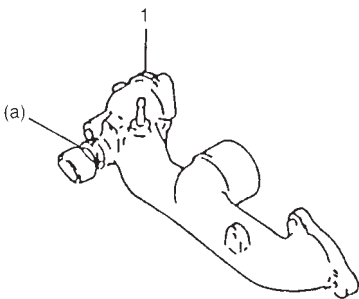

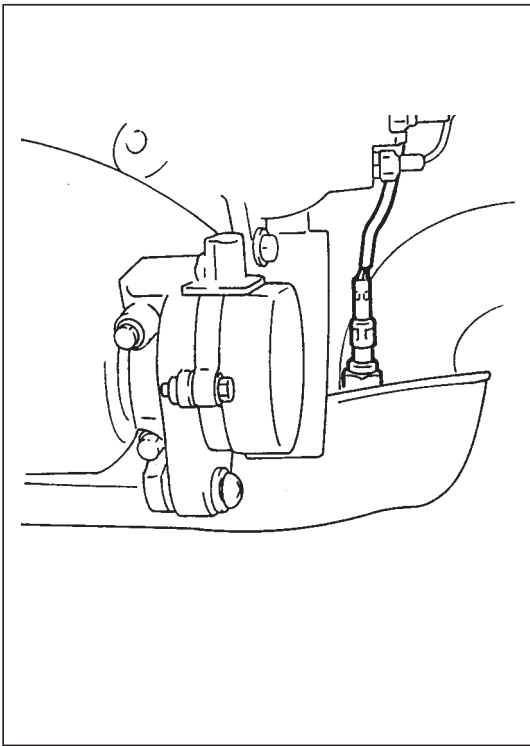

## HEATED OXYGEN SENSOR (SENSOR 1)

### Removal

#### WARNING:

To avoid danger of being burned, do not touch exhaust system when system is hot. Oxygen sensor removal should be performed when system is cool.

- 1) Disconnect negative cable from battery.
- 2) Disconnect coupler of oxygen sensor(s).
- 3) Remove oxygen sensor(s) from exhaust manifold(s).

#### NOTE:

Be careful not to expose it to excessive shock.

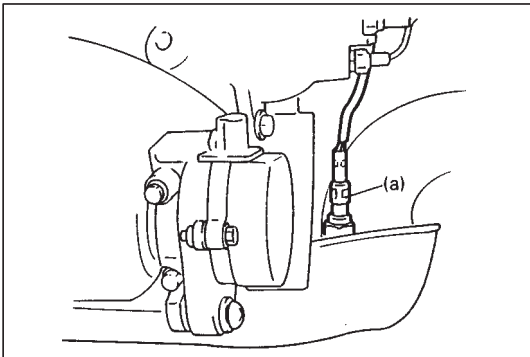

### Installation

Reverse removal procedure noting the followings.

- Tighten oxygen sensor(s) to specified torque.

#### Tightening Torque

**(a): 45 N·m (4.5 kg-m, 32.5 lb-ft)**

- Connect connector of oxygen sensor(s) and clamp wire harness securely.
- After installing oxygen sensor(s), start engine and check that no exhaust gas leakage exists.

**HEATED OXYGEN SENSOR (SENSOR 2)****Removal****WARNING:**

To avoid danger of being burned, do not touch exhaust system when system is hot. Oxygen sensor removal should be performed when system is cool.

- 1) Disconnect negative cable from battery.
- 2) Disconnect coupler of oxygen sensor(s).
- 3) Remove oxygen sensor(s) (2) from exhaust No.1 pipe (1).

**NOTE:**

Be careful not to expose it to excessive shock.

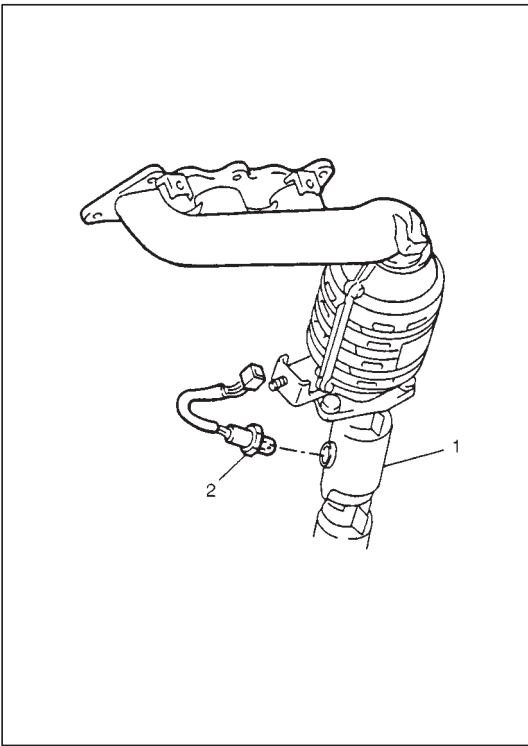
**Installation**

Reverse removal procedure noting the followings.

- Tighten oxygen sensor(s) to specified torque.

**Tightening Torque**

(a): 45 N·m (4.5 kg·m, 32.5 lb-ft)

- Connect connector of oxygen sensor(s) and clamp wire harness securely.
- After installing oxygen sensor(s), start engine and check that no exhaust gas leakage exists.

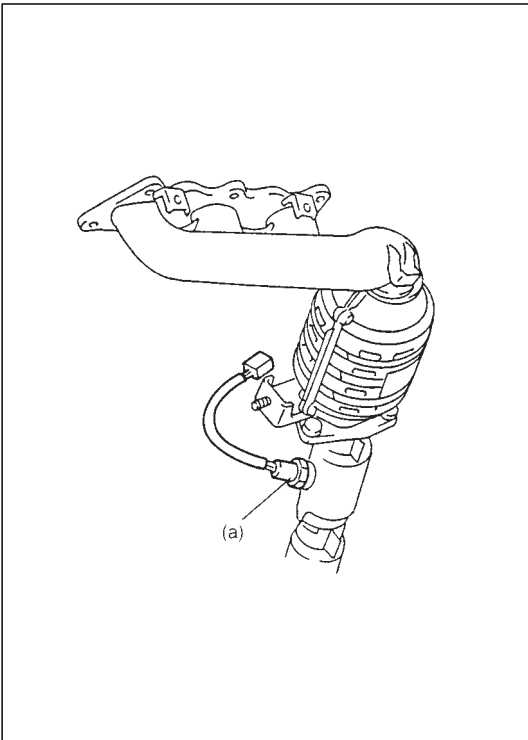

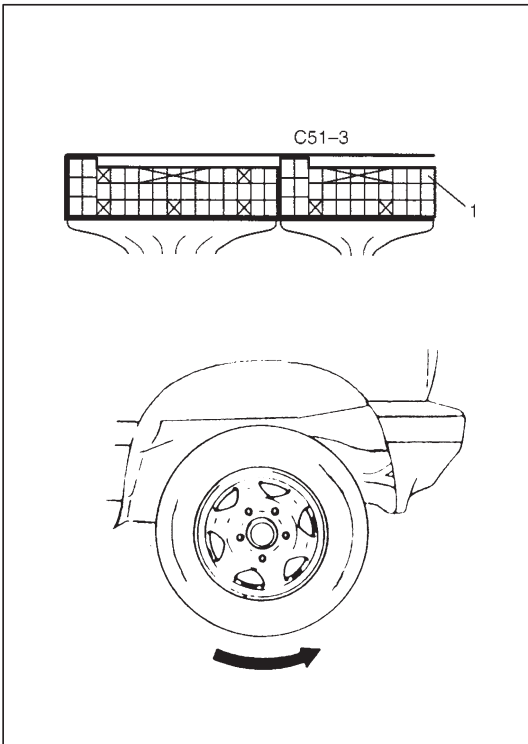

## VEHICLE SPEED SENSOR (VSS)

### On-Vehicle Inspection

- 1) Hoist vehicle.
- 2) Release parking brake lever, set transmission in neutral and transfer in "2H".
- 3) Remove ECM (PCM) cover.
- 4) Connector voltmeter between VSS terminal C51-3-1 of ECM (PCM) connector and body ground.
- 5) Turn ignition switch ON and turn rear right tire slowly with rear left tire locked.

Voltmeter should indicate deflection between 0 – 1 V and 8 – 14 V a few times while tire is turned one revolution.

If check result is not satisfactory, proceed to flow table of DTC P0500 in "ENGINE" section.

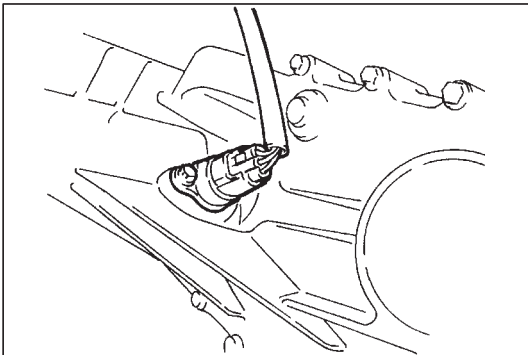

### Removal, Inspection and Installation

Refer to "VSS Removal, Inspection or Installation" in "TRANSFER" section.

## MANIFOLD ABSOLUTE PRESSURE SENSOR

### Inspection

- 1) Disconnect coupler from MAP sensor (1).
- 2) Remove MAP sensor (1).
- 3) Arrange 3 new 1.5 V batteries (2) in series (check that total voltage is 4.5–5.0 V) and connect its positive terminal to “Vin” terminal of sensor and negative terminal to “Ground” terminal. Then check voltage between “Vout” and “Ground”. Also, check if voltage reduces when vacuum is applied up to 400 mmHg by using vacuum pump (3). If check result is not satisfactory, replace MAP sensor (1).

**Output voltage (Vin voltage 4.5 – 5.5 V, ambient temp. 20 – 30°C, 68 – 86°F)**

ALTITUDE (Reference)		BAROMETRIC PRESSURE		OUTPUT VOLTAGE
(ft)	(m)	(mmHg)	(kPa)	(V)
0	0	760	100	3.3 – 4.3
2 000	610	707	94	
2 001	611	Under 707 over 634	94	3.0 – 4.1
5 000	1 524		85	
5 001	1 525	Under 634 over 567	85	2.7 – 3.7
8 000	2 438		76	
8 001	2 439	Under 567 over 526	76	2.5 – 3.3
10 000	3 048		70	

- 4) Install MAP sensor (1) securely.
- 5) Connect MAP sensor (1) coupler securely.

## CRANK SHAFT POSITION SENSOR

### Removal/Installation

Refer to “ENGINE MECHANICAL” section.

### Inspection

Refer to “ENGINE” section.

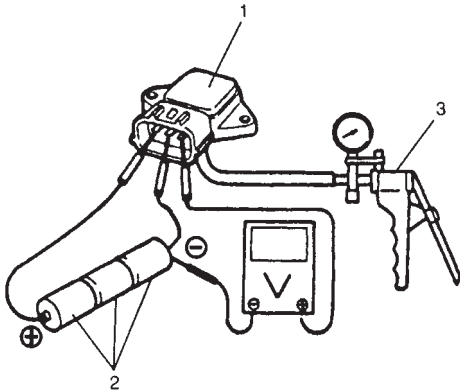

## Left-hand steering vehicle

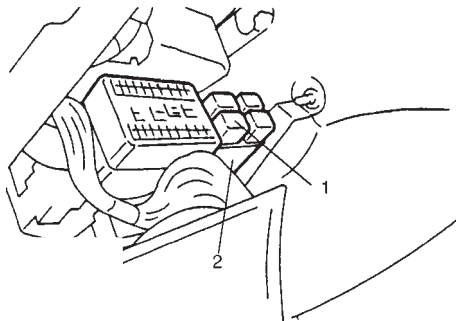

## Right-hand steering vehicle

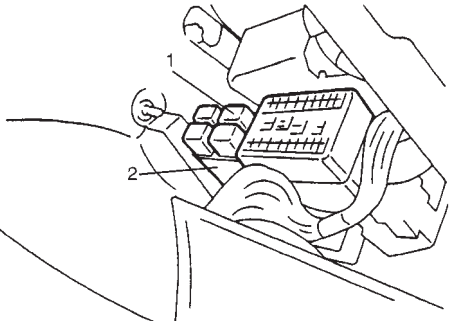
**MAIN RELAY****Inspection**

- 1) Disconnect negative cable at battery.
- 2) Remove main relay (1) from relay box (2).

- 3) Check resistance between each two terminals as in table below.

TERMINALS	RESISTANCE
Between A and B	$\infty$ (Infinity)
Between C and D	70 – 110 $\Omega$ at 20°C, 68°F

If check results are as specified, proceed to next operation check. If not, replace.

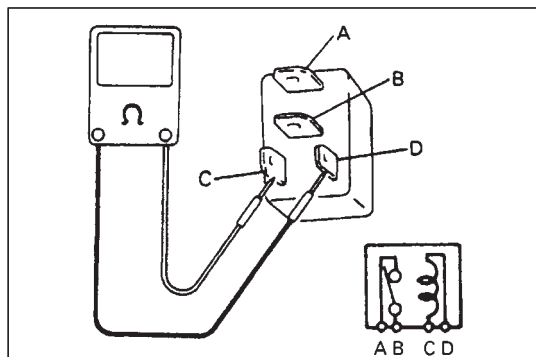

- 4) Check that there is continuity between terminals "A" and "B" when battery is connected to terminals "C" and "D".  
If malfunction is found, replace.

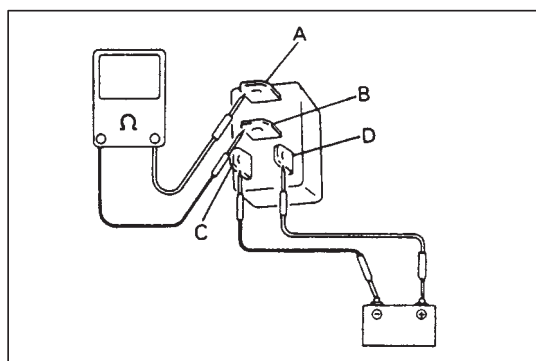

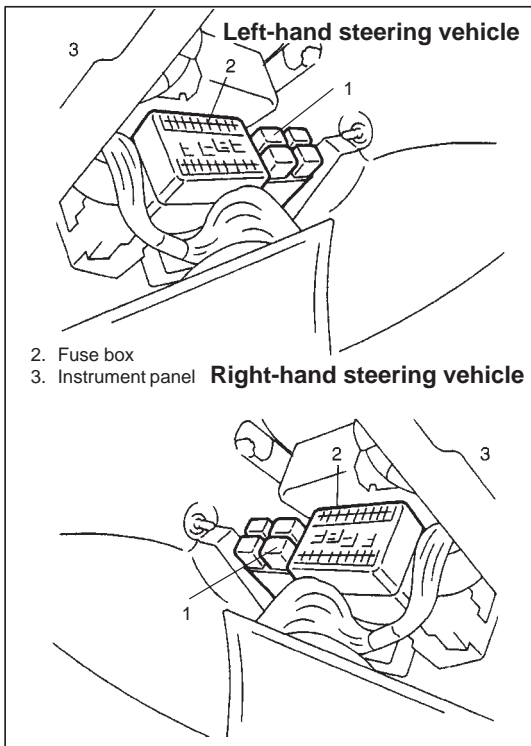

## FUEL PUMP RELAY

### Inspection

- 1) Disconnect negative cable at battery.
- 2) Remove fuel pump relay (1) from relay box.
- 3) Structure of fuel pump relay is the same as that of main relay.  
Check its resistance and operation using the same procedure as that for main relay.  
If malfunction is found, replace.

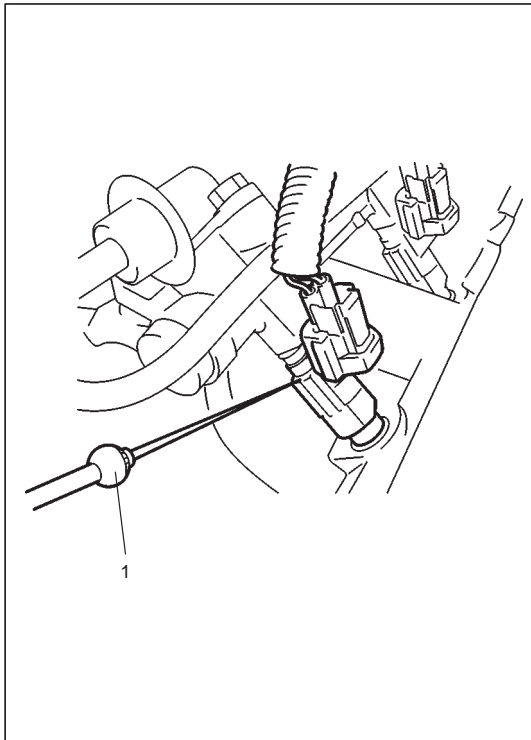

## FUEL CUT OPERATION

### Inspection

#### NOTE:

**Before inspection, check to make sure that gear shift lever is in Neutral position (with A/T model, selector lever in "P" range) and that parking brake lever is pulled all the way up.**

- 1) Warm up engine to normal operating temperature.
- 2) While listening to sound of injector by using sound scope (1) or such, increase engine speed to higher than 3,000 r/min.
- 3) Check to make sure that sound to indicate operation of injector stops when throttle valve is closed instantly and it is heard again when engine speed is reduced to less than about 2,000 r/min.

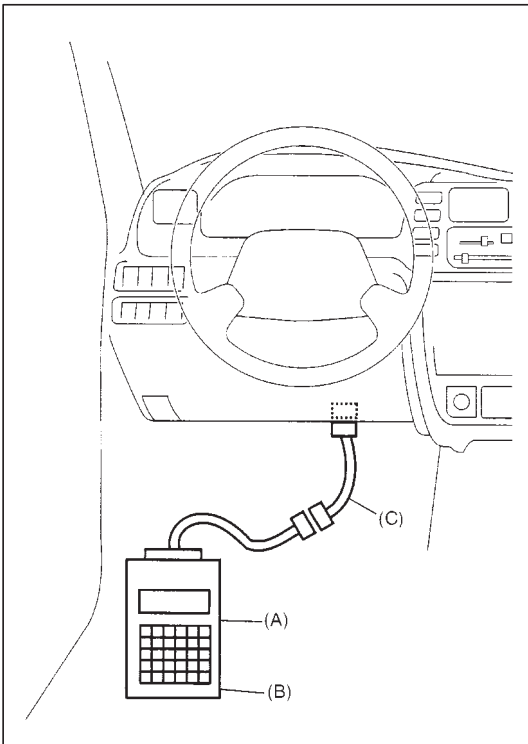

## EMISSION CONTROL SYSTEM

### EGR SYSTEM (IF EQUIPPED)

#### System Inspection [Using SUZUKI scan tool (Tech 1)]

- 1) Connect Tech 1 to data link connector (DLC) with ignition switch OFF.

#### Special tool

- (A): SUZUKI scan tool, Tech 1
- (B): Mass storage cartridge
- (C): 16/14 pin DLC cable

#### NOTE:

For operation procedure of cartridge, refer to its cartridge operator's manual.

- 2) Start engine and warm up it to normal operating temperature.

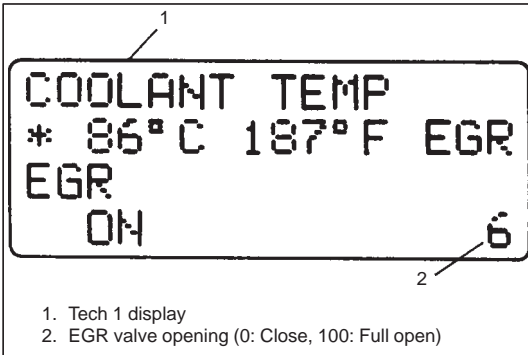

- 3) With engine idling (without depressing accelerator pedal), open EGR valve by using "MISC. TEST" mode.

In this state, according as EGR valve opening increases engine idle speed drops. If not, possible cause is clogged EGR gas passage, stuck or faulty EGR valve.

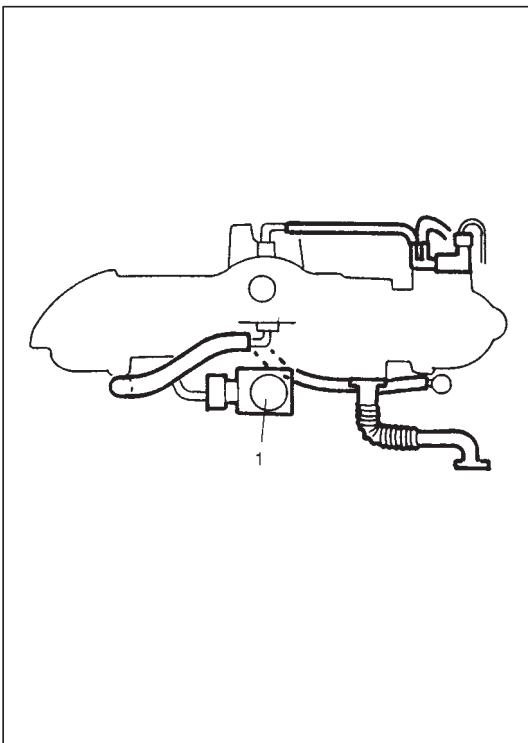

#### Removal

- 1) Disconnect negative cable at battery.
- 2) Disconnect EGR valve coupler.
- 3) Remove EGR valve (1) and gasket from intake collector.

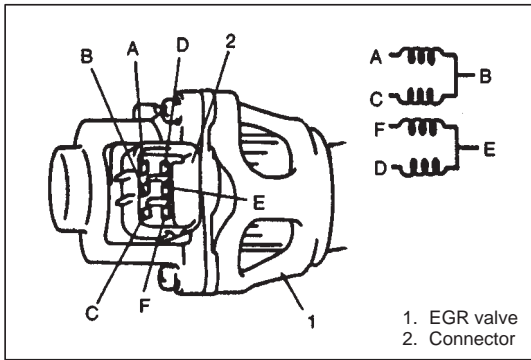

### Inspection

- 1) Check resistance between following terminals of EGR valve in each pair.

Terminals	Standard resistance
A - B C - B F - E D - E	20 - 24 $\Omega$ at 20°C, 68F
B - valve body E - valve body	Infinity ( $\infty$ )

If found faulty, replace EGR valve assembly

- 2) Remove carbon from EGR valve (1) gas passage.

#### NOTE:

**Do not use any sharp-edged tool to remove carbon.  
Be careful not to damage or bend EGR valve, valve seat (3)  
and rod.**

- 3) Inspect valve (2), valve seat and rod for fault, cracks, bend or other damage.

If found faulty, replace EGR valve assembly.

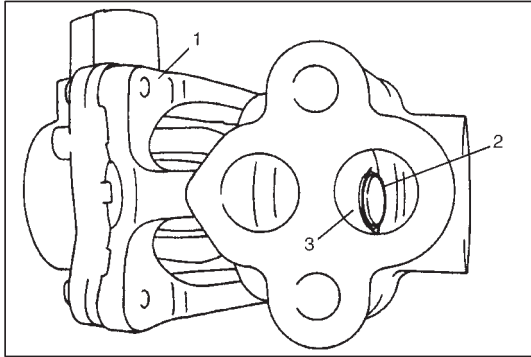

### Installation

Reverse removal procedure noting following.

- Clean mating surface of valve and intake manifold.
- Use new gasket.

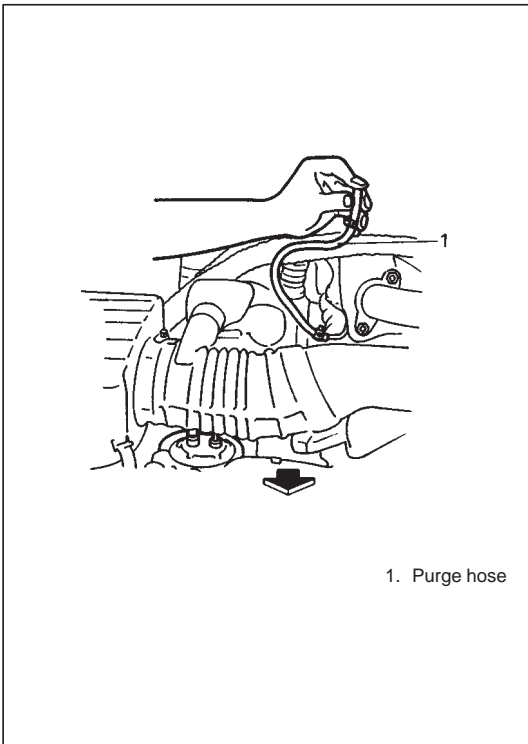

## EVAPORATIVE EMISSION CONTROL SYSTEM

### EVAP Canister Purge Inspection

- 1) Warm up engine to normal operating temperature and keep idling 5 min. or more.
- 2) Disconnect purge hose from EVAP canister when engine is running at idle speed.
- 3) Place finger against the end of disconnected hose and check that vacuum is not felt but vibration is felt there when engine is running at idle speed.
- 4) Also check that vacuum is felt when engine speed is increased to higher than about 2,000 r/min.

If check result is not satisfactory, check vacuum passage, hoses, EVAP canister purge valve, wire harness and ECM (PCM).

### EVAP Canister Purge Valve Inspection

### EVAP Canister Inspection

### Tank Pressure Control Valve Inspection

Refer to Section 6E1.

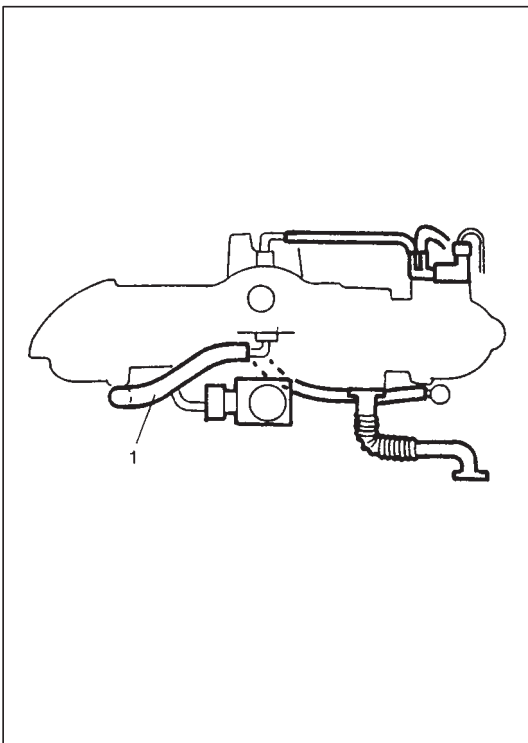

## PCV SYSTEM

### NOTE:

Be sure to check that there is no obstruction in PCV valve or its hoses (1) before checking engine idle speed/IAC duty for obstructed PCV valve or hose hampers its accurate checking.

### PCV HOSE

Check hoses for connection, leakage, clog, and deterioration. Replace as necessary.

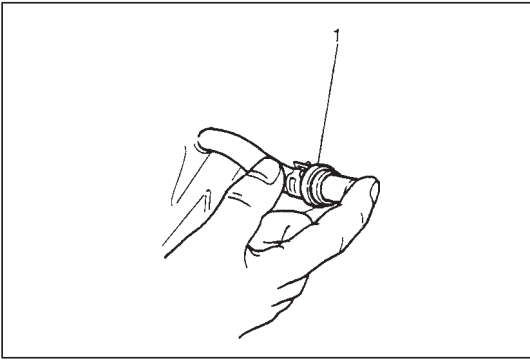

### PCV VALVE

- 1) Disconnect PCV valve (1) from cylinder head cover and plug head cover hole.
- 2) Run engine at idle.
- 3) Place your finger over end of PCV valve to check for vacuum. If there is no vacuum, check for clogged valve. Replace as necessary.

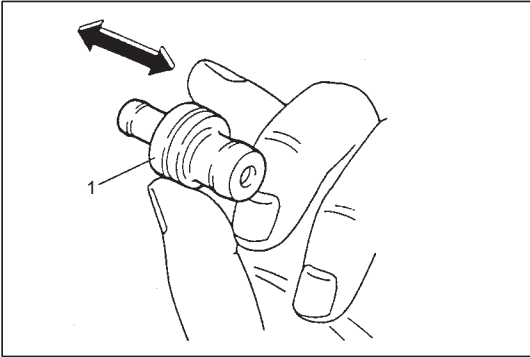

- 4) After checking vacuum, stop engine and remove PCV valve (1). Shake valve and listen for the rattle of check needle inside the valve. If valve does not rattle, replace valve.
- 5) After checking, connect PCV valve, PCV hose and clamp securely.

## TIGHTENING TORQUE SPECIFICATIONS

Fastening parts	Tightening torque		
	N·m	kg·m	lb·ft
Heated oxygen sensor	45	4.5	32.5
Fuel pressure regulator bolts	10	1.0	7.5
Fuel pipe union bolts	30	3.0	22.0
Engine coolant temp. sensor	15	1.5	11.0

## SPECIAL TOOLS

		<ol style="list-style-type: none"> <li>1. Pressure gauge 09912-58441</li> <li>2. Pressure hose 09912-58431</li> <li>3. 3-way joint &amp; hose 09912-58490</li> <li>4. Checking tool set 09912-58421</li> <li>4-1. Tool body &amp; washer</li> <li>4-2. Body plug</li> <li>4-3. Body attachment-1</li> <li>4-4. Holder</li> <li>4-5. Return hose &amp; clamp</li> <li>4-6. Body attachment-2 &amp; washer</li> <li>4-7. Hose attachment-1</li> <li>4-8. Hose attachment-2</li> </ol>
<p>09917-47010 Vacuum pump gauge</p>	<p>09930-88521 Injector test lead</p>	<ol style="list-style-type: none"> <li>1. Storage case</li> <li>2. Operator's manual</li> <li>3. Tech 1A</li> <li>4. DLC cable</li> <li>5. Test lead/probe</li> <li>6. Power source cable</li> <li>7. DLC cable adaptor</li> <li>8. Self-test adaptor</li> </ol> <p>09931-76011 SUZUKI scan tool (Tech 1A)</p>
<p>SUZUKI scan tool mass storage cartridge</p>	<p>09931-76030 16/14 pin DLC cable</p>	

## SECTION 6F2

# IGNITION SYSTEM (FOR J20/H25 ENGINES)

**WARNING:**

For vehicles equipped with Supplemental Restraint (Air Bag) System:

- Service on and around the air bag system components or wiring must be performed only by an authorized SUZUKI dealer. Refer to “Air Bag System Components and Wiring Location View” under “General Description” in air bag system section in order to confirm whether you are performing service on or near the air bag system components or wiring. Please observe all WARNINGS and “Service Precautions” under “On-Vehicle Service” in air bag system section before performing service on or around the air bag system components or wiring. Failure to follow WARNINGS could result in unintentional activation of the system or could render the system inoperative. Either of these two conditions may result in severe injury.
- Technical service work must be started at least 90 seconds after the ignition switch is turned to the “LOCK” position and the negative cable is disconnected from the battery. Otherwise, the system may be activated by reserve energy in the Sensing and Diagnostic Module (SDM).

6F2

## CONTENTS

<b>GENERAL DESCRIPTION</b> .....	6F2- 2
System wiring .....	6F2- 2
Components .....	6F2- 3
<b>DIAGNOSIS</b> .....	6F2- 4
Diagnostic flow table .....	6F2- 4
Ignition spark check .....	6F2- 6
Ignition timing check and adjustment .....	6F2- 6
<b>ON-VEHICLE SERVICE</b> .....	6F2- 9
Ignition coil assembly (igniter and ignition coil) .....	6F2- 9
Spark plug .....	6F2- 9
CMP sensor .....	6F2-11
Noise suppressor .....	6F2-12
<b>TIGHTENING TORQUE SPECIFICATIONS</b> .....	6F2-14
<b>SPECIAL TOOLS</b> .....	6F2-14

## GENERAL DESCRIPTION

The ignition system is a direct ignition system. It consists of the parts as described below and has an electronic ignition control system.

- ECM (or PCM)

It detects the engine condition through the signals from the sensors, determines the most suitable ignition timing and time for electricity to flow to the primary coil and sends a signal to the igniter (in ignition coil assembly).

- Ignition coil assembly (including an igniter and an ignition coil)

The ignition coil assembly has a built-in igniter and ignition coil which turns ON and OFF the primary current of the ignition coil according to the signal from ECM (or PCM). When the ignition coil primary current is turned OFF, a high voltage is induced in the secondary wiring. One ignition coil is in charge of ignition of one cylinder only.

- Spark plug and noise suppressor

- CMP sensor, TP sensor, ECT sensor and MAF sensor

For their details, refer to SECTION 6E1 or 6E2.

This ignition system does not have a distributor and high-tension cords but each cylinder has an ignition coil assembly (igniter and ignition coil) and the secondary voltage which occurred in the ignition coil is sent to the spark plug directly. Also, the signal(s) are sent from the CMP sensor to ECM (or PCM) so as to control each ignition coil independently through the igniter (in ignition coil assembly).

## SYSTEM WIRING

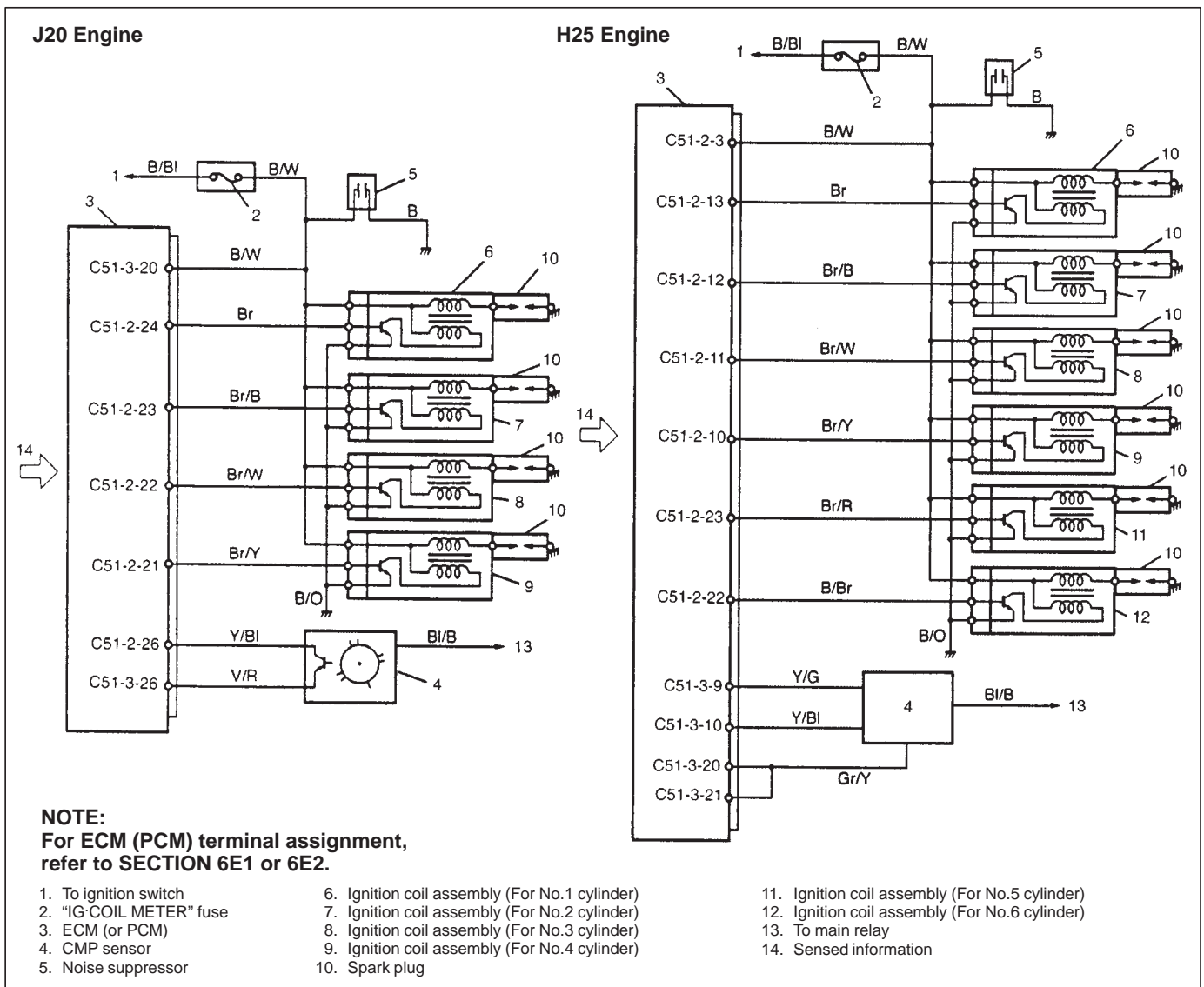

## COMPONENTS

### J20 Engine

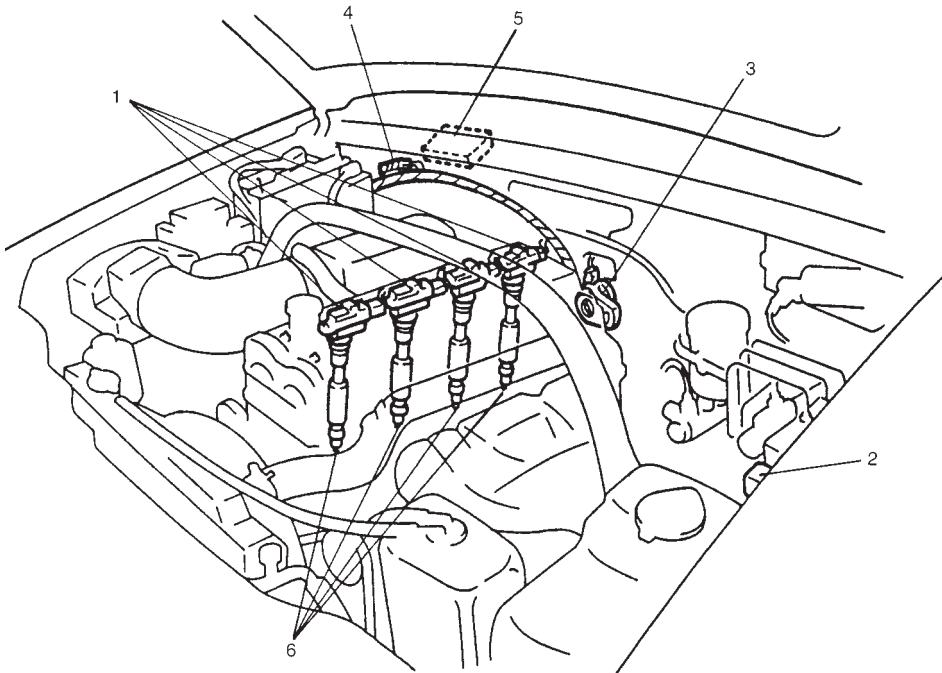

### H25 Engine

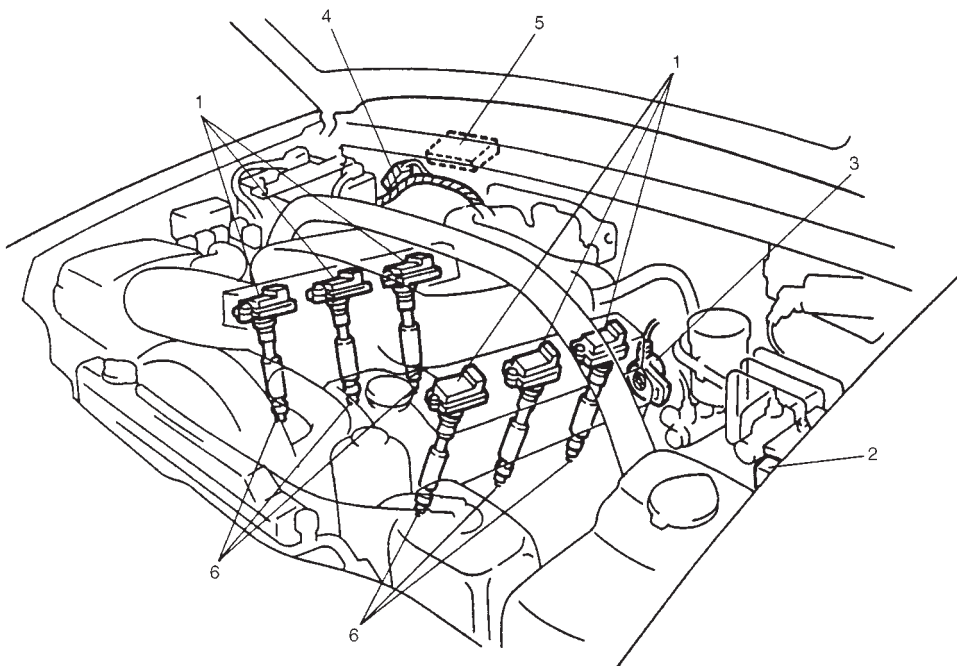

**NOTE:**

Above figure shows left hand steering vehicle.  
For right hand steering vehicle, parts with (\*) are  
installed at the other side.

1. Ignition coil assembly (Igniter and ignition coil)
2. Monitor coupler (\*) (if equipped)
3. CMP sensor
4. Noise suppressor
5. ECM (or PCM) (\*)
6. Spark plug

## DIAGNOSIS

Condition	Possible Cause	Correction
<b>Engine cranks, but will not start or hard to start</b>	<b>No spark</b> <ul style="list-style-type: none"> <li>◦ Blown fuse for ignition coil assembly</li> <li>◦ Loose connection or disconnection of lead wire</li> <li>◦ Faulty spark plug(s)</li> <li>◦ Faulty ignition coil assembly(s)</li> <li>◦ Faulty CMP sensor</li> <li>◦ Faulty ECM (or PCM)</li> <li>◦ Maladjusted ignition timing</li> </ul>	Replace Connect securely  Adjust, clean or replace Replace Replace Replace Adjust
<b>Poor fuel economy or engine performance</b>	<ul style="list-style-type: none"> <li>◦ Incorrect ignition timing</li> <li>◦ Faulty spark plug(s)</li> <li>◦ Faulty ignition coil assembly(s)</li> <li>◦ Faulty CMP sensor</li> <li>◦ Faulty ECM (or PCM)</li> </ul>	Adjust Adjust, clean or replace Replace Replace Replace

## DIAGNOSTIC FLOW TABLE

STEP	ACTION	YES	NO
1	Was "Engine Diagnostic Flow Table" in SECTION 6 or 6-1 performed?	Go to Step 2.	Go to "Engine Diagnostic Flow Table" in SECTION 6 or 6-1.
2	Ignition Spark Test 1) Check all spark plug for condition and type, referring to "Spark Plug" in this section. 2) If OK, perform ignition spark test, referring to "Ignition Spark Check" in this section. Is spark emitted from all spark plugs?	Go to Step 8 on the next page.	Go to Step 3.
3	Diagnostic Trouble Code (DTC) Check 1) Check DTC stored in ECM (or PCM), referring to "Diagnostic Trouble Code (DTC) Check" in SECTION 6E1 or 6E2. Is DTC stored?	Go to applicable flow table corresponding to that code No. in SECTION 6E1 or 6E2.	Go to Step 4.
4	Electrical Connection Check 1) Check ignition coil assemblies for electrical connection. Are they connected securely?	Go to Step 5.	Connect securely.
5	Ignition Coil Assembly Power Supply, Ground and Trigger Signal Circuits Check 1) Check these circuits for open and short. Are circuits in good condition?	Go to Step 6 on the next page.	Repair or replace.

STEP	ACTION	YES	NO
6	Ignition Coil Assembly Check 1) Substitute a known-good ignition coil assembly and then repeat Step 2. Is check result of Step 2 satisfactory?	Malfunction of ignition coil assembly.	Go to Step 7.
7	CMP Sensor Check 1) Check CMP sensor. Refer to Step 6 or 7 of DTC P0340 Diag. Flow Table in SECTION 6 or 6-1. Is check result satisfactory?	Substitute a known-good ECM (or PCM) and then repeat Step 2.	Tighten CMP sensor bolt or replace CMP sensor.
8	Ignition Timing Check 1) Check initial ignition timing and ignition timing advance, referring to "Ignition Timing Check And Adjustment" in this section. Is check result satisfactory?	System is in good condition.	Adjust ignition timing or check ECM (PCM) input signals related to this system.

Oscilloscope waveforms

**J20 Engine**

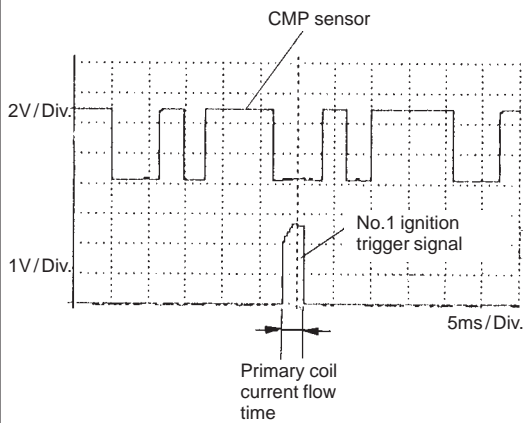

Waveforms at specified idle speed

**H25 Engine**

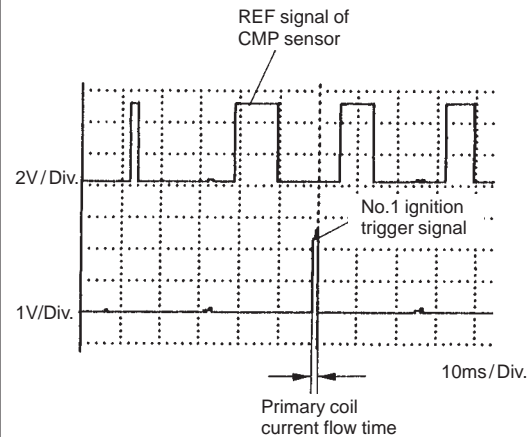

Waveforms at specified idle speed

**Reference**

**J20 engine**

Oscilloscope waveforms of CMP sensor and No.1 ignition trigger signal are as shown in figure when connecting oscilloscope between terminals C51-2-26 and C51-3-26 of ECM (PCM) connectors connected to ECM (PCM), and between terminal C51-2-24 and ground.

**H25 engine**

Oscilloscope waveforms of CMP sensor REF signal and No.1 ignition trigger signal are as shown in figure when connecting oscilloscope between terminal C51-3-10 of ECM (PCM) connector connected to ECM (PCM) and ground, and between terminal C51-2-13 and ground.

## IGNITION SPARK CHECK

- 1) For H25 engine, remove surge tank cover.
- 2) Disconnect injector coupler.

### WARNING:

**Without disconnection of injector coupler, combustible gas may come out from spark plug holes during this test and may get ignited in engine room.**

- 3) Remove spark plug and check it for condition and type, referring to "Spark Plug" under "On-Vehicle Service" later in this section.
- 4) If OK, connect ignition coil coupler to ignition coil assembly and connect spark plug to ignition coil assembly. Ground spark plug.
- 5) Crank engine and check if each spark plug sparks.  
If no spark is emitted, inspect the related parts as described under "Diagnosis" earlier in this section.
- 6) After checking, install spark plug, referring to "Spark Plug" under "On-Vehicle Service" later in this section.
- 7) Connect injector coupler.
- 8) For H25 engine, install surge tank cover.

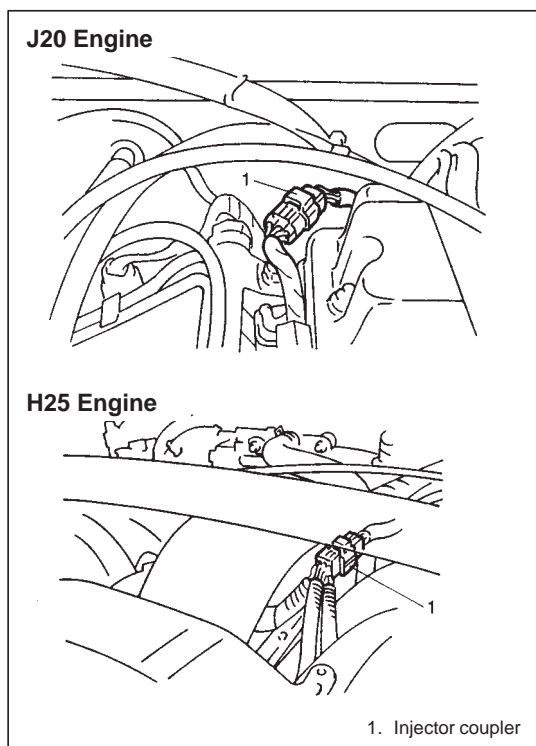

## IGNITION TIMING CHECK AND ADJUSTMENT

### NOTE:

**Before starting engine, place transmission gear shift lever in "Neutral" (shift selector lever to "P" range for A/T model), and set parking brake.**

- 1) Start engine and warm it up to normal operating temperature.
- 2) Make sure that all of electrical loads except ignition are switched off.
- 3) Check to be sure that idle speed is within specification.  
Refer to SECTION 6E1 or 6E2.
- 4) [Using SUZUKI scan tool (Tech 1)]  
Connect SUZUKI scan tool (Tech 1) to DLC (1) with ignition switch OFF, restart engine and fix ignition timing by using fixed spark mode of SUZUKI scan tool (Tech 1).

### Special Tool

**(A): 09931-76011 (SUZUKI scan tool)**

**(B): Mass storage cartridge**

**(C): 16/14 pin DLC (OBD-II adaptor) cable**

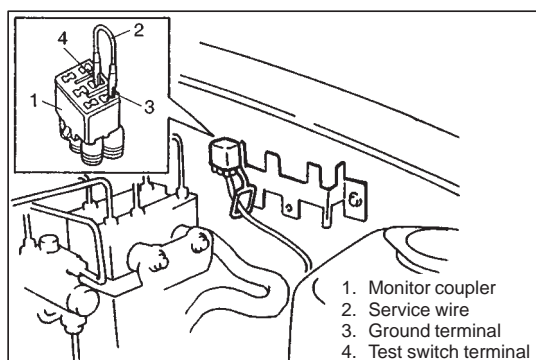
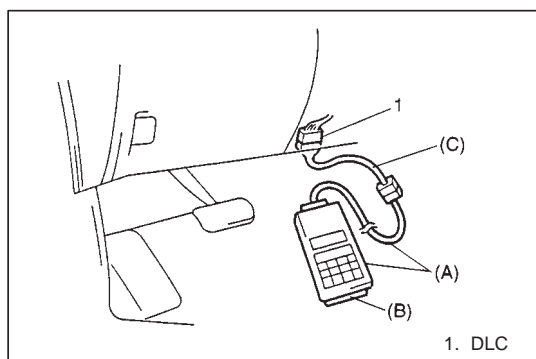

[Not using SUZUKI scan tool (Tech 1)]

- a) Remove monitor coupler cap.
- b) Ground test switch terminal in monitor coupler by using service wire so that ignition timing is fixed on initial one.

- 5) Set timing light to ignition harness for No.1 cylinder.
- 6) Using timing light, check that timing observed from viewpoint is within specification.

**Initial ignition timing of viewpoint**

**(when it is fixed by Tech 1 or service wire):  $5 \pm 1^\circ$  BTDC**

**Ignition order: 1-3-4-2 (J20 engine)**

**: 1-6-5-4-3-2 (H25 engine)**

**Special Tool**

**(A): 09930-76420**

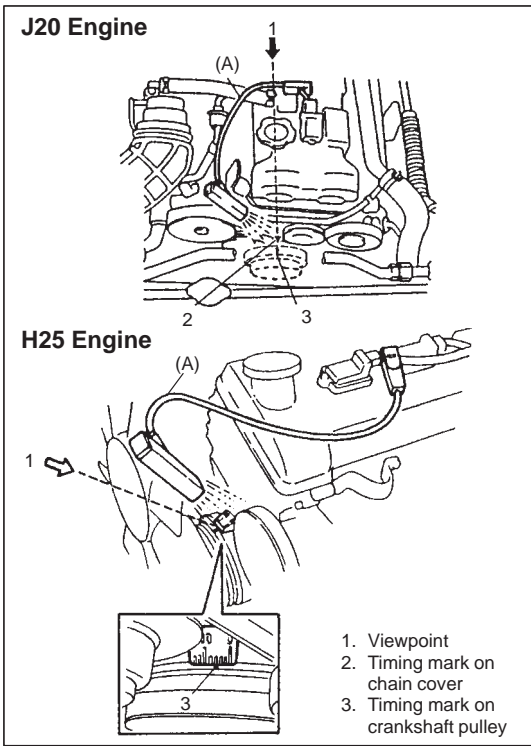

- 7) If ignition timing is out of specification, loosen flange bolt(s), adjust timing by turning CMP sensor while engine is running, and then tighten bolt(s).

**Tightening Torque**

**(a): 15 N·m (1.5 kg·m, 11.0 lb·ft)**

- 8) After tightening bolt(s), recheck that ignition timing is within specification.

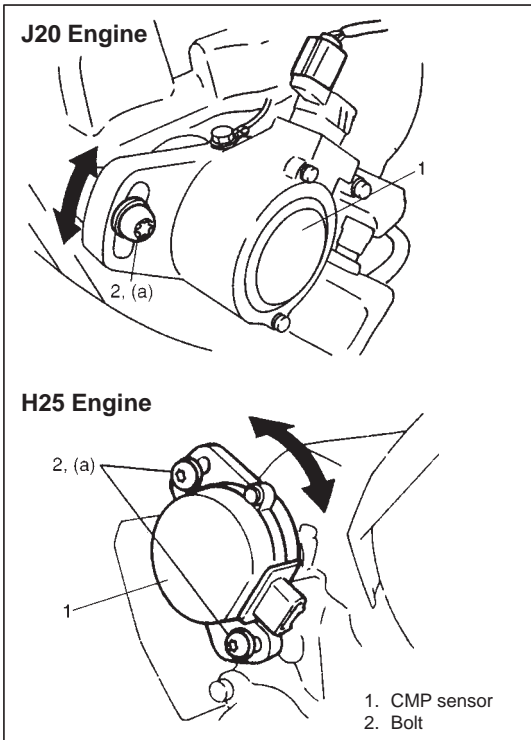

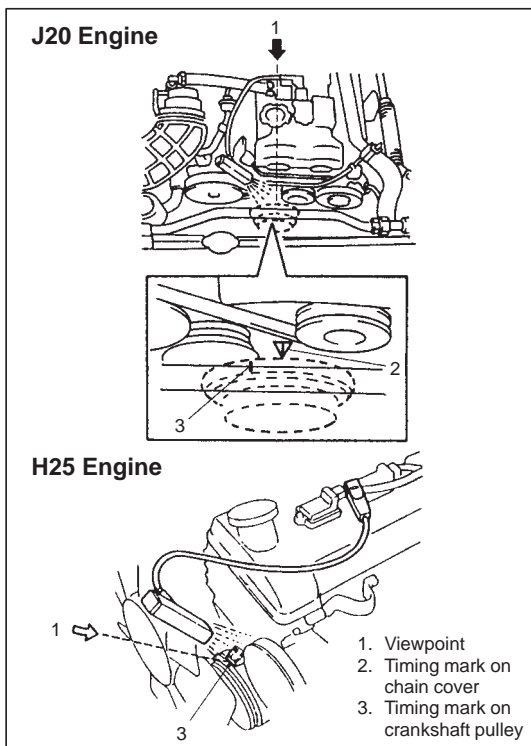

- 9) After checking and/or adjusting, end fixed spark mode of SUZUKI scan tool or disconnect service wire from monitor coupler.

**CAUTION:**

Driving with test switch terminal grounded will cause damage to catalyst.

Be sure to disconnect service wire after adjustment.

**NOTE:**

In this state, ignition timing may vary more or less of initial ignition timing but it is nothing abnormal.

- 10) With engine idling (closed throttle position and vehicle stopped), check that ignition timing is about BTDC  $12^{\circ} - 16^{\circ}$  (J20 engine),  $10^{\circ} - 13^{\circ}$  (H25 engine with monitor connector),  $6^{\circ} - 12^{\circ}$  (H25 engine without monitor connector) (shown in the figure). Also, check that increasing engine speed advances ignition timing.

If above check results are not satisfactory, check input signals related to this system.

## ON-VEHICLE SERVICE

### IGNITION COIL ASSEMBLY (IGNITER AND IGNITION COIL)

#### REMOVAL

- 1) For H25 engine, remove ignition coil cover.
- 2) Disconnect ignition coil coupler.
- 3) Remove ignition coil bolt, and then pull out ignition coil assembly.

#### INSPECTION

Check ignition coil assembly for the following:

- ° Damage
- ° Deterioration
- ° Terminal for corrosion

#### INSTALLATION

Install in reverse order of removal.

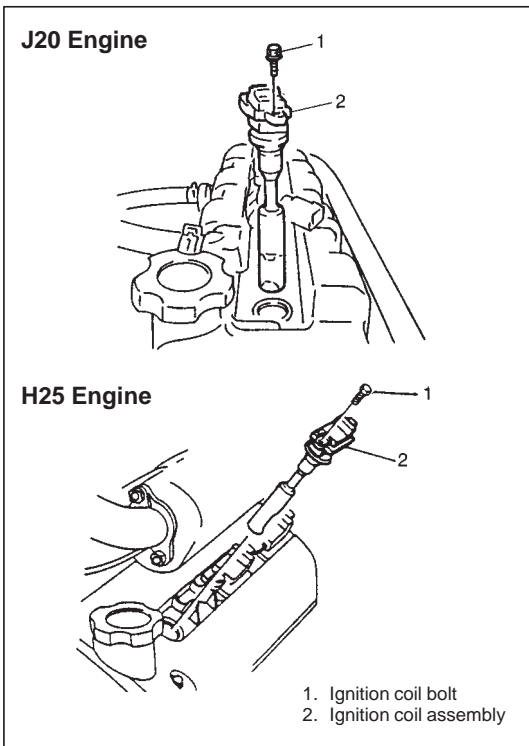

### SPARK PLUG

#### REMOVAL

- 1) For H25 engine, remove ignition coil cover.
- 2) Disconnect ignition coil coupler.
- 3) Remove ignition coil bolt, and then pull out ignition coil assembly.
- 4) Remove spark plug.

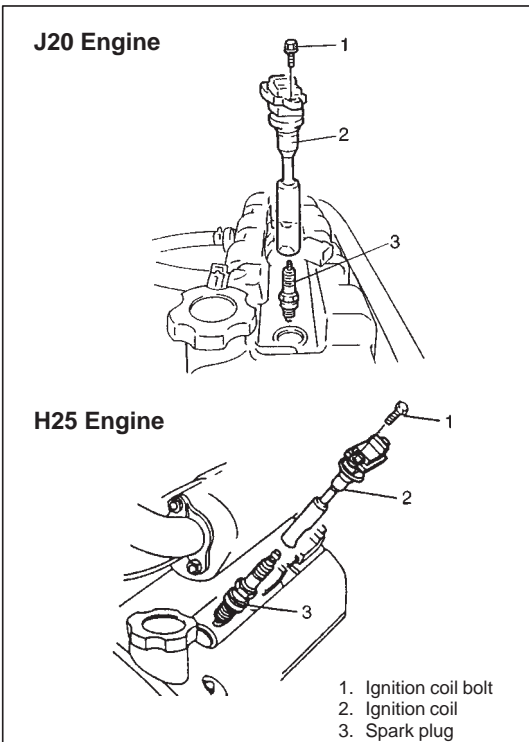

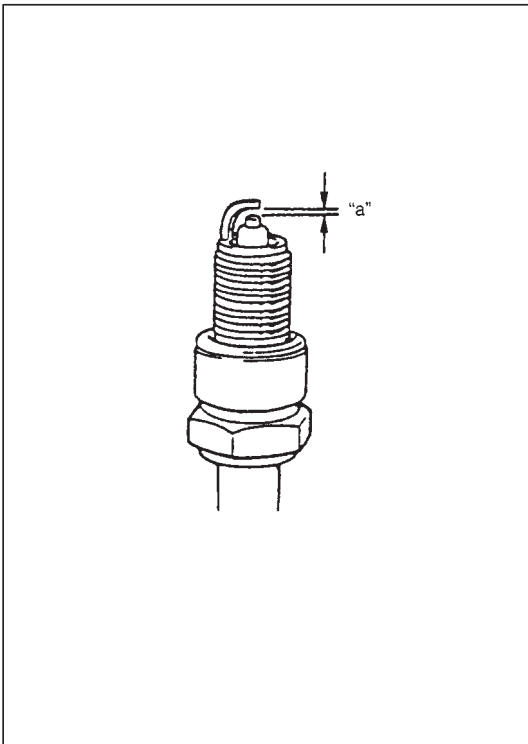

## INSPECTION

### CAUTION:

When servicing the iridium/platinum sparkplugs (slender center electrode type plugs), do not touch the center electrode to avoid damage to it. The electrode is not strong enough against mechanical force as it is slender and its material is not mechanically tough.

Inspect them for electrode wear, carbon deposits and insulator damage.

If any abnormality is found, adjust air gap, clean with spark plug cleaner or replace them with specified new plug.

**Spark plug air gap "a": 1.0 – 1.1 mm (0.039 – 0.043 in.)**

**Spark plug type:**

**DENSO K20PR-U11/SK16PR11**

**NGK BKR6E-11/\*IFR5J11**

### NOTE:

Under  $-25^{\circ}\text{C}$  ( $-13^{\circ}\text{F}$ ), the spark plugs with an asterisk (\*) are highly recommend for better engine starting performance.

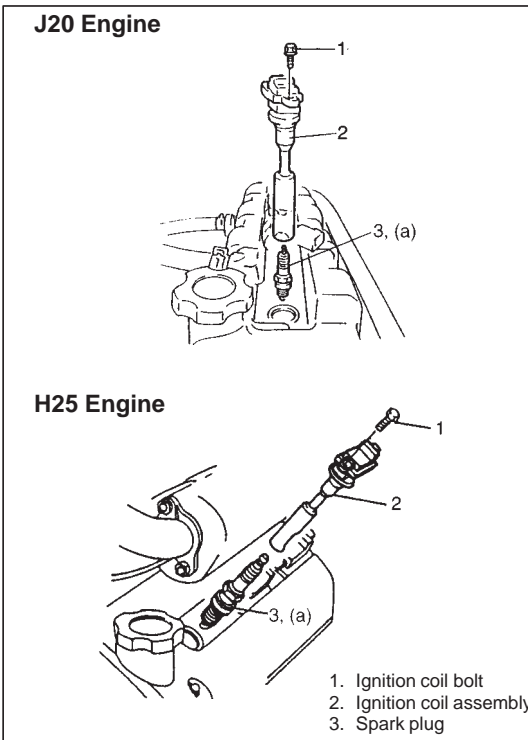

## INSTALLATION

1) Install spark plug(s) and tighten them to specified torque.

### Tightening Torque

**(a): 25 N·m (2.5 kg-m, 18.0 lb-ft)**

2) Install ignition coil assembly securely.

3) Tighten ignition coil bolt, and then connect ignition coil coupler.

4) For H25 engine, install ignition coil cover.

## CMP SENSOR

### CAUTION:

Disassembly is prohibited. If anything faulty is found, replace as an assembly unit.

### REMOVAL

- 1) Disconnect CMP sensor coupler.
- 2) Remove CMP sensor by removing bolt(s).

### INSTALLATION

#### NOTE:

After installing CMP sensor, adjust ignition timing. (Refer to "Ignition Timing Check And Adjustment" in this section.)

- 1) Install a new O-ring with engine oil applied to CMP sensor.

- 2) Install CMP sensor to camshaft.

Fit the dog of CMP sensor coupling into the slots of camshaft, when installing. The dogs of CMP sensor coupling are offset. Therefore, if the dogs can not be fitted into the slots, turn the CMP sensor shaft by 180 degree and try again.

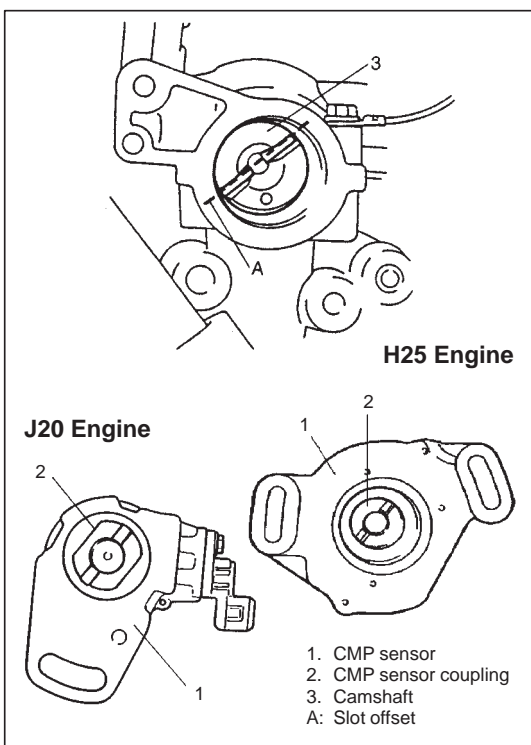
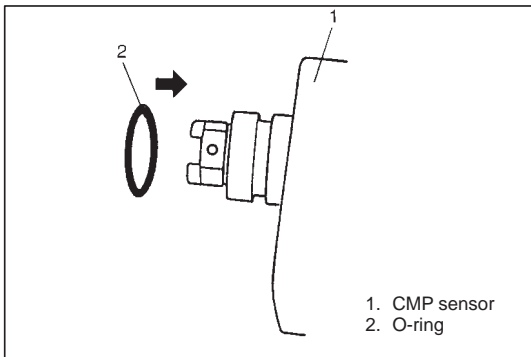
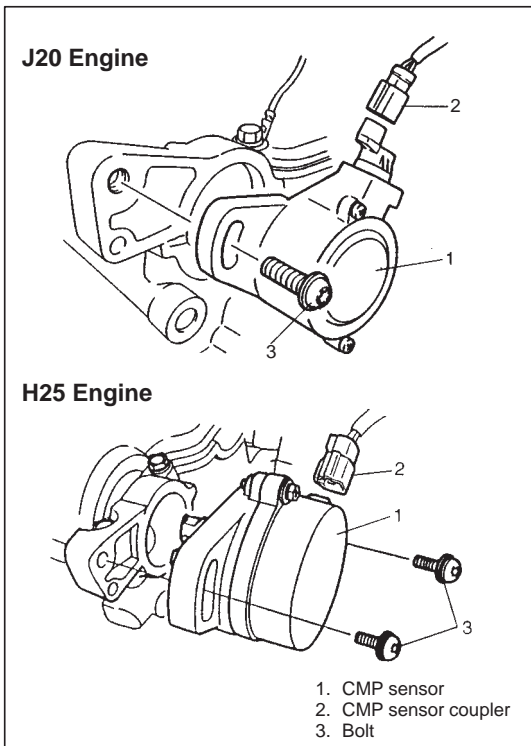

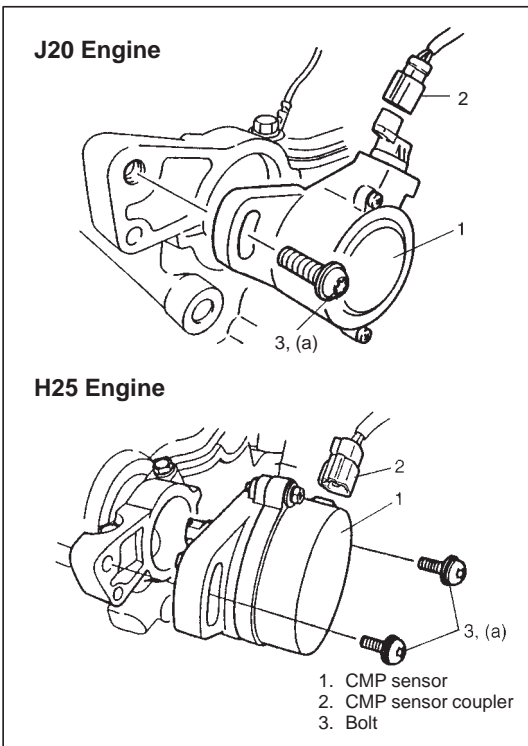

3) Tighten CMP sensor bolts.

**Tightening Torque**

(a): 15 N·m (1.5 kg·m, 11.0 lb-ft)

4) Connect CMP sensor coupler.

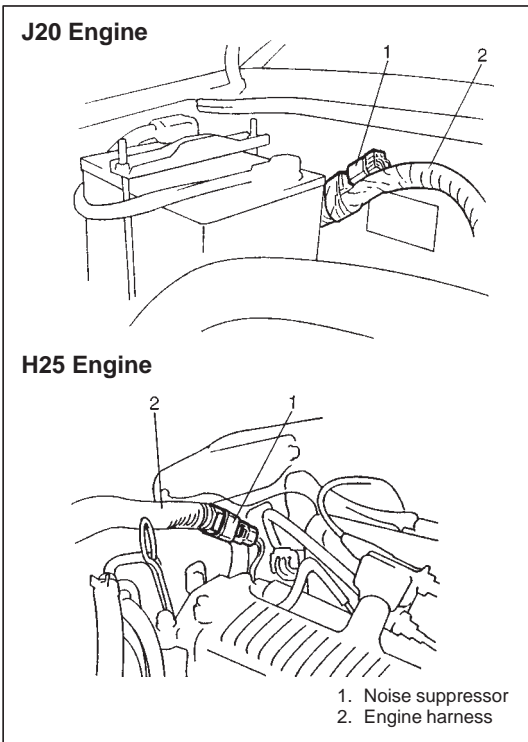

**NOISE SUPPRESSOR**

**REMOVAL**

- 1) Disconnect coupler of noise suppressor.
- 2) Remove noise suppressor.

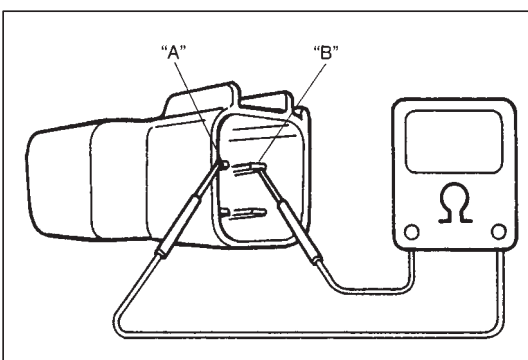

**INSPECTION**

Using ohmmeter, check to be sure that capacitor (condenser) in noise suppressor is not conductive.

If check result is not satisfactory, replace noise suppressor.

## **INSTALLATION**

For installation, reverse removal procedure.

## TIGHTENING TORQUE SPECIFICATIONS

Fastening portion	Tightening torque		
	N·m	kg-m	lb-ft
Spark plug	25	2.5	18.0
CMP sensor bolt	15	1.5	11.0

## SPECIAL TOOLS

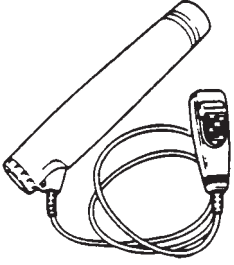
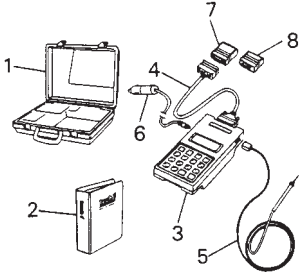
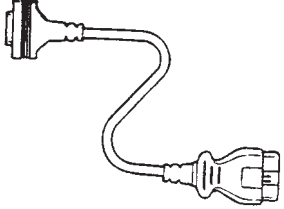
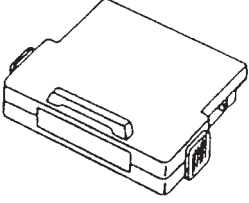
 <p>09930-76420 Timing light (Dry cell type)</p>	 <ol style="list-style-type: none"> <li>1. Storage case</li> <li>2. Operator's manual</li> <li>3. Tech 1A</li> <li>4. DLC cable</li> <li>5. Test lead/probe</li> <li>6. Power source cable</li> <li>7. DLC cable adapter</li> <li>8. Self-test adapter</li> </ol> <p>09931-76011 SUZUKI scan tool (Tech 1A) kit</p>	 <p>09931-76030 16/14 pin DLC cable</p>
 <p>Mass storage cartridge</p>		

**SECTION 6G**

**CRANKING SYSTEM  
(0.9 kW, 1.2 kW and 1.4 kW Reduction Type)**

**NOTE:**

Starting motor vary depending on specifications, etc.

Therefore, be sure to check model and specification of the vehicle being serviced before replacing parts.

**CONTENTS**

<b>GENERAL DESCRIPTION</b> .....	6G- 2
Cranking Circuit .....	6G- 2
Starting Motor Circuit .....	6G- 2
Starting Motor .....	6G- 3
<b>DIAGNOSIS</b> .....	6G- 4
<b>UNIT REPAIR OVERHAUL</b> .....	6G- 6
Dismounting and Remounting .....	6G- 6
Disassembly .....	6G- 6
Reassembly .....	6G-10
Inspection .....	6G-12
Performance Test .....	6G-16
Pull-in test .....	6G-16
Hold-in test .....	6G-16
Plunger and pinion return test .....	6G-16
No-load performance test .....	6G-16
<b>SPECIFICATIONS</b> .....	6G-17
<b>REQUIRED SERVICE MATERIAL</b> .....	6G-18
<b>SPECIAL TOOL</b> .....	6G-18

## GENERAL DESCRIPTION

### CRANKING CIRCUIT

The cranking circuit consists of the battery, starting motor, ignition switch, and related electrical wiring. These components are connected electrically.

Only the starting motor will be covered in this section.

### STARTING MOTOR CIRCUIT

- The magnetic switch coils are magnetized when the ignition switch is closed.
- The resulting plunger and pinion drive lever movement causes the pinion to engage the engine flywheel gear and the magnetic switch main contacts to close, and cranking takes place.
- When the engine starts, the pinion over-running clutch protects the armature from excessive speed until the switch is opened, at which time the return spring causes the pinion to disengage.

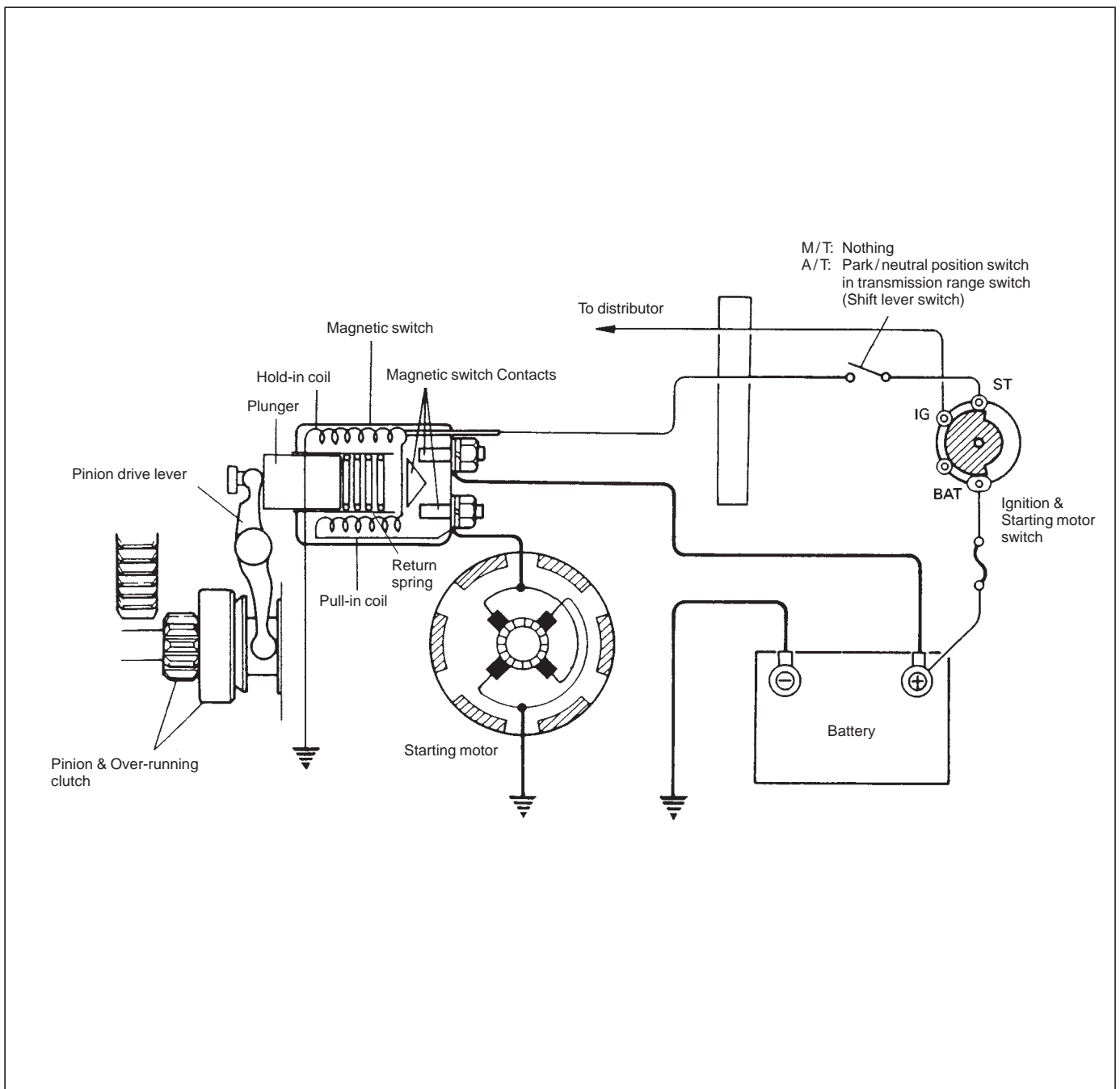

## STARTING MOTOR

The starting motor consists of parts shown in below and has permanent magnets mounted in starting motor yoke (frame).

The magnetic switch assembly and parts in the starting motor are enclosed in the housings so that they will be protected against possible dirt and water splash.

### NOTE:

- Make sure to apply grease before assembly where so indicated "A" in the figure below.
- Spare parts have been lubricated.

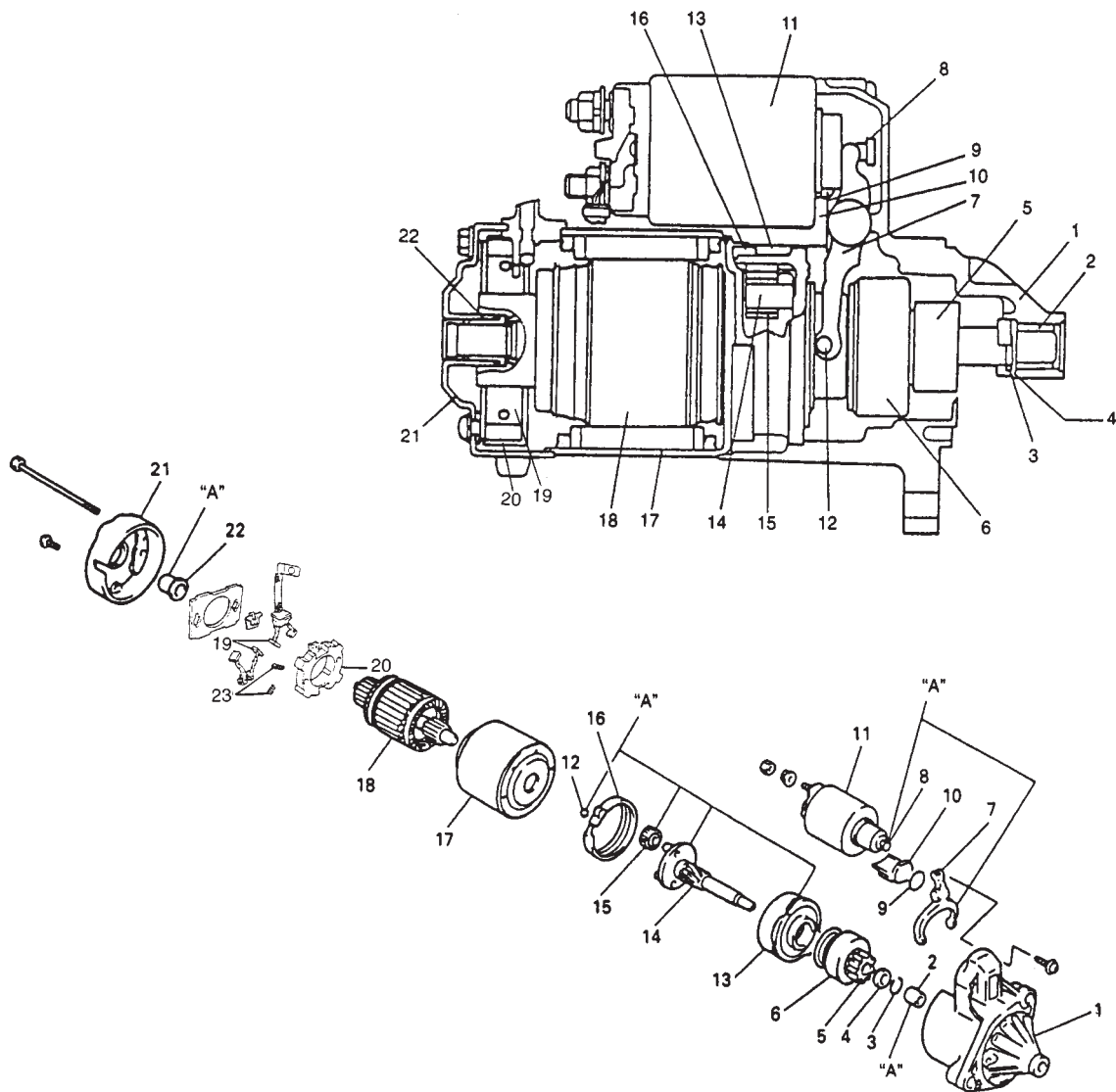

"A": Apply grease (99000-25010)

- |                        |                             |                  |
|------------------------|-----------------------------|------------------|
| 1. Front housing       | 9. Plate                    | 17. Yoke         |
| 2. Bush                | 10. Seal rubber             | 18. Armature     |
| 3. Snap ring           | 11. Magnetic switch         | 19. Brush        |
| 4. Pinion stop ring    | 12. Ball                    | 20. Brush holder |
| 5. Pinion gear         | 13. Internal gear           | 21. Rear bracket |
| 6. Over-running clutch | 14. Planetary carrier shaft | 22. Rear bush    |
| 7. Lever               | 15. Planetary gear          | 23. Brush spring |
| 8. Plunger             | 16. Packing                 |                  |

## DIAGNOSIS

Possible symptoms due to starting system trouble would be as follows:

- Starting motor does not run (or runs slowly)
- Starting motor runs but fails to crank engine
- Abnormal noise is heard

Proper diagnosis must be made to determine exactly where the cause of each trouble lies.....in battery, wiring harness, (including starting motor switch), starting motor or engine.

Do not remove motor just because starting motor does not run. Check following items and narrow down scope of possible causes.

- 1) Condition of trouble
- 2) Tightness of battery terminals (including ground cable connection on engine side) and starting motor terminals
- 3) Discharge of battery
- 4) Mounting of starting motor

Condition	Possible Cause	Correction
<b>Motor not running</b>	<b>No operating sound of magnetic switch</b> <ul style="list-style-type: none"> <li>◦ Shift lever switch is not in P or N, or not adjusted (A/T)</li> <li>◦ Battery run down</li> <li>◦ Battery voltage too low due to battery deterioration</li> <li>◦ Poor contact in battery terminal connection</li> <li>◦ Loose grounding cable connection</li> <li>◦ Fuse set loose or blown off</li> <li>◦ Poor contacting action of ignition switch and magnetic switch</li> <li>◦ Lead wire coupler loose in place</li> <li>◦ Open-circuit between ignition switch and magnetic switch</li> <li>◦ Open-circuit in pull-in coil</li> <li>◦ Brushes are seating poorly or worn down</li> <li>◦ Poor sliding or plunger and/or pinion</li> </ul>	Shift in P or N, or adjust switch. Recharge battery. Replace battery. Retighten or replace. Retighten. Tighten or replace. Replace. Retighten. Repair. Replace magnetic switch. Repair or replace. Repair.
	<b>Operating sound of magnetic switch heard</b> <ul style="list-style-type: none"> <li>◦ Battery run down</li> <li>◦ Battery voltage too low due to battery deterioration</li> <li>◦ Loose battery cable connections</li> <li>◦ Burnt main contact point, or poor contacting action of magnetic switch</li> <li>◦ Brushes are seating poorly or worn down</li> <li>◦ Weakened brush spring</li> </ul>	Recharge battery. Replace battery. Retighten. Replace magnetic switch. Repair or replace. Replace.

Condition	Possible Cause	Correction
<b>Motor not running</b>	<ul style="list-style-type: none"> <li>◦ Burnt commutator</li> <li>◦ Layer short-circuit of armature</li> <li>◦ Crankshaft rotation obstructed</li> </ul>	Replace armature. Replace. Repair.
<b>Starting motor running but too slow (small torque)</b>	<p><b>If battery and wiring are satisfactory, inspect starting motor</b></p> <ul style="list-style-type: none"> <li>◦ Insufficient contact of magnetic switch main contacts</li> <li>◦ Layer short-circuit of armature</li> <li>◦ Disconnected, burnt or worn commutator</li> <li>◦ Worn brushes</li> <li>◦ Weakened brush springs</li> <li>◦ Burnt or abnormally worn end bush</li> </ul>	Replace magnetic switch. Replace. Repair commutator or replace armature. Replace brush. Replace spring. Replace bush.
<b>Starting motor running, but not cranking engine</b>	<ul style="list-style-type: none"> <li>◦ Worn pinion tip</li> <li>◦ Poor sliding of over-running clutch</li> <li>◦ Over-running clutch slipping</li> <li>◦ Worn teeth of ring gear</li> </ul>	Replace over-running clutch. Repair. Replace over-running clutch. Replace flywheel (M/T) or drive plate (A/T).
<b>Noise</b>	<ul style="list-style-type: none"> <li>◦ Abnormally worn bush</li> <li>◦ Worn pinion or worn teeth of ring gear</li> <li>◦ Poor sliding of pinion (failure in return movement)</li> <li>◦ Worn internal or planetary gear teeth</li> <li>◦ Lack of oil in each part</li> </ul>	Replace bush. Replace over-running clutch, flywheel (M/T) or drive plate (A/T). Repair or replace. Replace. Lubricate.
<b>Starting motor does not stop running</b>	<ul style="list-style-type: none"> <li>◦ Fused contact points of magnetic switch</li> <li>◦ Short-circuit between turns of magnetic switch coil (layer short-circuit)</li> <li>◦ Failure of returning action in ignition switch</li> </ul>	Replace magnetic switch. Replace magnetic switch. Replace.

## UNIT REPAIR OVERHAUL

### DISMOUNTING AND REMOUNTING

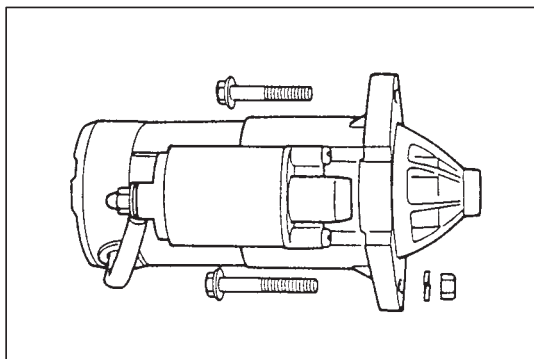

Use following procedure to remove starter:

- 1) Disconnect negative battery lead at battery.
- 2) Disconnect magnetic switch lead wire and battery cable from starting motor terminals.
- 3) Remove two starting motor mount bolts.
- 4) Remove starting motor.
- 5) To install, reverse the above procedure.

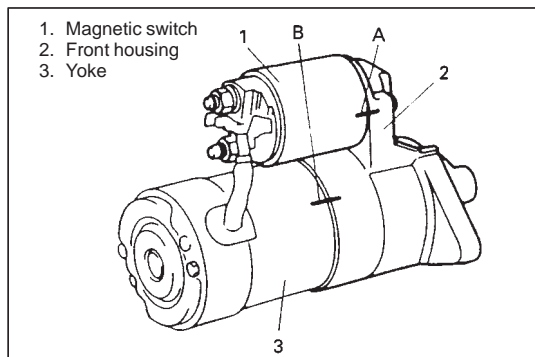

## DISASSEMBLY

### NOTE:

- Before disassembling starting motor, be sure to put match marks at two locations (A & B) as shown in figure left so that any possible mistake can be avoided.
- Do not clamp yoke in a vise or strike it with a hammer during repair operations.

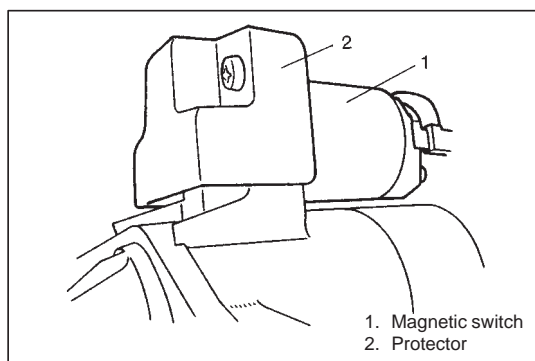

- 1) Remove protector (if equipped) and magnetic switch.

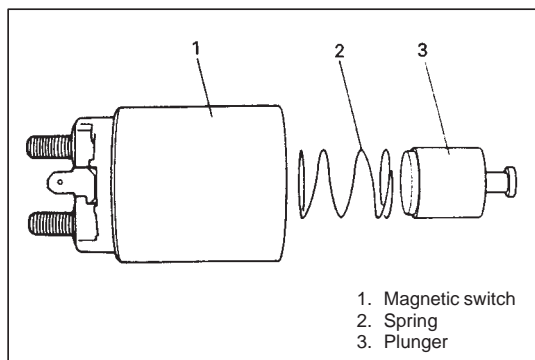

### NOTE:

Don't disassemble this switch. If defective, replace as a complete assembly.

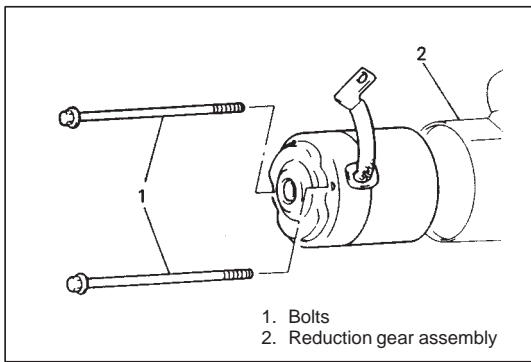

2) Remove bolts shown in left figure, then separate reduction gear assembly from starting motor assembly.

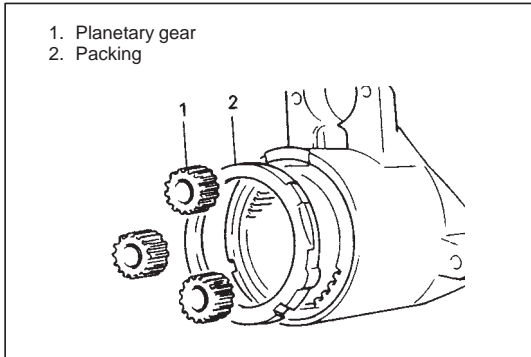

3) To overhaul reduction gear assembly, remove packing and planetary gears.

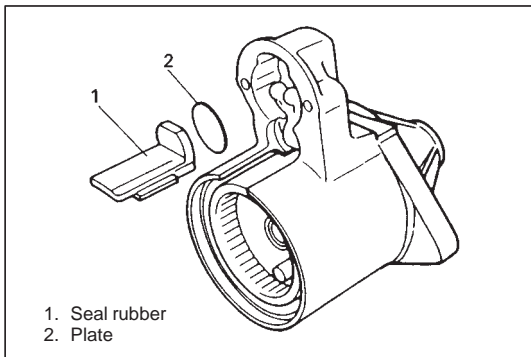

4) Remove seal rubber and plate.

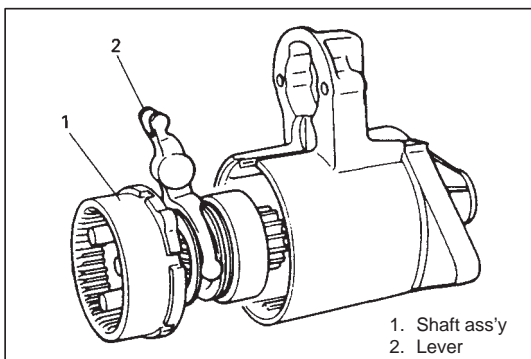

5) Remove shaft assembly with lever.

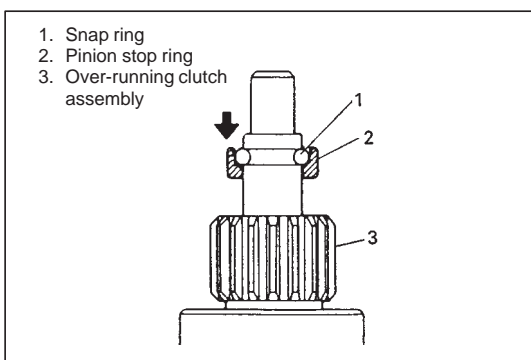

6) Loosen pinion stop ring fixed by snap ring.

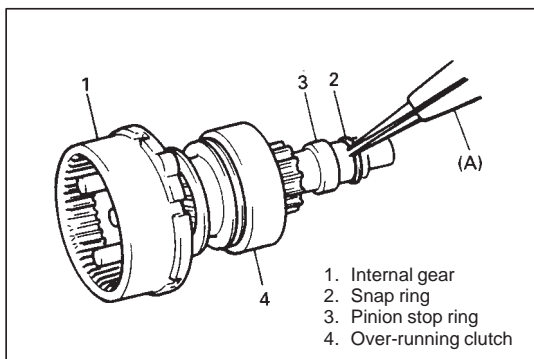

7) Remove snap ring, then pull out pinion stop ring and over-running clutch and internal gear.

**Special Tool**  
**(A): 09900-06107**

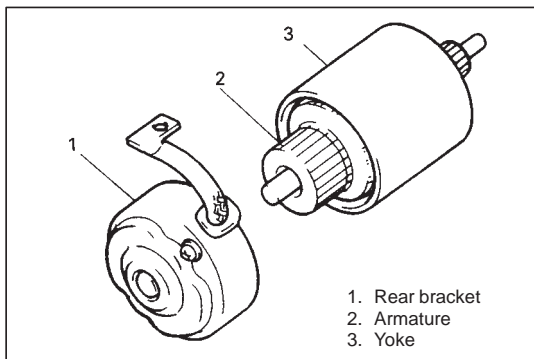

8) Remove rear bracket and brush holder.

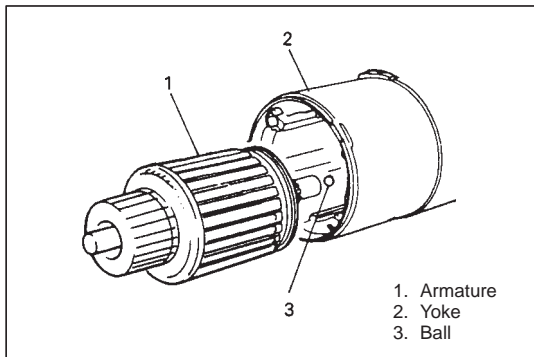

9) Remove armature from yoke and then ball from the end of armature shaft.

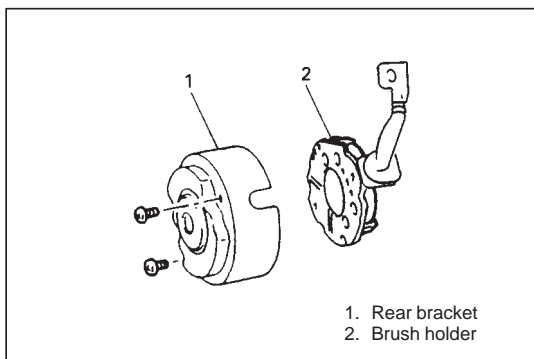

10) Remove brush holder from rear bracket.

11) Remove brush springs and brushes.

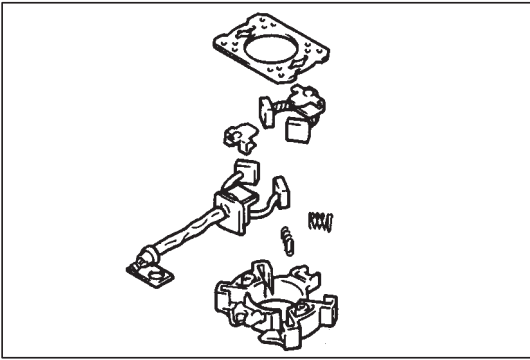

12) Remove rear bracket cap, and then remove rear bush, as required.

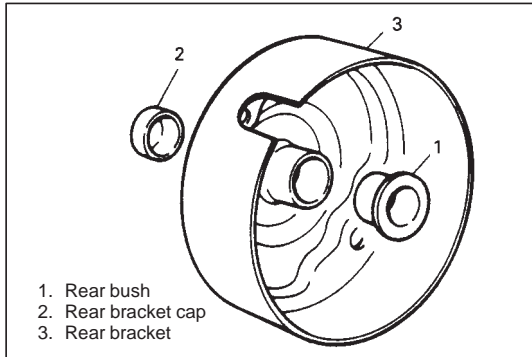

## REASSEMBLY

### CAUTION:

- Washing, adjusting and disassembling of shock absorber (clutch plate) are not allowed.
- New oilless bearing have been lubricated when they are supplied as spare parts. DO NOT wash with grease dissolving solvent nor lubricate them with other lubricant.

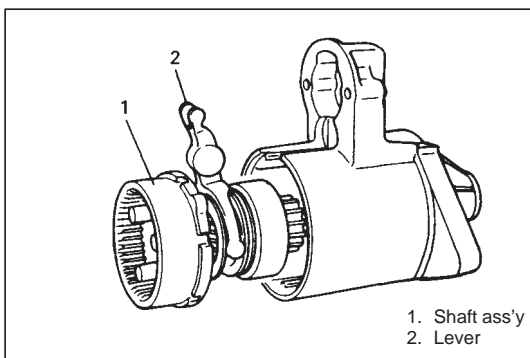
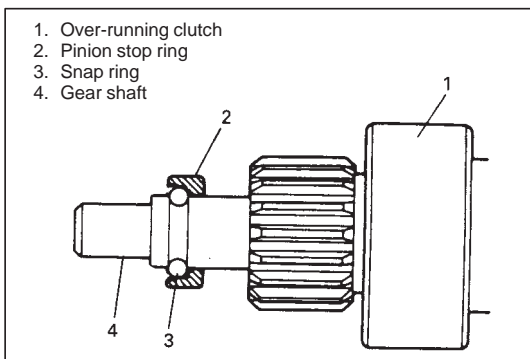
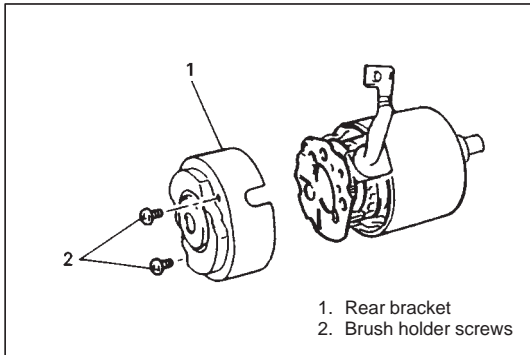
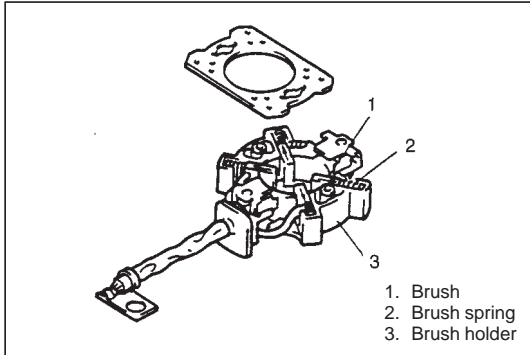

- 1) Inspect component parts (Refer to page 6G-12) and replace with new ones as necessary.
- 2) Apply grease (Refer to page 6G-3).
- 3) Install armature to yoke.
- 4) Install brushes and brush springs to brush holder.
- 5) Install brush holder to armature while pushing 4 brushes outward.
- 6) Install rear bush and then rear bracket cap.
- 7) Install rear bracket.
- 8) Tighten brush holder screws.
- 9) Install over-running clutch assembly to gear shaft, using care for installing direction of pinion stop ring.
- 10) Insert shaft ass'y into front housing with lever positioned as shown left figure.

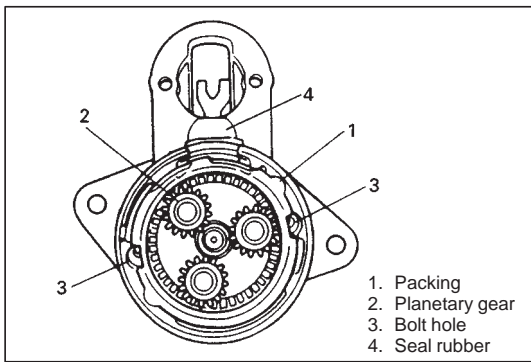

- 11) Install packing so that cuts in packing align with holes for through bolts in front housing.
- 12) Install plate and seal rubber to front housing.

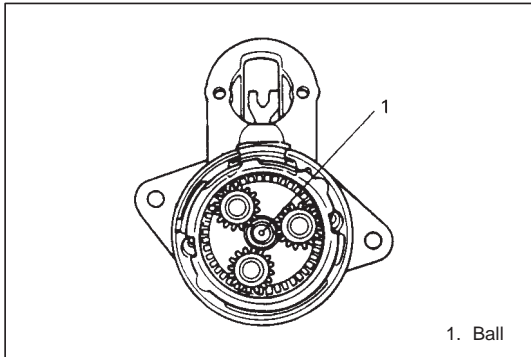

- 13) Apply grease to ball and install ball into shaft hole.

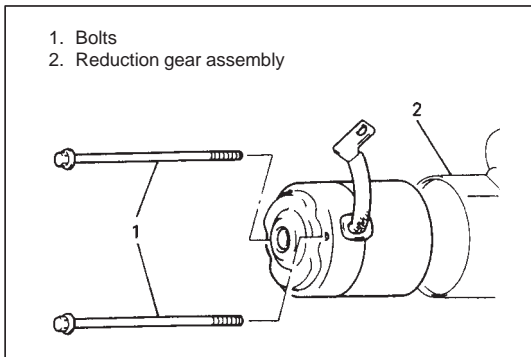

- 14) Install yoke, armature, brush holder and rear bracket to front housing by aligning match marks provided before removal.
- 15) Tighten through bolts.

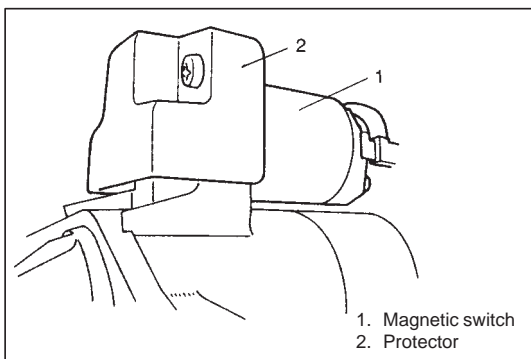

- 16) Install magnetic switch assembly and protector (if equipped). Connect wire (switch to motor) to switch terminal.
- 17) Upon completion of assembly, carry out PERFORMANCE TEST. (Refer to page 6G-16.)

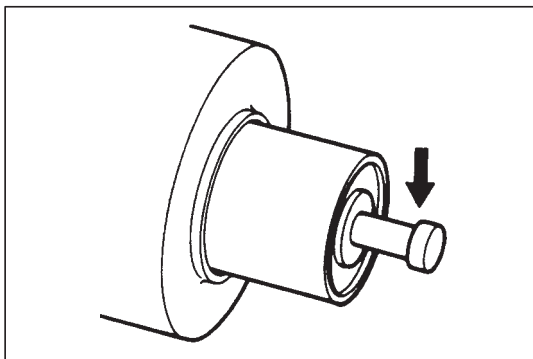

## INSPECTION

### 1. PLUNGER

Inspect plunger for wear. Replace if necessary.

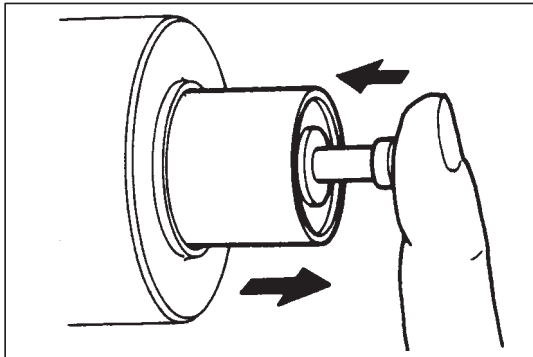

### 2. MAGNETIC SWITCH

Push in plunger and release it. The plunger should return quickly to its original position. Replace if necessary.

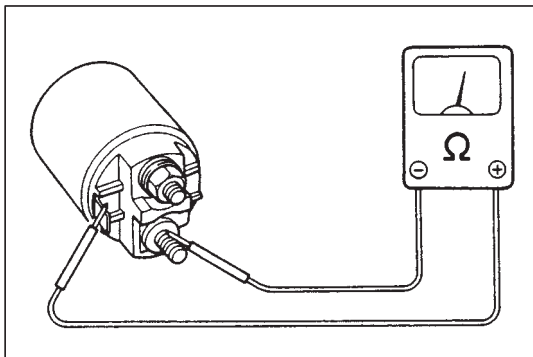

#### ◦ Pull-In Coil Open Circuit Test

Check for continuity across magnetic switch 'S' terminal and 'M' terminal. If no continuity exists, coil is open and should be replaced.

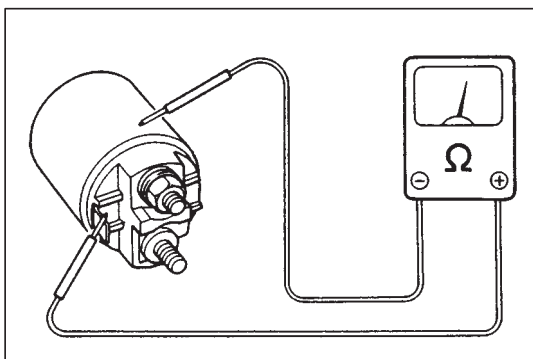

#### ◦ Hold-In Coil Open Circuit Test

Check for continuity across magnetic switch 'S' terminal and coil case. If no continuity exists, coil is open and should be replaced.

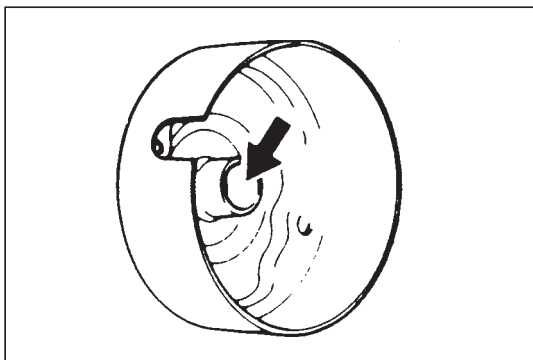

### 3. ARMATURE SHAFT BUSH

Inspect bush for wear or damage. Replace if necessary.

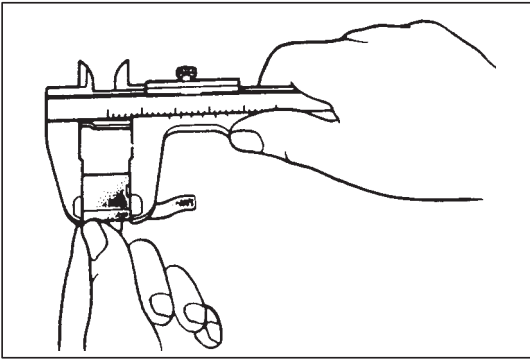

#### 4. BRUSH

- Check brushes for wear.

Measure length of brushes and if below limit, replace brush.

##### Brush length

	0.9 kW and 1.2 kW types	1.4 kW type
Standard	12.3 mm (0.44 in.)	16.5 mm (0.65 in.)
Limit	7 mm (0.28 in.)	

- Install brushes to each brush holder and check for smooth movement.

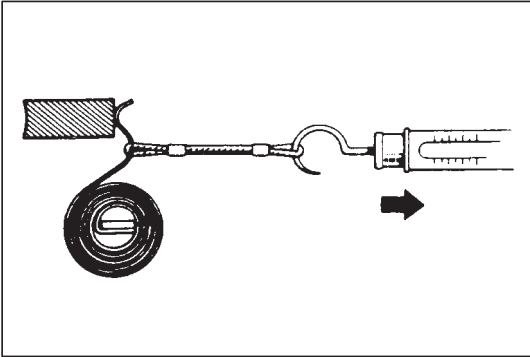

#### 5. SPRING

Inspect brush springs for wear, damage or other abnormal conditions. Replace if necessary.

##### Brush spring tension

Standard	1.9 – 2.5 kg (3.97 lb)
Limit	0.6 kg (1.32 lb)

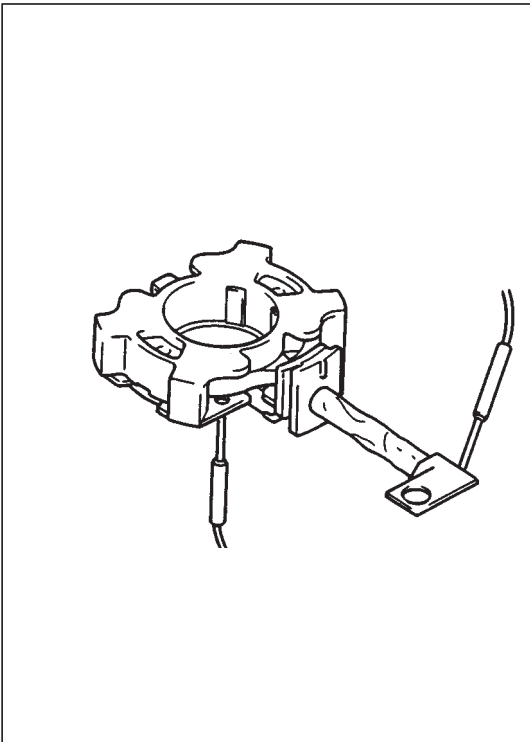

#### 6. BRUSH HOLDER

- Check movement of brush in brush holder. If brush movement within brush holder is sluggish, check brush holder for distortion and sliding faces for contamination. Clean or correct as necessary.
- Check for continuity across brush positive terminal and grounded brush holder. If continuity exists, brush holder is grounded due to defective insulation and should be replaced.

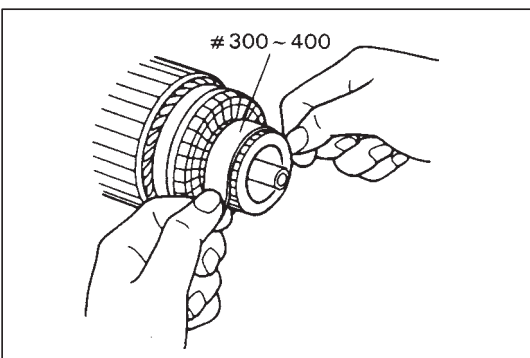

#### 7. ARMATURE

- Inspect commutator for dirt or burn. Correct with sandpaper or lathe, if necessary.

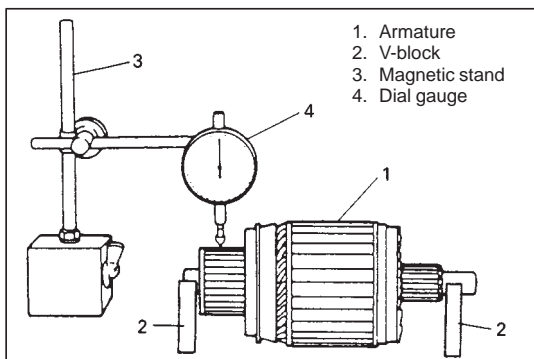

- Check commutator for uneven wear with armature supported on V-blocks. If deflection of dial gauge pointer exceeds limit, repair or replace.

**NOTE:**

Below specification presupposes that armature is free from bend. Bent armature must be replaced.

**Commutator out of round**

**Standard : 0.05 mm (0.002 in.) or less**

**Limit : 0.4 mm (0.015 in.)**

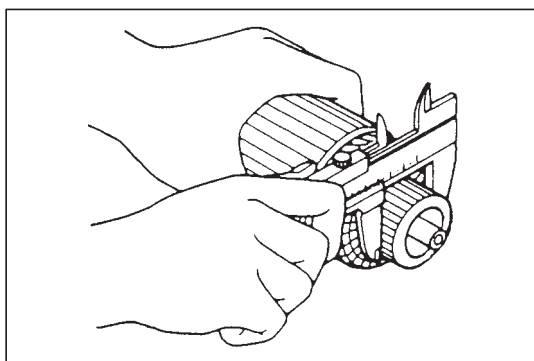

- Inspect commutator for wear. If diameter is below limit, replace armature.

**Commutator outside diameter**

**Standard : 29.4 mm (1.16 in.)**

**Limit : 28.8 mm (1.13 in.)**

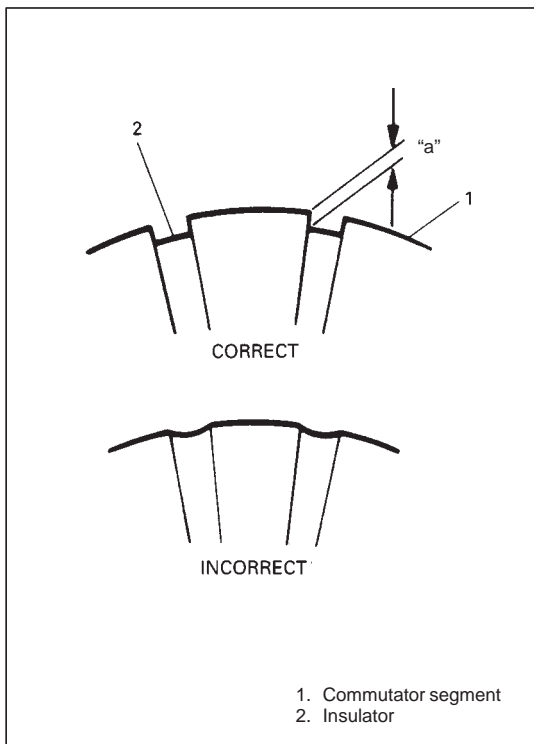

- Inspect commutator for insulator depth. Correct or replace if below limit.

**Commutator insulator depth "a"**

**Standard : 0.4 – 0.6 mm (0.015 – 0.023 in.)**

**Limit : 0.2 mm (0.008 in.)**

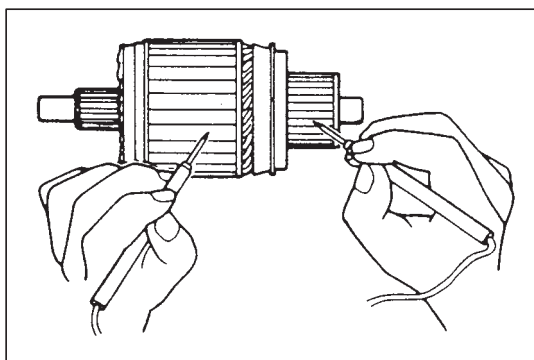

◦ **Ground Test**

Check commutator and armature core. If there is continuity, armature is grounded and must be replaced.

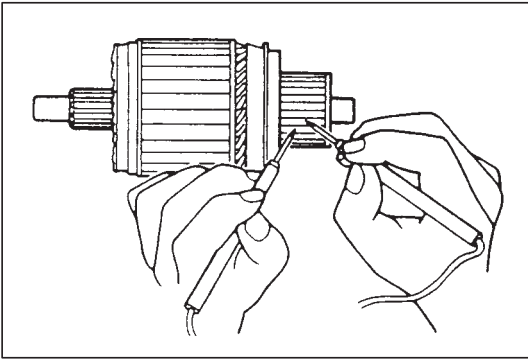

#### ◦ **Open Circuit Test**

Check for continuity between segments. If there is no continuity at any test point, there is an open circuit and armature must be replaced.

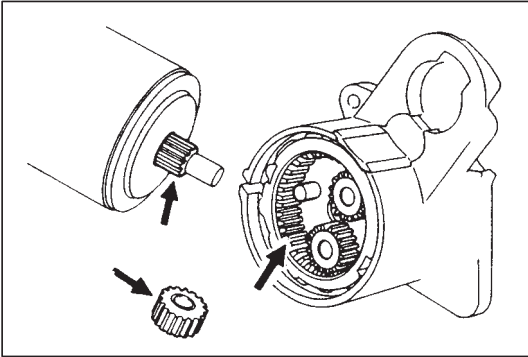

### **8. GEARS**

Inspect internal gear and planetary gears for wear, damage or other abnormal conditions. Replace if necessary.

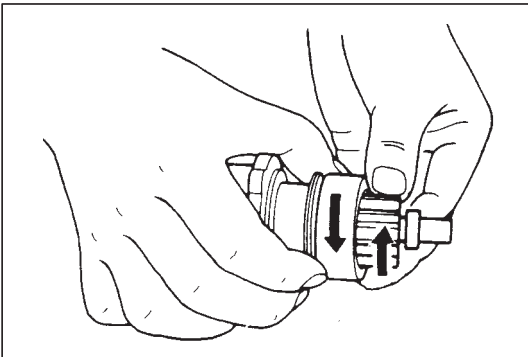

### **9. PINION AND OVER-RUNNING CLUTCH**

◦ Inspect pinion for wear, damage or other abnormal conditions. Check that clutch locks up when turned in direction of drive and rotates smoothly in reverse direction. Replace if necessary.

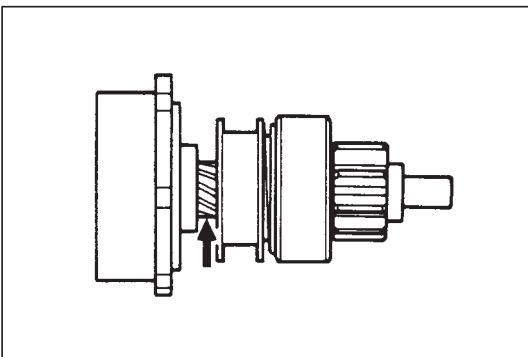

◦ Inspect spline teeth for wear or damage. Replace if necessary. Inspect pinion for smooth movement.

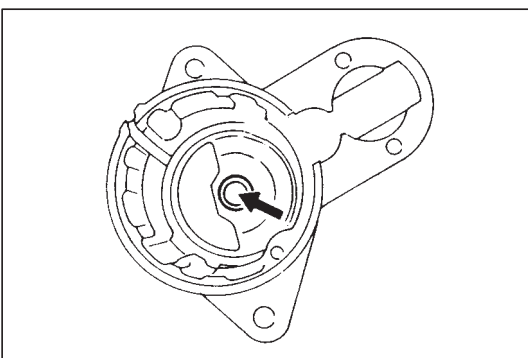

### **10. FRONT HOUSING BUSH**

Inspect bush for wear or damage. Replace if necessary.

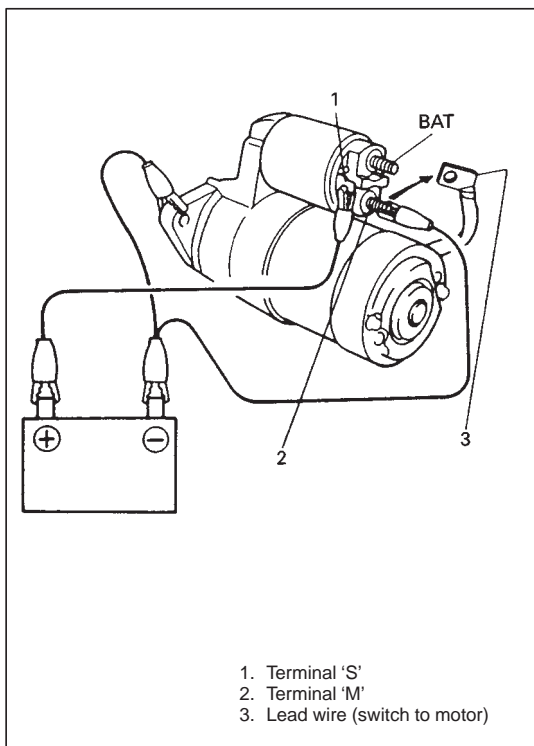

## PERFORMANCE TEST

### CAUTION:

Each test must be performed within 3 – 5 seconds to avoid coil from burning.

#### 1) Pull-In Test

Connect battery to magnetic switch as shown. Check that plunger and pinion move outward. If plunger and pinion don't move, replace magnetic switch.

### NOTE:

Before testing, disconnect lead wire from terminal M.

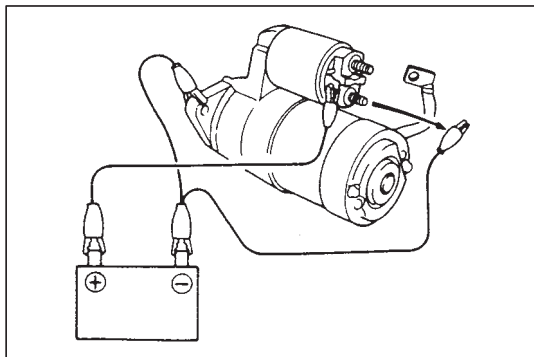

#### 2) Hold-In Test

While connected as above with plunger out, disconnect negative lead from terminal 'M'. Check that plunger and pinion remain out. If plunger and pinion return inward, replace magnetic switch.

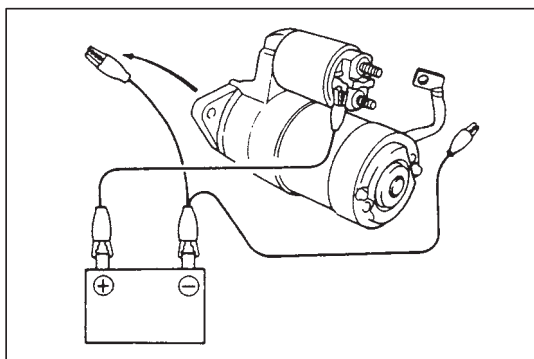

#### 3) Plunger and Pinion Return Test

Disconnect negative lead from switch body. Check that plunger and pinion return inward. If plunger and pinion don't return, disassemble and inspect starting motor.

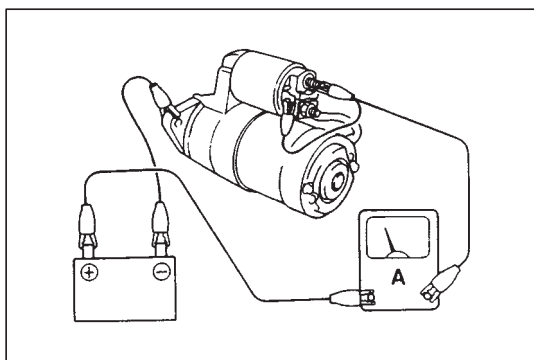

#### 4) No-Load Performance Test

- Connect battery and ammeter to starter as shown.
- Check that starter rotates smoothly and steadily with pinion moving out. Check that ammeter indicates specified current.

**Specified current: 90A MAX. at 11V**

### NOTE:

Use wires as thick as possible and tighten each terminal fully.

## SPECIFICATIONS

### 1.2 kW type (1.4 kW type)

Voltage		12 volts	
Output		1.2 kW (1.4 kW)	
Rating		30 seconds	
Direction of rotation		Clockwise as viewed from pinion side	
Brush length		12.3 mm (0.44 in.) (16.5 mm (0.65 in.))	
Number of pinion teeth		8	
Performance		Condition	Guarantee
Around at 20 °C (68 °F)	No load characteristic	11.0 V	90 A maximum 2,500 rpm minimum (3,000 rpm minimum)
	Load characteristic	7.5 V (7.7 V) 300 A	10.5 N·m (1.05 kg-m, 7.59 lb-ft) minimum 880 rpm minimum ( 9.81 N·m (0.98 kg-m, 7.0 lb-ft) minimum ) 1,000 rpm minimum
	Locked characteristic	4.0 V	760 A maximum 19.5 N·m (1.95 kg-m, 14.1 lb-ft) minimum ( 980 A maximum 23 N·m (2.3 kg-m, 16.5 lb-ft) minimum )
	Magnetic switch operating voltage		8 volts maximum

### 0.9 kW type

Voltage		12 volts	
Output		0.9 kW	
Rating		30 seconds	
Direction of rotation		Clockwise as viewed from pinion side	
Brush length		12.3 mm (0.44 in.)	
Number of pinion teeth		8	
Performance		Condition	Guarantee
Around at 20 °C (68 °F)	No load characteristic	11.0 V	90 A maximum 2,800 rpm minimum
	Load characteristic	8 V 200 A	4.8 N·m (0.48 kg-m, 3.5 lb-ft) minimum 1,260 rpm minimum
	Locked characteristic	3.5 V	550 A maximum 12.2 N·m (1.22 kg-m, 8.9 lb-ft) minimum
	Magnetic switch operating voltage		8 volts maximum

## REQUIRED SERVICE MATERIAL

MATERIAL	RECOMMENDED SUZUKI PRODUCT	USE
Lithium grease	SUZUKI SUPER GREASE A (99000-25010)	<ul style="list-style-type: none"><li>◦ Front and rear bush.</li><li>◦ Plunger.</li><li>◦ Pinion drive lever.</li><li>◦ Internal gear.</li><li>◦ Planetary carrier shaft.</li><li>◦ Planetary gear</li><li>◦ Ball</li></ul>

## SPECIAL TOOL



# SECTION 6G1

## CRANKING SYSTEM

### (0.9 kW No-Reduction Type)

#### CONTENTS

<b>GENERAL DESCRIPTION</b> .....	6G1-2	Inspection .....	6G1- 8
Cranking Circuit .....	6G1-2	Performance Test .....	6G1-12
Starting Motor .....	6G1-2	Pull-in test .....	6G1-12
<b>DIAGNOSIS</b> .....	6G1-4	Hold-in test .....	6G1-12
<b>UNIT REPAIR OVERHAUL</b> .....	6G1-6	Check pinion return .....	6G1-12
Dismounting .....	6G1-6	No-load performance test .....	6G1-12
Remounting .....	6G1-6	<b>SPECIFICATIONS</b> .....	6G1-13
Disassembly .....	6G1-7	<b>REQUIRED SERVICE MATERIAL</b> .....	6G1-13
Reassembly .....	6G1-8	<b>SPECIAL TOOL</b> .....	6G1-13

## GENERAL DESCRIPTION

### CRANKING CIRCUIT

The cranking circuit consists of the battery, starting motor, ignition switch, and related electrical wiring. These components are connected electrically as shown below.

Only the starting motor will be covered in this section.

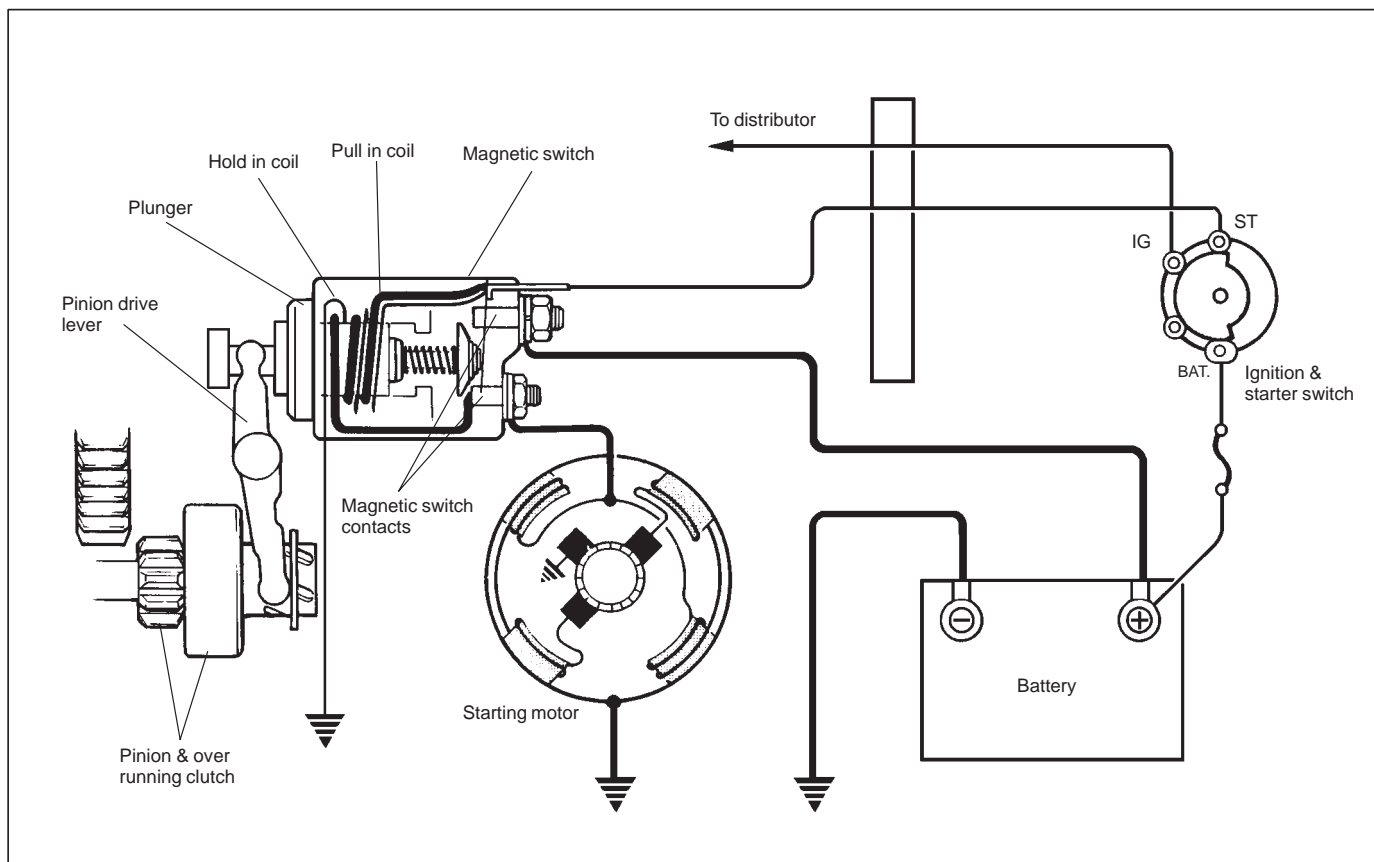

### STARTING MOTOR

The starting motor consists of parts shown on the following page and has field coils mounted in the starting motor yoke (frame). The magnetic switch assembly and parts in the starting motor are enclosed in housings so that they will be protected against possible dirt and water splash.

In the circuit shown above, the magnetic (motor) switch coils are magnetized when the ignition switch is closed. The resulting plunger and pinion drive lever movement causes the pinion to engage the engine flywheel gear and the magnetic switch main contacts to close, and cranking takes place. When the engine starts, the pinion overrunning clutch protects the armature from excessive speed until the switch is opened, at which time the return spring causes the pinion to disengage.

#### NOTE:

- Starting motor does not require lubrication except during overhaul.
- Make sure to apply grease before assembly where so indicated "A" in the figure below.

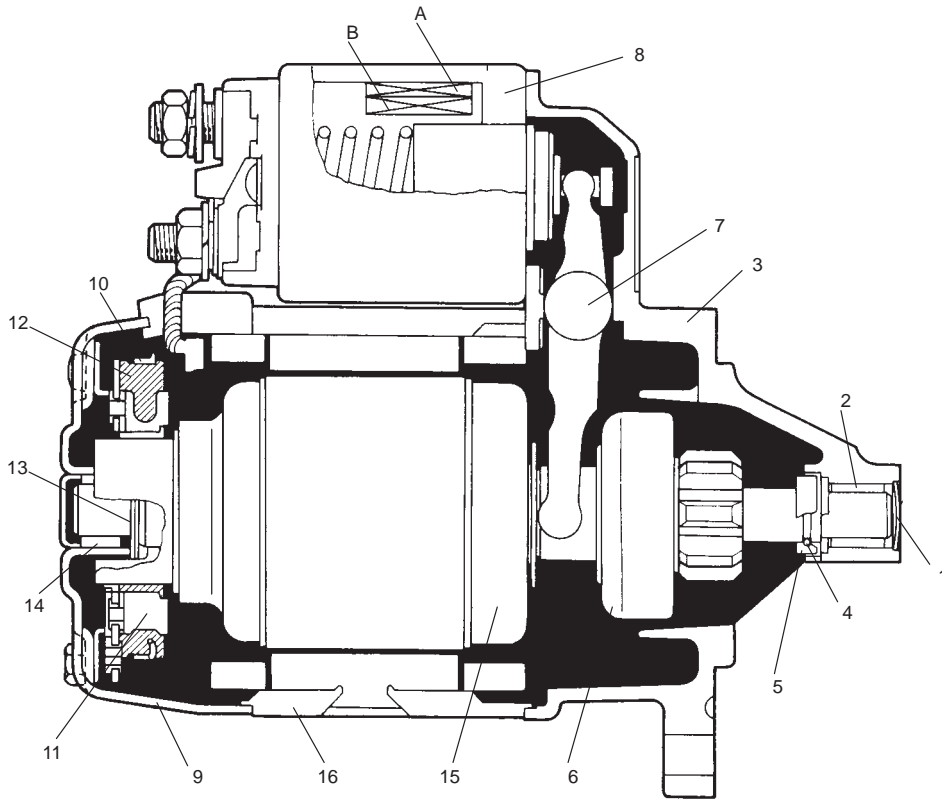

1. Drive housing cover
2. Drive bush
3. Drive housing
4. Armature ring
5. Armature stop ring
6. Over running clutch
7. Pinion drive lever
8. Magnetic switch
9. Commutator end cover
10. Brush spring
11. Brush holder
12. Brush
13. Washer
14. Commutator end bushing
15. Armature
16. Starting motor yoke
- A: Hold-in coil
- B: Pull-in coil

**"A" : Apply grease (99000-25010)**

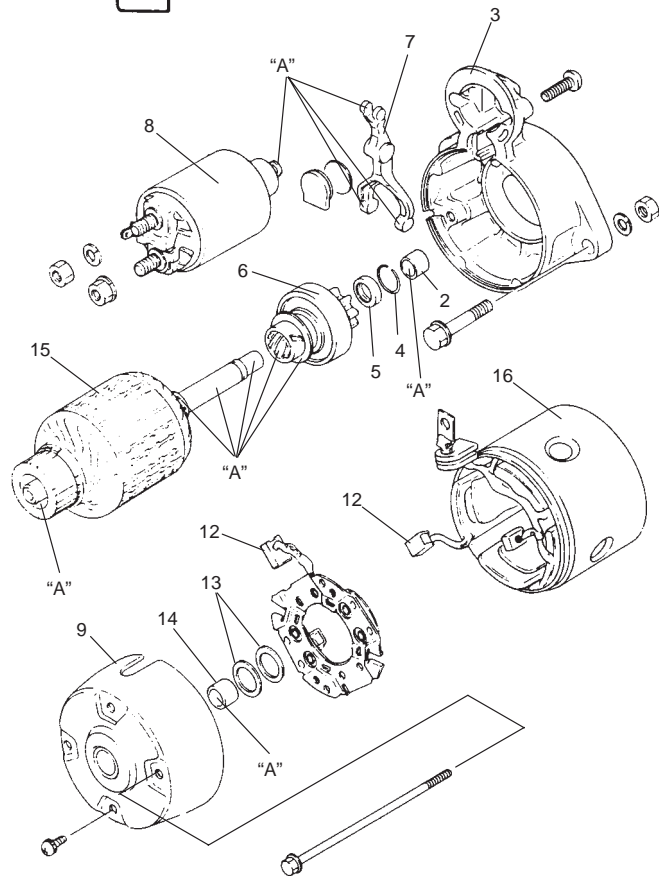

## DIAGNOSIS

Possible symptoms due to starting system trouble would be as follows:

- Starting motor does not run (or runs slowly)
- Starting motor runs but fails to crank engine
- Abnormal noise is heard

Proper diagnosis must be made to determine exactly where the cause of each trouble lies ..... in battery, wiring harness, (including ignition and starter switch), starting motor or engine.

Do not remove motor just because starting motor does not run. Check following items and narrow down scope of possible causes.

- 1) Condition of trouble
- 2) Tightness of battery terminals (including ground cable connection on engine side) and starting motor terminals
- 3) Discharge of battery
- 4) Mounting of starting motor

Condition	Possible Cause	Correction
<b>Motor not running</b>	<b>No operating sound of magnetic switch</b> <ul style="list-style-type: none"> <li>● Battery run down</li> <li>● Battery voltage too low due to battery deterioration</li> <li>● Poor contact in battery terminal connection</li> <li>● Loose grounding cable connection</li> <li>● Fuse set loose or blown off</li> <li>● Poor contacting action of ignition switch and magnetic switch</li> <li>● Lead wire coupler loose in place</li> <li>● Open-circuit between ignition switch and magnetic switch</li> <li>● Open-circuit in pull-in coil</li> <li>● Poor sliding of plunger and/or pinion</li> <li>● Shift lever switch is not in P or N, or not adjusted (A/T)</li> <li>● Brushes are seating poorly or worn down</li> </ul>	Recharge battery. Replace battery.  Retighten or replace.  Retighten. Tighten or replace. Replace.  Retighten. Repair.  Replace magnetic switch. Repair. Shift in P or N, or adjust switch.  Repair or replace.
	<b>Operating sound of magnetic switch heard</b> <ul style="list-style-type: none"> <li>● Battery run down</li> <li>● Battery voltage too low due to battery deterioration</li> <li>● Loose battery cable connections</li> <li>● Burnt main contact point, or poor contacting action of magnetic switch</li> <li>● Brushes are seating poorly or worn down</li> <li>● Weakened brush spring</li> <li>● Burnt commutator</li> <li>● Poor grounding of field coil</li> <li>● Layer short-circuit of armature</li> <li>● Crankshaft rotation obstructed</li> </ul>	Recharge battery. Replace battery.  Retighten. Replace magnetic switch.  Repair or replace.  Replace. Replace armature. Repair. Replace. Repair.

Condition	Possible Cause	Correction
<b>Starting motor running but too slow (small torque)</b>	<p><b>If battery and wiring are satisfactory, inspect starting motor</b></p> <ul style="list-style-type: none"> <li>● Insufficient contact of magnetic switch main contacts</li> <li>● Layer short-circuit of armature</li> <li>● Disconnected, burnt or worn commutator</li> <li>● Poor grounding of field coil</li> <li>● Worn brushes</li> <li>● Weakened brush springs</li> <li>● Burnt or abnormally worn end bush</li> </ul>	<p>Replace magnetic switch.</p> <p>Replace. Repair or replace.</p> <p>Repair. Replace brush. Replace spring. Replace bush.</p>
<b>Starting motor running, but not cranking engine</b>	<ul style="list-style-type: none"> <li>● Worn pinion tip</li> <li>● Poor sliding of over-running clutch</li> <li>● Over-running clutch slipping</li> <li>● Worn teeth of ring gear</li> </ul>	<p>Replace over-running clutch. Repair. Replace over-running clutch. Replace flywheel (M/T) or drive plate (A/T).</p>
<b>Noise</b>	<ul style="list-style-type: none"> <li>● Abnormally worn bush</li> <li>● Worn pinion or worn teeth of ring gear</li> <li>● Poor sliding of pinion (failure in return movement)</li> <li>● Lack of grease in each part</li> </ul>	<p>Replace bush. Replace over-running clutch or flywheel (M/T), drive plate (A/T). Repair or replace.</p> <p>Lubricate.</p>
<b>Starting motor does not stop running</b>	<ul style="list-style-type: none"> <li>● Fused contact points of magnetic switch</li> <li>● Short-circuit between turns of magnetic switch coil (layer short-circuit)</li> <li>● Failure of returning action in ignition switch</li> </ul>	<p>Replace magnetic switch.</p> <p>Replace magnetic switch.</p> <p>Replace.</p>

## UNIT REPAIR OVERHAUL

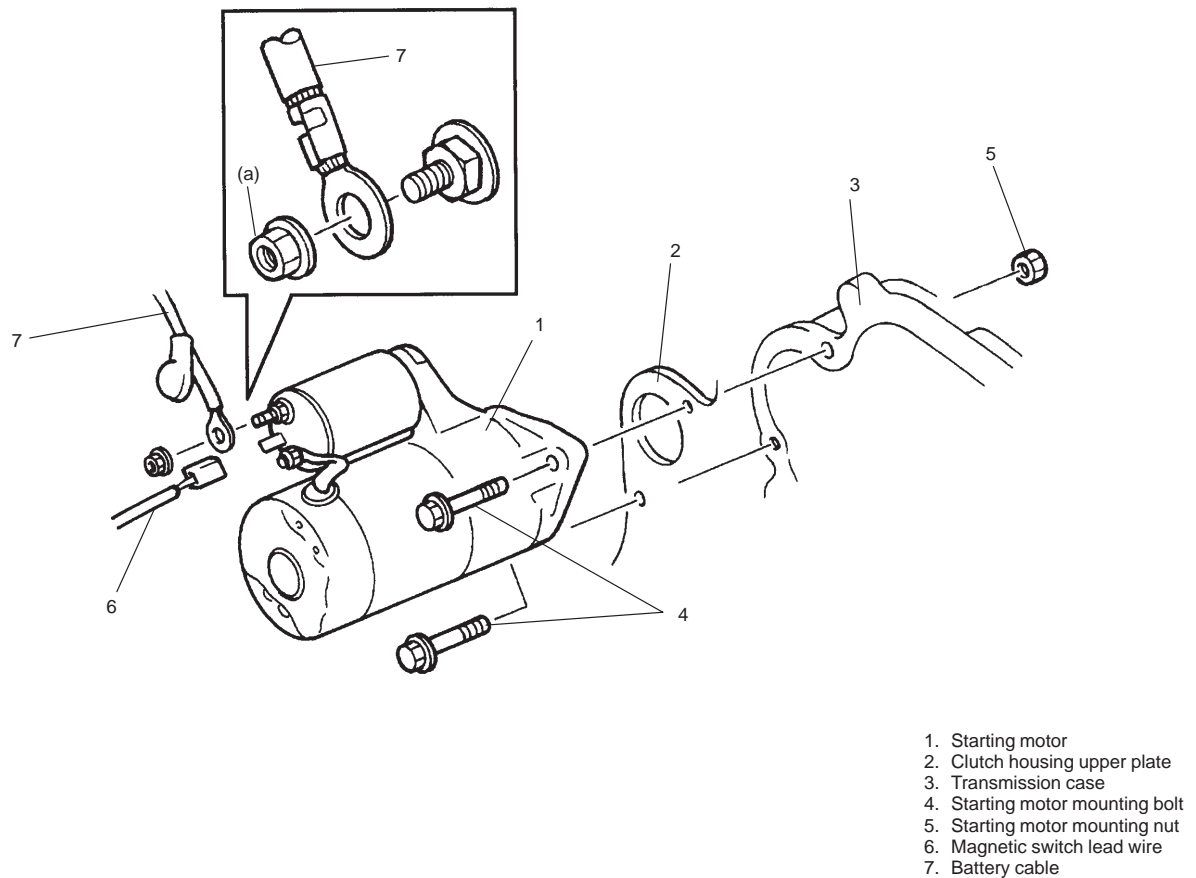

### DISMOUNTING

- 1) Disconnect negative battery lead at battery.
- 2) Disconnect magnetic switch lead wire and battery cable from starting motor.
- 3) Remove starting motor mounting bolts and nut.
- 4) Remove starting motor.

### REMOUNTING

Reverse the dismounting procedure.

#### Tightening Torque

(a): 11 N·m (1.1 kg-m, 8.0 lb-ft)

## DISASSEMBLY

### NOTE:

- Before disassembling starting motor, be sure to put match marks at two locations (A and B) as shown in the left figure so that any possible mistakes can be avoided.
- Do not clamp yoke in a vise or strike it with a hammer during disassembling and reassembling.

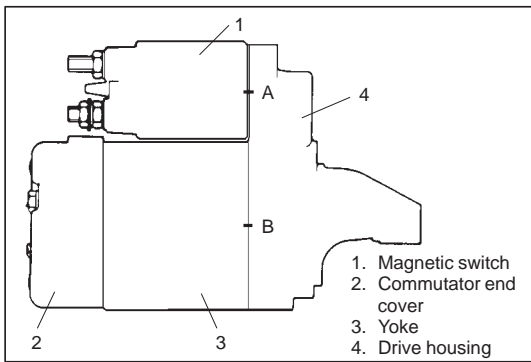

- 1) Remove nut securing the end of field coil lead to terminal on the head of magnetic switch.

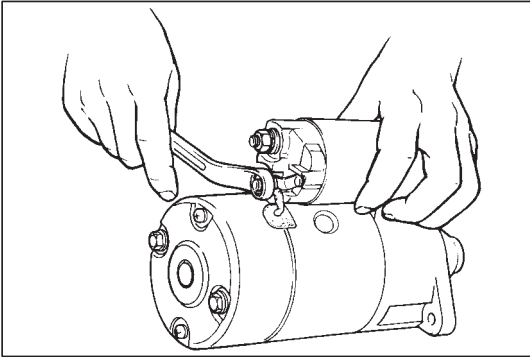

- 2) Take off magnetic switch from starting motor body by removing 2 mounting screws.

### NOTE:

**Don't disassemble this switch. If defective, replace as a complete assembly.**

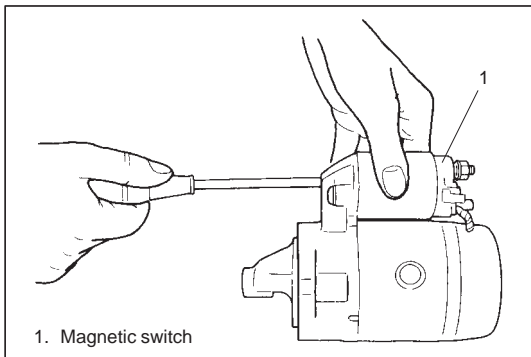

- 3) Loosen 2 bolts and 2 screws to remove commutator end cover.
- 4) Separate drive housing and armature from yoke.

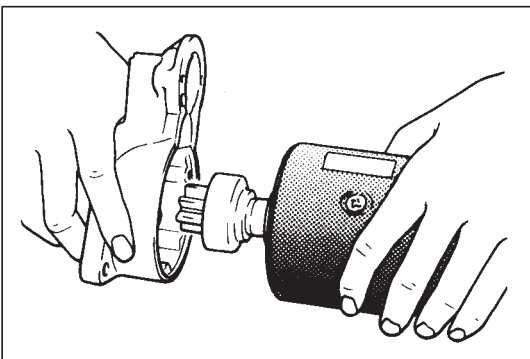

- 5) Draw brushes out of holder.

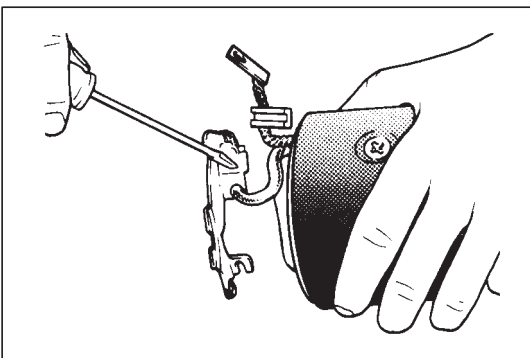

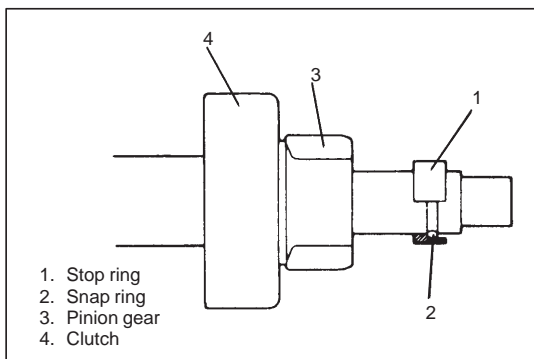

- 6) Draw off over running clutch, as follows:
- (1) Draw stop ring toward clutch side.
  - (2) Remove armature ring and side off clutch.

## REASSEMBLY

Assemble in reverse order of Disassembly, noting the following.

- 1) Apply grease. (Refer to page 6G1-3.)
- 2) Install pinion drive lever into drive housing, referring to 6G1-3 especially for its direction.
- 3) Upon completion of assembly, carry out "PERFORMANCE TEST". (Refer to page 6G1-12.)
- 4) Tighten battery cable nut to specified torque. (Refer to page 6G1-6)

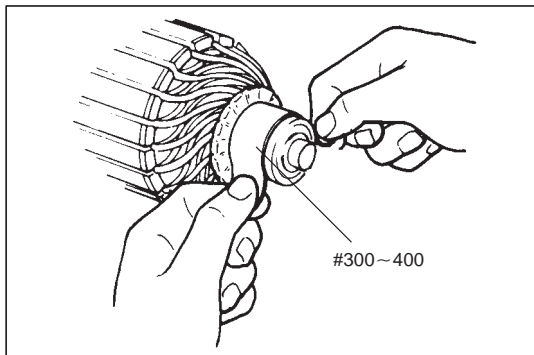

## INSPECTION

### 1. ARMATURE

- Inspect commutator for dirt or burn. Correct with sandpaper or lathe, if necessary.

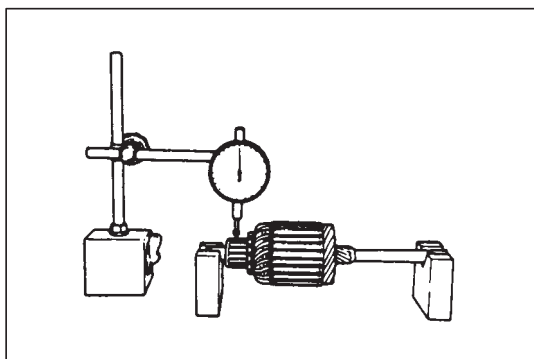

- Check commutator for uneven wear. If deflection of dial gauge pointer exceeds limit, repair or replace.

#### NOTE:

**Below specification presupposes that armature is free from bend. Bent shaft must be replaced.**

#### Commutator out round

**Standard: 0.05 mm (0.0019 in.) or less**

**Limit: 0.4 mm (0.015 in.)**

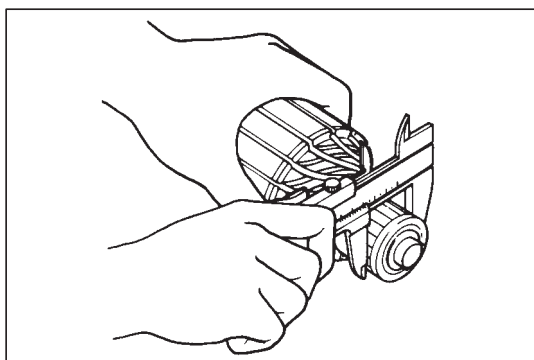

- Inspect commutator for wear.  
If below limit, replace armature.

#### Commutator outside diameter

**Standard: 32.0 mm (1.26 in.)**

**Limit: 31.4 mm (1.24 in.)**

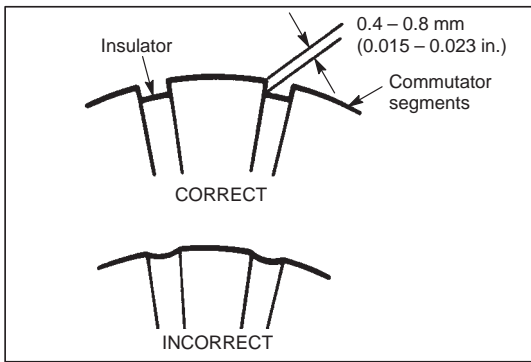

- Inspect commutator for insulator depth. Correct or replace if below limit.

#### Commutator mica depth

**Standard:** 0.4 – 0.6 mm (0.015 – 0.023 in.)

**Limit:** 0.2 mm (0.0078 in.)

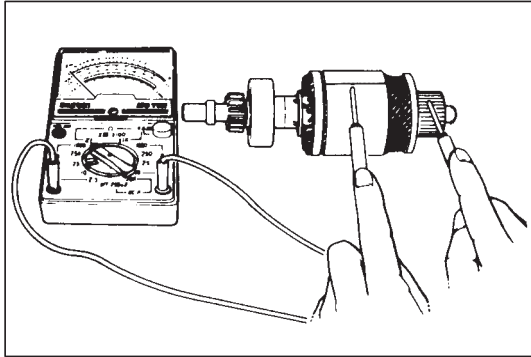

#### ● Ground test

Check commutator and armature core. If there is continuity, armature is grounded and must be replaced.

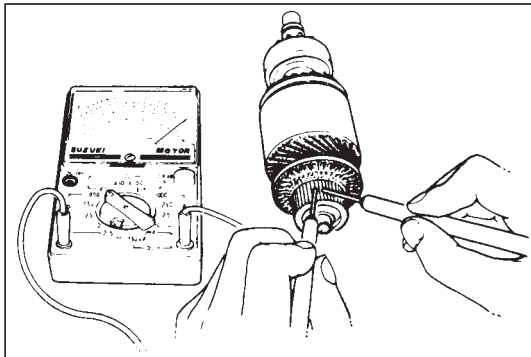

#### ● Open circuit test

Check for continuity between segments. If there is no continuity at any point, there is an open circuit and armature must be replaced.

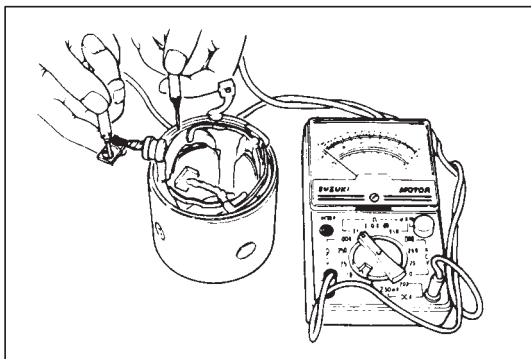

## 2. FIELD COIL

#### Ground test

Check continuity between brush and bare surface.

If there is continuity, field windings are grounded.

The yoke ass'y must be replaced.

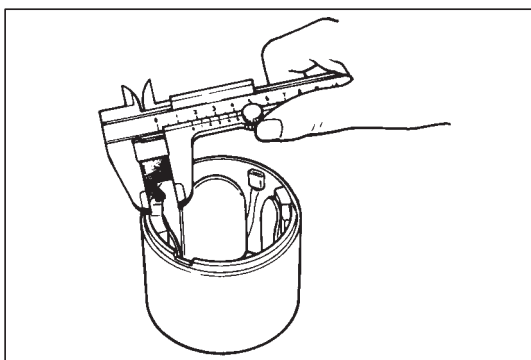

## 3. BRUSH

Check brushes for wear. If below limit, replace brush.

#### Brush length

**Standard:** 17.0 mm (0.67 in.)

**Limit:** 11.5 mm (0.45 in.)

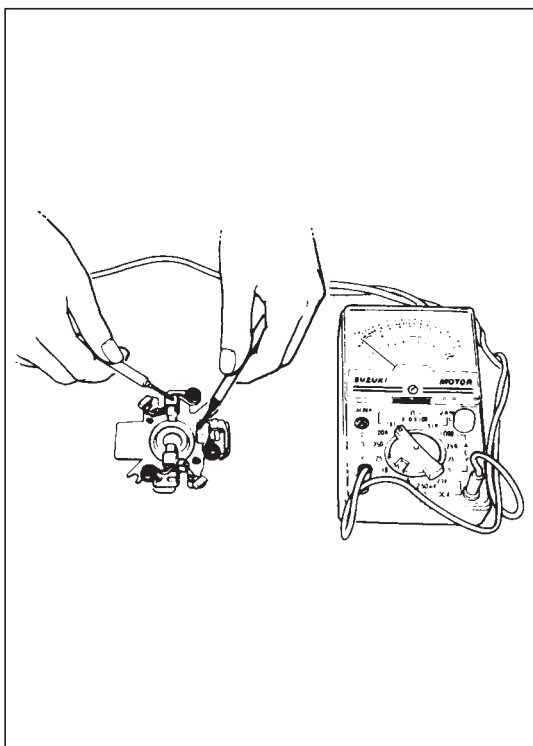

#### 4. BRUSH HOLDER

Check movement of brush in brush holder. If brush movement within brush holder is sluggish, check brush holder for distortion and sliding faces for correct contamination.

Clean or correct as necessary.

Clean for continuity across insulated brush holder (positive side) and grounded brush holder (negative side).

If continuity exists, brush holder is grounded due to defective insulation and should be replaced.

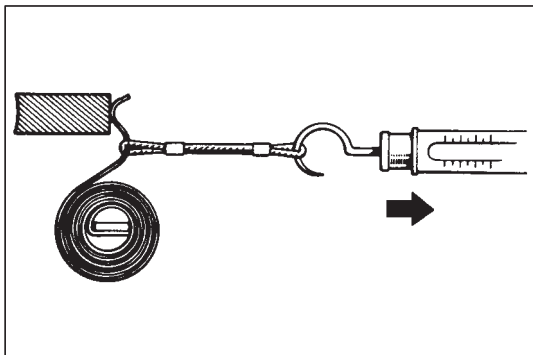

#### 5. SPRING

Inspect brush spring for wear, damage or other abnormal conditions. Replace if necessary.

##### Brush spring tension

Standard: 1.95 kg (4.3 lb)

Limit: 0.9 kg (1.98 lb)

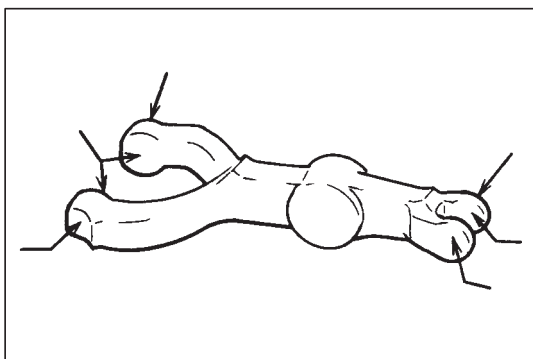

#### 6. DRIVE LEVER

Inspect drive lever for wear. Replace if necessary.

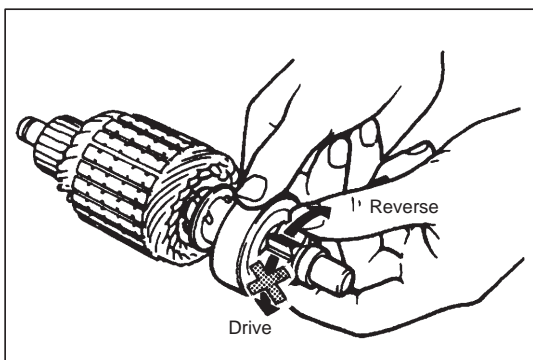

#### 7. PINION AND OVER-RUNNING CLUTCH

- Inspect pinion for wear, damage or other abnormal conditions. Check that clutch locks up when turned in direction of drive and rotates smoothly in reverse direction. Replace if necessary.

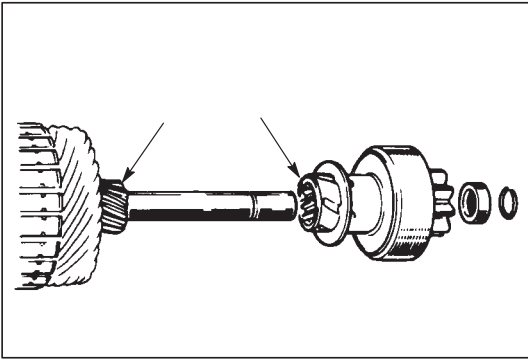

- Inspect spline teeth for wear or damage. Replace if necessary. Inspect pinion for smooth movement.

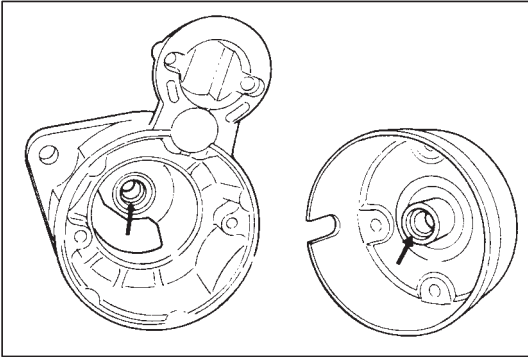

### 8. ARMATURE SHAFT BUSH

- Inspect bushes for wear or damage. Replace if necessary.

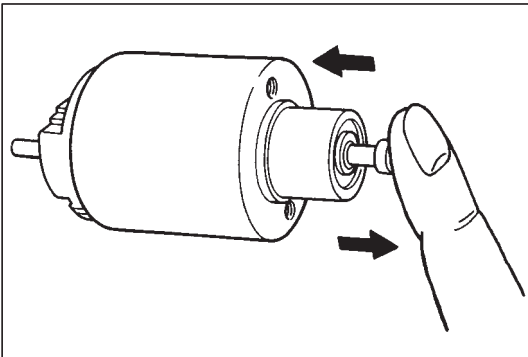

### 9. MAGNETIC SWITCH

- Push in plunger and release it. Plunger should return quickly to its original position. Replace if necessary.

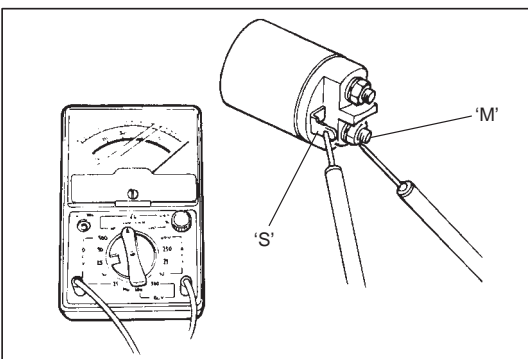

#### ● Pull-in coil open circuit test

- Check for continuity across magnetic switch 'S' terminal and 'M' terminal. If no continuity exists, coil is open and should be replaced.

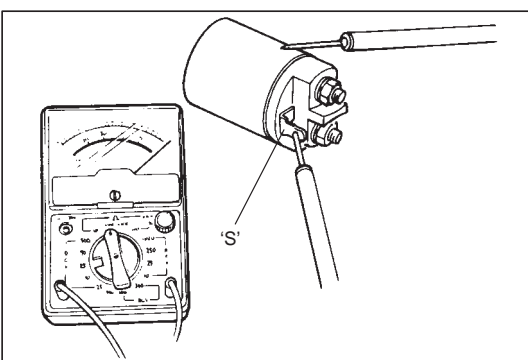

#### ● Hold-in coil open circuit test

- Check for continuity across magnetic switch 'S' terminal and coil case. If no continuity exists, coil is open and should be replaced.

## PERFORMANCE TEST

### CAUTION:

These tests must be performed within 3 - 5 seconds to avoid coil from burning.

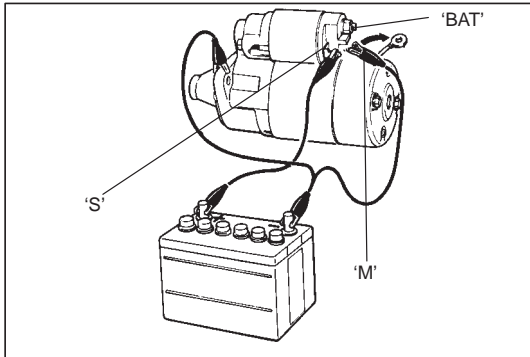

### ● PULL-IN TEST

Connect battery to magnetic switch as shown.  
Check that pinion moves outward.  
If pinion does not move, replace magnetic switch.

### NOTE:

Before testing, disconnect field coil lead from Terminal 'M'.

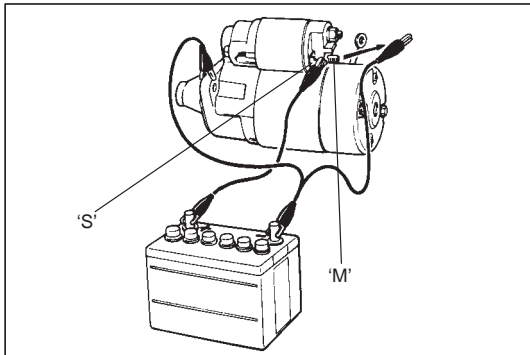

### ● HOLD-IN TEST

While connected as left figure with pinion out, disconnect negative lead from terminal 'M'.  
Check that pinion remains out.  
If pinion returns inward, replace magnetic switch.

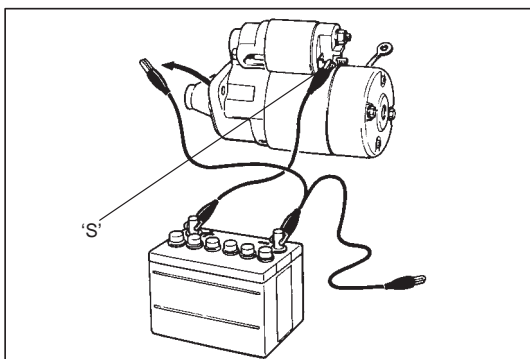

### ● CHECK PINION RETURN

Disconnect negative lead from magnetic switch body.  
Check that pinion returns inward.  
If pinion does not return, replace magnetic switch.

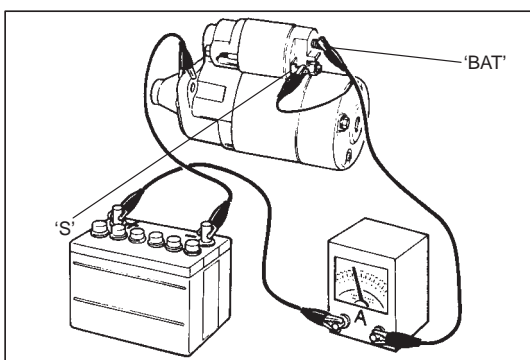

### ● NO-LOAD PERFORMANCE TEST

- Connect battery and ammeter to starter as shown.
- Check that starter rotates smoothly and steadily with pinion moving out. Check that ammeter reads specified current.

**Specified current: Less than 60 A at 11.5 V**

## SPECIFICATIONS

Voltage		12 volts	
Output		0.9 kW	
Rating		30 seconds	
Direction of rotation		Clockwise as viewed from pinion side	
Brush length		17.0 mm (0.67 in.)	
Number of pinion teeth		8	
Performance		Condition	Guarantee
Around at 20°C (68°F)	No load characteristic	11.5V	60 A maximum 6600 rpm minimum
	Load characteristic	9 V 150 A	2.8 N·m (0.28 kg-m, 2.0 lb-ft) 1900 rpm minimum
	Locked rotor current	5 V	500 A maximum 11.3 N·m (1.13 kg-m, 8.2 lb-ft) minimum
	Magnetic switch operating voltage		8 volts maximum

## REQUIRED SERVICE MATERIAL

MATERIAL	RECOMMENDED SUZUKI PRODUCT	USE
Lithium grease	SUZUKI SUPER GREASE A (99000-25010)	<ul style="list-style-type: none"> <li>● Armature shaft.</li> <li>● Over-running clutch.</li> <li>● Commutator end cap.</li> <li>● Drive lever.</li> </ul>

## SPECIAL TOOL

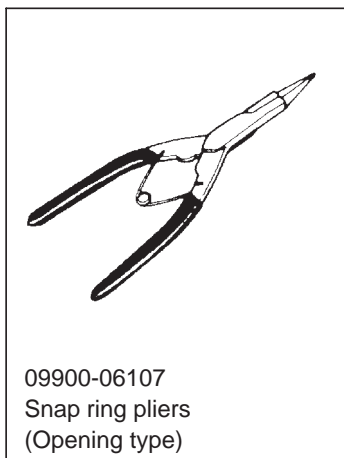

## SECTION 6H

# CHARGING SYSTEM

**WARNING:**

For vehicles equipped with Supplemental Restraint (Air Bag) System

- Service on and around the air bag system components or wiring must be performed only by an authorized SUZUKI dealer. Refer to “Air Bag System Components and Wiring Location View” under “General Description” in air bag system section in order to confirm whether you are performing service on or near the air bag system components or wiring. Please observe all WARNINGS and “Service Precautions” under “On-Vehicle Service” in air bag system section before performing service on or around the air bag system components or wiring. Failure to follow WARNINGS could result in unintentional activation of the system or could render the system inoperative. Either of these two conditions may result in severe injury.
- Technical service work must be started at least 90 seconds after the ignition switch is turned to the “LOCK” position and the negative cable is disconnected from the battery. Otherwise, the system may be activated by reserve energy in the Sensing and Diagnostic Module (SDM).

## CONTENTS

6H

<b>GENERAL DESCRIPTION</b> .....	6H- 2
BATTERY .....	6H- 2
GENERATOR .....	6H- 4
<b>DIAGNOSIS</b> .....	6H- 6
BATTERY .....	6H- 6
GENERATOR .....	6H- 8
<b>ON-VEHICLE SERVICE</b> .....	6H-11
BATTERY .....	6H-11
Jump Starting in Case of Emergency .....	6H-11
Dismounting .....	6H-12
Handling .....	6H-12
Remounting .....	6H-12
GENERATOR .....	6H-13
Generator Belt .....	6H-13
<b>UNIT REPAIR OVERHAUL</b> .....	6H-14
GENERATOR .....	6H-14
Dismounting .....	6H-14
Remounting .....	6H-15
Disassembly .....	6H-16
Inspection .....	6H-22
Replace Brush .....	6H-26
Reassembly .....	6H-27
<b>SPECIFICATIONS</b> .....	6H-31
BATTERY .....	6H-31
GENERATOR .....	6H-31
<b>TIGHTENING TORQUE SPECIFICATIONS</b> .....	6H-31

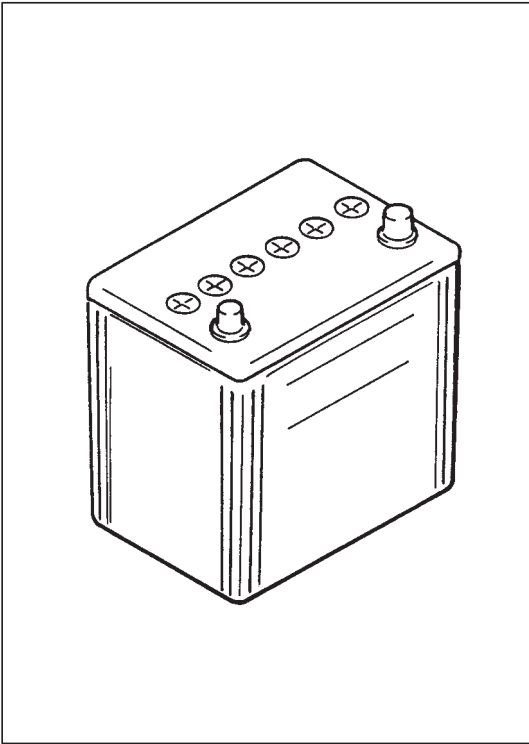

## GENERAL DESCRIPTION

### BATTERY

The battery has three major functions in the electrical system.

- It is a source of electrical energy for cranking the engine.
- It acts as a voltage stabilizer for the electrical system.
- It can, for a limited time, provide energy when the electrical load exceeds the output of the generator.

### CARRIER AND HOLD-DOWN

The battery carrier should be in good condition so that it will support the battery securely and keep it level.

Before installing the battery, the battery carrier and hold-down clamp should be clean and free from corrosion and make certain there are no parts in carrier.

To prevent the battery from shaking in its carrier, the hold-down bolts should be tight enough but not over-tightened.



### ELECTROLYTE FREEZING

The freezing point of electrolyte depends on its specific gravity. Since freezing may ruin a battery, it should be protected against freezing by keeping it in a fully charged condition. If a battery is frozen accidentally, it should not be charged until it is warmed.

### SULFATION

If the battery is allowed to stand for a long period in discharged condition, the lead sulfate becomes converted into a hard, crystalline substance, which will not easily turn back to the active material again during the subsequent recharging. "Sulfation" means the result as well as the process of that reaction.

Such a battery can be revived by very slow charging and may be restored to usable condition but its capacity is lower than before.

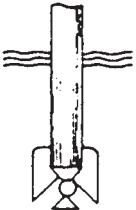
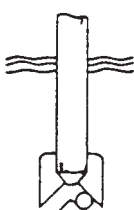
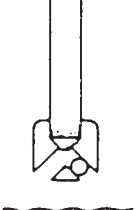
D I A G N O S I S	OK	CHARGING NECESSARY	LOW LEVEL ELECTROLYTE REPLACE BATTERY
I N D I C A T O R	Green dot 	Dark 	Clear 
G R A V I T Y B A L L			

### BUILT-IN INDICATOR (IF EQUIPPED)

The battery has a built-in temperature compensated indicator in the top of the battery. This indicator is to be used with the following diagnostic procedure. When checking the indicator, make sure that the battery has a clean top. A light may be needed in some poorly-lit areas.

Three types of indication available under normal operation are as follows.

#### 1. Green Dot

Battery is sufficiently charged for testing.

#### 2. Dark

Battery must be charged before testing.

If there is a cranking complaint, battery should be tested as described in Diagnosis section. Charging and electrical systems should also be checked at this time.

#### 3. Clear or Light Yellow

This means that fluid level is below the bottom of hydrometer. Its possible cause is excessive or prolonged charging, a broken case, excessive tipping or normal battery deterioration.

When the battery is found in such condition, it is possible that high charging voltage is caused by the faulty charging system and therefore, charging and electrical systems need to be checked. If there is a trouble in cranking and its cause lies in the battery, it should be replaced.

## CARE OF BATTERY

**WARNING:**

- **Never expose battery to open flame or electric spark because of battery generate gas which is flammable and explosive.**
- **Do not allow battery fluid to contact eyes, skin, fabrics, or painted surfaces as fluid is a corrosive acid. Flush any contacted area with water immediately and thoroughly.**
- **Batteries should always be kept out of reach of children.**

- 1) The battery is a very reliable component, but needs periodical attentions.
  - Keep the battery carrier clean
  - Prevent rust formation on the terminal posts
  - Keep the electrolyte up to the upper level uniformly in all cells.

When keeping battery on vehicle over a long period of time, follow instructions given below.

- Weekly, start the engine and run it until it reaches normal operating temperature with engine speed of 2000 to 3000 rpm. Make sure all electric switches are off before storing the vehicle.
- Recharge the battery twice a month to prevent it from discharging excessively. This is especially important when ambient temperature is low.

The battery discharges even when it is not used, while vehicles are being stored. Battery electrolyte can freeze and battery case can crack at cold ambient condition if battery is not properly charged.

- 2) Keep the battery cable connections clean.

The cable connections, particularly at the positive (+) terminal post, tend to become corroded. The product of corrosion, or rust, on the mating faces of conductors resists the flow of current. Clean the terminals and fittings periodically to ensure good metal-to-metal contact, and grease the connections after each cleaning to protect them against rusting.

- 3) Be always in the know as to the state of charge of the battery.

The simplest way to tell the state of charge is to carry out a hydrometer test. The hydrometer is an instrument for measuring the specific gravity (S.G.) of the battery electrolyte. The S.G. of the electrolyte is indicative of the state of charge. Refer to "DIAGNOSIS" of BATTERY in this section.

## GENERATOR

The generator is a small and high performance type with an IC regulator incorporated. The internal components are connected electrically as shown below figure.

The generator features are as follows:

- Solid state regulator is mounted inside the generator.
- All regulator components are enclosed into a solid mold.
- This unit along with the brush holder assembly is attached to the rear housing.
- The IC regulator uses integrated circuits and controls the voltage produced by the generator, and the voltage setting cannot be adjusted.
- The generator rotor bearings contain enough grease to eliminate the need for periodic lubrication. Two brushes carry current through the two slip rings to the field coil mounted on the rotor, and under normal conditions will provide long period of attention-free service.
- The stator windings are assembled on the inside of a laminated core that forms part of the generator frame.
- A condenser mounted in the rear housing suppresses radio noise.

### NOTE:

The generator used in each vehicle is one of the following three types, depending on specification.

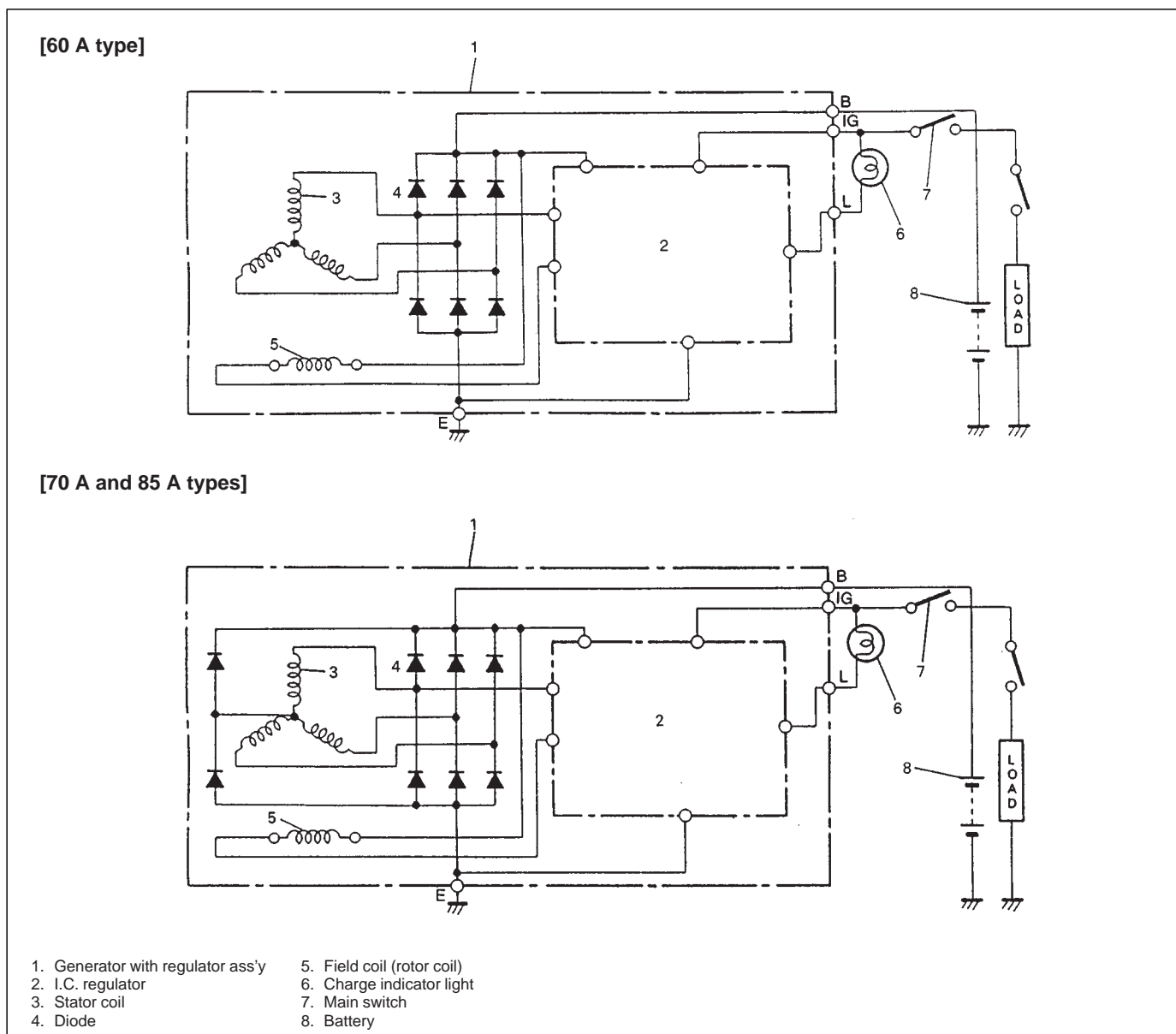

[60 A type]

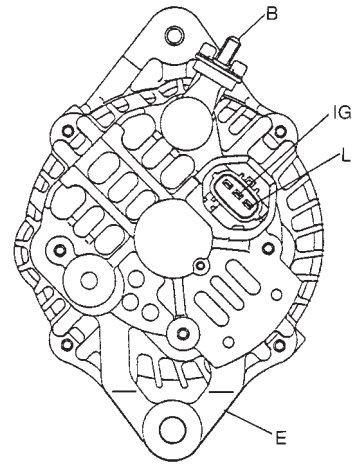
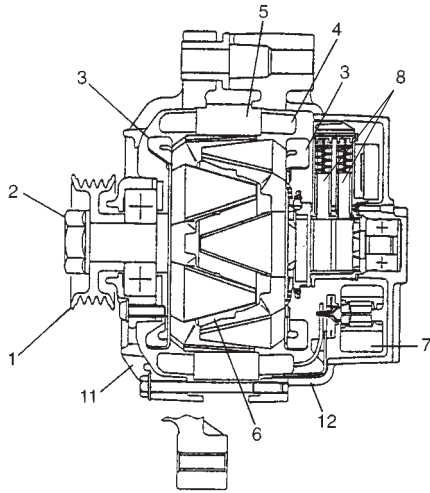

[70 A type]

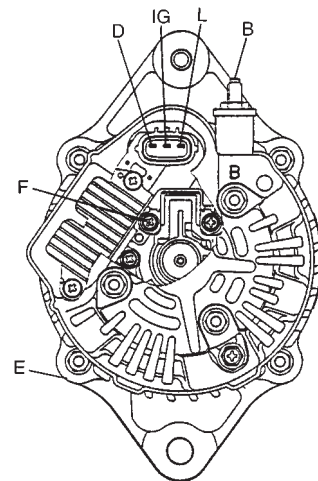
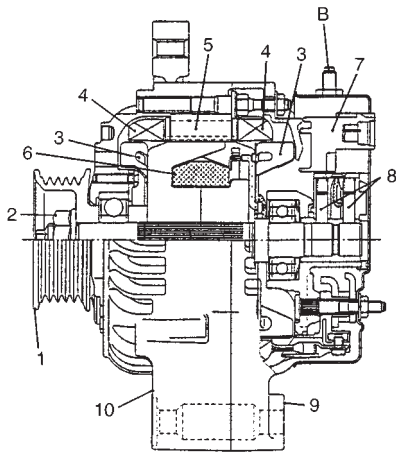

[85 A type]

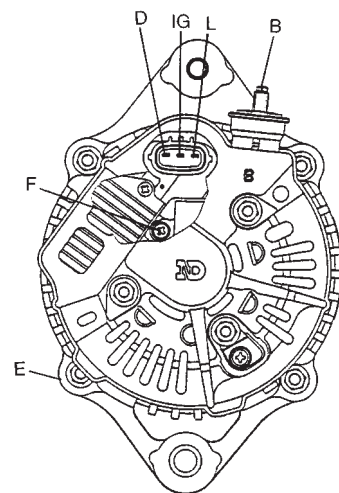
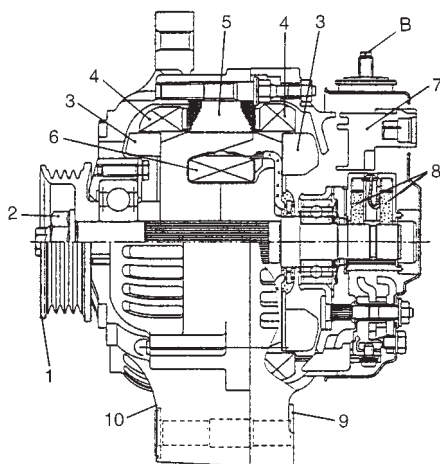

- 1. Pulley
- 2. Pulley nut
- 3. Rotor fan
- 4. Stator coil
- 5. Stator core
- 6. Field coil

- 7. Regulator
- 8. Brush
- 9. Rear end frame
- 10. Drive end frame
- 11. Front housing
- 12. Rear housing

- B : Generator output (Battery terminal)
- D : Dummy terminal
- E : Ground
- F : Field coil terminal
- IG : Ignition terminal
- L : Lamp terminal

## DIAGNOSIS

### BATTERY

#### COMMON CAUSES OF FAILURE

A battery is not designed to last indefinitely; however, with proper care, it will provide many years of service. If the battery performs satisfactorily during test but fails to operate properly for no apparent reason, the following are some factors that may point to the cause of trouble:

- Accessories left on overnight or for an extended period without the generator operating.
- Slow average driving speeds for short periods.
- Electrical load exceeding generator output particularly with addition of aftermarket equipment.
- Defects in charging system such as high resistance, slipping drive belt, loose generator output terminal, faulty generator or voltage regulator. Refer to “GENERATOR” in this “DIAGNOSIS” section.
- Battery abuse, including failure to keep battery cable terminals clean and tight or loose battery hold down.
- Mechanical problems in electrical system such as shorted or pinched wires.

#### VISUAL INSPECTION

Check for obvious damage, such as cracked or broken case or cover, that could permit loss of electrolyte. If obvious damage is noted, replace battery. Determine cause of damage and correct as needed.

## HYDROMETER TEST

The direct method of checking the battery for state of charge is to carry out a high rate discharge test, which involves a special precise voltmeter and an expensive instrument used in the service shops, but not recommendable to the user of the vehicle.

At 20 °C of battery temperature (electrolyte temperature):

- The battery is in FULLY CHARGED STATE if the electrolyte S.G. is 1.280.
- The battery is in HALF CHARGED STATE if the S.G. is 1.220.
- The battery is in NEARLY DISCHARGED STATE if the S.G. is 1.150 and is in danger of freezing.

As the S.G. varies with the temperature, if battery temperature is not at 20°C (68°F), you have to correct your S.G. reading (taken with your hydrometer) to the value at 20°C (68°F) and apply the corrected S.G. value to the three-point guide stated value.

For the manner of correction, refer to the graph showing the relation between S.G. value and temperature at the left.

### How to use the temperature-corrected state-of-charge graph

Suppose your S.G. reading is 1.28 and the battery temperature is –5 °C (23°F). Locate the intersection of the –5 °C line and the 1.28 S.G. line.

The intersection is within the “A” zone (shaded area in the graph) and that means CHARGED STATE.

To know how much the battery is charged, draw a line parallel to the zone demarcation line and extend it to the right till it meets with the percentage scale. In the present example, the line meets at about 85% point on the percentage scale. Therefore, the battery is charged up to the 85% level.

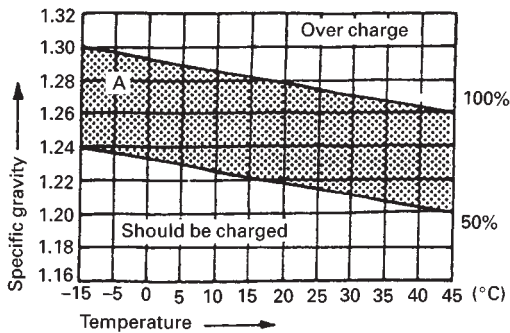

## GENERATOR

[60 A type]

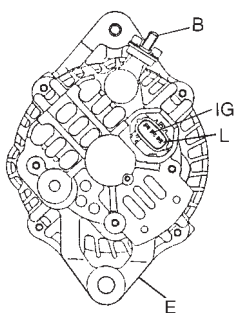

[70 A type]

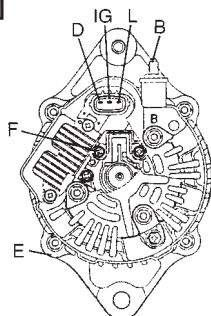

[85 A type]

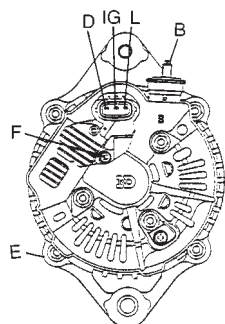

B : Generator output (Battery terminal)  
 D : Dummy terminal  
 E : Ground  
 F : Field coil terminal  
 IG : Ignition terminal  
 L : Lamp terminal

### CAUTION:

- Do not mistake polarities of IG terminal and L terminal.
- Do not create a short circuit between IG and L terminals. Always connect these terminals through a lamp.
- Do not connect any load between L and E.
- When connecting a charger or a booster battery to vehicle battery, refer to this section describing battery charging.

Trouble in charging system will show up as one or more of following conditions:

- 1) Faulty indicator lamp operation.
- 2) An undercharged battery as evidenced by slow cranking or indicator dark.
- 3) An overcharged battery as evidenced by excessive spewing of electrolyte from vents.

Noise from generator may be caused by a loose drive pulley, loose mounting bolts, worn or dirty bearings, defective diode, or defective stator.

## FAULTY INDICATOR LAMP OPERATION

PROBLEM	POSSIBLE CAUSE	CORRECTION
Charge light does not light with ignition ON and engine off	<ul style="list-style-type: none"> <li>◦ Fuse blown</li> <li>◦ Light burned out</li> <li>◦ Wiring connection loose</li> <li>◦ IC regulator faulty (60 A type only)</li> <li>◦ IC regulator or field coil faulty (70 A and 85 A types only)</li> <li>◦ Poor contact between brush and slip ring (70 A and 85 A types only)</li> </ul>	Check fuse. Replace light. Tighten loose connection. Check generator. Check generator. Repair or replace.
Charge light does not go out with engine running (battery requires frequent recharging)	<ul style="list-style-type: none"> <li>◦ Drive belt loose or worn</li> <li>◦ IC regulator or generator faulty</li> <li>◦ Wiring faulty</li> </ul>	Adjust or replace drive belt. Check charging system. Repair wiring.

### UNDERCHARGED BATTERY

This condition, as evidenced by slow cranking or indicator clear with red dot can be caused by one or more of the following conditions even though indicator lamp may be operating normal. Following procedure also applies to cars with voltmeter and ammeter.

- 1) Make sure that undercharged condition has not been caused by accessories left on for extended period of time.
- 2) Check drive belt for proper tension.
- 3) If battery defect is suspected, refer to BATTERY section.
- 4) Inspect wiring for defects. Check all connections for tightness and cleanliness, battery cable connections at battery, starting motor and ignition ground cable.
- 5) Connect voltmeter and ammeter as shown in left figure.

#### Voltmeter

Set between generator B terminal and ground.

#### Ammeter

Set between generator B terminal and battery (+) terminal.

#### NOTE:

Use fully charged battery.

- 6) Measure current and voltage.

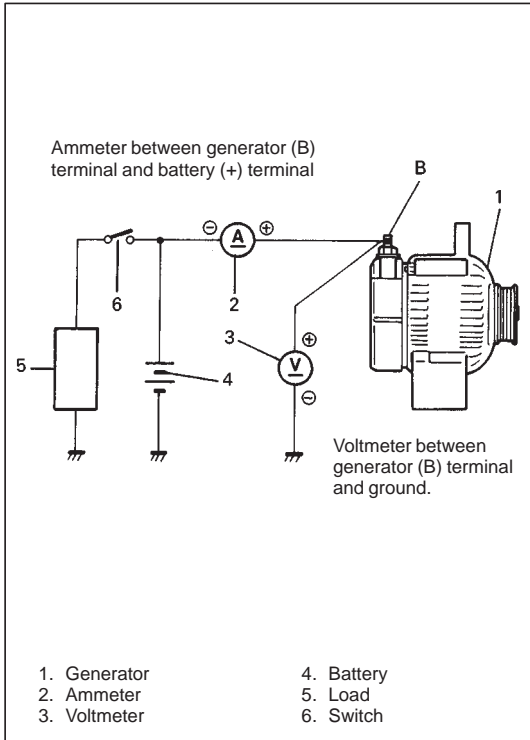

#### [60 A type]

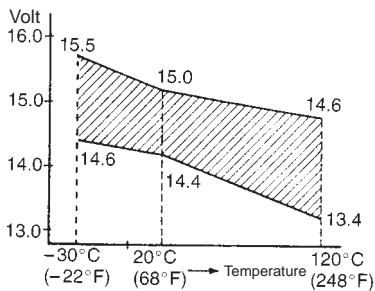

#### [70 A and 85 A types]

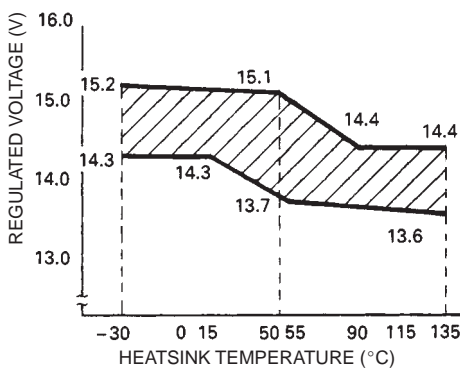

#### No-load Check

- 1) Run engine from idling up to 2,000 rpm and read meters.

#### NOTE:

Turn off switches of all accessories (wiper, heater etc.).

Standard current: 10 A maximum

Standard voltage: 14.4 – 15.0 V (at 20°C, 85°F) 60 A type  
14.1 – 15.2 V (at 20°C, 68°F) 70 A and 85 A types

#### NOTE:

Consideration should be taken that voltage will differ somewhat with regulator case temperature as shown in left figure.

**Higher Voltage**

If voltage is higher than standard value, check ground of brushes. If brushes are not grounded, replace IC regulator.

**Lower Voltage**

**[60 A type]**

If voltage is below or in standard value, increase engine speed up to 2000 – 2500 rpm soon after starting engine, and read maximum value on ammeter immediately.

If current is less than 42 A, repair or replace generator.

**[70 A and 85 A types]**

If voltage is lower than standard value, proceed to following check.

2) Ground F terminal and start engine, then measure voltage at B terminal as shown in left figure.

- Voltage is higher than standard value  
It is considered that generator itself is good but IC regulator has been damaged, replace IC regulator.
- Voltage is lower than standard value  
Generator itself has problem, check the generator.

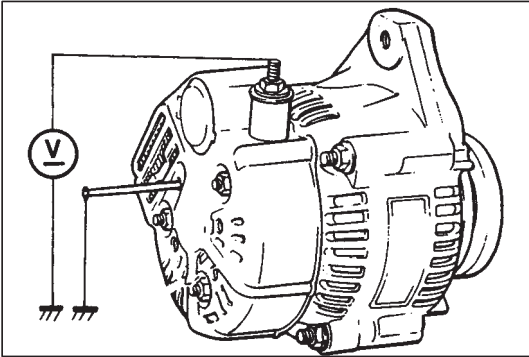

**Load Check [70 A and 85 A types only]**

- 1) Run engine at 2,000 rpm and turn on head light and heater motor.
- 2) Measure current and if it is less than 20 A (70A type) or 30 A (85 A type) repair or replace generator.

**[60 A type]**

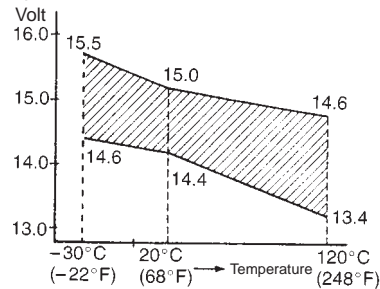

**[70 A and 85 A types]**

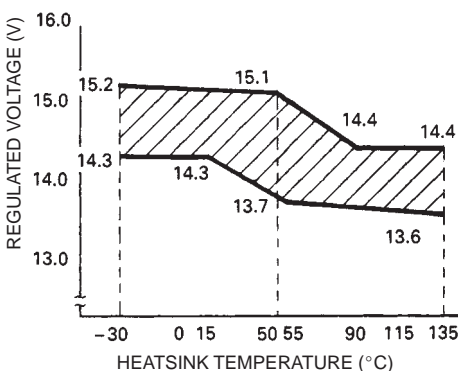

**OVERCHARGED BATTERY**

- 1) To determine battery condition, refer to BATTERY section.
- 2) If obvious overcharge condition exists as evidenced by excessive spewing of electrolyte, measure generator B terminal voltage at engine 2000 rpm.
- 3) If measured voltage is higher than upper limit value, proceed to disassembly section of generator service.
- 4) Check ground of brushes. If brushes are not grounded, replace IC regulator. Then check field coil for grounds and shorts, referring to "INSPECTION" section.

## ON-VEHICLE SERVICE

### BATTERY

#### JUMP STARTING IN CASE OF EMERGENCY WITH AUXILIARY (BOOSTER) BATTERY

**CAUTION:**

If vehicle is manual transmission model and has a catalytic converter, do not push or tow it to start. Damage to its emission system and/or to other parts may result.

Both booster and discharged battery should be treated carefully when using jumper cables. Follow procedure outlined below, being careful not to cause sparks.

**WARNING:**

- Departure from these conditions or procedure described below could result in:
  - (1) Serious personal injury (particularly to eyes) or property damage from such causes as battery explosion, battery acid, or electrical burns.
  - (2) Damage to electronic components of either vehicle.
- Remove rings, watches, and other jewelry. Wear approved eye protection.
- Be careful so that metal tools or jumper cables do not contact positive battery terminal (or metal in contact with it) and any other metal on vehicle, because a short circuit could occur.

- 1) Set parking brake and place automatic transmission in PARK (NEUTRAL on manual transmission). Turn off ignition, turn off lights and all other electrical loads.
- 2) Check electrolyte level. If it is below low level line, add distilled water.
- 3) Attach end of one jumper cable to positive terminal of booster battery and the other end of the same cable to positive terminal of discharged battery. (Use 12-volt battery only to jump start engine).
- 4) Attach one end of the remaining negative cable to negative terminal of booster battery, and the other end to a solid engine ground (such as exhaust manifold) at least 45 cm (18 in.) away from battery of vehicle being started.

**WARNING:**

Do not connect negative cable directly to negative terminal of dead battery.

- 5) Start engine of vehicle with booster battery and turn off electrical accessories. Then Start engine of the vehicle with discharged battery.
- 6) Disconnect jumper cables in the exact reverse order.

**WITH CHARGING EQUIPMENT****CAUTION:**

When jump starting engine with charging equipment, be sure equipment used is 12-volt and negative ground. Do not use 24-volt charging equipment. Using such equipment can cause serious damage to electrical system or electronic parts.

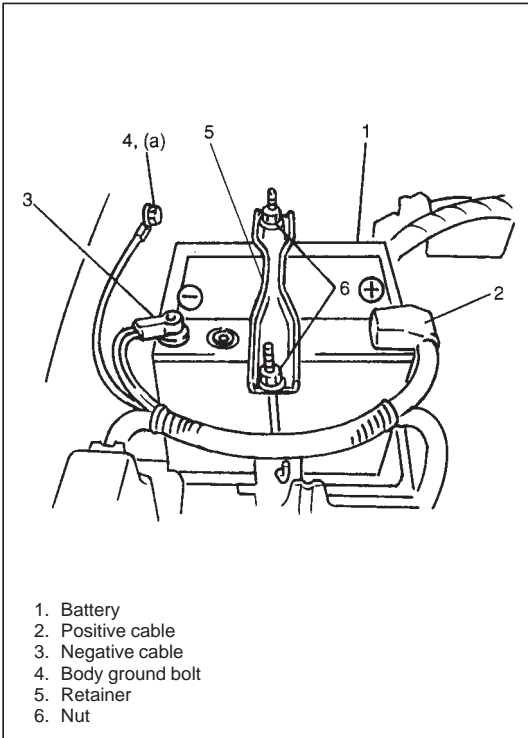
**DISMOUNTING**

- 1) Disconnect negative cable.
- 2) Disconnect positive cable.
- 3) Remove retainer.
- 4) Remove battery.

**HANDLING**

When handling battery, following safety precautions should be followed:

- Hydrogen gas is produced by battery. A flame or spark near battery may cause the gas to ignite.
- Battery fluid is highly acidic. Avoid spilling on clothing or other fabric. Any spilled electrolyte should be flushed with large quantity of water and cleaned immediately.

**REMOUNTING**

- 1) Reverse removal procedure.
- 2) Torque battery cables to specification.

**NOTE:**

Check to be sure that ground cable has enough clearance to hood panel by terminal.

**Tightening Torque**

(a): 8.0 N·m (0.8 kg-m, 6.0 lb-ft)

## GENERATOR

### GENERATOR BELT

#### [G16 and H25 engines]

Refer to "COOLING FAN BELT" in SECTION 6B "ENGINE COOLING".

#### [J20 engine]

### INSPECTION

- Inspect belt for cracks, cuts, deformation, wear and cleanliness. If any of above conditions are found replace generator belt.
- Check to make sure that tension indicators are as follows in the left figure by using mirror.
  - (a) If the tension indicator "B" is found to the left of the indicator "A", replace the generator belt.
  - (b) If new generator belt has been installed, indicator "A" should be within "a" of the left figure. If it isn't, it means that belt is not installed properly. Reinstall it properly.

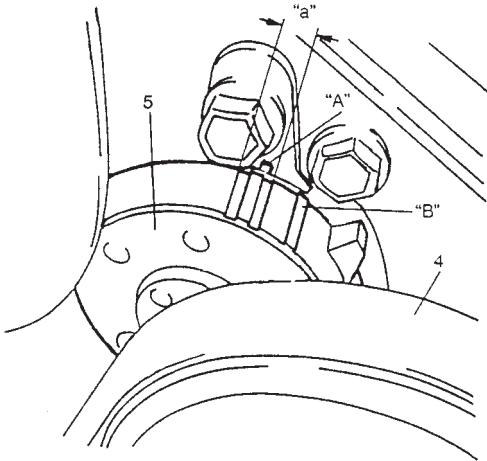
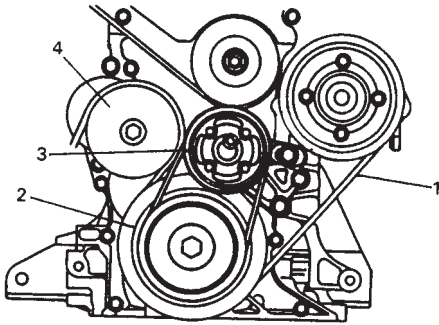

1. Generator belt
2. Crankshaft pulley
3. Radiator fan pulley
4. Tension pulley
5. Tensioner

### REMOVAL

#### WARNING:

**Disconnect negative cable at battery before removing and installing generator belt.**

- 1) Loosen tensioner by turning the tensioner pulley clock wise.
- 2) While holding the tensioner and belt loose, remove generator belt.

### INSTALLATION

- 1) Loosen tensioner by turning the tensioner pulley clockwise.
- 2) While holding the tensioner, install generator belt.

#### NOTE:

- **Make sure that the belt fits each pulley's groove properly.**
- **After installing generator belt, perform checks described above and make sure that tension indicator is within standard range.**

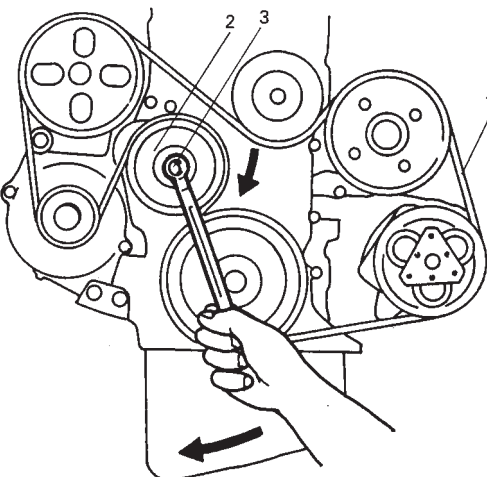

1. Generator belt
2. Tensioner
3. Tensioner bolt

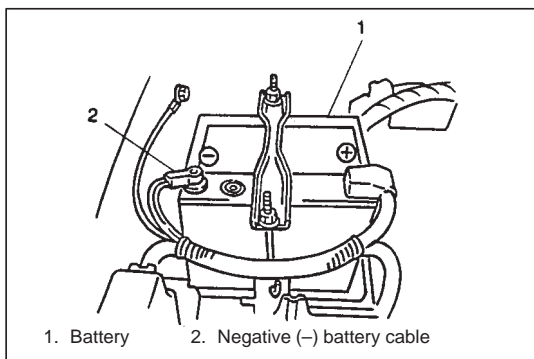

1. Battery 2. Negative (-) battery cable

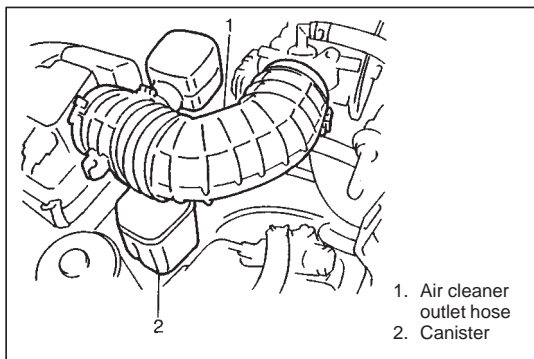

1. Air cleaner outlet hose  
2. Canister

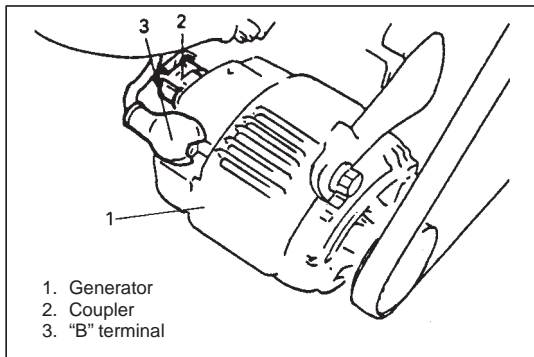

1. Generator  
2. Coupler  
3. "B" terminal

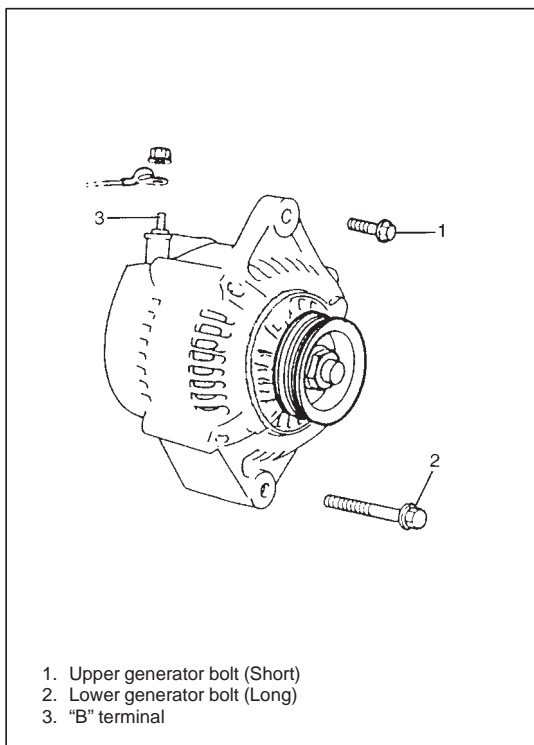

1. Upper generator bolt (Short)  
2. Lower generator bolt (Long)  
3. "B" terminal

## UNIT REPAIR OVERHAUL

### GENERATOR

#### DISMOUNTING

1) Disconnect negative (-) cable at battery.

2) Remove air cleaner outlet hose.  
3) Remove canister from its bracket.

4) Disconnect "B" terminal wire and coupler from generator.

5) Remove generator belt. Refer to SECTION 6B "ENGINE COOLING" (G16 and H25 engines) or "GENERATOR BELT" (J20 engine) in this section.  
6) Remove generator.

## REMOUNTING

- 1) Mount generator on the generator bracket.
- 2) Tighten generator bolts.

### Tightening Torque

**(a): 23 N·m (2.3 kg-m, 16.5 lb-ft)**

- 3) Install generator (cooling fan) belt. Refer to SECTION 6B "ENGINE COOLING" (G16 and H25 engines) or "GENERATOR BELT" (J20 engine) in this section.
- 4) Install cooling fan belt (J20 engine only). Refer to SECTION 6B "ENGINE COOLING".
- 5) Connect "B" terminal wire and coupler to generator.

### Tightening Torque

**(b): 8.0 N·m (0.8 kg-m, 6.0 lb-ft)**

- 6) Install canister.
- 7) Install air cleaner outlet hose.
- 8) Connect negative (-) cable at battery.

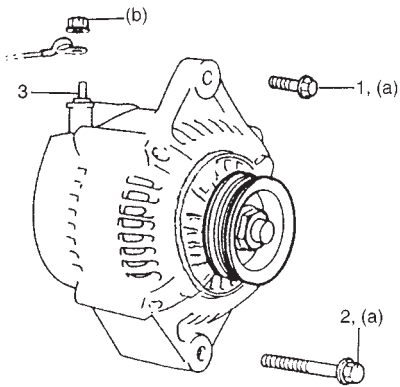

1. Upper generator bolt (Short)
2. Lower generator bolt (Long)
3. "B" terminal

## DISASSEMBLY [60 A type]

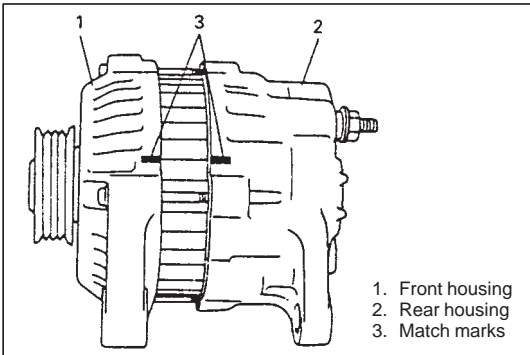
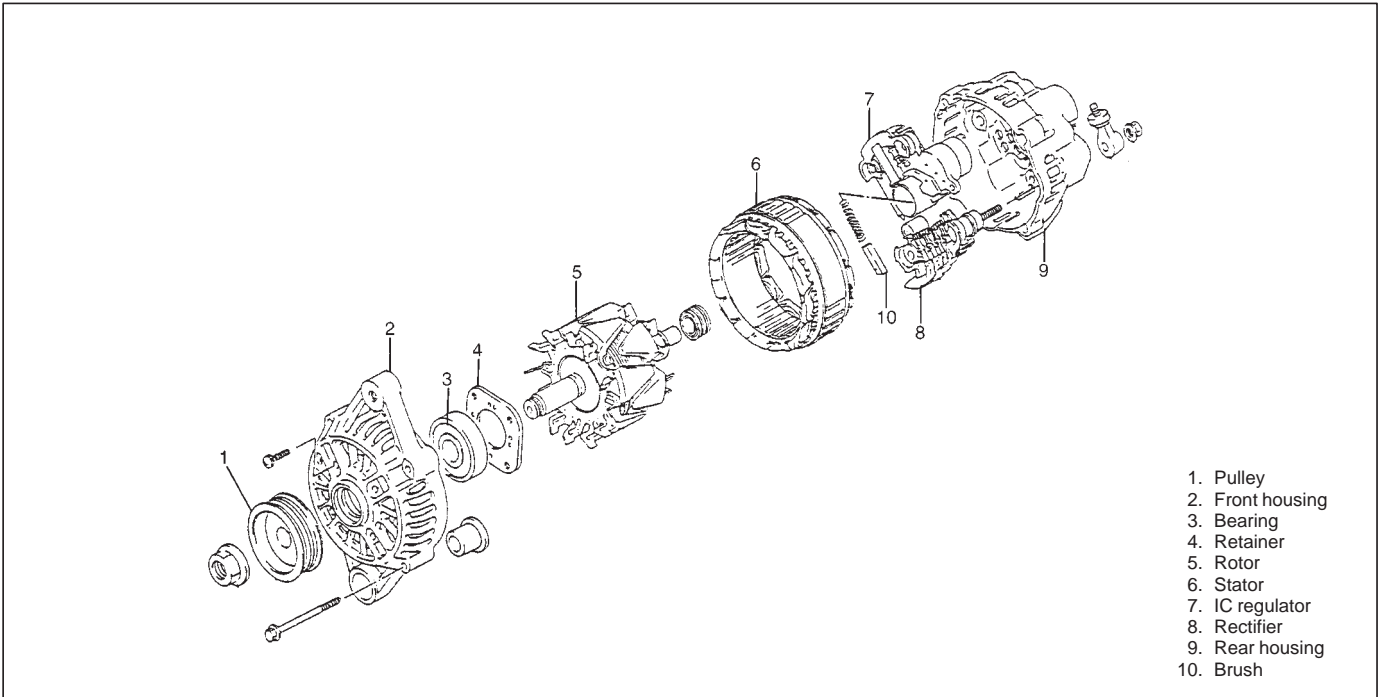

1) For easier reinstallation, provide match marks on both front and rear housings as shown in left figure before separating them.

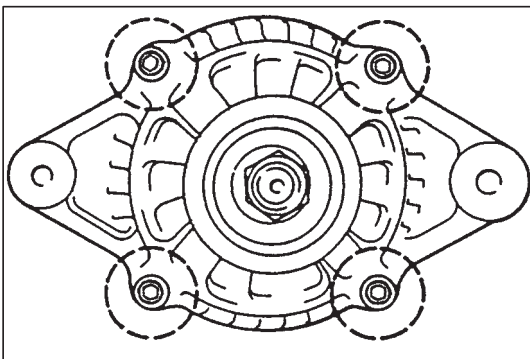

2) Remove housing bolts from generator.

- 3) With lever inserted between stator core and front housing, separate generator into front and rear sides.

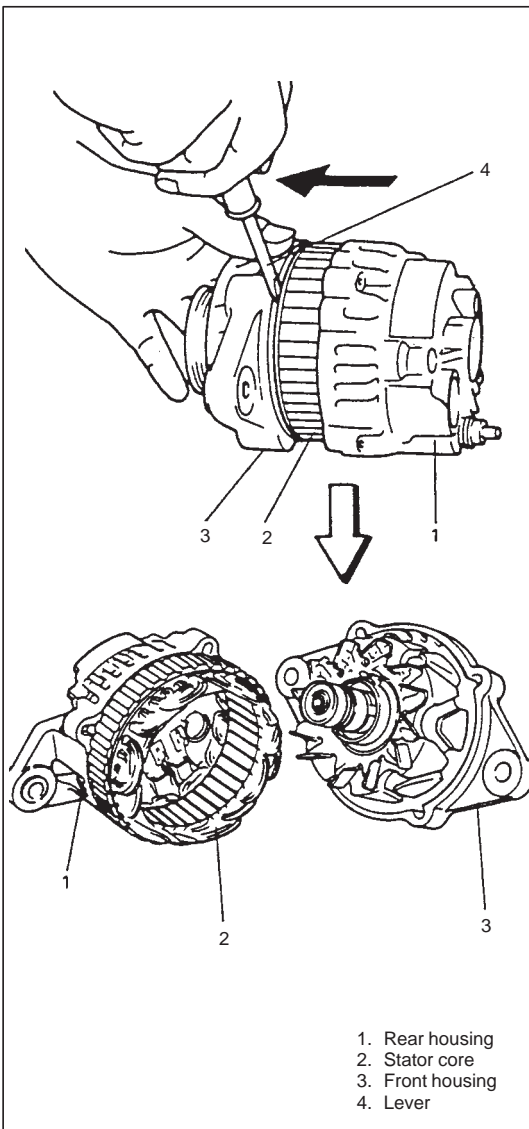

- 4) Loosen pulley nut by using vise and take off pulley.

**NOTE:**

- When using vise, put clean cloth between rotor and vise so as not to cause damage to rotor.
- Be sure to hold the location A. Do not hold the location B as it does not have enough structural strength.

- 5) Remove rotor from front housing.

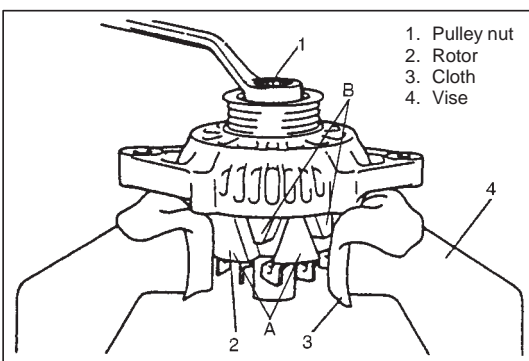

- 6) When removing front bearing, remove bearing retainer screws and retainer.

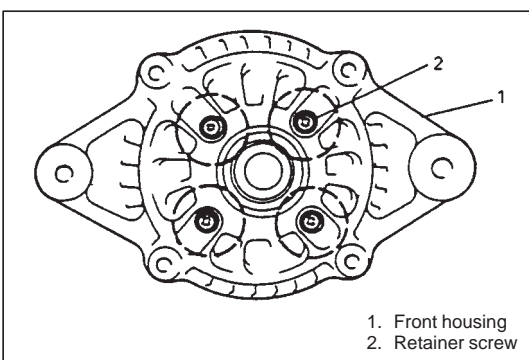

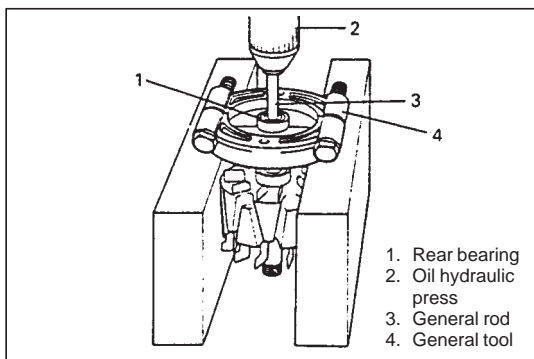

7) When removing rear bearing, use oil hydraulic press.

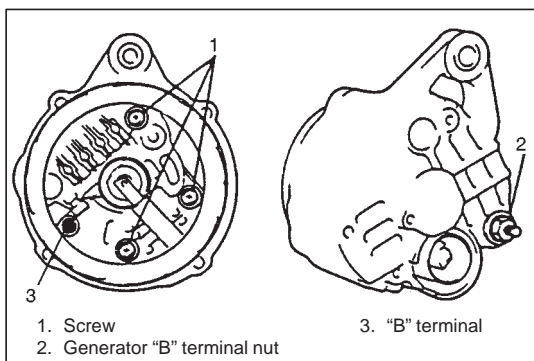

8) Remove three screws and generator "B" terminal nut.

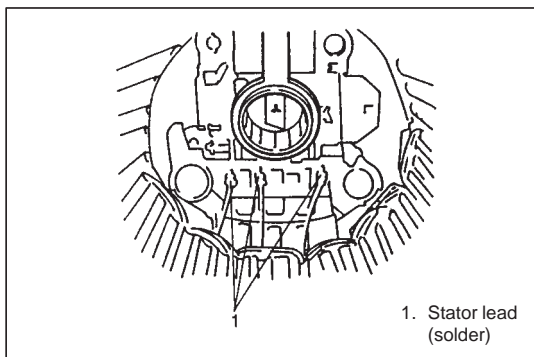

9) Unsolder stator leads and remove stator from rear housing and regulator assembly.

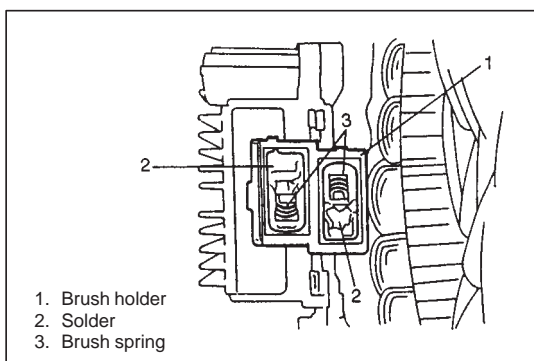

10) To remove brush, remove holder cover from brush holder and then disconnect brush wire from regulator terminal by using soldering iron.

DISASSEMBLY [70 A and 85 A types]

[70A type]

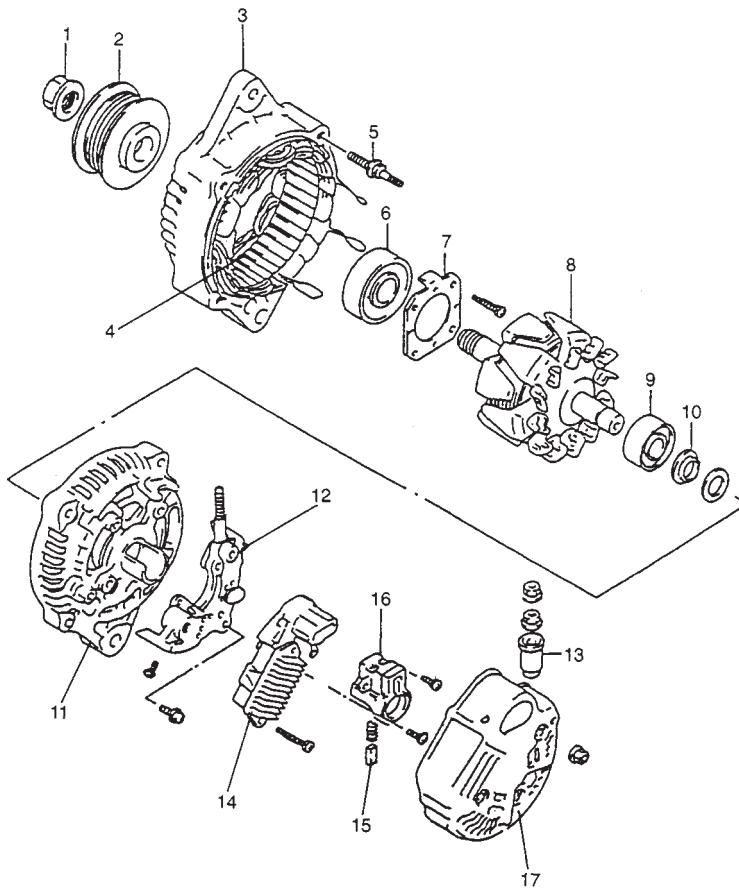

1. Pulley nut
2. Pulley
3. Drive end frame
4. Stator
5. Stud bolt
6. Drive end bearing
7. Bearing retainer
8. Rotor
9. End housing bearing
10. Bearing cover
11. Rear end frame
12. Rectifier
13. Insulator
14. Regulator
15. Brush
16. Brush holder
17. Rear end cover

[85 A type]

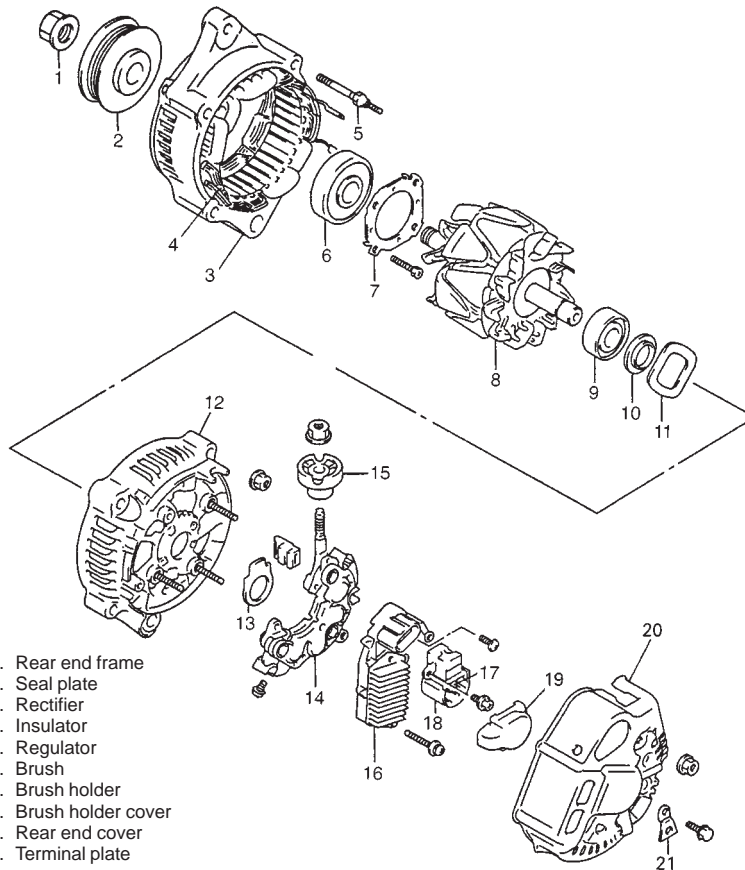

- |                        |                        |
|------------------------|------------------------|
| 1. Pulley nut          | 12. Rear end frame     |
| 2. Pulley              | 13. Seal plate         |
| 3. Drive end frame     | 14. Rectifier          |
| 4. Stator              | 15. Insulator          |
| 5. Stud bolt           | 16. Regulator          |
| 6. Drive end bearing   | 17. Brush              |
| 7. Bearing retainer    | 18. Brush holder       |
| 8. Rotor               | 19. Brush holder cover |
| 9. End housing bearing | 20. Rear end cover     |
| 10. Bearing cover      | 21. Terminal plate     |
| 11. Wave washer        |                        |

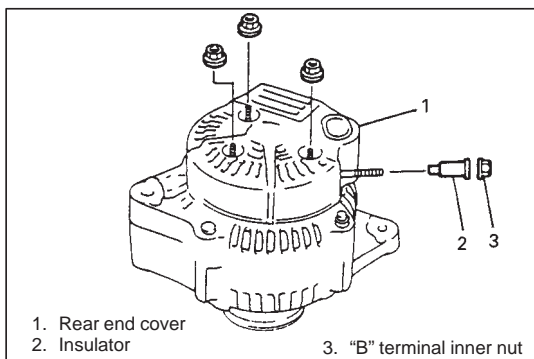

- 1) Remove "B" terminal inner nut and insulator.
- 2) Remove rear end cover.

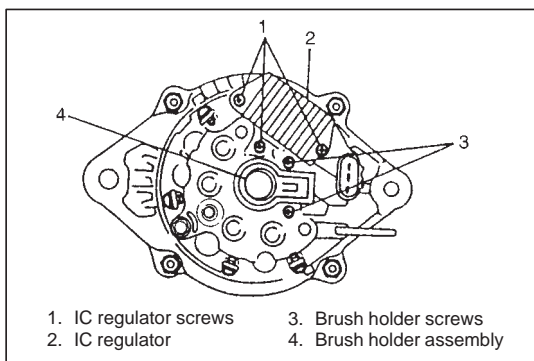

- 3) Remove 2 screws and pull out brush holder assembly.
- 4) Remove 3 screws and IC regulator.
- 5) Remove brush holder cover from brush holder.

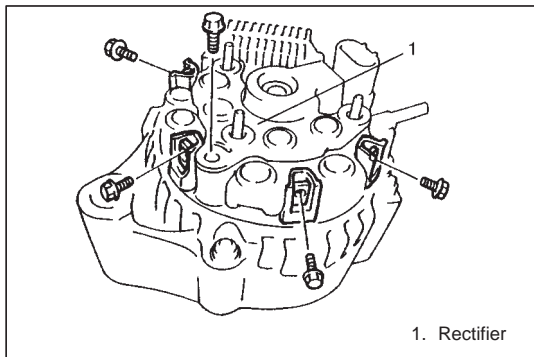

- 6) Remove 4 screws, 1 bolt and rectifier.

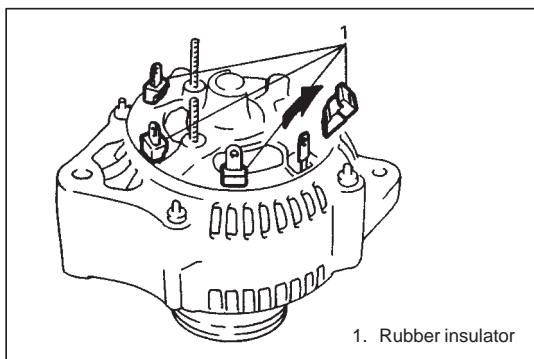

- 7) Remove 4 rubber insulators (85 A type only).

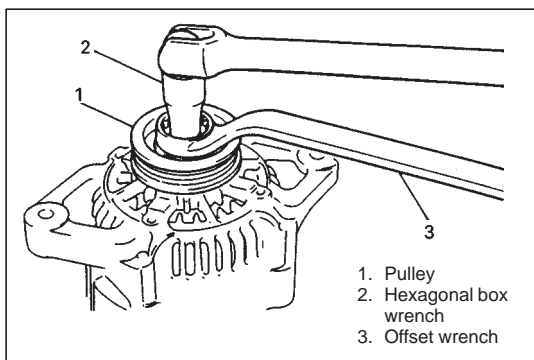

- 8) Hold shaft by using hexagonal box wrench and remove pulley nut, and then pull out pulley.

**CAUTION:**

- To hold shaft, use hexagonal box. Duodecimal box may cause slipping and consequential shaft or tool damage.
- Do not attempt to hold pulley by using vise or pipe wrench so as not to distort it.

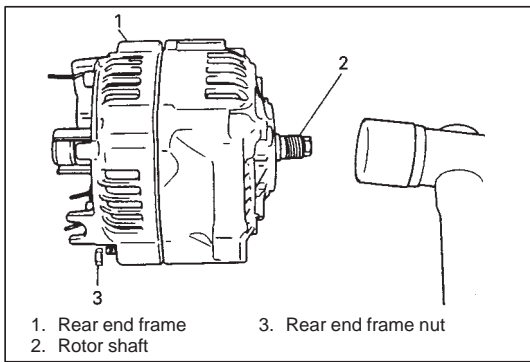

- 9) Remove 4 rear end frame nuts.
- 10) Drive out rear end frame with rotor tapping shaft lightly by using plastic hammer.
- 11) Separate rear end frame from rotor evenly by using plastic hammer.

**CAUTION:**

**Do not hit shaft at slip ring side, when separating rotor and rear end frame.**

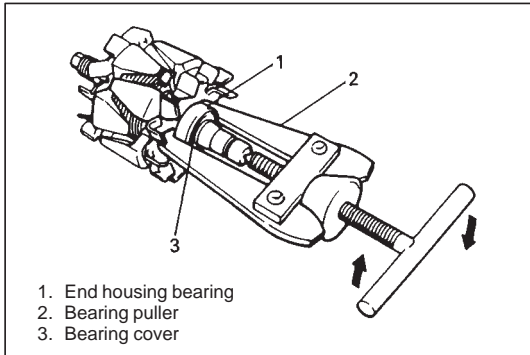

- 12) If required, use bearing puller to remove end housing bearing and bearing cover.

**CAUTION:**

**Care must be exercised so as not to distort cooling fan blade while applying puller.**

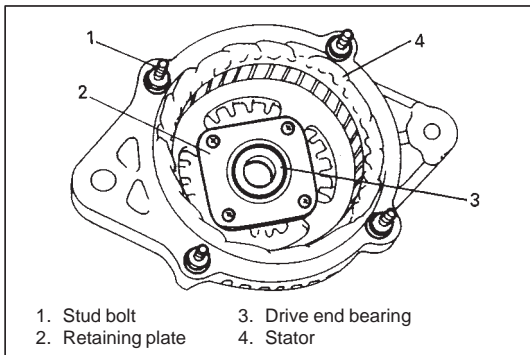

- 13) If required, remove 4 screws, retainer plate and then drive out drive end bearing.

- 14) If required, remove stud bolts and then pull out stator.

**NOTE:**

**Heating drive end frame may facilitate removal of stator.**

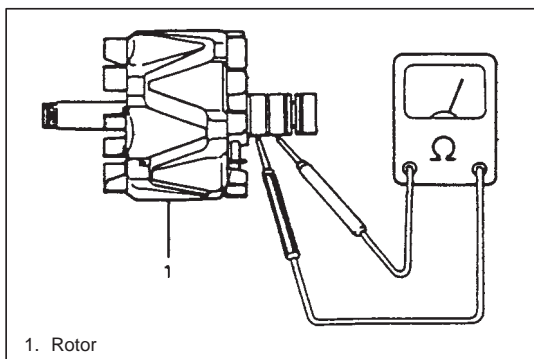

## INSPECTION [60 A type]

### Rotor

- 1) Using ohmmeter, check for continuity between slip rings of rotor. If there is no continuity, replace rotor.

**Standard resistance: 2.5 – 2.9 Ω**

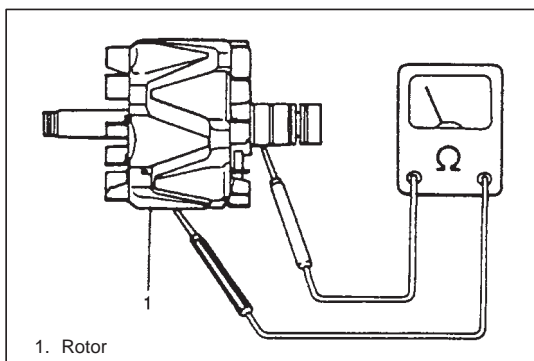

- 2) Using ohmmeter, check that there is no continuity between slip ring and rotor core. If there is continuity, replace rotor.
- 3) Check slip rings for roughness or scoring. If rough or scored, replace rotor.

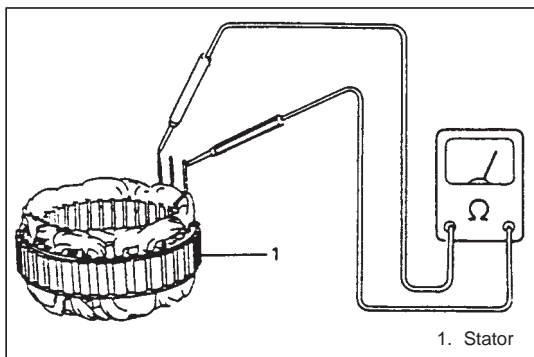

### Stator

- 1) Using ohmmeter, check all leads for continuity. If there is no continuity, replace stator.

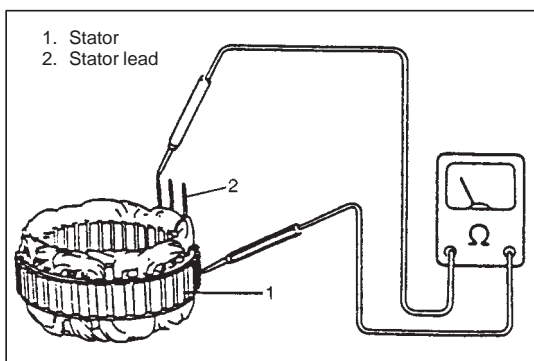

- 2) Using ohmmeter, check that there is no continuity between coil leads and stator core. If there is continuity, replace stator.

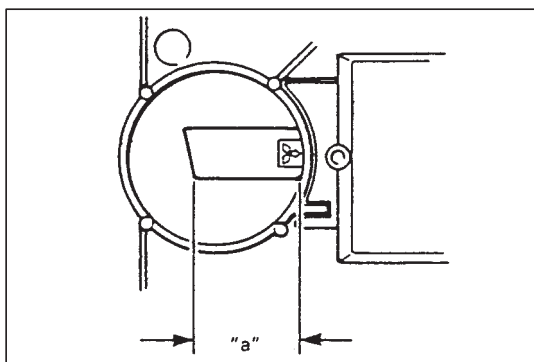

### Brush and brush holder

Check each brush for wear by measuring its length. If brush is found worn down to service limit, replace brush.

#### Brush length "a"

**Standard: 16 mm (0.63 in.)**

**Service limit: 2 mm (0.08 in.)**

**Rectifier**

- 1) Using ohmmeter, check continuity between each of upper and lower rectifier bodies and each diode lead. Check both directions by reversing probes of ohmmeter and there should be only one-way continuity in each case. If check result is not satisfactory, replace rectifier.
- 2) In the same manner as described in above step 1), check that there is only one-way continuity between both leads of diode trio.

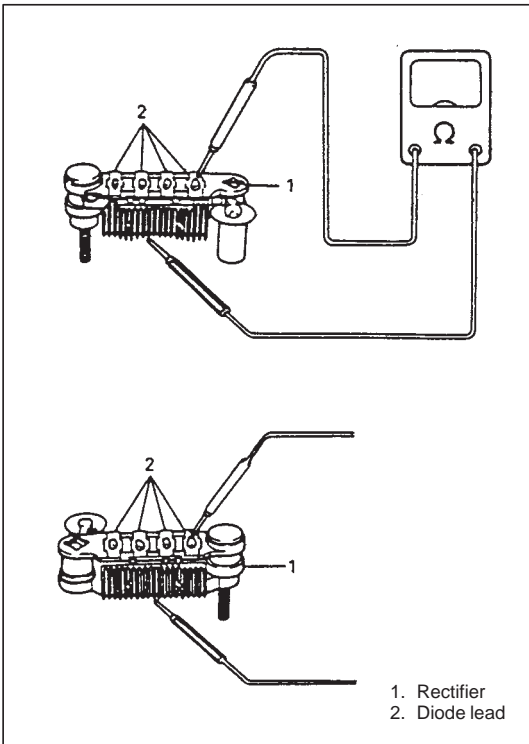
**Condenser**

Check condenser capacity.

**Condenser capacity: 0.5  $\mu$ F**

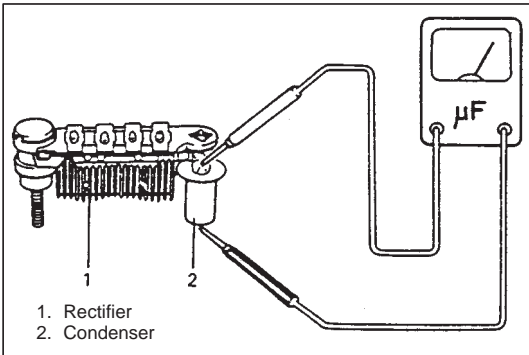

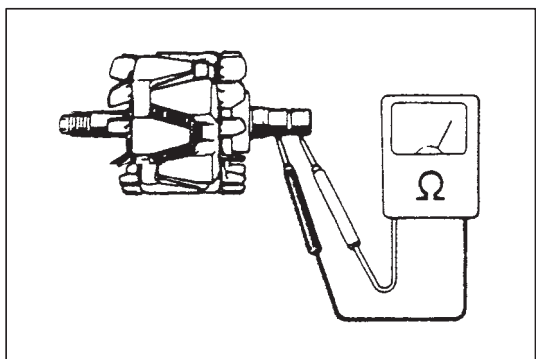

### INSPECTION [70 A and 85 A types]

#### Rotor

- Using ohmmeter, check for continuity between slip rings of rotor. If there is no continuity, replace rotor.

**Standard resistance: About 2.9 Ω**

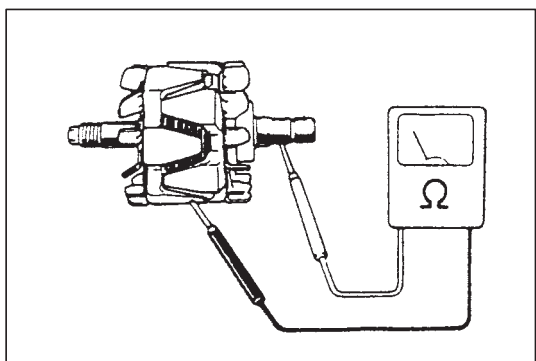

- Using ohmmeter, check that there is no continuity between slip ring and rotor. If there is continuity, replace rotor.

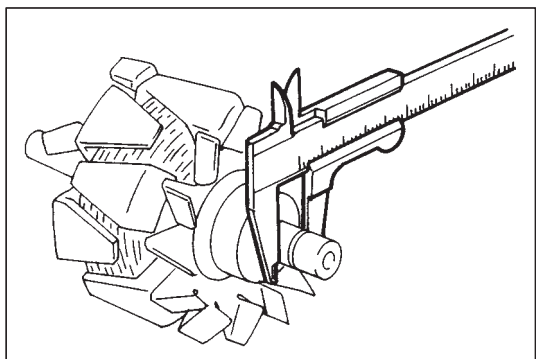

- Check slip rings for roughness or scoring. If rough or scored, replace rotor.

Using a vernier caliper, measure the slip ring diameter.

**Standard diameter: 14.2 – 14.4 mm (0.557 – 0.567 in.)**

**Minimum diameter: 12.8 mm (0.504 in.)**

If the diameter is less than minimum, replace the rotor.

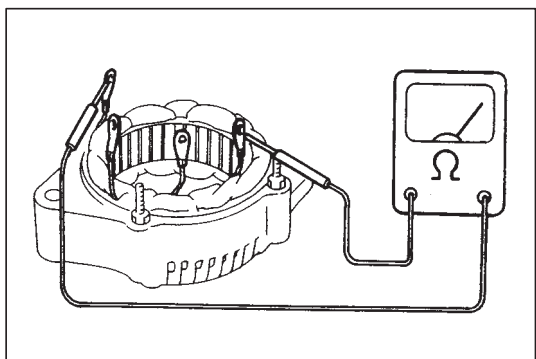

#### Stator

- Using ohmmeter, check all leads for continuity. If there is no continuity, replace stator.

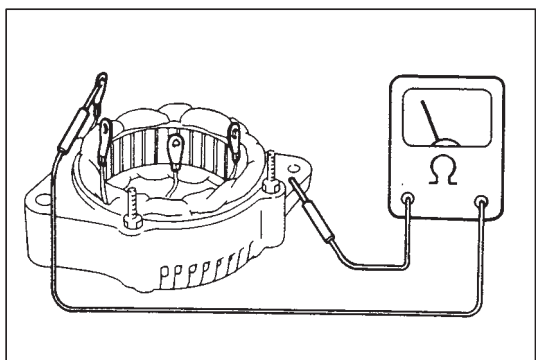

- Using ohmmeter, check that there is no continuity between coil leads and stator core. If there is continuity, replace stator.

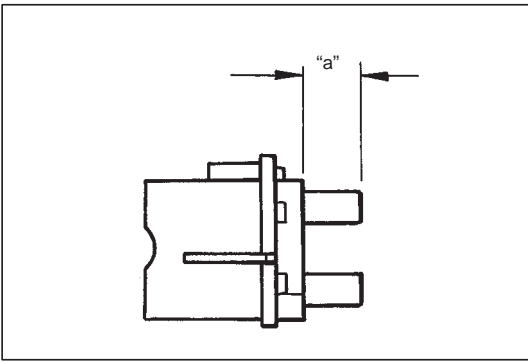

### Brush and brush holder

Check each brush for wear by measuring its length as shown. If brush is found worn down to service limit, replace brush. Refer to "Replace Brush" in this section.

#### Exposed brush length "a"

**Standard: 10.5 mm (0.413 in.)**

**Limit : 4.5 mm (0.351 in.)**

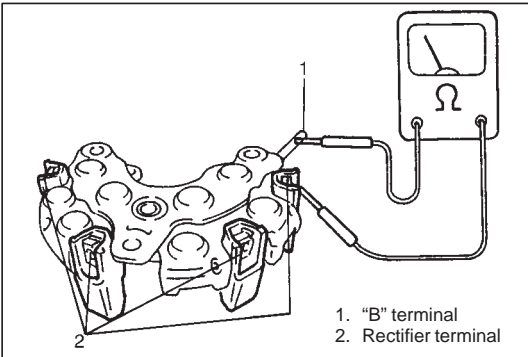

### Rectifier

#### ◦ Positive Rectifier

- 1) Using an ohmmeter, connect one tester probe to the "B" terminal and the other to each rectifier terminal.
- 2) Reverse the polarity of the tester probes and repeat step 1).
- 3) Check that one shows continuity and the other shows no continuity.

If there is continuity, replace the rectifier.

#### ◦ Negative Rectifier

- 1) Using an ohmmeter, connect one tester probe to each negative terminal and the other to each rectifier terminal.
- 2) Reverse the polarity of the tester probes and repeat step 1).
- 3) Check that one shows continuity and the other shows no continuity.

If there is continuity, replace the rectifier.

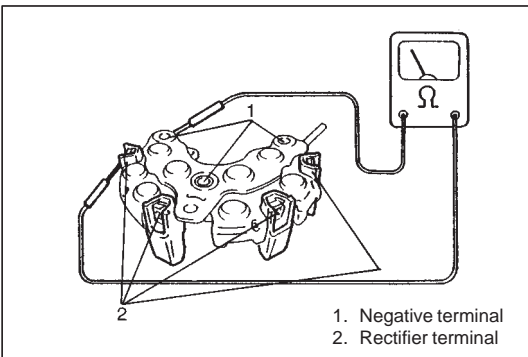

### Bearing

- Check that drive and bearing is not rough or worn.

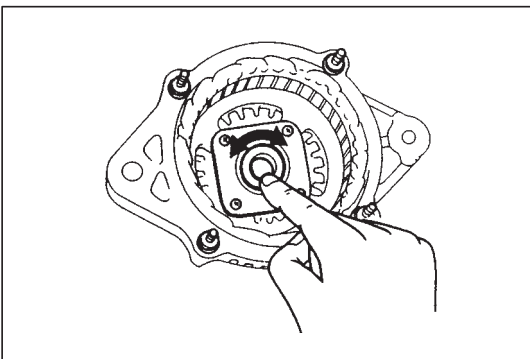

- Check that end housing bearing is not rough or worn.

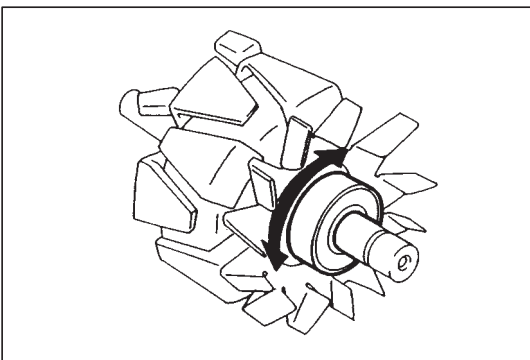

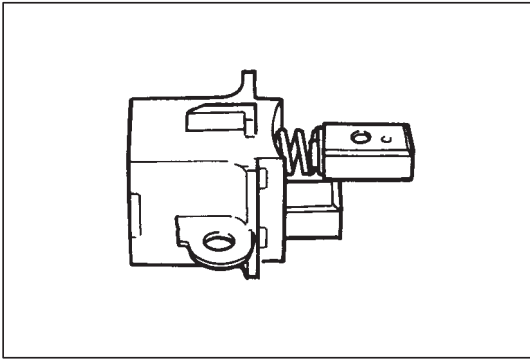

## REPLACE BRUSH

### [60 A type]

Refer to "DISASSEMBLY" and "REASSEMBLY" of 60 A type.

### [70 A and 85 A types]

- 1) Remove rear end cover and then brush holder.
- 2) Unsolder and remove the brush and spring.
- 3) Run the wire of a new brush through the spring and the hole in the brush holder, and insert the spring and brush into the brush holder.
- 4) Solder the brush wire to the brush holder at specified exposed length.

**Exposed length "a": 10.5 mm (0.413 in.)**

- 5) Check that the brush moves smoothly in the brush holder.
- 6) Cut off the excess wire.
- 7) Apply insulation paint to the soldered area.

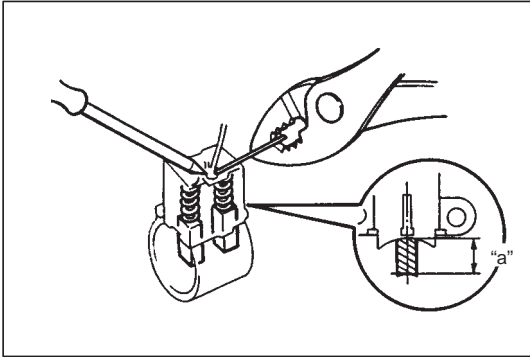

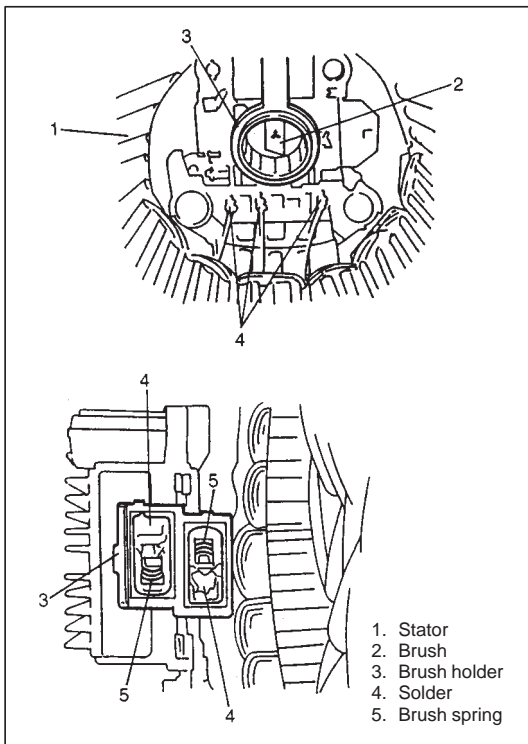

## REASSEMBLY [60 A type]

Assemble in reverse order of DISASSEMBLY, noting the following.

- 1) Be sure to install brushes in the proper direction and solder brush wires and stator leads.

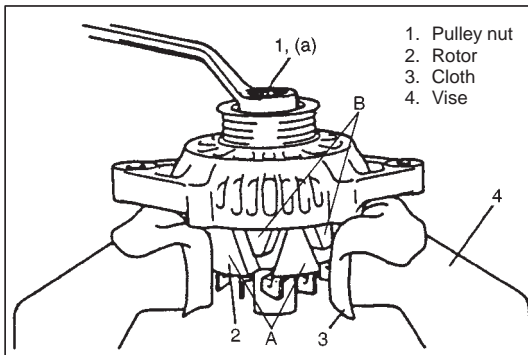

- 2) Tighten generator pulley nut to specified torque.

### Tightening Torque

(a): 118 N·m (11.8 kg·m, 85.5 lb·ft)

#### NOTE:

- When using vise, put clean cloth between rotor and vise so as not to cause damage to rotor.
- Be sure to hold the location A. Do not hold the location B as it does not have enough structural strength.

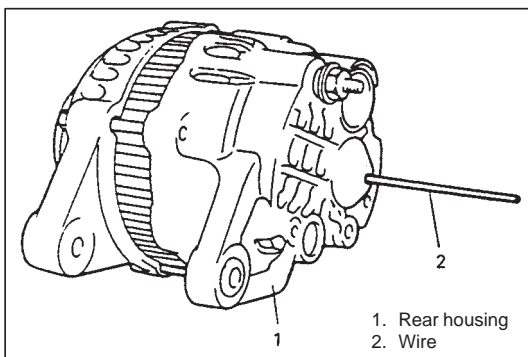

- 3) Push brushes into brush holder, then support brushes by inserting appropriate wire from hole of rear housing.

#### NOTE:

- After installing rotor, remove wire.
- Check to make sure that match marks on front and rear housing are aligned.
- Do not apply grease to rear (rotor) bearing. Remove oil completely if found in bearing box of rear housing.

- 4) After assembling generator, make sure that rotor turns smoothly.

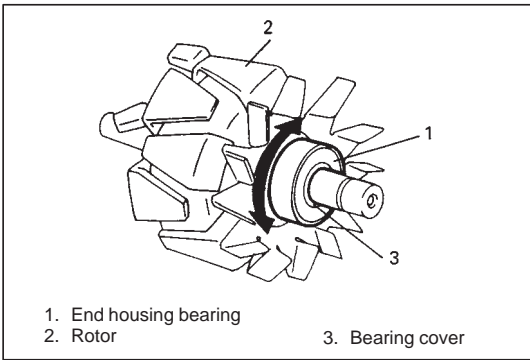

**REASSEMBLY [70 A and 85 A types]**

- 1) If end housing bearing is removed, install it.
- 2) Check end housing bearing turns smoothly.

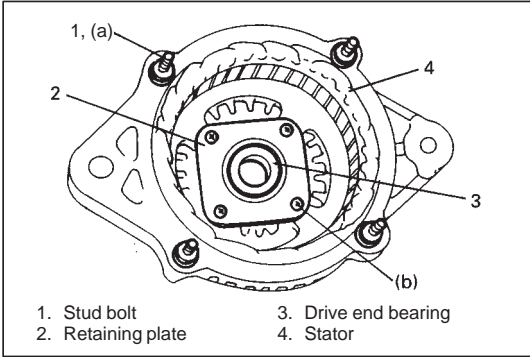

- 3) If stator is removed, install stator and tighten stud bolts.
- 4) If drive end bearing is removed, install it.
- 5) Check drive end bearing turns smoothly.

**Tightening Torque**

- (a): 8.8 N·m (0.88 kg-m, 6.5 lb-ft)
- (b): 2.6 N·m (0.26 kg-m, 2.0 lb-ft)

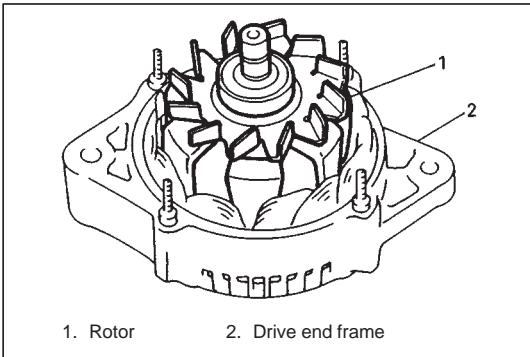

- 6) Place drive end frame on pulley, and then install rotor to drive end frame.

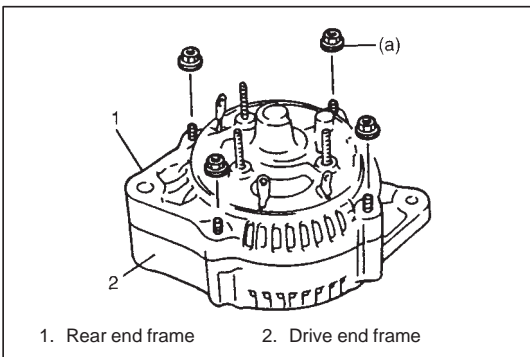

- 7) Install rear end frame to drive end frame.
- 8) Tighten 4 nuts to specified torque.

**Tightening Torque**

- (a): 4.5 N·m (0.45 kg-m, 3.5 lb-ft)

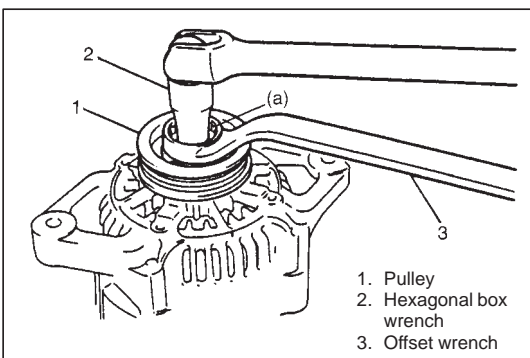

- 9) Install pulley and tighten pulley nut with holding shaft by using hexagonal box wrench to specified torque.

**Tightening Torque**

- (a): 111 N·m (11.1 kg-m, 80.5 lb-ft)

10) Install 4 rubber insulators.

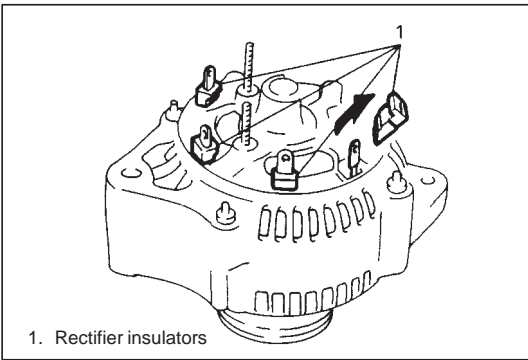

11) Install rectifier.

**CAUTION:**  
When installing rectifier, check to confirm that stator leads have enough clearance with cooling fan blades.

**Tightening Torque**

(a): 2.0 N·m (0.2 kg-m, 1.5 lb-ft)

(b): 3.9 N·m (0.39 kg-m, 3.0 lb-ft)

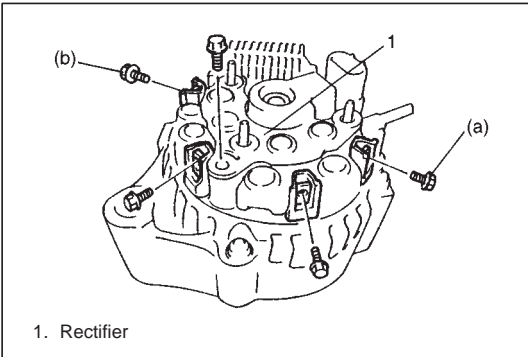

12) Install brush holder cover to brush holder.

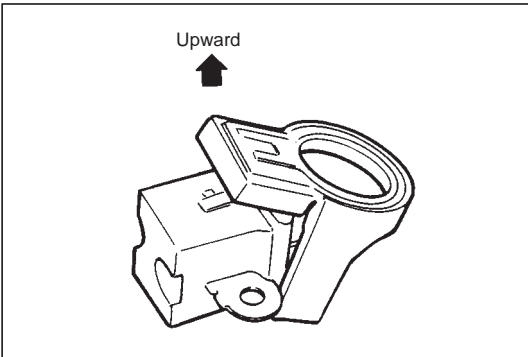

13) Place the IC regulator together with the brush holder horizontally on the rear end frame.

14) Install the 5 screws until there is a clearance of approx. 1 mm (0.04 in.) between the brush holder and connector.

**Tightening Torque**

(a): 2.0 N·m (0.2 kg-m, 1.5 lb-ft)

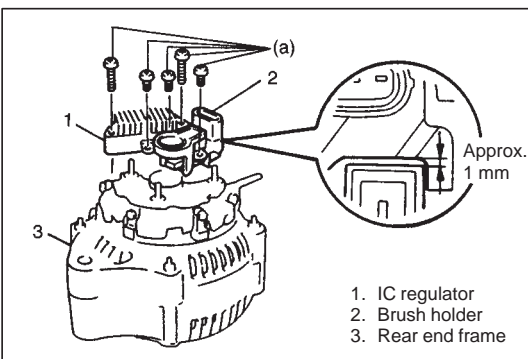

15) Install rear end cover and terminal plate.

**Tightening Torque**

(a): 4.5 N·m (0.45 kg-m, 3.5 lb-ft)

(b): 3.8 N·m (0.38 kg-m, 3.0 lb-ft) (85 A type only)

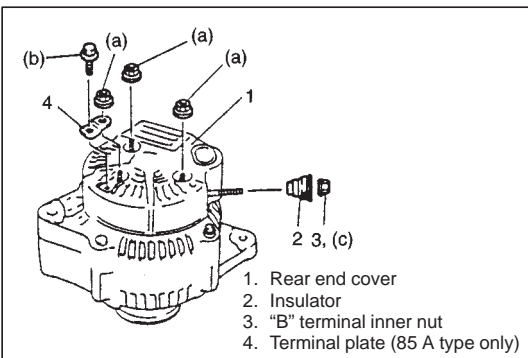

16) Install insulator and tighten "B" terminal inner nut to specified torque.

**Tightening Torque**

(c): 4.2 N·m (0.42 kg-m, 3.0 lb-ft)

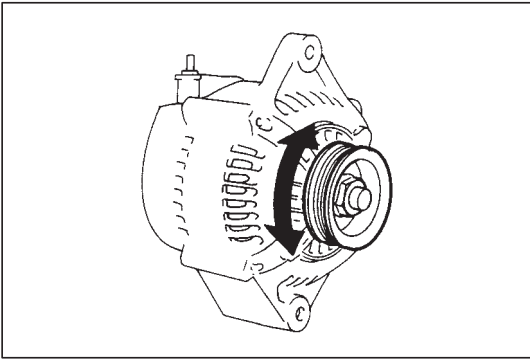

17) Make sure that rotor turns smoothly.

## SPECIFICATIONS

### BATTERY

**NOTE:**

The battery used in each vehicle is one of the following four types, depending on specification.

Battery type	38B20L	55B24L (S)	55D23L	75D23L
Rated capacity AH/5HR, 12 Volts	28	36	48	54
Electrolyte L (US/Imp. pt)	2.8 (5.92/4.93)	3.1 (6.55/5.46)	3.9 (8.24/6.86)	3.9 (8.24/6.86)
Electrolyte S.G.	1.28 when fully charged at 20°C (68°F)			

### GENERATOR

**NOTE:**

The generator used in each vehicle is one of the following three types, depending on specification.

Type	60 A type	70 A type	85 A type
Rated voltage	12 V		
Nominal output	60 A	70 A	85 A
Permissible max. speed	18000 r/min.		
No-load speed	1300 r/min (rpm)	1250 r/min (rpm)	950 r/min (rpm)
Setting voltage	14.4 to 15.0 V	13.6 to 14.4 V	
Permissible ambient temperature	-30 to 90°C (-22 to 194°F)		
Polarity	Negative ground		
Rotation	Clockwise viewed from pulley side		

## TIGHTENING TORQUE SPECIFICATIONS

Fastening	Tightening torque		
	N·m	kg-m	lb-ft
° Body ground bolt	8	0.8	6.0
° Generator mounting bolts and nut	23	2.3	16.5
° "B" terminal inner nut	4.2	0.42	3.0
° "B" terminal outer nut	8	0.8	6.0
° Pulley nut	60 A type	118	11.8
	70 A and 85 A types	111	11.1
° Rear end frame nuts	4.5	0.45	3.5
° Rear end cover nuts			
° Rectifier "B" bolt	3.9	0.39	3.0
° Stator stud bolts	8.8	0.88	6.5
° Drive end bearing plate screws	2.6	0.26	2.0
° Rectifier screws	2.0	0.20	1.5
° Regulator and brush holder screws			
° Terminal plate bolt	3.8	0.38	3.0

## SECTION 6K

# EXHAUST SYSTEM

**CAUTION:**

Be sure to use **UNLEADED FUEL** for the catalytic converter equipped vehicle. Use of **LEADED FUEL** will affect performance of the catalytic converter adversely to a great extent.

## CONTENTS

<b>GENERAL DESCRIPTION</b> .....	6K-1
<b>MAINTENANCE</b> .....	6K-3
<b>ON-VEHICLE SERVICE</b> .....	6K-4

## GENERAL DESCRIPTION

The exhaust system of the vehicle consists of the exhaust manifold, exhaust No.1 pipe (with Warm Up Three-Way Catalytic Converter, WU-TWC, if equipped), exhaust No.2 pipe (with Three-Way Catalytic Converter, TWC), muffler, seals, gasket, etc. The three way catalytic converter is an emission control device added to the exhaust system to lower the level of Hydrocarbon (HC), Carbon Monoxide (CO) and Oxides of Nitrogen (NOx) pollutants in the exhaust gas.

COMPONENTS

NOTE:

Tighten bolts and nuts ((a), (b), (c)) to specified torque, referring to "MUFFLER" in this section.

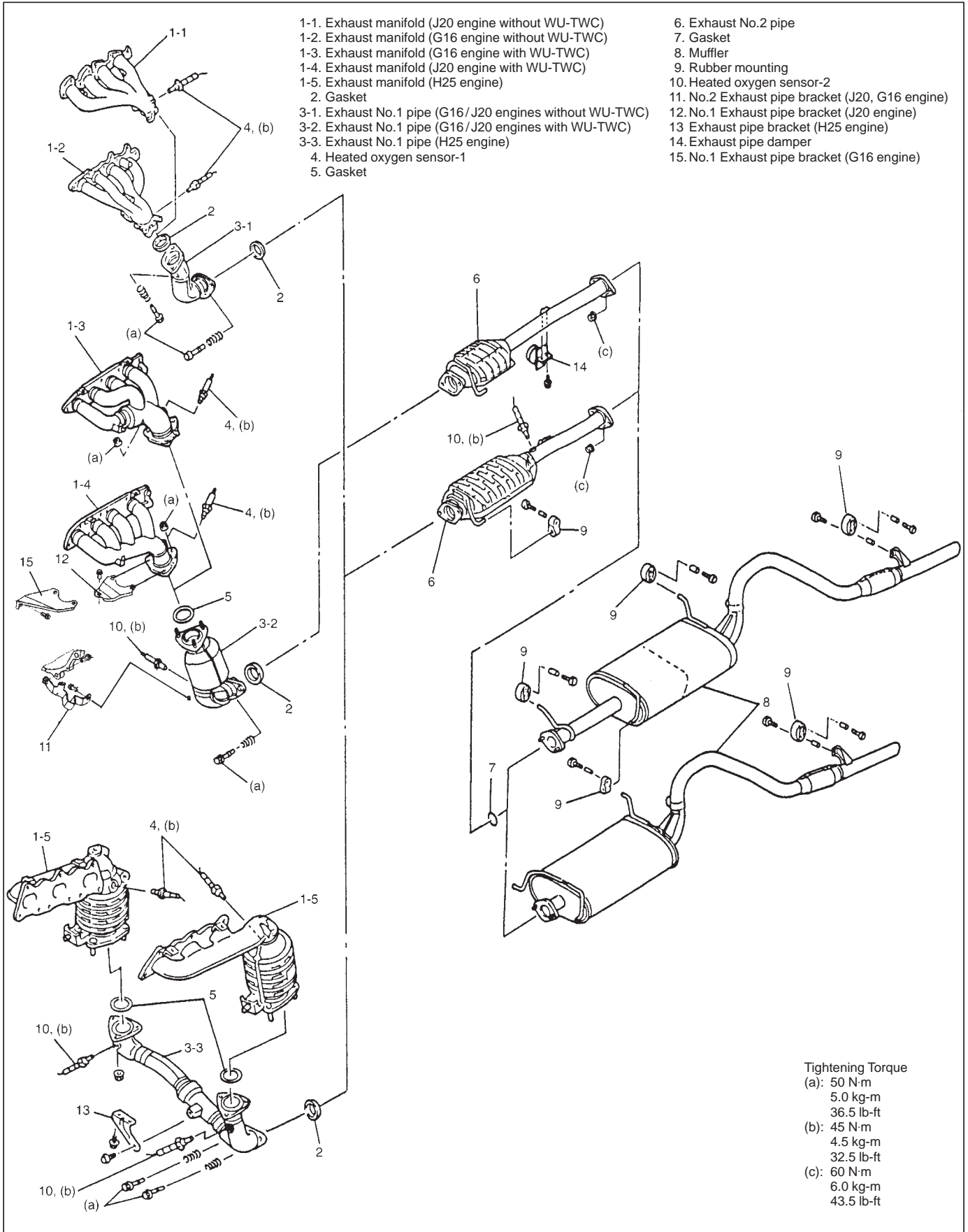

## MAINTENANCE

### WARNING:

To avoid the danger of being burned, do not touch the exhaust system when the system is hot. Any service on the exhaust system should be performed when the system is cool.

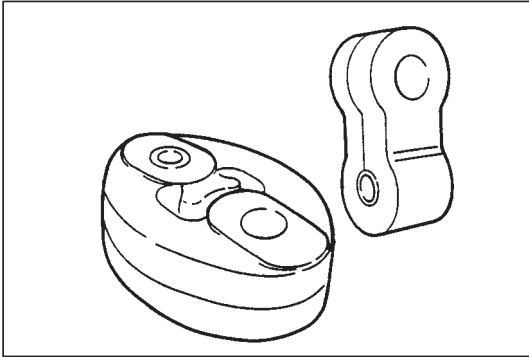

At every interval of periodic maintenance service, and when vehicle is raised for other service, check exhaust system as follows:

- Check rubber mountings for damage, deterioration, and out of position.

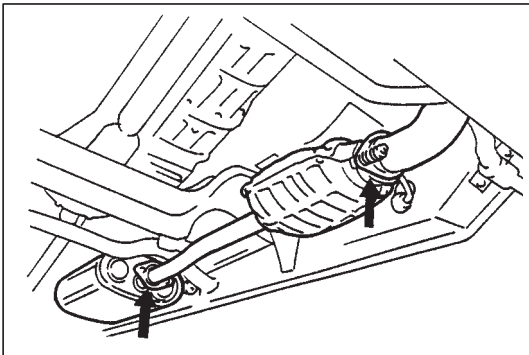

- Check exhaust system for leakage, loose connection, dent and damage.  
If bolts or nuts are loosened, tighten them to specified torque. Refer to "MUFFLER" in this section for torque data.
- Check nearby body areas damaged, missing, or mispositioned part, open seam, hole connection or any other defect which could permit exhaust fumes to seep into vehicle.
- Make sure that exhaust system components have enough clearance from underbody to avoid overheating and possible damage to passenger compartment carpet.
- Any defect should be fixed at once.

## ON-VEHICLE SERVICE

**WARNING:**

To avoid the danger of being burned, do not touch the exhaust system when the system is hot. Any service on the exhaust system should be performed when the system is cool.

**EXHAUST MANIFOLD**

Refer to Section 6A1, 6A2 or 6A4 for removal and installation procedures. Before installation, check gasket and seal for deterioration or damage. Replace them as necessary.

**MUFFLER****CAUTION:**

As exhaust pipe has three way catalytic converter in it, it should not be exposed to any impulse. Be careful not to drop it or hit it against something.

Using the following specified torques, tighten bolts and nut ((a), (b), (c)) referring to "COMPONENTS" in this section.

**Tightening torque**

Exhaust pipe bolt (a): 50 N·m (5.0 kg-m, 36.5 lb-ft)

Exhaust pipe nut (to exhaust manifold):

50 N·m (5.0 kg-m, 36.5 lb-ft)

Heated oxygen sensor (b): 45 N·m (4.5 kg-m, 32.5 lb-ft)

Exhaust pipe nut (c): 60 N·m (6.0 kg-m, 43.5 lb-ft)

Prepared by  
**SUZUKI MOTOR CORPORATION**

Overseas Service Department

1st Ed. April, 2000

Printed in Japan

Printing: April, 2000

736