

CONTENT

1. RESOURCE FILE.....	4
1.1. HDI DIRECT INJECTION SYSTEM	4
1.1.1. General HDI system diagram	5
1.1.2. Vehicle safety instructions.....	7
1.2. FUEL CIRCUIT	7
1.2.1. Fuel circuit components	9
1.2.2. High pressure fuel pump	11
1.2.3. High pressure fuel injection rail	15
1.2.4. Injectors	16
1.3. INTAKE AIR CIRCUIT AND GAS RECYCLING	20
1.4. COMPUTER: FUNCTIONS AND SENSORS	24
1.4.1. Operating phases.....	30
1.4.2. Defect display - downgraded operating modes	41
2. USER DOCUMENTS.....	47
2.1. INSTALLATION GUIDE AND INSTRUCTIONS	47
2.2. HI-TEC BATTERY CHARGER.....	48
2.3. MODEL DESCRIPTION.....	51
2.3.1. Engine plate.....	52
2.3.2. Control plate	54
2.3.3. Computer plate	56
2.3.4. Measuring examples.....	58
3. TRAINING DOCUMENTS.....	68
3.1. Identify the sensors and actuators.....	68
3.2. Study of the diesel supply circuit	72
3.3. Study of the air supply circuit	73
3.4. Study of system operation.....	74
3.5. Injector control	75
3.6. Measuring with the MT-H9000 model.....	77
3.7. QUIZ	78



1. RESOURCE FILE

1.1. HDI DIRECT INJECTION SYSTEM

Common rail direct injection systems have been widely distributed since the early years of the new millennium, and currently hold a monopoly for diesel engines in private vehicles. These systems are more efficient in terms of reducing pollution, driver comfort, costs and reliability.

The system represented by the MT-H9000 model was developed by BOSCH. This model can be used to determine an ideal injection law. The fuel is injected at very high pressure thanks to a common injection rail and electrohydraulic injectors.

The common injection rail stores fuel at very high pressure. Injection pressure can reach up to 1350 bars at maximum settings.

The engine management computer integrates many parameters:

- engine speed,
- engine water temperature,
- air temperature,
- fuel pressure and temperature,
- atmospheric pressure,
- position of the accelerator pedal.

These input parameters can be used by the computer to:

- determine the duration of injection and fuel pressure,
- trigger pre-injection if necessary (to reduce combustion noise) and a main injection,
- control the amount of fuel injected (electrical control).

Benefits of the electronic management of the system:

- driver comfort (50% more torque at low engine speeds and 25% more power),
- improved engine performance (fuel consumption reduced by approximately 20%),
- reduced pollutant emissions (CO₂, CO, HC and carbon particles).

Post-injection, combined with a NO_x catalyser, will reduce the level of nitrogen oxides, in addition to other pollutants.

Note:

Battery charge level is important for system operation: system operations will be disturbed if battery voltage below 10 V. The computer will save a defect if battery voltage is above 17.5 V or below 7 V.



ID	Description	PSA no.
1	Intake manifold pressure sensor	1312
2	Turbocompressor	-
3	Air flowmeter	1310
4	Air filter	-
5	Catalytic converter	-
6	Supercharging pressure relief valve capsule	-
7	Exhaust gas recycling valve	-
8	Recycling solenoid control valve	1253
9	Supercharging pressure solenoid control valve	1233
10	Injection computer	1320
11	Atmospheric pressure sensor (integrated in the injection computer)	1320
12	Diagnostic indicator	V1300
13	Centralised diagnostic jack	1203
14	Inertia switch	-
15	Double injection relay	-
16	Battery	-
17	Powered fan(s)	1511-1512
18	Cooling compressor	8020
19	Engine water temperature warning indicator	V4020
20	Engine water temperature logometer	4026
21	Accelerator pedal position sensor	1261
22	Vehicle speed sensor	1620
23	Pre-heating indicator	V1150
24	Tachometer	9000
25	Immobiliser	8221-8630
26	Brake pedal contactor	-
27	Onboard computer (as per version)	-
28	Clutch pedal contactor	7306
29	Engine water temperature probe	1230
30	Feed pump	1211
31	Fuel tank	-
32	Fuel heater	-
33	Pre-post heater	1150
34	Fuel cooler	-
35	Fuel filter	-
36	High pressure fuel regulator	1322
37	High pressure fuel pump (with three pistons)	-



ID	Description	PSA no.
38	De-activator for the 3 rd piston of the high pressure fuel pump	1208-6
39	Additional heating (immersion heater or boiler)	1725
40	Additional heating control relay	1322
41	Injectors	1131-1132-1133-1134
42	Air/air heat exchanger	-
43	Camshaft sensor	1115
44	Speed sensor	1313
45	Pre-heating spark plugs	1160
46	High pressure fuel injection rail	-
47	High pressure fuel sensor	1321
48	Fuel temperature probe	1310

1.1.2. Vehicle safety instructions

In view of the very high pressure (1350 bars) in the high-pressure fuel circuit, the following instructions must be complied with:

- the engine must be shut down before all operations on the high-pressure fuel circuit,
- wait for 30 seconds after the engine has shut down before starting any operation.

Note: this waiting period is necessary to allow atmospheric pressure to be re-established in the high-pressure fuel circuit.



With the engine running, systematically remain at a distance far enough to prevent serious injury in the event of fuel spray (do not bring your hand near to a leak from the high pressure fuel circuit).

1.2. FUEL CIRCUIT

ID	Description	PSA no.
1-4	Injectors (electrically controlled)	1131-1132-1133-1134
5	High pressure fuel injection rail	-
6	Fuel temperature probe	1221
7	High pressure fuel sensor	1321
8	Fuel cooler	-
9	Pre-filter	-
10	Feed pump (low pressure)	1211
11	Fuel tank	-
12	Fuel filter + water settler + low pressure regulator	-
13	Water drain screw	-
14	Fuel heater	-
15	High pressure fuel pump	-
16	High pressure fuel regulator (on high pressure pump)	1322
17	De-activator for the 3 rd piston of the high pressure pump	1208-6



Fuel circuit synoptic diagram

-  A Return circuit (to fuel tank)
-  B Low pressure circuit
-  C High pressure circuit

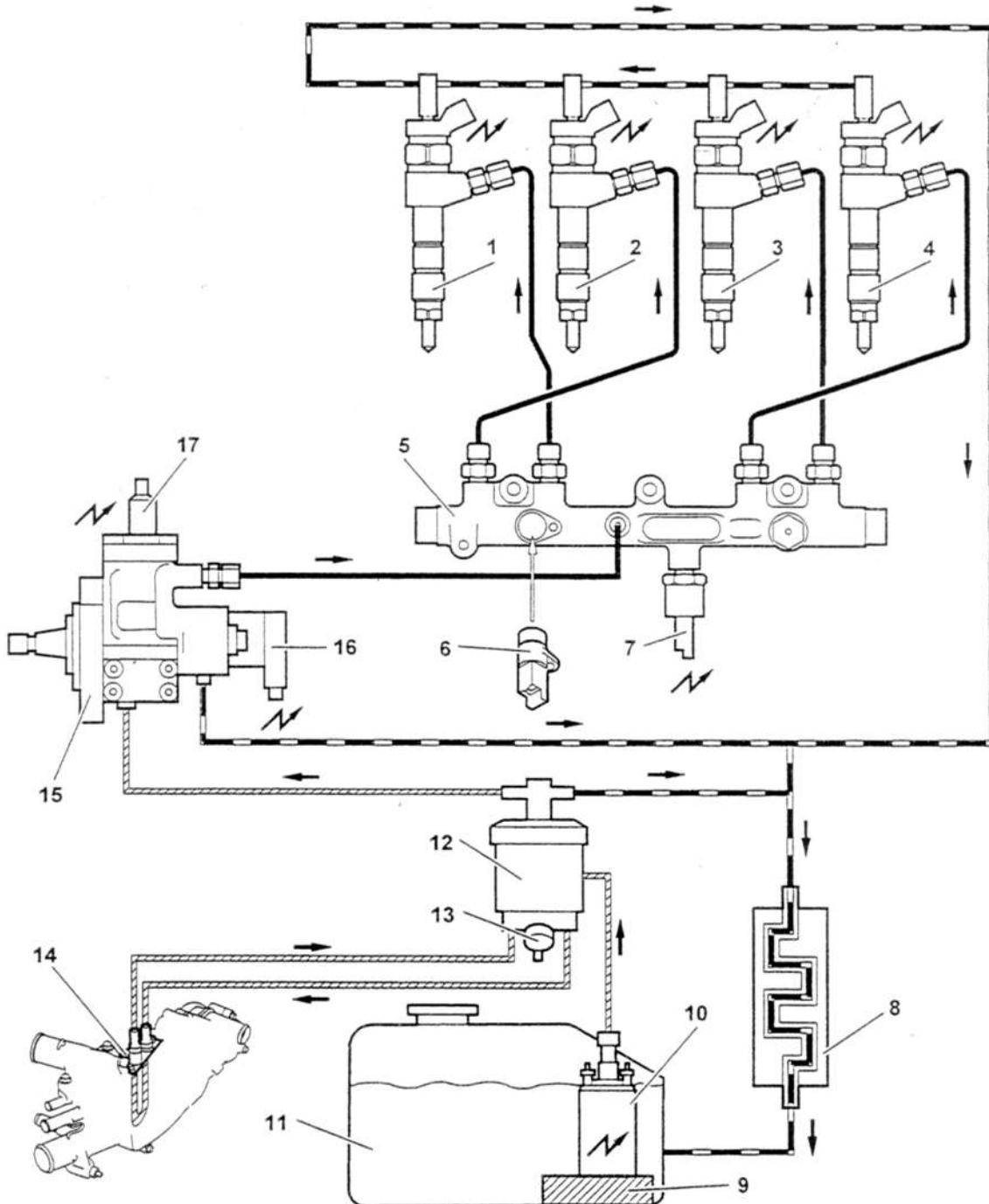

1.2.1. Fuel circuit components

Tank

The fuel tank is identical to traditional diesel tanks.

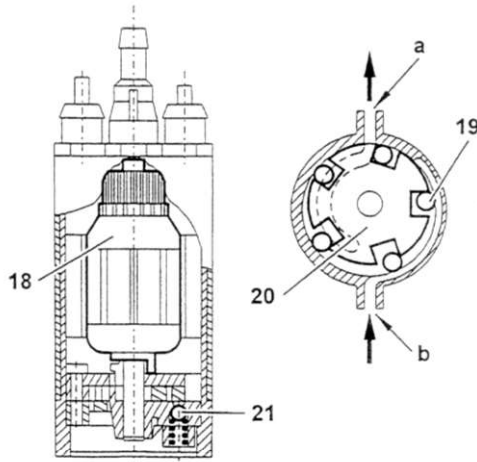

Feed pump

- a - Fuel outlet
- b - Fuel inlet
- 10 - Feed pump
- 18 - Electrical motor
- 19 - Rollers
- 20 - Rotor
- 21 - Relief valve (≈ 7 bars)
- 22 - Fuel float gauge

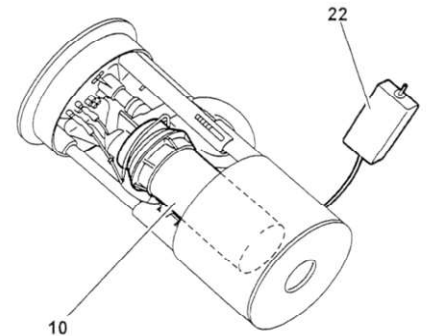

Purpose of the feed pump:

- supply fuel to the high pressure pump,
- ensure the necessary pressure in the low pressure circuit.

Description of the BOSCH pump (EKP3 model):

The feed pump is immersed in the tank. The pump is supplied with 12 V by the double injection relay from initial contact, for 2 to 3 seconds with the engine running.

Electrical particularities:

Control system: injection computer + double injection relay

Allocation of connector channels:

- Channel 1: fuel level signal,
- Channel 2: feed pump supply (+12V),
- Channel 3: not used,
- Channel 4: feed pump ground,
- Channel 5: fuel gauge ground.

Installation:

The feed pump is integrated in the gauge/pump module, which is installed in the fuel tank.

The module integrates a prefilter (300 μm filtration) and a gauging function, with the fuel time function (as per version).

Fuel filter with thermostatic valve

Purpose of the fuel filter:

- filtering fuel (filtration threshold: 5 μm),
- water settling,
- controlling fuel heating (thermostat),
- controlling pressure in the low-pressure fuel circuit (built-in pressure regulator).

Description:

(fuel flow in direction shown by arrows).

- c - Return to fuel tank
- d - Heated fuel inlet (water outlet unit)
- e - Outlet: to water box
- f - Fuel inlet
- g - Outlet: high pressure fuel pump
- 23 - Low-pressure regulator (valve)
- 24 - Thermostat
- 25 - Filter.

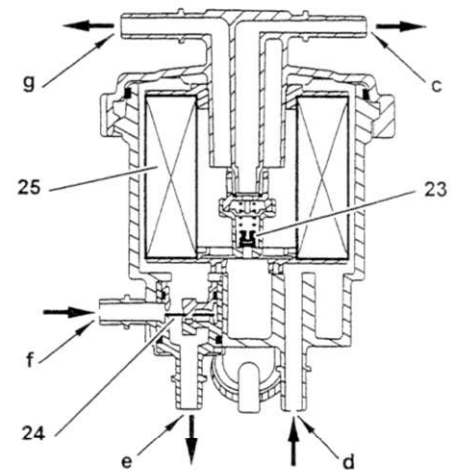

Pressure in the circuit: approx. 2.5 bars.

Fuels filter replacement intervals: every 60,000 km.

Fuels filter drainage intervals: every 20,000 km.

High-pressure and low-pressure circuits are automatically drained after the replacement of a fuel filter.

Purpose of the thermostat:

- for cold starts, the thermostat will reroute some of the fuel to the fuel heater,
- for hot starts, the thermostat will disable fuel heating.

Description:

The thermostat consists of a bi-metal strip which is deformed depending on the temperature of the fuel.

(D): Fuel temperature: <15°C

- the strip is separated from the seat,
- the direct route to the filter is closed off,
- the fuel is heated when coming into contact with the water outlet unit

(E): Temperature between 15°C and 25°C; the thermostat is partially separated from the seat; some of the fuel is reheated.

(F): Fuel temperature > 25°C

- the thermostat bi-metal strip is in contact with the seat
- the fuel routes directly to the filter

Fuel cooler

The high-pressure pump laminates the fuel flow from the feed pump; the fuel temperature rises. A fuel cooler must be used.

Description: The fuel cooler consists of a metal coil promoting the exchange of heat between the fuel and the air.

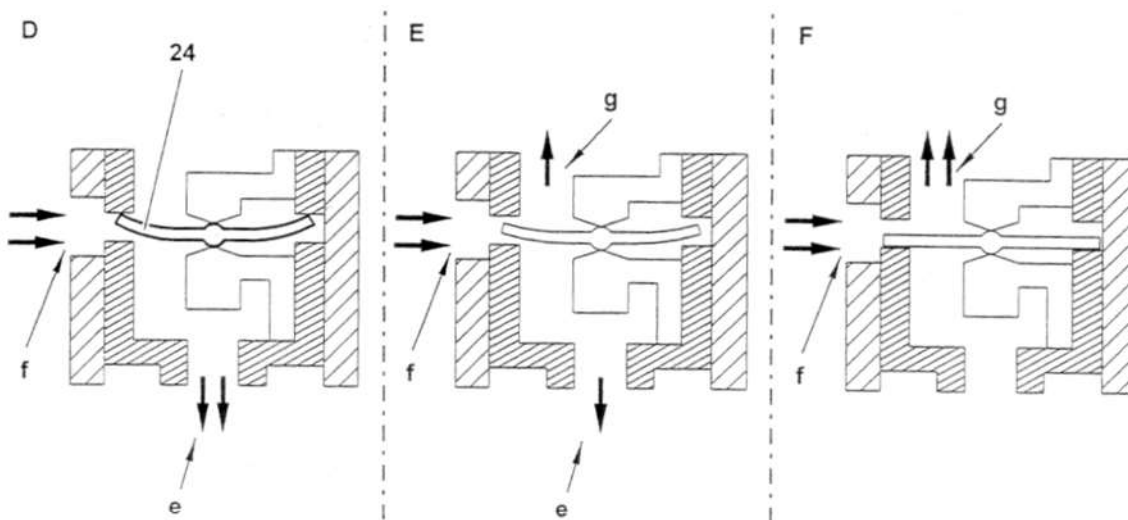

Fuel flow in direction shown by arrows

- e - Outlet: heater (engine water outlet unit)
- f - Fuel inlet
- g - To filter
- 24 - Thermostat
- D - Fuel temperature <15°C
- E - Temperature between 15°C and 25°C
- F - Fuel temperature > 25°C

Installation: The fuel cooler is secured under the vehicle bodywork.



Fuel heater

Purpose: heating the fuel to operating temperature.

Description:

This unit heats the fuel routed by the thermostat (fuel filter). The fuel heater consists of a tube immersed in the engine coolant.

Heat is exchanged between the coolant and the fuel.

Location: in the engine water outlet unit.

Two types of assembly are used:

- Metal water outlet unit: the heater is built into the engine water outlet unit.
- Plastic water outlet unit: the heater is fitted onto the water outlet unit.

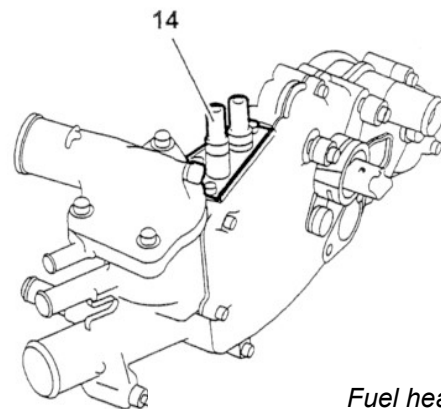

Fuel heater

1.2.2. High pressure fuel pump

BOSCH pump

(Type CP1 with 3 pistons)

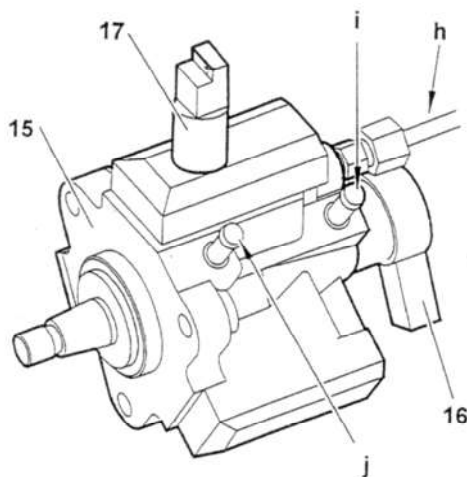

- h - high pressure fuel outlet (to high-pressure fuel rail)
- i - return to fuel tank
- j - fuel supply,
- 15 - high pressure fuel pump,
- 16 - high pressure fuel regulator,
- 17 - De-activator for the 3rd piston of the high pressure fuel pump.
- 2 - Lubrication valve
- 3 - Eccentric pump shaft
- 4 - High-pressure piston

High pressure fuel pump:

- supplies fuel at high pressure (between 200 and 1350 bars); the pressure is controlled by the regulator (16),
- feeds the injectors via the high pressure injection rail,
- driven by the transmission belt (drive ratio: 0.5).

Unused fuel returns to the tank (via the fuel cooler).

Components connected to the high pressure fuel pump:

- high pressure fuel regulator (16)
- de-activator for the 3rd piston of the high pressure fuel pump (17).

The pressure supplied by the pump reaches 200 bars when the engine starts, after 1.5 engine rotations.

Note: the high-pressure pump is not a distributor pump and no adjustment is required.

Maximum input power: 3.5 kW.

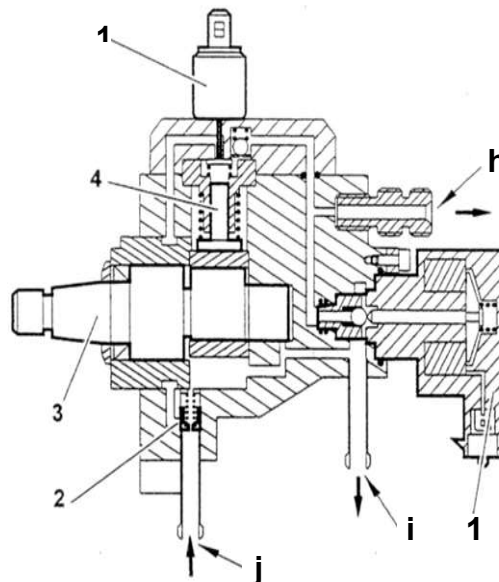

Pump lubrication valve (2):

The lubrication valve is used to grease the high-pressure fuel pump if the feed pressure drops too low

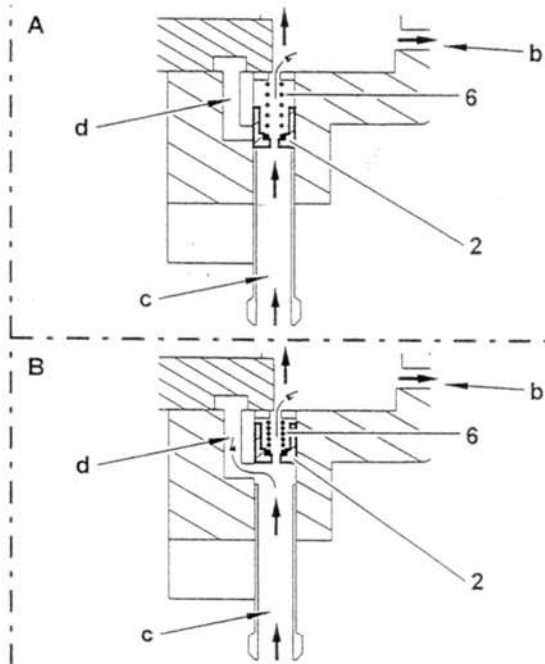

- b** - return to tank
- c** - feed pump fuel inlet
- d** - to high pressure stage
- 2** - lubrication valve
- 6** - return spring
- A** - difference between the feed pressure and the pressure in the return circuit < 0.8 bar
- B** - difference between the feed pressure and the pressure in the return circuit > 0.8 bar

The fuel enters the pump via inlet (c) and crosses the lubrication valve (2).

Difference between the feed pressure and the pressure in the return circuit < 0.8 bar (A):

- fuel pressure inadequate to open the valve (2);
- the fuel crosses the valve (with hole drilled);
- the fuel is used to lubricate and cool the high-pressure pump.

Difference between the feed pressure and the pressure in the return circuit > 0.8 bar (B):

- the fuel opens the valve (2);
- the fuel used for lubrication purposes crosses the valve;
- the fuel is routed to the high-pressure stage (d) of the pump.

Creating high pressure:

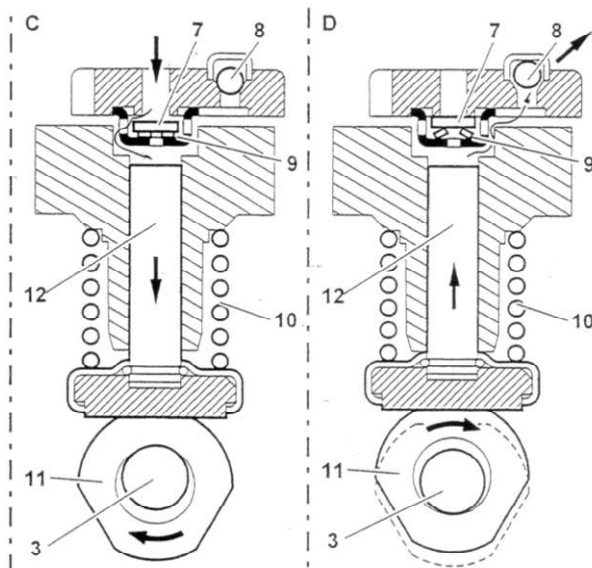

- 3** - Eccentric pump shaft
- 7** - Fuel intake valve
- 8** - Ball exhaust valve
- 9** - Return spring, intake valve
- 10** - High pressure piston returns spring
- 11** - Drive cam
- 12** - High-pressure piston

- C** - Intake phase.
- D** - Exhaust phase.

The high-pressure fuel pump shaft consists of one cam.

The injection pistons are supplied with fuel by the low-pressure circuit inside the pump.

The fuel is sucked in by the piston during the intake phase.

Intake (C):

- the feed pump routes the fuel through the intake valve (7);
- the return spring pushes the piston back on the cam;
- the piston creates negative pressure in the sheath.

Exhaust (D):

- bottom dead centre exceeded;
- the increase in fuel pressure closes the intake valve (≈ 1 bar);



- the fuel is trapped in the chamber;
- the high pressure pump cam pushes the piston;
- fuel pressure increases;
- the exhaust valve (8) opens.

After the top dead centre, the exhaust valve closes after the pressure drops.

De-activator for the 3rd piston of the high pressure fuel pump (1208-6)

Purpose: Reduce the input power to the high pressure fuel pump if the vehicle is used with a low load and rapidly limit the high-pressure level in the event of an incident.

The volume of fuel discharged will reduce while this element is controlled:

- reducing the power to the high pressure fuel pump,
- limiting fuel heating (less laminated flow).

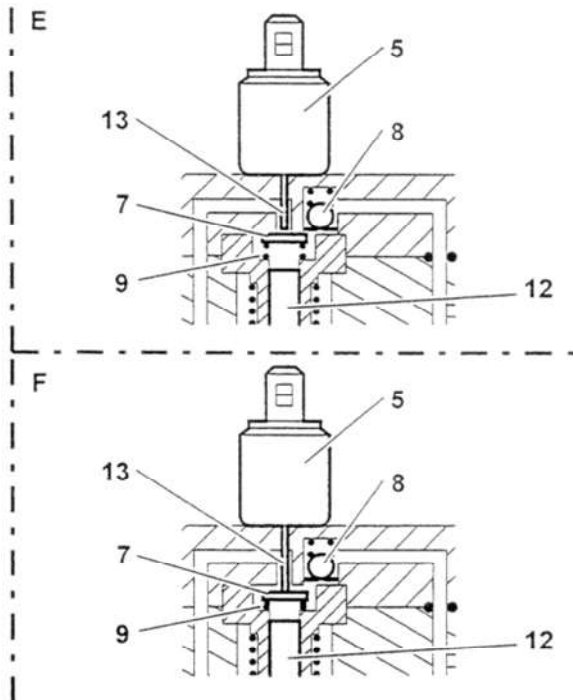

- 5 - de-activator for the 3rd piston of the high pressure fuel pump
- 7 - fuel intake valve
- 8 - exhaust valve
- 9 - return spring, intake valve
- 12 - high-pressure piston
- 13 - push rod

- E - Use of the three pistons.
- F - Use of two pistons.

The de-activator for the 3rd piston of the high pressure fuel pump consists of:

- a solenoid valve,
- a push rod activated by the action of the solenoid valve.

De-activation of the 3rd piston of the high pressure fuel pump not supplied: (E)

- the fuel intake valve (7) is held in contact with its seat by the spring (9),
- the cylinder is closed,
- the action of the pump shaft cam creates pressure,
- fuel pressure adequate to lift the exhaust valve (8),
- the fuel is routed to the high pressure pump outlet.

De-activation of the 3rd piston of the high pressure fuel pump supplied: (F)

- the push rod (13) lifts the intake valve (7) from its seat,
- the cylinder is open: no pressure is created,
- the fuel is routed to the low-pressure part of the high-pressure pump.

Note: If the fuel temperature exceeds 106°C, the high pressure fuel pump will only operate with 2 pistons.

This solenoid valve is controlled using the ground by the injection computer (logic command):

- Supplied: pump operates with 2 pistons
- Not supplied: pump operates with 3 pistons.

High pressure fuel regulator

Purpose:

The high pressure fuel regulator is used to control the high pressure pump outlet.
The fuel high pressure level is controlled by modifying the calibration of the regulator.

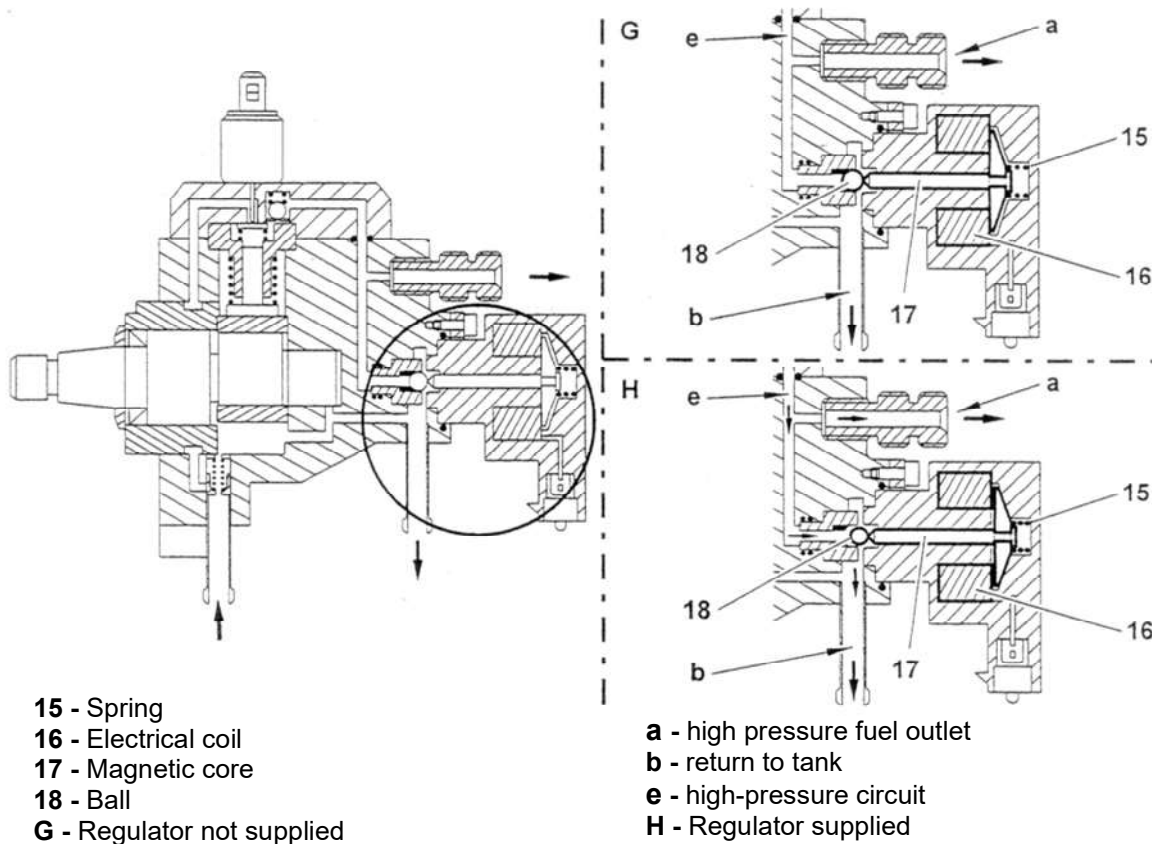

The high-pressure fuel regulator includes two pressure control circuits:

- The electrical circuit: the computer directly modifies the high pressure level controlling the solenoid valve of the high pressure fuel regulator.
- The mechanical circuit: used to maintain minimum pressure and dampen pulses.

1 - Mechanical control

Pressure varies in the high pressure fuel circuit.
High fuel pressure increases during the exhaust phase of a pump piston.
High fuel pressure decreases when an injector opens.
The ball flutter (18) dampens these pressure variations.

2 - Electrical control

High pressure fuel regulator not supplied:

- high fuel pressure opposes the mechanical action of the spring (15),
 - the regulator opens when the high fuel pressure is higher than the spring pressure (approx. 100 bars),
 - the fuel released by the high-pressure regulator returns to the tank via outlet (b)
- When the engine is stopped, no residual pressure will remain in the high pressure fuel circuit (30 seconds after engine shutdown).

Controlling the increase in pressure:

- the injection computer supplies the high pressure fuel regulator with a duty cycle current,
- the high pressure fuel regulator coil drives the magnetic core (magnetic force),
- the force applied to the ball is the total of the spring forces (15) and the magnetic force of the core,
- the cutout rating of the high-pressure regulator will increase.

Controlling the decrease in pressure:

- the injection computer will reduce the duty cycle supplied to the coil of the high-pressure regulator,
- the force applied to the ball decreases,
- the high pressure fuel regulator coil drives the magnetic core (magnetic force),
- the cutout rating of the high pressure fuel regulator will decrease.



Electrical part:

High pressure fuel regulator not supplied: pressure limited to approx. 100 bars.

Particularities of the electrical control:

- command: injection computer (via the ground),
- control type: variable voltage (duty cycle),
- max. duty cycle = max. voltage = maximum pressure,
- min. duty cycle = min. voltage = minimum pressure.

Do not carry out any operation on the high-pressure circuit within 30 seconds of shutting down the engine.

1.2.3. High pressure fuel injection rail

Purpose:

The high pressure injection rail between the high-pressure pump and the injectors is used to:

- store the amount of fuel required for the engine, regardless of the operating phase,
- dampen the pulses created by the injectors,
- interconnect the high pressure circuit components.

Components connected to the high pressure injection rail:

- high pressure fuel supply pipe,
- injector supply pipes,
- fuel temperature probe,
- high pressure fuel sensor.

Note: Check the tightening torques for the components of the high pressure fuel circuits (injectors, high pressure fuel sensor, high-pressure pipes).

- k - Outlets to injectors
- i - Fuel high pressure supply
- 5 - High pressure injection rail
- 6 - Fuel temperature sensor
- 7 - High pressure fuel sensor.

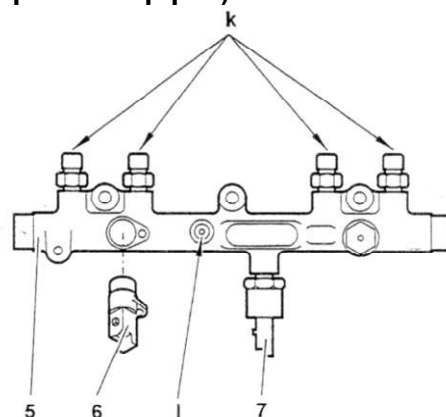

The high pressure injection rail is in forged steel.
The size of the rail is suitable for the engine configuration.
Location: on the cylinder head.



Fuel temperature probe (1221)

Purpose of the injection computer depending on the information received:

- calculate the density of the fuel,
- adjust fuel flow.

This is an NTC sensor fitted on the high pressure injection rail.

Resistance at 25 °C = 2400 Ohms

Resistance at 80°C = 270 Ohms.

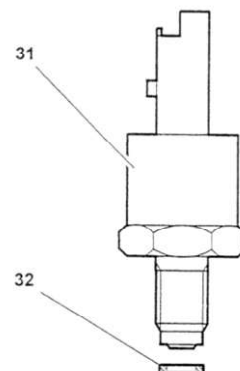

31 - high pressure fuel sensor.

32 - metal joint

Fuel pressure sensor (1321)

Purpose:

Measure the pressure in the high pressure fuel injection rail.

Depending on the information received, the injection computer will:

- determine the amount of fuel to inject = Injection time
- control high fuel pressure in the injection rail.

A piezoelectric sensor is used. This sensor consists of a strain gauge.

The sensor supplies voltage in proportion to the fuel pressure in the high pressure injection rail.



Electrical part:

Allocation of connector channels:

channel 1: ground **channel 2:** pressure data (0 - 5 V) **channel 3:** supply + 5V

Voltage supplied for a pressure of 100 bars: approx. 0.5V

Voltage supplied for a pressure of 300 bars: approx. 1.3V

Location: on the high pressure injection rail.

1.2.4. Injectors

Purpose: They inject the fuel required for engine operation.

26 - Injector solenoid valve connector

27 - Injector control solenoid valve

p - High pressure fuel supply (injection rail)

m - Tank return (return circuit)

Injectors consist of two parts:

- electrical controls,
- the fuel spray system.

Injectors are controlled electrically by the injection computer. The control solenoid valve is located in the upper part of the Diesel injector, and is bolted to the injector casing (37) (diagram below is given).

The injectors include several holes, promoting the spraying of the air/fuel mixture. They are adapted to the engine version, e.g.: 5 holes with a diameter of 0.16mm, (or 5 x 0.2 mm or 6 x 0.15 mm).

The amount of fuel injected depends on the following parameters:

- duration of the electrical command (injection computer),
- injector opening speed,
- hydraulic speed of the injector (number and diameter of holes),
- fuel pressure in the high pressure injection rail.

The fuel can be injected during the following phases:

- pre-injection,
- main injection,
- post-injection.

The fuel is injected directly in the piston head.

Injectors are interconnected by the return circuit.

Fuel pressure in the return circuit is approximately 0.7 bar.

Description:

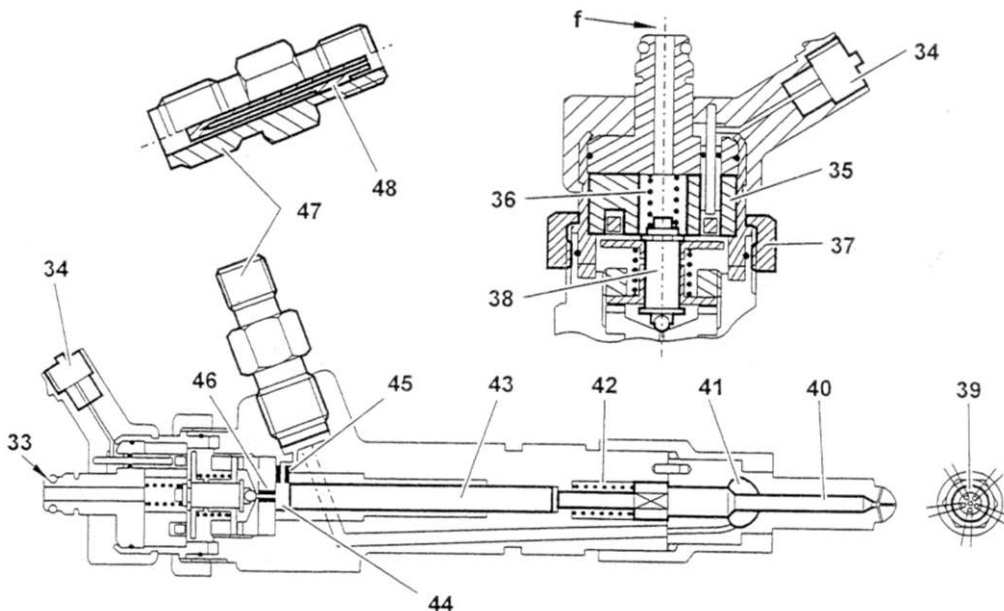
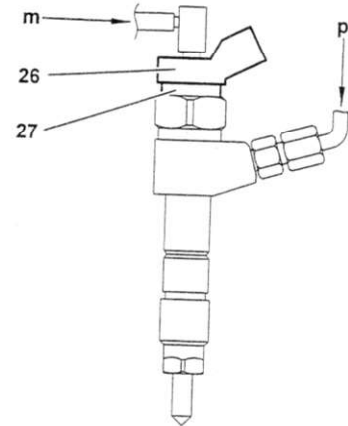

- | | |
|--|--|
| f - Tank return | 34 - Electrical connector |
| 35 - Control solenoid valve coil | 36 - Control solenoid valve spring |
| 37 - Nut | 38 - Control solenoid valve needle |
| 39 - Injector nozzle | 40 - Injector needle |
| 41 - Pressure chamber | 42 - Injector spring |
| 43 - Control piston | 44 - Control chamber |
| 45 - Supply nozzle | 46 - Return circuit nozzle |
| 47 - High pressure inlet connection | 48 - Laminar-flow filter in the connection. |

The fuel pressures used in the system prevent the direct electronic control of injectors. Injectors open due to the pressure differential between the control chamber (44) and the pressure chamber (41).

The injector needle (40) is held in contact with its seat by the spring (42).

The injector needle (40) is located under the control piston (43) (free in its bore hole).

The head of the control piston (43) appears in the control chamber (44).

The control chamber connects to:

- the high pressure fuel circuit via the nozzle (45),
- the tank return circuit via the nozzle (46).

The control chamber (44) is isolated from the tank return circuit by the solenoid valve needle and its ball (38). The solenoid valve needle is held in contact with its seat by the spring (36).

Fuel is distributed identically between the two chambers (44 and 41). Nozzle (46) is larger than nozzle (45).

The solenoid valve needle lifts when the solenoid valve coil is supplied (magnetic field).

No maintenance is required for the laminar-flow filter (48).

Principle of injector lifting:

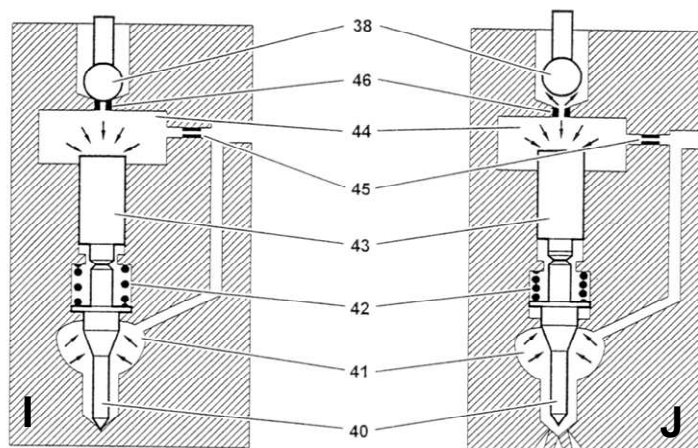

- | | |
|--|-------------------------------------|
| 38 - Control solenoid valve ball and needle | 40 - Injector needle |
| 41 - Pressure chamber | 42 - Injector spring |
| 43 - Control piston | 44 - Control chamber |
| 45 - Supply nozzle | 46 - Injector opening nozzle |
| I - Injector closed | J - Injector open |

Injector closed

The force applied in the form of high pressure is identical for the control chamber (44) and the pressure chamber (41). The control piston is static (in contact with the injector needle). The injector needle (40) is held in contact with its seat by the spring (42). The increase in pressure in the high pressure fuel rail closes the injector.

Opening the injector

The injection computer supplies the control solenoid valve, and the solenoid valve needle (38) rises:

- a fuel leak is created at the nozzle (46),
- the fuel enters via the nozzle (45), but does not offset the leak at the nozzle (46),
- the pressure equilibrium between the two chambers (44 and 41) is disturbed,
- the pressure in the pressure chamber (41) lifts the injector needle,
- the control piston (43) rises again,

- the fuel is injected (sprayed in the piston head).
The injection will continue if the solenoid valve of the injector is supplied.

Closing the injector

The injection computer cuts the supply to the solenoid valve of the injector:

- the solenoid valve spring holds the needle of the solenoid valve in contact with its seat,
- the nozzle (46) is blocked,
- the fuel leak to the return circuit stops,
- the injector closes due to the increased pressure in the control chamber (44) and the action of the spring (42).
- the pressure equilibrium between the two chambers (44 and 41) is re-established,
- the injector is ready for a new cycle.

The solenoid valve opens completely at each control pulse (even at minimum flow). Injector opening will depend on the duration of the command:

- Short solenoid valve command:
 - The control piston maintains a certain degree of inertia,
 - The injector needle is only slightly lifted,
 - Only a small amount of fuel is injected,
 - Injection pressure is below the pressure in the injection rail.
- Long solenoid valve command:
 - the control piston and the injector needle are completely lifted,
 - a large amount of fuel is injected,
 - injection pressure is equal to the pressure in the injection rail.

The mechanical behaviour of the injector is saved as a map.
Maximum needle lift: approx. 0.06 mm.

IMPORTANT!

The injector must not be supplied with 12 V: this would destroy the solenoid valve.

Injector coil control:

Injector command current:

- 51** - initial phase
- 52** - steady-state phase
- 49** - initial current
- 50** - steady-state phase
- 53** - end-of-command
- a** - amperes
- T** - time

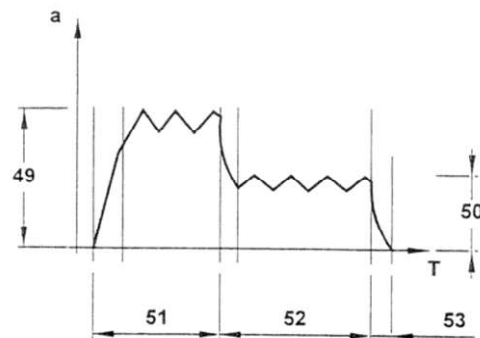

Solenoid valve power supply consists of two phases:

- an initial phase (initial voltage and current)
- a steady-state phase (steady-state voltage and current).

Initial phase

The initial phase triggers the rapid rise of the solenoid valve needle.

The injector solenoid valve is supplied:

- with voltage of approximately 80 volts,
- with current of approximately 20A

The initial phase is limited to a few milliseconds (0.3 ms)

Steady-state phase

The steady-state phase continues to supply the solenoid valve while limiting the electrical power absorbed.

The injector solenoid valve is supplied:

- with voltage of approximately 50 volts,
- with current of approximately 12A



Summary of operations:

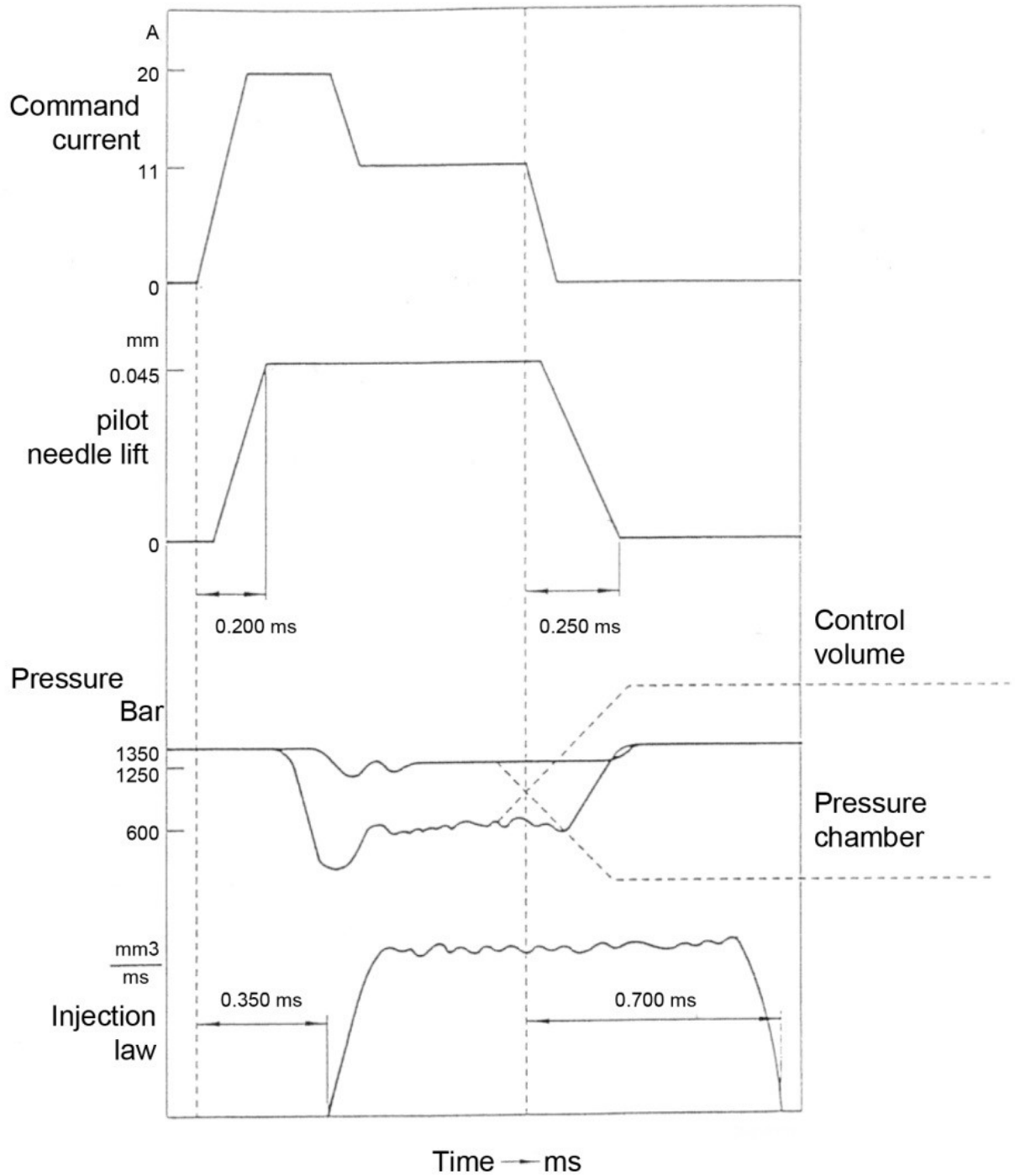

1.3. INTAKE AIR CIRCUIT AND GAS RECYCLING

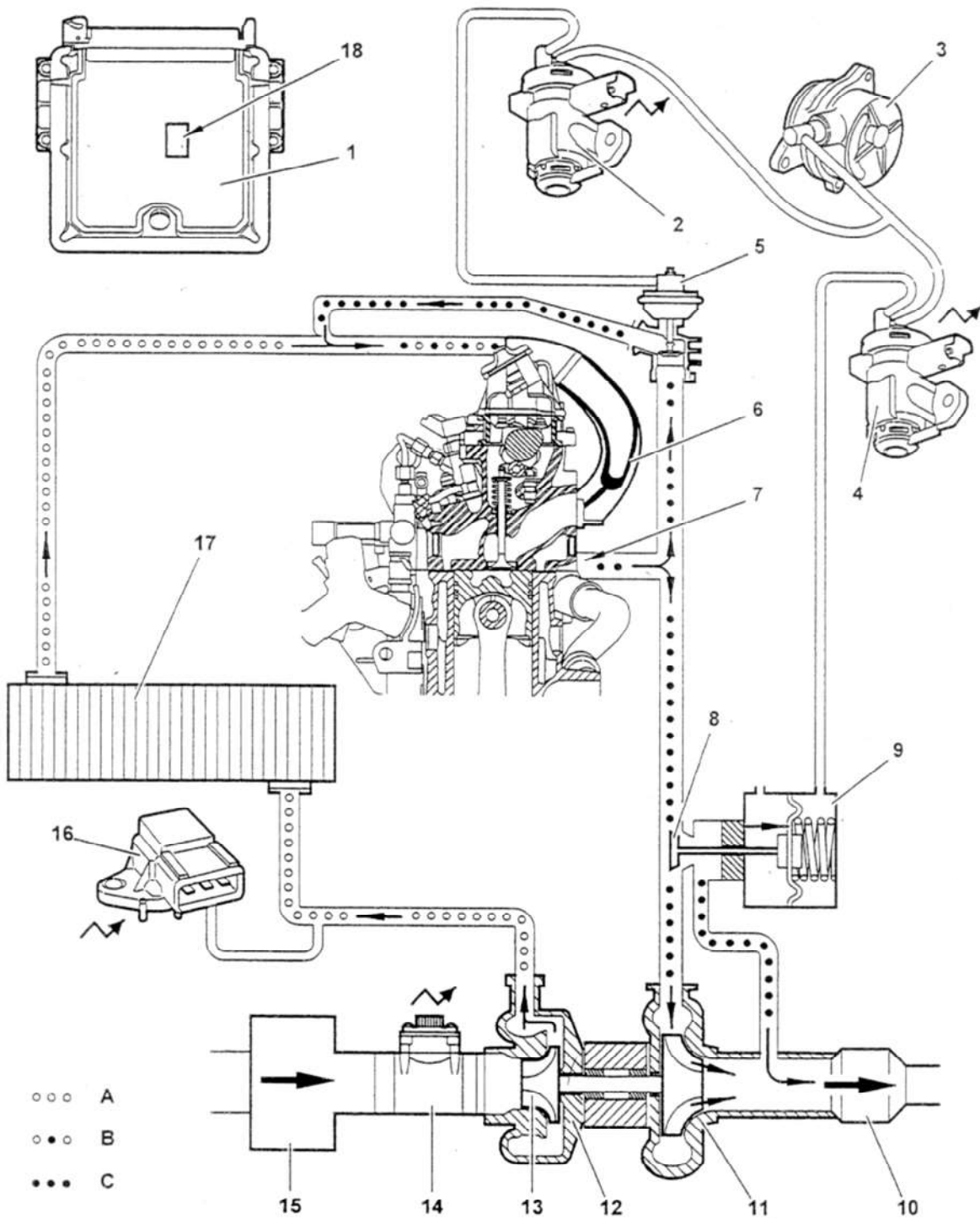

ID	Description	No. on wiring diagrams
1	Injection computer	1320
2	Recycling solenoid control valve (EGR)	1253
3	Vacuum pump (vane-type, driven by the camshaft)	-
4	Supercharging pressure solenoid control valve (as per model)	1233
5	Exhaust gas recycling valve (EGR)	-
6	Air intake distributor	-
7	Exhaust gas manifold	-
8	Supercharging pressure relief valve (negative-pressure based control)	-
9	The pneumatic control capsule for the supercharging pressure relief valve (on the turbo compressor) controls on the basis of negative pressure.	-
10	Catalytic converter	-
11	Exhaust turbine	-
12	Turbocompressor	-
13	Air intake turbine	-
14	Air flowmeter + air temperature probe	1310
15	Air filter	-
16	Intake manifold pressure sensor (as per version)	1312
17	Air/air heat exchanger	-
18	Atmospheric pressure sensor (integrated in the injection computer)	1320

Air filter

Replacement intervals: every 60,000 km

Turbocompressor

Purpose: the turbo compressor can supercharge the engine with air.

Description:

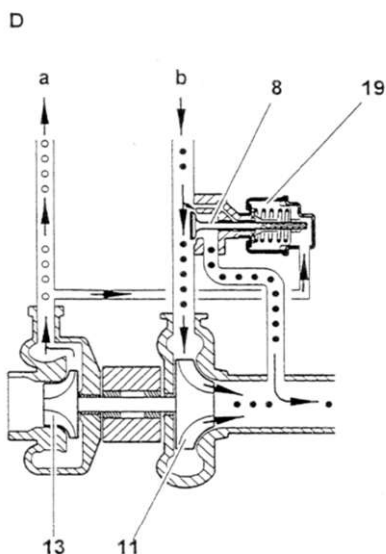

- a - to intake distributor
- b - gas from exhaust manifold
- 8 - supercharging pressure relief valve
- 11 - exhaust turbine
- 13 - air intake turbine
- 19 - Pneumatic control capsule for the relief valve: pressure-based controls.

Supercharging pressure is controlled on the basis of the air pressure in the intake manifold.

When the calibrated value of the capsule is exceeded (19):

- the supercharging pressure relief valve opens,
- the speed of the exhaust turbine decreases,
- the supercharged air pressure drops.

When the supercharged pressure drops, the supercharger pressure relief valve closes.

Atmospheric pressure sensor (1320)

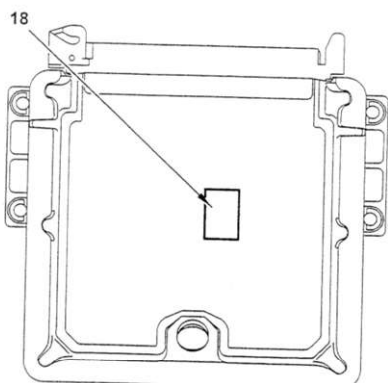

Purpose:

The sensor measures atmospheric pressure. Depending on the information received, the injection computer will:

- determine the density of the air
- disable recycling in case of use at high altitudes.

Air density will decrease with altitude.

Description: A piezoelectric sensor is used. This sensor consists of a strain gauge. The sensor supplies voltage in proportion to atmospheric pressure.

The atmospheric pressure sensor is integrated in the injection computer.

Important! The sensor is an integral part of the computer.



Air/air heat exchanger

Purpose: Cool the air entering the cylinders and therefore increase the density of the air in the cylinders. The increase in the density of the air entering the cylinder improves engine performances.
Location: on the front panel of the vehicle.

Vacuum pump

Purpose: Create the negative pressure required to control the following components:

- the pneumatic control capsule for the supercharging pressure relief valve (as per model),
- pneumatic control capsule for the exhaust gas recycling valve,
- brake amplifier (as per version).

Description:

- 3 - Vacuum pump
- 20 - Relief valve (built-into the outlet connection)

Vane-type pump driven by the engine camshaft.
 A relief valve built into the pump isolates the negative pressure circuit of the brakes, with the engine shutdown.

The relief valve:

- maintains reserve negative pressure in the brake amplifier,
- maintains braking assistance for a few braking operations.

Location: On the cylinder head, at the end of the camshaft on the gearbox side.

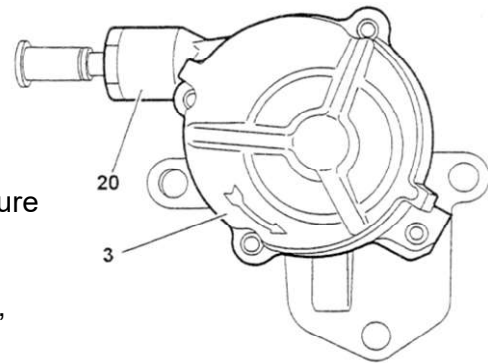

Air flowmeter (1310)

Purpose: Measure the flow of fresh air entering the engine.
 Depending on the data received, the injection computer will:

- determine the degree of recycling of exhaust gases,
- limit the formation of smoke during transient phases, acceleration, and deceleration by correcting fuel flow.

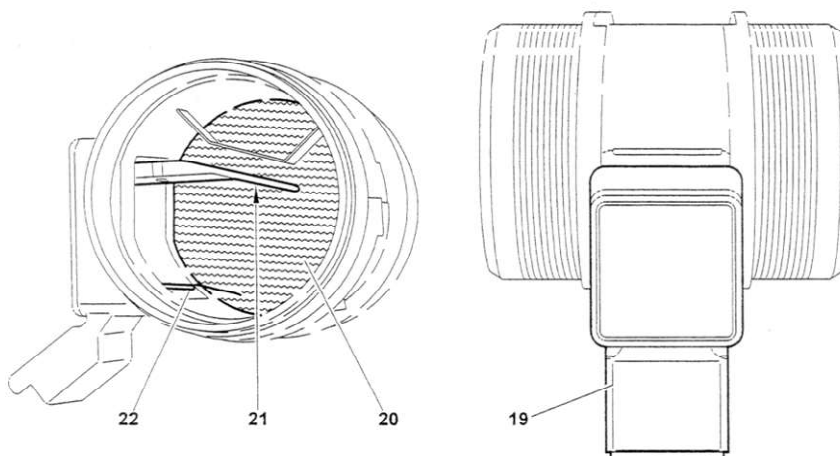

- 19 - Electrical connector
- 21 - Hot film

- 20 - Protective grid
- 22 - Air temperature probe

The flowmeter consists of the following components:

- a metal plate (hot film) used to determine the mass of the air in the circuit,
- an air temperature probe.

The metal plate is very thin, and consists of:

- a heating resistor,
- a measuring resistor.

The injection computer supplies current to the heating resistor to maintain the metal plate at a fixed temperature.

The air passing through the flowmeter cools the metal plate: the measuring resistance (NTC) varies.

The computer associates the measuring resistance value to an airflow.

Important! Do not touch the metal plate, use of a blower is prohibited.



Allocation of connector channels:

- channel 1: air temperature data
- channel 2: + 12 V (+ bat)
- channel 3: ground
- channel 4: unused
- channel 5: airflow information
- channel 6: ground.

Location: The air flowmeter is located between the air filter and the turbocompressor.

Air temperature probe (1310)

Purpose: The air temperature probe informs the computer of the temperature of the air entering the engine.

Depending on the data received, the computer will apply:

- trigger additional heating,
- calculate the density of the air.

Important! The air temperature probe is built into the air flowmeter.

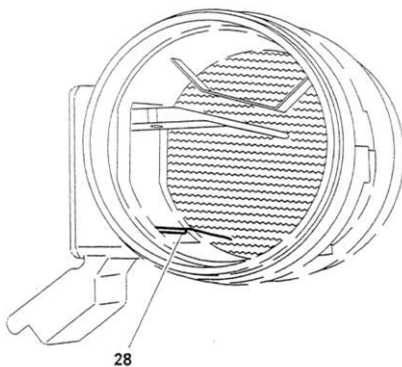

Description:

The probe consists of an NTC (negative temperature coefficient) type resistor.

The higher the temperature, the lower the resistance.
Resistance at 25°C = 3300 ohms.

Recycling solenoid control valve (EGR) (1253)

Purpose: Control the opening of the exhaust gas recycling valve (EGR).

Description: Proportional solenoid valve controlled with duty cycle voltage. This valve is connected to atmospheric pressure and the negative pressure created by the vacuum pump.

- d - "Use" outlet,
- f - White marking,
- e - Negative pressure inlet (vacuum pump)
- g - Atmospheric pressure inlet
- 23 - Electrical connector

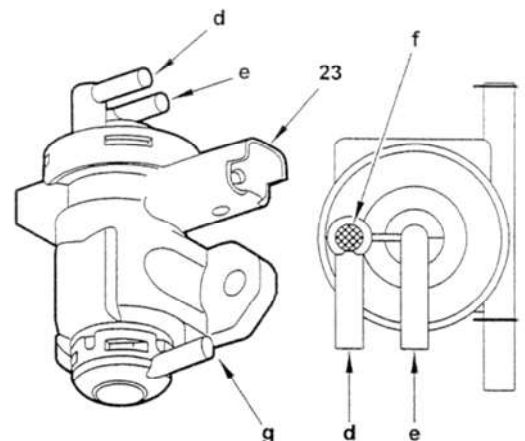

The solenoid valve connects the vacuum pump and the recycling valve capsule for exhaust gases (EGR valve).

The pressure supplied by the solenoid valve is between atmospheric pressure and the negative pressure created by the vacuum pump.

When the solenoid valve is supplied, the exhaust gases are recycled. Exhaust gases are recycled progressively, as managed based on a map (injection computer)

Electrical part:

- Command: injection computer (via the ground),
- Type of control: variable voltage (duty cycle)
- Maximum supply: maximum negative pressure, resistance at 25 °C: 5 ohms.
- No supply: no negative pressure (atmospheric pressure)

Electronic devices are located in the engine compartment on a support surface resting on the dashboard.

Exhaust gas recycling valve (EGR)

Purpose: Controlling the volume of exhaust gas recycled. The exhaust gas recycling device (EGR) can reduce the amount of nitrogen oxide (Nox) discharged by the exhaust.

The amount of nitrogen oxide is reduced by reinjecting part of the exhaust gases into the cylinders.

Recycling phases are saved as maps (injection computer).

Description:

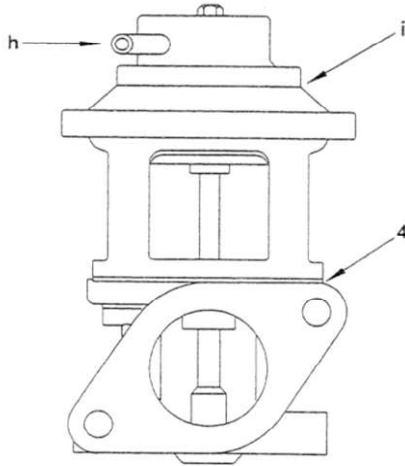

h - Negative pressure inlet (recycling solenoid control valve)

i - Pneumatic control capsule

4 - Recycling valves

Important: The recycling valve closes when no pneumatic controls apply (negative pressure).

When the pneumatic control capsule is supplied with negative pressure by the recycling solenoid control valve:

- the recycling valve opens,
- some of the exhaust gases are absorbed by the engine (air intake distributor).

Location: The recycling valve is located on the exhaust manifold.

Catalytic converter

The converter (fitted on the exhaust system) reduces the amount of the following components discharged into the atmosphere:

- carbon monoxide (CO)
- unburnt hydrocarbons (HC)

A two-way catalyst is used.

Post-injection combined with a 4-way Nox catalytic converter will reduce the level of nitrogen oxide emitted.

1.4. COMPUTER: FUNCTIONS AND SENSORS

Injection computer (1320)

Purpose: The computer manages the system as a whole.

The computer software includes:

- Decontamination and injection control functionalities,
- Driver comfort strategies,
- An immobiliser function,
- Emergency strategies,
- Management and control of powered fans and warning indicators (as per version),
- Control of the unit water heater system (as per version),
- Diagnostic with defects saved.

The computer controls the following elements electronically:

- Injectors,
- supercharging pressure solenoid control valve,
- high pressure fuel regulator,
- recycling solenoid control valve,
- pre- and post-heater, post-heating cutoff,
- De-activator for the 3rd piston of the high pressure fuel pump.



The computer emits the signal:

- engine speed ==> meter display,
- instantaneous consumption ==> vehicle computer,
- cooling cutout,
- authorisation to start the water heater (as per version).

Downloadable Flash Eprom computer. This computer integrates the atmospheric pressure sensor.

Particularity: injector control

The computer includes a power stage able to provide the very high control current required for the operation of the injectors.

The injectors are controlled by two computer stages.

- Stage 1: controlling injectors 1 and 4.
- Stage 2: controlling injectors 2 and 3.

Injector control stages can be used to obtain:

- peak 80 V supply: the voltage required when the injectors start to lift,
- 50 V supply: the voltage required to hold the injectors open.

The control stages built into the injection computer each include a capacitor, which stores the energy required to control the injectors.

Between injections, the computer sends pulses to the unused injector coil. These pulses create induced voltage to charge the corresponding control stage (capacitor).

Important! If an anomaly is detected for the supply line of an injector, charging will not be possible for this control stage.

A safety system within the computer can be used to disconnect the control stages at engine shutdown.

Pre-post heating function

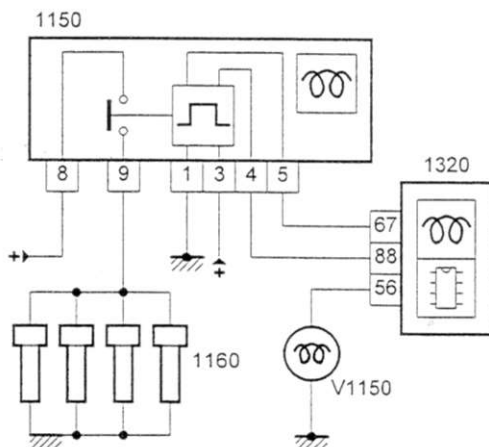

Synoptic:

- 1150** - pre-heater
- 1160** - pre-heating spark plugs
- 1320** - engine control computer
- V1150** - pre-heating indicator



11V spark plug with a total length of 107 mm

Pre-heater spark plugs (1160):

The spark plugs heat the combustion chamber. They consist of:

- a heating resistor,
- a metal protective envelope.

Pre-heater (1150):

Pre- and post-heating times are determined by the injection computer. If the pre-heater fails, the computer will save a defect.

Allocation of connector channels:

- channel 1: ground,
- channel 2: not connected,
- channel 3: + 12V post-contact,
- channel 4: computer inlet,
- channel 5: pre-heater diagnostic,
- channel 6: supply to pre-heating spark plugs,
- channel 7: + 12 V (permanent +).

Engine cooling function (built into the injection computer)

The injection computer:

- controls the start-up and shutdown of the powered fans for engine cooling and the air conditioning function,
- controls post-ventilation (max. 6 minutes),
- turns on and off the water temperature warning indicator on the panel (as per version),
- controls the water temperature logometer on the panel (as per version),
- diagnoses powered fan operation,
- acquires engine water temperature,
- manages downgraded modes if one of the system components fails.

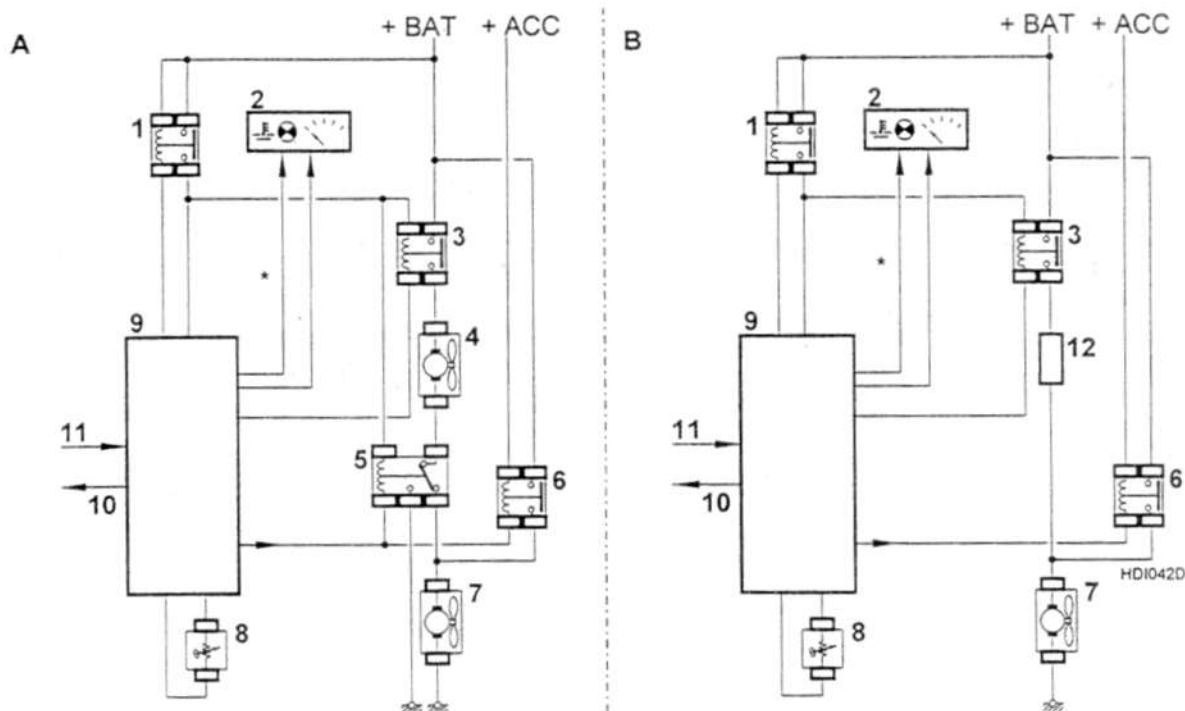

- 1 - double injection relay
- 3 - relay 1
- 5 - relay 2
- 7 - powered fan 2
- 9 - injection computer
- 12 - resistor
- A: Assembly with two powered fans

- 2 - panel (warning indicator + logometer)
- 4 - powered fan 1
- 6 - relay 3
- 8 - engine water temperature probe
- 10 - air conditioning, compressor and clutch relay control
- 11 - air conditioning ON information
- B: Assembly with one single powered fan

"Air conditioning on" information is provided by the air conditioning computer. When the injection computer receives this information, the powered fans are operated at low speed.

Engine water temperature probe (1220)

Purpose: The water temperature probe informs the computer of the temperature of engine coolant.

Depending on the temperature, the computer:

- adjusts pre-heating and post-heating time,
- adjusts start-up flow,
- adjusts idle engine speed,
- enables the recycling of exhaust gases,
- adjusts fuel flow,
- limits the flow injected if the temperature of the coolant is critical (anti-boiling function),
- controls the start-up of the powered fans (see engine cooling function),
- controls the logometer on the panel (as per model),
- controls the warning and pre-warning indicators (as per model).



Description (two types of assembly):

Blue 3-way probe:

The probe consists of two NTC (negative temperature coefficient) type resistors.

Allocation of the connector channels and electrical characteristics:

- channel 1 - channel 2: NTC for the injection computer, resistance at 20°C = 6200 Ohms,
- channel 3 - ground: NTC for the panel logometer, resistance at 30°C = 1925 Ohms.

Green 2-way probe:

The probe consists of an NTC (negative temperature coefficient) type resistor.

The higher the temperature, the lower the resistance. Resistance at 20 °C = 6250 Ohms.

The engine water temperature probe is located in the waterbox outlet.

27 - Engine water temperature probe

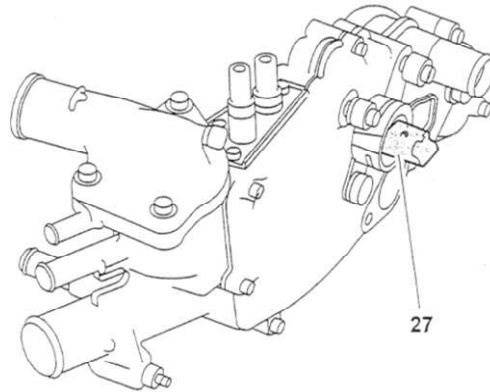

Powered fan unit

Assembly with one or two powered fans (2 options).

Important: the trigger thresholds for powered fans depend on the vehicle.

Assembly with 2 powered fans:

- low speeds can be obtained by supplying the powered fans in series (6V).
- high speeds can be obtained by supplying the powered fans in parallel (12V).

The transition from low to high speed is immediate; however, before switching to high speed, the powered fans are systematically operated at low speed for 3 seconds.

Post-ventilation:

The computer controls the post-ventilation system if the water temperature exceeds a certain threshold at engine shutdown.

Post-ventilation procedures are applied at low speeds and last for a maximum of 6 minutes after engine shutdown.

If battery voltage is less than 10.5V when the contact is cut, post-ventilation is prohibited.

Downgraded modes:

If the water temperature probe fails:

- the injection computer will operate the powered fans at high speed,
- the injection computer will command the water temperature warning indicator to flash on the control panel.

Double injection relay

Purpose: The double injection relay is controlled directly by the injection computer.

The first relay in the double relay is used to supply the following components:

- feed pump,
- supercharging pressure solenoid control valve,
- air flow meter,
- recycling solenoid control valve.

The second relay in the double relay is used to supply the following components:

- injection computer (power part),
- powered fan control relays.

The double relay will continue to be supplied for 4 seconds after the contact is cut, or for 6 minutes with post-ventilation.



If the immobiliser system requests for the injection computer to be blocked (specific computer channel):

- the computer will supply the double injection relay,
- the computer will be resupplied by the double injection relay (power),
- the injection computer and the immobiliser system can dialogue,
- at the end of the dialogue, the injection computer will cut the supply to the double injection relay.

Brake contactor

Purpose: The contactor enables the injection computer to manage driver comfort.

Location: In the pedal unit.

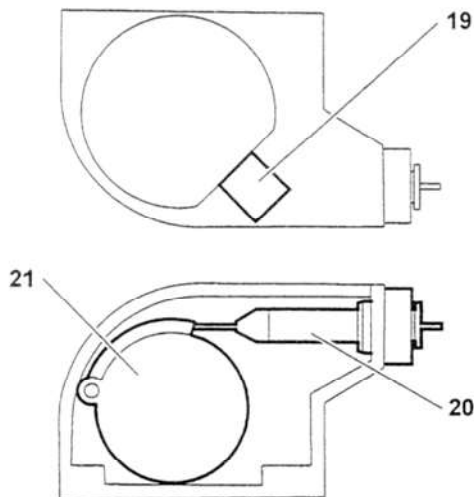

Accelerator pedal sensor (1261)

Purpose:

A cable connects the sensor to the accelerator pedal:

- the sensor records driver input (acceleration, deceleration),
- it transfers the information to the injection computer.

Based on this data, the computer will determine the amount of fuel to inject (injection pressure and time).

Description:

- 19** - electrical connector
- 20** - accelerator cable
- 21** - drive cam

The accelerator pedal sensor supplies two signals (voltage).

The voltage value for one signal is equivalent to half of the other signal.

Information from connector channels is constantly compared to detect any defects.

This pedal sensor is contactfree.

Electrical part:

Allocation of connector channels:

channel 1: output signal 1,
channel 3: 5 V

channel 2: output signal 2
channel 4: ground.

Accelerator pedal released:

- voltage between the ground and channel 1: 0.5 V
- voltage between the ground and channel 2: 0.25V

Accelerator pedal pressed in:

- voltage between the ground and channel 1: 3.3 V
- voltage between the ground and channel 2: 1.65V

Location: in the engine compartment.

Engine speed sensor (1313)

Purpose:

This sensor can be used to determine:

- engine speed,
- the position of the moving parts.

Description:

The engine speed sensor is inductive and consists of:

- a permanent magnet,
- an electric winding.

The sensor emits an electrical signal when a tooth of the flywheel passes by (magnetic field modified).

The 58 teeth are used to determine engine speed.

The two missing teeth are used to determine the position of the crankshaft (no signal).

The air gap between the top dead centre sensor and the flywheel cannot be adjusted.

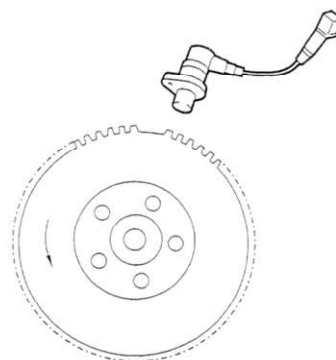

Electrical part:

Allocation of connector channels:

- channel 1: signal
- channel 2: ground.

Resistance between channels 1 and 2 = 50 ohms.

Particularities of the signals emitted: variable frequency alternative voltage.

Important: the sensor wire is not shielded; always route the bundle via the location designed for this purpose.

Location: opposite the teeth of the flywheel (on the clutch carter).

Vehicle speed sensor (1620)

Depending on the data received, the injection computer will:

- determine the speed of the vehicle (static or driving),
- determine the gear engaged,
- improve the idle engine speed while driving,
- optimise accelerations,
- reduce impacts.

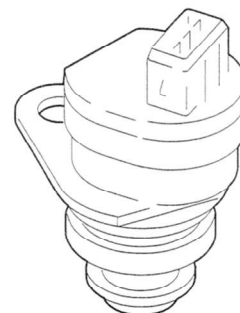

This sensor is based on "Hall effect" with 5 reference points per rotation.

Electrical part:

Allocation of connector channels:

- channel 1: + 12V
- channel 2: ground
- channel 3: signal.

Location: on the gearbox.

Camshaft sensor (1115)

Purpose:

Inform the computer of the position of the pistons. Depending on the signals received from this sensor, the injection computer will identify the top dead centre and synchronise injections with reference to the position of the pistons (sequential injection).

Description:

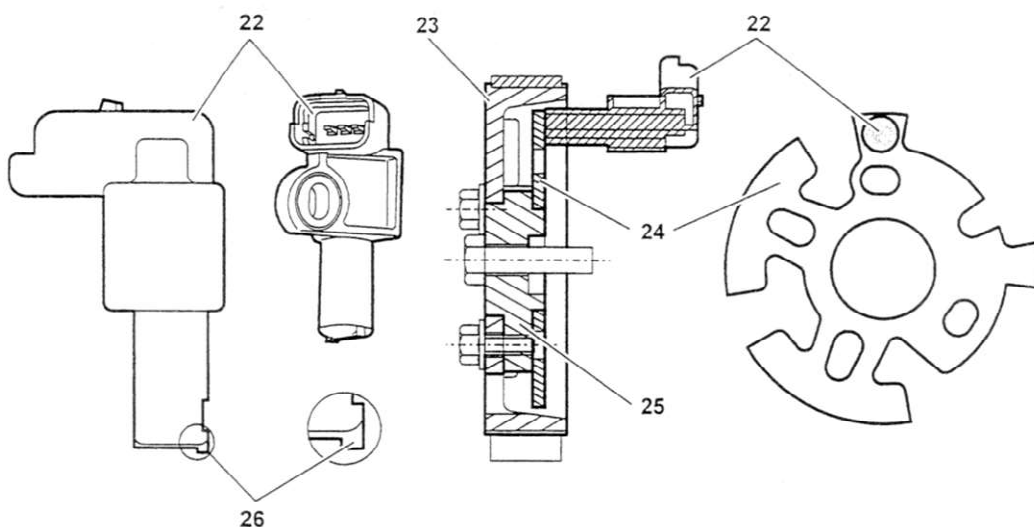

- 22 - Camshaft sensor
- 24 - Target driven by the camshaft
- 26 - Plastic pin.

- 23 - Camshaft pulley
- 25 - Camshaft hub

The camshaft sensor is based on "Hall effect". This sensor emits a squared signal to the injection computer.

The plastic pin (26) can be used to adjust the air gap at the factory, and is destroyed when the engine is started for the first time.

Important: If a sensor is reused during the after-sales phase, it is essential to maintain the air gap between the sensor and the target: 1.2 +0/+0.1 mm.

Electrical part:

Supply: injection computer

Allocation of connector channels:

channel 1: supply channel 2: signal channel 3: ground.

Signal emitted: voltage interval between 0 and 5 volts.

Presence of a metal ground opposite the sensor: 0V

Absence of a metal ground opposite the sensor: 5V

Location:

The camshaft sensor is located opposite a target driven by the camshaft pulley

1.4.1. Operating phases

Basic principles

The amount of fuel to be injected will depend on engine requirements.

With HDI applications:

- when engine speed is low (e.g. idle), diesel injectors may open slowly,
- injection pressure may be low.

When the engine has high energy requirements (e.g. control speed):

- the injectors must be opened more quickly,
- the fuel injection pressure must be much higher.

The injection system is designed with 3 degrees of freedom:

- injection pressure, by taking high-pressure fuel from the injection rail.
- fuel flow, by modifying injector opening time,
- start of injection.

HDI engine injections are defined on the basis of these three parameters collectively.

Basic mapping

The operating point of the injection is selected on the basis of the following three parameters:

- fuel pressure,
- fuel flow,
- start of injection.

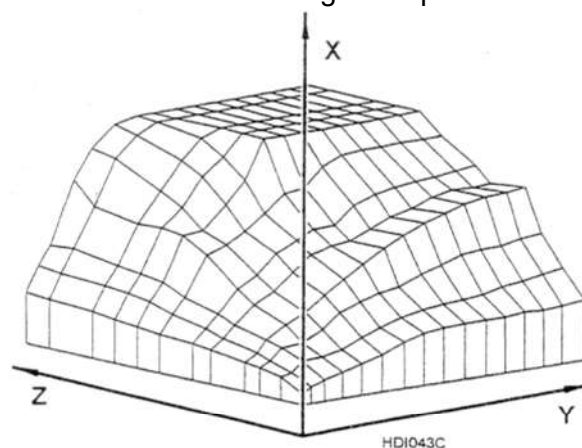

- x** - high fuel pressure
- y** - engine speed
- z** - amount of fuel (flowrate)



The computer has other maps in its memory.

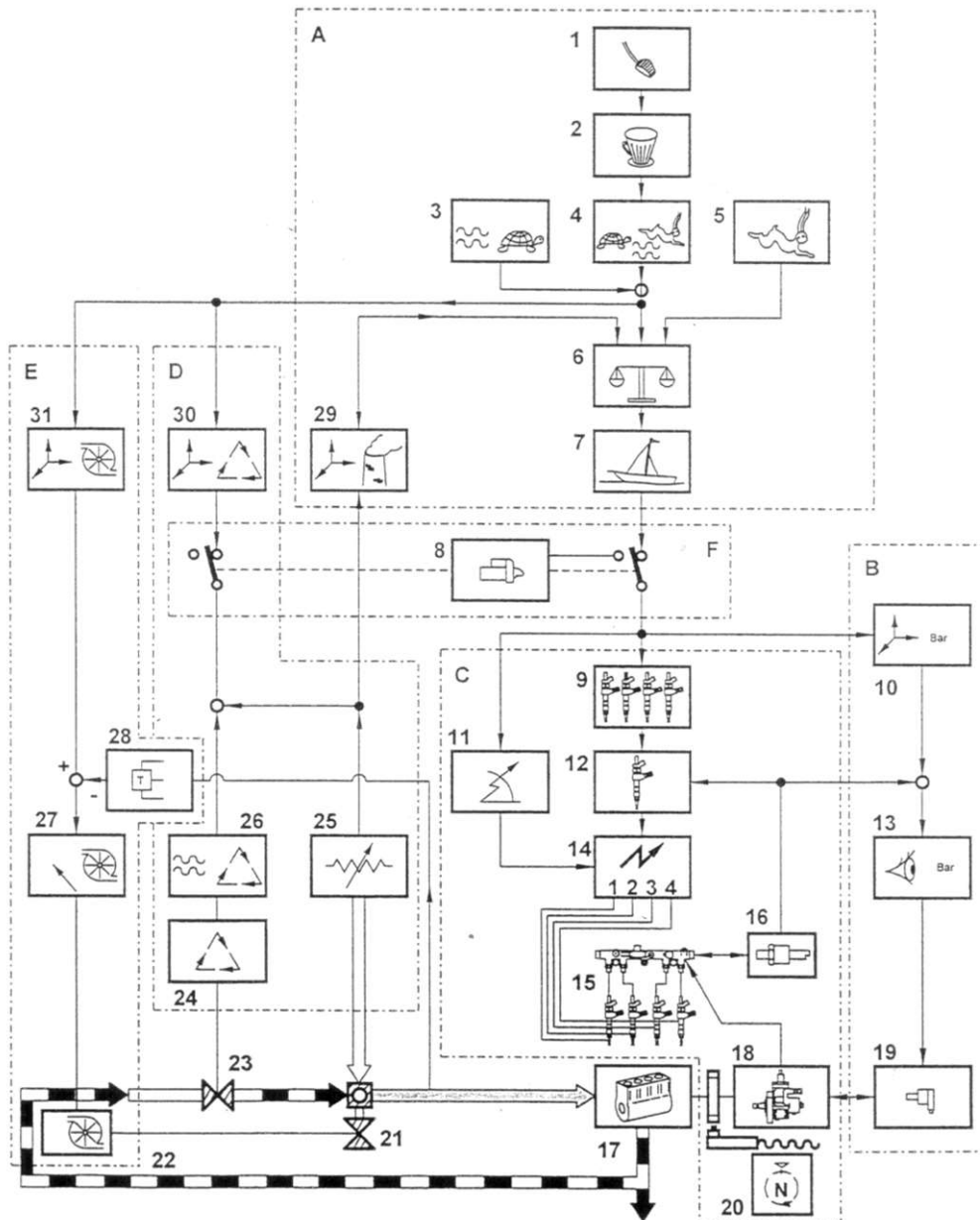

No.	Description
A	Calculating the amount of fuel to inject
B	Controlling high fuel pressure
C	Controlling injections
D	Controlling recycling
E	Controlling supercharging
F	Controlling engine start-up
1	Accelerator pedal
2	Accelerator pedal map
3	Idle control
4	Maximum acceleration map
5	Full speed curve
6	Minimum flow selection
7	Anti-impact control
8	Start-up control
9	Operating smoothness control
10	High fuel pressure map
13	High fuel pressure control
14	Injector control (1 - 3 - 4 - 2)
15	High pressure injection rail
16	High pressure fuel sensor
17	Engine
18	High pressure fuel pump
19	High pressure fuel regulator
20	Engine speed sensor
21	Supercharging pressure relief valve
22	Supercharging pressure solenoid control valve
23	Exhaust gas recycling valve
24	Recycling solenoid control valve
25	Air flowmeter
26	Gas recycling control
27	Supercharging control (as per version)
28	Intake manifold pressure sensor
29	Smoke limitation map
30	Recycling map
31	Supercharging map (as per version)



Purpose of the main maps

Accelerator pedal map:

This map is used to achieve the following, by filtering driver input:

- avoid significant variations in fuel flow (driver comfort),
- obtain good progression.

This map is used to calculate the amount of fuel to inject.

Full speed curve:

This curve is used to calculate the amount of fuel to inject:

- to avoid exceeding the fuel limits of the engine (mechanical limits),
- to avoid exceeding fuel limits based on air quantity.

Recycling map:

This is used to precisely determine the degree of recycling of exhaust gases.

The degree of recycling can be obtained based on the following parameters:

- amount of fuel to inject,
- atmospheric pressure,
- amount of air entering the engine (computed).

Smoke limitation map:

This map is used to limit the smoke emitted in transient phases.

Example:

- the driver requests a change in engine speed (or gear),
- the amount of fuel injected and the air quantity are no longer in equilibrium.

The map manages variation in fuel flow with reference to engine speed in order to remain within smoke emission limits.

High fuel pressure map:

This map is used to determine high fuel pressure depending on the amount of fuel to be injected.

This map takes engine speed and the amount of fuel calculated into consideration.

Determining the amount of fuel to inject

The amount of fuel to be injected is determined on the basis of driver input as indicated by the position of the accelerator pedal.

The computer takes the following information into consideration to determine the amount of fuel to inject:

- driver input (after filtering),
- smoke limitation map,
- full load curve (maximum mixture map),
- idle map.

Each map determines the amount of fuel to inject.

The amount of fuel to be ultimately injected will be decided according to a pre-determined level of priority.

**Note: If the engine is running at idle, the value provided by the map is taken into consideration.
The accelerator pedal is not taken into consideration during the start-up phase.**

The amount of fuel to inject:

- never exceed the value indicated by the full speed curve,
- never exceed the value given by the smoke limitation map.

The amount of fuel determined corresponds to the total amount of fuel:

- amount of fuel injected during pre-injection,
- amount of fuel injected during the main injection.



Specific corrections:

1 - idle control

The idle control can:

- modulate idle engine speed
- gradually accelerate from idle depending on engine heating,
- improve the idle engine speed while driving.

2 - injection cutout

Injections will cease with zero driver input if the amount of fuel calculated is equal to 0. (Vehicle showing down). Injections will restart at 2200 rpm.

Injections will cease due to overspeed if engine speed reaches 5300 rpm.

Note: If injection pressure is too high the computer will control the high pressure fuel regulator with a minimum duty cycle.

3 - Anti-impact control

This function refines the initial filtering operation applied by the accelerator pedal map.

Variations in fuel flow are modified progressively when accelerating or decelerating.

Controlling high fuel pressure

General management

- 15 - High pressure injection rail
- 18 - High pressure fuel pump
- 32 - High pressure fuel sensor
- 33 - Injection computer
- 34 - High pressure control

- the computer controls the pressure regulator with duty cycle voltage (as per version) based on the theoretical pressure value (high pressure fuel map),
- the high pressure fuel sensor measures the pressure in the high pressure supply rail,
- the computer corrects the duty cycle applied to the pressure regulator to obtain:
- Theoretical pressure = pressure measured in the high pressure fuel rail.

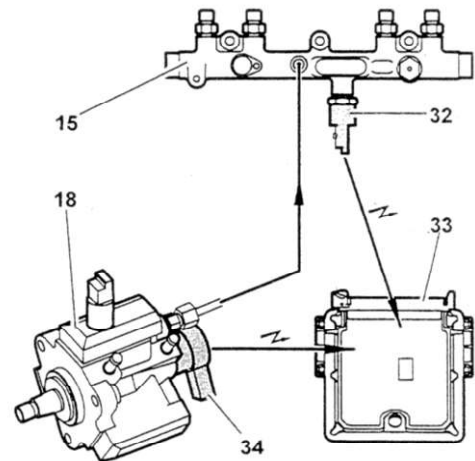

If the computer is unable to obtain the required pressure in the injection rail, the computer will record a "high pressure control" defect.

De-activator for the 3rd piston of the high pressure pump

Operating phases:

- a - 3-piston operation
- b - 2-piston operation
- c - 2- or 3-piston operation (hysteresis)
- d - engine speed
- e - amount of fuel

The pump operates with 3 pistons when the engine is running at idle.

From 2/3 full load and up to full load, the pump operates with 3 pistons.

When not operating at idle and below 2/3 of full speed, it operates with 2 pistons.

When fuel temperature is above 106°C, the computer de-activates the 3rd piston. (De-activator supplied).

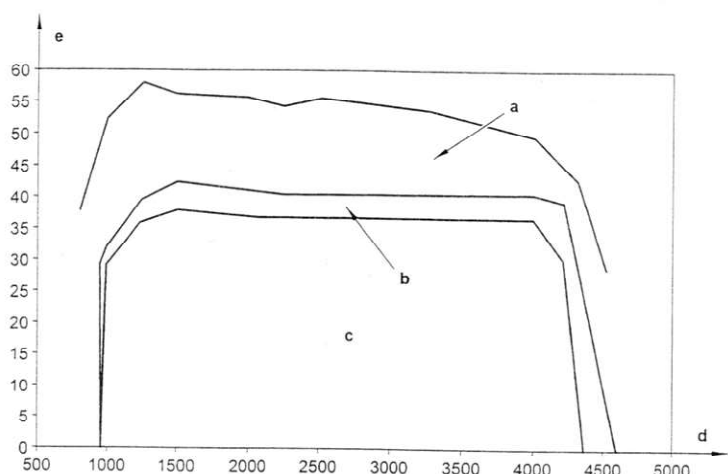

Injection

The computer acts independently on each injector to trigger each injection.

Injector supply order: 1 - 3 - 4 - 2.

The injection consists of:

- a pre-injection (noise abatement),
- a main injection,
- and possibly a post-injection (reduction in pollutants).

Determining the injection time

Injection time is determined on the basis of the following parameters:

- amount of fuel to inject,
- pressure available in the high pressure rail
- engine speed.

Injection timing can be divided into two parts over each engine cycle:

- pre-injection
- main injection.

Determining the start of the injection (timing):

The start of the pre-injection order is calculated on the basis of the amount of fuel to be injected.

The timing of the injection is corrected if the water temperature is low.

Determining the type of injection:

Pre-injection

The start of the pre-injection phase will be triggered before the main injection.

The computer triggers a pre-injection if engine speed is below 3200 rpm (noise abatement)

The pre-injection phase is omitted:

- above 3200 rpm,
- if high pressure is inadequate,
- if the rail degasses (start-up phase),
- if fuel flow is below a minimum threshold.

Pre-injection time is limited depending on the high-pressure available in the rail.

Main injection

Start and injection times vary, particularly depending on the use or omission of pre-injection:

The main injection phase is omitted if:

- rail pressure is inadequate (below 120 bars),
- maximum engine speed is reached.

Post-injection

Post-injection can reduce exhaust NO, NO₂ and No_x by adding fuel to the catalytic converter.

The post-injection phase consists of:

- the start of the injection depending on engine speed,
- injection time depending on engine speed, engine water and air temperature and atmospheric pressure.

The post-injection phase is omitted:

- if the temperature of the catalytic converter is outside of precise limits (upper and lower),
- if high pressure is inadequate,
- if the intake nozzle pressure sensor or turbocharger control and EGR solenoid valves or air flow meter malfunction.

Operating smoothness

Aim: reduce vibrations due to the engine operating at idle.

The computer determines operating smoothness based on:

- engine speed,
- crankshaft position.

The computer:

- analyses the different instantaneous speeds of rotation for each cylinder,
- calculates a customised fuel flow correction based on speeds of rotation.

Flow correction is expressed as an amount of fuel: X mg of fuel / injection input (-5 to +5 mg/injection).

Supercharging pressure control (as per model)

Supercharging pressure is calculated on the basis of engine speed and the amount of fuel to be injected.

The supercharging thresholds vary and depend on engine operating conditions (engine load).

Maximum supercharging pressure: 950 mb between 2500 and 3500 rpm.

Supercharging pressure can;

- be controlled,
- be managed as an open loop.

Supercharging pressure is not controlled at engine start-up.

Controlling supercharging pressure:

- ensures good driver comfort,
- ensures a good performance/consumption ratio.

Controlling exhaust gas recycling

23 - Recycling valve

24 - Recycling solenoid control valve

25 - Air flowmeter

32 - Injection computer

33 - Engine speed sensor

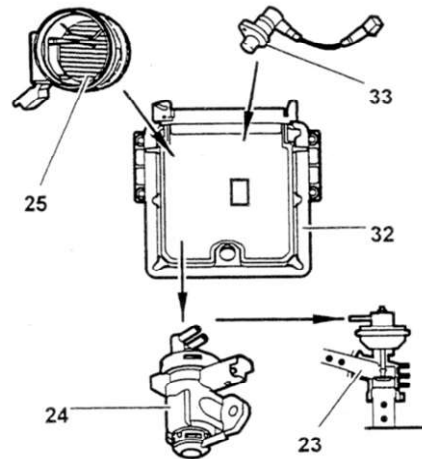

Recycling is proportional and managed based on the recycling level determined from the map:

- the computer controls the recycling solenoid valve with duty cycle voltage,
- the computer determines the degree of recycling based on the difference between the measurements of the air flowmeter and the air quantity computed to enter the engine (depending on engine speed and air temperature),
- the computer will correct the duty cycle applied to the recycling solenoid valve to obtain a theoretical degree of recycling = degree of recycling measured.

Conditions enables the recycling of exhaust gases:

- engine speed >780 rpm,
- engine load,
- engine water temperature > 60°C.

Disable recycling conditions:

- engine at full speed,
- engine speed above 2700 rpm,
- altitude above 1500 m.

Engine start-up

General management

The start-up phase initiates when the computer is powered up.

The computer controls the following components during start-up:

- feed pump (cutout after 3 seconds, if the starter fails to trigger),
- pre-heating spark plugs (if necessary),
- High pressure fuel regulator (pressurised)



The computer defines the high fuel pressure based on engine water temperature when the starter is activated.

For example, for a water temperature above $> 0^{\circ}\text{C}$, the setpoint pressure is 240 bars (control duty cycle for the high pressure regulator, 20%).

At start-up, the high pressure regulator is controlled with the duty cycle determined by the start-up map.

During this operating base, the high pressure fuel sensor is not taken into consideration.

Pressure is modulated if (any of the following):

- engine speed exceeds 20 rpm and at least 4 engine rotations have been completed.
- The pressure in the high pressure fuel rail has exceeded 150 bars.
- The start-up phase ends when the engine speed exceeds an engine speed threshold.

Note: the computer will only control the injectors if the pressure exceeds 120 bars.

With a low load, the setpoint pressure is 400 bars.

In the event of start-up difficulties, the computer will force pressure to rise by transmitting a maximum duty cycle command (duty cycle of 40% or even 80%).

If the high pressure fuel sensor fails:

- the computer will supply the high pressure fuel regulator until a pressure of 400 bars is obtained. (control duty cycle of the high pressure regulator = 21%),
- the pressure in the high pressure fuel rail is not controlled.

Rail degassing

With a new engine, or after opening the high pressure fuel circuit, the high pressure injection rail must be degassed.

If air is present in the high pressure circuit, this will delay the increase in pressure in the high pressure circuit.

After 10 seconds of starter operation, the computer will control the injectors to bleed the air in the circuit.

Important: If the minimum pressure of 120 bars is not achieved, injections will be disabled and the engine will not start.

Engine shutdown

When the contact is cut, the computer will shut down the engine by controlling the following components:

- control voltage of the high-pressure fuel regulator = 0 = minimum duty cycle,
- feed pump supply cutout,
- injection cutout (injector command),
- injector command stage cutout (in the computer).

Note: cutout commands are emitted in a different order at each engine shutdown operation to enable the computer to diagnose system components.

Engine operating safety

Overspeed protection

The computer monitors engine speed at all times.

Injections are stopped when the engine speed exceeds the maximum value. (approx 5300 rotations).

Note: The computer will control high pressure levels during the injection cutout phase.

Anti-boiling function

The computer integrates an anti-boiling strategy for the coolant in addition to an optimised cooling circuit. The amount of fuel injected is limited to avoid the coolant boiling during driving in severe conditions. (Towing to PTR, maximum speed).

The effect on the vehicle will lead to a reduction in speed for both towing and at maximum speed.



Pre- & post- heating

Pre-heating and post-heating times are determined by the computer depending on the temperature of the engine coolant.

Pre-heater operation

The duration of pre-heating depends on engine water temperature.

Engine water temperature	Duration of pre-heating (seconds)
- 30°C	16 s
- 10°C	5 s
0°C	0.5 s
10°C	0.25 s
18°C	0 s
40°C	0 s

Start-up heating

During the start-up phase, the spark plugs are supplied if:

- engine water temperature is below 20°C,
- the engine rotates at more than 70 rpm for 0.2 seconds.

Note: If the starter is not used after the indicator goes out, the spark plugs will remain supplied for a maximum of 10 seconds.

Post-heater operation

Post-heating involves extending spark plug operation for a maximum period of sixty seconds after the start-up phase.

The aim of post-heating is to reduce pollution during the minutes after start-up.

Engine water temperature	Duration of post-heating
- 30°C	3 minutes
- 10°C	3 minutes
0°C	1 minute
10°C	1 minute
18°C	30 s
40°C	0

The following parameters can interrupt post-heating:

- engine water temperature above 20°C.
- flow injected above 35 mm³,
- engine speed more than 2000 rpm.

Additional heating

Application: as per vehicle and country of sale.

In view of the high output of the engine, the rise in temperature should be assisted from the cab in case of low temperatures.

The rise in temperature can be assisted using the injection computer.

Two devices are used depending on the country of sale:

- a boiler supplied with fuel and located in the engine compartment (very cold countries),
- back-up immersion heaters (electrical resistors) located in the water circuit of the unit heater.

32 - injection computer

34 - immersion heater (electrical)

35 - boiler

Back-up immersion heaters are fitted in series on the unit heater water circuit.

The injection computer can enable the start-up of these systems depending on engine water temperature and outdoor air temperature.

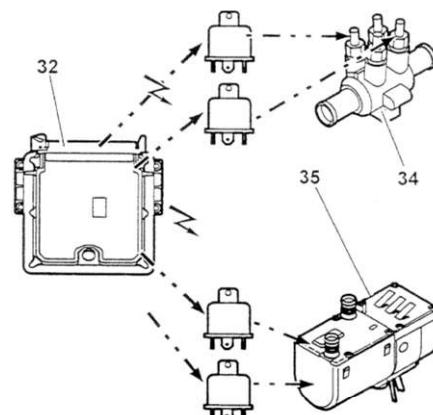

Controlling heating systems

1 – immersion heater

Two types of assembly are used as per the vehicle:

- assembly with two relays - two immersion heater units,
- assembly with three relays - three immersion heater units.

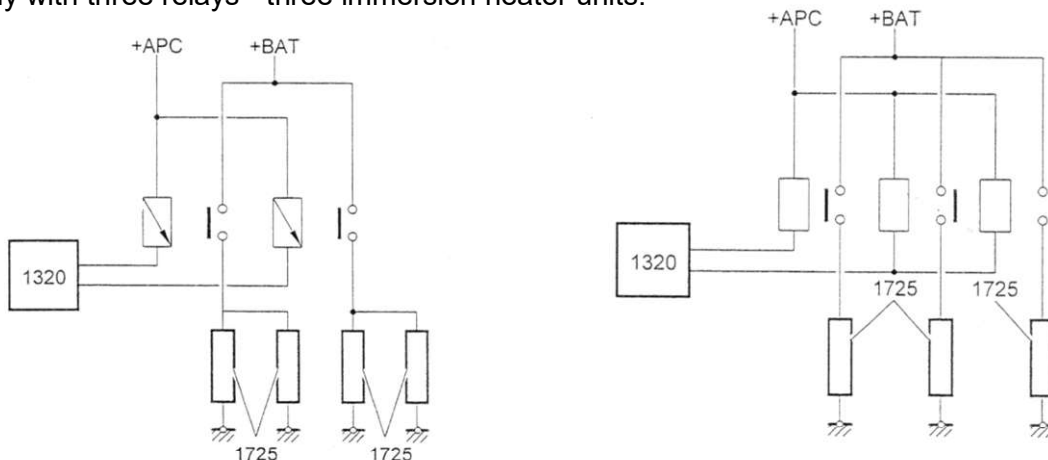

Assembly with two relays - two immersion heater units:

1320 - injection computer
1725 - immersion heaters

The immersion heaters can provide a unit power of 200 W (total: 800 W).

The assembly can provide two heating capacities: 400 W or 800 W.

Assembly with three relays - three immersion heater units:

1320 - injection computer
1725 - immersion heaters

The resistors can provide a unit power of 300 W (total: 900 W).

The assembly can provide two heating capacities: 300W or 900 W

2 - boiler

1320 - injection computer
1725 additional heater unit

Electrical cabling can only be used to obtain one single heating capacity.
Electronics built into the heater manage the boiler.

Functionalities

The boilers start up if:

- heating is required (specific curve),
- compatible with engine operating conditions.

1- determining heating requirements

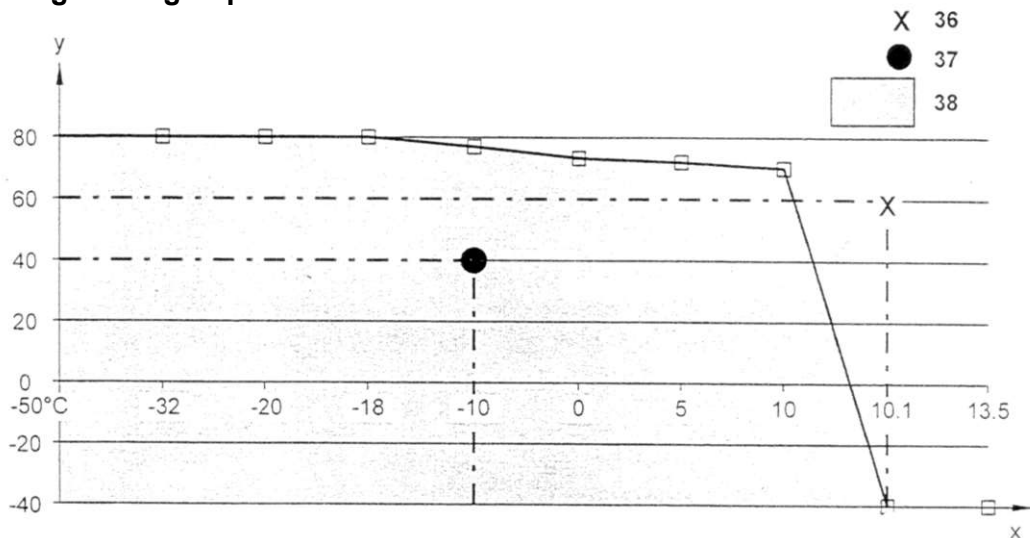

36 - example 2

38 - heating enabled zone.

x - outdoor air temperature

37 - example 1

y - engine water temperature.

The computer determines heating requirements at start-up depending on the curve.

Example 1:

- engine water temperature = 40 °C,
- outdoor temperature = -10°C,
- temperature conditions are in the start-up zone for additional heaters.

Example 2:

- engine water temperature = 40 °C,
- outdoor temperature = 10.1°C,
- temperature conditions are outside of the start-up zone: no heating.

2- operation

The computer determines if heating is required from start-up, based on the curve.

If heating is required, the computer will trigger the start-up of the heaters, if the following conditions are satisfied:

- engine operating for 60 seconds,
- engine speed > 700 rpm,
- battery voltage >12V (positive electrical output),
- engine water temperature > -40°C.

To begin with, the computer will trigger the first heating stage, and then trigger the second unit after a time delay of 20 seconds.

Heater activation will stop as soon as temperature conditions are appropriate (curve).

Cooling compressor cutout

The computer manages cooling compressor cutout.

The injection computer is connected:

- to a pressure switch stage fitted in the air conditioning circuit,
- to the engine water temperature probe.

32 - injection computer

39 - pressure switch (26-bar stage)

40 - engine water temperature probe

41 - cooling compressor cutout relay

42 - cooling compressor

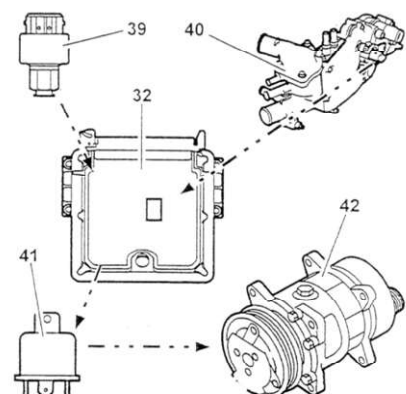

Functionalities

The computer can cut the supply of the electromagnetic clutch of the cooling compressor in the following circumstances;

- engine speed < 750 rpm,
- water temperature above 115°C,
- pressure of more than 26 bars in the air conditioning circuit.

1.4.2. Defect display - downgraded operating modes

Defect display

The engine diagnostic indicator will come on if certain defaults appear in the system.

The engine diagnostic indicator will come on if a defect is detected for the following components or items of information:

- capacitor No. 1 voltage (injector command stage in the computer),
- capacitor No. 2 voltage (injector command stage in the computer),
- high pressure fuel sensor,
- rail pressure supervision loop,
- accelerator pedal sensor (stage no. 1),
- accelerator pedal sensor (stage no. 2),
- supercharger sensor,
- air flowmeter,
- sensor supply no. 1,
- sensor supply no. 2,
- exhaust gas recycling function (control),
- supercharging solenoid control valve,
- high pressure fuel regulator,
- injector defect (1 to 4).

Downgraded modes

The system manages the following downgraded modes:

- an operating mode with reduced fuel flow,
- another operating mode leading to immediate engine shutdown.

Reduced flowrate:

The "reduced flow rate" downgraded mode limits fuel flow, therefore engine speed cannot exceed 3200 rpm in any case.

The system will switch to reduced flowrate mode if a defect is detected for one of the following components:

- high pressure fuel sensor,
- rail pressure supervision,
- accelerator pedal sensor (stage no. 1), and accelerator pedal sensor (stage no. 2),
- intake manifold pressure sensor and air flowmeter,
- vehicle speed sensor,
- exhaust gas recycling function (control),
- supercharging solenoid control valve,
- high pressure fuel regulator.

Air conditioning compressor cutout:

The computer cuts the supply to the clutch of the air conditioning compressor if a defect is detected for the command relay winding of the powered fans.

De-activator for the 3rd piston

When fuel temperature is above 106°C, the computer de-activates the 3rd piston. (De-activator supplied).

Engine shutdown:

The system will trigger the immediate shutdown of the engine if a defect is detected for one of the following components:

- eeprom in the computer,
- engine speed sensor,
- camshaft sensor,



- capacitor No. 1 voltage (injector command stage in the computer),
- capacitor No. 2 voltage (injector command stage in the computer),
- rail pressure supervision loop,
- injector defect (1 to 4).

Driver information function

Diagnostic indicator:

Normal indicator operation: the indicator comes on at ignition, and then goes out after approximately 3 seconds.

Abnormal indicator operation: the indicator comes on at ignition and stays on.

Tachometer signal:

The engine computer returns the engine speed signal to the panel in the form of voltage intervals.

Instantaneous consumption signal:

The injection computer transmits instantaneous consumption data to the vehicle computer in the form of voltage intervals.

Pre-heating indicator (V1150):

The pre-heating indicator can inform the driver of pre-heating in progress or a failure for the preheating circuit.

Operating mode during pre-heating:

- the indicator will come on during pre-heating (maximum 20 s)
- the indicator will go out at the end of pre-heating.

Water temperature warning indicator:

The water temperature warning indicator can be triggered:

- by the injection computer.
- by a 3-way probe (3-way water temperature probe).

Indicator operating mode for the two types of assembly:

- indicator comes on if the temperature exceeds: 118°C,
- the indicator goes out if the temperature falls below: 117.5°C,
- the indicator will flash if the cable to the engine water temperature probe breaks.



Peugeot wiring diagram

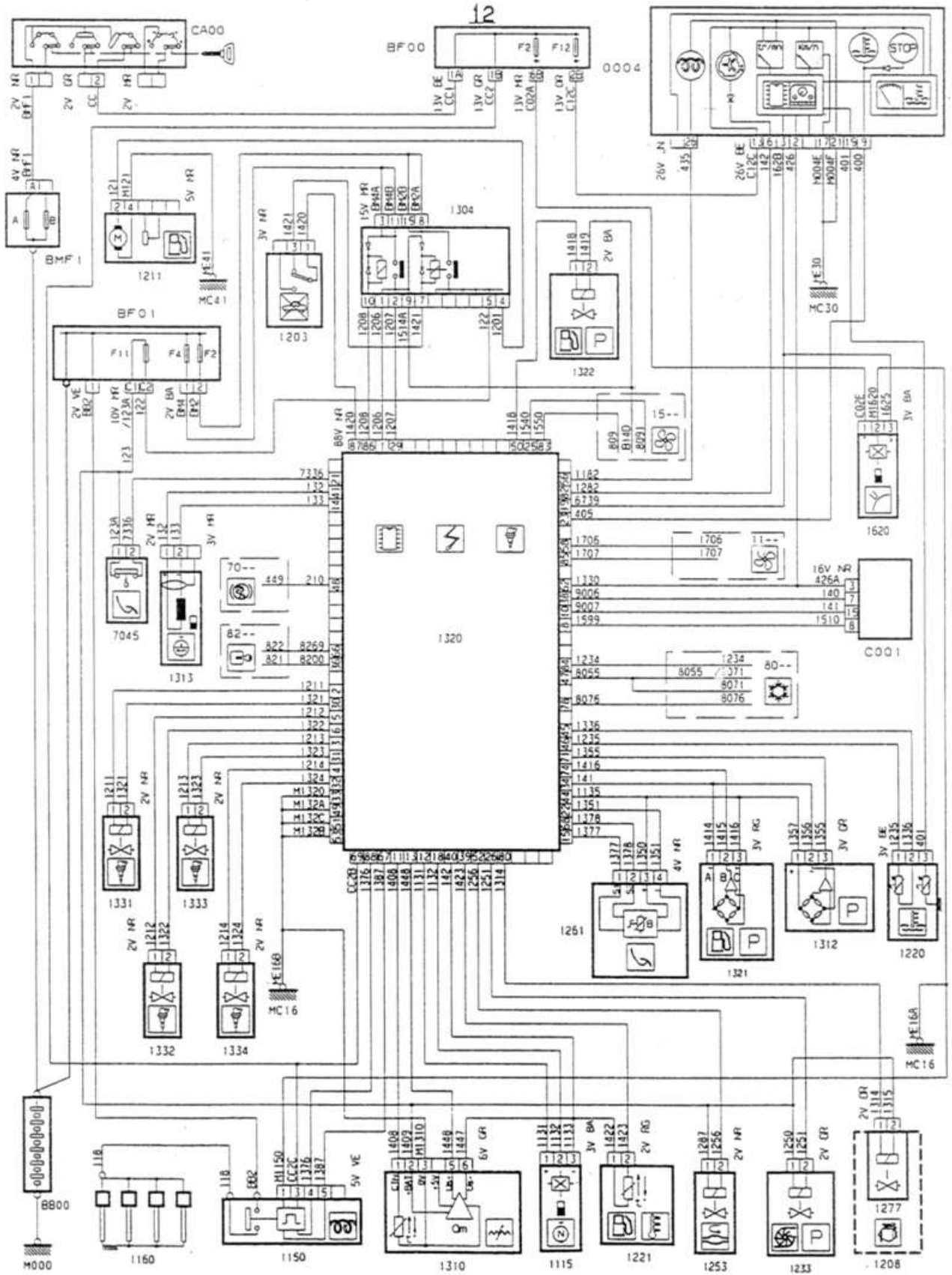

List of defect codes

Number	Description
0100	Air flowmeter (1310)
0110	Air temperature sensor (1310)
0115	Engine water temperature sensor (1220)
0121	Accelerator pedal position sensor 1 (1261)
0180	Fuel temperature sensor (1221)
0190	Diesel pressure sensor (1321)
0201	Injector 1 (1331)
0202	Injector 2 (1332)
0203	Injector 3 (1333)
0204	Injector 4 (1334)
0215	Power relay (1304)
0221	Accelerator pedal position sensor 2 (1261)
0230	Fuel pump supply (1322)
0235	Intake manifold pressure sensor (1312)
0243	Turbocompressor pressure solenoid valve (1233)
0335	Engine speed sensor (1313)
0340	Cylinder reference sensor (1115)
0380	Pre-/post- heating relay (1150)
0381	Pre-heating indicator (004) (0004)
0403	EGR solenoid valve command (1253)
0500	Vehicle speed sensor (1620)
0560	Battery voltage
0603	Computer (1320)
0606	Computer (1320)
1101	Atmospheric pressure sensor (1320)
1108	High speed powered fan command
1109	Low speed powered fan command
1110	Air conditioning cutout command
1112	Diesel high pressure supervision (1320)
1135	De-activator of the 3 rd piston of the HP pump (1208)
1138	Fuel pressure regulator (1322)
1169	Capacitor no. 1 voltage (1320)
1170	Capacitor no. 2 voltage (1320)
1171	Injector supply cutout test
1300	Pre-/post- heating relay command (1320)
1403	Additional heating 1
FFF3	Additional heating 2
1408	Engine water circuit heater
1511	Post-ignition + supply
1521	Clutch contactor (7045)
1614	Sensor supply (1320)



Defect data

Defect	Back-up functions	Indicat or ON	Associated variables
Air flowmeter (1310)	$Q_{air}=1000$ mg/injection Sensor supply in U_{bat} Reduced flow mode ($N < 3200$ rpm)	X	1 - Speed 2 - Air flow
Air temperature sensor (1310)	$T^{\circ}_{air} = 50^{\circ}C$		1 - T°_{air} 2 - T°_{water}
Water temperature sensor (1220)	While driving, $T^{\circ}_{water} = 110^{\circ}C$ At start-up, $T^{\circ}_{water} = -10^{\circ}C$ High-speed start-up of powered fans		1 - Speed 2 - T°_{water}
Accelerator pedal sensor 1 (1261)	Idle = 1200 rpm Use of signal 2. If sensor completely inoperative, α pedal = 5%	X	1 - Pedal sensor 1 2 - Pedal sensor 2 3 - Speed
Fuel temperature sensor (1221)	$T^{\circ}_{diesel} = 70^{\circ}C$		1 - T°_{water} 2- T°_{diesel}
Diesel pressure sensor (1321)	$P = 400$ bar with a low load $P = 400$ to 1000 bar if the load increases Reduced flow mode ($N < 3200$ rpm)	X	1 - Speed 2 - Regulator current 3 - Diesel pressure
Injector (1331-1332-1333-1334)	None Engine shutdown	X	1 - Speed 2- T°_{diesel}
Power relay (1304)	None		1 - Speed 2 - T°_{water} 3-U battery
Accel pedal position sensor 2 (1261)	Idle = 1200 rpm Use of signal 1. If sensor completely inoperative, α pedal = 5%	X	1 - Pedal sensor 1 2 - Pedal sensor 2 3 - Speed
Fuel pump supply	None		1 - Speed 2 - T°_{water} 3-U battery
Intake manifold pressure sensor (1312)	$P_{man} = P_{atm}$ If P_{atm} with defect, $P_{man} =$ reduced flow mode ($N < 3200$ rpm)	X	1 - Speed 2 - Air flow 3 - P_{atm}
Turbocompressor pressure solenoid valve (1233)	Reduced flow mode ($N < 3200$ rpm)	X	1 - Speed 2 - Injected flow 3 - P_{atm}
Engine speed sensor (1313)	Engine shutdown		1 - Speed 2 - Pedal sensor 3- Vehicle speed
Cylinder reference sensor (1115)	Restart impossible after recognition of the defect		1 - Speed 2 - T°_{water}
Pre-/post- heating relay (1150)	None		1 - Speed
Pre-heating indicator (0004)	None		1 - Speed 2 - T°_{water} 3-U battery
EGR electronic command (1253)	Reduced flow mode ($N < 3200$ rpm)	X	1 - Speed 2- Air flow setpoint
Vehicle speed sensor (1620)	Vehicle speed = 150 km/h		1 - Speed 2 - T°_{water} 3- Vehicle speed



Defect	Back-up functions	Indicat or ON	Associated variables
Battery voltage	None		1 - Speed 2 - T° _{air} 3-U _{battery}
Computer (1320)	Engine shutdown		
Atmospheric pressure sensor (1320)	P _{atm} = P _{man} for N < 900 rpm and fixed above 900 rpm If a defect exists for the intake manifold pressure sensor, P _{atm} = 900 mbar		1 - Speed 2 - P _{atm} 3 - P _{atm}
High and low speed powered fan command	None		1 - Speed 2 - T° _{water}
Air conditioning cutout command	None		1 - Speed 2 - T° _{water}
Diesel high pressure supervision (1320)	Reduced flow mode (N < 3200 rpm) or Engine shutdown	X	1 - Speed 2 - Diesel pressure 3 - Regulator duty cycle
De-activator of the 3 rd piston of the HP pump (1208)	None		1 - Speed 2 - T° _{water} 3 - P _{fuel}
Fuel pressure regulator (1322)	Reduced flow mode (N < 3200 rpm)	X	1 - Speed 2 - Regulator current 3 - P _{fuel}
Capacitor no. 1 and no. 2 voltage	Engine shutdown	X	1 - Speed 2-U _{battery} 3-U _{battery}
Injector supply cutout test (post-operation)	None		1 - Speed 2 - T° _{water}
Pre- and post-heating relay command	None	X	1 - Speed 2 - T° _{water} 3-U _{battery}
Additional heater no. 1 and no. 2	None		1 - T° _{water} 2 - T° _{air}
Engine water circuit heater	None		1 - T° _{water} 2 - T° _{air}
Near-ignition + supply	None		1 - Speed 2 - T° _{water}
Clutch contactor (7045)	Clutch engaged		1 - Speed 2 - Pedal position
Sensor supply (1320)	None	X	1-U _{supply} 2-U _{battery}



2. USER DOCUMENTS

2.1. INSTALLATION GUIDE AND INSTRUCTIONS

Installation and start-up of the MT-H9000 training model.

Set the ignition key to the St position, connect the model to the 230V mains supply (check the position of the power switch on the side of the MT-H9000 training model)

Then activate the control buttons (key contractor) for the operation of the system according to the instructions supplied with the MT-H9000 training model.

No moving parts exist on this MT-H9000 model.

Operational environment:

The MT-H9000 training model must be installed in a clean, dry location, free of dust, water vapour and combustion fumes. The equipment requires a lighting level of approx. 400 to 500 Lux. The equipment can be installed in a Practical Workshop Classroom, the noise generated will not exceed 70 dBA. The MT-H9000 training model is protected against any errors by future users.

Calibration and servicing of the MT-H9000 training model:

Calibration: Factory Settings.

Servicing interval: N/A

Cleaning: Use a soft, clean cloth with a window cleaning product.

Number of stations, user position:

The MT-H9000 training model is considered as one single workstation.

Training bench users will remain stood up throughout the practical work.

Method for removal from service:

Set the ignition key to the St position.

Remove the 220V connection.

Check for current by setting the ignition key to the Start position. If nothing happens, no current is present.

Remove the ignition key, and place in a locked cupboard.

Check that the rear cover is in position.

Then store the MT-H9000 training model in a closed room with a front panel marked 'Equipment Removed from Service'.

Residual hazards:

Only monitors can access the rear area.

Trainees will spend the entire period of practical works on the front part of the training model.

!!! Only qualified and authorised members of personnel may access the interior of the bench!!!

Transporting the MT-H9000 training model:

The model must be turned off and removed from service before transport (see instructions on removal from service). Important: never leave anything on the tablets.

At least two people are required (wearing safety shoes and protection gloves).

Use the carry handles fitted for this purpose.



2.2. HI-TEC BATTERY CHARGER

HI-TEC 50 W-100 W HIGH FREQUENCY BATTERY CHARGERS

User manual and installation guide for all models with 1 and 2 outputs.

12 V version: 12V/ 4A – 12V/ 8A

24V version: 24V/ 2.5A – 24V/ 5A

48V version: 48V/ 1.25A – 48V/ 2.5A

Technical specifications

Input voltage 230 V \approx -15%/ +10%

50/60 Hz frequency

Output voltage U_{bat} +/- 2%

Output current I_{bat} +/- 10%

Tropicalisation of electronics

Natural ventilation

Connecting cables – batteries and mains - : 1.80 metres

Operating temperature -10/ +45 °C

Storage temperature -20°C/ +70 °C

Relative humidity 90%

Protection rating IP 235

User safety: EN 60335-1 and EN 60335-2-29

EC certified: EN 50081-1, EN 50082-1 and EN 55011 class B,

EN 60555-2, EN 60555-3

Description of the HI-TEC charger

The technological benefits of high frequency;

Compact, light chargers;

Invariable charging quality, regardless of disturbance to input supply (generator, mains supply).

The HI-TEC charger, developed in close cooperation with battery manufacturers, is configured at the factory to suit your application: the charge curve will be ideally suitable for all battery technologies (as preferred: liquid electrolytes, gel electrolyte, lead-calcium, etc.).

A 3-state type charge curve is integrated to maintain the life cycle and initial capacity of your batteries:

BOOST/ quick charge: charging to maximum capacity in the shortest possible period.

ABSORPTION / equalising: top up to maximum charge by gradually reducing the charge intensity.

FLOATING / maintenance charge: compensate for permanent consumption by maintaining an optimal battery charge.

Unique on the market, the HI-TEC system can be used to permanently connect and use the battery, while maintaining a real BOOST voltage (high voltage) for a short period. The charger will automatically switch to maintenance charge.

Battery information

Marine batteries.

Battery manufacturers have achieved significant progress in recent times and created a whole new generation of batteries: maintenance-free batteries. The batteries are easy to use, however this process requires a complex charging technique and strict precision.

Each battery is designed to use specific technology and therefore requires a specific load curve. Remember to indicate the type of your batteries before purchase.

Safety instructions

Batteries can release gas in the event of significant overcharging. The mixture released (oxygen and hydrogen) can be explosive. HI-TEC eliminates this hazard by limiting any overcharging.

Deep discharge is one of the main causes of premature wear for batteries. This risk is limited by using a HI-TEC during maintenance.

After a discharge (particularly if the discharge is above 50%), you are not recommended to store batteries as they are (charge at the earliest opportunity).

Low and permanent overcharging is another cause of premature wear, HI-TEC batteries only provide the current required to charge the battery and only provide the end-of-charge current required.



Accidental and brutal overspeed or excessive intensities at end-of-load will lead to premature destruction due to an excessive increase in temperature. Battery temperature must never exceed 50°C. HI-TEC protects the battery against overheating at end-of-load thanks to current control.

IMPORTANT. For safety purposes, it is essential to unplug the charger from the mains and we recommend that you disconnect the batteries before carrying out any operation inside the charger.

MANUFACTURER RECOMMENDATION: do not open the cover.

Installation.

Installation.

The charger can generally be installed horizontally or vertically. In marine environments, where water run-off is frequent, we recommend installing the charger vertically. Leave a clear area of approx. 15 cm around the pack. This will optimise system cooling by air flow. Provide for: one low cold air inlet and one high hot air vent.

Connecting the batteries:

Connect the positive battery terminal to the red wire and the negative terminal to the black wire. Repeat for battery no. 2 (the negative cables for the batteries are wired together).

Table of battery fuses:

Type of HI-TEC	Glass slow blow fuse, 5 x 20 mm
24V/ 2.5A – 48V / 1.25A – 48V/ 2.5A	2.5A
12V/ 4A – 24V / 5A	6.3A
12V / 8A	10A

IMPORTANT. Check the fastening of the battery cables on the battery (a significant risk of heating exists if the cables are not correctly tightened).

Connecting to the mains.

The charger is designed to operate from a mains supply with a nominal rating of 230 VAC – 50Hz/60Hz as standard or 115 VAC upon request.

The charger automatically switches to the right mains position at power-up.

Display.

Charger operation is indicated by each LED as follows:

Red "Def." LED: reverse polarity

Yellow" Charge" LED: this LED will light up if the battery is not completely charged.

Green "100%" LED: this LED will light up when the battery is charged.

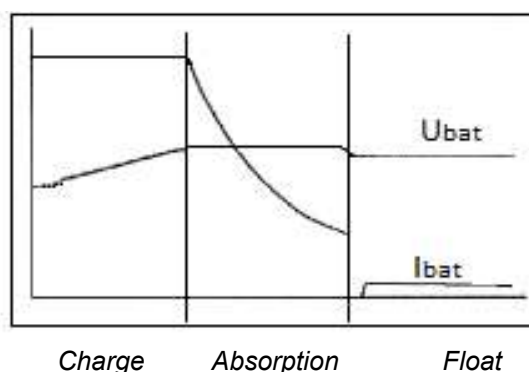
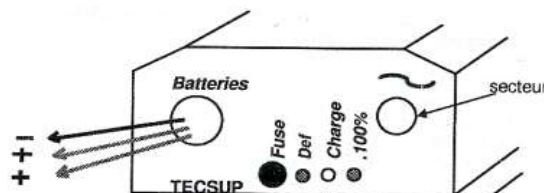

Charge current:

The nominal current announced corresponds to the mean current provided by the charger and can be used permanently.

Safety.

Electronic protection against:

- Output short circuits,
- Battery discharge in the event of a mains power cut.

Fuse protection against:

- Overload at mains inlet,
- Reversed battery polarity (external fuse).

Anti-corrosion:

- Aluminium pack with rustproof paint.

Anti-impact:

- Impact resistance during routine use thanks to the 2 mm thick pack.

Options

Mains supply 115V.

Specific output current and input voltage upon request, subject to the power limits of the model.

Options must be ordered and will be assembled at the plant.

TECSUP chargers benefit from a top-of-the-range definition thanks to all of the above. Their production technology makes the difference.



2.3. MODEL DESCRIPTION

230V wiring diagram:

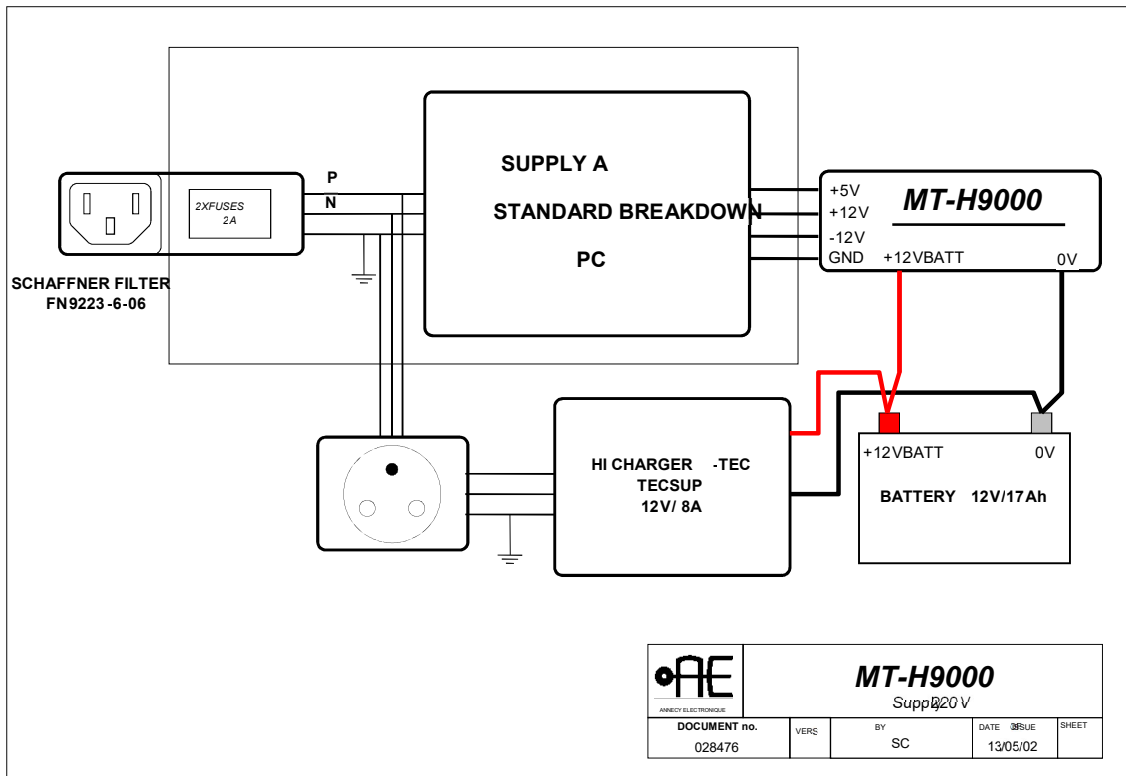

Access to the rear panel of the model:



The MT-H9000 training model consists of 3 plates

2.3.1. Engine plate

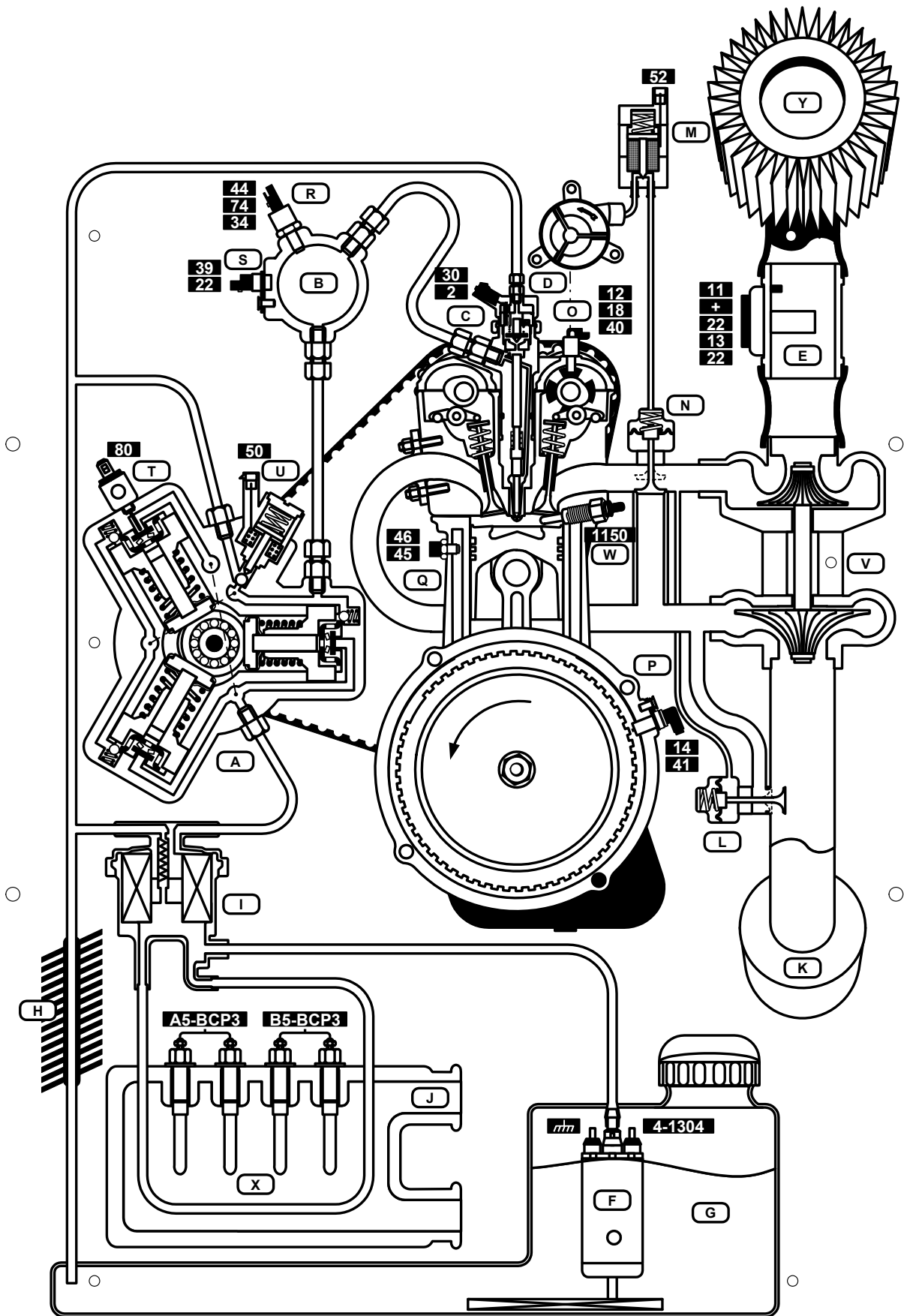

Engine plate summary table

ID	Description
2	Control signal
11	Air flowmeter signal
12	+5 v / + ref.
13	Air flowmeter signal
14	Engine speed signal
18	Sensor signal
22	Analogue ground
30	Control signal
34	Analogue ground
39	Fuel temperature probe signal
40	Analogue ground
41	Engine speed signal
44	+ 5 / + ref.
45	Analogue ground
46	Water temperature probe signal
50	Duty cycle control via the ground
52	Duty cycle control
74	Pressure sensor signal
80	Duty cycle control via the ground
1150	Pre- and post-heater spark plug control
4-1304	Supply via double relay 1304
A5-BCP3	Controls 1 st unit of 2 immersion heaters
B5-BCP3	Controls 2 nd unit of 2 immersion heaters
A	High pressure pump
B	High pressure injection rail
C	Injectors (1331, 1332, 1333 and 1334).
D	Vacuum pump
E	Air flowmeter 1310
F	Feed pump 1211
G	Diesel tank
H	Fuel cooler
I	Fuel filter
J	Additional heater 1725
K	Exhaust silencer
L	Supercharging pressure control valve
M	Recycling control valve 1253
N	Exhaust gas recycling valve
O	Camshaft sensor 1115
P	Speed sensor 1313
Q	Engine water temperature probe 1220
R	High pressure fuel sensor 1321 on the high pressure injection rail.
S	Fuel temperature probe 1221
T	De-activator for the 3 rd piston 1208
U	High pressure fuel regulator 1322
V	Turbocompressor
W	Pre- and post-heater spark plus controlled by panel 1150
X	Immersion heater BCP3
Y	Air filter

2.3.2. Control plate

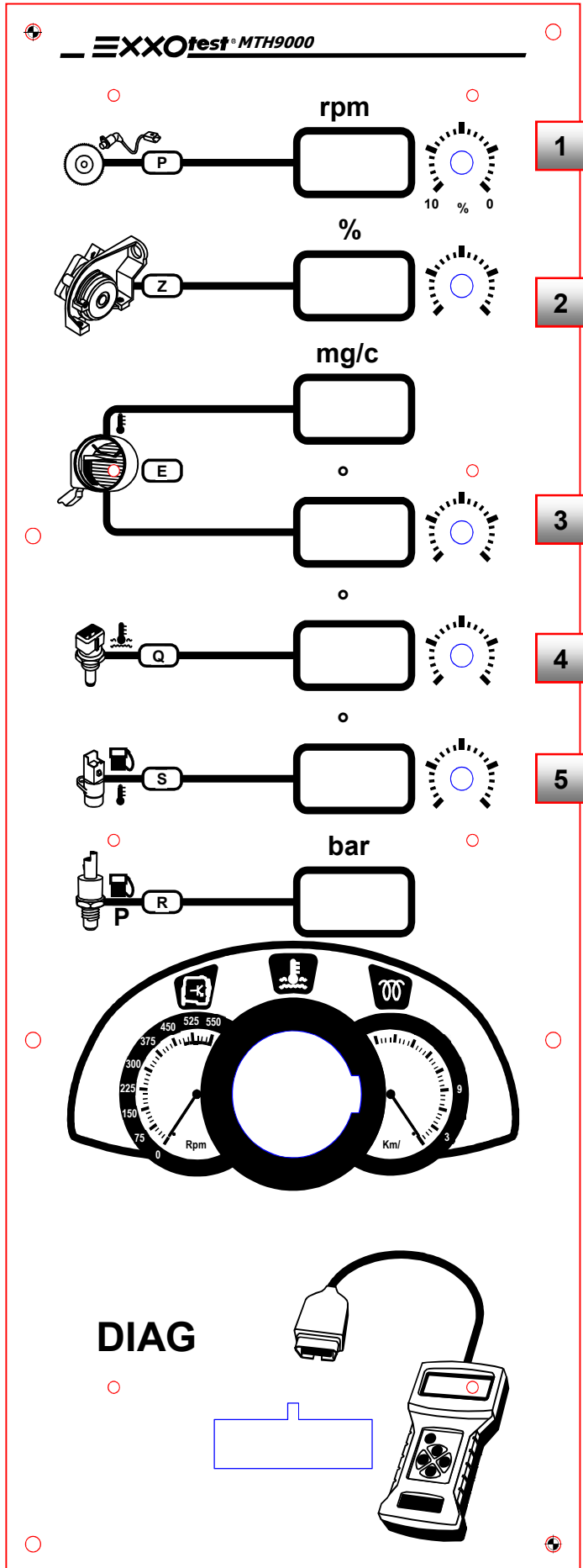





Explanatory table

ID	Description
P	Speed sensor 1313 in rpm
Z	Accelerator pedal position sensor displayed in % (1261)
E	Air flowmeter, display in mg (air milligram)/c (injection/engine cycle) and air temperature in °C 1310
Q	Engine water temperature probe 1220
S	Diesel temperature probe 1221
R	High pressure fuel sensor 1321
DIAG	Plug to connect a diagnostic device

Potentiometers

No.	Description
1	0% = normal engine speed, no load. Action on the potentiometer = reduced engine rotation speed (simulated charge).
2	Variation of the accelerator pedal (driver input)
3	Variation in air temperature
4	Variation in water temperature
5	Variation in diesel temperature

Identifiers

ID	Description
	'ENGINE DEFECT' dashboard indicator
	Engine water temperature dashboard indicator >118°C
	'PREHEATING' mode dashboard indicator
	Switch location (NEIMAN)
	Location of the 16-way diagnostic plug.

2.3.3. Computer plate

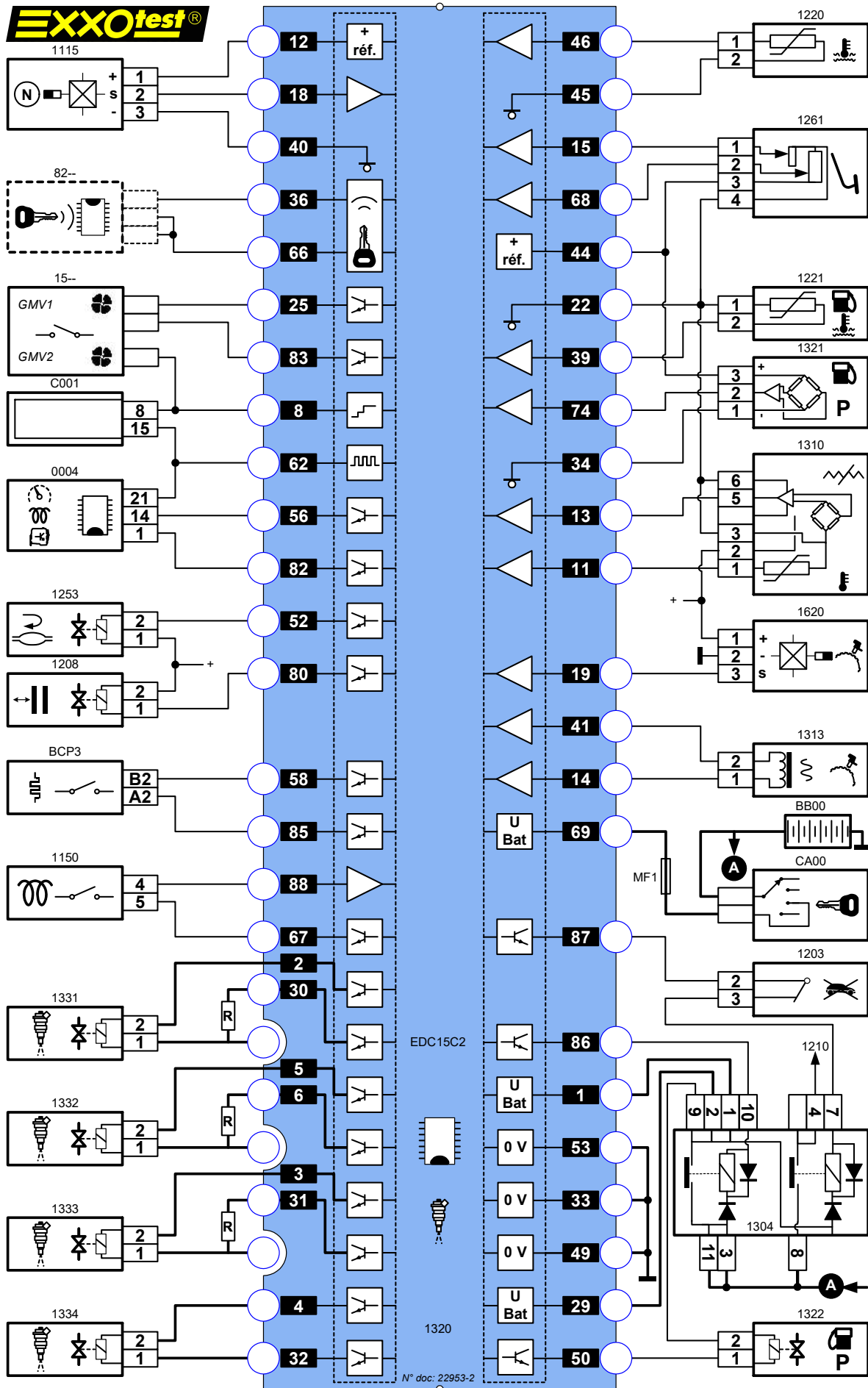

Explanatory table

Computer terminal	Description	Measurement
1	Supply + 12V (after double relay)	+12V after the double relay control via terminal 86 of the computer with + APC or the engine running
2	Injector control 1	No measurements taken
3	Injector control 3	No measurements taken
4	Injector control output 4	See curve 2
5	Injector control 2	No measurements taken
6	Injector control output 2	See curve 1
8	Powered fan control relay winding diagnostic line.	Permanent U bat, no return data from the powered fan unit
11	Air temperature probe inlet (flowmeter)	Variable voltage, at -24°C = 4.30V at 72°C = 0.6V
12	Output + ref. = + reference + 5V	+5 V with +APC or the engine running
13	Air flow signal input (flowmeter)	Variable voltage Idle = 450 mg/c = 2.5 V 3500 rpm = 630mg/c = 4 V
14	Speed sensor signal input	Sinusoidal signal 60-2 teeth, negative see curve 3
15	Accelerator pedal sensor signal input	Variable voltage U1 from 0.4 to 3.9V See curve 4
18	Camshaft sensor signal input	Hall effect sensor signals See curve 5
19	Vehicle speed input (vehicle speed sensor)	Periodic signal, see curve 6
22	Analogue ground	0V ground
25	Powered fan 1 low speed command output	Active at 0 if water T°>98°C
29	Supply + 12V (after double relay)	+12V after the double relay control via terminal 86 of the computer
30	Injector control output 1	See curve 1
31	injector 3 command output	See curve 1
32	Injector control output 4	See curve 2
33	0V ground	0V ground
34	Analogue ground	0V ground
36	Immobiliser system series line	-
39	Fuel temperature probe inlet	Variable voltage, at -23°C = 4.6V at 110°C = 0.1V
40	Analogue ground	0V ground
41	Engine speed sensor signal input	Sinusoidal signal 60-2 teeth, positive, see curve 3
44	Output + ref. = + reference + 5V	+5V with +APC or the engine running
45	Engine water temperature probe analogue ground	0V ground
46	Water temperature probe inlet	Variable voltage, at -23°C = 4.69V at 120°C = 0.19V
49	Ground	0V ground
50	High pressure fuel regulator command output	Duty cycle, see curve 7
52	Duty cycle command output of the recycling solenoid control valve	Duty cycle, See curve 8
53	0V ground	0V ground
56	Pre-heating indicator command output	Active indicator at 1



Computer terminal	Description	Measurement
58	Command output for the 1st immersion heater unit for additional heating	Active at 0
62	Panel engine speed digital signal output	Squared signal, see curve 9
66	Wake-up injection computer wake-up input for A.D.C.	-
67	Command issued by the pre- and post-heater	Spark plugs active in state 1
68	Accelerator pedal track signal input 2	Variable voltage $U_2=U_1/2$ See curve 4
69	+APC + post-ignition	+12V with +APC or the engine running
74	Fuel pressure sensor inlet	Variable voltage, idle = 300 bar = 1.3 V at 4500 rpm = 1350 bar = 4.2 V
80	Command output for the de-activation of the 3rd piston of the high pressure fuel pump.	moving piston = Ubat inactive piston = 0 V
82	Diagnostic indicator ground command output	Active at 0
83	Powered fan 2 high speed command output	Active at 0 if water $T^>110^{\circ}\text{C}$
85	Additional heating command for the 2nd immersion heater unit	Active at 0
86	Double relay command output	Active at 0
87	Double relay command output	Active at 0
88	Transfer of pre- and post-heating relay operation	0 V when the spark plugs are controlled (terminal 67 to 1) U bat, uncontrolled spark plugs (terminal 67 to 0)

2.3.4. Measuring examples

CURVE 1.

The electrical circuits of injectors 1, 2 and 3 are directly integrated in a 1 Ohm resistor fitted in series on the MT-H9000 bench.

On this basis, the image of the current can be viewed directly for these 3 injectors.

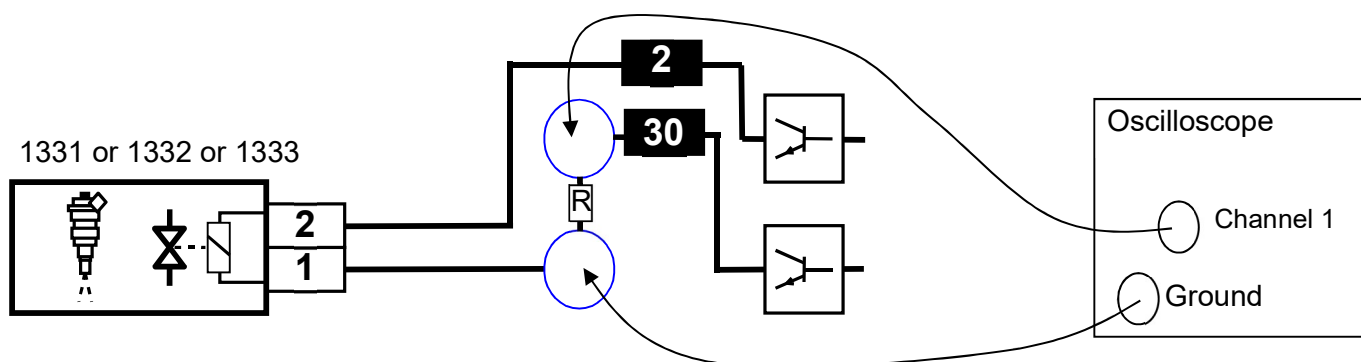

Viewing using the oscilloscope:

Pre-injection and main injection

Capacitor charge

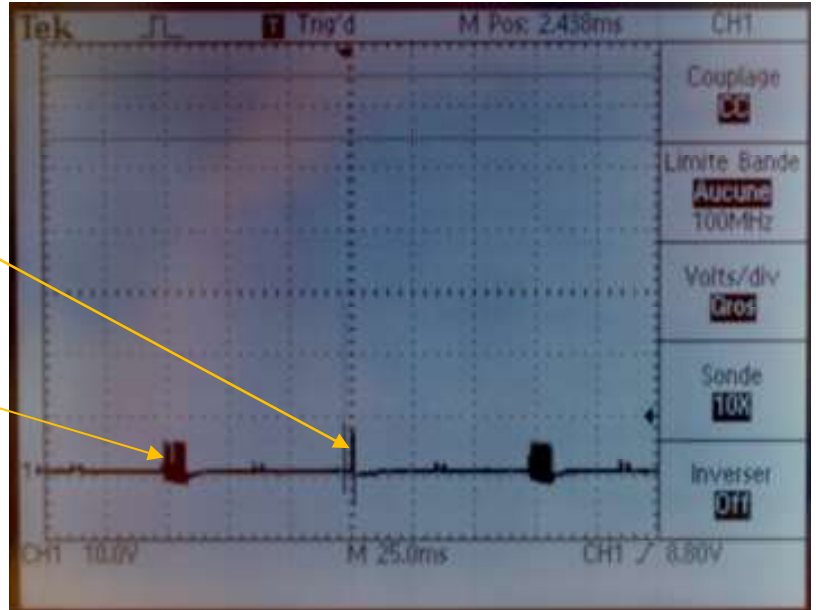

Pre-injection and main injection

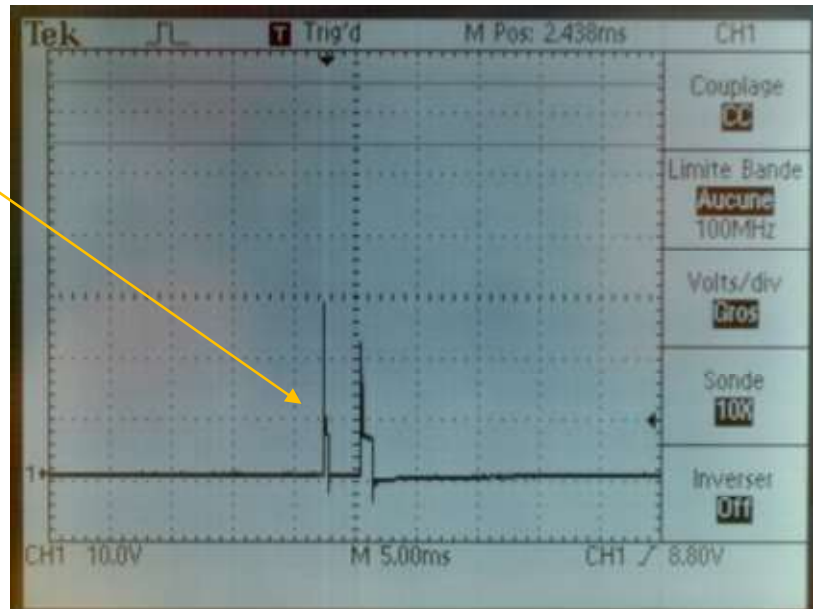

Main injection

Pre-injection

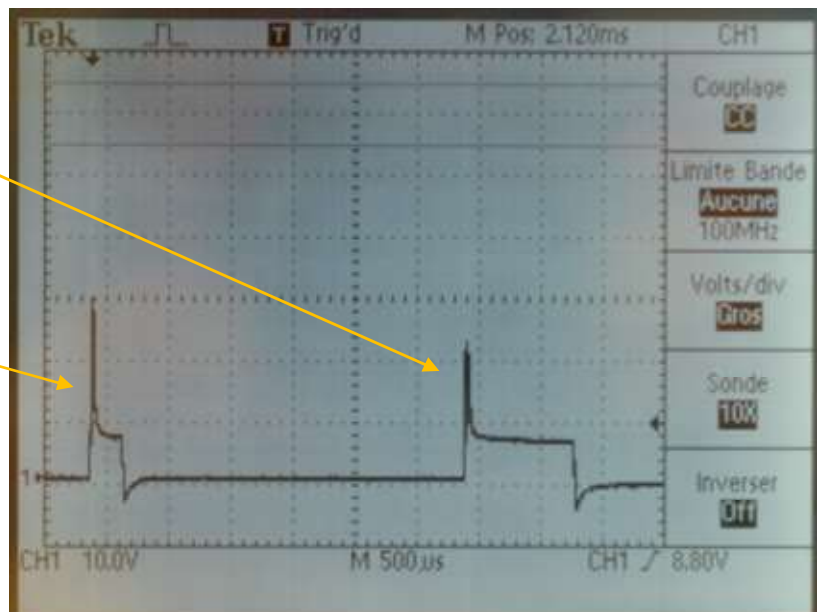

Pre-injection details:

**R = 1 Ohm.
Initial I = 30 A
Maintenance I = 8 A**

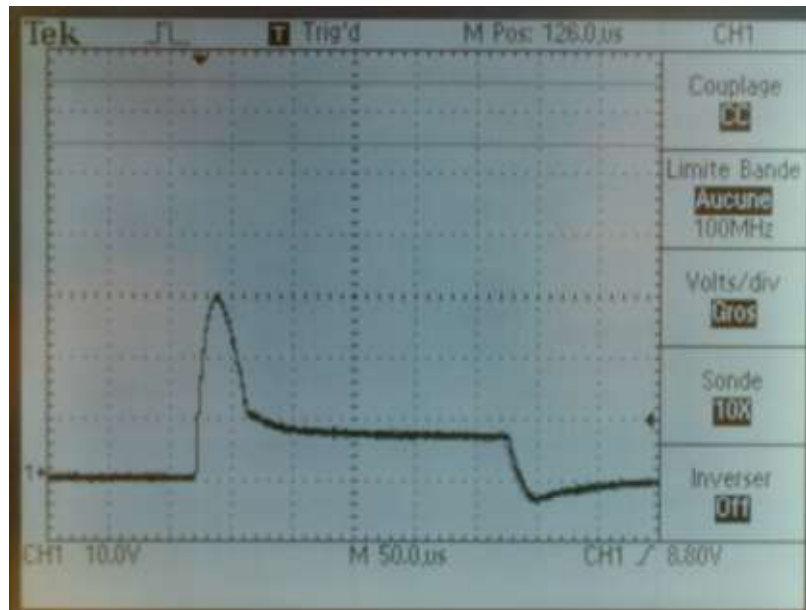

Main injection details:

**R = 1 Ohm.
Initial I = 24 A
Maintenance I = 8 A**

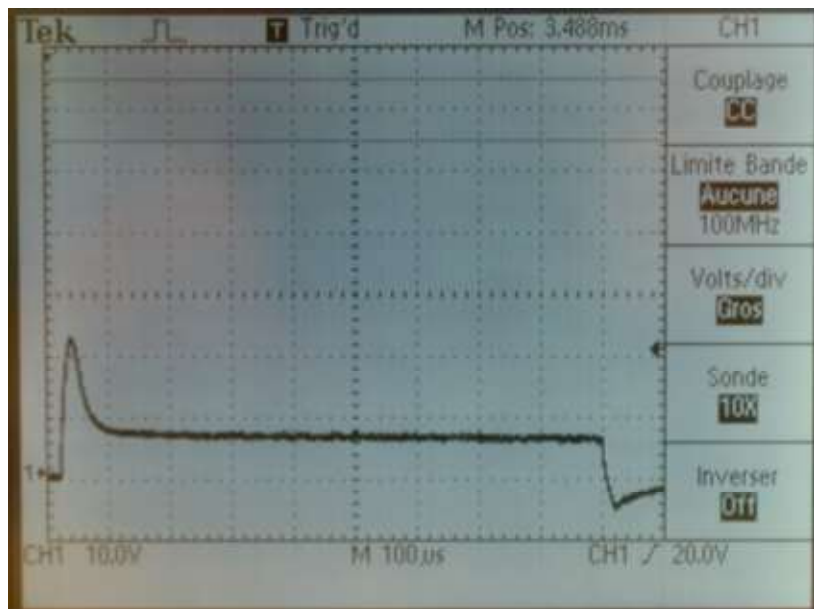

Details of capacitor charge:

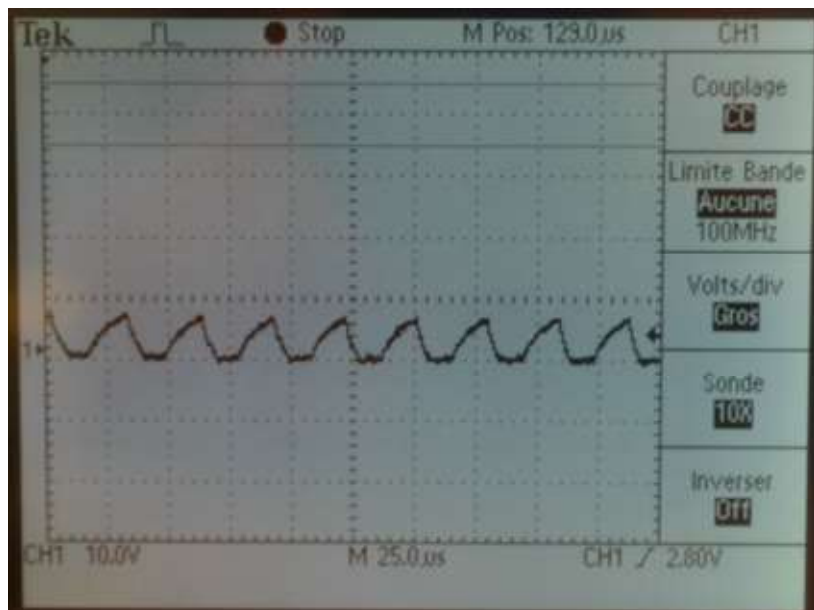

CURVE 2.

Injector 4 is wired in the same way as on the vehicle. On this basis, voltage can be viewed directly for this injector.

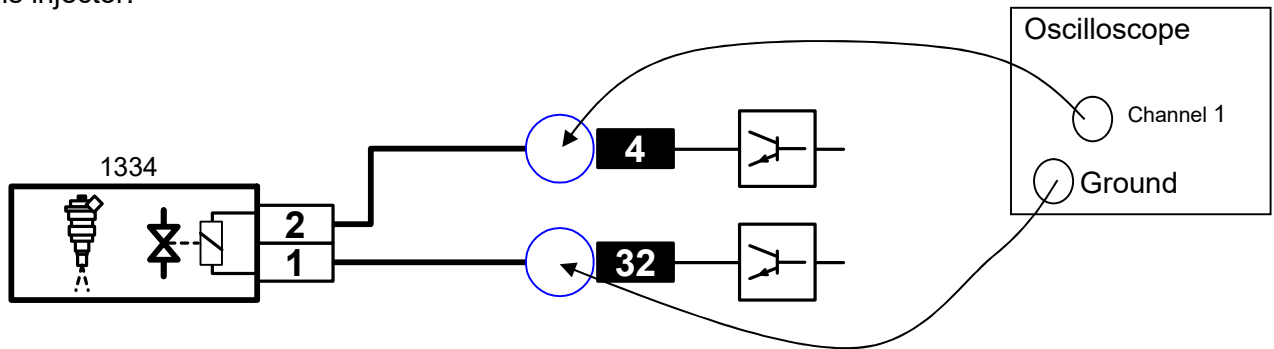

Viewing using the oscilloscope:

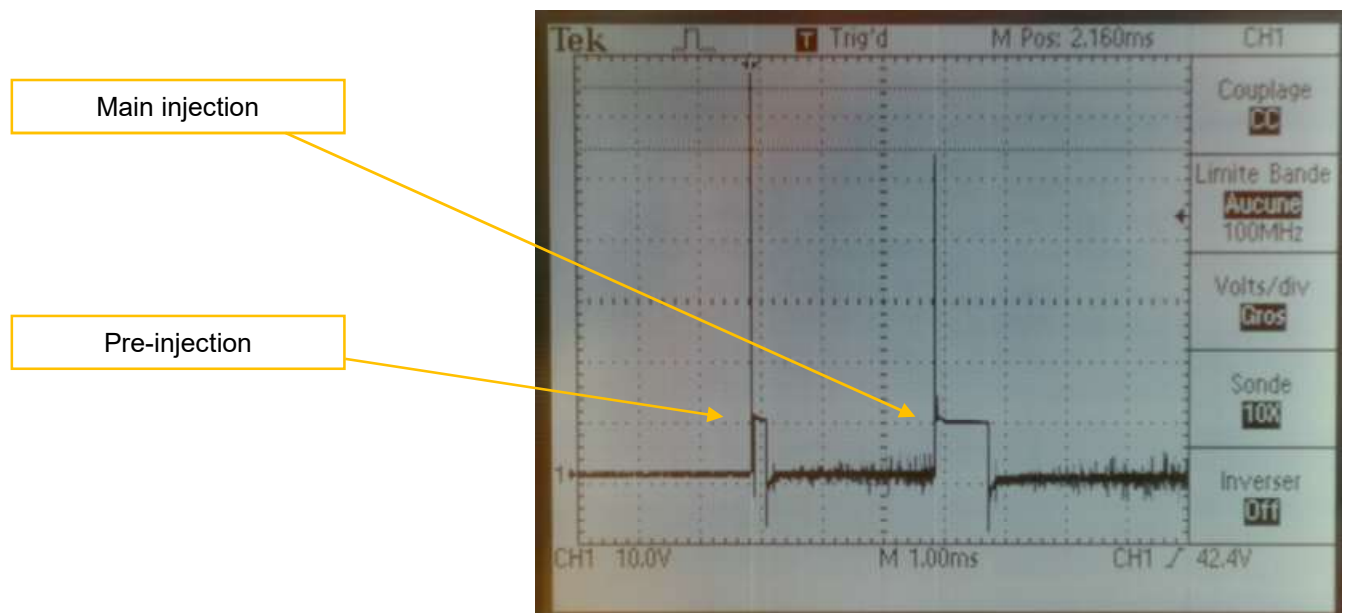
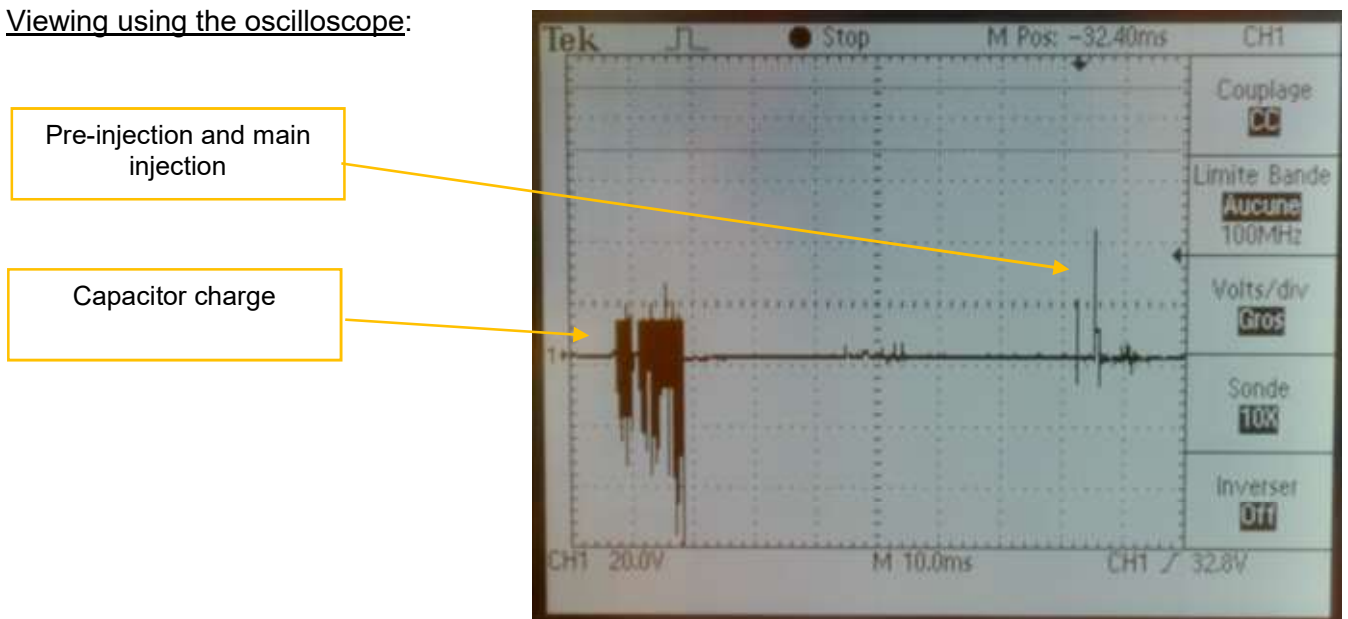

Pre-injection details:

**78 Volts to lift the needle.
Then approx. 12 volts for maintenance.**

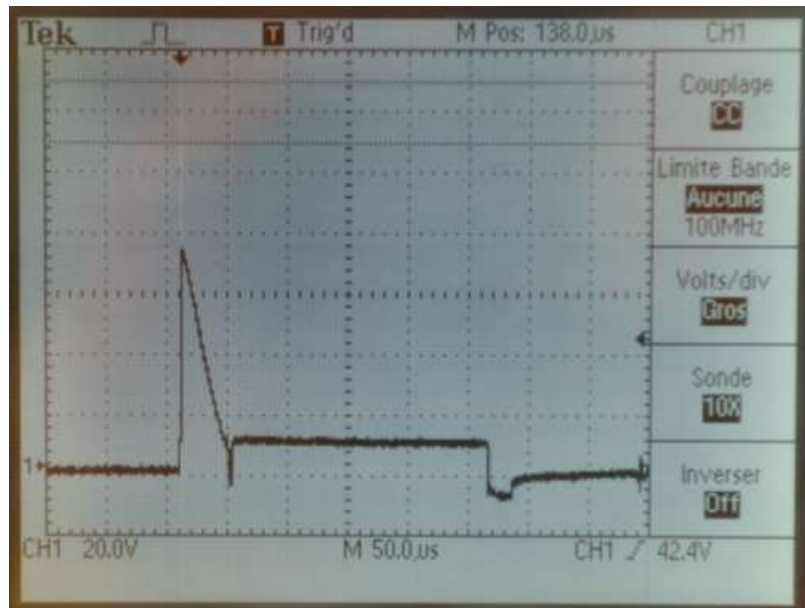

Main injection details:

**78 Volts to lift the needle.
Then approx. 12 volts for maintenance.**

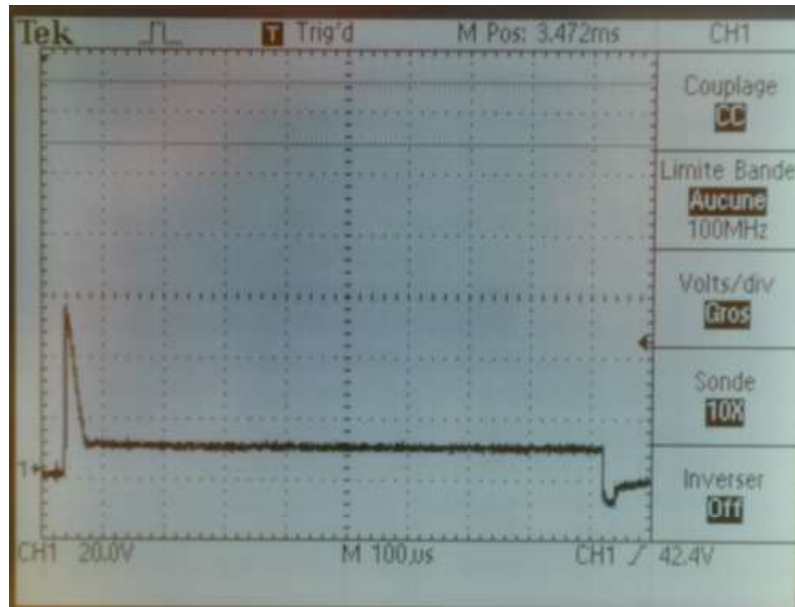

Capacitor charge with repeated 12 volts supply

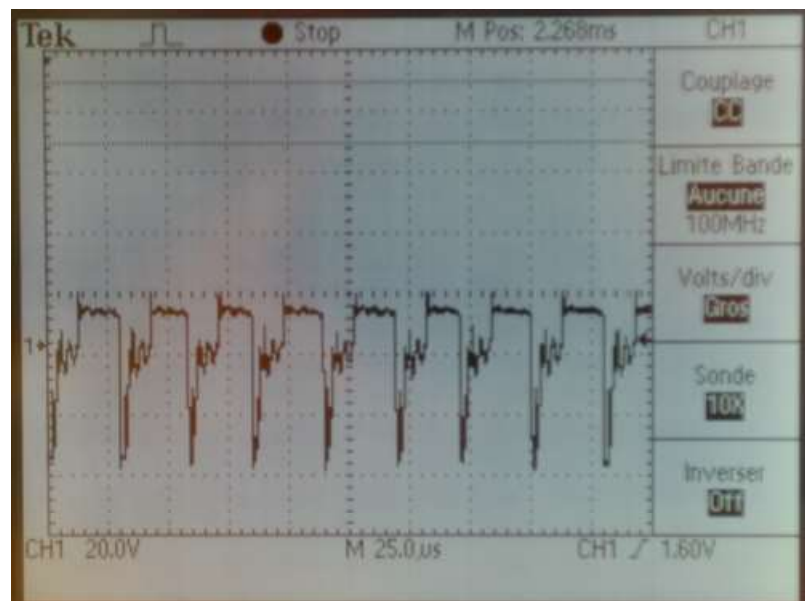

CURVE 3.

Top dead centre sensor signal input at terminals 41 or 14

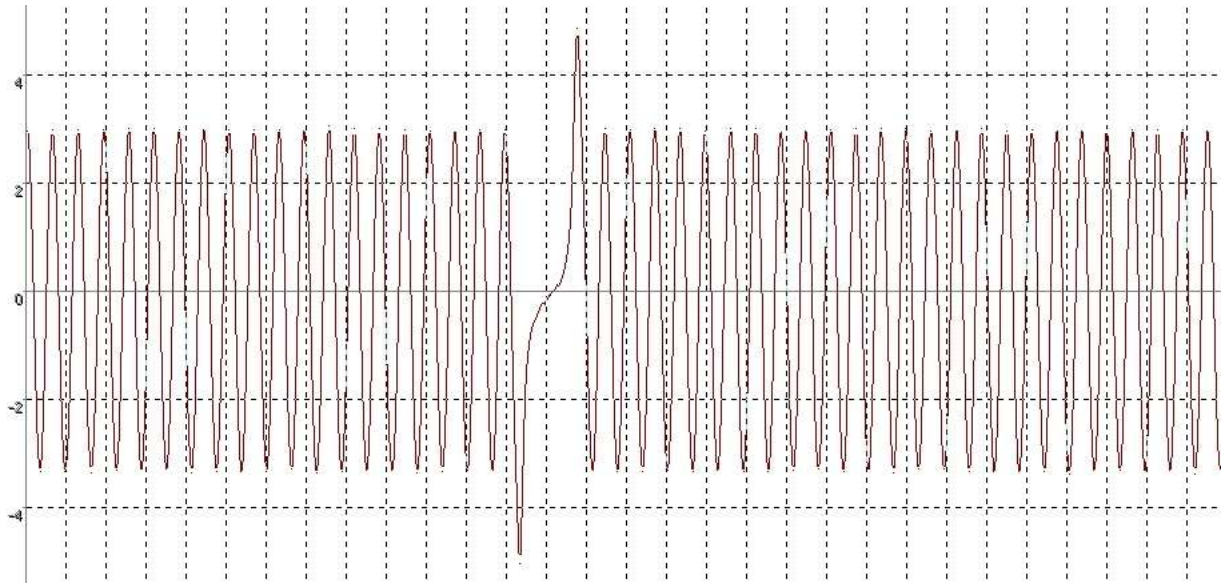

CURVE 4.

Signal inputs for the two accelerator potentiometer tracks at terminals 15 and 68

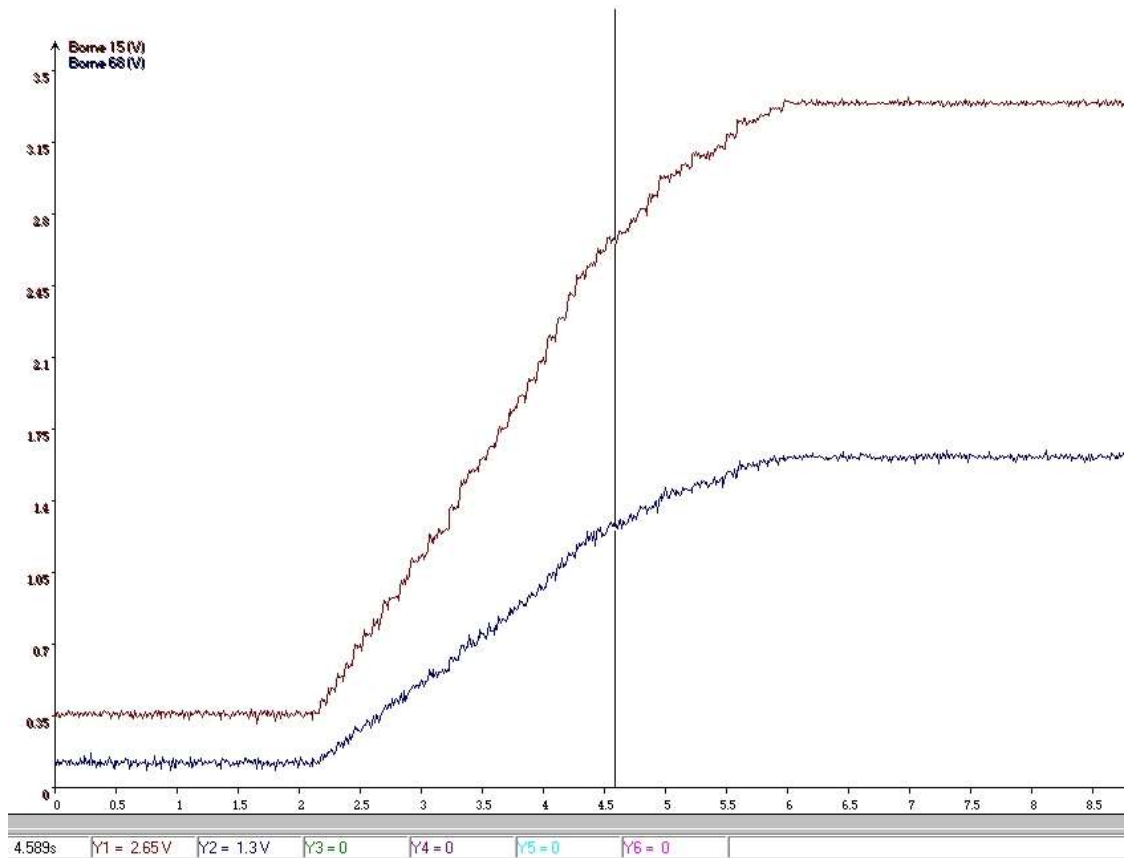

U1 U2 = U1 / 2

CURVE 5.

Camshaft position Hall effect sensor signal input at terminal 18

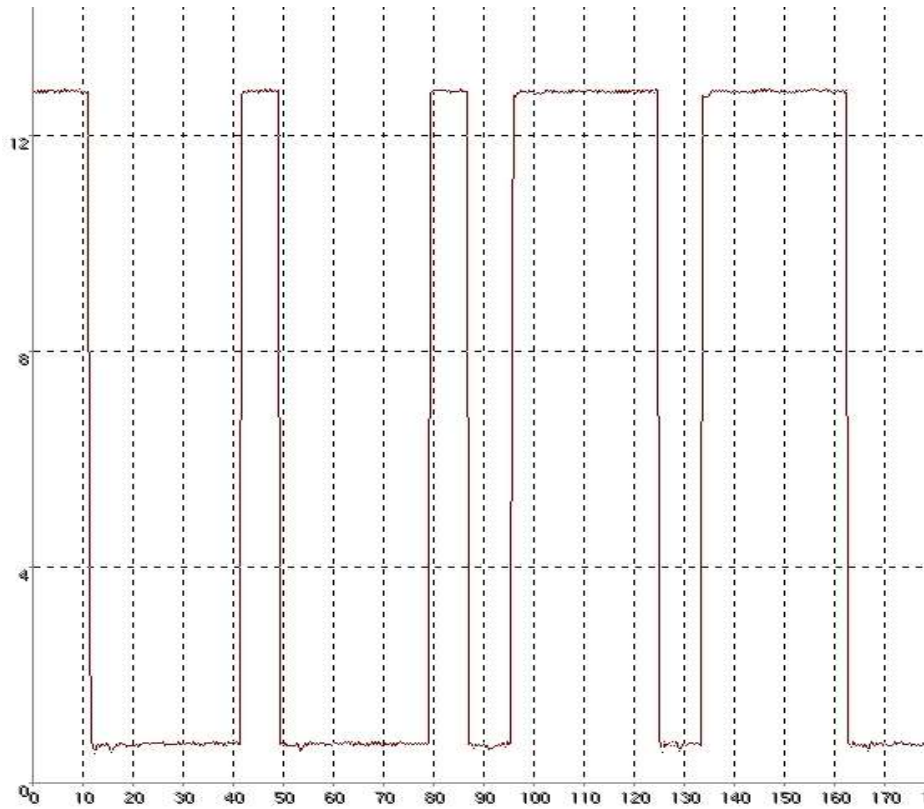
**CURVE 6.**

Vehicle speed sensor signal input at terminal 19

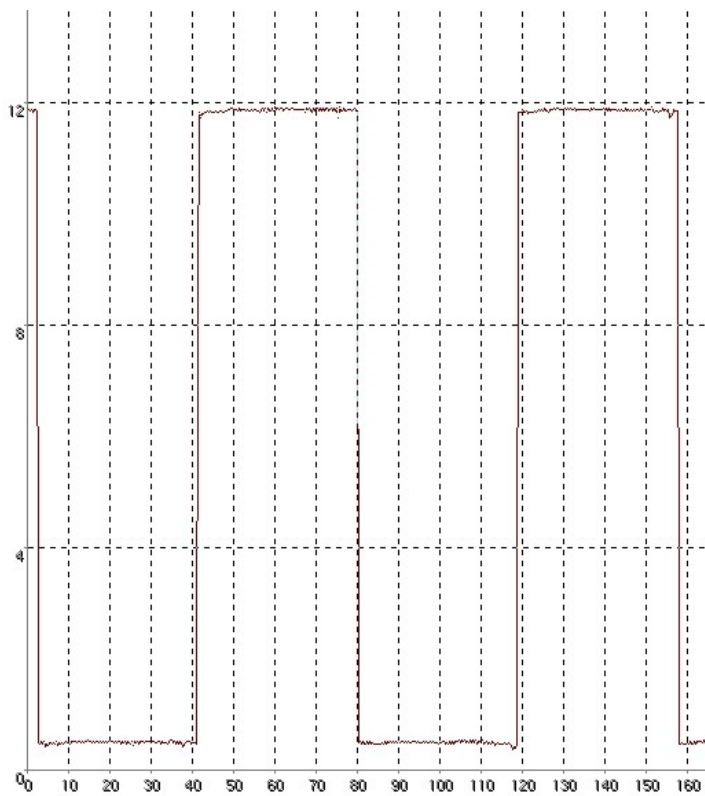

CURVE 7.

High pressure fuel regulator command signal output at terminal 50

When idle

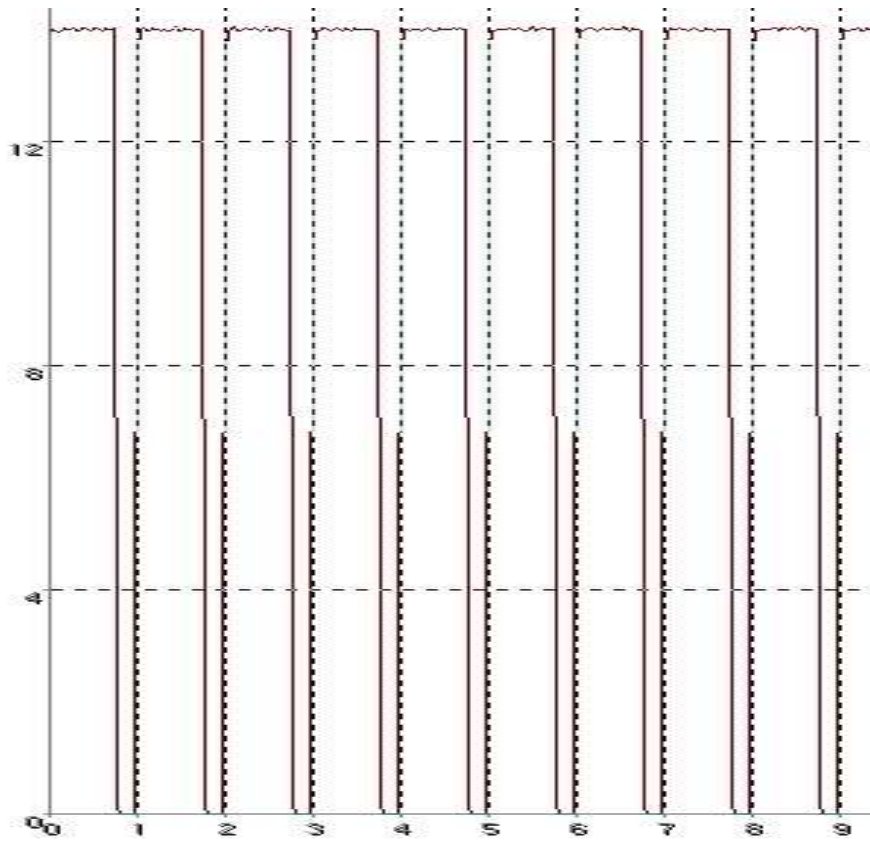

at 3300 rpm

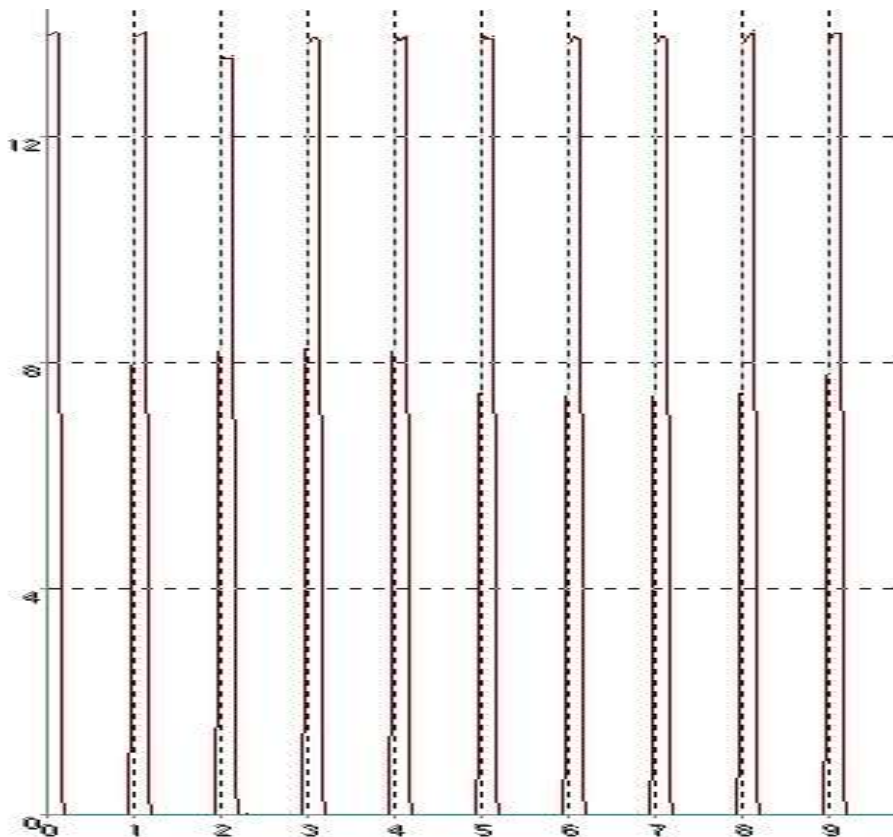

CURVE 8.

Exhaust gas recycling valve command output at terminal 52

Valve closed

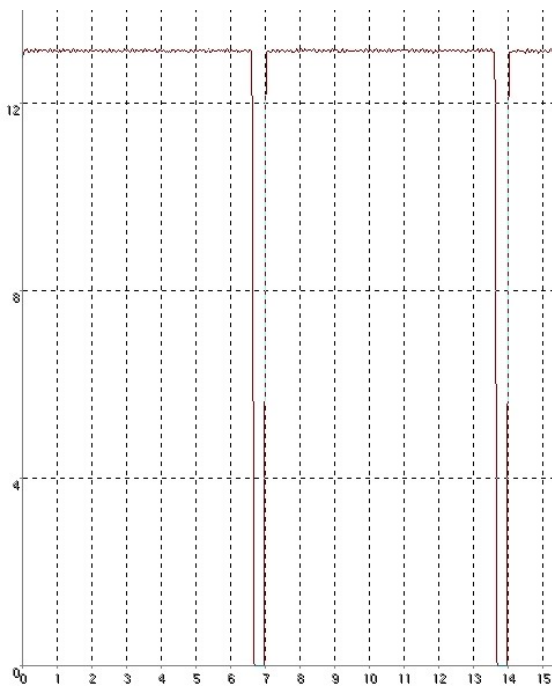

Valve open

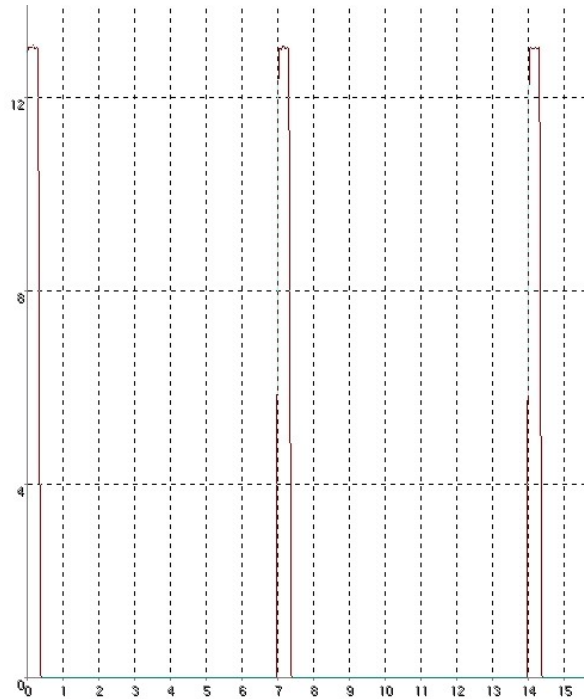

CURVE 9: panel engine speed command output at terminal 62

at 1020 rpm

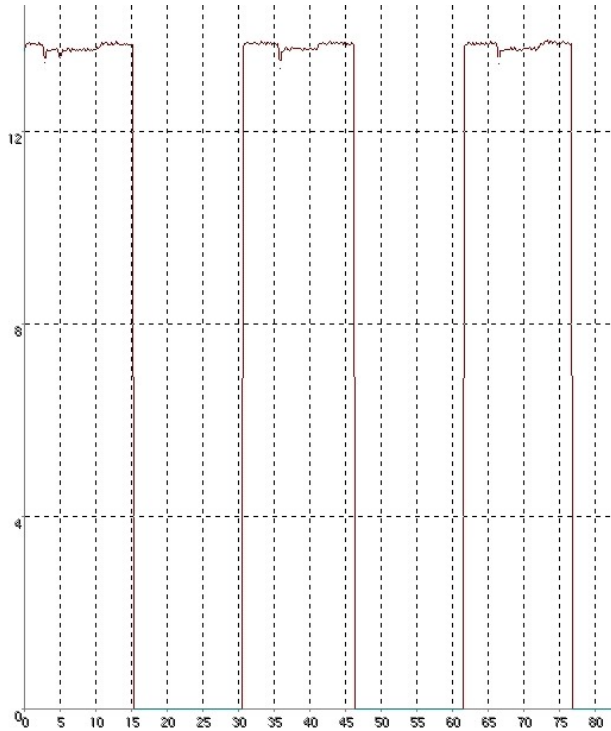

at 3240 rpm

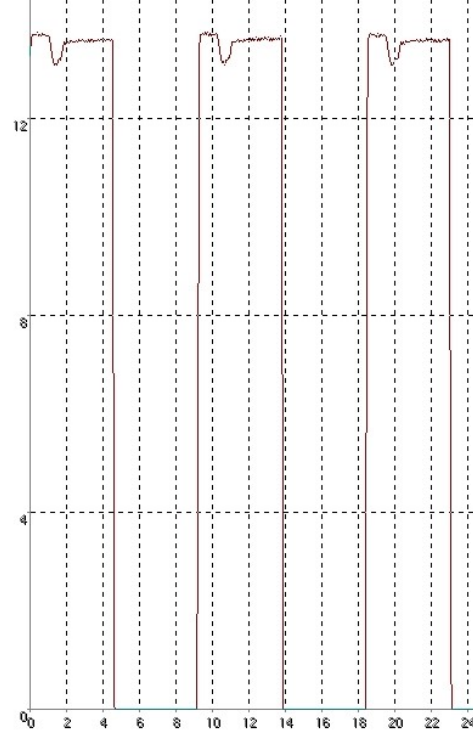

INJECTION COMMAND STUDY

Characteristics of the injection

Armature opening and closing time:	200 - 250 μ s
Needle opening time (maximum lift):	300 - 600 μ s
Initial current:	> 20A max. for 300 μ s
Maintenance current:	> 12A max. for 4000 μ s
Control volume size:	100 mm ³
Closing piston (injector needle)	
Length	78 mm
Diameter	4.3 mm
Injection holes in the injector:	6 x 0.15 mm ²
Distance between the pilot injection and the main injection: (end to start)	1 ms
Pressure interval:	120 - 1350 bars
Reaction time:	
Between the start of the command and the start of the injection	approx. 300 μ s
Between the end of the command and the end of the injection	approx. 500 μ s
Outer diameter:	17, 19 and 21 mm

Pre-injection:

Aim: Reduce the noise emitted by the combustion chamber, hydrocarbon emissions and consumption.
 Consequences of pre-injection: Pre-conditioning of the combustion chamber for the main injection in terms of pressure and temperature.

- Reduced inflammation time for the main injection
- Improved results in terms of noise (reduced rise in pressure for combustion)
- Optimal combustion

Pre-injection requirements:

- No influence on the main injection
- Slight offset from the main injection.
- Amount of fuel: as low as possible and reproducible (1 to 2% of the main injection flow with full load).

Application of pre-injection:

- Early pre-injections increase combustion noise
- Excessive pre-injections increase emission levels for particles

Ideal scenario:

- The pre-injection scenario is reduced
- Offset from the main injection increases while engine speed increases.

Main injection

Aims: Creation of high torque, modest fuel consumption, low exhaust gas emissions and minimal noise.

Requirements:

- Precise adjustment of injection timing and the flow injected
- Optimised duration of injection
- Sound distribution and spraying of the fuel in the combustion chamber.

3. TRAINING DOCUMENTS

3.1. Identify the sensors and actuators

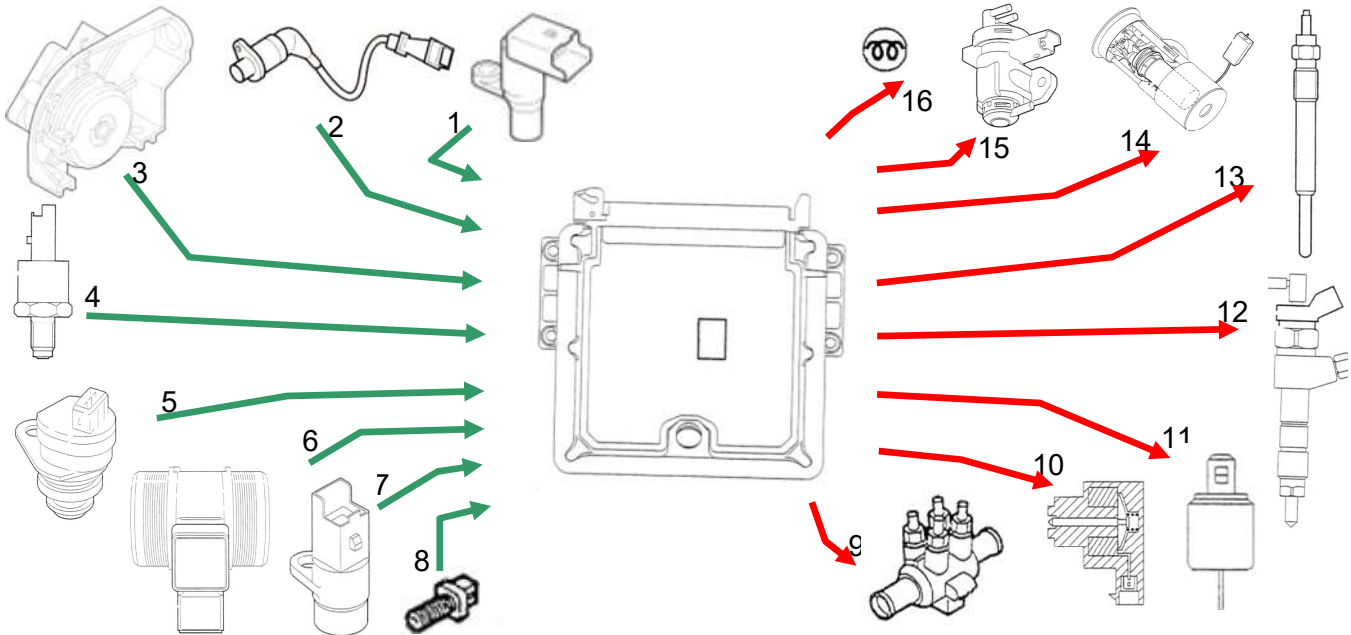



Fill out the following table and write the corresponding names next to each number.

No. 1		No. 2	
No. 3		No. 4	
No. 5		No. 6	
No. 7		No. 8	
No. 9		No. 10	
No. 11		No. 12	
No. 13		No. 14	
No. 15		No. 16	

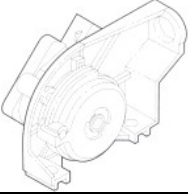

Write down the exact name, type (inductive/Hall effect, etc.) and draw the signal curve transmitted to the computer on the basis of parameters (temperature, speed, pressure, etc.) for each of the following sensors:

Sensor	Name	Type
		
Curve		
		
Curve		
		
Curve		

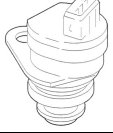
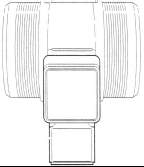
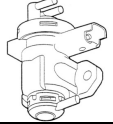
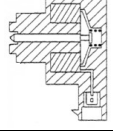
Sensor	Name	Type
		
Curve		
		
Curve		
		
Curve		
		
Curve		

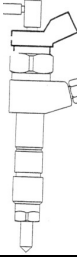

Sensor	Name	Type
		
Curve		
		
Curve		

3.2. Study of the diesel supply circuit

Indicate the route and direction of diesel flow

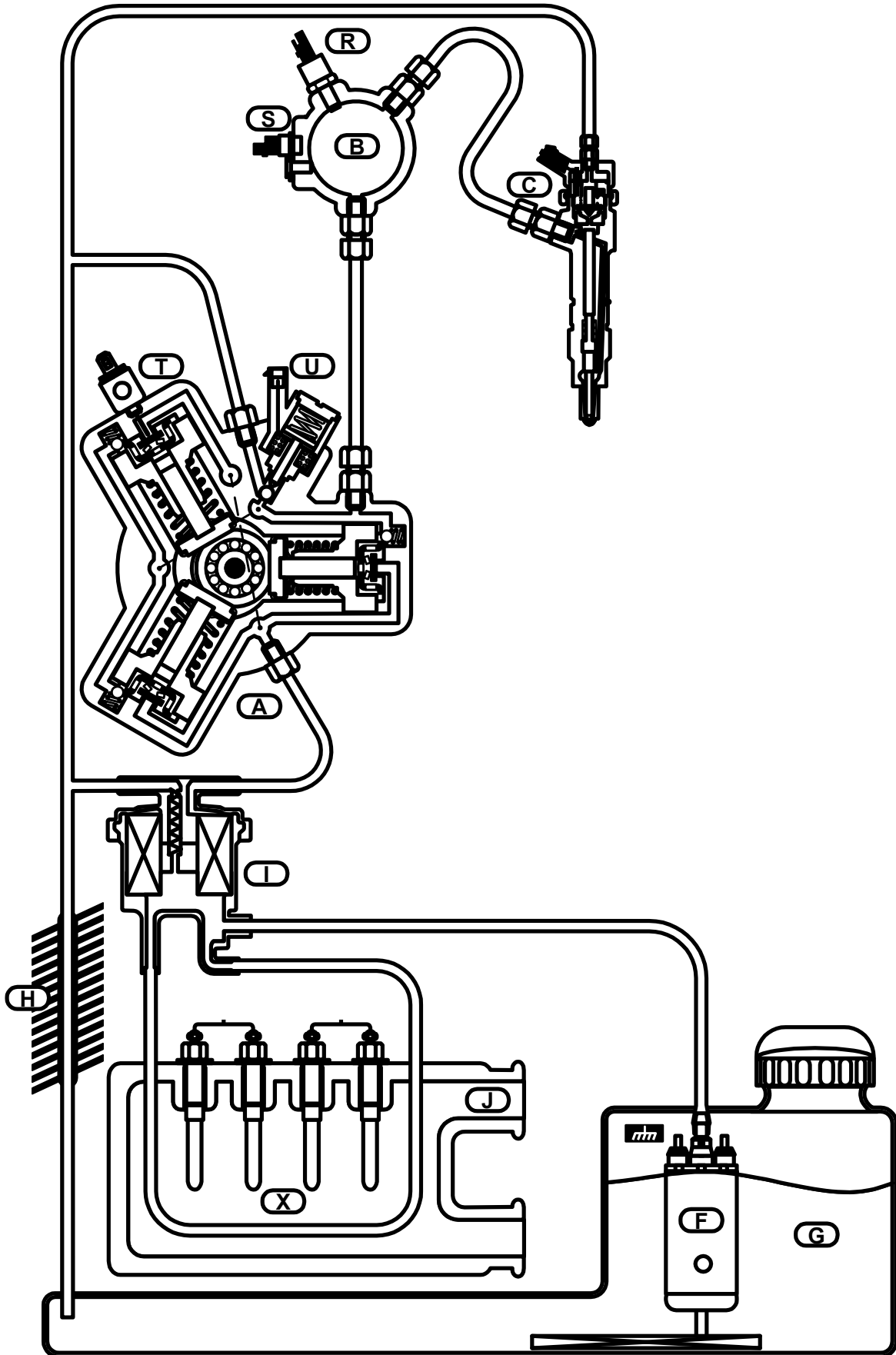

3.3. Study of the air supply circuit

Indicate the route and direction of air flow

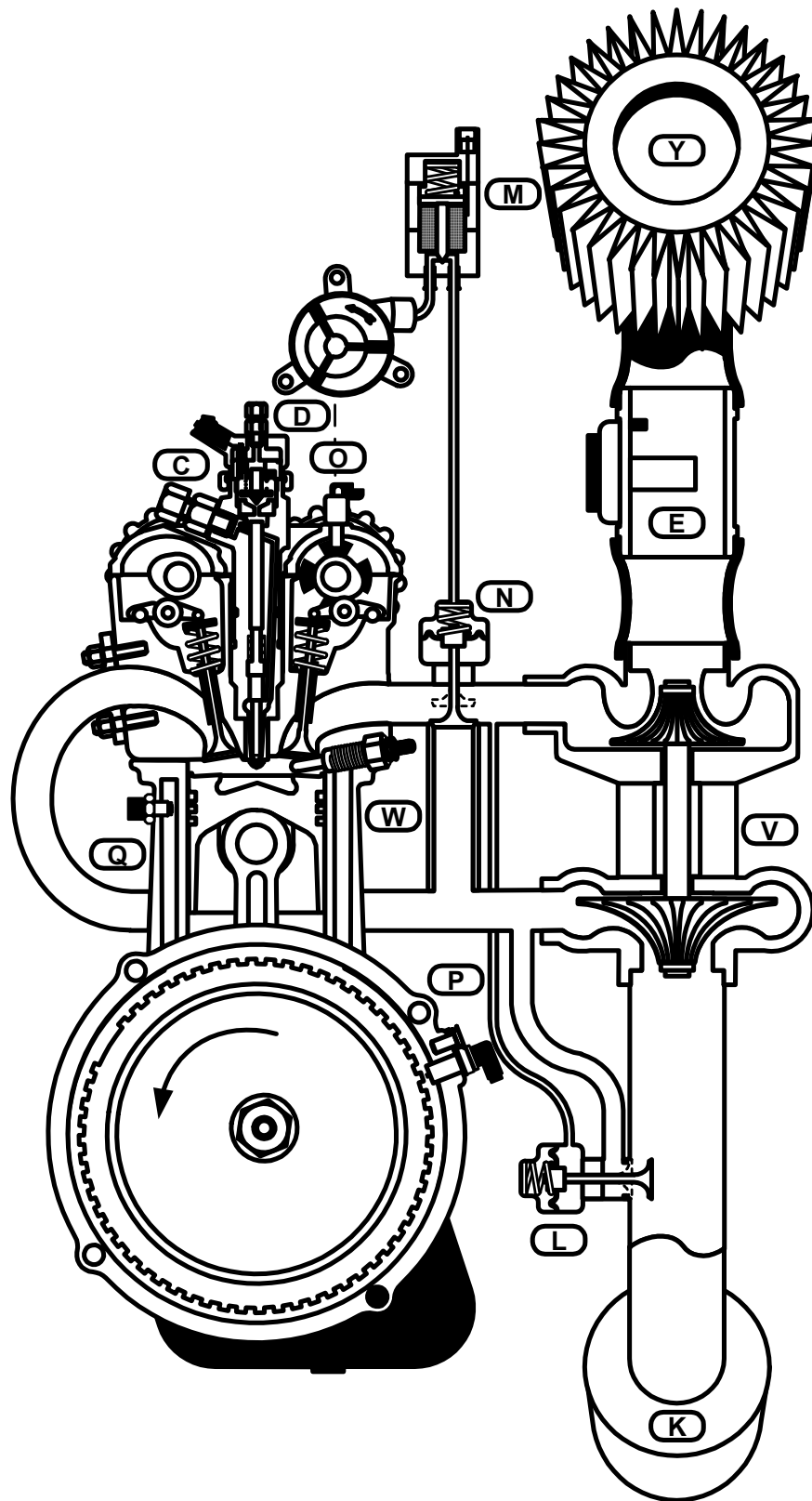

3.4. Study of system operation

Just like with any injection system, it is necessary to identify driver input (accelerator pedal position) and the amount of air entering the engine, and the amount of fuel must be adapted (diesel fuel flow) and the injection timing corrected.

The HDI system adopts the traditional architecture of petrol electronic injection systems:

- Sensors inform the computer of system status.
- The computer determines control characteristics on the basis of the maps and strategies in its memory,
- Actuators transform these commands into flow, timing and pressure, recycling, etc.

In this system, diesel flow depends on injection timing, but also on rail pressure, which can be modified. This flow can therefore be configured on the basis of three characteristics: Flow, Diesel pressure and timing.

Study of the different functions fulfilled by the system:

Determine the components

Functions	Components involved
Managing air quantity	<i>Air filter Turbocompressor Air-air heat exchanger Waste-gate valve</i>
Supply the injectors with diesel and modulate pressure	<i>Fuel tank Feed pump Thermostat Heater Low pressure regulator Cooler High pressure pump De-activator for the 3rd piston Rail Injector</i>
Measuring engine parameters	<i>Flywheel sensor Camshaft sensor Engine water temperature sensor Air temperature sensor Flowmeter Diesel pressure sensor</i>
Measuring vehicle parameters	<i>Accelerator pedal sensor Vehicle speed sensor Brake contactor Redundant brake contactor Clutch contactor</i>
Limiting pollution	<i>Pre- and post-heater Pre- and post-heater spark plugs Exhaust gas recycling solenoid valve EGR valve</i>
Managing engine cooling	<i>Water temperature indicator Warning indicator Powered fans and control of these fans Air conditioning compressor</i>



3.5. Injector control

The injector control circuit is specific.

The computer will emit an "Initial injection" type command in order to obtain the shortest possible response time (approx. 800 μ s). This phase will last for 300 μ s with a voltage of 80 V and a current of approx. 20A.

This will be followed by a maintenance phase with a voltage of 12.5V and a current of 12 A.

Electronic injector control:

Between two injections, the capacitor will be charged by an intermittent current creating back emf (due to the winding) which is directed to the capacitor.

This voltage will reach 80V. These short pulses will not open the injector.

Charging the capacitor with short current pulses in the injector.

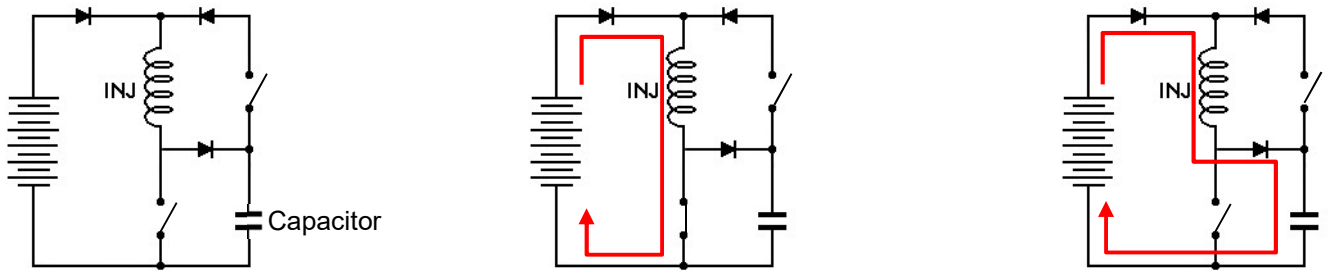

During injections, the capacitor discharges a short-term voltage of 80V into the winding, rapidly establishing a high current and therefore opening the valve rapidly.

Controlling the injector with a current spike with a fast leading edge.

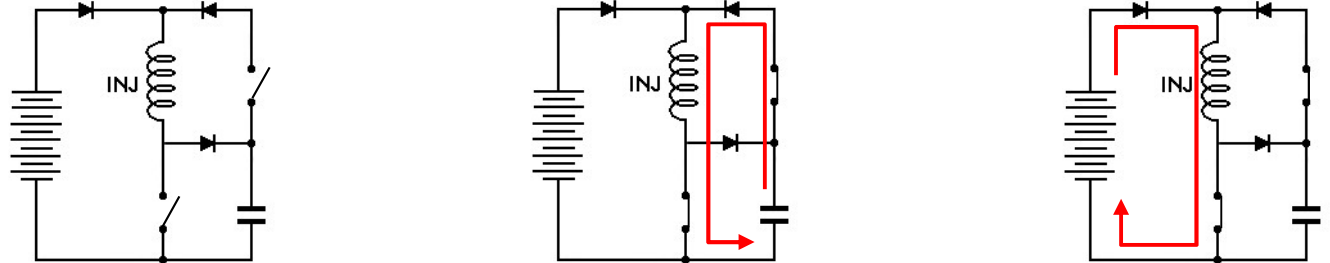

Maintaining current in the injector (with control)

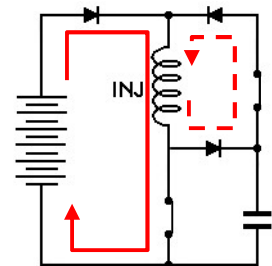

Quick interruption of the current in the injector

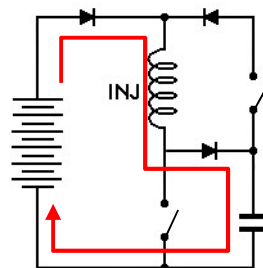

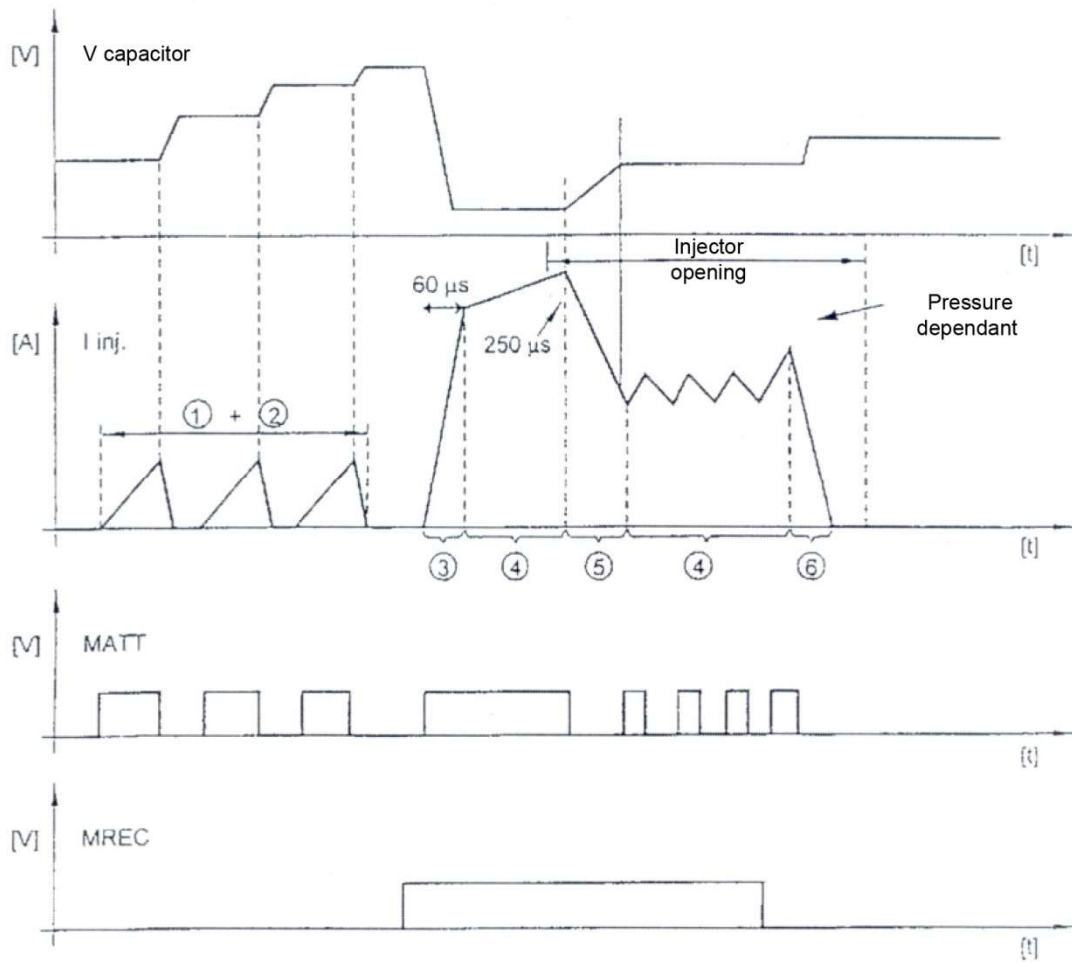
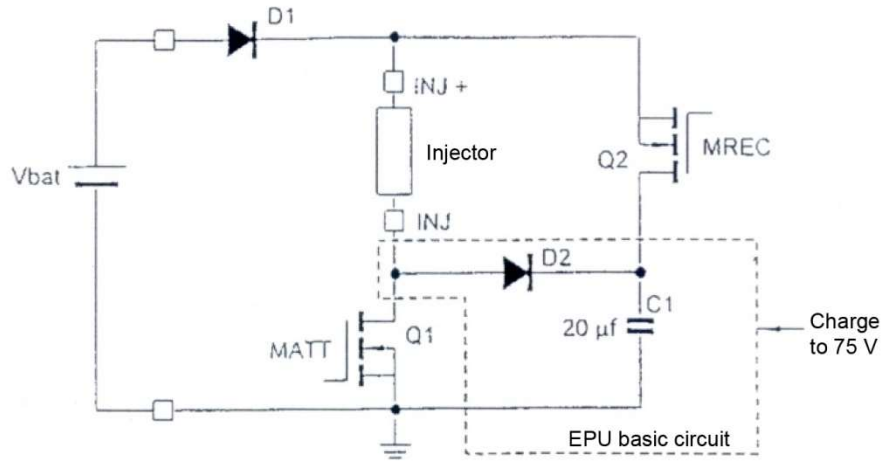

3.6. Measuring with the MT-H9000 model

1 With the MT-H9000 training bench, you will hear the noise of injectors and then hear the switch to idle at 3500 rpm.

The noise of the injectors will change at a certain speed.

What is this speed? ==> Approx. 3100 rpm.

What happens? ==> Below 3100 rpm, pre-injection occurs.

2 Fill out the following table using the MT-H9000 bench:

Speed	Load	mg/c	Approx. rail pressure in bar
3000 rpm	0	670	800
3000 rpm	¼	680	880
3000 rpm	½	690	1000
3000 rpm	¾	700	1230
3000 rpm	1	720	1260

Which component varies air flow at constant speed?: the *turbocompressor*.

9 At what speed will pre-injection stop?

10 Why does the injector winding not act directly on the needle?

11 Why can the 3rd piston of the pump be used for de-activation?

12 Which is the rest position of the pressure regulator for the 3-piston pump?

13 What residual pressure is left in the pump and how is this pressure created?

14 Which actuator does the high pressure sensor serve?



DECLARATION  OF CONFORMITY

By means of this declaration of conformity, as defined by the European Directive on Electromagnetic Conformity 2004/108/EC, the company:

S.A.S. ANNECY ELECTRONIQUE
Parc Altaïs – 1, rue Callisto
74650 CHAVANOD



Declares that the following product:

Brand	Model	Description
EXXOTEST	MT-H9000	TRAINING MODEL: Common Diesel Injection Rail

I - Has been manufactured in accordance with the requirements of the following European Directives:

- LV Directive 2006/95/EC - 12 December 2006
- Machinery Directive 98/37/EC - 22 June 1998
- EMC Directive 2004/108/EC - 15 December 2004

and satisfies the requirements of the following standard:

- NF EN 61326-1 dated 07/1997 +A1 of 10/1998 +A2 of 09/2001
Electrical measurement, control and laboratory equipment, EMC-related requirements.

II - Has been manufactured in accordance with the requirements of the European Directives relating to EEE design and WEEE management for the EU. :

- Directive 2002/96/EC dated 27 January 2003 on Waste Electronic and Electrical Equipment (WEEE)
- Directive 2002/95/EC dated 27 January 2003 on the limitations for the use of certain hazardous substances in the construction of Electronic and Electrical Equipment (EEE).

Drawn up in Saint-Jorioz on 24 July 2007.

CEO - Stéphane SORLIN

